



# THE AMERICANA







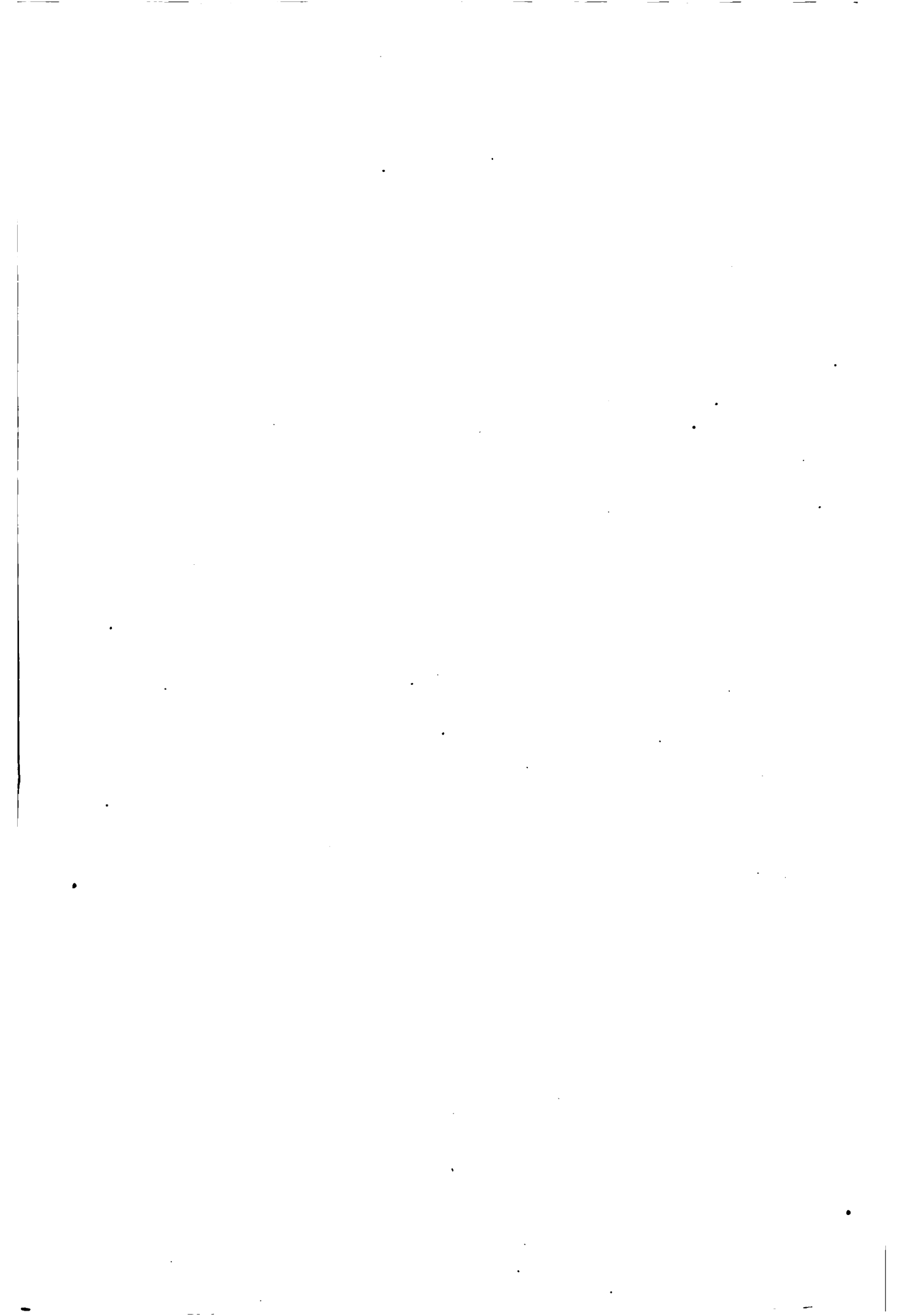









# THE ENCYCLOPEDIA AMERICANA

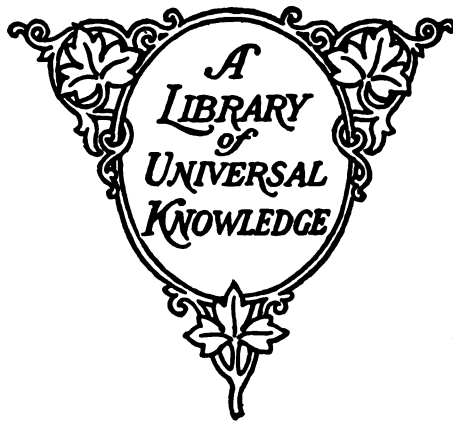

*IN THIRTY VOLUMES*

1918

THE ENCYCLOPEDIA AMERICANA  
CORPORATION

NEW YORK

CHICAGO

Cyc 364  
~~RF 2100.15~~



*J. J. Lowell fund*

COPYRIGHT, 1918

BY

THE ENCYCLOPEDIA AMERICANA CORPORATION

---

COMPOSITION, ELECTROTYPING, PRESSWORK, BINDING

BY

J. B. LYON COMPANY, ALBANY, NEW YORK

## PARTIAL LIST OF CONTRIBUTORS TO VOLUME X

- ALDEN, RAYMOND M., Ph.D., Litt.D.**  
Professor of English, Leland Stanford Junior University  
ESSAY
- BERRY, GEORGE R., Ph.D., D.D.**  
Professor of Old Testament Interpretation and Semitic Languages, Colgate University  
ESTHER, BOOK OF
- BOGART, ERNEST L., Ph.D.**  
Professor of Economics, University of Illinois  
FACTORY SYSTEM, THE
- BOTHNE, GISLE, A.B.**  
Professor of Scandinavian Languages and Literature, University of Minnesota  
ERASMUS MONTANUS
- BREWSTER, WILLIAM T., A.M.**  
Professor of English, Columbia University  
ENGLISH LITERATURE, VICTORIAN PERIOD—POETRY AND PROSE  
ESSAY ON MAN, THE
- BUCK, H. W., E.E., Ph.D.**  
Consulting Electrical Engineer, New York  
ELECTRICAL ENGINEERING
- BUELL, MARCUS D., S.T.B., D.D.**  
Professor of New Testament Greek and Exegesis, Boston University School of Theology  
EPHESIANS, EPISTLE TO THE
- BUTLER, AMOS W., A.M., LL.D.**  
Zoologist and Anthropologist, Indianapolis  
ETHNOLOGY
- CAIRNS, WILLIAM B., Ph.D.**  
Associate Professor of American Literature, University of Wisconsin  
ELSIE VENNER  
FALL OF THE HOUSE OF USHER
- CAJORI, FLORIAN, Ph.D., LL.D., Sc.D.**  
Professor of History of Mathematics, University of California  
EQUATIONS, GENERAL THEORY OF
- CANFIELD, ARTHUR G., Ph.D.**  
Professor of Romance Languages, University of Michigan  
ELLE ET LUI
- CHAMBERLAIN, CHARLES J., Ph.D.**  
Professor of Morphology and Cytology, University of Chicago  
EMBRYOLOGY OF PLANTS
- CHANDLER, FRANK W., Ph.D.**  
Professor of English and Comparative Literature, University of Cincinnati  
ELECTRA  
EXEMPLARY NOVELS
- CHEYNEY, A. R.**  
Philadelphia, Pa.  
ELECTRIC ALTERNATING CURRENT MACHINERY
- CHITTENDEN, FRANK H., Sc.D.**  
Entomologist, in Bureau of Entomology, United States Department of Agriculture, Washington, D. C.  
ENTOMOLOGY
- CHUBB, PERCIVAL**  
Leader of the Ethical Society of Saint Louis  
ETHICAL MOVEMENT AND ETHICAL SOCIETIES
- CLARK, L. PIERCE, M.D.**  
New York City  
EPILEPTIC CONSTITUTION
- COCHRANE, CHARLES H.**  
Author of "Modern Industrial Progress"  
ENGINE  
ENGINEERING TERMS
- COOPER, LANE, Ph.D.**  
Professor of English Language and Literature, Cornell University  
ENGLISH MAIL COACH, THE
- COUMBE, CLEMENT W.**  
Technical Art Expert  
ENAMELS AND ENAMELING  
ENGRAVINGS  
FAIENCE
- CREIGHTON, JAMES E., Ph.D., LL.D.**  
Professor of Logic and Metaphysics, Cornell University  
EMPIRICISM  
EPISTEMOLOGY
- DARTON, NELSON H.**  
Geologist, United States Geological Survey  
EXPLOSION CRATERS
- DEIMEL, RICHARD F., B.S., M.A.**  
Assistant Professor of Mechanics, Stevens Institute of Technology  
ELASTICITY
- DEWEY, JOHN, Ph.D., LL.D.**  
Professor of Philosophy, Columbia University  
ETHICS
- EGLIN, WM. C. L., E.E.**  
Second Vice-President and Chief Engineer The Philadelphia Electric Company  
ELECTRIC DIRECT CURRENT
- EISELEN, FREDERICK CARL, Ph.D., D.D.**  
Professor of Old Testament Interpretation, Garrett Biblical Institute  
EXODUS, BOOK OF

## Contributors to Volume X—Continued

**ERSKINE, JOHN, A.M.**

Adjunct Professor of English, Columbia University  
**ENGLISH LITERATURE, ELIZABETHAN PERIOD—NON-DRAMATIC POETRY**

**FARQUHAR, HENRY H.**

Consultant in Industrial Management and Instructor in the Harvard Business School  
**FACTORY MANAGEMENT**

**FERRIS, RICHARD, C. E., Sc.D.**

Editorial Staff of The Americans  
**ETHER**

**FORD, J. D. M., Ph.D.**

Smith Professor of French and Spanish Languages, Harvard University  
**EL SOMBRERO DE TRES PICOS  
 FABULAS OF TOMAS DE IRIARTE**

**FOWLER, HENRY THATCHER, Ph.D.**

Professor of Biblical Literature and History, Brown University  
**EZEKIEL, BOOK OF**

**GARNER, JAMES W., Ph.D.**

Professor of Political Science, University of Illinois  
**ENEMY ALIEN PROBLEMS**

**GAUSS, CHRISTIAN, Litt.D.**

Professor of Modern Languages, Princeton University  
**EMILE**

**GREENLAW, EDWIN, A.B., A.M., Ph.D.**

Kenan Professor of English in the University of North Carolina  
**FAERIE QUEENE, THE**

**HALE, EDWARD E., Ph.D.**

Professor of English, Union College, Schenectady, N. Y.  
**ENGLISH LITERATURE  
 ESSAYS OF BACON  
 FAIRY TALES OF HANS CHRISTIAN ANDERSEN**

**HALLER, WILLIAM, Ph.D.**

Instructor in English, Columbia University  
**ENOCH ARDEN**

**HAMLIN, ALFRED D. F., A.M., L.H.D.**

Professor of Architecture, Columbia University  
**EGYPTIAN ARCHITECTURE  
 ENGLISH ARCHITECTURE**

**HANFORD, JAMES H., Ph.D.**

Associate Professor of English, University of North Carolina  
**ESSAYS OF ELIA  
 EXCURSION, THE**

**HARRY, JOSEPH E., Ph.D.**

Author of "The Greek Tragic Poets."  
**EURIPIDES**

**HAYES, DOREMUS A., Ph.D., S.T.B.**

Professor of New Testament Exegesis, Garrett Biblical Institute, Evanston, Ill.  
**EXEGESIS**

**HIBBEN, JOHN GRIER, Ph.D., LL.D., L.H.D.**

President of Princeton University  
**EPICUREANISM**

**HOWARD, WILLIAM G., A.M.**

Assistant Professor of German, Harvard University  
**ELECTIVE AFFINITIES, THE**

**INGERSOLL, ERNEST**

Naturalist and Author  
**EYESIGHT IN THE LOWER ANIMALS**

**INGERSOLL, HELEN**

Naturalist  
**EVERGREENS**

**JACKSON, DUGALD C., C.E.**

Professor of Electrical Engineering, Massachusetts Institute of Technology  
**ELECTRICAL MEASURING INSTRUMENTS**

**KELLOGG, VERNON, A.B., M.S.**

Professor of Entomology, Leland Stanford Junior University, California  
**EVOLUTION  
 EVOLUTION, THEORIES OF**

**KENNELLY, A. E., Sc.D.**

Professor of Electrical Engineering, Harvard University  
**ELECTRICAL TERMS**

**KRAPP, GEORGE P., Ph.D.**

Professor of English, Columbia University  
**ENGLISH CHRONICLES**

**LAWRENCE, WILLIAM WITHERLE, Ph.D.**

Professor of English, Columbia University  
**ENGLISH LITERATURE, MIDDLE PERIOD**

**LINDQUIST, DAVID, E.E.**

Chief Engineer, Engineering Department, Otis Elevator Company.  
**ELEVATORS**

**MARTIN, THOMAS C., E.E.**

Secretary National Electric Light Association  
**ELECTRICAL MANUFACTURING INDUSTRY**

**MAVER, WILLIAM, Jr., C.E.**

Consulting Electrical Engineer  
**ELECTRIC MACHINE  
 ELECTRIC SIGNALING  
 ELECTRIC TRANSMISSION OF ENERGY  
 ELECTRIC UNDERGROUND CABLES AND CONDUITS  
 ELECTRICITY, ITS HISTORY AND PROGRESS**

**MCGREGOR, JAMES H., Ph.D.**

Professor of Zoology, Columbia University  
**EMBRYOLOGY  
 EMBRYOLOGY; HUMAN**

## Contributors to Volume X—Concluded

- MEADER, JOHN R.**,  
Editor and Author  
**EMPLOYMENT MANAGER**  
**EMPLOYMENT MANAGEMENT**
- MOSES, MONTROSE J., B.S.**  
Dramatic Critic  
**FAITH HEALER, THE**
- MUNROE, CHARLES E., S.B., Ph.D.**  
The George Washington University, Washington,  
D. C.  
**EXPLOSIVES**
- RISTEEN, ALLAN D., Ph.D.**  
Director Technical Research, The Travelers Insurance Company  
**ELECTRON THEORY**  
**ENERGETICS**
- PIERPONT, JAMES, Ph.D., LL.D.**  
Professor of Mathematics, Yale University  
**EQUATIONS, GALOIS' THEORY OF**
- RINES, IRVING E.**  
Editor of "History of the United States"  
**ELECTIONS**  
**ELECTORAL QUALIFICATIONS**  
**EXECUTIVE**
- ROUSH, G. A., A.B., M.S.**  
Assistant Secretary, American Electrochemical Society  
**ELECTROCHEMICAL EQUIVALENTS**  
**ELECTROCHEMICAL INDUSTRIES**  
**ELECTROCHEMISTRY**  
**ELECTROLYSIS**
- SAMUELS, BERNARD, M.D.**  
New York City  
**EYE, THE**
- SANBORN, F. B., A.B.**  
Author of a "Life of Emerson"  
**EMERSON, RALPH WALDO**
- SCHMIDT, NATHANIEL, A.M.**  
Professor of Semitic Languages and Literature,  
Cornell University  
**ENOCH, BOOK OF**  
**ESCHATOLOGY**
- SCHULMAN, A. G., B.A.**  
Department of Art, College City of New York  
**ETCHING: ITS TECHNIQUE AND**  
**GREAT MASTERS**
- SELLARS, ROY WOOD, Ph.D.**  
Professor of Philosophy, University of Michigan  
**EUCKEN, RUDOLF CHRISTOPH**
- SHERMAN, STUART P., Ph.D.**  
Professor of English, University of Illinois  
**EMPEDOCLES ON ETNA**  
**EOTHEN, ALEXANDER WILLIAM**  
**KINGLAKE**
- SINGLETON, ESTHER**  
Author of "French and English Furniture," "Art  
in Belgian Galleries," etc.  
**EMBROIDERY**
- SMITH, EDWARD WANTON, Ch.E.**  
Factory Engineer, The Electric Storage Battery  
Company, Philadelphia  
**ELECTRIC STORAGE BATTERY**
- SPINGARN, J. E., Ph.D.**  
Major, Infantry, U. S. A., formerly Professor of  
Comparative Literature, Columbia University  
**ENGLISH LITERATURE, ELIZA-**  
**BETHAN PERIOD—PROSE**
- STEINMETZ, CHARLES P., Ph.D.**  
General Electric Company, Schenectady, N. Y.  
**ELECTRICITY**
- TASSIN, ALGERNON, A.M.**  
Assistant Professor of English, Columbia University  
**ENGLISH LITERATURE, VICTORIAN**  
**PERIOD — DRAMA**
- TENNEY, ALVAN A., Ph.D.**  
Assistant Professor of Sociology, Columbia Univ.  
**EUGENICS**
- THOMSON, ELIHU, Ph.D., Sc.D.**  
General Electric Company, West Lynn, Mass.  
**ELECTRIC WELDING**
- THORNDIKE, A. H., Ph.D., L.H.D.**  
Professor of English, Columbia University  
**ENGLISH LITERATURE, ELIZA-**  
**BETHAN PERIOD—THE DRAMA**
- TOUSEY, SINCLAIR, M.D.**  
New York City  
**ELECTROTHERAPEUTICS**
- TRENT, WILLIAM P., LL.D., D.C.L.**  
Professor of English Literature, Columbia Univ.  
**ELEGY WRITTEN IN A COUNTRY**  
**CHURCHYARD**
- TUCKER, MARION, Ph.D.,**  
Professor of English, The Polytechnic Institute of  
Brooklyn  
**EPISTLE TO ARBUTHNOT**  
**EPISTLE TO AUGUSTUS**  
**FABLE FOR CRITICS, A**
- UNDERHILL, JOHN GARRETT, Ph.D.**  
Representative of the Sociedad de Autores Espanoles  
in the United States and Canada  
**EL GRAN GALEOTO**  
**ELECTRA**
- VAN DOREN, CARL, Ph.D.**  
Associate Professor of English, Columbia University  
**EVANGELINE**
- VEAZIE, WALTER B., Ph.D.**  
Department of Philosophy, Columbia University  
**ESSAY ON THE HUMAN UNDER-**  
**STANDING, AN**
- WALSH, JAMES J., Ph.D., M.D., Litt.D., Sc.D.**  
Author of "The Thirteenth the Greatest of Cen-  
turies"  
**EIGHTEENTH CENTURY**  
**EIGHTH CENTURY**  
**ELEVENTH CENTURY**
- WILCZYNSKI, ERNEST J., Ph.D.**  
Professor of Mathematics, University of Chicago  
**EQUATIONS**

## KEY TO PRONUNCIATION.

---

<p>ā far, father</p> <p>ā fate, hate</p> <p>a or ā at, fat</p> <p>ā air, care</p> <p>ā ado, sofa</p> <p>ā all, fall</p> <p>ch choose, church</p> <p>ē eel, we</p> <p>e or ě bed, end</p> <p>é her, over; also Fr. <i>e</i>, as in <i>de</i>; <i>eu</i>, as in <i>neuf</i>; and <i>oeu</i>, as in <i>boeuf</i>, <i>coeur</i>; Ger. <i>ō</i> (or <i>oe</i>), as in <i>ökonomie</i>.</p> <p>ę befall, elope</p> <p>ē agent, trident</p> <p>ff off, trough</p> <p>g gas, get</p> <p>gw anguish, guava</p> <p>h hat, hot</p> <p>h or H Ger. <i>ch</i>, as in <i>nicht</i>, <i>wacht</i></p> <p>hw what</p> <p>ī file, ice</p> <p>i or ĭ him, it</p> <p>ı between e and i, mostly in Oriental final syllables, as, Ferid-ud-din</p> <p>j gem, genius</p> <p>kw quaint, quite</p> <p>ñ Fr. nasal <i>m</i> or <i>n</i>, as in <i>embon-point</i>, <i>Jean</i>, <i>temps</i></p>	<p>ñ Span. <i>ñ</i>, as in <i>cañon</i> (căn'yôn) <i>piñon</i> (pên'yôn)</p> <p>ng mingle, singing</p> <p>nk bank, ink</p> <p>ō no, open</p> <p>o or ǒ not, on</p> <p>ô corn, nor</p> <p>ò atom, symbol</p> <p>ọ book, look</p> <p>oi oil, soil; also Ger. <i>eu</i>, as in <i>beutel</i></p> <p>ö or oo fool, rule</p> <p>ou or ow allow, bowsprit</p> <p>s satisfy, sauce</p> <p>sh show, sure</p> <p>th thick, thin</p> <p>th father, thither</p> <p>û mute, usc</p> <p>u or ũ but, us</p> <p>ú pull, put</p> <p>ü between u and e, as in Fr. <i>sur</i>, Ger. <i>Müller</i></p> <p>v of, very</p> <p>y (consonantal) yes, young</p> <p>z pleasant, rose</p> <p>zh azure, pleasure</p> <p>'(prime), "(secondary) accents, to indicate syllabic stress</p>
---	--



**E** GUSQUIZA, Juan Bautista, hoo-än' bā-tēs'tā ā-goos-ké'thā, Paraguayan statesman: b. Asunción, 1845. He was a lieutenant-colonel in the war with Uruguay, Brazil and the Argentine Republic, later being appointed Secretary of War and attaining the rank of general. He was president of Paraguay from 1894 to 1896.

**EGYPT.** (Greek, *Αἴγυπτος*, *Aiguptos*; Hebrew, *מצרים*, *Misraim* or *מצור*, *Mazor*; also called *פתיח*, *Pathros* (Is. xi, 11) and *אֶרֶץ חַמ*, *Eres-Ham*, "The land of Ham" (Ps. cvi, 22). Assyrian *𐎶𐎵𐎠𐎺*, *Musri*; Arabic *مصر*, *Misr* or *Masr*. In Hieroglyphics, *ꜥꜣ*, *Kamt*). Its present name is derived from the Greek, *Aiguptos* (meaning obscure). The Hebrew name *Misraim*, is the dual form of *Mazor* (a fortified or walled-in place or country), viz., two *Mazors*, "Upper and Lower Egypt." But its principal name upon the monuments and in the papyri is *Kami* or *Kamt* "Black land", an appropriate name, owing to the black alluvial soil in the Nile Valley, in contradistinction to the reddish soil of the neighboring land on both sides of the Nile.

Modern Egypt is a vast country extending from the Mediterranean Sea, lat. 31° 35' to parallel 22° N. l., called Egypt Proper, thence southward to the British possessions in equatorial Africa, which latter region (known as the Egyptian Soudan) is jointly governed by Great Britain and Egypt. The eastern boundary is the Red Sea, and on the extreme northeast, Wady-el-Arish, Syria. The western boundary runs northwest to Tripoli, and thence southeast through the Libyan desert, to a point 200 miles west of Wady-Halfa. The area of Egypt (exclusive of the Soudan) is about 363,181 square miles, the country extending 675 miles north and south, and 500 miles east and west.

**Topography.**—In modern as in ancient times Egypt was always divided into the Upper and the Lower, or the Southern and Northern countries. At a very early period it was further subdivided into a number of departments, called *nomes*, varying in different ages; 42 was probably the usual number. A third great division, the *Heptanomis*, "seven *nomes*," preserved in the modern (*Wustani*) "Middle Egypt," was introduced at the time of the geographer Ptolemy (first half of the 2d century A.D.). Each *nome* had a separate local government. In the 5th century A.D., Egypt was divided into six eparchies. Augusta Prima

and Secunda on the east, *Egyptiaca* on the west, Arcadia (the former Heptanomis), Thebais Proxima as far as Panapolis, and Thebais Supra to Philæ. Under the Mohammedans, the triple division, *Misr-el-Bahri* (Lower Egypt); *el-Wustani* (Middle); and *es-Said* (Upper) has prevailed, but the number of subdivisions has varied. At present there are altogether five governments of principal towns, and 14 provinces subdivided into districts.

Egypt is connected with Asia by the Isthmus of Suez, across which runs the great canal, about 100 miles long. The inhabited portion of Egypt is mainly confined to the valley and delta of the Nile, the widest part of which does not exceed 120 miles, while in many parts of the valley it is only from 3 to 15 miles wide, and at the southern frontier of Egypt proper, only two miles. West of the Nile are several oases. Two ranges of lofty mountains, the Arabian Hills on the east and the Libyan on the west, enclose this valley. The delta of the Nile is traversed by a network of primary and secondary channels and is also intersected by numerous canals.

Seven principal channels or mouths were usually recognized in ancient times, the names of which, going from east to west, were the Pelusiatic mouth, the Tanitic, the Mendesian, the Pathmitic, the Sebennytic, the Bolbitine and the Canopic. Now only the Bolbitine (called Rosetta) and the Pathmitic (Damietta), are in existence. The Nile has a current running seaward at the rate of 2½ or 3 miles an hour and the stream is always deep enough for navigation. The water becomes a reddish-brown during the annual overflow; it is esteemed highly salubrious. Near the sea are the lakes Menzaleh, Birket-el-Mariut and other extensive but shallow lagoons.

The openings or lateral valleys of the hills confining the valley of the Nile are comparatively few, or, being little frequented, are not well known. Those on the east side with which we are best acquainted are the Wady-el Tili, "Valley of the Wanderings" (of the children of Israel), leading from the neighborhood of Cairo to the head of the Gulf of Suez, and that through which passes the road from Koptos to Kosseir on the Red Sea. A short distance west of the Nile and above the Delta is the fertile valley of Fayum, in the northwest and lowest part of which is the Birket-el-Kerun Lake, fed by a canal or branch from the Nile. The level of the lake is now 130 feet below that of the

Mediterranean. This lake, formerly known as Lake Moeris, covered a far larger area, and by means of sluices and other works was utilized for irrigation purposes. The deserts on the west bank of the Nile generally present to view plains of gravel or of fine drifting sand; on the east, the scene is varied by rocks and mountains.

**Climate.**—The atmosphere in Egypt is extremely clear and dry, the temperature regular and hot, though the heat is tempered during the daytime for seven or eight months of the year by the strong wind which blows from the north and which enables sailing vessels to ascend the river against the stream. The winter months are the most delightful of the year, the air being cool and balmy and the ground covered with verdure; later, the ground becomes parched and dry, and in spring the suffocating *khamseen*, or simoom, frequently blows into the Nile valley from the desert plains on each side of it, raising lofty clouds of fine sand and causing great annoyance, until the rising of the river again comes to bless the land. It rains but rarely, except near the seashore. At Memphis the rain falls perhaps three or four times in the course of a year, and in Upper Egypt only once or twice, if at all; showers of hail sometimes reach the borders of Egypt, but the formation of ice is very uncommon. Earthquakes are occasionally felt and thunder and lightning are neither frequent nor violent. Egypt is not remarkably healthy, especially in the delta, where ophthalmia, diarrhoea, dysentery and boils are somewhat prevalent. But many invalids now winter in Egypt, especially in the neighborhood of Cairo, or higher up the river, where the air is dry and pure.

**The Nile, Irrigation and Agriculture.**—The great historic river Nile, Greek Neilos; Latin Nilus; Hebrew Yeor or Shihor; Arabic En-Neel (black), is 3,400 miles in length, the longest in Africa and one of the great rivers of the world. It divides at lat. 30° 15', just below Cairo, into two main streams, the one entering the sea by the Rosetta mouth on the west, the other by the Damietta mouth on the east. These two streams carry the bulk of the Nile water to the Mediterranean and enclose a large portion of the territory known as the delta, from its resemblance to the Greek letter Δ and which owes its existence to the deposits of alluvial matter brought down by the stream. The most remarkable phenomenon connected with the Nile is its annual regular increase, arising from the periodical rains which fall within the equatorial regions and the Abyssinian Mountains. As rain rarely falls in Egypt, the prosperity of the country entirely depends on this overflowing of the river. On the subsiding of the water the land is found to be covered with a brown slimy deposit, which so enriches the soil that with a sufficient inundation, it produces two crops a year, while beyond the limits of the inundation there is no cultivation. The Nile begins to rise about the middle of June and continues to increase until about the end of September, overflowing the lowlands along its course, the water being conveyed to the fields by artificial courses where natural channels fail. After remaining stationary for a short time, the river rises again but subsequently begins to subside, showing a markedly lower level in

January, February and March and reaching its lowest in April, May and early June. The overflow water is now to a great extent managed artificially by means of an extensive system of reservoirs and canals, so that after the river subsides it may be used as required. A certain proportion of the fields, after receiving the overflow and being sown, can ripen the crop without further moisture; but many others always require artificial irrigation. Steam pumps are now largely used in northern Egypt. Latterly the government has tried to make the farmers less and less directly dependent on the inundation, and the great barrage of the Nile below Cairo, the largest weir in the world, is one means to this end, the great dam or barrage at Assouan being another.

The native methods of raising water for irrigation are chiefly by the *sakieh*, or water wheel, and the *shádouf*. The first consists of a horizontal wheel turned by one or two oxen, which sets in motion a vertical wheel, around which are hung a number of earthen jars, this wheel being sunk into a reservoir connected with the river. The jars thus scoop up the water and bring it to a trough on a level with the top. Into this trough each jar empties itself in succession and the water is conducted by an inclined channel into the cultivated ground adjoining, which may have been previously divided into compartments of 1 or 2 yards square by raising the mold into walls or ridges of 5 or 6 inches in height. Into these compartments the cultivator forms an entrance for the water by depressing a little space in the ridge or wall with the sole of his foot; and this overlooking of the channels of irrigation and adjustment of the openings from one compartment to the other with the foot is continued till the cultivator is assured by the growth of the plants that each compartment is daily and duly supplied with its proper quantity of water. The second means of raising water, namely, the *shádouf*, consists of a leather bucket slung at one end of a pole which has a weight at the other and sways up and down on a vertical support, a contrivance by which the cultivator is enabled to scoop up the water considerably below his feet and raise it with comparative ease to the mouth of a channel on a level with his breast. The latter mode of raising water is of great antiquity and is depicted on the walls of the ancient tombs of Egypt and also in the sculptures of Nineveh. A sufficient rise of the river (the rise varies at different points) is essential to secure the prosperity of the country; and as the water subsides, the chaplet of buckets on the *sakieh* is lengthened, or several *shádoufs*, rising one above the other on the river bank, are required. Should the Nile rise above the requisite height it may do great damage; on the other hand if it should not attain the ordinary height, there is a deficiency of crops; but with rare exceptions, the inundations are regular and nearly uniform. See DELTA; IRRIGATION.

**The Nile Barrage.**—One of the greatest wonders of modern times, rivaling the Pyramids of the ancients, is the Nile Barrage. Thanks to Lord Cromer and Lord Kitchener, the stupendous work at Assouan and Assiut of taming the Nile, is an accomplished fact. Egypt is no more subject to the caprices of the Nile. The precious fertilizing fluid coming down from



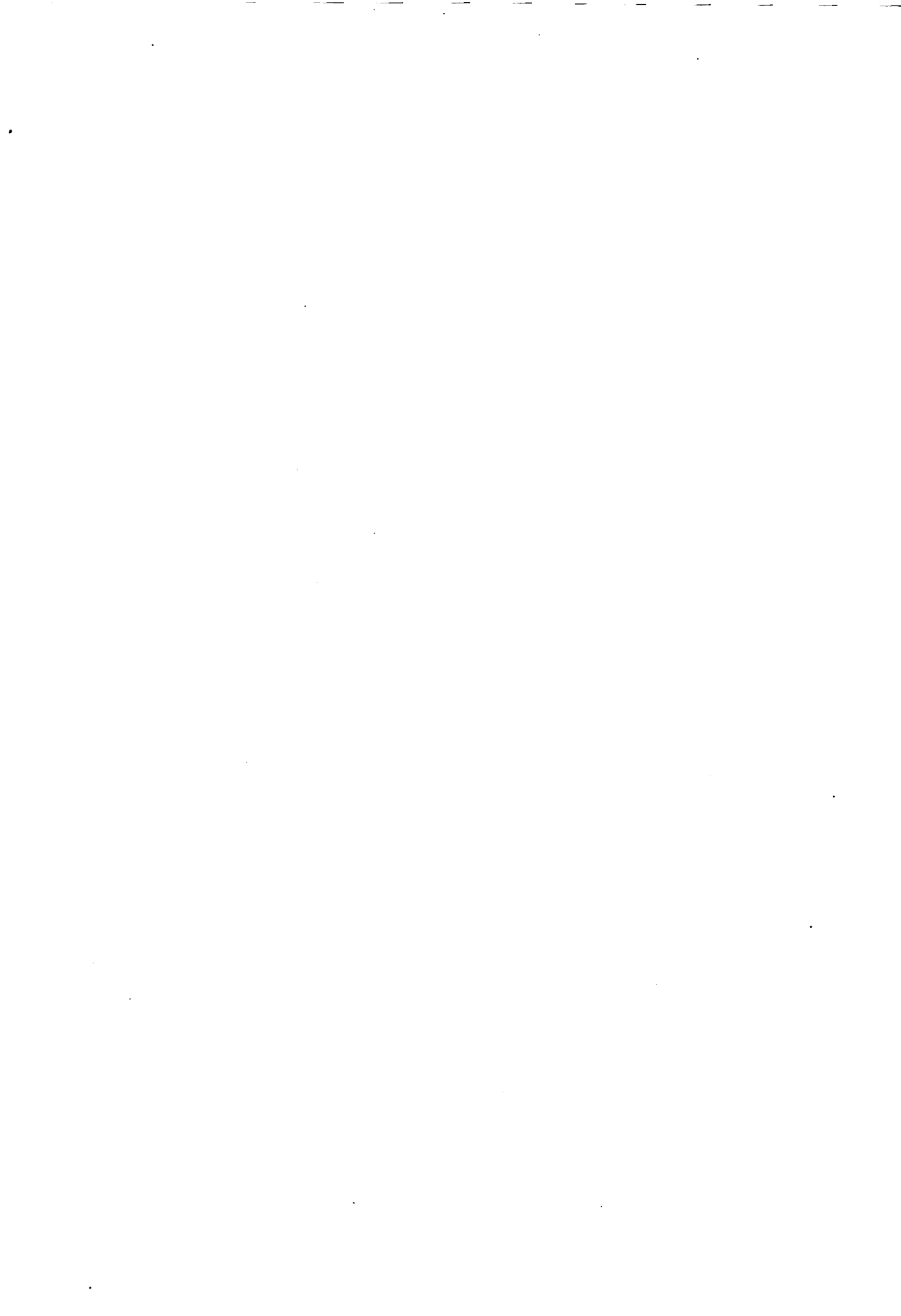



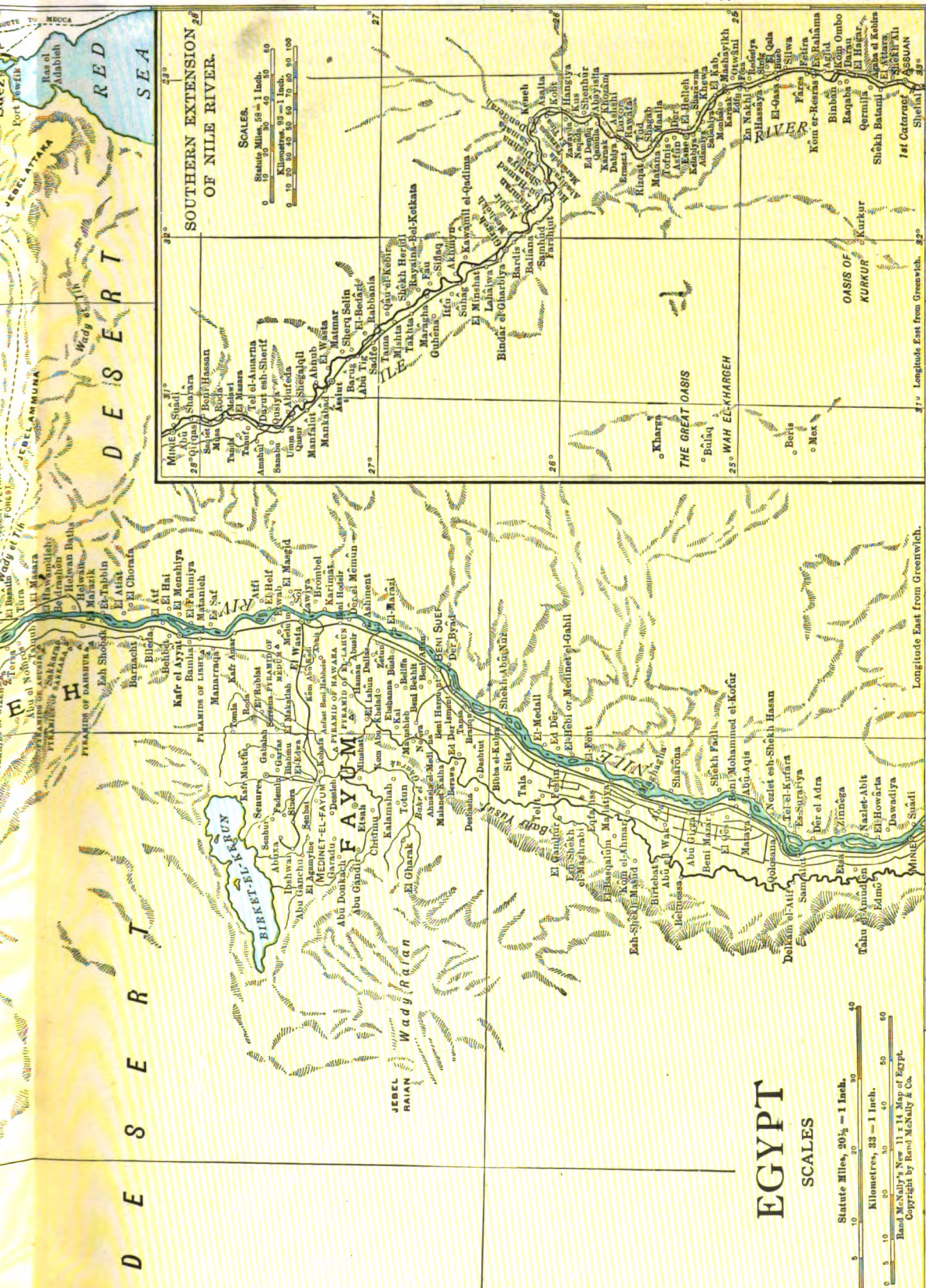

# EGYPT

STATUTE MILES, 30% = 1 INCH.  
 KILOMETRES, 33 = 1 INCH.  
 RAND McNALLY'S NEW 11 x 14 MAP OF EGYPT.  
 Copyright by Rand McNally & Co.

**SOUTHERN EXTENSION OF NILE RIVER.**

**SCALES.**  
 Statute Miles, 30 = 1 inch.  
 Kilometres, 33 = 1 inch.

**DESERT**

**THE GREAT OASIS**

**Wah El-Kharjah**

**OASIS OF KURKUR**

Longitude East from Greenwich, 30°

Longitude East from Greenwich, 31°

Longitude East from Greenwich, 32°

Longitude East from Greenwich, 33°

Latitude North, 25°

Latitude North, 26°

Latitude North, 27°

Latitude North, 28°

Latitude North, 29°

6

7

8

9

10

11

A

B

C

D

E

F

G

H

I

RED SEA

JEBEL ATAKA

JEBEL RAHAN

Wady el-Nil

Wady el-Kharjah

Siwa

Bahariya

Farafra

Dakhla

Kharga

Cairo

Alexandria

Luxor

Assuan

Assiut

Port Said

Suez

Ismaïlia

Malak

Wady el-Nil

Wady el-Kharjah

Wady el-Bahariya

Wady el-Farafra

Wady el-Dakhla

Wady el-Kharga

Siwa

Bahariya

Farafra

Dakhla

Kharga

Cairo

Alexandria

Luxor

Assuan

Assiut

Port Said

Suez

Ismaïlia

Malak

Wady el-Nil

Wady el-Kharjah

Wady el-Bahariya

Wady el-Farafra

Wady el-Dakhla

Wady el-Kharga

Siwa

Bahariya

Farafra

Dakhla

Kharga

Cairo

Alexandria

Luxor

Assuan

Assiut

Port Said

Suez

Ismaïlia

Malak

Wady el-Nil

Wady el-Kharjah

Wady el-Bahariya

Wady el-Farafra

Wady el-Dakhla

Wady el-Kharga

Siwa

Bahariya

Farafra

Dakhla

Kharga

Cairo

Alexandria

Luxor

Assuan

Assiut

Port Said

Suez

Ismaïlia

Malak

W  
a  
K  
S  
b  
n  
x  
r  
b  
u  
E  
f  
r

equatorial Africa by way of Bahr-el-Ghazal and Bahr-el-Abyad are halted and stored in an immense reservoir 200 miles long, with, since 1912, a holding capacity of 9,000,000 cubic feet. By the giving of perpetual irrigation two or three crops may be raised annually, and the productivity of the soil is increased by 50 per cent. Millions of acres on both sides of the river have been reclaimed. Other works have been constructed within the past 10 years, showing equally marvelous results. Egypt's prosperity always depended upon the Nile. The "seven year famine" recorded in Scripture was the result of insufficient irrigation, and there is an earlier instance of a similar character recorded in hieroglyphics on the rocks of Assouan. After many centuries of inertness and decay Egypt lifts up her head and promises to become again the storehouse of the East.

**Oases.**—The fertile spots peculiar to the deserts of Africa are found in Egypt along the hollow region of the Libyan Desert, parallel to the general direction of the valley of the Nile, and above 80 miles west of it. The Great Oasis or Wah-el-Khargeh, lies immediately west of the Thebaid, and has a length of 100 miles. About 50 miles west of the northern extremity of this oasis lies the Wah-el-Dakhileh 24 miles long and 10 miles broad. West by south from the Fayum the date groves of the Little Oasis, or Wah-el-Baharieh, display their unusual verdure. In this fertile spot artesian wells are numerous and some of ancient construction have been discovered which have a depth exceeding 400 feet. On the road between this oasis and that of El Dakhileh, inclining to the west, occurs half way the Wah-el-Farāfrah of small extent. West of the Fayum and about 200 miles from the Nile, lies the oasis of Siwah. The inhabitants of this secluded spot, though tributary to Egypt, are in language and manners wholly Libyan. The region of the oases terminates toward the north in the desert of the Natron lakes. See OASIS.

**Fauna.**—Owing to the absence of forests in Egypt there are few wild animals, the principal species being the fox, jackal, hyena, the wild ass, the ibex in the Red Sea hills and several kinds of antelope. The chief domestic animals are camels, horses, asses, horned cattle and sheep. The hippopotamus is no longer found in Egypt, though it is met with in the Nile above the cataracts and the crocodile is found in Upper Egypt. Among the birds are three species of vultures (one of which is very large, individuals sometimes measuring eight feet across the wings), eagles, falcons, hawks, buzzards, kites, crows, linnets, larks, sparrows and the beautiful hoopoe, which is regarded with superstitious reverence. Pigeons, quail and various kinds of poultry are very abundant and numerous aquatic birds and pelicans. The ostrich is found in the deserts. Among the reptiles are the horned viper (*cerastes*) and the asp (*naja haja*), both poisonous. Fishes abound in the Nile and lakes and furnish a favorite article of food. Waterfowl are plentiful and were anciently prepared and salted like fish. The sacred ibis is still a regular visitor during the inundation and the pelican is found in the northern lagoons. Among the countless insects are the sacred beetle (*Ateuchus sacer*) and the migratory locust.

**Flora.**—The few trees found in Egypt include the date-palm, tamarisk, sycamore, Christ's-

thorn, carob and two species of acacia. Many trees have been planted in recent times, especially about Cairo, such as the lebbek (*Albizzia Lebbek*) and the eucalyptus. The papyrus plant, once so important, is now to be found only in one or two spots. A paper was manufactured from it, which was supplied to all the ancient world. Boats, baskets, cords and shoes were also made from it. Wine was abundantly produced in ancient Egypt and the sculptures bear ample testimony to the extent to which the ancient Egyptians indulged in wine and beer or other intoxicating beverages. The vine is still much cultivated, but little or no wine is made, as it can easily be imported. The following plants are sown immediately after the inundation begins to subside and are harvested three or four months later: wheat, barley, beans, peas, lentils, vetches, lupins, clover, flax, lettuce, hemp, coriander, poppies, tobacco, watermelons and cucumbers. The following plants are raised in summer chiefly by means of artificial irrigation: durra, maize, onions, henna, sugar-cane, cotton, coffee, indigo and madder. Several varieties of dates and grapes are the most common, but other fruits such as figs, pomegranates, apricots, peaches, oranges, lemons, citrons, bananas, mulberries and olives are plentiful. The lotus or water-lily is the chief species of flower found in Egypt. There is a high coarse grass called *halfa* and various kinds of reed and canes.

**Geology and Mineralogy.**—Granite, eocene limestone and sandstone are the principal rock formations found in Egypt. But in the Nile Valley from 25° North Latitude to the Fayum, sandstone predominates. At Syene, the southern extremity of Egypt proper, granite predominates. Its quarries have supplied the materials for the obelisks and many colossal statues of Ancient Egypt. A great extent of the country is covered with moving sands; the soil bordering the Nile, owing to the encroachment of the shifting sands of the desert, consists of an argillaceous earth or loam, more or less mixed with sand. This sedimentary deposit shows no trace of stratification. In addition to those already mentioned, there are various other minerals, which were employed in architecture, sculpture, etc. These include syenite, basalt, alabaster, breccia and porphyry. Among other valuable products of Ancient Egypt were emeralds, gold from the mines in Upper Egypt, iron from the desert plains of Nubia and natron from the lakes in the Oasis of Ammon (hence named Ammonia, Latin *sal-ammoniacum*). Bitumen, salt and sulphur are also among the minerals of Egypt.

**Government.**—Egypt in modern times has been held as a suzerain of Turkey under the rule of a Khedive. In 1879 it came under the joint control of Great Britain and France as security for the European bondholders. During the rebellion organized by Arabi Pasha in 1882 France refused to intervene and after his defeat and the restoration of the Khedive's authority the dual control came to an end and the government of the country was effectively controlled by the British authorities, but still under Turkish suzerainty. Since the beginning of the British occupation great reforms have been carried through in every department of the public service; the finances have been placed on a sound basis; extensive public works have been carried through; the

Sudan (q.v.) has been reconquered and the fear of incursions from the south brought to an end.

In 1883 an organic law was promulgated by the Khedive creating a number of representative institutions whose functions were almost wholly consultative. In July 1913 this law was repealed by an act bringing into operation a legislative assembly consisting of 85 members, 66 of whom are elective and in which the ministers sit. Provincial councils have been organized with powers of regulation over markets, local administration and elementary vernacular education and trade schools.

**Justice.**—The administration of Egyptian justice is extremely complicated. There are four classes of courts: (1) The *mehkemehs*, or Mohammedan courts, conducted according to the precepts of the Koran and the principles of the Mohammedan religion, and retaining jurisdiction in matters of personal law only. (2) The so-called native tribunals, composed of 90 summary tribunals, 8 central tribunals and a court of appeals at Cairo. These deal with crimes committed by natives and civil actions between natives. The most recent addition in this category has been the creation of village or cantonal courts, having powers analogous to those possessed by English justice of peace courts. (3) The consular courts, which deal with civil cases between foreigners of the same nationality and also try criminal cases in which the accused are foreigners not within the jurisdiction of the mixed tribunals. (4) The mixed tribunals, dating from 1876, which have jurisdiction in all matters civil and commercial between natives and foreigners or between foreigners of different nationalities. These courts are admittedly successful. A code of laws has been published for the greater systemization of native jurisprudence.

**Education.**—The chief seat of Koranic education is the famous University of El Azhar, founded by Saladin about 1170 and still employing the same methods of instruction that were originally in use. The faculty numbered in 1918 about 300 moulahs or priests, many having wide reputation for scholarship; the students, some 10,000, are from India, Turkey, Syria, Afghanistan and other Mohammedan countries. There is no regular university organization nor arrangement for the endowment of departments or founding of chairs. Anyone who can collect a class is allowed to lecture. Frequently the professors practise law, hold clerkships or are connected with mosques in Cairo. There is no charge for instruction. Three-fourths of the students study theology, though other "ologies" and geography, philosophy and astronomy are also taught. There are also in Cairo eight colleges and professional schools of excellent grade. The Egyptian Ministry of Public Instruction has under its direction schools for engineering, medicine, law and agriculture, technical schools and normal training schools for teachers. A military school is under the management of the war office. The number of indigenous schools under control of the provincial councils on 31 Dec. 1915 was 3,666, with a total enrolment of 250,575 (225,073 boys). Higher educational institutions under the board of education have an enrolment of 26,662 (20,507 boys, 6,115 girls). Of native Egyptians, according to the census of 1907, 85

per 1,000 males were able to read and write and three per 1,000 females.

**Technical Training.**—In 1907 the authorities introduced a new system of technical education in Egypt under the direction of Mr. Sidney Wells, which has made remarkable progress despite peculiar difficulties in a country where a technical or an industrial career carried with it a social stigma. It was divided into three branches—industrial, agricultural, commercial. In the first two branches, obviously the most important three sections have been organized, corresponding with the social grades of the people and the needs of the various classes of either branches. In the general educational scheme are the *Kittabs* or village schools, the primary and the secondary schools. The new plan provides for manual workmen, foremen and managers and skilled professional workers. Under industrial education are comprised trade schools, a technical school and a school of engineering; under agricultural are included farm schools, intermediate schools and a school for agriculture. The trade schools—some called model workshops—provide a system of apprenticeship in trades that are in demand and of local interest; the apprentices, all of the poorer classes and from the age of 12 and with but a very rudimentary knowledge, are taught a four years' course in carpentry, furniture-making, plumbing, shoemaking, tailoring, saddlery, etc. They accept outside work, and in 1914 17 such workshops executed orders valued at \$150,000. The 11 farm schools afford practical training in elementary agricultural matters to the poorer class.

Demanding primary certificates the Boulaq technical and the intermediate agricultural schools deal with the middle classes. The first has three sections in a four-year course—mechanical and electrical engineering, building trades and scavenging, artistic crafts. The second, in a three-year course, creates in the first case draftsmen, architects, assistant engineers, builders, clerks and lecturers on technical topics; and also to improve the knowledge of landed proprietors and to train pupils to fill managers' positions. The highest schools—those of engineering and agriculture—form, with the schools of medicine and law, the nucleus for the future university. The course is four years and conditioned on the secondary certificate. Irrigation, engineering and architecture, with very advanced agricultural education, are taught. Graduates are fitted to fill vacancies in the ministries of public works and agriculture, to become expert lecturers and occupy higher technical posts outside government service. Besides mere instruction the department encourages local industries and introduces modern methods in carpet making or weaving and will provide new industries after the present war. A specialty has been made in Upper Egypt of the manufacture out of natural colored wools of carpets of much beauty and unique design.

Commercial education, the third branch of technical training, is more recent. Evening classes for shorthand and then in typewriting, commercial arithmetic and bookkeeping (in English, French and Arabic) were established in Cairo, Alexandria and Mansura. ~~Less than two~~

schools of commerce were opened, to include specializing in accountancy, secretarial work and general commerce. The authorities, too, co-operate with the training of girls at the Cairo Trade School where dressmaking, embroidery and stocking-making are taught, the articles being sold at an adjacent shop. Further five economic schools are operated. In the 51 schools imparting various kinds of instruction are over 5,500 pupils; nine years ago there were 1,029 pupils in eight such schools. Efforts will be made not to neglect the many native industries in the encouragement of certain European trades. Consult *London Times Educational Supplement*, 7 Sept. 1915.

**Religion.**—At the present day about 91.84 per cent of the people in Egypt profess the Sunnite (Mohammedan) faith, and 7.81 per cent Christian. The Armenians also have a church and a bishop at Alexandria and Cairo. There is an American mission in both cities, but the natives are conservative and not inclined toward religious beliefs other than their own.

**Commerce and Industry.**—To-day the one branch of industry for which Egypt is peculiarly adapted by nature is agriculture and large quantities of cereals, cotton and other agricultural produce are raised; yet, generally speaking, agriculture is still in a very low state, the necessary consequence of the wretched condition and extreme poverty of those engaged in it. The Egyptians still adhere to their ancient custom of uniting the followers of each business or profession into a guild, governed by their sheikh, who acts, if need be, as their representative. These guilds are exceedingly numerous, as might be expected among a people whose social organization dates from a remote antiquity.

Among the crops which the Egyptians grow with success, cotton is the most popular and profitable. (See **COTTON**). The cotton plant of Egypt differs materially, in one respect at least, from that of other countries. In America it has been found unprofitable to allow the plants to continue in the ground longer than one year. In Egypt, however, the case is different, for the cotton plant yields five, and sometimes six, consecutive crops before replanting is found to be necessary. This being the case, a cotton field once planted is a secure investment for at least five years, and as peasants of the Nile do not love labor, more cotton is grown in Egypt in proportion to the population engaged in agriculture than in any other part of the world. In both Upper and Lower Egypt cotton is therefore the standard crop, and as it is not troubled with worms as in America, and by the method of irrigation the farmer can give it exactly the right portion of moisture and no more, the crop is tolerably reliable. Boats transport the product to Cairo or to Alexandria, the leading cotton markets. The exchange in the former city is located on one of the principal streets, while the market proper is in a public square opposite the great mosque of Hassan. The time of the river journey to Alexandria is from six days to six months, but, as the Mohammedans say, "God is great, and there is no hurry."

The business of tanning is also one of the industries in which the Egyptians perfectly succeed, by a process peculiar to themselves. They make excellent morocco leather, which is goat-skin dressed and dyed in a particular manner.

The pottery of Egypt also deserves a word of praise, chiefly for the merit of the bardaks or water-jars. Coarse cotton cloths, and cloths of mixed cotton and wool, are largely made in the country; silk is cultivated to some extent; and the cultivation of the sugar-cane received a great impulse from the viceroy, Ismail, who, at a great expense, erected a number of mills. Goods carried by the Suez Canal do not form part of the commerce of the country, and the transit trade proper is of little importance. In 1915, 4,590 steamers of registered tonnage of 12,353,573 cleared at Egyptian ports and 1,465 sailing vessels (foreign and coastal) of 85,726 tons. The produce of cotton had increased from 5,001,000 kantars (1 kantar=99.05 lbs.) in 1909-10 to 6,878,000 kantars in 1914-15. In 1915 the area sown and yield of wheat were 1,592,085 acres and 1,060,000 tons; barley 462,577 acres and 300,000 tons; maize and millet, 2,194,031 acres; rice, 330,923 acres. In the same year the sugar exports amounted to 26,257 tons, valued at \$2,868,075, and of the cotton exports to 6,899,122 kantars valued at \$95,728,220. The imports for 1915 were valued at \$96,644,965 (of which Great Britain sent \$43,692,990) and exports at \$135,234,360 (of which Great Britain took \$69,678,125).

**Finances.**—The unfortunate financial situation under the former khedives, becoming bankrupt in the time of Ismail Pasha, was in reality a blessing in disguise for the laboring classes, since it led to the reform of conditions which had become well-nigh intolerable. The taxes were exacted with brutal rigor, even torture being resorted to in their collection and they were moreover excessive. The principal taxes were the *Kharagh* or territorial tax, *Werka* or income tax and *Himi* or tax on commerce. From the start the property of the khedive and his higher officials were exempted. The English régime has lowered the imposts by over £2,000,000 (\$10,000,000) annually and has abolished altogether the hated tax on salt, also the bridge and port tolls on the Nile and those collected from trading barks and fishing vessels. The registration tax on land sales has been reduced from 5 to 2 per cent, also those on water transport, and the customs duties on coal, combustible liquids, building wood, petroleum, meat and foodstuffs. The inland fisheries have been relieved of the vexatious restrictions under which they formerly labored. The postal, telegraph and railway rates have also undergone a material reduction. Thus it may be said that at present the Egyptians, especially those dwelling in the cities and towns, are unburdened by imposts of any kind. Up to 1888 the finances of the country were piling up a yearly deficit. This condition has been remedied until there is now an annual surplus and each year there appears less and less necessity of imposing special taxes for the various public works which the country needs imperatively and the government's reserve fund has increased and also the sum set aside for the amortization of the foreign debt. There has been established a Farmers' Bank which has advanced over £9,000,000 (\$45,000,000) to the cultivators of the soil through the medium of co-operative societies under the patronage of the government. Until 1885 resident Europeans were exempt from taxes, occupying a privileged situation, thanks to the capitulation privileges granted at the time the

Turks were defeated. In the year mentioned, however, the several powers interested declared resident Europeans subject to several taxes, such as the house tax, stamps and licenses, etc., but these provisions were not enforced until 1891. The 1913 budget estimated the revenues from all sources at \$8,065,000 and the disbursements at \$78,150,000. The chief sources of revenue are land taxes, about \$27,500,000 annually, railways (\$19,000,000), customs (\$11,000,000) and tobacco (\$19,000,000). The chief items of disbursement are: administration costs (about \$25,000,000 yearly), the debt service (\$17,500,000 yearly) and the railways (\$10,000,000 yearly). The foreign debt of Egypt dates from 1862 when loans were made to wipe out the floating debt. Other loans followed and finances were subject to the joint direction of France and England until 1879. In 1876 the several issues were consolidated into one debt of \$455,000,000. The administration of the finances is almost entirely in British hands. In 1912 the foreign debt consisted of the 3 per cent guaranteed loan of \$36,592,500, the 3½ per cent privileged debt of \$155,638,900, the unified 4 per cent debt of \$279,859,800 and the 4½ per cent dominion loan of \$1,017,100, a total foreign debt of \$473,108,300, with yearly interest of \$17,803,475. Reserve fund established in 1880-90 amounted in 1911 to \$29,238,060. At the beginning of 1913 the foreign debt was reduced to \$471,748,400. The revenue for 1915-16 was \$73,780,000 and the expenditure \$79,500,000. In January 1915 the public debt stood at \$470,144,200, the charges for interest and sinking fund amounting to \$17,756,330.

**Money, Weights and Measures.**—By decree of 14 Nov. 1883 the monetary unit of Egypt is the Egyptian pound, divided into 100 piastres, weighing 8.5 grammes, .875 fine and containing therefore 7.4375 grammes of pure gold. Therefore £ E = £1—0s—6¼ = \$5.00. The piastre (*kush* or *kurush*) equals 5 cents, and is divided into 10 parts called *ochrel guerche*.

The principal pieces in circulation are the pound; 20, 10, 5, 2 and 1 piastre pieces (silver); 1, ½, 1/5 and 1/10 of a piastre (nickel), and ½ and 1/40 piastre for copper pieces.

The unit of capacity is the *ardeb*, equal to 43.759 English gallons or 5.44739 bushels. Its approximate weight is 315 *rotls* for wheat and maize, 320 *rotls* for beans, 250 *rotls* for barley and 260 *rotls* for cotton seed. Weights are the *okieh* = 1.3206 English ounces, the *rotl* = 0.99069 English pounds, the *Oke* = 2.7513 pounds and the *Kantor* = 100 *rotls* or 36 *okes* or 99.0492 pounds. Linear measures are the *diraa baladi* = 22.8350 inches; the *diraa-mimari* = 29.5281 inches, and the *kassaba* = 139.7663 inches. For square measure: the *feddan* = 7.468 square pics; *pic* = 0.562 square metres = 0.936 inches.

**Railways, Telegraphs and the Post-Office.**—On 1 Jan. 1915 there were 2,065 miles of railway under state control (exclusive of the Sudan Military Railway) and 816 miles of light railways privately owned. In 1914, 3,594,049 tons of freight were carried, and 24,215,000 passengers, with net receipts of \$1,061,912. Telephones and telegraphs belonging to the Egyptian government on 1 Jan. 1915 had a total length of 9,230 kilometers, the length of the wires being 21,882 kilometers. The Eastern

Telegraph Company has (by concessions) lines across Egypt from Port Said to Suez and from Alexandria (via Cairo) to Suez. There were in 1914 1,937 post-offices and stations in Egypt.

**Army and Navy.**—On 19 Sept. 1882, the organization of the Egyptian army was placed in the hands of a British officer, with the title of Sirdar. Military service is compulsory, but since a very small army is maintained only a very small portion of the men of military age are in the ranks. The term of service is three years. The forces consist of administration officials, music corps, four squadrons of cavalry, nine Egyptian and seven Sudanese battalions of infantry, a camel corps, artillery and sanitation corps, engineers and railway corps, and a veterinary corps. There is a total of 138 English officers, 709 Egyptian officers and 18,381 English soldiers. The army of occupation, or the English garrison, consists of a cavalry regiment, a battery of artillery, a mountain battery, a company of engineers and four battalions. It is stationed in the Delta. Moreover, in the Sudan, there is a battalion of infantry and a detachment of artillery. The total English force numbers 6,067 men of all arms. The Egyptian government makes an annual budget provision of \$750,000 for the maintenance of the English force. The navy consists of a steamer for coast and lighthouse service, five revenue cutters, two of which are steam vessels, five skiffs, 11 schooners and one school ship. On the Upper Nile are three steamers and eight gunboats. No details are available since the outbreak of the European War, when the defense of the country was undertaken largely by troops from the overseas Dominions, aided by British warships in the Suez Canal. See section *History—Egypt during the European War*.

**Ethnology.**—The origin of the Egyptians is unknown. Ethnologists have endeavored to establish a relationship with the peoples of the south, any differences being accounted for by variations of environment. Philologists have looked to the East for their next of kin as regards descent as well as speech. It has been thought by some that an Eastern origin is indicated by the fact that the Egyptian oriented himself by looking to the south, but this is rather due to the direction of the Nile. Between the results thus reached there is an evident conflict, with no obvious means of harmonizing them. It has been suggested that the facts can best be reconciled upon the theory, not of a migration of a whole people, but of an incursion of a smaller band who succeeded in establishing their rule over the original people and in gradually forcing their own language, as that of a ruling class, upon those whom they had subjugated, while still the ancient ethnological type persisted. This theory is merely a working hypothesis, and it has reference to a time long anterior to any historical monuments or traditions, for long before the earliest extant inscription Egypt was a united country under the rule of native kings, and possessed of a well and independently developed government and of well-defined classes of society. Judging from the language and the physical condition of the mummies of ancient Egypt, the population appears to have been of mixed origin, part Asiatic and part Nigritic; and there seems also to have been an aboriginal race of copper color, with rather thin legs,



large feet, high cheek-bones and large lips; both types are represented on the monuments.

A national name for the people as such never seems to have existed. Among themselves they were *Romet*, men, *par excellence*; all others were inferior races, "miserable" Cushites, Libyans, Asiatics, *Shasu*. They themselves were the wards of the great gods, and Pharaoh was descended from Ra, who had himself once ruled in Egypt. Other peoples were descended from the enemies of their deities, and when Ra had overthrown them at Edfu a portion escaped, those southward became Ethiopians, northward Asiatics, westward Libyans, eastward Bedouin.

Personal experience has warped the judgment of observers as to their character. Herodotus praises the cleverness of the Egyptians and their excellence of memory; Diodorus declares them to be the most grateful of people; the Emperor Hadrian characterized them as "thoroughly frivolous, unstable, following every rumor, refractory, idle and libelous." The modern notion is that they were so occupied with the thoughts of the future as to be oblivious of the present. There is undoubtedly a degree of truth in all of these estimates, but a broader survey shows that they were energetic in their undertakings, as is evidenced by their temples and the Pyramids, still the wonder of the world; possessed of sufficient skill to perform by force of numbers labors which would test modern mechanics severely, practical in their methods of utilizing the forces of nature; peaceable as compared with other nations, and little given to love of novelty; artistic in their execution and accurate in their observation; a people given to realism, unversed in literary arts, devoted to agricultural pursuits, developed within narrow limits, and little affected by external and foreign influences.

The peasant class, or Fellahin, is the most numerous class in the population of the present day and is indigenous. They are to a certain extent descendants of the ancient Egyptians, but they have been subjected to crossings and have embraced Mohammedanism. Next in number are the Copts, the descendants of the ancient Egyptians who embraced and still cling to the Christian religion. (See *Copts*). Though comparatively few in number (about 600,000), their education and useful talents enable them to hold a respectable position in society filling the posts of clerks, accountants, etc. With these aboriginal inhabitants are mingled in various proportions Turks, Arabs (partly Bedouins), Armenians, Berbers, negroes, and a considerable number of Jews, Greeks and other Europeans. The Turks hold many of the principal offices under the government. The great bulk of the people are Mohammedans, the Christians being only about 7.5 per cent. The Egyptians in the mass are quite illiterate, but under the supervision of the Ministry of Public Instruction progress is being made.

The language in general use is Arabic.

The Fellahin, the most superior type of the Egyptian, are a fine race, handsome, of excellent physique, and courteous in their manners. In northern Egypt they are of a yellowish complexion, growing darker toward the south, until the hue becomes a deep bronze. Mr. Lane, the best authority upon the subject, speaks highly of their mental capacity, and gives them credit

for uncommon quickness of apprehension and readiness of wit. They are highly religious, and are generally honest, cheerful, humane and hospitable. But these are exceptions in a mixed population of Bedouins, negroes, Abyssinians, Turks, Syrians, Greeks, Armenians, Jews and Europeans.

**Population.**—The population, according to the census of 1907, was 11,189,978, and is estimated at present to be about 12,500,000. Of this total 5,667,074 were males, and 5,620,285 females. The population was divided by nationality as follows: Egyptians, 10,903,677; Ottomans, 69,725; Sudanese, 65,162; Greeks, 62,973; Italians, 34,926; English, 20,653; French, 14,591; Austro-Hungarians, 7,704; Russians, 2,410; Germans, 1,847; Persians, 1,385; all others, 4,925. In 1800 the French estimated the population at 2,460,200. In 1821 the census returns showed 2,536,400; that of 1846 4,476,440; of 1882 6,831,131; 1897, 9,734,405; 1907, 11,189,978. According to its religious beliefs the population is divided as follows: Mussulmans, 10,269,445; Copts, 706,322; Orthodox Greeks, 76,953; Roman Catholics, 57,744; Protestants, 12,736; Jews, 38,635; others, 28,143. Of the Egyptian population over 10 years 62.65 per cent was engaged in agriculture and of the foreign element less than 1 per cent; 16.27 per cent of the natives engage in commerce and industry, in which are employed 47.85 per cent of the foreigners.

**History.**—The history of Egypt and its civilization covers a period that the most recent studies estimate as extending over 10,000 years. From this, according to Petrie, should be deducted the 3,500 years that witnessed the first stumbling prehistoric effort at expression, and in addition the centuries of Græco-Roman domination, and the period from the beginning of Christianity down to our days. This leaves a period of over 50 centuries during which the religious, artistic, social and political ideas of the people underwent little change, and did not absorb any elements of the civilization of Asia and the rest of the Mediterranean littoral. Egyptian chronology, to which reference is constantly made in treating of the monuments executed during the 30 dynasties deemed historical, arrives only at exact historical certitude from the period of the conquest of Alexander the Great (about 340 B.C.). The divisions established by historians and archaeologists are based chiefly on the fragments of Egyptian history written in Greek in the 3d century B.C. by Manetho, priest of Heliopolis. It contained the lists of the kings, from the 1st dynasty down to Alexander. But unfortunately only about one-third of the original has come down to us. (The fragments and lists of kings were published in Müller's 'Fragmenta historicorum græcorum,' Paris 1848). The exactitude of the periods at which began the several dynasties varies greatly. The Egyptians divided the solar day into 24 hours, the latter they subdivided into minutes, seconds and thirds of seconds; 10 days formed a week, and 3 weeks one month, 12 months (360 days) and 5 complementary days formed the Egyptian year. In remote times the year consisted of 360 days, but the premature arrival of the seasons being noted, in the reign of Pepi II (6th dynasty), the five complementary days were added. The year was divided into three

seasons: the first (*Shat*), commenced 19 July, terminated about 15 November and corresponded to the period of the inundation of the Nile; the second (*Pert*) from 15 November to 15 March, and the third (*Shmu*) from 15 March to 19 July. There is as we have noted above considerable difference among Egyptologists in regard to fixing the dates of the various dynasties. Myer and Sethe have assigned the beginning of the 1st dynasty to a date corresponding approximately to the year 3400 B.C. Breasted, Erman and Steindorff also favor this date. A noteworthy circumstance in this connection is the complete lack of any reference to eclipses in the Egyptian texts so far interpreted. The history proper divides itself into six great periods: (1) The Pharaohs or native kings; (2) the Persians; (3) the Ptolemies; (4) the Romans; (5) the Arabs; (6) the Turks.

*The Pharaohs.*—The main sources of its history under the Pharaohs are the Scriptures, the Greek writers Herodotus, Diodorus and Eratosthenes, and fragments of the writings of Manetho (an Egyptian priest in the 3d century B.C.). From the Scriptures we learn that the Hebrew patriarch Abraham went into Egypt because of a famine that prevailed in Canaan. He found the country ruled by a Pharaoh, Egyptian *per da*, meaning "Great house," the Egyptian term for king. The date of Abraham's visit, according to the chronology of the Hebrew text of the Bible, was 1920 B.C.; according to the Septuagint, 2551; while Bunsen fixed it at 2876. Nearly two centuries later Joseph, a descendant of Abraham, was sold into Egypt, as a slave to Potiphar, the captain of the guards of another Pharaoh, whose prime minister or grand vizier the young Hebrew eventually became. Joseph's father, Jacob, and his family, to the number of 70, accompanied, as Bunsen conjectures, by 1,000 or 2,000 dependents, followed their fortunate kinsman into Egypt, where they settled in a district called the land of Goshen. There they remained until their numbers had multiplied into two or three millions, when under the lead of Moses they revolted and quitted Egypt to conquer Canaan.

*Ptolemaic Period.*—When Alexander's army occupied Memphis the numerous Greeks who had settled in Lower Egypt found themselves the ruling class. Egypt became at once a Greek kingdom, and Alexander showed his wisdom in the regulations by which he guarded the prejudices and religion of the Egyptians. He founded Alexandria as the Greek capital, which became the emporium of commerce and centre of learning for several centuries. Ptolemy I was succeeded by Ptolemy II, Philadelphus. He was successful in his external wars, built the Museum, founded the famous library of Alexandria, purchased the most valuable manuscripts, engaged the most celebrated professors, and had ordered 70 Hebrew sages to translate the Hebrew Scriptures into the Greek language, hence known as the Septuagint, and the Egyptian history to be written by Manetho. His successor Ptolemy III, Euergetes, pushed the southern limits of his empire to Axum. Ptolemy IV, Philopator (221–204 B.C.) warred with Antiochus, persecuted the Jews and encouraged learning. Ptolemy V, Epiphanes (204–180 B.C.) experienced repeated rebellions, and was succeeded by Ptolemy VII, Philometor (180–145

B.C.) and Euergetes (145–116 B.C.) by Ptolemy X., Soter II and Cleopatra, till 106 B.C. and by Ptolemy XI, Alexander I (87 B.C.) under whom Thebes rebelled; then by Cleopatra, Berenice, Ptolemy XII, Alexander II (80 B.C.), and Ptolemy XIII, Neos Dionysius (51 B.C.), and finally by the celebrated Cleopatra. After the battle of Actium (31 B.C.) Egypt passed into the condition of a province of Rome, governed always by a Roman governor of the equestrian, not senatorial, rank.

The Egyptians had continued building temples and covering them with hieroglyphic inscriptions as of old; but on the spread of Christianity the older religions lost their sway. Then the Christian catechetical school arose in Alexandria, which produced Clemens and Origen. Monasteries were built all over Egypt; Christian monks took the place of the pagan hermits, and the Bible was translated into Coptic. See EGYPTIAN ARCHAEOLOGY and EXPLORATION; EGYPTIAN ARCHITECTURE; EGYPTIAN ARTS; EGYPTIAN LANGUAGE and WRITING; EGYPTIAN LITERATURE; EGYPTIAN MUSIC; EGYPTIAN RELIGION and SOCIOLOGY; MOSES; PHARAOH; PTOLEMY; CLEOPATRA.

*Christian Era.*—On the division of the great Roman empire by Theodosius (337 A.D.) into the Western and Eastern empires, Egypt became a province of the latter, and sank deeper and deeper in barbarism and weakness. It then became the prey of the Saracens, 'Amribu-el-asr, their general, under the Caliph Omar, taking Alexandria, the capital, by assault. This happened 641 A.D., when Heraclius was the emperor of the East. As a province of the caliphs it was under the government of the celebrated Abbassides—Harun el-Rashid and Al-Mamon and that of the famous Sultan Saladin. The last dynasty was, however, overthrown by the Mamelukes (1240), and under those formidable despots the last shadow of former greatness and civilization disappeared. Selim, Sultan of the Turks, eventually (1516–17) conquered the last Mameluke sultan, and Egypt became a Turkish province, governed by a pasha. After this it was the theatre of internal wars by the Mameluke beys against the Turkish dominion, which was several times nearly extinguished. Confusion and civil war between the different factions of the Mamelukes continued to prevail till 1798, when the French invasion under Napoleon Bonaparte united their chiefs in self-defense; but the Mameluke army was all but annihilated in the battle of the Pyramids. The French then conquered the whole of Egypt and held it till 1801, when they were driven out by the British under Abercromby and Hutchinson.

On the expulsion of the French the Ottoman Porte effectually urged its claim to sovereignty, and the accession of the Albanian soldier Mohammed 'Ali to the pashalic in 1805 imparted a galvanic prosperity to Egypt by the merciless destruction of the turbulent Mamelukes (whom a disastrous British expedition in 1807 vainly sought to restore), the formation of a regular army, the increase of security, the improvement of the irrigation and the introduction of the elements of European civilization. In 1816 Mohammed 'Ali reduced part of Arabia, brought it under his sway by the generalship of his son, Ibrahim; in 1820 he annexed Nubia and part of the Sudan; and from 1821 to 1828

his troops, under Ibrahim, occupied various points in the Morea and Crete, to aid the Turks in their war with the insurgent Greeks. The Egyptian fleet was annihilated at Navarino, and Ibrahim remained in the Morea till forced to evacuate by the French army, under Maison, in 1828. In 1831 Ibrahim began the conquest of Syria, and in the following year totally routed the Ottoman army at Koniya, after which the Porte ceded Syria to Mohammed 'Ali on condition of tribute. War breaking out again, the victory of Nisib in 1839 would perhaps have elevated him to the throne of Constantinople; but the quadruple alliance in 1840, the fall of Saint Jean d'Acre to the British and the consequent evacuation of Syria, compelled him to limit his ambition to the pashalic of Egypt. In 1848 Mohammed 'Ali became imbecile (he died in 1849), and his son Ibrahim sat on his throne for two months, when he died, and 'Abbās Pasha, Mohammed 'Ali's grandson, succeeded him, and was succeeded in turn (1854) by Sa'id Pasha, youngest son of Mohammed 'Ali. M. de Lesseps then obtained the co-operation, hitherto withheld, of the Egyptian government in his scheme of the Suez Canal, which was opened in 1869. Sa'id was succeeded (1863) by his nephew, Ismail, son of Ibrahim, who by a firman purchased from the Sultan (1866) the hereditary title of Khedive. He obtained the hereditary title of Khedive to the throne of Egypt, direct from father to son, instead of descending, according to Turkish law, to the eldest male of the family, and in 1872 the Sultan granted to the Khedive the rights (withdrawn in 1879) of concluding treaties and of maintaining an army, and virtually gave him sovereign powers. Thus secure on an hereditary throne, Ismail began a series of vast internal reforms, built roads, bridges, lighthouses, railways and telegraphs, reorganized the postal service, improved the harbors at Suez, Port Sa'id and Alexandria, supported education, and introduced mixed courts of law. Extending his dominions southward, he annexed Dar-Fūr in 1874, and in that and the following year further conquests were made. The condition of the finances led to the establishment of "dual control" by Great Britain and France, and in 1879 Ismail was forced to abdicate under pressure of the British and French governments, and was replaced by his son, Tewfik. His position was soon threatened by the so-called National party with Arabi Pasha at its head, who aimed at his deposition and at the abolition of European intervention. In May 1882, a rising took place in Alexandria, when many Europeans were killed and their houses pillaged. The Khedive fled from Cairo, where Arabi remained autocrat. The French refusing to interfere, Great Britain determined to act, and on 11 July a British fleet bombarded the forts at Alexandria, causing the rebels to retreat. In August a force under Sir Garnet (afterward Lord) Wolseley landed at Ismailia, and on 13 September Arabi's forces were totally defeated at Tel-el-Kebir and the rebellion crushed, Arabi and his associates being banished. Before this a rebellion against Egyptian rule had broken out in the Sudan under the leadership of Mohammed Ahmed, who professed to be the Mahdi or divinely-sent Mohammedan conqueror. His

followers soon became numerous, defeated Egyptian troops that opposed them, and threatened the existence of all the Egyptian garrisons in the Sudan. In 1883 they annihilated an Egyptian force under Hicks Pasha near El Obeid in Kordofan, and in 1884 Osman Digna, as representing the Mahdi, defeated another force under Baker Pasha near Suakim. British troops were now dispatched to Suakim, and at El Teb and Tamai severe defeats were inflicted on the Arabs by General Graham. Meantime General Gordon had been sent to Khartum to withdraw the garrisons from the Sudan, but he was shut up in the town for nearly a year, and perished before the relief expedition under Sir Garnet Wolseley could reach him (January 1885). The Sudan was then given up, and the southern boundary of the Egyptian dominions fixed at Wady-Halfa.

In 1892 Tewfik died, and was succeeded by his son, Abbas Hilmi, who is the seventh viceroy and third khedive of Egypt. In 1896 an Anglo-Egyptian expedition for the reconquest of the lost provinces was dispatched under Sir Herbert (afterward Lord) Kitchener. Dongola was soon occupied. Abu Hamed was captured in the following year, and (8 April 1898), the insurgents were defeated in a battle near the confluence of the Atbara. Finally (2 Sept. 1898) the forces of the Khalifa, as the Mahdi's successor was called, were defeated with great slaughter at Omdurman, near Khartum. The territory thus reconquered was placed under a governor-general, and was rapidly organized. A subsequent attempt of France to occupy Fashoda and enforce a claim to the Bahr-el-Ghazal "Blue River" Valley led to some friction with Great Britain.

**Egypt During the European War.**—Owing to the entrance of Turkey into the war on the side of the Central Powers, and to the adhesion of the khedive to the king's enemies, a British protectorate was declared and the Khedive Abbas Pasha deposed on 18 Dec. 1914. Prince Hussein Kamil, the eldest living prince of the family of Mohammed 'Ali, a former viceroy of Egypt, was appointed in his stead, under the title of Sultan of Egypt. Two unsuccessful attempts at his assassination have been made (8 April and 9 July 1915). Sir Arthur McMahon was appointed British high commissioner. Turkish armies under German leadership have made successive attempts to attack the Suez Canal as preliminaries to an invasion of Egypt. The most dangerous of these incursions were: (1) On 2 Feb. 1915 the Turks attempted to cross near Toussoum, 35 miles north of Suez; (2) on 23 April 1916 an attempt was made at the Quatia Oasis, 25 miles east of the canal, on the road to El Kastara; (3) the most formidable effort was made on 4 Aug. 1916 when 14,000 Turks attacked the British position near Romani, 22 miles east of Port Said and just north of Katia, on a front of seven or eight miles. The British troops, under the command of Sir Archibald Murray, and composed mainly of Australians and New Zealanders, succeeded by a strategic retirement in involving the Turks in the sand-dunes, and then fell upon their rear, and succeeded in taking 2,500 unwounded Turkish and German prisoners. See WAR, EUROPEAN. See also ALEXANDRIA; CAIRO; CROMER; EMIN PASHA; GORDON,

GEN. C. G.; KHEDIVE; MAD MULLAH; MOHAMMEDANISM; NAPOLEON; SUDAN; SUEZ CANAL; TEWFIK; WADY-HALFA.

**Bibliography.**—'Annuaire Statistique de l'Égypte' (Cairo Annual); Arminjon, P., 'Situation économique et financière de l'Égypte' (Paris 1911); Artin, Y. P., 'England in the Soudan' (London 1911); Balls, W. L., 'Egypt of the Egyptians' (London 1915); Bréhier, L., 'L'Égypte de 1789 à 1900' (Paris 1901); Colvin, A., 'The Making of Modern Egypt' (London 1906); Cromer (Earl), 'Modern Egypt' (London 1908), 'Abbas II' (London 1915); Weigall, A. E. P., 'History of Egypt from 1763 to 1914' (London 1915).

SAMUEL AUGUSTUS BINION,  
Author of 'Ancient Egypt or Mizraim'; Revised  
by Editorial Staff of the Americana.

**EGYPTIAN ARCHÆOLOGY AND EXPLORATION.** The attention of the world was drawn to Egypt as a rich field for scientific exploration in the early part of the 19th century. M. Bousard, a French officer under Bonaparte (1799), discovered at Fort Julien, near Rosetta, a large block of black granite, with the remains of three inscriptions, the first in hieroglyphs, the second in demotic characters, the third in Greek. This *Rosetta Stone* was taken to England after the capitulation of Alexandria (1801), and presented by George III to the British Museum. It contains a decree promulgated at Memphis, in honor of Ptolemy V, Epiphanes, by the priesthood of Egypt in synod assembled, thanking that sovereign for the benefits which he had conferred on them. They ordered it to be sent to all the temples of the first, second and third rank, there to be engraved on stelæ in the three forms of writing then used throughout the land. When found, half of the hieroglyphic portion of the Rosetta copy was wanting, but the demotic and Greek were nearly complete, and the work of decipherment began with them. The French orientalist Silvestre de Sacy made out in the demotic some of the proper names mentioned in the Greek ('Lettre au Citoyen Chaptal sur l'inscription égyptienne du monument du Rosette' Paris 1802); and the Swede Akerblad, following in his steps, assigned phonetic values to most of the signs employed in the proper names ('Lettre sur l'inscription égyptienne de Rosette adressée au Citoyen S. de Sacy,' Paris 1802). In 1814 Thomas Young, the English mathematician, succeeded in isolating a number of groups which express common names, and even in translating some fragments of demotic phrases. Turning to the hieroglyphs he tried to determine the power of the characters, which being enclosed in cartouches or rings, were known to indicate the names of kings. Thus he read the names of Ptolemy and Berenice, but he failed to analyze them exactly; five only of the values which he proposed for the signs turned out to be true. The problem with which Young had such poor success was solved four years later by Jean François Champollion, who had felt attracted to the study of the Oriental languages from his early youth and published at 24 the famous work 'L'Égypte sous les Pharaons' (2 vols., Paris 1814), on the civilization and history of Egypt. Guided by his thorough knowledge of the Coptic, he

applied himself to the decipherment of the inscriptions, and ascertained very soon that the three kinds of characters found on the monuments, far from representing three independent systems, were three successive developments of one system of writing, of which the hieroglyphs were the prototype, the hieratic and demotic the cursive forms. ('De l'écriture hieratique des anciens Égyptiens,' Grenoble 1821). He then dissected the cartouches which had been studied by Young and proved that the hieroglyphs in them were always taken alphabetically, and that the alphabet thus employed for the rendering of the Greek royal names was the same that had been used from the time of the first dynasties, not only for proper names, but for the common parts of the language. He gave a general outline of his system to the Académie des Inscriptions on 22 Sept. 1822, a day famous as marking the foundation of Egyptology. Then he completed his revelations, and explained fully his method in his 'Précis du système hieroglyphique des anciens Égyptiens' (Paris 1824; 1828). He spent the last eight years of his life in working out the principles which he had established for the resurrection of the old Egyptian world. In 1828-30 he searched Egypt from Alexandria to Wady-Halfa with the help of other French and Italian archæologists. Upon his return he was made professor of Egyptian literature at the Collège de France. He died 4 March 1832, having overtaxed his strength during the journey to Egypt. His rapid success had raised up a host of detractors and opponents. Klaproth criticized his work with a bad faith and virulence which even death did not abate; Spohn and Seyffarth started a rival system, which was rejected in Europe by 1855, but continued to find some degree of acceptance in the United States until about 1880. The general public, however, had received his labors with delight and after his death men of every nation took up his teachings and advanced the work he had so well begun. Nestor Lhôte, Charles Lenormant and Dulaurier in France; Salvolini, Rosellini, Ungarelli, in Italy; Seemans in the Netherlands; Wilkinson, Birch and Osborn in England. Champollion-Figeac devoted himself to the memory of his younger brother and published the most important of his unfinished books, his 'Lettres écrites d'Égypte' (Paris 1833); and his 'Grammaire Égyptienne' (ib. 1836-41); his 'Dictionnaire Égyptien en écriture hieroglyphique' (ib. 1841-46); 'Monuments de l'Égypte et de la Nubie' (ib., 1835-75), completed by Maspero. Since then the story has been a perpetual record of success and discoveries. Lepsius analyzed critically in his 'Lettre à M. Rosellini sur l'alphabet hiéroglyphique' (Rome 1837) the structure of the old language, and elucidated the origin and mechanism of the syllabic characters, the existence of which had only been surmised by Champollion. Lepsius, however, early left philological for historical and archæological researches. From 1837 to 1885 nearly every year was marked by the appearance of some important work from his pen: 'Das Todtenbuch der Ägypter'; 'Über die XII ägyptische Königsdynastie'; 'Einleitung in die Chronologie'; 'Über den ersten ägyptischen Götterkreis'; 'Königsbuch der alten Ägypter,' etc. Large portions of these have become anti-

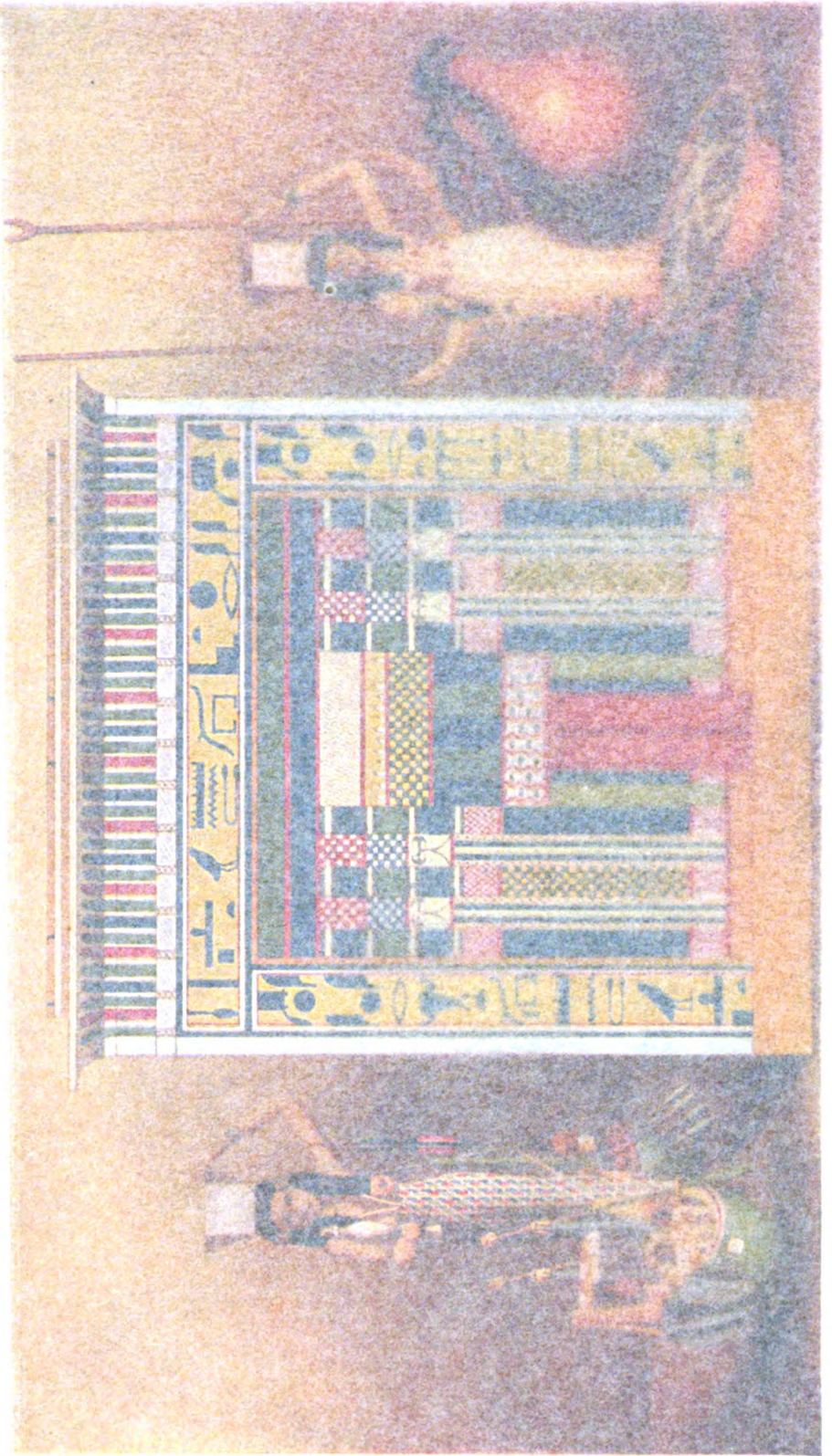

1. The first part of the document  
 2. The second part of the document  
 3. The third part of the document  
 4. The fourth part of the document  
 5. The fifth part of the document  
 6. The sixth part of the document  
 7. The seventh part of the document  
 8. The eighth part of the document  
 9. The ninth part of the document  
 10. The tenth part of the document

11. The eleventh part of the document  
 12. The twelfth part of the document  
 13. The thirteenth part of the document  
 14. The fourteenth part of the document  
 15. The fifteenth part of the document  
 16. The sixteenth part of the document  
 17. The seventeenth part of the document  
 18. The eighteenth part of the document  
 19. The nineteenth part of the document  
 20. The twentieth part of the document

21. The twenty-first part of the document  
 22. The twenty-second part of the document  
 23. The twenty-third part of the document  
 24. The twenty-fourth part of the document  
 25. The twenty-fifth part of the document

26. The twenty-sixth part of the document  
 27. The twenty-seventh part of the document  
 28. The twenty-eighth part of the document  
 29. The twenty-ninth part of the document  
 30. The thirtieth part of the document

31. The thirty-first part of the document  
 32. The thirty-second part of the document  
 33. The thirty-third part of the document  
 34. The thirty-fourth part of the document  
 35. The thirty-fifth part of the document

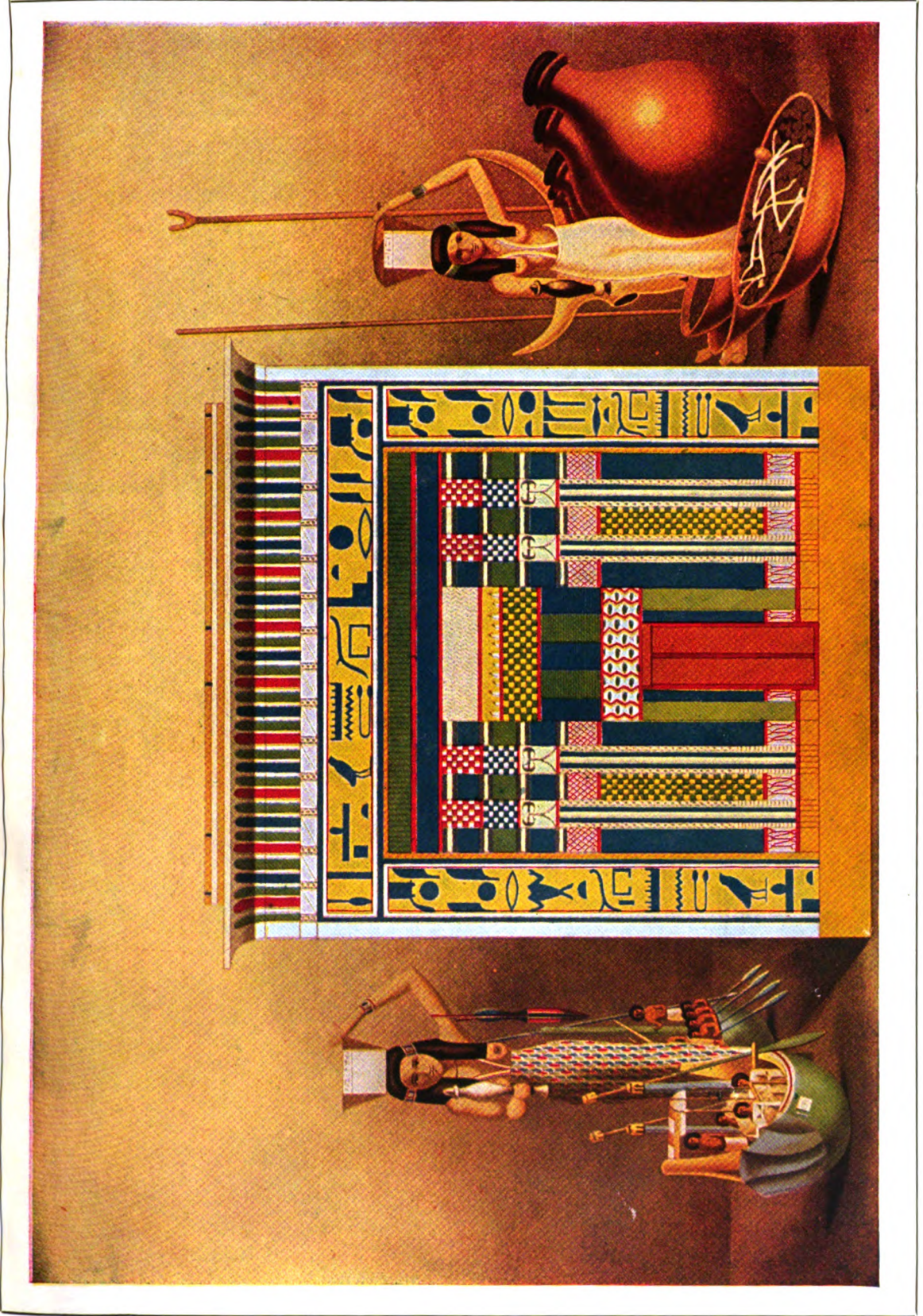

TOMB IN THE VALLEY OF EL ASSASIF, THEBES, EGYPT





quated, but they formed the solid ground upon which the chronology and history of ancient Egypt have been built up. His three years' stay in the Nile Valley at the head of a commission of German scientists (1842-45) produced the gigantic 'Denkmäler aus Ägypten und Äthiopien' (12 vols., Berlin 1849-59), in which all the historical texts known at the time were reproduced by the skilful hand of Weidenbach. Bunsen popularized the ideas of Lepsius in his 'Ägyptens Stelle in der Weltgeschichte' (Hamburg 1849); Brugsch applied himself to the demotic texts ('Scriptura Aegyptiorum demotica,' Berlin 1848); 'Grammaire démotique' (ib. 1885). While things went thus in Germany, Emmanuel de Rougé commenced his labors in France with his 'Examen critique de l'ouvrage de M. le Chevalier de Bunsen,' in which the merits of Bunsen's and Lepsius' work were fully recognized, while their errors and fallacious hypotheses were pointed out with a vigor of method and a certainty which placed the young author at the head of Egyptologists. He remodeled the grammar in his 'Chrestomathie Égyptienne' (Paris 1867-76), he called back to life the first dynasties in 'Recherches sur les monuments qu'on peut attribuer aux six premières dynasties de Manithon' (ib. 1866), and in his pamphlets, he was the first who really translated whole Egyptian books and inscriptions, both hieroglyphic and hieratic. He gave a new impulse to the study not only in France, where Chabas, Deveria, Pierret and Maspero followed him, but also in England, where his influence was felt by Birch, Hincks, Renouf, Le Page and in Germany, where Brugsch, Dümichen and Ebers seconded the efforts of Lepsius. Brugsch left many monumental works, the great faults of which are lost in greater merits. With the exception of Weidemann the more recent German school inclines more and more to grammars and philology under the lead of Adolf Erman. The French school, while not neglecting philology, has directed much of its strength toward history and archæology. Young Egyptologists are sent every year to Egypt to excavate, draw, copy and publish the monuments. They are helped in the work of finding and preserving the remains of antiquity by an Anglo-American society, the Egypt Exploration Fund, the first secretary and real promoter of which was Amelia B. Edwards (1882-92). In 1883 they sent out their first agent, E. Naville of Geneva, and he cleared the site of Pithom in the land of Goshen. Since then Naville, Flinders Petrie, Griffith, Gardner and Newberry have been at work. Naucratis has come to light, Tanis and Bubastis, the Pyramids of the Fayum, the tombs of Beni-Hasan and El-Amarna have yielded unexpected treasures of archæological and historical lore. The last few years have seen wonderful discoveries in Egypt, for the tombs of the kings of Abydos have been opened and the treasures which have been found bring us face to face with archaic history. Among the remarkable finds were a carved slate slab showing King Nâr-mer smiting his enemy, an ebony table, a bar of gold, gold jewelry, including bracelets, and a royal sceptre. The oldest group of jewelry in the world is undoubtedly the four bracelets of the queen of King Zer or Teta (4366 B.C.), which was discovered

with a portion of the mummy in a hole in a wall. This is 1,500 years earlier than any other jewelry thus far identified. The bracelets show a wonderful perfection in the soldering of gold. They also show the turning point in the development of Egyptian art; the finest bracelets are formed of alternate plaques of gold and turquoise, each surmounted with a royal hawk. The turquoise hawks are clumsy, of a more archaic form than those on the gold pieces.

An American archæologist, Theodore M. Davies, has made one of the most interesting discoveries of recent years in excavating the tomb of Thothmes IV of the 18th dynasty. The tomb contained the chariot in which he rode at Thebes. Like other royal tombs it consisted of a gallery cut in the heart of the mountain. After sloping downward for a considerable distance it is interrupted by a deep square well; on one of the walls is a band of paintings. On the farther side of the wall the passage turns back, and finally opens into a large chamber, at the extreme end of which is a magnificent sarcophagus of granite covered with texts from "The Book of the Dead." On either side are smaller chambers; the floor of one of them was covered with the offerings made to the dead king, consisting of mummified loins of beef, legs of mutton and trussed ducks and geese. Clay seals with the name of the Pharaoh had been attached to the doors of the chambers, and it is stated the raised portions of the seals had been smeared with blue ink before being pressed on the clay. A great many of the objects in the tomb of Thothmes were found to be broken, and this was explained by a hieroglyphic inscription on one of the paintings which adorn the walls of the vestibule to the chamber in which the sarcophagus was found. That inscription states that the tomb was plundered by robbers, but that it had been restored as far as possible to its original condition by Hor-em-heb, the reigning Pharaoh. The floor was covered with vases, dishes, symbols of life and other objects in blue faience. Unfortunately, nearly all of them had been wantonly broken, though in some cases the breakage had been repaired in the time of Hor-em-heb. Equally interesting is a piece of textile fabric into which hieroglyphic characters of different colors have been woven with such wonderful skill as to present the appearance of painting on linen. The chariot is one of the finest specimens of art that have come down to us from antiquity. Along with the chariot was found the leather gauntlet with which the king protected his hand and wrist when using the bow or reins.

Later excavations at Abydos have brought to light the royal tomb of Menes, of the first dynasty, in which was found a large globular vase of green glaze, with Menes' name inlaid in purple. Thus polychrome glazing is taken back thousands of years before it was previously known to exist. There are also several pieces of delicately carved ivory of that age. One represents the figure of an aged king, which, for subtlety of character, stands in the first rank of such work, and ranks with the finest work of Greece and Italy. A camel's head modeled in pottery takes back its relation to Egypt some 4,000 years. Hitherto no trace of the camel had appeared before Greek times. The ivory carv-

ing of a bear also extends the fauna of early Egypt.

Records begin to appear with the 3d dynasty of Manetho. The Sphinx of Ghizeh is certainly older, but being uninscribed, it is not known to which king or dynasty it belongs. A few stelæ bear the name of Sondon (2d dynasty), and the step pyramid of Sakkarh purports to be the tomb of Tosiri (2d dynasty). These, however, are isolated instances and an unbroken line of monuments only begins under Snofroni, the last Pharaoh of the 3d dynasty, about (4300 B.C.). From his time to the death of Pepi II (about 3800 B.C.) the necropolis of Ghizeh, Sakkarh, Dashour and Midoum, tombs of feudal families at Zawret-el-Maetin, at Sheik-said, the rock graffiti of Wadi-Magharah in the Sinaitic peninsula, furnish material enough to trace the succession of the kings and call back to life the whole civilization of those primæval ages. The series breaks off after Pepi II, but a few scarabs and other objects are the only records we possess of the Heracleopolitan house. With the 11th dynasty the monuments came to light again in great numbers and are dispersed all over the Nile Valley, in the grottoes of Beni-Hasan, Bersheh, Siut, Assouan, in the tombs of Thebes and Abydos, in the temples of Nubia and in the Delta cities, in the Fayum pyramids and the inscriptions of Sinai. There are many inscriptions and statues of the 13th and 14th dynasties, and the area of ground they cover from the fourth cataract to the sea shows the extent of the Egypt of that day. The invasion of the Hyksos suspended for at least 400 years the production of monuments (about 2100 B.C.), and nothing remains of their kings except a few names scratched on the statues of the old Pharaohs. Egypt revived after their expulsion and the three Theban dynasties of the New Empire (1750-1100 B.C.) enriched by the spoils of Asia and of Ethiopia, covered the banks of the Nile with temples and palaces, the remains of which are counted today in hundreds. The Roman Cæsars continued the constructions and the reigns of the Flavians and Antonines are recorded by many monuments. The impulse died out about 250 A.D.; Philippus is the last emperor whose name is engraved officially in the hieroglyphic character. The English have recognized French intervention in the direction of the Cairo Museum which has a right to one-half of all discoveries of antiquities, etc., made in Egypt. Gaston Maspero was appointed director in 1899 of the Service of Antiquities, as this branch is known, and was succeeded in October 1914 by Pierre Lecau. Several permanent commissions are at work in various parts of the country. Consult Champollion, 'Monuments de l'Égypte' (1843); Mariette, 'Monuments of Upper Egypt' (1877); Petrie, 'History of Egypt' (1894); Rawlinson, 'History of Ancient Egypt' (1881).

**EGYPTIAN ARCHITECTURE.** The most ancient monuments of the world's architecture in stone are those of the Nile Valley. The ruins of some ancient Chaldean buildings are probably of earlier date, but they are almost formless piles of sun-dried brick, while the tombs and pyramids of the early Egyptian dynasties are many of them in excellent preservation. The people who built them were probably of Asiatic origin but long-settled along

the Nile, and were a highly civilized race thousands of years B.C. It is customary to divide the history of ancient Egyptian art into five periods: (1) the Ancient (or Memphitic) Empire, cir. 3400-2160 B.C., comprising ten dynasties of kings; (2) the Middle Empire, with Thebes as capital, 2160-1788 B.C., two dynasties; (3) the Second Thebaic or New Empire (1588-1150 B.C.), comprising the dynasties xvii-xx, and separated from the Middle Empire by the artistic interregnum of the Hyksos or Shepherd kings (Arabs); (4) the Decadence or Saitic period of six dynasties, 1150-324 B.C., which includes the Persian conquest in 525 B.C., and (5) the Ptolemaic and Roman period (324 B.C.-300 A.D.). Then followed a period of over three centuries during which the only architectural works were Coptic churches and monasteries. The Arabs conquered Egypt in 642 A.D., since which date the architecture has been of the Arabo-Moslem or "Saracenic" style, an architecture of mosques, tombs, palaces, baths, fountains and city gates. As this last period, with its infiltrations of Turkish influence since 1517, is treated of under **MOSLEM ART** (q.v.), the present article will be confined mainly to the ancient art of the five periods, with brief reference to the Coptic development.

**Materials and Character.**—There is evidence that the primitive architecture of the Egyptians was of mud ("crude" or sun-dried brick) and wood, but the monuments that have survived to our time are of stone, except for scanty remains of brick. The stones employed were granite of various kinds and limestone; the coarser stone being often furnished with a thin layer of stucco to receive painted decoration. The architecture was almost entirely of tombs and temples, although remains of palaces of the New Empire have been excavated, and there are vestiges of fortifications at Semneh and Gournah. The civilization of Egypt was distinctively monarchical and religious and this is clearly shown in the architecture. There is little change of style until the time of the Ptolemies; what variations there were came about by imperceptibly slow degrees, and an air of changeless duration marks every work of ancient Egypt. Yet earthquakes and the destructive invasions of Persians and Arabs have wrecked partly or completely nearly every one of these massive structures.

All the Egyptian monuments of antiquity were built on the post-and-lintel or wall-and-lintel principle, the arch being used only in minor constructions of brick. But one form of cornice is found—the "cavetto-cornice"—in all the wide range of the ancient monuments through more than 3,000 years. There were no "orders" employed; the columns show a wide variety of capitals, generally reducible to two chief types, the "bud" and the "floral" or campaniform type; and the shafts are with a few exceptions either round or clustered, the former predominating. The "bud" and "floral" types of capital are either simple or compound, the latter predominating in the later periods. All the walls, ceilings and columns of the temples were covered with symbolic or historical decorations, incised and painted in brilliant colors, and sculptured figures of the deified king or of the god Osiris, fronted the entrances and the courtyard piers of the temples.

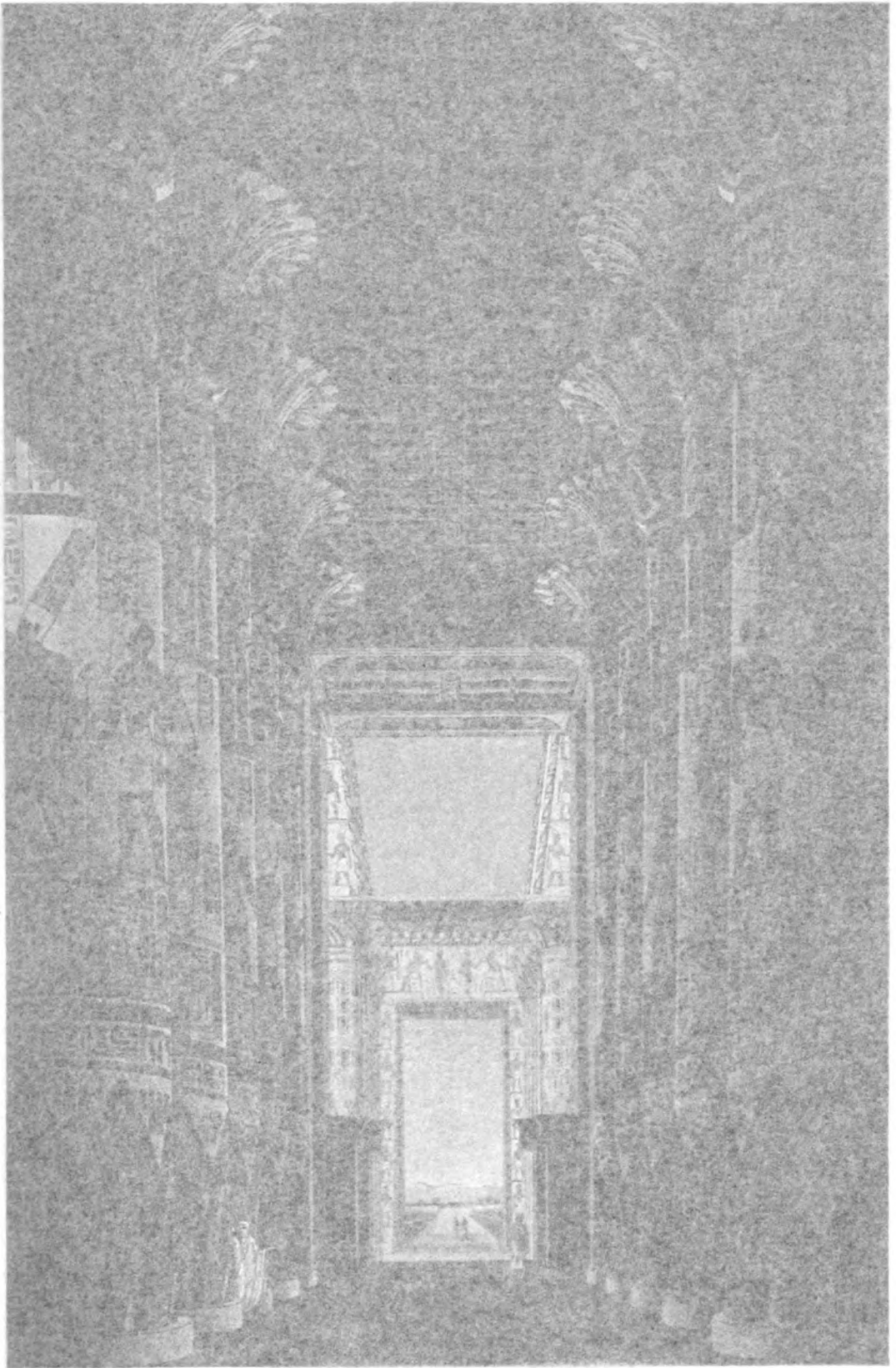

HALL OF COLUMNS

(Restored)

100  
100  
100  
100



HALL OF COLUMNS IN THE TEMPLE OF KARNAK  
(Restored)



**Tombs.**—The religion of Egypt, with its insistence on a future life, assigned an enormous importance to the arts of sepulture, and the tombs are far more numerous than the temples. They are of two chief kinds: the hypogeum or excavated tomb, cut in the rock of the western bank of the Nile, with many passages, chambers and shafts; and the structural or built-up tomb. Of this class there were two chief types, the pyramid (see PYRAMID) and the mastaba or "bench." This latter type, rectangular in plan, had usually sloping walls and a flat top, and contained a variety of chambers and passages, with one or more serdabs or secret chambers, and wells or shafts leading to deep chambers, in one of which the sarcophagus was deposited. Statues of the deceased ("ka-statues") were secreted in the *serdabs* in order to assist in preserving the life and identity of the "ka" or spirit while in the tomb, while the walls were covered with pictures of his daily life and sports in order that the "ka" might by their help enjoy the same pleasures until admitted by Osiris and his assessors to the final home in the underworld. Two fine tombs of this type have been taken down and re-erected in the Metropolitan Museum at New York.

**Temples.**—The fundamental scheme of the Egyptian temple was early developed and remained unchanged in essentials for over 3,000 years. It appears to have been an expansion of the ancient Oriental house-plan, with its enclosing wall, gate, fore-court, reception-hall and living rooms. These became respectively the enclosing wall (sometimes of crude brick), the pylon-gate with its twin truncated pyramid towers or pylons, the fore-court flanked or surrounded with colonnades, the hypostyle or columnar hall for the princes and magnates, and the sekos or sanctuary, with its shrine or "holy of holies" and its surrounding rooms for the priests. These various parts might be duplicated or variously elaborated, but they are to be found in all the temples, large or small.

**Historic Monuments.**—From the Ancient or Memphite Empire there have been preserved to us innumerable tombs and a few temple-ruins. Of the greatest importance are the pyramid-tombs, of which there are nearly a hundred in six groups. They are all royal tombs, but vary in size and shape, some having stepped sides, some being built with two slopes—the lower part steeper than the upper; the remainder are built with a single slope from the square base to the apex. Three of these, at Ghizeh, are far larger than the rest; they belong to the 4th dynasty. The largest is that of Cheops or Khufu, with a base 764 feet square and an original height of 482 feet. The second, of Chephren or Khafra, is slightly smaller; the third, of Mycerinus or Menkhaura, rises 218 feet from a base 254 feet square. The stepped pyramid of Sakkara is older, dating possibly from the First dynasty; it is about 350 by 400 feet at the base and not quite 200 feet high. All of these, and most of the others, were built of limestone with a facing of granite which, however, has in most cases disappeared; they all contain corridors and chambers of elaborate construction. There are also many mastabas and many excavated tombs cut in the rock of the cliffs; the ka-paintings of some of these (e.g., the tomb of Ti) are extraordinarily

detailed and interesting. The temples of this period are all connected with or adjacent to the tombs, to which they served as chapels. The best preserved is that of Chephren, known as the Sphinx Temple, having square piers instead of columns.

The Middle Empire has left us only scanty monuments, of which the most interesting are tombs cut in the cliffs of Beni-Hassan, with columnar porches whose columns somewhat resemble the Greek Doric, hence called "proto-Doric." There have been found scanty remains of temples of this period at Bubastis and at Karnak.

The New Empire was the great age of Egyptian architecture as well as of political greatness under a succession of mighty rulers—the Thutmoses, Amenhoteps, Setis, Rameses and others of the 18th dynasty, of whom Rameses II was the greatest builder. The tombs of this period are all, or nearly all, deep tunnels cut in the rock, with many chambers and corridors; the temples are the largest in Egypt, especially that of Karnak, over 1,200 feet long and 340 wide, whose hypostyle hall with 16 rows of colossal columns, is the grandest ruin in Egypt. Not far away is the great temple of Luxor, next to which in size and splendor is the Ramesseum. Others of almost equal extent and splendor are at Abydos and at Medinet Abu; while at Deir-el-Bahari are the remains of the stupendous hemispeos of Queen Hatshepsut, a sepulchral temple partly excavated and partly structural. At Ipsambul (Abu Simbel) are two colossal temples of Rameses II and III, entirely hewn into the rocky cliff. Many smaller temples, as of Khonsu at Karnak, are in good preservation.

The Ptolemaic-Roman age created the two temples of Hathor and Isis at Denderah, built by Cleopatra; the temple of Edfu and the superb group at Philæ; and the Roman-built temples of Esneh and Koom Ombos, with others in Nubia. All these late temples have screen-walls between the front columns of the hypostyle hall, crested with carved serpents—a new feature; and the capitals of columns are very complex and elaborate.

**Coptic Architecture.**—This is unimportant except in its relations to later Arabo-Egyptian art and to the architecture of Christian Europe and Asia of the same period (4th–7th century). The Copts are the Christian descendants of the ancient Egyptians, and erected, during the above period, many churches and monasteries, mostly of small size. These are interesting chiefly for their use of the arch, of the dome over the sanctuary, and of minutely-detailed surface carving and elaborate wooden screens. It was the Copts who built the earliest Arab mosques in Cairo, and the Arabo-Egyptian style owes much of its character to their work. See ARCHITECTURE; OBELISK; PYRAMID; SPHINX.

**Bibliography.**—Consult for history in general, Breasted, J. H., 'A History of Egypt from the Earliest Times' (London 1906). For the architecture, any of the general histories of architecture; also Maspéro, G. C., 'Egyptian Archæology' (Paris 1910); Perrot and Chipiez: 'History of Art in Ancient Egypt,' and the works of Flinders Petrie, Mariette, Prisse d'Avannies, Rossellini and Wilkinson.

A. D. F. HAMLIN,  
Professor of Architecture, Columbia University.

**EGYPTIAN ARTS. Sculpture, Painting and Minor Arts.**—Sculptors were numerous and very prolific. Several great collections of extant works have been made in modern times; of these the greatest is that of the Museum of Ghizeh, next come those of the Louvre, British Museum, the Vatican, Florence, Turin, The Hague and Berlin. Many works, however, are still *in situ*, in the temples and tombs, both colossal statuary and series of reliefs. Of the Old Empire all the sculptures have been found in tombs. They are realistic and are of value as portraits. In the Middle Empire the official and colossal style was developed in connection with temple architecture reaching its greatest period under the Rameses and Setis of the New Empire. Plastic art was early employed to illustrate the daily life of the subject. Each tomb contained a representation in detail of the person, family and occupation of the deceased, and near the tomb were statues of him or her as they appeared in life. Under the New Empire sunken relief and outline relief come into vogue. Methods of quarrying, carving, polishing and finishing sculptures are represented in these styles together with others. Wood was used in sculpture as is testified by the number of wooden statues remaining, some dating from the Old Empire, the most noteworthy being the famous figure, Sheik-El-Beled. Red granite and basalt were favorite material for statuary, while limestone and sandstone were used more in relief. Red porphyry was especially popular in the later periods. The representation was purely conventional, for the purpose of conveying an idea and not creating an illusion. Perspective was avoided in scenes where several planes of figures appear, the rows being raised one above another. Despite their lack of realism the sculptors were careful of detail. The earliest work of sculpture is the famous Sphinx of Ghizeh now disintegrating under the changed climate. A common portrait is the seated group of husband and wife, found through all the remains of the Old and Middle Empires. The representation of divinities was usually effected by placing an animal's head on a human body, a jackal's head for Anubis; a hawk's for Horus, etc. The gods were worshipped on the opposite walls of a temple and the image of the god was repeated several hundred times on the walls and columns and on the outer pylons. There were also small images of the gods in bronze, glazed earth, etc., used for objects of devotion. Another theme might be termed the political; consisting of the giant king, at whose feet cower many captives. There was little variation in the several representations during long periods. Of particular interest are the reliefs and paintings on the tombs of private persons. A tomb of the Middle Empire represents the migration of a tribe in all its details showing how traveling was done in the age of Moses. Under the New Empire there was a change to the stiff and colossal. Greek art was introduced under the Ptolemies and had a profound influence on Egyptian forms. Painting in ancient Egypt can hardly be called an independent art, being largely an adjunct to architecture. Wall paintings were popular from the 5th to the 13th dynasty and closely resemble the reliefs of the same period in theme and treatment. In portrait sculpture the Egyptians at-

tained extraordinary perfection at an early date, the skill with which they worked in hard stone, such as diorite and basalt, being surprising. Some of the early statues are of colossal size, but a higher style of art is shown in those of ordinary size, though a certain conventional treatment is always apparent. The most usual kind of mural sculpture, a kind peculiar to the Egyptians, is that known as hollow or sunk relief (*cavo-rilievo*). The general outline of the object intended to be represented is cut into the smooth surface of the stone, while at the same time the minor forms and rotundity are represented within the incised outline. By this contrivance the details of the sculptures are protected. Sometimes the outline is excessively deep, at others the surface of the figures is altogether much lower than the general surface of the wall, and in others the outline is but slightly incised with a corresponding flatness within. Wherever the Egyptians practised the true bas-relief the sculpture is almost invariably in very low relief. The back view of the human figure is never represented in the sculptures excepting in the case of an enemy, and then rarely; the figure is generally represented in profile, and there are but few attempts at delineating the front view of the foot or of the face; however, whether the face be represented in front or side view, a profile eye is never found. The figures of the king in battle-pieces, and of the landed proprietor in domestic scenes, are always on a much larger scale than the other actors in the piece. Statues and reliefs were always painted, and when wall painting is employed it is always as a substitute for sculpture. There is no proper perspective, and certain conventionalities of color are employed. The Egyptians are represented with red and yellow complexions, red ochre for the men and yellow for the women. The hair of the king is frequently painted blue, but that of ordinary men black. In representing the various nations with whom Egypt had intercourse, the artists seem to have endeavored to imitate the complexions peculiar to each. Ammen-Ra, the chief divinity of Thebes, is always painted blue, and he is further distinguished by two high feathers which he wears in his cap. The inferior divinities are not uncommonly of the complexions of mortals. The sky or heavens are invariably indicated by a strip of blue coming downward at the lower side of each extremity, and occasionally having upon it a row of five-pointed stars. Water, seas and rivers are represented by zigzag lines of a blue or green color. Mountains have a yellow color, with red spots upon it. Egyptian art was at its highest during the period between the 4th and 6th dynasties, and notwithstanding its defects it was superior to that of Nineveh and Babylon. Gold and enamel jewelry with rich necklaces and pectorals of a very early period have come down to us. Artistic design was skilfully applied by the Egyptians to articles of furniture, ornament and articles of domestic use—mirrors, spoons, chairs, etc. Wood, ivory and various metals were used. The Phœnicians and Greeks spread these works along the Mediterranean littoral where they exerted a very great influence on design. (See ART; SCULPTURE). Consult Lepsius, 'Denkmäler' (1874); Perrot and Chipiez, 'History of Art in Ancient Egypt' (1883).

RUSSELL STURGIS.



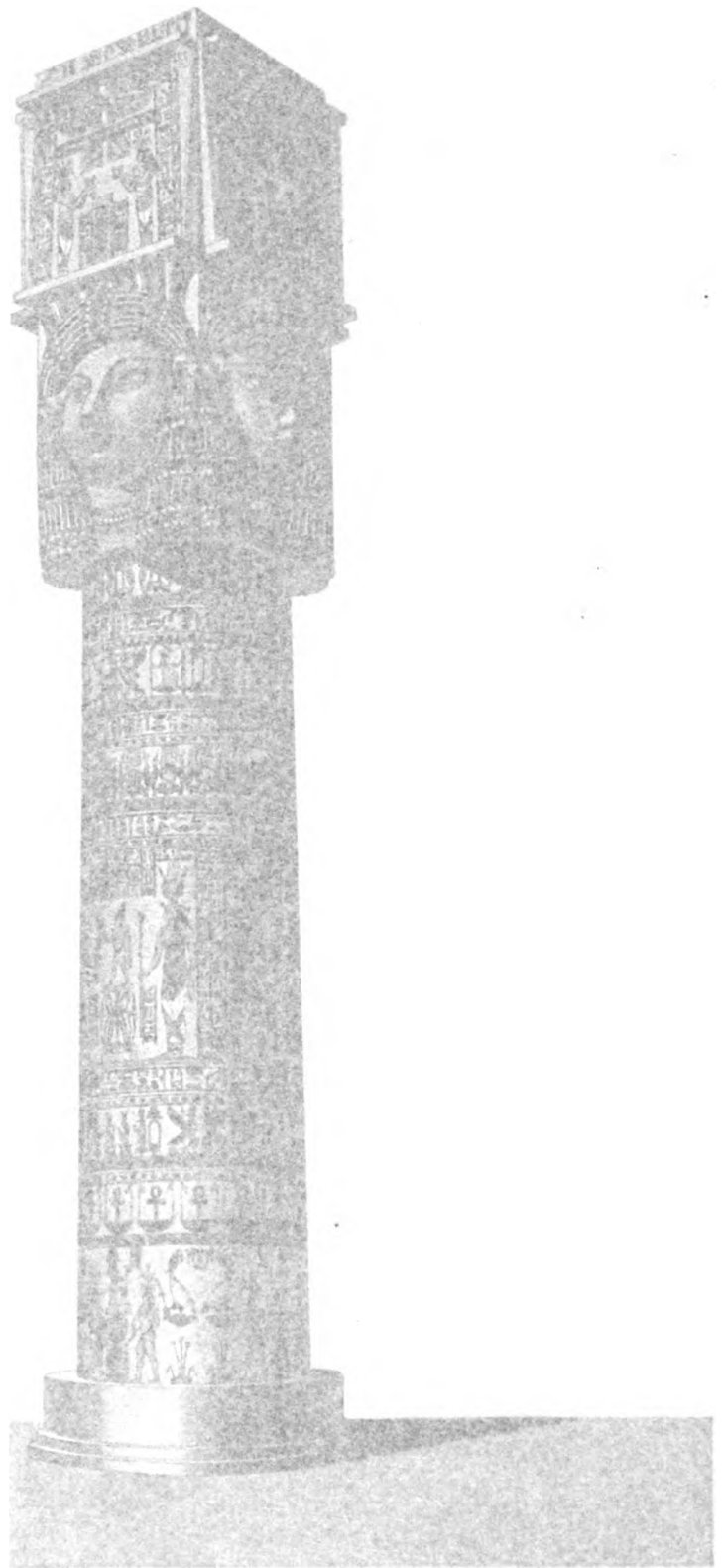

EGYPTIAN OBELISK, THEA...

1880





HATHORIC COLUMN, TEMPLE OF DENDERA  
(Restored)



**EGYPTIAN BEAN**, a name sometimes given to the bean-like fruits of the *Nelumbium speciosum*, the sacred lotus, found in Asia and Africa.

**EGYPTIAN BLUE**, a brilliant pigment consisting of the hydrated protoxide of copper mixed with a minute quantity of iron.

**EGYPTIAN LANGUAGE AND WRITING.** To formulate an opinion in regard to the group to which the ancient language of Egypt belonged, it is best to follow step by step the gradual process of interpretation and secondly the translation of the numerous texts existing in inscriptions and papyri. By so doing one is led to the conclusion that the language of old Egypt belonged to the Semitic family, an opinion objected to until quite recently. The first modern studies tending to elucidate the mysterious tongue locked up in the Egyptian hieroglyphics were those of the learned Jesuit Athanasius Kircher (1601-80), but they, like those of other savants of the 17th and 18th centuries, were without result until the discovery of a tablet inscribed in three languages furnished the key to the history of an ancient civilization, whose annals extended over 40 centuries. A French military officer, Captain M. Boussard, found in 1798 or 1799 in the fort of Saint Julien de Rosetta an inscription drawn up by the priests of Egypt gathered at Memphis, in honor of Ptolemy Epiphanes (196 B.C.). The first inscription was carved in hieroglyphics, the second in *demotic characters* and the third in Greek. The inscriptions were copied and copies sent to several academies. The Rosetta tablet came into the hands of the British in 1801 and now rests in the British Museum. The first Greek translation was that of Du Theil and Weston in 1801-02, and about the same time Akerblad, a Swedish Orientalist connected with the embassy at Paris, deciphered several demotic phrases, identifying the equivalents of the names of Alexander, Alexandria, Ptolemy and others, being guided principally by the position they occupied in the Greek text. Subsequently Thomas Young published in 1819 the result of his labors in this field, formulating some rudiments of an Egyptian vocabulary from the Rosetta Stone and from other monuments. Warburton, Barthelemy, Zœga and others indicated the possibility of the existence of a hieroglyphic alphabet. Finally Champollion the Younger, prepared by his studies of history and philology, brought an almost complete light to bear on the subject, revealing the contents of hieroglyphic writing on many inscriptions. His 'Précis du système hieroglyphique' was followed, after his death in 1832, by the publication of a grammar and dictionary of the Egyptian tongue. Lepsius, Birch, Rouge, Chabas and others continued the work but without success in establishing the grammatical structure of the works on a solid basis. Gaston Maspero and Revillout added considerably to the collection of translation, but the admirable scientific precision of the modern translations was first reached in 1880 when Louis Stern published his Coptic grammar, and when Erman published his in 1902. This last-named work is based on wide study of the linguistic variations during the time that the ancient Egyptian tongue was a living idiom. It shows the changes of different periods and permits that those who study

this old tongue may now do so with as great security as those who undertake the study of Latin or of Greek. The investigations of the German school, which counts illustrious members in England, Denmark, the United States, Italy and France, are published in the annals of the Berlin Academy of Sciences. From the most recent studies it appears that the ancient Egyptian belonged to the Semitic branch. Until recently and because of the biliteral roots of the Coptic, it was supposed that the Egyptian language should be classified with the three sub-families of the Hamite group previous to the formation of the Semitic, of which the triliteral root is characteristic. But it was shown that the biliteral roots of the Coptic had originated from triliteral roots of the early Egyptian and other similarities were shown which prove conclusively that ancient Egyptian belonged to the Semitic branch. The ancient language had four periods: (1) that of the Ancient Empire, employed until some centuries previous to our era; (2) colloquial Egyptian, employed by merchants and in social intercourse, and which existed from the 6th to the 17th or 18th dynasty; (3) the popular tongue from the 18th dynasty to the end of the period of Roman domination, and (4) the language of the country from the propagation of Christianity until it ceased to be spoken three centuries ago, except in the liturgy of the Coptic Christians.

Ancient Egyptian writing had three forms: (1) the *Hieroglyphic*, the most ancient, employed on inscriptions on temples, tombs, pillars and statues; (2) the *Hieratic*, the abbreviated form of the former. It was employed by the priests from the 4th to the 16th dynasty; (3) the *Demotic* or popular form, which began about the end of the 22d dynasty and consisted of conventional signs. The hieroglyphic writing was employed with small variation from the 4th dynasty until the 3d century of our era. The signs were employed in three ways—1st, representing in themselves an object, idea, a word or root; 2d, representing a syllable or part of a word; 3d, limiting the sense of a word already expressed by one or more signs. Phonograms were few, about 100 in all, of which 70 or 80 were in current use. The most important signs are those representing a single letter; in the Old Empire there were 24 of these. Signs representing two letters were about 50, and those which represented three letters were formed by combinations of this and the first group. Ideographic signs were represented by hieroglyphs symbolizing an idea, viz.: V a sceptre signified *prince or ruler*; ☾ the moon; ☼ the sun; an inclined wall represented the action of falling, etc., etc. Hieroglyphs were written horizontally or perpendicularly, reading in the direction in which the signs figuring birds were faced, which was generally from right to left of the reader, except in cases where the horizontal direction was changed to conform with the sides of a door, pylon, etc. To preserve a symmetrical appearance the scribes were accustomed to group the signs in squared areas and by adopting syllabic notation when the signs hindered such symmetrical disposition. Only the consonants were represented, thus adding materially to the difficulty of interpretation, which

is also complicated by the fantastic writing of various scribes and their errors. See **HIEROGLYPHICS; EGYPTIAN LITERATURE.**

**EGYPTIAN LITERATURE.** The advance that has been made in recent years in the decipherment of the ancient writings of the world enables us to deal in a very matter-of-fact way with the Egyptian inscriptions. Their chief mysteries are solved, their philosophy is almost fathomed, their general nature is understood. The story they have to tell is seldom startling to the modern mind. The world was younger when they were written. The heart of man was given to devious ways then, as now and in the days of Solomon,—that we can affirm full well; but his mind was simpler; apart from knowledge of men and the conduct of affairs, the educated Egyptian had no more subtlety than a modern boy of 15, or an intelligent English rustic of a century ago.

To the Egyptologist by profession the inscriptions have a wonderful charm. The writing itself in its leading form is the most attractive that has ever been seen. Long rows of clever little pictures of things in heaven and earth compose the sentences; every sign is a plaything, every group a pretty puzzle, and at present, almost every phase well understood brings a tiny addition to the sum of the world's knowledge. But these inscriptions, so rich in facts that concern the history of mankind and the progress of civilization, seldom possess any literary charm. If pretentious, as many of them are, they combine bald exaggeration with worn-out simile, in which ideas that may be poetical are heaped together in defiance of art. Such are the priestly laudations of the kings by whose favor the temples prospered. Take, for instance, the dating of a stela erected under Rameses II on the route to the Nubian gold mines. It runs:—

On the fourth day of the first month of the season of winter, in the third year of the Majesty of Horus, the Strong Bull, beloved of the Goddess of Truth, lord of the vulture and of the ureus diadems, protecting Egypt and restraining the barbarians, the Golden Horus, rich in years, great in victories, King of Upper Egypt and King of Lower Egypt, *Mighty in Truth of Ra, Chosen of Ra, the son of Ra, Rameses Beloved of Amen*, granting life for ever and ever, beloved of Amen Ra lord of the "Throne of the Two Lands" in Aft Egypt, appearing glorious on the throne of Horus among the living from day to day even as his father Ra; the good god, lord of the South Land, Him of Edfu Horus bright of plumage, the beautiful sparrow-hawk of electrum that hath protected Egypt with his wing, making a shade for men, fortress of strength and of victory; he who came forth terrible from the womb to take to himself his strength, to extend his borders, to whose body color was given of the strength of Mentu; the god Horus and the god Set. There was exultation in heaven on the day of his birth; the gods said, "We have begotten him"; the goddesses said, "He came forth from us to rule the kingdom of Ra"; Amen spake, "I am he who have made him, whereby I have set Truth in her place; the earth is established, heaven is well pleased, the gods are satisfied by reason of him." The Strong Bull against the vile Ethiopians, which uttereth his roaring against the land of the negroes while his hoofs trample the Troglodytes, his horn thrusteth at them; his spirit is mighty in Nubia and the terror of him reacheth to the land of the Kary; his name circuleteth in all lands because of the victory which his arms have won; at his name gold cometh forth from the mountain as at the name of his father, the god Horus of the land of Baka; beloved is he in the Lands of the South even as Horus at Meama, the god of the Land of Bahen, King of Upper and Lower Egypt, *Mighty in Truth of Ra, son of Ra, of his body, Lord of Diadems, Rameses Beloved of Amen*, giving life for ever and ever like his father Ra, day by day. [Revised from the German translation of Professor Erman.]

As Professor Erman has pointed out, the courtly scribe was most successful when tak-

ing his similes straight from nature, as in the following description, also of Rameses II:—

A victorious lion putting forth its claws while roaring loudly and uttering its voice in the Valley of the Gazelles. . . . A jaecal swift of foot seeking what it may find, going round the circuit of the land in one instant, his mighty will seizeth on his enemies like a flame catching the ki-ki plant with the storm behind it, like the strong flame which hath tasted the fire, destroying, until everything that is in it becometh ashes; a storm howling terribly on the sea, its waves like mountains, none can enter it, every one that is in it is engulfed in Duat.

Here and there among the hieroglyphic inscriptions are found memorials of the dead, in which the praises of the deceased are neatly strung together and balanced like beads in a necklace, and passages occur of picturesque narrative worthy to rank as literature of the olden time. We may quote in this connection from the biographical epitaph of Ameny, who was governor of a province in middle Egypt for 25 years during the long reign of Usertesen I (about 2716 B.C.). This inscription not only recounts the achievements of Ameny and the royal favor which was shown him, but also tells us in detail of the capacity, goodness, charm, discretion and insight by which he attached to himself the love and respect of the whole court, and of the people over whom he ruled and for whose well-being he cared. Ameny says:—

I was a professor of favor, abounding in love, a ruler who loved his city. Moreover I passed years as ruler in the Oryx nome. All the works of the house of the King came into my hand. Behold, the superintendent of the gangs of the domains of the herdsmen of the Oryx nome gave me 3,000 bulls of their draught stock. I was praised for it in the house of the King each year of stock-taking. I rendered all their works to the King's house: there were no arrears to me in any of his offices.

The entire Oryx nome served me in numerous attendances. There was not the daughter of a poor man that I wronged, nor a widow that I oppressed. There was not a farmer that I chastised, not a herdsman whom I drove away, not a foreman of five whose men I took away for the works. There was not a pauper around me, there was not a hungry man of my time. When there came years of famine, I arose and ploughed all the fields of the Oryx nome to its boundary south and north, giving life to its inhabitants, making its provisions. There was not a hungry man in it. I gave to the widow as to her that possessed a husband, and I favored not the elder above the younger in all that I gave. Thereafter great rises of the Nile took place, producing wheat and barley, and producing all things abundantly, but I did not exact the arrears of farming.

Elsewhere in his tomb there are long lists of the virtues of Amenemhat, and from these the following may be selected both on account of picturesqueness of expression and the appreciation of fine character which they display:—

Superintendent of all things which heaven gives and earth produces, overseer of horns, hoofs, feathers, and shells.

Master of the art of causing writing to speak.

Careassing of heart to all people, making to prosper the timid man, hospitable to all, escorting [travelers] up and down the river. . . . Knowing how to aid, arriving at his time of need; free of planning evil, without greediness in his body, speaking words of truth. . . . Unique as a mighty hunter, the abode of the heart of the King.

Speaking the right when he judges between suitors, clear of speaking fraud, knowing how to proceed in the council of the elders, finding the knot in the skein. . . . Great of favors in the house of the King, contenting the heart on the day of making division, careful of his goings to his equals, gaining reverence on the day of weighing words, beloved of the officials of the palace.

The cursive forms of writing—hieratic from the earliest times, demotic in the latest—were those in which records were committed to papyrus. This material has preserved to us documents of every kind, from letters and ledgers to works of religion and philosophy. To these, again, "literature" is a term rarely

to be applied; yet the tales and poetry occasionally met with on papyri are perhaps the most pleasing of all the productions of the Egyptian scribe.

It must be confessed that the knowledge of writing in Egypt led to a kind of primitive pedantry, and a taste for unnatural and to us childish formality; the free play and naivete of the story-teller is too often choked, and the art of literary finish was little understood. Simplicity and truth to nature alone gave lasting charm, for though adornment was often attempted, their rude arts of literary embellishment were seldom otherwise than clumsily employed.

A word should be said about the strange condition in which most of the literary texts have come down to us. It is rarely that monumental inscriptions contain serious blunders of orthography; the peculiarities of late archaistic inscriptions, which sometimes produce a kind of "dog Egyptian" can hardly be considered as blunders, for the scribe knew what meaning he intended to convey. But it is otherwise with copies of literary works on papyrus. Sometimes these were the productions of schoolboys copying from dictation as an exercise in the writing school, and the blank edges of these papyri are often decorated with essays at executing the more difficult signs. The master of the school would seem not to have cared what nonsense was produced by the misunderstanding of his dictation, so long as the signs were well formed. The composition of new works on the model of the old, and the accurate understanding of the ancient works, were taught in a very different school, and few indeed attained to skill in them. The boys turned out of the writing school would read and write a little; the clever ones would keep accounts, write letters, make out reports as clerks in the government service, and might ultimately acquire considerable proficiency in this kind of work. Apparently men of the official class sometimes amused themselves with puzzling over an ill written copy of some ancient tale, and with trying to copy portions of it. The work, however, was beyond them; they were attracted by it, they revered the compilations of an elder age and those which were "written by the finger of Thoth himself"; but the science of language was unborn, and there was little or no systematic instruction given in the principles of the ancient grammar and vocabulary. Those who desired to attain eminence in scholarship after they had passed through the writing school had to go to Heliopolis, Hermopolis or wherever the principal university of the time might be, and there sit at the feet of priestly professors; who we fancy were revered as demigods, and who in mysterious fashion and with niggardly hand imparted scraps of knowledge to their eager pupils. Those endowed with special talents might after almost lifelong study become proficient in the ancient language. Would that we might one day discover the hoard of rolls of such a copyist and writer!

There must have been a large class of hack-copyists practised in forming characters both uncial and cursive. Sometimes their copies of religious works are models of deft writing, the embellishments of artist and colorist being added to those of the calligrapher; the magnifi-

cent rolls of the 'Book of the Dead' in the British Museum and elsewhere are the admiration of all beholders. Such manuscripts satisfy the eye, and apparently neither the multitude in Egypt nor even the priestly royal undertakers questioned their efficacy in the tomb. Yet are they very apples of Sodom to the hieroglyphic scholar, fair without but ashes within. On comparing different copies of the same text, he sees in almost every line omissions, perversions, corruptions, until he turns away baffled and disgusted. Only here and there is the text practically certain, and even then there are probably grammatical blunders in every copy. Nor is it only in the later papyri that these blunders are met with. The hieroglyphic system of writing, especially in its cursive forms, lends itself very readily to perversion by ignorant and inattentive copyists; and even monumental inscriptions, so long as they are mere copies, are usually corrupted. The most ridiculous perversions of all date from the Rameses epoch when the dim past had lost its charm, for the glories of the 18th dynasty were still fresh, while new impulses and foreign influence had broken down adherence to tradition and isolation.

In the 8th century B.C. the new and the old were definitely parted, to the advantage of each. On the one hand the transactions of ordinary life were more easily registered in the cursive demotic script, while on the other the sacred writings were more thoroughly investigated and brought into order by the priests. Hence, in spite of absurdities that had irremediably crept in, the archaistic texts copied in the 26th dynasty are more intelligible than the same class of work on the 19th and 20th dynasties.

In reading translations from Egyptian, it must be remembered that uncertainty still remains concerning the meanings of multitudes of words and phrases. Every year witnesses a great advance in accuracy of rendering; but the translation even of an easy text still requires here and there some close and careful guesswork to supply the connecting links of passages or words that are thoroughly understood, or the resort to some conventional rendering that has become current for certain ill understood but frequently recurring phrases. The Egyptologist is now to a great extent himself aware whether the ground on which he is treading is firm or treacherous, and it seems desirable to make a rule of either giving the public only what can be warranted as sound translation, or else of warning them where accuracy is doubtful. A few years ago such a course would have curtailed the area for selection to a few of the simplest stories and historical inscriptions; but now we can range over almost the whole field of Egyptian writing, and gather from any part of it warranted samples to set before the reading public. The labor, however, involved in producing satisfactory translations for publication, not mere hasty readings which may give something of the sense, is very great; and at present few texts have been well rendered.

We may now sketch briefly the history of Egyptian literature, dealing with the subject in periods:

1. The Ancient Kingdom, About 4400 B.C.—3000 B.C.—The earlier historic period—from the 1st dynasty to the 3d, about 3766 B.C.

—has left no inscriptions to any extent. Some portions of the 'Book of the Dead' (q.v.) profess to date from these or earlier times, and probably much of the religious literature is of extremely ancient origin. The first book of 'Proverbs' in the Prisse Papyrus is attributed by its writer to the end of the 3d dynasty (about 3766 B.C.). From the 4th dynasty to the end of the 6th (3100 B.C.) the number of the inscriptions increases; tablets set up to the kings of the 4th dynasty in memory of warlike raids are found in the peninsula of Sinai, and funerary inscriptions abound. The pyramids raised at the end of the 5th and during the 6th dynasties are found to contain interminable religious inscriptions, forming almost complete rituals for the deceased kings. Professor Maspero, who has published these texts, states that they "contain much verbiage, many pious platitudes, many obscure allusions to the affairs of the other world, and among all this rubbish some passages full of movement and wild energy, in which poetical inspiration and religious emotion are still discernible through the veil of mythological expressions." Of the funerary and biographical inscriptions the most remarkable is that of Una, an official of King Mer-en-ra (6th dynasty).

Another, later but hardly less important, is on the façade of the tomb of Hehrhuf, at Asswan, and recounts the expeditions into Ethiopia and the southern oasis which this resourceful man carried through successfully. In Hehrhuf's later life he delighted a boy king of Egypt by bringing back for him from one of his raids a grotesque dwarf dancer of exceptional skill; the young Pharaoh sent him a long letter on the subject, which was copied in full on the tomb as an addition to the other records there. It is to the 5th dynasty also that the second collection of 'Proverbs' in the Prisse Papyrus is dated. The 7th and 8th dynasties have left us practically no records of any kind.

**2. The Middle Kingdom, 3000-1600 B.C.—**The Middle Kingdom from the 9th to the 17th dynasty shows a great literary development. Historical records of some length are not uncommon. The funerary inscriptions descriptive of character and achievement are often remarkable.

Many papyri of this period have survived: the Prisse Papyrus of 'Proverbs,' a papyrus discovered by Mr. Flinders Petrie with the 'Hymn to Useratesen III,' papyrus at Berlin containing a dialogue between a man and his soul, the 'Story of Sanehat,' the 'Story of the Sekhti,' and a very remarkable fragment of another story; besides the 'Westcar Papyrus of Tales' and at Saint Petersburg the 'Shipwrecked Sailor.' The productions of this period were copied in later times; the royal 'Teaching of Amenemhat' and the worldly 'Teaching of Dauf' as to the desirability of a scribe's career above any other trade or profession exist only in late copies. Portions of the 'Book of the Dead' are found inscribed on tombs and sarcophagi.

**3. The New Kingdom, etc.—**From the New Kingdom, 1600-700 B.C., we have the 'Maxims of Any,' spoken to his son Khonsu Hetep, numerous hymns to the gods, including that of King Akhenaten (Amenhotep IV) to the disc of the sun, and hymns to Amen Ra. Inscrip-

tions of every kind, historical, mythological and funereal, abound. The historical inscription of Piankhi is of very late date. On papyri are the stories of 'The Two Brothers,' of 'The Taking of Joppa,' of the 'Doomed Prince.'

From the Saite period (26th dynasty, 160 B.C.) and later, there is little worthy of record in hieroglyphics; the inscriptions follow ancient models. In demotic we have the 'Story of Setna,' a papyrus of moralities, a chronicle somewhat falsified, a harper's song, a philosophical dialogue between a cat and a jackal and others.

Here we might end. Greek authors in Egypt were many; some were native, some of foreign birth or extraction, but they all belong to a different world from the ancient Egyptian. With the adaptation of the Greek alphabet to the spelling of the native dialects, Egyptian came again to the front in Coptic, the language of Christian Egypt. Coptic literature, if such it may be called, was almost entirely produced in Egyptian monasteries and intended for edification. Let us hope that it served its end in its day. To us the dull, extravagant and fantastic 'Acts of the Saints,' of which its original works chiefly consist, are tedious and ridiculous except for the linguist or the Church historian. They certainly display the adjustment of the ancient Egyptian mind to new conditions of life and belief.

**Some Modern Texts and Translations.—**The bulk of the Egyptian literature has been preserved in papyri, nearly all of which are scattered in the various museums of Europe. Nine papyri out of 10 contain the religious books and rituals which were placed with the mummies in the coffins or in the sepulchral chambers. The most famous of them is the 'Book of the Dead,' a compilation of prayers and magical incantations intended to ensure the security of the soul in the other world, and to serve it as a sort of password in the travels it was compelled to undertake before reaching the Hall of Judgment and the Elysium Fields. Several copies of this book have been reproduced in facsimile by Lepsius ('Das Todtenbuch der alten Ägypter,' Berlin 1842) and by E. de Rougé ('Rituel funéraire des Anciens Égyptiens,' Paris 1861-64) but the standard edition is that projected by the International Congress of Orientalists in London (1874) and executed in part by Naville in 'Das thebanische Todtenbuch der XVIII bis XX Dynastie' (Berlin 1886). It gives, however, only those chapters which are to be found in the manuscripts of the Theban period. Translations of the whole book exist in English, prepared by Birch (in Bunsen's 'Egypt's Place in Universal History,' Vol. V, 1866) and by Le Page-Renouf in 'Proceedings of the Society of Biblical Archaeology.' Rituals proper, that is collections of the ceremonies of prayers performed in the temples and tombs—are very numerous; such are the ritual for the cult of the Theban Amon. The *Opening of the Mouth* and the other rites performed on the day of burial have been preserved to us in the pyramids of the 5th and 6th dynasties and in the private and royal vaults of the Theban cemeteries. The texts in the pyramids have been collected and translated by Maspero and those of the Theban hypogees by Schiaparelli ('Il libro dei Funerali degli Antichi Egiziani,'



Rome 1880-90). Books of magic abound, though they are not as numerous as the ritualistic or religious works. Most of them are unpublished as yet, but the translation of Chabas ('Le papyrus magique Harris,' Chalons-sur-Saone 1861); Pleyte ('Etude sur un rouleau magique, etc.')

and Lefebvre ('Un chapitre de la chronique solaire') give a sufficient idea of the ways in which Pharaoh's magicians were wont to conjure the demons. That they were sometimes prosecuted as adepts in the black art is proved by the proceedings of a trial for high treason at Thebes during the reign of Rameses III. Magicians often acted as physicians or surgeons, and no remedy could be properly applied without their help. About 20 treatises on medicine are known to exist, of which a few have been published ('Papyrus médical de Berlin'). Ebers studied and published comments upon portions of his papyrus which relate to the diseases of the eye. No papyrus treating of astronomy has yet been discovered, but the calendars, zodiacs, astronomical and astrological tables which abound on the walls of temples and tombs at Ombos, Esneh, Edfu, Denderah the Ramesseum, the Memnonium of Abydos and others, furnish a large quantity of material. Three mathematical papyri have been found, one of Roman times and one from the 12th dynasty and one at Thebes. There are several works on philosophy, which was limited to a rendition of moral precepts and aphorisms on the conduct of life. Some are very ancient—the 'Papyrus Prisse' seems to have been written in the 12th dynasty and has been called "the oldest book in the world." Poems and songs are by no means rare in the manuscripts. The remains of two collections of love-songs have been studied by Maspero ('Etudes Egyptiennes,' Vol. 1) and the poem on the battle of Kadesh, in which Rameses II is made to describe how he fought against the Hittites, is widely known. There was a whole literature of stories akin to the 'Arabian Nights.' De Rougé discovered the first of them in 1852 and entitled it 'A Tale of Two Brothers' and since then about 20 have been published; the most curious among them are the 'Tale of the Wicked Mariner' (Golenischeff, 'Sur un ancien conte égyptien,' Leipzig 1881) and the 'Tale of Khonfou and the Magicians' (Erman, 'Der Papyrus Westcor,' Berlin 1891). They have been collected by Maspero in his 'Contes populaires de l'ancienne Égypte' (2d ed., Paris 1890). Even fables were current in Egypt which the Greeks attributed to Æsop; the fable of 'The Lion and the Mouse' (Lauth, 'Their nabel in Ägypten,' Munich 1868) and 'Dispute of the Members and the Stomach' (Maspero, op. cit., Vol. 1). Private letters have come down, many of them sealed and unopened, others preserved in anthologies, where teachers of the 19th and 20th dynasties had inserted specimens of descriptions and poetical epistles, official reports on administrative subjects, as models of elegant style for the young scribes, their pupils. Several of these have been published by the trustees of the British Museum in the first volume of the 'Select Papyri' (London 1841-44). The Old Egyptian language has been the subject of continuous research and there are many excellent grammars but lexicography is not so well advanced. For the constant progress in

this field of uncovering the ancient literature of Egypt consult the notes, pamphlets, papers, etc., inserted in the various journals of Europe and America. Consult also 'Transactions and Proceedings' of the Society of Biblical Archæology and 'Memoirs of the Egyptian Exploration Fund' in England; the 'Zeitschrift der Deutschen Morgenländischen Gesellschaft' and the 'Zeitschrift für Ägyptische Sprache und Alterthumskunde,' in Germany; and the *Journal Asiatique, Revue de l'Histoire des Religions*, the *Revue Egyptologique*, in France; (Prince) Ibrahim-Hilmy, 'The Literature of Egypt and The Soudan' (2 vols., London 1886-88). See HIEROGLYPHICS.

SAMUEL AUGUSTUS BINION,

Author of '*Ancient Egypt or Mizraim.*'

**EGYPTIAN MUSIC.** Our knowledge of the music of ancient Egypt is very meagre. We have short accounts of it in Greek authors and we find specimens of their musical instruments and there have survived numerous illustrations of others, together with scenes representing the singing of odes to the gods, or their heroes, funeral dirges, and we know that musicians and dancers formed a part of all entertainments. In general their instruments are of the same character as those of the Hebrews and Assyrians, from which we infer that their music was of the same general type as that of these neighboring civilized peoples. Their first music was merely an accompaniment to the dance, as we find representations of singers clapping their hands in rhythm to the motions of the dance. Vocal music was made up of solos and choruses. Women often sang without musical accompaniment, but it appears that men rarely did so. Many songs have been preserved, one of the oldest being that of the oxen threshing out the corn. The Egyptians had no clear or fixed ideas of harmony and possessed no system of notation although they had many treatises on music. The harp, lyre, flute, trumpet, drum, cymbals and tambourine were their principal instruments. We find notices of the harp prior to 3000 B.C. At first it had but 7 strings increasing gradually to 22. The strings were of catgut. It had no pedals and could be played in but one key. The lyre was also a popular instrument of from 6 to 20 strings. Flutes were in use at an early period. About 500 B.C. the *te-bouni*, a kind of banjo, came into use. It generally had but one string, although some specimens have two or three. A shoulder harp was also in vogue about this time; it was played when resting on the shoulder. It was a medium between the harp and guitar. All these instruments underwent considerable development in the course of time and there were also a number of derived instruments. Both women and men played on these, although certain instruments appear to have been peculiar to each sex. Consult Engel, 'Music of the Ancients' (London 1864); Mathews, 'Popular History of Music' (Chicago 1894); Smith, 'World's Earliest Music' (London 1904).

**EGYPTIAN RELIGION AND SOCIOLOGY.** Religion.—No satisfactory treatment of ancient Egyptian religion has appeared, though the subject was one of the first to awaken interest in modern times. The names

of the deities of the Pantheon are well known and their general characteristics are sufficiently defined, but the gradations between them and the conceptions which gave them force are obscured not only by the most curious inconsistencies but by the fog of mythology which is for the most part unknown to us. Religious conceptions existed during all periods, but never a religion in any true sense. It is plain enough that the differences in religious belief and practice corresponded to the primitive condition of the land, each district having its chief object of veneration. It was a condition of Henotheism out of which, in consequence of the closer contact produced by the union of the *nomoi* under a central government, there grew up a system of national polytheism in which the principal god of the capital gained pre-eminence. The original deities were objects of nature, but their development was various in the different *nomoi*. Only at a later date did gods appear who represented abstract or cosmogonical ideas. When intimate association occurred there was a resultant confusion of attributes and names. The hegemony of the god of the capital contained in itself the motives of Monotheism, but there is no indication that Monotheism was the original form of the Egyptian religion or that the people ever advanced to it, in spite of such phrases as "the only god" and the like. When carefully examined these expressions are found to refer to the deity held in special reverence in a particular locality, the "city god" or the leader of the local triad or ennead. Endowed temples and independent priests of separate deities prove that a determined resistance was made to any attempt to introduce monotheism, such as is actually seen in the case of Amenophis IV. Ptah was the god of Memphis; Neith, the warlike goddess of Libyan Sais; Chnum of Elephantine was the deity of the cataract regions; Nechebt was goddess of the south in general; Min was the desert god; Osiris of Abydon supplanted an earlier deity; Amon of Thebes, Anubis of Tycopolis, Tum of Heliopolis, Bast of Bubastis, Sebek of the Fayum, Hathor of Denderah, Horus of Edfu, Thoth of Hermopolis, Mont of Hermonthes are examples of the local gods.

The forms of many of the deities are extremely grotesque. It may be a human or animal shape but frequently it is a mixture of the two; the human trunk being surmounted by an animal head. Thus Ptah appears as the Apis-Bull; Hapi, Amon and Chnum as rams; Sebek as a crocodile-headed man; Nechebt as a serpent; Mut as a vulture; Anubis as a jackal-headed man; Bast as a cat-headed woman; Sechmet and Tefnut as lion-headed; Hathor as a cow; Horus as a hawk, or hawk-headed man; Thoth as an ibis. The Phoenix is possibly derived from Benu of Hieropolis, which appears as a heron.

In various periods of the history certain deities appear as deifications of the powers of nature: Ra, the sun, the ruler of the world, having his sanctuary at Heliopolis, was even in prehistoric times conceived as a person; Horus, the bringer of light, is represented in conflict with Set, the god of darkness; Ra-Harmachis was the rising sun; Ra-Tum the sun at evening. Thoth was also worshipped as the moon. The number of mythological beings, such as Nun, the original ocean, out of which Ra proceeded,

is beyond number. Mat, the goddess of truth, represents a large class which symbolizes abstract notions. Deities are also portrayed in pairs, such as Aeb, god of earth, and Hut, goddess of Heaven, Shu and Tefnut, Osiris and Isis. In these pairs is seen the family relation which is carried out in numerous ways, not without great confusion. Much of the religion has its explanation only in connection with the future life. When the soul or "double" (*ka*) left the body, the latter was preserved with extreme care and deposited in a secure tomb, for the personal existence of the disembodied spirit depended upon the absolute preservation of the mummy. The future of the individual was determined by a judgment which is represented as weighing of the heart by Horus, who counterbalances it with the symbol of the truth. Mat, the goddess of truth, watches the operation, and Thoth, scribe of the gods, registers the result. In the earliest periods specific beliefs as to their nature, qualities and powers, clustered about the individual deities, but these did not become a true mythology till the amalgamation of variant views under the influence of the national union of the *nomoi*. The confusion which resulted led to attempts at harmony. But little is known of this mass of mythology, which must have been very extensive if one is to judge by the allusions abounding in every religious text.

The ancient Egyptian religion was, therefore, a kind of philosophical pantheism, the various attributes of the deity being divided among the different gods of the Pantheon. Unlike the Greek, where a god was honored in a separate temple, each Egyptian divinity was accompanied by a *paut*, or "company" of companion-gods.

A few foreign deities became at the close of the 18th dynasty engrafted upon the religious system— as *Bar*, Baal; *Ashiarata*, Ashtaroth; *Anta*, Anaitis; *Ken*, Kiun; *Reshpu*, Reseph; *Set*, or Sutekh, sometimes identified with Baal. All the gods had human passions and affections, and their mode of action was material; they walked on earth, or sailed through ethereal space in boats. First among the deities comes Ptah, the opener, represented as the creator of the world, the sun and moon, out of chaos (*ha*) or matter, to whom belong Sekhet, "the lioness" and Bast, Bubastis, lion-headed goddesses presiding over fire, and Nefer-Tum, his son, a god wearing a lotus on his head. Next in the cosmic order is Chnum— worshipped at Elephantine— the ram-headed god of the liquid element, who also created the matter of which the gods were made; and connected with him are the goddesses Heka the Frog, or "primeval formation," Sati, or "sunbeam" and Anuka, alluding to the genesis of the cosmos. The Theban triad comprised Amen-ra, "the hidden" power of the "sun," the Jupiter; *Mut*, the "Mother" goddess of "Matter" the Juno; *Nit*, the "Shuttle," the Minerva; and *Khons*, "Force" is Hercules, a lunar type. A subordinate type of Amon is Khem or Amsu, "the enshrined," who, as *Harnekkht*, or Powerful Horus, unites beginning and end, or cause and effect.

A great variety of abstract principles and even animals and vegetables were, however, worshipped by the multitude, though the doctrine of one God was privately taught by the priests to a select few. Many of the ani-

mals, birds and reptiles were held sacred by the Ancient Egyptians; whoever killed a sacred animal, an ibis or a hawk, was put to death. If a cat died a natural death every person in the house shaved his eyebrows; if a dog died, the whole body and the head were shaved. The cats were sacred to the goddess Bast and were buried at Bubastis and the dogs in the vaults of their own cities, field-mice and hawks at Buto, the ibis at Hermopolis and other animals where they were found lying. Of all animals the sacred bull, Apis, was the most revered. His chief temple was at Memphis. The cow, being sacred to Isis, was thrown into the Nile, which was considered sacred; and the Apis bull was buried in the Serapeum near Memphis.

Of the doctrines of the Egyptian religion little is accurately known. The existence of the spirit after death was believed and a future state of rewards and punishments inculcated, in which the good dwelt with the gods, while the wicked were consigned to fiery torments amid perpetual darkness. It was believed that after the lapse of ages the spirit would return to the body, which was therefore carefully embalmed. See BOOK OF THE DEAD; EMBALMING; MOHAMMEDANISM; IDOLATRY; PANTHEISM.

**Social Organization, Manners and Customs.**—The monuments are fuller than the enumeration of Herodotus and Diodorus, who name seven and five classes respectively. Herodotus gives priests, warriors, cowherds, swineherds, tradesmen, interpreters and boatmen; Diodorus, priests, warriors, husbandmen, shepherds and artisans. All these existed, but the enumeration is defective. True caste was unknown. The population was divided into two great parts—nobles and slaves—while the middle class has left its traces from the Middle Empire onward. The upper class included royalty and those in the service of the state or religion, a ruling class, far removed from the slave population, foreign and native. They formed the backbone of the state, filled all the higher offices and were obeyed by all their social inferiors. At the head of the government stood Pharaoh, "King of the Upper and Lower Egypt, son of Ra, eternal." Rameses II is bombastically called "Horus, the mighty bull, beloved of the Goddess of Truth, protector of Egypt, subduer of barbarians, rich in years, great in victory, chosen of Ra, Rameses, beloved of Ra." Similarly the queen is called "the consort of the God, mother of the God, the great consort of the king"—god and king being interchangeable terms. She was usually of royal blood, often own sister of the king, his equal in birth and place—"Mistress of the House." Crown prince and princes came next in order. The upper classes consisted of "the nearest friend" of the king and friends of various grades, generals, high priests, officers, physicians, overseers, district chiefs, judges, keeper of the seal, master builders, treasurers, fan-bearers, scribes and others. Officialdom ramified in numberless class gradations, whether the order was priestly, military, literary, architectural or agricultural. Advancement went by royal or other favor. The middle class remained in the background and is less known because its members could not, like kings and nobles, erect those enduring tombs from which our knowledge of the times is obtained. After the removal of the necropolis from Memphis to Abydos during

the Middle Empire and owing to the increasing practice of erecting memorial stelae, the monuments of untitled persons begin to appear, giving a conception of their number and position. They possessed households similar to those of officials and in many ways appear to have been their equals. They were merchants, traders, artisans, free workmen, weavers, potters, carpenters, joiners, smiths, etc. The lowest class was composed of the slaves, native or taken in war, who were hewers of wood and drawers of water, performing all menial offices. They were mere chattels, belonging to temple, necropolis, or landed estate and were often organized as a part of the military establishment. Closely allied to them were the shepherds, the pariahs of Egyptian society.

Agriculture, manufacture and trade were carried on in Egypt in the very earliest days. Upon the ancient monuments we find representations of the mechanical arts, where we see the blow-pipe, bellows, siphons, press, balance, lever, saw, adze, chisel, forceps, syringe, harpoon, razors; we have also glazed pottery, the potter's wheel and the kiln; and dated specimens of glass of the time of (Thothmes III, 1445 B.C.). Gold-beating, damascening, engraving, casting, inlaying, enameling, wire drawing and other processes were practised. Weapons and other instruments of war, shields, cuirasses of quilted leather, helmets, spears, clubs, maces, daggers, bows, battle-axes, pole-axes, hatchets and falchions are shown. The testudo, ladders, torches and lanterns were also in use. In agriculture the plow, hoe, sickle and other implements were employed. The processes of growing and preparing flax and making it into thread, string, ropes and cloth, as well as the looms employed, are all depicted. Mats and baskets were beautifully made, either of the halfa grass or palm leaves, or of the outer rind of the papyrus plant, which was used in making paper. Coffins or wooden sarcophagi were chiefly of sycamore or cedar, covered with stucco and richly painted. The ordinary boats of the Nile were planks of the acacia and had two rudders or large oars, with a sail of cloth frequently painted or worked in colored patterns. Many of the vessels of burden were of great size. The boats made of papyrus were mostly punts for fishing, or for gliding through the canals of the Delta. Implements for painting ladles, bells, crucibles and surgical instruments have also been found. The commerce of the Egyptians with neighboring nations enriched the country with slaves, cattle, gems, metals, rare animals and objects of curiosity. The Egyptians expended enormous wealth on the tombs and furniture of the dead, and the paintings acquaint us fully with the various ceremonies followed. In embalming they excelled. Each administrative department had its own troop of laborers under its own overseer, who kept minute tally of work performed, rations distributed and of absentees. The troop, not the individual, was the unit. All artisans as well as the slaves were regarded superciliously by the scribes and held in lower repute than the agriculturists, though the products of their skill still command admiration. Weavers working with papyrus reeds or with linen thread, produced baskets, boats, mats, or the finest linen cloths; joiners though handicapped by lack of good raw material, nevertheless produced creditable work

by the use of instruments most simple in their character. Potters through all periods reproduced patterns tenaciously and with little variation, but atoned for the rudeness of much of their work by the fineness of their products in faience, the glazing of stone objects being especially noteworthy. Metal workers used gold, silver, bronze, iron and tin, the source whence tin was derived being problematical. A bronze is mentioned which was an alloy of six metals. Objects in bronze and iron have been found among the remains of the Old Empire, though the earliest bronze statue is one of Rameses II. The sources of most metals were the mines of Nubia and Sinai. In value silver exceeded gold and a mixture of the two is frequently mentioned. The processes of agriculture are well portrayed on the walls of the tombs. The plow was simply a sharpened stick dragged through the ground by oxen; the hoe a broad blade fastened to a handle, a second cord midway of each preventing too great a strain. The seed once scattered was trampled in by animals. Harvesting was done by a short sickle; the grain was carried in sheaves to the threshing floor, where the hoofs of cattle performed the required labor. Winnowing was done with shovel and wind and the grain was stored in conical receptacles open at the top, to which the bearers mounted on ladders. Supplementary irrigation was by a well sweep similar to the modern *shadouf*. These labors were so essential a part of Egyptian life that the future life was portrayed under exactly the same circumstances, happiness consisting essentially in the degree in which personal performance could be avoided. Cattle of all sorts, asses, sheep, pigs and goats existed in great herds and were tended by slaves and peasants whose occupations in marshy districts so far removed them from civilization that they were regarded with detestation. Their disrepute is the more remarkable in view of the evident pride with which landed proprietors enumerated their flocks.

The schools, "bookhouse" or "house of instruction" presided over by a scribe, was an institution of the Old Empire, which received all classes alike and prepared them for the technical education of the special bureau. In the New Empire both branches were combined in the departmental schools. Orthography, calligraphy, style and the formulæ of etiquette comprised the known curriculum; the rest was learned by practice. Many corrected school exercises have survived, containing various specimens of literature; tales, religious and magical texts, poems, codes of rules, or "instruction" of ancient sages for the proper regulation of daily life and statements of the unlovely condition of soldiers and laborers as contrasted with the beauty of the scribe's life, at once inciting to industry on the part of the pupil and to profound respect for the teacher. These papyri are of great value in affording a knowledge of orthography, language and literature. The tombs of the Old and Middle Empires represent the various operations of large landed estates in all their complexity. Such private ownership of the soil, of large tracts and even of whole villages, seems to have been a survival from the time when the princes of the nomor were at the head of the independent districts

which collectively constituted Egypt. A decided change is seen in the New Empire when the title to all land except that attached to temples was vested in the king and when it was worked for the state by slaves or let out at an annual rate per cent. The change came about during the Hyksos period or in the transition to the revived native dynasties. The biblical account of Joseph is of interest in this connection. The dwellings of the common people probably resembled those of the *fellahin* of to-day, being mud hovels, whose destruction accounts for the formation of the tells which mark city sites. The dwellings of nobles and kings were more pretentious, but no remains have survived. The only models by which to judge are some ancient sarcophagi of house-like form and some mural representations. Record has survived of a palace which stood 300 cubits square.

**Family Life.**—The position occupied by woman was quite extraordinary. In the household there was generally only one *wife*, though there might be several concubines or female slaves. Actual polygamy was infrequent, though the royal harem often contained 200 women. Private persons also maintained harems, the number of inmates depending on the financial ability of the individual. Inheritance and genealogy were reckoned by the mother, not the father, and while a man's possessions might descend to his sons, the line might also pass through the daughter to her sons. Sometimes marriages were contracted upon these considerations. It was a father's ambition to hand down his official position to his sons, and the title of "hereditary prince" is often met with. The practice of marriage with a sister is met with in early periods, but under the Ptolemies it was quite the rule, and the marriage contracts specified the amounts which the husband engaged to give annually to his wife for family purposes.

**Costume.**—There is a constant development observable in the dress of the upper classes. Royalty set the fashions, and they were followed at intervals by those standing on the various social levels. There was a distinction between king and noble, and between noble and plebeian. The simple apron bound about the loins was always the essential garment. To this the king added a lion's tail, and the noble a panther's skin during the period of the Old Empire. During the Middle Empire the apron took a pointed triangular shape and became longer; next comes a double apron, a short one beneath, opaque, and a long and transparent one outside. The priest continued to wear the short apron, however, while the king had advanced to a mode of dress which covered the whole body and was complex in structure. That which before was holiday attire became the garb of every day. The dress of women was more uniform. It consisted at first of a close-fitting garment which extended from the breasts to the ankles, and was fastened by straps over the shoulders. Only in the latest periods were sleeved or sleeveless mantles worn. Transparent cloth was used for female wear, as for the outer apron of males, but without the inner garment. The dress of peasants consisted simply of the apron, which in some cases amounted only to a band with pendant ends. These simple articles were made of papyrus mats, leather or cloth.

The hair was worn short, but the shaving of the head does not appear to have been practised daily. Wigs of various forms and sizes were used as ceremonial head coverings. Specimens of them are not infrequent. Natural beards were not worn except by shepherds and similar persons but an artificial "imperial" beard was one of the marks of royalty and divinity in the tomb representations. Sandals of various sorts completed the costume. Egyptian garments of the better class were of linen, wool being regarded as filthy. The food of the lower classes consisted largely of bread and vegetables. The principal vegetables were kidney beans, lentils, turnips, radishes, carrots and spinach. Milk and cheese were also common articles of food. Pomegranates, dates, figs and grapes were plentiful. The flesh of the goat, ox, gazelle, antelope and other animals formed part of the diet of the middle classes, the flesh of the hog was not in use, this animal being considered unclean. Geese, ducks, turtle doves and hens were abundant and even to-day are a source of considerable income to the laboring classes. Salt was extracted from the coast marshes and from some deposits in the Libyan desert. The national beverage was beer, seasoned with various plants. The wealthy classes drank wine of the grape and the common people the fermented juice of certain palms.

**Recreations.**—The dance to the accompaniment of the lute was a popular diversion. Acrobats and clowns performed in the royal and princely palaces. Checkers and chess much in the form of our day were also popular amusements. As regards furniture chairs and tables resembled closely those of the present day. Other articles appear to have been of simple construction. The hunting of wild animals was by coursing with dogs and the use of lasso and spear. The bow and arrow were seldom employed. Fishing was with line or net. Fowling was done in the marshy districts in boats, the weapon used being the boomerang. Traps and nets were also used. Wrestling matches and gymnastic exercises, ball-playing and juggling are often represented in paintings. Singing and music were the accompaniment of work and play, and at feasts, music and dancing, performed by members of the harem, enlivened the scene. The instruments used were the flute and a sort of whistle, the guitar, the harp, the lyre, the last two having sometimes nearly 20 strings. Assistants beat time by hand-clapping. Bow practice was engaged in and a game similar to quoits is represented, along with other games which cannot be understood in their details. T-shaped boards divided into squares like checker-boards have been found, but how they were used is uncertain. The children were not forgotten, for the tombs have yielded several specimens of their toys.

**Government.**—When the king was simply the first among equals, Upper Egypt was divided into 30 administrative departments of different grades, each having its nomarch or governor who stood as the head in everything—chief judge, district chief, military commander, tax collector, architect, treasurer, etc. As judge he was also chief priest of *Mat*, the goddess of truth. So long as the king retained supreme power this arrangement continued, but upon the decay of royal prestige each district chief aspired to leadership. This probably explains

the periods of confusion in the history indicated by the blanks between the 7th and 11th and the 13th and 17th dynasties. A new order came in during the period of the New Empire. The nomarch surrendered all his functions to the military official appointed by the king to look after his interests and to gather the taxes in kind, peaceably or forcibly as the case might be. Royal stewards and messengers, the "mouths" or "speakers" of the king appear as intermediaries. Some of the more important additional offices were those of chief judge, governor, building-master, treasurer, overseer of granaries, etc. The chief judge was a man of high standing, a prince or noble, or perhaps a priest. Beneath him were several grades in the office. Several sat as a court and before them complaint was made, prosecution and defense heard and judgment pronounced or referred to the king, according to the gravity of the complaint. The prosecutor might be a private person or a public official with whom the complaint was lodged. Confessions were forced with the bastinado. The severest punishments were the loss of ears and nose, or death by impaling, compulsory suicide, or poisoning. Accounts of trials are frequent, but no legal code has survived. In the earliest periods there was no standing army. Each nomos had its own militia and each temple its soldiers, who appear rather to have been police. This arrangement continued through the Middle Empire. The chief service rendered by soldiers in these periods was to escort expeditions to the quarries of Syene and Hammamat and to the mines of Sinai and Nubia. They also rendered service as laborers. Under Pepi (6th dynasty) a military expedition was undertaken against the Bedouin of the east. Ethiopian mercenaries formed the bulk of this force. Under Amenemha III (12th dynasty) expeditions to Nubia were undertaken and a stele of the period, now in Berlin, records the wailing which attended the visits of the conscripting officer, the "military scribe" who came "to choose out the likely youth." About this time the king came to have a body guard and during the contest with the Hyksos the armies were increased. Mercenaries, however, were constantly employed as conscription was little employed. Bowmen formed the principal arm of the mercenaries; the chariot coming into use after the Hyksos wars, was constructed to contain two persons, driver and warrior. Border garrisons were maintained to the east and south. The native weapons were the spear and shield, the axe, lance, dagger and sling. Naval warfare was little practised.

**Bibliography.**—Binion, 'Ancient Egypt or Mizraim' (1888); Birch, 'Egypt from the Earliest Time' (1875); Brugsch, 'Egypt under the Pharaohs' (1874); Budge, 'History of Egypt' (8 vols.); 'The Gods of the Egyptians' (1904); Champollion, 'L'Égypte sous les Pharaons' (1814); Erman, 'Life in Ancient Egypt' (1894); Mahaffy, 'Empire of the Ptolemies' (1895); Renouf, 'The Religion of the Ancient Egyptians' (Hibbert Lectures 1880); Wiedemann, 'Religion of the Ancient Egyptians' (1897); Wilkinson, 'Manners and Customs of the Ancient Egyptians' (1879).

**EGYPTIAN SUDAN.** See **SUDAN.**

**EGYPTIAN VULTURE** (*Neophron percnopterus*), a well-known bird which frequents

both shores of the Mediterranean, southern India and, during the winter, South Africa. It is the scavenger of Egyptian villages, collecting in numbers where carrion or garbage is deposited, but feeding also on frogs, lizards and small mammals found in cultivated fields. The birds usually go in pairs, however, and addict themselves to particular localities, being only drawn together in numbers by abundance of their favorite food. The name, as also that of Pharaoh's hen, is given because of the frequent representation of this bird in Egyptian sculpture. See VULTURE.

**EGYPTIANIZED CLAY** is the name invented for the purpose of describing a certain treatment of clay by which a clay weak in strength and in plasticity is made stronger and more plastic. In this process the clay is treated with extract of straw, tannin and other plant products. The treatment reduces the particles of clay to a state so fine that they will pass through ordinary filter paper, and will remain permanently suspended in water. The employment of the extract of straw to make the clay stronger suggested to Edward G. Acheson (q.v.), the discoverer of the process, the name "Egyptianized clay" because of the Biblical story of the use of straw in the making of bricks.

**EGYPTOLOGY**, the science of Egyptian antiquities. See EGYPT.

**EHEBERG**, ä'é-bërg, Karl Theodor von, German political economist: b. Munich 1855. He received his education at the University of Munich and in 1882 was appointed professor of political economy at Erlangen. He is best known through his masterly presentation of the subject of finance in his 'Finanzwissenschaft' (3d ed., 1891; new ed., 1909). He also wrote 'Ueber das ältere deutsche Münzwesen und die Hausgenossenschaften besonders in volkswirtschaftlicher Beziehung' (1879), and 'Das Reichsfinanzwesen' (1908).

**EHLERS**, ä'lërs, Ernst Heinrich, German zoologist: b. Lüneburg 1835. He received his education at Göttingen and Munich and in 1860 became professor of zoology at Erlangen. In 1874 he became professor of zoology and comparative-anatomy at the University of Göttingen. With A. von Kölliker he edited the *Zeitschrift für wissenschaftliche Zoologie*. He wrote 'Zoologische Beiträge,' with W. Kefenstein (1861); 'Die Borstenwürmer' (1868); 'Hypophorella Expansa' (1876); 'Florida-Anneliden' (1887); 'Zur Kenntnis der Pedicellinen' (1890); 'Magellanische Anneliden Gesammelt während der Schwedischen Expedition nach der Magellansländer' (1900); 'Neuseeländische Anneliden' (1904).

**EHLERS**, Otto Ehrenfried, German traveler: b. Hamburg 1855; d. 1895. He studied at the universities of Jena, Heidelberg and Bonn. In 1887 he went to East Africa, and later traveled through India, the Andaman and Nicobar islands, Siam, French Indo-China, Korea, Japan, the Hawaiian Islands and the United States. In a second tour he again visited India, and went to Samoa, Kaiser Wilhelm's Land and New Guinea. In an effort to traverse the latter country he was slain by his guides. He wrote 'An indischen Fürstenhöfen' (2 vols., 1883; 5th ed., 1898); 'Im Sattel durch

Indochina' (1894); 'Samoa, die Perle der Südsee' (3d ed., 1896); 'Im Osten Asiens' (4th ed., 1900).

**EHLERS**, Rudolf, German theologian: b. Hamburg 1834; d. 1908. He received his education at the universities of Heidelberg, Berlin and Göttingen. For some time he was pastor at Stolberg, near Aachen, and in 1864 removed to the Protestant Reformed Church at Frankfurt-on-the-Main, where he exercised a wide influence as a theologian. In 1878 he was made consistorial councillor, and in the following year became one of the editors of the *Zeitschrift für praktische Theologie*. He published, among other works, 'Evangelische Predigten' (1873); 'Das alte Gesetz und die neue Zeit' (1877); 'Bilder aus dem Leben des Apostels Paulus' (1886); 'Richard Rothe' (1906), and a philosophical work in Latin.

**EHNINGER**, ä'n'ing-ër, John Whetton, American artist: b. New York 1827; d. 1889. He studied under Couture in Paris and later studied at Düsseldorf. He left a number of portraits, and landscapes and figure subjects, including 'Peter Stuyvesant' (1850); 'Death and the Gambler'; 'Autumn Landscape' (1867); 'Twilight from the Bridge of Pau' (1878); illustrations for Longfellow's 'Miles Standish' (1858) and for Irving's 'Dolph Heylinger' and 'Ye Legend of St. Gwendolyn' (1867).

**EHRENBERG**, ä'rën-bërg, Christian Gottfried, German scientist: b. Delitzsch, 19 April 1795; d. Berlin, 27 June 1876. After studying theology, medicine and natural history at Leipzig and Berlin, he joined in 1820 an expedition to Palestine, Egypt and Abyssinia, returning to Berlin in 1825. In 1829 he accompanied Humboldt to the Ural and Altai ranges and to central Siberia. In 1839 he was appointed full professor of medicine, at Berlin. His great work on 'Infusoria' ('Die Infusionstierchen als vollkommene Organismen') appeared in 1838, and was at once recognized as the highest authority on the subject. It was followed in 1854 by his 'Microgeology.' Ehrenberg's work gave an enormous impetus to the study of microscopic organisms. He was the first to show that the phosphorescence of the sea is due to the presence of hosts of animalcules. Consult Lane, 'Life' (1895).

**EHRENBREITSTEIN**, ä'rën-brüt'stëin, Prussia, town and fortress on the right bank of the Rhine, opposite Coblenz with which it is connected by a bridge of boats and a railroad bridge. Tobacco, flour, leather, soap, bricks and wine are manufactured and there is a large trade in corn, wine and iron. There are several large fairs held annually. The fortress is on a steep rock, 385 feet above the river. It has massive fortifications and until the advent of heavy siege artillery was deemed impregnable. In 1799 after repeated assaults had failed and after a siege of 14 months the French succeeded in capturing it. In 1801 they destroyed the fortifications and retired. In 1826 new fortifications were completed. Pop. 5,302.

**EHRLE**, ä'r'lë, Francis, German Catholic scholar: b. Isny, Würtemberg, 17 Oct. 1845. He was educated at the Jesuit College, Münster, Westphalia, at the Maria-Laach in Freiburg, and at Ditton Hall, Lancashire, having been ad-

mitted to the Society of Jesus in 1861. After several years in mission work he was transferred to Rome, where he devoted himself to historical studies. In 1890 he became a member of the administrative council of the Vatican Library, of which he was appointed prefect in 1895. He retired in 1914. He received honorary degrees, not only from Münster (1902) and Louvain (1909), but from Oxford (1899) and Cambridge (1905). His 'History of the Church and its Literature in the Middle Ages' (in German) is based on extensive researches in the archives of Germany, England, Spain and Italy. It is on this work that his reputation largely rests; but he has further written a Latin history of the Papal Library from 1200 to 1417, and (with Stevenson) a history of the Vatican. He was placed in charge of the Papal exhibit at the Louisiana Purchase Exposition, Saint Louis. His principal works are monographs on the frescoes of Pinturicchio in the Borgia Chambers at the Vatican Palace (French 1897; Italian 1899); edition of the more important manuscripts in the Vatican Library and 'Beiträge zur Geschichte und Reform der Armenpflege' (1881).

**EHRlich**, är'lih, Heinrich, German writer on music: b. Vienna 1822; d. 1899. He studied under Henselt and Thalberg, and for a time was court pianist to George V of Hanover. He removed to Berlin in 1862 and taught the pianoforte at the Stern Conservatory there in 1864-72 and 1886-98. He also wrote musical criticisms and other articles in the *Berliner Tageblatt*, *Die Gegenwart* and the *Neue Berliner Musikzeitung*. He published 'Wie übt man am Klavier' (2d ed., 1884; Eng. trans.); 'Die Ornamentik in Sebastian Bachs Klavierwerken'; 'Dreissig Jahre Künstlerlebens 1862-92' (1893); 'Schlaglichter und Schlagschatten aus der Musikwelt' (1872); 'Aus alle Tonarten' (1888); 'Die Ornamentik in Beethovens Sonaten' (1896); 'Musik-Aesthetik von Kant bis auf die Gegenwart' (1881); 'Modernes Musikleben' (1895).

**EHRlich**, Paul, German medical scientist: b. of Jewish parents at Strehlen, Silesia, 14 March 1854; d. Homburg, 20 Aug. 1915. He was educated at the universities of Breslau, Strassburg, Freiburg and Leipzig. After graduating in medicine in 1878 he began his researches into the relationship existing between scientific medicine and chemistry, experimenting on the effects of various chemicals upon living tissue. He first chose the aniline dyes, on account of their effects being visible when injected into animals. With these dyes and their derivatives his whole life's work was concerned and his most brilliant triumphs were gained through their employment. By staining the tubercle bacillus with dyes he found that certain of them possessed a peculiar affinity for this bacillus and this accorded with the view on which he based his whole philosophy—that of the specific affinity of particular chemical substances for particular tissues, more especially for the organisms which cause disease. He next discovered a method of testing the potency of the anti-diphtheria serum by experimenting on guinea-pigs, which made it possible to standardize the serum and accurately measure the dosage. Ehrlich then found a dye called "trypan red" which cured fatal trypanosome in-

fection in mice. A further series of experiments resulted in his greatest discovery, that of salvarsan (q.v.) or 606, a specific drug with power to destroy the *spirochaete pallida*, the specific organism of syphilis. This epoch-making discovery has been described as the most potent therapeutic weapon in existence. Ehrlich laid the foundation of modern hæmatology and also performed some notable researches in connection with cancer; he formed the theory "that the growth of cancer depended on food stuffs." Almost every university and learned society throughout the world honored the great scientist; the Nobel Prize was divided between him and Metchnikoff (q.v.) in 1908; the number of his decorations conferred by monarchs and princes was greater than he professed to be able to remember. "He opened new doors to the unknown and left the world his debtor."

**EHUD**, one of the judges of Israel, mentioned in Judg. iii, 12-30; 1 Chron. vii, 10 and viii, 3; he delivered his people by stabbing to death their oppressor, Eglon, king of the Moabites. Doubt has been cast on the historical character of this hero. Consult Kittel, 'Geschichte des Volkes Israel' (Vol. II, Gotha 1909); Moore, 'Judges' (New York 1895); Nöldeke, 'Untersuchungen zur Kritik des alten Testaments' (Kiel 1869); Wellhausen, 'Israelitische und jüdische Geschichte' (7th ed., Berlin 1914); Winckler, 'Geschichte Israels' (Leipzig 1895).

**ÉIBAR**, á'ê-bâr, Spain, town in the province of Guipúzcoa, 35 miles south of Bilbao. Small arms and metal articles for decorative purposes are the chief manufactures. Pop. 9,659.

**EIBENSTOCK**, i'bën-stök, Germany, town in the southeast of Saxony, near the Mulde, 17 miles southeast of Zwickau, with important manufactures of lace. Its principal edifice is a Romanesque church dating from 1864. It is an industrial centre, the chief seat of the tambour embroidery manufactures, has manufactures of chemicals, brush handles, leather, beer and tobacco and is a cattle market. The tin mines nearby have been worked for about eight centuries, but are now practically worked out. It is connected by rail with Chemnitz, about 40 miles distant. Pop. 9,528.

**EICHELBERGER**, i-hél-bèrg-ër, William Snyder, American astronomer: b. Baltimore, Md., 18 Sept. 1865. He was graduated at the University of Johns Hopkins in 1886; was assistant in the *Nautical Almanac* office in 1889-90 and 1896-98, and from 1890-1896 served as instructor in mathematics and astronomy at Wesleyan University, Connecticut. Since 1900 he has been professor of mathematics in the United States navy. He was head of the division of meridian instrument in 1902-07, and of astronomical observations in 1907-08 at the United States Naval Observatory. In 1910 he became director of the *Nautical Almanac*. He has at various times been in charge of eclipse stations, notably at Fort de Kock, Sumatra, in 1901 and Daroca, Spain, in 1905. He is a Fellow or member of several astronomical societies and has contributed papers to government publications and to the *Astronomical Journal*.

**EICHENDORFF**, i'hën-dôrf, Joseph Baron von, German poet: b. Castle of Lubowitz, Silesia, 10 March 1788; d. Neisse, 26 Nov.

1857. He served in the War of Liberation, 1813-15, and held a position (1831-45) in the Prussian Ministry of Education. He was one of the most gifted and original romantic lyrists of Germany. His principal works are 'Presage and Presence'; 'War to the Philistines,' a dramatic story; 'The Life of a Good-for-Nothing,' idealizing vagabondage; the tragedies 'Ezzelin von Romano,' 'The Last Hero of Marienburg'; and other plays, and a number of histories of German literature, including 'The Ethical and Religious Meaning of the New Romantic Poetry in Germany' (1847); 'German Romance of the Eighteenth Century in Relation to Christianity' (1851); 'History of German Poetry' (1857).

**EICHHORN**, ih'hörn, **Johann Gottfried** German theologian and Orientalist: b. Dorrenzimmern, 16 Oct. 1752; d. Göttingen, 25 June 1827. In 1775 he became professor of Oriental languages at Jena, and in 1788 at Göttingen. He is considered the founder of scientific criticism of the literary and historical aspects of the biblical Scriptures. He edited a 'Repertory of Biblical and Oriental Literature' (1777-86); 'Universal Library of Biblical Literature' (1787-1803); and wrote 'Historico-Critical Introductions' to the Old and to the New Testament, and to the Apocryphal Books of the Old Testament; a 'Latin Commentary on the Apocalypse.'

**EICHHORST**, ih'hörst, **Hermann Ludwig**, German physician: b. Königsberg 1849. He received his education at the university of his native city and in 1877 became director of the Medical Polyclinical Institute at Göttingen. Seven years later he was appointed to the chair of pathology and therapy at the University of Zürich. He has published many important works, including 'Lehrbuch der physikalischen Untersuchungsmethoden innerer Krankheiten' (3d ed., 1889); 'Handbuch der speziellen Pathologie und Therapie' (5th ed., 1895-96); 'Handbuch der speziellen Pathologie und Therapie innerer Krankheiten' (1904); 'Hygiene des Herzens und der Blutgefäße im Gesunden und Kranken Zustande' (1906); 'Pathologie und Therapie der Nervenkrankheiten' (1907).

**EICHLER**, ih'ler, **August Wilhelm**, German botanist: b. Neukirchen 1839; d. 1887. He was educated at the University of Marburg and in 1871 was appointed professor of botany and director of the Botanical Garden at Graz. Two years later he became professor of botany at Kiel and in 1878 was appointed to a similar chair at the University of Berlin. He wrote extensively on the Coniferae, Cycadaceae and other plant groups of Brazil. His principal work is 'Blütendiagramme' (1875-78), a description of the comparative study of flowers. Other important works are 'Syllabus der Vorlesungen über spezielle und Medizinisch-pharmazeutische Botanik' (1883); 'Beiträge zur Morphologie und Systematik der Marantaceen' (1884); 'Zur Entwicklungsgeschichte der Palmenblätter' (1885).

**EICHRODT**, ih'röt, **Ludwig**, German poet: b. Durlach, Baden, 2 Feb. 1827; d. Lahr, 2 Feb. 1892. He studied at Heidelberg and Freiburg and published in 1848 in *Fliegende Blätter* his comic songs, 'Wanderlust,' which had great popularity. Among his works are 'Gedichte in

allerlei Humoren' (1853); 'Leben und Liebe' (1856); 'Hortus Deliciarum' (1875); 'Gold' (1880). His collected works were published in 1890 at Stuttgart.

**EICHSTÄTT**, ih'stët', or **EICHSTÄDT**, Middle Franconia, Bavaria, an old town in a deep valley of the Altmühl, 67 miles north-northwest of Munich. Its principal edifice is a fine Gothic cathedral, founded in 1259. It has a number of very interesting monuments in marble and bronze and here also is the tomb of Saint Wilibald. Saint Walpurgis' Church is renowned as a place of pilgrimage, great numbers congregating there annually on 1 May. Other noteworthy features are the town-hall, the ancient episcopal palace, now converted into barracks, the episcopal lyceum, seminary and municipal theatre. It has manufactures of shoes, matches, lithographic stone, etc. It is said that the city grew up about a military station of the Romans. In 908 it was chartered as a city. It suffered greatly in the many wars of the 18th and 19th centuries, being burned repeatedly by the French. The episcopal see was secularized in 1802 and added to the diocese of Bavaria but was re-established in 1817.

**EIDER**, i'dër, a river of Prussia, in Schleswig-Holstein, which rises about 12 miles from Kiel, flows generally northwest, and after a course of 112 miles, of which 69 are navigable, empties into the North Sea at Tönning, where it forms a bay. It is connected with Kiel by the Schleswig-Holstein Canal.

**EIDER DUCK**, a bird of the sub-family *Fuligulinae*, or sea ducks, genus *Somateria*, distinguished by the peculiar form and feathering of the bill, and closely allied to the scoter ducks. The several species are confined to the northern regions. The American eider (*S. dresseri*) and the European eider (*S. mollissima*) are closely similar species which breed on solitary rocky shores and islands from Maine and the Farne Islands, respectively, northward, the former species wintering as far south as the Delaware River. They are most abundant in Labrador, Newfoundland, Greenland, Iceland and Norway, where they are stringently protected by law. Both species breed gregariously and in particular spots their nests are so abundant that a person can scarcely walk without treading on them. Their nests are usually formed of grass, dry sea-weed, etc., lined with a quantity of down which the female plucks from her own breast. In this soft bed she lays five eggs, which she covers over with a layer of down; then the natives, who watch her operations, take away both the eggs and the down, and this removal is repeated as often as she lays until the close of the season, when the last lot of eggs is allowed to hatch and the down removed from the nest only after the young have left. The drake does not, as is often stated, furnish any of the down. One female generally furnishes a few ounces of down. This down, from its superior warmth, lightness and elasticity, is preferred by the luxurious to every other article for beds and coverlets; and, from the great demand for it, those districts in Norway, Greenland and Iceland where these birds abound are regarded as the most valuable property and are guarded with the greatest vigilance. Proprietors endeavor to attract them by supplying artificial nests and otherwise, and when they settle in



an island off shore, cattle and herdsmen are removed to allow them to breed undisturbed. The down from dead birds is little valued, having lost its elasticity.

The length of the eider duck is about two feet three inches, extent of the wings three feet, weight from six to seven pounds; the head is large and the bill of singular structure, being three inches in length, forked at the base of the upper mandible in a remarkable manner, running high up on the forehead, and having the feathers on each side descending nearly to the nostrils; the whole of the bill is of a dull, yellowish horn color, somewhat dusky in the middle. The male is black beneath, head and back white, with a black crown. The female is reddish drab, spotted with black, with two white bands across the wings. Eiders associate in flocks, diving to great depths for shell-fish, which constitute their principal food. They live much on the water, retiring to the shores to rest, particularly on the appearance of an approaching storm. Their flesh is eaten, but tastes strongly of fish. The eggs, however, are esteemed. These and the down are both frequently obtained at the hazard of life by people let down by ropes from craggy steep.

Other species are the Pacific eider (*S. v-nigra*), and the remarkable king eider (*S. spectabilis*) of high Arctic regions. The now extinct Labrador duck (q.v.) is closely related.

**EIFEL**, ɪˈfɛl, The, a barren and bleak plateau of Rhenish Prussia, between the Rhine, Moselle and Roer rivers, showing extensive traces of volcanic action. Its surface is diversified by crater-like depressions and volcanic peaks and ridges. It is 40 miles long and 20 wide, averaging from 1,500 to 2,000 feet in height.

**EIFFEL**, ä-fɛl or ɪˈfɛl, **Alexandre Gustave**, French engineer: b. Dijon, 15 Dec. 1832. He was educated at Dijon and Sainte-Barbe, and at the Central School of Arts and Manufacture. In 1858 he was entrusted with the construction of the large iron bridge over the Garonne at Bordeaux, and was one of the first to introduce caissons worked with compressed air. The bridge over the Douro at Oporto, the great viaduct of Garabit, in Cantal, and that over the Tardes, near Montluçon, and the gigantic locks designed and partly prepared for the Panama Canal are among later triumphs of his engineering skill; while in the huge framework erected for Bartholdi's 'Statue of Liberty' may be seen the germ of the idea which afterward assumed the form of the colossal iron structure (1887-89) on the Champs-de-Mars in Paris, with which his name is identified. He also constructed the Aerodynamic Laboratory at Auteuil. He is a member of the Legion of Honor and has received decorations from Russia, Austria, Portugal and Spain. See **EIFFEL TOWER**.

**EIFFEL TOWER**. A notable structure in Paris. The plans for the exposition of 1889 included a monstrous iron tower, to be raised on the Champs-de-Mars, 1,000 feet high. The designer, Gustave Eiffel, constructed it of iron lattice-work, with three elevators giving access to the summit. The uses of so stupendous an undertaking are many, and it became one of the chief permanent ornaments of the city. Its importance from a meteorological point of view

cannot be overestimated, the tower enabling meteorologists to study the decrease of temperature at different heights, to observe the variations of winds, and to find out the quantity of rain that falls at different heights, and the density of the clouds.

**EIGENMANN**, ɪˈɡen-mən, **Carl H.**, American zoologist: b. Flehingen, Germany, 1863. He was graduated at Indiana University in 1886 and studied at Harvard 1887-88. Between 1888 and 1892 he continued his scientific investigations in San Diego Biological Laboratory, the Woods Hole Marine Stations, and in the explorations undertaken for the British Museum in California, Oregon, Idaho, Montana, Dakota and western Canada. He was appointed professor of zoology in Indiana University in 1891 and in 1895 founded and assumed the direction of the Biological Station of Indiana University. He made scientific explorations in Cuba in 1902-04 and in British Guiana in 1908. He has contributed more than 100 papers to the proceedings of scientific societies and to scientific journals, including 'Catalogue of Fresh-Water Fishes of Central America and Southern Mexico' (1893); 'Cave Vertebrates of America' (1909); 'Egg and Development of Conger Eel' (1901); 'Fresh-Water Fishes of Western Cuba' (1903); 'Fresh-Water Fishes of British Guiana' (1911).

**EIGG**. See **EGG**.

**EIGHT-HOUR DAY**. In the struggle for the shortest hours of labor compatible with the highest efficiency, begun in Great Britain early in the 19th century, the first great landmark was the Ten Hours' Bill of 1847, enforcing in all trades what had come about in many. But the golden ideal since 1824 (announced as such by Robert Owen in 1817) has been eight hours; possibly in remembrance that such was the rule in mediæval England; partly perhaps from the tempting threefold division of the day into equal parts, as in the rhyme "Eight hours for work, eight hours for play, eight hours for sleep, eight 'bob' a day." The eight-hour movement began in Australia in 1856; by 1877 the short day was established for women workers in factories, for miners working underground and for public service employees. The movement on the Continent dates from the foundation of the "International" in 1864, and as a world-demand of the social reformers, from the Paris Trades-Union Congress of 1883. In 1916 Ecuador enacted an eight-hour law, of universal application, with exemption from labor on Sundays and legal holidays. Extra work is to be paid 25 per cent overtime, 50 per cent for overtime from six in the evening to midnight, and 100 per cent after that hour. In the United States, till recently, the subject was left to the States and to private contests, the government aiding by making short hours in its own works. In 1840 President Van Buren reduced the working day in the government navy yards to 10 hours. The first State 10-hour law, for textile workers only, was of 1849, in Pennsylvania. The first Massachusetts law was in 1874, and was due largely to the "Knights of Saint Crispin." But the eight-hour movement had long before become general: in 1866 the demand was formulated at a general workingmen's congress at Baltimore, and at other meetings; and the National Labor

Union was organized to secure an eight-hour day. A six weeks' strike in New England and New York, April-May 1866, attempted to secure it, but failed. In 1867 Connecticut and Illinois passed laws making eight hours a legal day "unless otherwise agreed." Pennsylvania followed in 1868 and New York in 1870. On 24 June 1869 the United States enacted an eight-hour day for its establishment; but the managers reduced wages correspondingly, allowing those who wished to work 10 hours at the old wages, which aroused such wrath that the President revoked the order. All these laws were rendered nugatory by the contracting-out clauses. In 1872 eight-hour leagues were formed in various places, and in Connecticut and New York a mass of strikes among the wood-working trades won this goal for a while; but the great depression from 1873 on prevented pressing such questions. Since 1880 nearly all the States have enacted eight-hour laws, subject to conditions, usually restricted to work for the State, county or municipality. The first great concerted effort for eight hours was in 1886, when 200,000 workmen went on strike; it was at an eight-hour meeting in Haymarket Square, Chicago, that the anarchist bomb was thrown. A general strike was announced for this object in 1890, but was only partially successful; several hundred thousand workmen struck, and many employers yielded, but soon advanced the hours. The first really efficient national law was of 1 Aug. 1892, enforcing eight hours upon all laborers, mechanics or contractors in the District of Columbia on public works, under pain of fine and imprisonment.

Unquestionably the shorter workday movement, which began in Great Britain about the same time as in America, had its inception in the desire to protect women and children from being overworked. Soon the labor unions recognized that it was better to ask for shorter hours than for higher wages, and so in various industries there has been a steady persistent effort for an eight-hour day, at the same wages paid for 9 or 10 hours. Widespread strikes in the building trades, the printing industry, etc., were won by the employees, and the numbers in the unions steadily increased. By 1912 it was popularly understood, both in Great Britain and America, that eight hours was a fair day's work, and liberal employers granted it very generally without pressure. However, some large industries continued to work 10 hours, notably the railways and common carriers.

In 1916 the various unions of railway workers, affiliated through the American Federation of Labor, made a concerted demand for eight hours at the same wages that were being paid for 10 hours, and threatened a general strike and tie-up of the railways of the entire United States unless their demands were acceded to. After some months of discussion, and endeavor to obtain settlement by arbitration, no agreement was reached, and President Wilson held conferences with leaders on both sides. He finally succeeded in getting a promise from the unions that the strike would be declared off if Congress passed a law providing for an eight-hour day, and a bill was hastily prepared and rushed through both houses with very little

discussion, being passed by the Democrats, by a nearly strictly party vote. It was signed 3 Sept. 1916 by the President, but its constitutionality was promptly challenged by the railway interests. The law provides: (1) An eight-hour day from 1 Jan. 1917, by common carriers and railways, excepting street railways, short independent railways and interurban railways; (2) a commission of three to be appointed to study conditions and report to the President; (3) that, pending the report of the commission, it shall be unlawful for the railways to reduce wages because of the shortened hours, in other words, they shall pay the 10-hour price for the eight-hour day; (3) a fine of \$100 to \$1,000 or imprisonment not to exceed a year or both are the penalties provided for violation. See LABOR LEGISLATION.

**EIGHT-HOUR LAW**, an act adopted in 1868 by the United States Congress, providing that in all government employment eight hours shall constitute a day's work. It originated in the agitation which had begun in England in 1833 by the proposition of eight hours as a legitimate working day. The agitation spread itself among the industrial classes throughout the civilized world, and first bore fruit in Australia in 1856, where it was adopted by several trades. The National Labor Union of the United States demanded it in 1866, and it came into effect in the government navy yards in 1869, and shortly afterward in all departments of government work. Its universal adoption, however, is still unrealized, and it is the source of persistent agitation among the labor organizations and parties throughout the United States, the British Empire and on the continent of Europe. Consult Rae, 'Eight Hours for Work' (1894). See EIGHT-HOUR DAY.

**EIGHTEENTH CENTURY**, The. Carlyle made the 18th century for readers who accepted his ideas, and they were legion, a period of extreme decadence and even degradation of interest in all that was best for humanity. He called it "the age of prose, of lying sham, the fraudulent bankrupt century, the reign of Beelzebub, the peculiar era of Cant." Frederic Harrison came in defense of the period with the suggestion that "invectives against a century are more unprofitable than indictments against a nation," and pointed out that almost all of Carlyle's heroes of the modern times apart from Oliver Cromwell are "children and representatives of that unspeakable epoch" from Frederick of Prussia, Mirabeau, Danton and George Washington to Samuel Johnson, Burns, Watt, Arkwright and others. The century was so low in its interest in architecture that it is not surprising that Ruskin thundered against it that "Satan must have had a hand in the designing of the churches of the Georgian era," and there is no doubt that its art and education were far below the standards of preceding centuries, but on the other hand it is the greatest of musical centuries, the pioneer in physical science development, and its sad history of utter neglect for the poor is redeemed to a great extent by the upward movements which made themselves felt very widely at the end of the century in politics, economics and social welfare, especially as regards the insane, prisoners and the defectives.

The last 25 years brought about more social

changes than any other corresponding period in human history. Perhaps the reason for this was, as has often been suggested, that about the middle of the 18th century a great many of the highest and best human interests, especially those concerning fellow-men who needed sympathy and aid, were lower than they had ever been before. Humanity had reached a nadir in social life from which there had to be an ascent and fortunately the reaction against the lamentable conditions which existed was strong enough to set up a humanitarian countermovement toward the end of the century which made itself felt during the course of the 19th century and has not been lost even yet. This makes the 18th century a pivotal period in modern history and therefore of ever so much more interest than many another century that represents greater immediate achievements.

What is particularly notable in the history of the 18th century is its wars in almost unbroken succession dictated by royal ambition or for dynastic reasons, while during much of the time king's mistresses or licentious women monarchs ruled the internal affairs of kingdoms. The war of the Spanish succession (1701-14) began with the century. The same first year of the new century saw the active carrying on of what was called the Northern War, lasting from 1700 to 1721. In 1718 war broke out between Spain and Austria, in the midst of which there was a formal declaration of war by England against Spain, and peace was not made until 1720. In the meantime the rebellion in favor of the Pretender, as he was called, the heir of the Stuarts who assumed the name of James III, came in Scotland in 1715 and was not suppressed until the following year. The Treaty of Utrecht (1714), which concluded the War of the Spanish Succession, changed the map of Europe as no previous treaty, not even that of Westphalia at the end of the Thirty Years War (1648), had done, but instead of settling the politics of Europe established a number of foci of irritation eminently calculated to unsettle them. Naples and Milan were given to Austria and the Austrian rule in Italy thus begun was to continue for a century and a half, always the subject of serious disturbance from within and without. Austria received the Spanish Netherlands, now to be called the Austrian Netherlands and to be a similar focus of disturbance. The Bourbon Philip V was allowed to rule in Spain on condition that the French and Spanish possessions should never be under the rule of a single individual. Great Britain received Nova Scotia and Newfoundland and the Hudson Bay region, thus precluding the expulsion of French from North America, and Gibraltar which brought with it the command of the Straits but has been a frequent subject of political irritation ever since. These wars of the first quarter of the century were only typical of the period. There was scarcely a year during the century when two important European powers were not at war; there were long series of years when a number of the states were embroiled with each other. The War of the Spanish Succession had its counterpart in what is known as the War of the Polish Succession (1733), between Austria, Russia and Denmark, with France, Spain and Sardinia becoming involved. When the Emperor Charles VI of Austria died (1740),

he left no sons, but had negotiated a treaty, the Pragmatic Sanction (1731), to secure the succession of his daughter Maria Theresa. The very year of his death saw the War of the Austrian Succession. In 1739 England and Spain were at war and in 1745 Charles Edward Stuart, the Young Pretender as he was called, encouraged by France, led an insurrection of the Highlanders. This was terminated by the bloody battle of Culloden under "the butcher" Cumberland. In 1748 the peace of Aix-la-Chapelle was signed and the various countries of Europe made mutual restitution of their conquests so as to assure future peace, only Spain and Prussia being the gainers. It was to no purpose, for France and England became embroiled in war in the early fifties; in 1756 came the Seven Years War involving most of the important countries of Europe; in 1775 the American Revolution broke out, Spain and France becoming involved in it before the end, and in 1792 the French Revolutionary wars began and for more than 20 years France was practically always at war, and over and over again the various nations of Europe were drawn into the Napoleonic wars. This by no means tells the tale of all the wars of the century, but at least it will serve to give an idea of the ever-recurring vain recourse to arms.

The monarchs of the century whose names are best known are the Georges I, II, III, in England and Louis XV in France. The English were ruled for nearly 100 years by kings who could not speak their language, or but as a foreign tongue, and whose interests were much more in their German Hanoverian dominions and mistresses than their English people. Perhaps the political conditions of the time are best illustrated by the fact that their rule caused comparatively little disaffection in England itself, though fortunately it provoked the American Revolution, which brought independence to the United States. Louis XV, succeeding to the magnificent dominions created by the genius of Louis XIV, whose personality subjugated the French people and set an unfortunate example for other European monarchs, proved utterly unworthy of his great position and allowed himself to be ruled by designing mistresses. His reign increased the debt and the taxes of the French nation until Louis XVI fell heir to an impossible situation. In spite of Louis XV's weakness, France at the end of his reign (1774) had even more territory than at the death of his grandfather, Louis XIV (1715). Social conditions had however sunk to a level almost indescribable and the reaction against them was inevitable and could not be long delayed.

Certain great political changes which took place in the 18th century had far-reaching effects on subsequent generations, some of which are only working out to legitimate conclusions in our own time. Apart from the creation of the American Republic, itself of greatest significance for the course of civilization, the three most important political changes were the establishment of Prussia as a kingdom (1701), the rise of Russia to be a great European power which began under Peter the Great (d. 1725), and the establishment of British power in India which led eventually to the erection of the British Empire. In the light of recent events probably the first of these must be considered the most

important. The electorate of Brandenburg, whose ruler was one of those privileged to elect the emperor, came under the Hohenzollern family late in the Middle Ages. It was a narrow strip of territory less than 50 miles east and west of the little town of Berlin. It is the special pride of the family that each one of the reigning heads added something to his ancestral domain. The ruler was known only as Margrave and was considered of no special importance in German life. Prussia which fell to them by inheritance at the beginning of the 17th century had been originally ruled by the Teutonic Knights who had conquered its pagan inhabitants in a Crusade in the 13th century and continued to rule it through their grand master. At the time of the religious revolt in Germany in the early 16th century the Teutonic Order was dissolved, and their lands were secularized and out of them the duchy of Prussia erected, the grand master of the time occupying what had hitherto been an elective office now becoming the Duke of Prussia with the right of inheritance. He was a relative of the Elector of Brandenburg and when this branch of the Hohenzollerns died out the duchy was united to Brandenburg, the Hohenzollerns now ruling over such distant provinces as Cleves and Mark in the Rhineland and Prussia far to the east. The great elector as he is called succeeded in welding these widely separated territories into a strong state. His son, Frederick I, obtained from the emperor, for military aid rendered, permission to change his title from elector to king though he was but king in Prussia as he did not rule over the whole of Prussia, but he preferred this title because his Prussian dominions were outside the Imperial limits and he was more independent. After the partition of Poland his title became King of Prussia.

His son, Frederick William I, though noted more for his eccentricities and for his rude boorish manners than for interest in anything higher, consolidated the Prussian dominions, created an army of nearly 100,000 men, drilled and trained probably better than any other soldiers of the time. He was almost miserly in his penuriousness with regard to anything except military expenses, reduced the number of his court servants, coined the family silver and sold most of the royal jewels at auction. He left his son, Frederick II, a magnificent army and a well-filled military chest. Frederick II, to be known in history as the Great, whose interest in literature and the arts had disgusted his father in his youth, had no sooner ascended the throne (1740), at the age of 28, than he proceeded to use the military advantages which his father had secured for him to the utmost. Maria Theresa having ascended the throne in Austria the same year, Frederick, taking advantage of the expected weakness of a female ruler, without any reasonable grounds laid claim to Silesia and began the War of the Austrian Succession. He enlarged his territories in every way that he could, showed great military genius in his campaigns and devoted himself to the encouragement of arts and sciences, the building of public structures for music and libraries and built a series of palaces, not all of them in good architectural taste, but not behind that of the century in which he lived. He especially enriched the city of Berlin with

public buildings and though he encouraged French more than German literature did much for the intellectual life of the Prussian people. Under him Prussia became an important power in Europe.

The second of these great political changes of the century was the rise of Russia. This was mainly due to one man, Peter, to whom history has given the title of The Great. The house of Romanoff came to the throne of Russia on the extinction of the dynasty of Rurik 1598. The 17th century was spent in breaking the power of the nobles, encouraging mining, manufactures and commerce and increasing Russian territory in the west at the expense of Poland. Peter the Great came to the throne in 1699 and reigned till 1725. He insisted on introducing the ways of European civilization, shaving off the beards of his nobles and cutting short their long gowns himself when they refused to obey his order in the matter, for he declared that people so dressed and bearded could not be good soldiers. He made war on the Turks and conquered Azov. Just at the beginning of the 18th century, Peter made his way to Holland because he felt that Russia must have an outlet to the sea and that Holland could teach her lessons in shipbuilding. He worked as a ship carpenter for a while at Zaandam in Holland and studied the shipbuilding methods of the English on the Thames. He returned to put down an insurrection in Russia and the Cossacks under Mazeppa (1707), and then proceeded to take territory away from Sweden which would allow him an outlet to the Baltic Sea. He established nearby his capital, Petersburg, his desired "window into Europe," at immense expense, setting it up on piles in the swamps. In spite of the fact that Peter was succeeded by his wife, Catherine, who reigned for several years, and that between Elizabeth and Catherine II for most of the rest of the 18th century Russia was ruled by women of the most licentious personal character, whose favorites had much to do at least with the internal affairs of the empire, the country continued to gather strength and importance in Europe until at the beginning of the 19th century it was one of the strong factors against Napoleon on many occasions. German intrigue riddled the country, however, and especially under Elizabeth and Catherine II succeeded in Germanizing the nobility to a great extent and especially the bureaucracy and keeping the Russian people in the worst possible condition of serfdom and subjection.

The third important political event of the 18th century was the subjection of India to England. About the middle of the 18th century the French, owing to the genius of Dupleix who had been governor of Pondicherry since 1741, came into prominence in Indian affairs. Dupleix dreamed of a French empire in India following the lines of the old Mogul Empire which had fallen at the beginning of the 18th century. Robert Clive who went to India as a clerk took on himself to make head against Dupleix who was unsupported by his own government. In the midst of the wars between England and France which occurred around 1750, the American events of which are Braddock's defeat and the French and Indian War, and during the Seven Years War, Clive gradually built up the Indian Empire, often under

conditions that would not have been approved at home but that once concluded were accepted as accomplished facts. As a result at the beginning of the 19th century some 300,000,000 people in India were under English rule.

The American Revolution beginning apparently as a revolt on the part of scattered rather disconnected colonies with less than 3,000,000 of inhabitants and even those by no means strongly welded together, and with a very large party among them who remained loyal to England, so that success seemed almost impossible, ended with a triumph that gave genuine democracy almost its first great opportunity in the world's history. In a new land far from the disturbing political conditions of European countries and with magnificent resources to develop, the American Republic proceeded to exemplify what government of the people, by the people and for the people may mean. De Tocqueville's 'American Democracy,' written 50 years later, is the tribute of a young enthusiastic European republican to America's success. Undoubtedly the colonists owed their successful termination of the Revolution to the aid of the French, though the kingdom of France under Louis XVI was tottering to its fall and that fall was hastened by the very success of the spirit of democracy in America. From Lexington to Yorktown represented seven long years of the severest trials borne with magnificent courage and persistency by the colonists, hampered by a large royalist contingent among them, and these virtues had their own reward. The result was a solidarity of feeling owing to sympathy and union in suffering which more than all else served to bring the colonists together. The 13 colonies had been anything but homogeneous in race and character and they were almost infinitely dissimilar in attitude toward religion and life. The Puritan of New England and the Cavalier of the Virginias and Carolinas represented opposite poles of feeling in almost every way. It was hard enough indeed after the Revolution to bring them together or secure a working *modus vivendi* for their government, but it would have been quite impossible only for the long years of bloodshed and the severe vicissitudes through which they had passed in the period of travail from which the new Republic of the West was eventually born. It has well been called the greatest fact in modern history; the greatness of that fact has been enhanced by the part which the American Republic, now one of the largest of the nations, has taken in the World War for democracy.

The greatest man of the 18th century was beyond all doubt George Washington. It was the custom sometimes to speak of him as owing his reputation to a series of happy accidents rather than to innate genius. Having been chosen the general of the Colonial forces, it was said that he succeeded in holding out against the British whose mistakes were so great as to facilitate this until the alliance with France and then with Spain finally brought that combination of regular military strength and organization which made Yorktown possible and brought a happy ending to the Revolution. Any such view, however, is contradicted by definite knowledge of the man. When scarcely more than a youth he had saved Braddock from total defeat in spite of that general's utter

errors. The campaign around Boston added further to his military reputation. The battles of Princeton and Trenton have been acknowledged by modern military experts as one of the greatest series of strategical combinations under the most discouraging circumstances that have ever been made. The official documents of Washington show clearly how large and noble was his mind. His advice is still the best policy of the republic in spite of its broad extension beyond anything that he could ever have imagined in his wildest dreams. His declination of the presidency for the third time and the consequent tradition of but two presidential terms was a precious heritage for the nation, and the final proof of his magnanimity. Time instead of lessening his prestige has added to his reputation and made it clear that he was a great man raised up to fit a great occasion.

The saddest chapter of the 18th century is that of the social conditions. In order to explain the French Revolution so much attention has been devoted to social conditions in France that there has come to be a very general impression that social abuses were at the worst in that country. As a matter of fact with the exception of England the poorer classes were better off in France than anywhere else in Europe. The awful picture of the *Ancien Régime* is true, but it should be remembered that the German lower classes were in still worse condition and the Russian serfs were quite literally slaves and life and death was practically in the hands of their masters. The nobility in all the countries apparently felt themselves to be of quite different clay from the human beings below them in the social order and treated them accordingly. With the coming of the capitalist class as the result of the industrial revolution something of this same feeling was to develop on the part of rich employers to employees. Whenever human nature has the chance it imposes on those below it and it must not be forgotten that the Declaration of Independence in the last quarter of the century was written and most strongly upheld by men who thoroughly believed in the institution of negro slavery and insisted on maintaining it for nearly a full century.

The most shocking element in social conditions was the utter neglect of the wards of the state, prisoners, the insane, feeble-minded and the poor. The awful conditions which existed in prisons and hospitals were described by John Howard toward the end of the century who brought about a beginning of reform. The prisoners were huddled together utterly regardless of their influence on each other, the young and the old, the first offender and the hardened criminal, and the treatment of women was almost worse than that of men. Hundreds of women in London prisons were crowded together, some of them women of the streets and some accused of little thefts to keep their children alive, and with many of the prisoners children were allowed to be there because there was no one else but their mother to care for them. Nearly 250 crimes were called felonies and were subject to punishment by hanging. Poor women were often hanged for having passed a counterfeit pound note which sometimes they themselves did not know was a counterfeit and the fact that they had children at their breast or were

in an early stage of pregnancy was no mitigation of their offense. The insane who had ever shown any sign of violence were shackled and were seldom allowed to be free again. The quarters in which the insane were cared for were filthy beyond description and they were often confined in cells underground or chained to the walls of dark rooms into which the sunlight never penetrated. Quaker philanthropists in England began a crusade for the reform of insane asylums which slowly gained ground and the movement spread to America. It had been the custom to permit visitors in search of amusement to stand at windows where they could view the antics of the insane, a small sum of money being collected for this privilege. This amusement became so popular that many thousands indulged in it every year and the fee constituted an important source of revenue. Pinel in France dared to strike the shackles off the insane in the great asylum and hospital at Bicetre though a great many even of his medical colleagues were convinced that it was a dangerous proceeding. The care for the defectives and for the poor in the poor-houses continued to be almost unspeakably bad until well on into the 19th century, and indeed in some cases until our own time. The serious idea of reform in these matters, however, began to take hold of thinking people before the end of the 18th century. The United States was a leader in these reforms. When de Tocqueville visited America and gathered the material for his book on Democracy he was here as a member of a commission to investigate our prison system in order to secure the reform of French prisons.

Personal liberty on the Continent had sunk to a very low ebb indeed. Most of the rulers were absolute monarchs and there being no written guarantee of rights men had almost no redress against the monarch's ill will in their regard if he wished to exercise it. In France particularly the king might order the imprisonment of a subject no matter what his rank and keep him in prison for any length of time that he wished. This process was accomplished under a sealed document issued by the king called a *Lettre de Cachet*. This mode of imprisonment had been very much abused under Louis XIV, but the abuse reached a climax under Louis XV when it is said that over 150,000 sealed orders were issued. Sometimes men thus imprisoned would be entirely forgotten and the reason for their imprisonment be quite unknown. A clause of Magna Charta made any procedure a violation of the rights of Englishmen, but in other countries the practice was quite common. When the Bastille fell (1789) some of these prisoners were found for whose imprisonment no reason could be discovered.

A profound reaction in social matters was due in Europe. It came with the French Revolution, in 1789. Begun as an attempt to distribute the burdens of taxation more equally on the French, or indeed to solve the problem of the bankruptcy of the country, it developed into a great outburst of the oppressed classes. As Hilaire Belloc who probably knows the period better than anyone in our time suggests it was an organized effort to win back for men some of the privileges which they had enjoyed in the Middle Ages. In that sense it continued

to make itself felt all during the 19th century and down to our own time. It is this aspect of the movement that has until now not been properly appreciated. Hailed by all the liberal thinkers of Europe as a new dawn for civilization the Revolution degenerated into the saddest of butcheries, and gave place to utter anarchy until the French people themselves, tired of bloodshed, welcomed a military dictator with power to maintain public order. In 1789 the States-General were summoned for the first time since 1614. This was changed shortly into the National Assembly. A new constitution was proclaimed in 1790. In 1792 the monarchy was abolished and the next year the well-meaning but unfortunate Louis XVI was put to death and Marie Antoinette, his queen, Maria Theresa's beautiful but imprudent daughter who had been the admiration of Europe, followed. These events alienated all Europe and the new republic fought them all in combination and won battles that enabled her to extend her territory but finally brought her under the heels of a military despot.

The most compelling figure of the 18th century is Napoleon Bonaparte and his career is the index that French affairs had reached a point where reaction was inevitable. This product of the time was, to quote Freeman, "nearer to being the master of Europe than any other man had been before." "He called himself consul and an old Greek would have said that he had made himself tyrant, but he was a more absolute ruler than ever Louis XIV had been." One of the last reflections made by Gibbon, the historian of the Roman Empire, whose wide knowledge of world history would seem to give him a right to an opinion on the subject, was that the world would never again see a great conqueror arise who like Alexander or Cæsar might threaten to have the world under his domination. Gibbon died in 1794. Had he lived but a scant 10 years more he would have been able to witness the utter contradiction of this opinion, though there is no doubt now that most of the learned men of his time and especially those familiar with history would have accepted his reflection as almost so obvious as to be an axiom. In this after all Gibbon differed very little from many a serious student of history of a century later who would not have hesitated to say that he now felt sure that a great prolonged European war shared by most of the civilized nations of the world was an utter impossibility.

Bonaparte was carried to the height of power on a flood of military success. Arrived there he proved to have a genius for administration that enabled him to maintain himself and that has stamped his influence on all modern legislation. He came to the front in the Italian campaigns of the wars of the French Revolution when his victories in Italy forced the Emperor Francis of Austria to surrender the Austrian Netherlands to France and to withdraw from northern Italy with the result that Piedmont and Savoy were annexed to France. France was a republic, but there was no republicanism in the spirit of French conquests once the mania of victory developed. Republics were sacrificed quite as readily to French ambition, or rather to the ambition of French military leaders, as were monarchies. In return

for his surrender to France of these large territories the Austrian emperor was permitted to join the French in destroying the ancient commonwealth of Venice, which with all that was oligarchical in its government had at least some show of self-ruling about it. The French and the Austrians divided the Venetian territories between them. When in 1798 Bonaparte planned his expedition to Egypt and the French needed money to finance it the Directory of France calmly proceeded to attack Switzerland, for some six centuries a republic, for no better reason than because the town of Berne was known to possess a large treasure. The French Revolution would seem then utterly to have failed in its purpose, but it was only an eclipse for a time and in spite of many vicissitudes its spirit was to work for good for more than a century later. Napoleon came to be the hammer by which a great many of the presumedly most firmly established things of the old order in Europe were smashed upon the anvil of war to be made over for the better, though the betterment was often not immediate.

The greatest woman character of the century in the best sense of the word was Maria Theresa, queen of Austria or "king," as her Magyar subjects loved to call her, and finally Austrian empress. Her father had anticipated trouble for his daughter's rule and made the treaty called the Pragmatic Sanction to secure it, but his worst portents were confirmed and Maria Theresa was scarcely seated on the throne before she became embroiled in a series of wars for the preservation and integrity of her states. Probably no woman in history has ever taken her duties as sovereign more seriously. On the other hand as the mother of 17 children she took her domestic duties quite as seriously and was a model wife and mother. Her letters to Marie Antoinette during the French troubles show her maternal solicitude at its best and her wisdom as a ruler and administrator. She treated her subjects very much as she did her family, with the most loving care and profound wisdom. She practised strict economy, encouraged manufactures and commerce, reformed the army with the idea of preventing bloodshed by being prepared for war, and organized a system of military colonies on the frontiers so as to prevent invasion and save her subjects from the worst hardships of war, that of having the enemy in their midst. Above all Maria Theresa won the love of all the different peoples who composed her multilingual kingdom. It has always been a historical mystery why the heterogeneous peoples who constitute the Austrian Empire have hung together and it has often been supposed that it was a mere question of armed force and repression. There can be no doubt, however, that there was real attachment to the house of Hapsburg and that above all Maria Theresa's long reign of nearly 50 years had much to do with creating a spirit of solidarity among these peoples. Her readiness to do for the suffering among her people was literally unbounded. It is said that once she was driving through a part of the country where famine was rife and people were starving. Passing by a mother seated at the roadside trying to nurse her child, and evidently unable to supply it with food, the empress threw a piece of

money into her lap and told her to get something to eat, but the mother with tears in her eyes insisted that it would be too late to save her baby. The mother of 17 children might well be expected to be in a condition to supply for lack of infant food, and so the starving baby nursed at the Imperial breast and its life was saved. It is easy to understand that among peoples who had traditions of acts of this kind on the part of their empress queen, deep feelings of affection would be aroused to become a tradition in favor of the family of which she was a member.

The one thing that stains the reign of Maria Theresa is the partition of Poland. There is no doubt at all that she entered upon it with great unwillingness and felt that she was forced to take part lest there should be such a disturbance of frontiers and the balance of power in central Europe as would leave her kingdom and people open to attack under unfavorable conditions. Perhaps another fault was the association of her son Joseph II in the government. Maria Theresa was a woman of heart and high administrative powers. Her son Joseph was an intellectual prig who was quite sure that humanity could be made better by rules and regulations and that men could be governed by sweet reasonableness and intellectual reform. His career as a ruler was an utter failure. He tried to make himself a benevolent autocrat for the benefit of his subjects and was so terribly disappointed by his failure that he died a broken-hearted man before he was 50.

Women were destined to play an extremely important rôle in 18th century history. The reign of Queen Anne is a great period in English history but unfortunately unworthy women were to be the most influential characters of the time. The most noteworthy of these whose career is typical in many ways of the lamentable political influences that were at work was Catherine II, the empress of Russia, who reigned from 1762 to 1796. She was not a native Russian, but a princess of Anhalt-Zerbst in upper Saxony. Her name Sophia Augusta was changed to Catherine on her admission into the Greek Church just before her marriage with Peter who had been selected to succeed his aunt, the Empress Elizabeth, on the throne of Russia. She was not the first thus to be lifted from obscurity to the high position of empress of the Russians, for her earliest predecessor in the 18th century, Catherine I, the wife of Peter the Great, who reigned for two years after his death, 1725 to 1727, was the natural daughter of a country girl in Livonia. The first Catherine, after having been the mistress of a series of Russian generals, attracted the attention of the tsar and became his mistress and subsequently his wife. She died at the early age of 40, her end being hastened by dissipation. She never learned to read or write, but she knew how to manage men. The second Catherine was quite as dissipated, and had even more administrative ability, but she had devoted herself to her own education until she came to be looked up to as one of the scholars of the time. She was a friend of Voltaire and of the Encyclopedists. She was a great believer in the new social philosophy which they preached, and maintained cor-

respondence with them. Her husband frittered away his life in senseless dissipation, but while the Empress Elizabeth lived, Catherine maintained some show of respectability and acquired deep influence over her. Her mode of life, however, soon became such as to make the paternity of her children a matter of grave doubt. With the death of Elizabeth the half-imbecile Peter, her husband, soon got into serious difficulty with his people and his nobles, and Catherine through her lovers took advantage of this to secure the throne.

All during her life Catherine continued to live most licentiously. One lover succeeded another, though one favorite, Potemkin, maintained his influence over Catherine for some 15 years, supplying her with new favorites when his mistress's personal inclination for himself suffered an interval or ceased entirely. Catherine's lovers are said to have cost Russia over \$100,000,000 at a time and under circumstances when money was worth at least five times as much as it is now. In spite of this utterly depraved personal character Catherine ruled Russia for Russia's advantage though not for the benefit of her subjects. She pursued relentlessly the policy of giving Russia an egress for its commerce by sea. She succeeded in bringing Courland with its Baltic coast line into the Russian Empire, had Poniatowski, an old lover, elected to the throne of Poland, and finally brought about the infamous division of Poland — Catherine obtaining about two-thirds of the Polish territory. An insurrection of the people under Kosciusko, the Polish hero of the American Revolution, failed, the Russian army stormed Warsaw and the last trace of Poland as an independent country was obliterated (1794). It was the foulest deed in history. War with the Turks led to Catherine's conquest of Bessarabia and other countries down to the Caspian and came near realizing the Russian empress' dream of driving the Turks entirely from Europe and the establishment of her own empire at Constantinople. She was completely alienated from all sympathy for French ideas by the progress of the French Revolution and prohibited the publication of French works in Russia. French admirers used to call her the Semiramis of the North and her career, political and moral, amply justifies the comparison, with the moral balance in favor of the ancient ruler who anticipated Catherine by some 2,500 years. It was the presence of such rulers as herself and Louis XV during the 18th century that brought about the reaction against monarchical government which was to attract so much attention during the 19th century.

This century contains the most important chapter in the history of music. Scarlatti (1659-1725) who wrote some hundred operas, a number of oratorios and an immense amount of ecclesiastical music, introduced three novelties destined to influence music deeply. The two principal of these are the Sinfonia or Overture and the accompanied recitative. Every country in Europe took up music and made distinct contributions to it. Purcell's work in the 17th century in England had finely prepared the public mind, and Handel and Bach completed the organization of the art of music on a firm footing. It has been said that "these two great composers of the 18th century, wrote

every combination of musical notes that down to our latest times has ever been employed with good effect." . . . "The more the works of these masters are studied the more are they found to foreshadow the supposed novelties in harmony, employed by subsequent artists." (MacFarren, 'Encyclopædia Britannica'). The period includes also the life and works of Glück who did so much to unite music and plot in opera into one harmonious whole. Piccini, Glück's rival in the famous musical war in Paris, was a much less important musician, but he had dramatic power and real musical talent. Haydn, often spoken of as the father of the symphony, contributed greatly to the development of music and some of the sons of the great Sebastian Bach have an enduring place in the history of musical art. Mozart whose untimely death at the age of 35 cut him off in the flower of his achievement is one of the greatest musicians of all time. Before the end of the century Beethoven had rounded the symphony into its modern form and left the world eternally his debtor for his marvelous command over notes. The opera comique of the French which dates from early in the 18th century, the distinction from grand opera being that there was spoken dialogue interspersed with the music, provided opportunity for the development of lighter music that was to occupy so much attention in modern times. What is noteworthy, however, in the 18th century is the depth and seriousness of interest of even the general public in music. Handel's oratorios were given to crowded houses and as Frederic Harrison has said "the ill designed churches of the period were often crowded with people who were deeply touched by the sacred music given and whose emotions were heartfelt and not at all the result of any fashionable or conventional feeling."

The literature of the 18th century, opening with 'The Rape of the Lock' and closing with Goethe's 'Faust,' must surely be considered as of significant import in the history of literature. It includes in Germany the work of Winckelmann, Lessing and Herder, as well as the youth of Schiller; in France the writings of Montesquieu, of Voltaire and the Encyclopedists, and in England such historians as Hume, Robertson and Gibbon, as well as such potent writers of English prose and verse as Addison, Steele, Samuel Johnson, young Wordsworth and Robert Burns. Frederic Harrison has suggested that it is the first age since that of Augustus which ever left inimitable pictures of its own daily home existence. The *Spectator*, Walpole's and Fanny Burney's letters and the novels of Richardson, Fielding and Smollett have given a picture of the times that has probably never been equalled. What is interesting above all about the literature of the 18th century is its interest in ordinary human beings. The problems of men as men were here first stated in literature and sympathy aroused for even the lowest of mortals. Gay's 'Beggars Opera,' Crabbe's 'Tales' and Defoe's and Swift's romances are representative in this regard. Defoe and Swift wrote from so close to the heart of human nature that their best works are forever popular.

Education reached a very low ebb in the



18th century so that Cardinal Newman suggests the middle of the century as representing probably the lowest period in the history of university education, when the students at Oxford and Cambridge scarcely more than "ate their terms," that is, lived in residence to receive their degrees, while Winckelmann, wanting to teach Plato at the end of the century, had to have manuscript copies of the author because no Greek edition had been issued in Germany for over 100 years. Philosophy, however, was the subject of a good deal of attention and exploitation usually on the part of men not directly connected with the universities. It is the age of Locke, of Hume and of Bishop Berkeley in England, whose stay in America influenced Jonathan Edwards, of Voltaire and the Encyclopedists in France and of Kant in Germany. The work of these men lived to influence the 19th century. Religion was at a low ebb and it was an age of scepticism. The work of the devoted John Wesley in England, which proved the incentive for the Oxford Movement of the succeeding century, was the first index of reaction. French philosophy in its atheistic aspects was curiously enough a child of English scepticism. Voltaire and the French Encyclopedists (see *ENCYCLOPEDIA*) attracted attention rather by the brilliancy of their style, the keenness of their wit and their biting satire than by depth of thought. Voltaire himself pronounced the period an "age of trivialities." Rousseau suggested the abandonment of artificial culture and refinement and the going back to the primitive state of nature because it seemed hopeless to guide men by reason. Adam Smith's 'Wealth of Nations' represented the English philosophy of independent morality applied to practical life.

The 18th is above all the century of the fundamental organization of the physical sciences in their modern form. The period crystallized the data of scientific information, till then held in solution, and gave the physical sciences the form they have maintained since. Physics, chemistry, botany, zoology, comparative anatomy, electricity and psychology as well as the elements of social science both in history and in statics took shape. Lancisi at the beginning of the century in Italy and at the end of the century Hunter and Bichat in England and France revolutionized methods and results in the sciences related to medicine. Morgagni founded pathology. Jenner's discovery of vaccination marked the dawn of a new era in therapeutics. Auenbrugger initiated clinical diagnosis, and the example of such men as Percival Pott, after whom Pott's disease (q.v.) and Pott's fracture are named, gave a new impetus to accuracy of surgical diagnosis. The Vienna School of Medicine began its work as an inheritance from some great students of Boerhaave at the beginning of the century, and such men as Cullen, Heberden, Currie, Fothergill. Huxham left an indelible impress upon medical history. Franklin, Galvani, Volta laid the foundations of the science of electricity while Priestley, Lavoisier and Scheele were doing similar work in chemistry. Laplace, La Grange and others were adding to the magnificent work that Newton had accomplished at the beginning of the 18th century, recognizing very clearly the surpassing value of their predecessor's work. La Grange declared that Newton, whose 'Prin-

cipia' received its final form in this century, "was the greatest genius that ever existed." Beside him deserve to be named such men as Halley of the comet, Euler, the Bernouillis, the elder Herschel and Legendre. The century was also particularly fruitful in mathematical genius. In the biological sciences Cuvier, Buffon, Geoffroy St. Hilaire and Lamarck, most of whose work was accomplished before the century closed, did work that was destined to leave its impress deeply upon their sciences. It required much more than merely talent and application to make the first great steps in these sciences and only positive genius could have done what these men achieved.

The greatest heritage of the century to succeeding generations was what has come to be called the industrial revolution. Up to the latter half of the 18th century men had paid very little attention to mechanical inventions and their development. The people of western Europe did their farming, made their cloth and continued to do most of the domestic manufactures at least almost in the same way as the ancients had done. It has been said that "if a peasant, a smith or a weaver of the age of Cæsar Augustus had visited France or England 1800 years later he would have recognized the familiar flail, forge, distaff and hand loom of his own day." (Robinson). All this was to be changed in the course of a single generation, however. A series of machines came to replace hand labor and accomplish ever so much more in vastly shorter time than before. The essential processes remained the same, only now by the aid of machinery they were accomplished more rapidly.

In 1767 Hargreaves, an English spinner, invented what was called the spinning jenny. With this a single workman by the help of a wheel could spin 8 or 10 threads at once and thus do the work done formerly by as many spinners. In 1768 Arkwright invented a machine for rolling threads. Some 10 years later Crompton combined Hargreaves' spinning jenny and Arkwright's roller machine into what was called the spinning mule. With this as many as 200 threads could be spun at once, and when the steam engine came and power was applied a few hands could do the work of hundreds. The gradual improvement of the steam engine by James Watt, who had been called in to repair a model of a steam engine made more than half a century before by an English mechanic named Newcomen, greatly facilitated the development of industry. In 1785 a steam engine was first employed to run spinning machinery, Arkwright adopted it in 1790, and after this such engines became extremely common and the factory system replaced the old domestic system of manufacture almost completely.

This so called labor-saving machinery threw many out of employment, though it brought together a great many workmen in the employ of a new class that now developed in the population, the capitalist. John Stuart Mill about the middle of the 19th century, when he could see clearly the result of the industrial revolution, declared that all our labor-saving machinery in spite of its name had never saved mankind an hour of drudgery, but on the contrary had made it possible for a large number of workmen to work for a few and usually to

work long hours in unsanitary, ill-ventilated factories, compelling them to live in crowded slums not far from the factories because their long working day did not allow them the time to go or come farther to their work. The industrial revolution worked an immense amount of social harm, led to the employment of women and children for such long hours and under such unsuitable conditions as proved seriously detrimental to health, and it took more than a century before humanity wakened up to the necessity for regulating industry in such a way as to conserve the rights of man.

JAMES J. WALSH,

*Author of 'The Thirteenth the Greatest of Centuries.'*

#### PRINCIPAL EVENTS OF THE 18TH CENTURY.

1701. Frederick (III) Elector of Brandenburg is crowned first King of Prussia, 18 Jan.
1702. Anne, Queen of Great Britain, begins her reign.
1703. St. Petersburg is founded by Peter the Great.
1704. Battle of Blenheim.
1707. The union of Scotland with England is ratified and the first parliament of Great Britain assembles.
1708. The British defeat the French at Oudenarde.
1709. Charles XII of Sweden is defeated at Pultowa, 30 June. Battle of Malplaquet, 11 Sept.
1713. Treaty of Utrecht signed, 30 March.
1714. George I, Elector of Hanover, becomes King of Great Britain.
1715. Scotland revolts; the Stuart Pretender appears, but his supporters are defeated at Sheriffmuir. Louis XIV of France dies.
1717. The Turks are defeated at Belgrade.
1718. Charles XII of Sweden is killed at the siege of Frederickshall, Norway.
1720. The South Sea Scheme, 7 April-29 September, collapses. Victor Amadens, duke of Savoy, becomes King of Sardinia.
1722. Peter the Great assumes the title of Czar of Russia.
1725. Death of Peter the Great. Persecution of Protestants in France.
1727. George II becomes King of Great Britain.
1728. Rise of Methodism in England.
1733. France and Poland at war.
1736. Kien-Lung ascends the throne of China. He receives embassies from Russia, Holland and Great Britain.
1739. Nadir, Shah of Persia, conquers the greater part of the Mogul Empire.
1740. Frederick the Great begins to reign. Maria Theresa becomes Queen of Hungary.
1743. The Allies defeat the French at Dettingen.
1744. Great Britain declares war against France, 31 March. Commodore Anson completes his voyage around the world.
1745. Battle of Fontenoy, 30 April. British forces take Cape Breton, N. S. Rebellion in Scotland. English forces defeated at Gladsmuir, 21 Sept.
1746. English forces defeated at Falkirk, 17 Jan. Scotch forces defeated at Culloden, 16 April, and the rebellion suppressed.
1747. Defeat of the allied army at Lafeldt. British victory over the French fleet. The Prince of Orange becomes Stadtholder.
1748. Treaty of Aix-la-Chapelle between Great Britain, Spain, Austria and Holland.
1752. Calendar revised in Great Britain, Sept. 3 becoming Sept. 14.
1756. Seven Years' War begins. Rupture between Great Britain and France.
1757. Damien's conspiracy against Louis XV. Prussian victory at Rossbach over French and Austrians, 5 Nov. King of Prussia becomes master of Silesia.
1759. France loses Canada in the final battle of the Heights of Abraham.
1760. George III begins his reign.
1763. Seven Years' War ends with Frederick victorious. Peace ratified at Paris between Great Britain, France and Spain.
1764. The British Parliament grants Mr. Harrison \$50,000 for discovering the longitude by his chronometer.
1766. American Stamp Act repealed.
1769. Captain Cook's discoveries in the Pacific Ocean.
1772. First Partition of Poland by Russia, Prussia and Austria. Revolution in Sweden.
1773. Captain Cook's voyage to the Antarctic, reaching 71° 10' south latitude.
1774. Louis XVI of France begins his reign.
1775. The American Revolution begins, 19 April. Battle of Bunker Hill, 7 June.
1776. The American Declaration of Independence proclaimed, 4 July.
1777. The surrender of Burgoyne at Saratoga, N. Y., 7 Oct.
1778. Alliance of the French and Americans, 30 Oct.
1779. Siege of Gibraltar. Captain Cook killed at Hawaii.
1780. British naval victory over the Spaniards near Cape St. Vincent, 16 Jan. American defeat at Camden, 16 Aug.
1781. The surrender of Cornwallis at Yorktown, 18 Oct.
1783. Treaty of Peace between Great Britain and the United States.
1786. Warren Hastings impeached for misrule in India. Shay's rebellion in Massachusetts.
- 1787-88. United States Constitution drafted at Philadelphia and ratified.
1789. The States General meets in Paris. The French Revolution begins. The King accepts the declaration of the Rights of Man. France divided into 83 departments. Washington elected President of the United States.
1790. Titles of nobility suppressed in France.
1791. Coalition between Austria and Prussia, 27 Aug. The French Constitution ratified, 3 Sept.
1792. Peace of Jassey, 9 Jan. Gustavus III of Sweden assassinated, 16 March. The September massacres in France. France declared a republic, 22 Sept.
1793. King Louis XVI beheaded, 21 Jan. Queen Marie Antoinette beheaded, 15 Oct. War declared by England against France, 1 Feb. Toulon captured by the English, 28 Aug. Reign of terror in France.
1794. Robespierre beheaded. English defeat the French fleet. Battle of Fleurus, 26 June.
1795. Holland invaded by the French. Belgium annexed to the French Republic. The remainder of Poland partitioned between Russia, Austria and Prussia. Jay's treaty between United States and Great Britain.
1796. Bonaparte's campaign in Italy.
1798. Irish Rebellion. Bonaparte's campaign in Egypt. The Battle of the Pyramids.
1799. The siege of Acre. Bonaparte made First Consul. Death of Washington.
1800. United States capital removed from Philadelphia to Washington. Union of Ireland with Great Britain ratified by Parliament.

**EIGHTH CENTURY, The.** The 8th century is a cardinal epoch in modern history because it witnessed the culmination of the struggle in the east and west of Europe by which it was decided that European civilization should be Christian rather than Mohammedan in character. The failure of the Saracens to capture Constantinople in the early part of the century (718) and the decisive defeat inflicted upon the Moors at Tours (732) by Charles Martel followed by Charlemagne's successful campaign (777) which pushed Moorish dominion below the Ebro in Spain definitely settled that Christianity was to have an opportunity for free development in Europe. It was the fashion a generation or two ago to suggest the possibility that civilization might have advanced more rapidly under Mohammedan dominion than actually proved to be the case under Christianity. The opinion was dictated primarily by the love of paradox though undoubtedly supported by the tendency to minimize the really great work of the Middle Ages through ignorance of their genuine achievement and to exaggerate the place of the Moors in education, literature and, especially, in science. What actually happened in the Mohammedan countries in spite of the magnificent incentive afforded them by their close touch with Greek civilization in the East is the historical demonstration that their definite repulse in the 8th century was for the benefit of humanity.

At the beginning of the 8th century the caliphs ruled from India over Persia, Arabia, Syria, Armenia, Egypt, Morocco, Spain and what is now France beyond Narbonne, as well as most of the islands of the Mediterranean and not a little of southern Italy. The backwardness in civilization of all of these regions that remained under Mohammedan rule is the answer of history to the insinuations of Gibbon and his imitators as to the benefits the Arabs might have conferred on humanity. Fortunately in the 8th century there came a division of the caliphates which greatly diminished Moham-

medan power and reunion never took place. The raising of the siege of Constantinople (718) was due more to one man, Leo, known as the Isaurian, than to any other factor. Leo was the son of a shoemaker who rose by military and administrative genius to be emperor and founded a dynasty. Like self-made men at all times he was confident that he could solve all problems since he had solved so many, and his interference in Church matters separated Christianity into two parts that in spite of many well-directed attempts have not united again. Leo and his son Constantine Copronymus declared against the worship of images in religion and encouraged the so-called iconoclasts or image breakers who did so much to disturb both religion and art in the East during this century.

Defeated in their attempts on Constantinople the Mohammedans forced their way along the northern shore of Africa, crossed the Straits of Gibraltar and succeeded in conquering Spain. In 711 they won a great victory over the Visigoths which made them masters of the country, and by the end of the first quarter of the century they had overrun the peninsula and were crossing the Pyrenees to menace Gaul. The Duke of Aquitaine held them in check for a time, but they defeated him near Bordeaux in 732 and advanced toward Tours. Between Tours and Poitiers their immense host was met by Charles Martel (the Hammer) and completely defeated in one of the decisive battles of history. There are few authentic details of the battle though it would seem to have been, as far as we know, the conflict with the greatest numbers engaged ever fought between men at any time in history except in our present Great War. Charles Martel was the mayor of the palace of the western Frankish king. The Merovingians had ruled since Clovis' time, but weaklings ascended the throne and the Prime Minister, who was called the mayor of the palace, became the real ruler. Charles' son Pepin, surnamed the Short, acquired even more power than his father and finally put to the Pope the question whether the king should reign when his power was gone, received the answer that it seemed better that he who had the power in the state should be king, and so Pepin began the Carolingian dynasty. Pepin was the father of Charlemagne who was destined to consolidate France, conquered the surrounding countries, including a portion of Spain from the Moors, put down the barbarians on the north and acquired dominion over northern Italy.

Charlemagne is the heart of the 8th century. The only man in history with whose name the adjective great has become so thoroughly incorporated that most people think of it as an essential part of his name, and he thoroughly deserves that distinction. At his accession Charlemagne's kingdom was the bulwark of the Christianity of the West. At his death his empire included most of western and southern Europe. Thought of usually as a warrior his greatness is reflected much more in his successful pursuit of a far-reaching constructive policy. He put an end to the process of political disintegration which had been at work in Europe since long before the fall of the Roman Empire, and he made it possible for men to think of

progress and civilization in place of being constantly occupied with resistance to barbarian aggression which for three centuries had been their one preoccupation. It was a fitting consummation of his work that he was crowned emperor of the Romans by the Pope at Rome on Christmas Eve of the year 800. It was a striking omen of the new outlook for Europe when in the first year of the 9th century and of the Imperial reign an embassy arrived with precious Oriental presents from the great caliph of the East whose name is as well known in history and romance as Charlemagne's own—Haroun al Raschid.

Charlemagne lives in romance through his expedition into Spain, whither he went to put an end to the menace of the Moors to his kingdom by attacking them in their own stronghold. After some years of war, begun at the instance of an embassy from Spain, in the year of the mystical number 777, he succeeded in conquering all the district north of the Ebro, and established there the Spanish March, a name given to outlying districts of his domain whose rule was committed to special officials called margraves, or counts of the marches, or marks, from which our word marquis. Charlemagne's defeat of the Moors was the first step in the gradual expulsion of the Mohammedans from Spain which was not to be accomplished in its entirety for over 700 years. On the return from his victorious expedition to Spain the rear guard of Charlemagne's army was attacked and cut to pieces by the Basques in the pass of Roncesvalles, in the Pyrenees. The battle of that name, fought by Roland and his Paladins with surpassing courage to the bitter end, was celebrated in song and story for many centuries afterward. The prodigies of valor there done tinged even the tales of chivalry which were to occupy so much Spanish attention in the later Middle Ages and whose influence was felt until Cervantes laughed the romances of chivalry away.

Charlemagne lives in history much more as a lawgiver, an organizer of the civil functions of his great empire and of education and opportunities for intellectual development than even for his success in arms. At his invitation Alcuin, called a Saxon monk by Charlemagne's earliest biographers, but claimed an Irishman (Albinus) by many writers, was invited to organize the schools all over Charlemagne's dominions. He was given the powers of Imperial Minister of Education. He well deserved Charlemagne's confidence. As Duruy says: "Alcuin was truly a scholar; he was familiar with Pythagoras; often cites Aristotle, Homer, Plato, Virgil and Pliny, and is one of the most noticeable instances of the union of those elements so difficult to harmonize, the spirit of ancient literature with the spirit of Christianity." It is interesting indeed to read of his founding in the palace of Charlemagne an academy in which the emperor and all his family and all the nobility at court were members. In this academy the emperor bore the name of David, Alcuin took the name of Flaccus, while other members took such names as Homer, Plato and Virgil. We have some 300 of his letters addressed by this modern Aristotle to the Alexander of the West.

Charlemagne's efforts for the provision of

education for his people included women as well as men. His own daughters as well as those of the nobility attended the Palace School, and there are letters of Alcuin which show that they were deeply interested in the intellectual problems of the time. The emperor also recognized the social obligations of the ruler and ordered that there should be hospitals in connection with all cathedrals and monasteries. At this time the word hospital included also refuges for the infirm, the old, the deformed and defective, and even the insane as well as for the homeless wayfarer.

In spite of many vicissitudes, wars, political disturbance and human incidental frailties, Charlemagne's work for civilization bore fruit down the generations, though his empire broke up and internal dissensions arose mainly through the custom of dividing the realm among his sons which Charlemagne also followed. He deserves such expressions as that of John Fiske: "When we think of all the work big with promise that went on in those centuries which modern writers in their ignorance used once to set apart and stigmatize as the Dark Age; . . . when we think of the various work of a Gregory, a Benedict, a Boniface, an Alfred, a Charlemagne, we feel that there is a sense in which the most brilliant achievements of pagan antiquity are dwarfed in comparison with these."

While Charlemagne was reigning gloriously in Europe at the end of the 8th century a ruler in many ways scarcely less worthy than he and equally famous, Haroun Al Raschid (Aaron the orthodox), occupied the Eastern caliphate. Haroun was the fifth of the Abbassid caliphs, an accomplished scholar, a poet of distinction, who gathered wits, poets and musicians around him. It is for this reason that he is so widely and favorably known for it is to the Arabian Nights rather than to history that his fame is due. How much of the real greatness of his reign was due to Yalya, his vizier of the Barmecide family, is difficult to say. Haroun's personal character is revealed by his murder of his sister and his nephews when he learned of her marriage to the brother of his vizier. While all his life he occupied a position of bitter hostility to the Greek emperors, there is a well-established tradition that he sent presents to Charlemagne and endeavored to cultivate his friendship though perhaps only with the idea of thus making less of the rulers of the Eastern Empire.

Europe had freed herself from the danger of Mohammedanism attacking from the east and South, but before the end of the century was to witness an invasion of almost more serious nature from the opposite quarter. The Vikings or Norsemen invaded Britain in the last decade of the century and were to prove a serious foe to civilization for the next three centuries in many countries of Europe. Britain and Ireland had succeeded in developing education and culture, and Gaul had made a magnificent beginning under Charlemagne, but the Danes were to prove a serious detriment and obstacle. Alfred overcame them in the next century for a time in Britain, but the northern coast of France had to be given over to them and they obtained a foothold in Sicily and southern Italy. They represent a much more

serious impediment to the evolution of civilization at this time than any internal factor.

The 8th century was the scene of the career of one of these men who, forgetting themselves in life, are never willingly forgotten. This was Boniface, the apostle of Germany. His name was Winfrid (A. S., "win-peace"), and he received the surname of Bonifacius from the Latin signifying "good face or the benevolent." Born of noble parents in Devonshire, England, he insisted on devoting himself to the spiritual and intellectual life in a monastery at Exeter, and when his talents assured his advancement, he obtained permission to become a missionary to the old Saxons. Some 40 years were spent in missionary labors, and Boniface has been in honor ever since as the apostle of civilization as well as of Christianity to the German people. Distinction came to him unsought and Boniface was made a bishop and subsequently archbishop of Mainz and primate of Germany. Having solved some of the serious problems of ecclesiastical jurisdiction by his genius in the management of men as well as his kindness of disposition he gave up his archbishopric to become a missionary to the Frisians by whom he was put to death. His letters which have been preserved show us the interests of the time better, perhaps, than almost any other set of documents of the period that we possess.

One of the most interesting of Boniface's developments in Germany was his invitation to English nuns to help him in his mission. He recognized that the German women still swayed that influence in the communities which has been described by Tacitus and realized that women auxiliaries would be of great help on the mission. Thecla and Lioba, to whom the title of Saints has been accorded, accepted this invitation and exercised great influence. Boniface's letters show how thoroughly he appreciated the nuns as intelligent fellow-laborers in his apostolate. The education of the children of the Germans was confided to them and a greater influence was thus brought to bear on the Teuton women than could otherwise have been exercised. It was to the rising generation that Boniface looked for the exhibition of genuine Christianity for it had proved extremely difficult to bend the savage natures of the Germans to the milder virtues of the Gospel. Saint Thecla particularly did much to organize the rising generation of young German women to carry on her missionary work.

The 8th century is usually considered one of the low periods of intellectual life in history and yet it contains the careers of three men famous ever after for their intellectual work. The greatest of these is undoubtedly the man who, within two generations of his death, came to bear the title of Venerable Bede, by which he has been known ever since. Something of the place that he secured for himself in Christian scholarship will probably be best appreciated from the fact that in November 1899 Pope Leo XIII decreed to him the title of Doctor of the Church. Bede's influence was very great in his own time, not only in England but throughout all of western Europe, and in spite of the incursions of the Danes which disturbed English Christianity and its influence so

much, Bede's work came to be widely known. He has come to be recognized as the greatest scholar of his time—a writer whose style and critical judgment have made him a favorite author even in modern times. With a literary propriety seldom exhibited in his time he referred all his materials to their sources and insisted on copyists giving all the references. His critical, historical judgment has given him a distinct place among the historians. His life was a round of study and prayer with occasional visits for a few days to friends and is the ideal scholarly writer's life at all times. The surprise is to find it so well exemplified in the England of the first half of the 8th century.

The second of these great scholars, John of Damascus, or Saint John Damascene, also had the distinction of being enrolled among the Doctors of the Church by Pope Leo XIII. His intellectual distinction is that of being the first of the scholastic philosophers and his 'De fide orthodoxa' is often hailed as the first work of scholasticism. He undoubtedly had a deep influence upon the Arabian scholars of his time, and their philosophy owes much to his inspiration for they admired him as much as his Christian colleagues. The most important of his works is that one known as the 'Fountain of Wisdom.' It has a special significance in the history of theology because it is the first attempt at a *Summa Theologica* that has come down to us, though there were to be many such in all the centuries of the Middle Ages afterward. Damascene's work for the Church is due to Leo the Isaurian's attempt to be head of both Church and state and dictate the beliefs of his people in the matter of the veneration of images. When Leo issued his first edict, John was chief councillor of the city of Damascus and not a cleric, but he took up the defense of Church traditions, and then, recognizing his lack of knowledge for Christian apologetics, he entered a monastery, gave himself to study and became the great leader of the Christian thought of the time. He suffered bitter prosecution at the hands of the emperor and his satellites, but he was vindicated by the Seventh General Council of Nice (787) and came to be known after the Greek fashion of adding a title of admiration as John Chrysorrhoeas, that is, "John of the Golden Stream," because of his golden flow of words in defense of Christianity. Damascene is besides one of the world's great writers of hymns, and modern hymnologists have even spoken of him as the prince of Greek hymnodists. Three of his hymns, 'Those Eternal Bowers,' 'Come, Ye Faithful, Raise the Strain' and 'Tis The Day of the Resurrection,' are widely known and admired in their English version.

The third of the scholars of the 8th century whose name is often still mentioned was Vergilius, bishop of Salzburg, who had been an Irish missionary of the name of Fergal or Fergihl. He was received with great favor by Pepin, then mayor of the palace, and his talents and learning led to his being made abbot of Saint Peter's at Salzburg. He was deeply interested in mathematics and astronomy and his teachings that there were antipodes led to his being tried in the ecclesiastical courts, not, however, because of the scientific doctrine,

but because it was said that this involved the denial that men had all come from a single origin. Vergilius succeeded in showing that his teaching was not contrary to Scripture and it was after this that he was made bishop of Salzburg. He was canonized in the 13th century by Gregory IX. There seems no doubt that his belief in the existence of people on the other side of the earth and that the earth itself was a sphere was due to his knowledge of the accounts of some of the Irish expeditions that had probably found their way in times of storm if not voluntarily across the Atlantic.

The century closed with a woman, Irene, the only woman who ever occupied the position of empress, in the fullest sense of the word, Basileus, in the Eastern Empire. While she had taken a determined stand against the Iconoclastic party which was disturbing both Church and State, she is distinctly one of the least worthy rulers of history. French historians have not hesitated to declare that she was as given to intrigue as Catherine de Medici, and spared not even her own son in her ambition. She schemed against his marriage to Rotrud, a daughter of Charlemagne, and forced him to marry an Armenian totally unsuitable to become his consort. She sanctioned his bigamy with a woman of the court in the hope of ruining his career, and is even said to have blinded him before confining him to prison where he died. She did not long enjoy the fruit of her ambition (797-802), but was deposed by Nicephorus and passed the end of her life on the island of Lesbos in poverty and contempt.

The Pope and the people of Rome took advantage of the accession of Irene as the formal empress to repudiate the Eastern Empire and to make a formal break with Constantinople. They declared that a woman could not be Cæsar and Augustus, and thus the path was laid open for a new era and a Western Empire. Pepin, as king of France, had come at the request of Pope Stephen III to save Italy from the Lombards, and was hailed as ruler though he received only the name of patrician which Charles inherited from him. This office was changed to that of emperor, and Pope Leo crowned Charlemagne as emperor in the last days of the 8th century.

JAMES J. WALSH,

*Author of 'The Thirteenth the Greatest of Centuries.'*

#### PRINCIPAL EVENTS OF THE 8TH CENTURY.

710. The Saracens conquer Spain.
714. Charles Martel, natural son of Pepin the "major domo," or chief of the Franks, succeeds his father.
719. Boniface of England begins his civilizing mission in Germany.
721. The Saracens invade France.
726. Leo the Isaurian interdicts the worship of images.
731. Bede the Anglo-Saxon scholar completes his great work 'Historia Ecclesiastica Gentis Anglorum.'
732. Charles Martel defeats the Saracens at the Battle of Tours, and compels their retreat to Spain, which they almost entirely occupy, driving the Goths to the Asturias.
- 737-741. Charles Martel, having also subjected several German tribes, becomes duke and prince of the Franks.
752. Pepin the Short, son of Charles Martel, succeeds him and is made King of the Franks.
754. Constantine V of the Eastern Empire suppresses monasteries.
755. Archbishop Boniface, apostle of Germany, is murdered by pagan Frisians at Dokkum.
756. The Lombards of Baltic origin, occupying the north of Italy, are defeated by Pepin, son of Charles Martel and father of Charlemagne.
768. Charlemagne begins to reign in Western Europe.

774. Charlemagne conquers the Lombards; and Upper Italy is ruled by the Franks; Middle Italy by the Pope; Lower Italy by the Greeks.  
 777. Charlemagne invades Spain.  
 778. The battle of Roncesvalles.  
 782. Northmen invasion of England and massacre of the Saxons.  
 787. The Danes establish themselves in England.  
 794. Charlemagne holds a great Council at Frankfort.  
 795. Pope Leo III is acknowledged first bishop of the West.  
 797. Irene begins her short reign as Empress of the East.

**EIGHTH NERVE.** See AUDITORY NERVE.

**EIKON BASILIKE**, i'kōn ba-sil'i-kē (Gr. 'the royal image'), a work the full title of which is *Εἰκὼν βασιλική*: 'The Pourtraicture of His Sacred Majesty in His Solitudes and Sufferings.' It was published 9 Feb. 1649, 10 days after the execution of Charles I, and within 12 months ran through 50 editions in various languages. It professes to be Charles' own composition in the form of a diary. It is written in an affectedly dignified strain, and contains numerous assertions of love for his misguided and ungrateful people. At the Restoration, Gauden, afterward bishop of Worcester, laid claim to the authorship, and a memorandum in the copy of the Earl of Anglesea, lord privy-seal under Charles II, affirms that claim with the authority of Charles II and the Duke of York. Milton's answer to it, 'Eikonoklastes' (that is, 'imagebreaker') appeared the same year by order of Parliament. Gauden professed to have begun the work in or about the year 1647, and to have submitted a MS. copy of it to the king. On the other hand, those who maintain that the work was by Charles, assert that he had written the first six of its 28 chapters before the battle of Naseby (1645). The question is one of much complexity. Historians generally, from Lingard to Green, have pronounced against Charles; while some of those who have sifted his claims are in his favor. (See GAUDEN, JOHN). Consult Almack, 'Bibliography of the King's Book' (1896); Doble, in the 'Academy' (1883); Scott, E. J. L., 'Comments in Edition of the Work' (1880); Wordsworth, Christopher, 'Who Wrote Icon Basilike?' (1824-25); Tucker, 'On the Author of Icon Basilike' (Berlin 1874).

**EILDON**, ēl'dōn, **HILLS**, three peaks belonging to a single mass, south of Melrose, in Roxburghshire, Scotland. The highest attains an elevation of 1,385 feet above sea-level, and all command a splendid prospect and are rich in historic and legendary associations.

**EILENBURG**, i'lēn-boorg, Germany, town of Prussian Saxony, in the government of Merseburg, mainly situated on an island of the Mulde, 14 miles northwest of Leipzig. It has manufactures of calico, woolen cloth, yarn, dyestuffs, vehicles, basketwork, tobacco, chemicals, celluloid, beer and agricultural implements. Franz Abt, the song writer, and M. Rinckart, the poet, were born here. Pop. 17,401. Consult Gundermann, 'Chronik der Stadt Eilenburg' (Eilenburg 1879).

**EILETHYIA** (hieroglyph, *Nekheb*; city of Lucina, now called EL-KĀB), a city of ancient Egypt, situated on the right bank of the Nile, a little below Edfu. The present ruins consist of the remains of small temples dedicated by Ramesses II to Ra; a Ptolemaic temple dedicated to the eponymous goddess Lucina by Physcon or Euergetes II, with additions by Ptolemy Alexander I and the elder Cleopatra; and an ancient

temple dedicated by Amenophis III to the local deities. The names of other monarchs are also found in the ruins; but the most interesting and important remains are the rock-tombs, some as early as the 13th dynasty, excavated in the hills. That of Aahmes, the "captain of the sailors," records his services in the wars of the early monarchs of the 18th dynasty against the Hyksos or Shepherds, and other Asiatic and Nigritic races. Another, that of Pahir, is decorated with rich and elaborate paintings, representing the pursuits of agriculture, fowling, fishing, etc. The city was an outpost against the southern tribes, and its fort, a large enclosure of crude brick, was of importance as early as the Shepherd War. The goddess Suben (Eilethyia or Lucina) was a special protectress of Upper Egypt. Consult Brugsch, 'Reiseberichte' (Leipzig 1855), and 'Egypt Under the Pharaohs'; Wilkinson, 'Ancient Egyptians'; Mariette, 'Ancient Egyptian History'; Quibell, 'El Kab' (London 1897).

**EIMBECK**, im'bēk, **William**, American geodesist: b. Brunswick, Germany, 29 Jan. 1841. He was for two years professor of mechanics and engineering, Washington University, and a member of the government solar eclipse expeditions to Illinois 1869 and to Italy 1870. After 1871 he was an assistant on the United States Coast and Geodetic Survey. He has been a Fellow of the American Association for the Advancement of Science since 1879, and is the inventor of the invariable reversible pendulum and the duplex base apparatus of coast and geodetic survey. His chief work has been in connection with the western divisions of the 39th parallel triangulation across the continent.

**EINBECK**, in'bēk, or **EIMBECK**, Germany, town of Prussia, in the province of Hanover, on the Ilme, near its junction with the Leine, 40 miles south of Hanover. In the Alexander-kirche are remarkable old choir stalls, a bronze baptismal font of exquisite design and the tombs of the Prinzen-Grubenhagen. The town has vocational departments attached to its school system and maintains a school for police. Belts, linen, carpets, felt, sugar and tobacco are the principal articles of manufacture. The formerly celebrated Einbecker bier ("bock" beer) is still made here. Einbeck was a place of importance in the 15th century. It was a member of the Smalkaldic League and it figured prominently in the Thirty Years' and the Seven Years' wars. There are still remains of its old walls and towers. Pop. 9,431.

**EINHARD**. See EGINHARD.

**EINHORN**, in'hōrn, **David**, American rabbi: b. Dispeck, Bavaria, 10 Nov. 1809; d. New York, 2 Nov. 1879. His first rabbinical position was at Hopstadten, Bavaria, and shortly afterward he became chief rabbi of the grand duchy of Mecklenburg-Schwerin. In 1851 he was called to Pesh, but his progressive tendencies aroused sharp opposition and his temple was closed by order of the government. In 1855 he was invited to become rabbi of the Har Sinai Congregation, of Baltimore, Md. His activity was now to be rapidly developed, for he issued his prayerbook, which was warmly received by many reformed Jewish congregations, and he began the publication of a scholarly monthly magazine in German, entitled *Sinai*, in the interests of advanced reform.

His vigorous onslaughts on slavery in 1861 led to his removal from Baltimore to Philadelphia, where he became rabbi of the Keneseth Israel Temple and published his catechism. In 1866 he was elected rabbi of the Adath Teshurun Temple in New York, where he continued a zealous, impassioned and scholarly advocate of reform and the leader of the then radical school, until his retirement in July 1879.

**EINSIEDELN**, in'zē dēln, Switzerland, (place of the solitaries or hermits), a small town in the canton of Schwyz, 2,895 feet above sea-level and 26 miles southeast of Zürich, seat of a renowned abbey of Benedictine monks since the middle of the 9th century. It is a famous resort of pilgrims who visit the place in thousands to venerate an ancient miraculous image of the Blessed Virgin. For the accommodation of the pilgrims the little town has more than 50 inns or houses of entertainment. Those pilgrimages are made throughout the year, but the great annual pilgrimage culminates on the anniversary of the dedication of the abbey's church, 14 September. The present abbey is the successor of four previous edifices which were destroyed by fire; it was erected in the first quarter of the 18th century and is an imposing pile in the Italian style. The place was visited by Edward Gibbon, the historian, 1755, who writes that he was "astonished by the profane ostentation of riches in the poorest corner of Europe; amidst a savage scene of woods and mountains a palace appears to have been erected by magic and it was erected by the potent magic of religion." The abbey which Gibbon then saw is still in existence and is annually visited by more than 150,000 pilgrims. It was plundered of its vast treasure of silver and gold and precious stones by the French (1798), but it is still very rich, especially in literary monuments, possessing a library of 61,000 volumes, 1,190 manuscripts and more than 1,000 productions of the printing press in its early period. The leading industry is the manufacture and sale of religious objects, statues, crucifixes, altar vessels, etc. The monastery has many historical and religious associations; a great chandelier was donated by Napoleon III. The monastery was founded by Meinrad, who built a lady chapel here to house the statue of the Virgin given him by Hildegard. Pop. 8,438. Consult Ringholtz, O., 'Geschichte des fürstlichen Benediktinerstiftes Einsiedeln' (Einsiedeln 1904).

**EISELEN**, i'zē-lēn, **Wilhelm Bernard**, German gymnast: b. Berlin, 27 Sept. 1792; d. Misdroy, 22 Aug. 1846. His early studies began in Berlin and he was the pupil of the eminent gymnast Jahns. He soon became prominent among the young gymnasts of Berlin and in 1819 began to teach gymnastics at a school in Berlin. He opened a fencing school in 1825 in Berlin and a gymnasium in 1828, and had a vast number of pupils. The first gymnasium for young girls was instituted by him in 1832. He published many works on gymnastics and fencing, including 'Deutsche Turnkunst' (in collaboration with Jahn, 1816); 'Abriss des deutschen Stossfechtens' (1826).

**EISENACH**, i'zē-nāh, Germany, town in the grand duchy of Saxe-Weimar, at the north-west end of the Thuringian Forest, at the confluence of the Nesse with the Hörsel, 17 miles

west of Gotha. The neighborhood is remarkably picturesque, being ornamented with splendid gardens and residences. In the marketplace there is a monument to the memory of those from the neighborhood who fell in the war of 1870-71, and in the Karlsplatz stands the Luther memorial, unveiled in 1895. It contains many old buildings of historical and architectural importance. Among the educational institutions of Eisenach, the most prominent is the gymnasium formerly a Latin school, which Luther and Bach once attended, a school of forestry, a school of design and a teachers' seminary. It has some well-developed manufacturing interests which comprise coloring materials, white-lead, woolens, beer, leather, pottery, tobacco, cigars, cement pipe, alabaster ware, cabinet-work, lumber, oil, machinery, etc. The town has many interesting historical associations. Luther was at school here, and Sebastian Bach, to whom there is a statue, was born here. Near it is the Wartburg, where Luther resided for a time for safety. Eisenach was formerly the capital of a principality of the same name. Consult Scheller, 'Eisenach und Umgebung,' ed. by Kühner (Eisenach 1898). Pop. 38,362.

**EISENACH CHURCH CONFERENCE.** See EVANGELICAL CHURCH CONFERENCE.

**EISENBERG**, i'zēn-bērg, Germany, town in the province of Saxe-Altenburg, of great antiquity, birthplace of the philosopher Krause, whose statue is set up there. It is near the junction of the Saale and Elster, 36 miles southwest of Leipzig. It possesses a famous castle, Christiansburg, and is the seat of many manufactures, including woolens, velvet, pottery, furniture, pianos, porcelain and agricultural machines. Statues have been erected to Bismarck and to Duke Christian of Saxe-Eisenberg, in addition to that of the philosopher Karl Friedrich Krause. Pop. 10,749. Consult 'Chronik der Stadt und des Amtes Eisenberg' (Eisenberg 1843).

**EISENERZ**, i'zēn-ertz, Austria, mining town in the north of Styria, 20 miles northwest of Bruck. It stands in a narrow mountain valley at the foot of the Erzberg (5,000 feet), a mountain so rich in iron ore that the miners, instead of cutting mines into it and following the metal in veins, quarry the rock from the outside. About 5,000 miners are employed in the quarries on the mountain in summer and 2,800 in winter, the annual output being about 1,000,000 tons, of which about 40 per cent is metal. The Gothic church of Saint Oswald, founded in 1279, is an excellent example of the fortified type of ecclesiastical architecture. Aragonite of the purest white, and resembling coral branches in form, and of the most beautiful white is found in caves in the mountain. Pop. 6,494.

**EISENMENGER**, i'zēn-mēng-ēr, **August**, Austrian fresco painter: b. Vienna, 11 Feb. 1830. He studied in the Vienna Academy and early gained the first prize in drawing (1845). In 1863 he was appointed teacher of drawing in the Protestant Real-schule of Vienna. His first work of importance was the fresco which he executed in the hall of the Society of Musical Amateurs (*Musik Freunde*), 'Apollo with the Muses'; but he has painted many notable frescoes in other public buildings. He was

appointed professor of the Vienna Academy in 1872, remaining until 1901, and at the same time opened a private school of fresco painting. His more important works included the frieze medallions in the Museum of Art and Industry, Vienna; a series of historical pictures illustrative of the reign of Emperor Maximilian I, in Castle Hörnstein, near Vienna (1872-79), and the decorative painting in the session room of the Chamber of Deputies in the Reichsrat building at Vienna (1885).

**EISENSTADT**, ɪ'sɛn-stāt, or **KISMARTON**, Hungary, town in the County of Odenburg, at the foot of the Leitha Mountains, and 25 miles southeast of Vienna. It contains the magnificent palace of Prince Esterházy, erected in 1683 and restored in 1805. Fine grounds surround the palace, in the library of which is housed a fine collection of musical manuscripts. Nearby is the pilgrim shrine of Maria-Einsiedel, also the burial place of the composer Joseph Haydn. Pop. 3,073.

**EISLEBEN**, is'lā-bɛn, Germany, town in Prussian Saxony, 18 miles to the west of Halle, famous as the place where Martin Luther was born and died. The royal gymnasium, originally founded by Luther, was rebuilt in 1883. The house in which Luther died has been recently restored. In 1883, on the occasion of the celebration of the 400th anniversary of Luther's birth, a statue of him was unveiled in the market-place. In the church of Saint Andrew are busts of Luther and Melancthon, the tombs of the counts of Mansfeld, and Luther's pulpit. Other Lutheran relics are in the church of Saints Peter and Paul. Copper and silver are mined in the neighborhood of Eisleben, which has several smelters. A considerable trade in flower and vegetable seeds is carried on. In the 10th century the place was called Islebin. Soon after the year 1100 it fell to the counts of Mansfeld, in whose possession it remained until 1780, when it was given to Saxony. In 1815 it was transferred to Prussia. Pop. 24,629.

**EISTEDDFOD**, i-stɛt'vɔd, the name of an assembly of Welsh bards for the purpose of musical and poetical contests. They were held at different places for the minstrels of their respective neighborhoods; two noted ones were held at Caerwys, at Aberfraw in Anglesea and at Mathravel in Powys. The judges were appointed by commissions from the native princes, and, after the conquest, from the English kings. The last was issued in 1568 by Queen Elizabeth, but the ancient custom has been again revived by the Gwynedigion and Cambrian societies, and annual meetings for the recitation of prize poems and performances on the harp are now held under the name of Eisteddfod. The Eisteddfod proper was announced a year and a day beforehand at an assembly called a gorsedd, at which prizes for the previous competition were awarded. At the present time yearly eisteddfods are held alternately in the north and south of Wales, and in some parts of the United States, especially throughout Pennsylvania, and other sections settled by the Welsh people. Annual meetings take place, in every way similar to the rite in their native land. During the Columbian Exposition at Chicago probably the

most notable Eisteddfod held in this country took place there.

**EJECTION AND EVICTION.** Ejection in law is a mixed action, as it is resorted to in order to recover the possession of land and damages for the wrongful withholding of it, though the damages are nominal. Originally, it was a possessory action—that is, adapted to the recovery of the possession of land. It ultimately became a convenient means of testing the title by a series of fictions. The supposition was (and this was the substance of the fiction) that a lease for a certain number of years had been made to a tenant, "John Doe," who had entered into possession and had been ejected by a person supposed to represent the party to be finally made defendant. This person was called "a casual ejector," and was usually represented as "Richard Roe." An action was then brought, substantially under the following title: "Doe, as tenant of Edwards (claiming the land), against Roe." A written notice was thereupon sent in the name of Roe by Edwards' attorney to the opposing claimant (Jones), who is the person in possession. By this notice Jones was advised to defend the action, otherwise Roe would permit judgment to be taken against him, and the possession would be lost. Jones, on making application to be made defendant, was allowed to defend on condition that he would admit the validity of the fictitious portion of these proceedings, so that the matter was narrowed down to a trial of the merits of the case. The action was now deemed to be between Edwards and Jones, although Doe still remained plaintiff on the records of the court. It was a rule in this action that the plaintiff can only recover upon a legal title, as distinguished from a title in a court of equity. He can succeed upon the strength of his own title, and of its validity, and not upon the weakness of that of his adversary. He must also have a right of entry. Where that does not exist another form of action must be resorted to. This method of procedure was defective in one particular. Any number of successive actions of ejection could be brought by the plaintiff, although he had been defeated. The only check upon actions of this kind was a resort to a court of equity for an injunction to prevent harassing litigation. In England the fictitious portion of the proceeding was abolished by the Common Law Procedure Act of 1852, and the action placed upon satisfactory grounds. In New York and some other States the same result had been accomplished as early as 1830. In 1875 the law in England was modified to the extent of making an action for the recovery of land similar to other actions, all of which were simplified to conform to a unified plan. This legislation was copied by many States of the Union, but in many jurisdictions the ancient forms survive. In general, it may be stated that an ejection action may be brought by any person having a legal right to possession, whatever be the character of his interest in it against any person or persons who wrongfully hold it against one having an estate therein. Title must be proven by the plaintiff. Substantial damages to the plaintiff are now allowed in most jurisdictions. Consult Blackstone, 'Commentaries on the Laws of England'; Stephen,



'New Commentaries' (1903); Powell, 'The Law of Ejectment' (1911).

**Eviction.**—Depriving a person of his lands or tenements. Technically, the dispossession must be by judgment of law; if otherwise it is an *ouster*. Eviction may be total or partial. Total eviction takes place when the possessor is entirely deprived of his rights in the premises. Partial eviction takes place when the possessor is deprived of only a portion of them, as if a third person comes in and ejects him from a portion of his land, or establishes a right to some easement over it, by an older title than that under which he holds. See **DISPOSSESS**.

**EKATERINBURG**, é-kā'tè-rén-boorg', or **IEKATERINBURG**, Russia, town, in the government and 170 miles southeast of Perm, on the east side, and in the mining district of the Ural Mountains. It was founded in 1723 by Peter the Great and was named after Empress Catharine I. It has a mint, arsenal, custom-house, mining-school, hospital, meteorological observatory and botanic garden. The art of cutting, polishing and engraving gems, which are found in the neighboring mountains, is here carried to great perfection, and, together with mining and metallurgy, and a commerce in cattle and cutlery forms the chief occupation of the inhabitants. In the neighborhood are several platinum mines and also the famous gold mines of Beresov and Niviansk. Pop. 52,230.

**EL BRACITO** (N. M.), Battle of (Doniphan's name BRAZITO, Mexican TEMASCALITOS), 24 Dec. 1846, in the Mexican War. Colonel Doniphan, marching from California to Chihuahua, was assailed at a bend of the Rio Grande, some 25 miles from El Paso, by a battalion of Mexicans under Antonio Ponce. The Mexicans fired at long range as they charged; the Americans waited till they came close, then broke them with a destructive volley, and a company of 20 horse scattered their cavalry, which fled to the mountains. American loss, 7 wounded; Mexicans, 43 killed and 150 wounded.

**EL BURLADOR DE SEVILLA.** Tirso de Molina's drama, 'El Burlador de Sevilla y Convidado de Piedra' ('The Gay Scoffer of Seville and Feast of the Statue'), is the parent source in literature of the famous legend of Don Juan Tenorio, the unscrupulous gallant and blasphemer, subsequently presented variously by Molière and Byron as Don Juan, by Mozart as Don Giovanni, and, in Spain itself at a more recent date, by José Zorilla as Don Juan Tenorio in the most popular of all Spanish plays. Few characters in the history of letters have attracted the attention of so many writers of genius, or have been reproduced so universally and in such multiplicity of styles. In itself, however, Tirso's play is a structureless aggregation of amorous adventures, in the course of which the hero seduces a Neapolitan lady, a fisher-girl, a young peasant, and, by a base deception, Doña Ana de Ulloa, whose father he slays. The blasphemous feast which follows, at which the statue of the Commander Don Gonzalo de Ulloa dines with Don Juan, dragging him down afterward with the tomb from which it has descended and the chapel containing it to perdition, is wholly distinct

from the other episodes, which Tirso conceives after the manner of the chronicle play in a succession of loosely related incidents, without regard either to consistency of character or to dramatic action. His Don Juan is a mere vulgar seducer, by after-thought a blasphemer, whose overthrow does not rise above the sphere of melodrama. Although Tirso must be held to rank with Lope de Vega and Calderón at the head of the Spanish romantic theatre, even the pastoral elements in this play are devoid of picturesqueness and lack the author's customary mellowness and sober imaginative charm. The story had been utilized previously by Juan de Cueva. While of uncertain origin, prevailing Spanish authority traces it to Seville, where Don Juan Tenorio is said to have died at the foot of the statue of the Commander, whom he had killed, as in the play. The Feast of the Statue is derived from independent sources. The play was first printed in 1630, but has never been translated into English. Consult Cotarelo y Mori, E., in his introduction to the 'Obras de Tirso de Molina' (in the *Nueva Biblioteca de Autores Españoles*, Vols. IV and IX, Madrid 1906-07); Menéndez Pidal, R., 'Sobre los orígenes de El Convidado de piedra' (in *Cultura Española*, Madrid, May 1906).

JOHN GARRETT UNDERHILL.

**EL CANEY**, ēl kā'nā, Cuba, town, on the main road, four miles northeast of Santiago de Cuba. During the Spanish-American War it was the scene of a battle between 525 Spaniards under General Vara del Rey, and 4,400 Americans under General Lawton. The Spaniards made a desperate resistance, but were finally overcome by the American infantry. The Spaniards lost 320, and 100 were taken prisoners; the Americans lost 440. This battle occurred 1 July 1898. In 1901 the United States government purchased the battlefield and approaches for a public reservation. See **UNITED STATES—SPANISH-AMERICAN WAR**.

**EL DORADO.** See **ELDORADO**.

**EL DORADO**, Ark., city and county-seat of Union County, 30 miles southeast of Camden, on the Chicago, Rock Island and Pacific, the El Dorado and Wesson, and the Saint Louis, Iron Mountain and Southern railroads. It has cotton oil and planing mills, railroad repair shops, an iron foundry and bottling works. It contains also a courthouse and a county jail. In 1908 it was chartered as a city. The surrounding district is devoted to cotton and peach growing. Pop. 4,202.

**EL DORADO**, Kan., city, county-seat of Butler County; on the Walnut River; the Atchison, Topeka and Santa Fé, the Missouri Pacific, and other railroads; about 25 miles east of Wichita. The city is situated in a rich agricultural region, and its principal trade is in grain, livestock and farm and dairy products. The city has machine shops, wagon works and quarries of limestone. It was settled in 1858 and was first incorporated in 1870. The city has a Carnegie library, and the water supply system is the property of the municipality. Pop. 3,129.

**EL GRAN GALEOTO.** José Echegaray's 'The Great Galeoto,' certainly the most famous Spanish play of the 19th century beyond the

limits of Spain, and the work upon which the international reputation of its author is founded, is an exceedingly effective example of the traditional Calderonian drama of jealousy, in which the honor of the husband is attacked by a peculiarly insidious enemy. Gossip here becomes the Galeoto, or go-between, which unites the lovers, the use of the title having been suggested by its appearance in the episode of Francesca in the fifth canto of Dante's 'Inferno,' where it has reference to the relations of Galahad (Galeoto) with Lancelot and Guinevere. Echegaray is an adept in stage effect, yet his drama is never deficient in a certain weight and dignity which, when tempered with restraint as in this play, impart to his fervid emotionalism a distinction uncommon in the theatre of his time. These qualities, together with a faculty for realistic detail, have led foreign critics to regard him as a psychologist, and the play as a study of the effects of gossip on the lives of innocent persons, who are influenced by its suggestions to their ultimate ruin. From this point of view, however, the work is curiously incomplete and unsatisfying; in Spain it has been recognized since its appearance in 1881, as an excellent stage play, which conforms only superficially to the canons of Ibsenism. The mediocre verse of the original has diminished its popularity and importance of late years upon the Spanish-speaking stage.

The best English translation is that by Eleanor Bontecou, included in 'Masterpieces of Modern Spanish Drama' (New York 1917). Other versions are by Hannah Lynch (London 1895), and by Jacob S. Fassett, Jr., (Boston 1914). 'The World and His Wife,' a free adaptation made through the German, has been played widely throughout England and the United States. For criticism of Echegaray, consult Bueno, Manuel, 'Teatro Español contemporaneo' (Madrid 1909).

JOHN GARRETT UNDERHILL.

#### EL-KHARGEH. See KHARGEH.

**EL PASO**, *el pa'so*, Texas, city, port of entry and county-seat of El Paso County; on the Rio Grande, the Atchison, Topeka and Santa Fé, the Texas and Pacific, the Rock Island, Southern Pacific and other railways; on the Rio Grande River in the extreme western part of the State. It is opposite Ciudad Juarez, Mexico, the north terminus of the Mexican Central Railway. El Paso is about midway between the tide water of the Atlantic (Gulf of Mexico) and the Pacific oceans, about 3,800 feet above sea-level and is central to the rich tributary regions of western Texas, New Mexico, Arizona and the northern section of old Mexico; it is 600 miles from any railroad centre that may compete with it. It is the centre of a rich fruit and vegetable growing region, the great Elephant Butte Dam (q.v.), costing nearly \$10,000,000, furnishing ample water for irrigation. By it 200,000 acres are reclaimed. El Paso's unequaled railway facilities, the proximity in New Mexico of inexhaustible supplies of fuel coal and the demand for supplies and machinery from the mines, ranches and growing towns of its neighborhood make it one of the most important manufacturing cities of the Southwest. Its most important industry is smelting the valuable ores of the neighboring region. The El Paso smelters have a capacity

of about 40,000 tons of ore a month. The monthly payment to miners for ores brought in averages nearly \$2,000,000, a large part of which finds its way into the stores and factories of the city; the monthly pay-roll of the smelters and other manufactories and the railroads centering in the city is nearly \$300,000; and these together give to the financial interests a stability that is little affected by conditions in other parts of the country. It has one of the largest custom smelters in the world, giving employment to from 2,500 to 3,000. Other industrial establishments are a wood-finishing and box factory, foundries and machine shops, cement plant, railroad repair shops, brick and tile works, sash and door, macaroni and cigar factories, brass works and flour mills. The United States Census of Manufactures for 1914 showed within the city limits 117 industrial establishments of factory grade, employing 2,815 persons, 2,347 being wage-earners, receiving annually \$1,663,000 in wages. The capital invested aggregated \$8,666,000 and the year's output was valued at \$6,135,000; of this, \$3,262,000 was the value added by manufacture. Many eastern manufacturers, especially of machinery, have large warehouses here. The city carries on an extensive trade in copper, silver and lead, machinery, livestock, wool and hides and has important wholesale and jobbing interests. El Paso has 10 national banks, with resources amounting to over \$27,660,719, and deposits over \$22,660,485, as contrasted with \$1,500,000 and \$750,000 respectively 30 years ago. El Paso is pre-eminently a city of homes. The streets are lighted by gas and electricity, and a well-planned electric street-railway system places all parts of the city within easy reach of the business section. The more notable buildings are the Federal building, county courthouse, city hall, post-office, high school, the State School of Mines, Fort Bliss, Carnegie library, Knights of Columbus Home, Masonic Temple. There are 13 public parks. The city has several public schools and parochial (Roman Catholic) schools, a business college, and is the seat of the Saint Joseph's Academy and of the Rio Grande Congregational Training School and Theological Seminary. There are several handsome churches and two well-equipped hospitals. El Paso is a noted health resort, having many excellent hotels, some of which are open during the entire year. The assessed valuation in 1916 amounted to \$48,736,645. There are within the city limits nearly 60 miles of asphalt streets, 82 miles of concrete sidewalks and 97 miles of sewers. The city adopted the commission form of government in 1907. Its receipts amount annually to about \$2,000,000, while its payments reach about \$1,800,000. The waterworks system, costing \$1,500,000, is owned by the city. The Spanish explorers visited the site at an early time. The first settlement was made in 1827, and the town incorporated in 1869. During the Civil War it was occupied alternately by Federal and Confederate troops and for a time was the base for operations against New Mexico and Arizona. The present charter dates from 1889 with revisions of 1891 and 1907. El Paso has grown more rapidly than any other city in Texas or the Southwest. The city has had no boom, its increase being healthy and substantial, and in accordance with the demands of commerce and

the development of the natural resources of the country tributary to the city. The total imports in 1915 had an appraised value of \$9,149,410, of which cotton, cattle, copper, silver, zinc and lumber formed the principal items imported. Exports were valued in 1915 at \$6,146,655, of which coal and coke, shoes, bleached cotton and cotton prints comprised the bulk. Pop. 70,700.

**EL RENO, Okla.**, city and county-seat of Canadian County; on the Rock Island Lines, junction main lines north and south, and east and west, being operating headquarters for the second district of the system; terminal for Saint Louis, El Reno and Western Railway, and also for Oklahoma Railway Company—Interurban. Near the geographical centre of State, it exploits a rich agricultural district producing alfalfa, corn, kafir, wheat, oats, broom corn, fruits and vegetables. The industries of the city are varied and growing rapidly. They include five lumber yards, two flour mills (daily capacity 3,000 bbls.), vitrified brick and tile factory, two ice plants, incubator factory, washing machine factory, broom factory, cigar factories, foundries, machine shops, tent and awning factory, granite and stone works, planing mill, gas and electric plants, ice cream factory, steam laundry, wholesale groceries, etc. El Reno has 15 churches and 7 public schools, the new High School costing \$100,000; school enrolment of 1,600 and a teaching force of 45. The Sacred Heart Institute (Catholic) has an enrolment of 200, with graded, high school and music courses. There is also a business college, Carnegie Library and two hospitals. The Masons and Elks possess fine buildings and the El Reno theatre has a seating capacity of 1,400. The new office building of the Rock Island system cost \$150,000, and the city hall cost \$50,000. New Federal building cost \$120,000. The El Reno Country Club has a fine clubhouse and maintains one of the finest golf courses in the State. The Grand Lodge Masons maintain the State Masonic Home at this point, owning 640 acres which the United States government sold to that body recently; fine buildings already built and plans for one of the finest homes in the country are being laid. Old Fort Reno, nearby, has been converted into a remount station, where horses are gentled and trained for cavalry purposes for use in United States Army. In 1911 El Reno adopted the commission form of government, the executives being commissioner of public affairs—ex-officio mayor, commissioner of finance and commissioner of highways. The city owns its own water plant and extensions, with a capacity of 1,500,000 gallons daily, has 10 miles of paved streets and 15 miles of sewers. The taxable valuation is about \$7,000,000. The city has four banks, with a capital and surplus of \$175,000 and average deposits of \$1,500,000. It was first settled in 1890, made a borough the same year and a city of the first class in 1892. The population has increased very fast, being now over 10,000.

**EL SABIO, Alfonso X**, king of Leon and Castilla: b. 23 Nov. 1221; d. 21 April 1284. He was the son of Ferdinand III and Beatriz, daughter of Philip of Suabia and sister of Frederick II of Germany. Most carefully educated, he succeeded his father to the throne in 1252, bringing with him to his administrative tasks the

reputation of successes gained in several campaigns against the Mohammedans. His reign was cursed with insurrections led by powerful nobles, financial troubles and warlike movements on the part of the Mohammedans. On the death of William of Holland, emperor of Germany, Alfonso laid claim to the throne as the direct heir. He was opposed in this by most of the nobles of Germany and by the Pope. Nevertheless he maintained the struggle against superior powers for 13 years. In this struggle, he was often opposed by some of the most powerful ruling dukes of Spain. Notwithstanding all his reverses he fought stubbornly on, claiming for himself the ancient title of king of the Romans; and signing his official documents with the great seal belonging to that dignity. He made ready several times to invade Italy and Germany, but trouble at home withheld his arm when he was ready to strike. Finally the united efforts of his powerful enemies and the threat of the Pope to excommunicate him, combined with ever-increasing trouble at home, forced Alfonso, in 1275, to renounce his claims upon the ancient throne of the Romans. The opposition to the successive popes to the claims of Alfonso on the crown of Germany was due to the fact that he was the representative of the Suabian princes, long the bitter and uncompromising enemies of the papacy. Alfonso was the more inclined to make peace with his enemies abroad in 1275 because of the increased trouble which the Mohammedans were giving him at home. In Granada, Murcia, Andalucía, Algarve and all the populous centres from Murcia to Jerez the Moors rose up against the Christian king in an effort to drive Christianity out of Spain. Alfonso besieged and captured Jerez, Medina-Sidonia, Rota, Santucar, Lebrija and Arcos; and the Castile fleet, under the command of Don Juan García de Villamayor, took Cádiz. In 1264 Jaime of Aragón came to the aid of Alfonso. The former captured the province of Murcia while Alfonso carried on the war against Andalucía. These constant wars and the struggle against Italy and Germany forced the king to increase the taxes. This estranged many of the nobles upon whom fell this burden of increased taxation; and Alfonso was forced to make concessions to his underlords which gave them great facilities for the oppression of their tenants. Thus the king ultimately lost the goodwill of nobles and peasants alike. The former, deserting the Castilian king, joined hands with the Moorish sovereigns of Granada, Mahomed I and Mahomed II. The treaty of peace with the Pope and with Germany in 1275, however, strengthened Alfonso, and enabled him to make temporary terms with his insurgent nobles. Alfonso departed for Rome (1275) for an interview with the Pope, leaving the cares of his kingdom in charge of his eldest son, Prince Fernando de la Cerda. The latter sent an army under Nuño González de Lara into Córdoba. There the invading forces met with considerable success at first; but in a short while they were surrounded by a greatly superior Moorish force and defeated with heavy loss, among the dead being Nuño and over 400 of his bodyguard. The survivors took refuge in the town of Ecipa (May 1275). The regent died in July while on his way to the relief of the besieged Castilian

forces; and Sancho, second son of King Alfonso, a boy of 18, at once took charge of the expeditionary force which he managed with considerable skill. Alfonso, on his return from Italy, made a two years' peace with the Moors, on the conclusion of which the latter again made an attempt to conquer the Christian possessions in Spain. Don Sancho led an army into Granada where he fell into an ambuscade and suffered defeat, losing over 3,000 of his finest knights. Sancho continued with the remainder of his forces on into the heart of Granada, burning villages and towns and laying waste the country he traversed. But the Castilians were forced to retreat to Córdoba (1281). The following year Alfonso and Sancho quarreled over the succession to the throne and the son declared himself in open insurrection against the father. Sancho stirred up the towns of the country against the king and even sought the aid of the enemies of Christian Spain. But the Pope threw his influence in favor of Alfonso and most of the nobles, obeying the spiritual head of the Church, returned to their allegiance (1282). Alfonso disinherited his son and carried the war on with the aid of Yacub, ruler of Morocco. The insurrection lost ground rapidly, but just as everything was turning in his favor Alfonso died.

Alfonso the Wise occupies a prominent place in Spanish history as a legislator. He gave uniformity to the laws of his united kingdom, which were, on his coming to the throne, a confused mass of privileges and local observances, often at variance with one another, and frequently subversive of the order of the nation. Out of this confused mass of privileges and local laws he succeeded in creating a certain uniformity of legal observances whose influences were felt in Spain for centuries. He wrote the 'Septenario,' a work wonderful in its day and for the political conditions under which it appeared. This is a sort of political, moral and religious compilation which has served as the basis of numerous legal works which have developed the law of Spain. In this and other works of a like nature Alfonso shows an intuition of the spirit of law and a knowledge far ahead of his time. His 'Libro del Espéculo ó Espejo de todos los derechos' and 'Fuero Real' are works scarcely less notable than the 'Septenario.' They were the result of much thought and investigation. They both appeared together in 1255. The 'Libro del Espéculo' (Book of Laws) is a summing up of what appeared to Alfonso to be the most just statutes or custom laws of Leon and Castile, and they were compiled to be used in adjudging all cases brought before the king's court. The 'Fuero Real' (royal law, in contradistinction to municipal or community law) was a compilation of the laws and usages of the different communities of the kingdom, for use in the courts of the common people. Alfonso's intention in writing the 'Fuero Real' was to do away with the anarchy in local law which reigned everywhere throughout his dominions. As these laws prohibited countless abuses, their enforcement was bitterly opposed by the nobles and others in high office throughout the land. These works were followed by the 'Libro de los Leyes' (Book of Laws), also known as 'Las Siete Partidas' (Seven Parts) on account of its being divided into seven sec-

tions. It was the first great legal code of the Middle Ages. In this and his other works Alfonso shows exact knowledge and appreciation of the laws of the Romans, of the Justinian Code and of Spanish and foreign laws of his day and of the ages preceding him. In addition to these virtues, his works have been long considered as literary models in their field. They form a wonderfully interesting and useful exposition of the laws, morality and religious uses, observances and practices of the age in which they were written. The ability, industry, powers of assimilation and excellent judgment of the king are evidently shown in his writings which called for a mastery of three great fields of knowledge, common and royal law, canonical law and theology. In his work he had, no doubt, helpers and investigators, but he was himself the heart and soul of it all; and his was the master mind that brought order out of confusion and conceived plans whose broadness were a century ahead of their time. Alfonso was a great lover, not only of everything relating to law, but also of literature and science; and the extent of his knowledge is often surprising. He was a poet of no mean talent and he encouraged the troubadours of Provence and Catalonia. His knowledge of history was very broad and exact; and he had mastered the extensive mathematical knowledge of the Arabs, so that, even among the Moors, he had acquired a reputation as a mathematician. It is not strange, therefore, that he should have done much, by his example and his influence, to advance the general culture of his kingdom. Of the many debts that Spain owes to him, one of the greatest and of most far-reaching consequence, is the fact that, for years, he labored to make the tongue of Castile the language of the whole country. This tended to create the national unity for which he strove. Though he was disappointed in the result of his work in his lifetime, it bore abundant fruit in after days. He encouraged education and established schools of higher learning in Toledo, Córdoba and Sevilla, and he welcomed to his court the troubadours. He ordered the Bible and various other works translated into Spanish, among them books on scientific subjects written in Hebrew or Arabic. In addition to his 'Cantigas' numerous other works of a non-legal nature have been attributed to him, in some cases apparently with considerable reason, among these being 'Estoria de Espanna ó Crónica General' and 'Grande y General Estoria.' Consult Ticknor, 'History of Spanish Literature' (New York, 1854); any good history of Spain, or history of Spanish literature.

JOHN HUBERT CORNYN,

*Editorial Staff of The Americana.*

**EL SOMBRERO DE TRES PICOS**  
(The Cocked Hat). The journalist and novelist Pedro Antonio de Alarcón (1833-91) met with little acclaim for his more ambitious literary performances; in fact, he attained to no measure of success in his novels. With his short stories, however, he gained a well-deserved repute, and with two of them, the 'Sombrero de Tres Picos' and the 'Capitán Veneno,' which are really long enough to be termed novelettes, he won his permanent place in the annals of Spanish prose fiction. The 'Capitán Veneno' is entirely of his own de-

vising; the 'Sombrero de Tres Picos,' on the other hand, is the result of his refashioning an old narrative previously decked out in prose form by the Italian Boccaccio in his 'Decameron' (VIII, 8) and refurbished for French readers in the 'Cent nouvelles nouvelles.' Alarcón may have known these versions of the story, but he certainly derived his direct inspiration from the treatment accorded to it in two popular Spanish ballads which may be seen in the 'Romancero general,' and he drew upon his own powers of invention for factors and embellishments which are not present in these verse sources. The subject of the 'Sombrero de Tres Picos' is one which required delicate handling if the unduly scabrous was to be avoided in the telling. It would have been easy for any author to run aground on the shoals of what the literary critics now call naturalism in the treatment of a theme which, like this, involves attempted adultery as a necessary element. But there is no indulgence shown here for the vicious, and whatsoever elements of the unbecoming are inherent in the popular tradition and are perforce adopted in Alarcón's story are sufficiently countered by the firm way in which the Corregidora, safeguarding her own honor and rescuing that of the peasant woman *señá* Frasquita, dispenses poetic justice to her own recreant husband. Humor of incident is rife in the work. It may be noted that Alarcón's redaction of the old legend has been utilized for operatic purposes in both French and German.

J. D. M. FORD.

**ELÆAGNUS**, *ël-ë-ag'nüs*, a genus of shrubs or small trees of the family *Elæagnaceæ*. The species, of which there are about 40, are natives of the northern temperate zone, and are characterized by deciduous or persistent entire leaves covered with silvery or brownish scales, solitary or clustered apetalous axillary flowers and one-seeded drupaceous fruits. They are valued in ornamental gardening for their foliage, usually decorative fruits, and mostly fragrant flowers. The deciduous members are hardy in the north; the evergreen ones, which mostly come from Japan and China, only in the south. They are easily propagated by means of seeds, cuttings and layers, and succeed upon almost any well-drained soil in a sunny situation. The best known species probably are: (1) *E. angustifolia*, the oleaster or white olive; which attains a height of about 20 feet. It has been introduced from southeastern Europe or adjacent Asia, and has proved hardy in the bleak and cold prairie States. It is one of the most ornamental species. (2) *E. argentea*, the silver-berry, a native of the colder parts of Canada and the northern border of the United States: It seldom attains a height exceeding 15 feet, and is perhaps the most popular native species. (3) *E. multiflora*, the gumi, a species introduced from eastern Asia. It is gaining in favor. It attains a height of about six feet and, like the preceding, bears edible, slightly acid fruit of pleasant flavor. This last species became of horticultural importance during the last 25 years of the 19th century because it produces good crops of fruit in climates too rigorous for most of the other fruit-bearing shrubs and trees.

**ELÆIS**, *ë-lë'is*, the name given to a genus of palms. The seven species are dioecious or monoecious, the flowers, especially the males, in dense masses, packed very closely together; the fruit is partly three-sided, but somewhat irregular. *E. guineensis*, the maba or oil-palm of the West African coast, has heads of large fruits. The outer or fleshy part of the fruit is boiled in water, when the oil rises to the surface and may be skimmed off. In its native country it is used for butter. It constitutes one of the chief commercial products of western Africa. *E. melanococca* also furnishes oil. Both species yield by manufacture palm-wine.

**ELÆOCARPUS**, *ë-lë-ë-kär'püs*, a genus of plants of the *Elæocarpaceæ*. The species are shrubs and trees and are found chiefly in New Zealand, Australia and southeastern Asia. From the seed-stones of *E. ganitrus* the natives of Australia make necklaces. The New Zealanders find a rich black dye in *E. lunou*, and in India several species furnish one of the ingredients of curry-powder.

**ELÆODENDRON**, *ë-lë-ë-dën'drön*, a genus of the staff-tree family (*Celastraceæ*). The plants of the genus are generally trees, natives of southern Asia, western and southern Africa and South America. The drupes of *E. kubu* are eaten at the Cape of Good Hope while the bark of *E. roxburghii*, rubbed with water, is used by the Hindus as an external application to swellings of all kinds. *E. glaucum*, a native of Ceylon, is sometimes called the Ceylon tea-tree. Saffronwood is the product of *E. croceum*, and an oil in common use in Africa is made from *E. argan*.

**ELAGABALUS**, *ë-la-gäb'a-lüs*, or **HELIOGABALUS**, *hë"li-ë-gäb'a-lüs*, Roman emperor: b. Emesa 204 A.D.; d. 222. His real name was Varius Avitus Bassianus, but when a youth he was appointed high priest of the Syro-Phœnician sun-god Elagabol and assumed the name of that deity. Soon after the death of his cousin Caracalla, Elagabalus was proclaimed emperor by the soldiers in opposition to the legitimate sovereign, Macrinus. The rivals met in battle at Antioch 218 A.D., Macrinus was defeated and Elagabalus assumed the purple. His reign of three years and nine months was infamous for the debaucheries of every kind in which he indulged. He instituted ceremonies in honor of the god Elagabol and it is believed made human sacrifices to him. He was murdered in an insurrection of the Prætorians and was succeeded by his cousin and adopted son, Alexander Severus, whose assassination he had twice attempted. Consult Butler, O. F., 'Studies in the Life of Heliogabalus' (New York 1908).

**ELAINE**, *ë-lä'in*, or **ELAIN**, the oily principle of fat, obtained by submitting fat to the action of boiling alcohol, allowing the stearin to crystallize and then evaporating the alcoholic solution; or by the simple process of pressing any oily or fatty substance between folds of blotting paper, the oily matter or Elaine is absorbed, while the stearin remains. The paper being then soaked in water and pressed, yields up the Elaine. It possesses much the appearance and properties of vegetable oil, and olein (q.v.) is liquid at the temperature of 60° F. and has an odor derived from the solid fats from which it has been extracted.

**ELAM**, the ancient name of a country or region in Asia, east of the Lower Tigris. The cuneiform inscriptions record that a king of Elam conquered Babylonia and Assyria about 2300 B.C. The later ancient writers call this country Susiana, the name being derived from its capital, Susa or Shushan, one of the most ancient cities of the East. It is now known as Khoozistan. Both the country itself, which seems to have been of considerable importance at an early period, and its capital, Shushan, are mentioned in the Bible. Consult Sayce, 'Inscriptions of Mal Amir'; Loftus, 'Travels and Researches in Chaldæa and Susiana'; Billerbach, 'Susa'; Dieulafoy, 'L'Acropole de Suse'; Meyer, Ed., 'Geschichte des Altertums (1913)'; Scheil, De Morgan, and others in 'Mémoires de la délégation en Perse' (1900-13).

**ELAND**, e'land, the largest antelope (*Oreas canna*) found in Africa. It is as big as a fully grown horse, weighs 1,000 pounds or more and stands fully six feet high. The early settlers in South Africa called it "elk." The eland has a short, smooth coat of rich fawn color; strong, straight horns about 20 inches long, and a broad fringed dewlap falling about to the knees. The hide makes excellent harness leather and the flesh is decisively palatable. The elands move so slowly and are such gentle creatures as to be easily caught, and hence have been nearly exterminated in their native haunts. At present very few are found. In the equatorial region of western Africa is found the still larger species (*Oreas derbianus*).

**ELAPHURE**, name for David's deer (*Cervus davidianus*), whose habitat is Northern China and Manchuria. It is commonly kept in parks by wealthy Chinese and even in Europe. Little is known of its habits in the wild state. It has long shaggy hair and has no brow tine to its antlers.

**ELAPINÆ**, ě-lăp'ĩ-nē, a subfamily of *Colubridæ*, including venomous snakes having a short, rounded head covered with plates. They are more nearly related to the harmless colubrines than to the vipers, but have a poison-apparatus of the proteroglyph type. The group is a large one and is found in most parts of the world, but is most numerous in the tropics. Nearly all the snakes of Australia are elapine, the whole race of cobras (q.v.), and others. The genus *Elaps* is entirely American and is represented by a single species in the United States, the coral or harlequin snake of Florida. See CORAL SNAKE.

**ELASMOBRANCHII**, ě-lăs-mō-brăng'kĩ-ĩ, a sub-class of fishes, containing the sharks and rays. The skull is cartilaginous with only superficial calcifications and no true dermal bones; the gills fixed and shaped like pouches; the upper jaw is the pterygo-palatine bar, and the lower jaw Meckel's cartilage, attached to the skull by a large hyo-mandibular element; the exo-skeleton consists of tooth-like granular tubercles or spines; and the trunk endoskeleton is cartilaginous. The ventral fins are far back and bear claspers in the males; the heart has but one auricle and one ventricle; and the intestine is provided with a spiral valve. The group is nearly coextensive with Cuvier's *Chon-*

*dropterygia* or cartilaginous fishes and the Placoidæ of Agassiz, and has received various other names such as *Selachii* and *Plagiostomi*. Cope distinguishes as orders the *Selachii*, which includes all living as well as many extinct forms; and the *Ichthyotomi*, which are exclusively carboniferous and have simple claspers and extensive cranial calcifications. See DOG-FISH; RAY; SAWFISH; SHARKS; SKATE, etc.

**ELASMOSAURIANS**, ě-lăs-mō-să'riănz, gigantic marine fossil reptiles of the order *Sauropterygia*, found in cretaceous beds. As a living animal it was contemporaneous with *Plesiosaurus*, of the same order, which abounded in the eastern hemisphere, and as a fossil has been found in Europe and New Zealand. *Elasmosaurus* had a lizard-like, elongated body, sometimes 45 feet long, flattened limbs which served as oars, and a long, paddle-shaped tail which assisted its motion through the water. The head was proportionately small and with the neck performed twisting motions much like the corresponding parts of the swan. The contents discovered in the body indicate that this sea-saurian lived on other rapacious fish, which it was able to seize with its crocodile-teeth. The fossil has been raised from cretaceous beds in New Jersey and in Kansas.

**ELASMOTHERIUM**, ě-lăs-mō-thē'ri-ŭm, an extinct rhinoceros which inhabited Siberia, Russia and Germany during the Pleistocene Epoch. It exceeded the Indian rhinoceros in size and bore an enormous horn on the frontal bone of the skull, but no nose-horn. The teeth are very long-crowned, with the enamel ridges strongly crenulated, indicating grazing habits. Some of the native Siberian legends are supposed to refer to this animal; it was a contemporary of early man in that region. See RHINOCEROS.

**ELASTIC LIMIT**. See STRENGTH OF MATERIALS.

**ELASTIC TISSUE**, fibrous tissue in most cases mixed with the fibres of areolar tissue. It occurs in the ligaments of the vertebrae, that of the jaw, etc., also in connection with arteries, veins and lymphatics. It is found in the animal structure whenever an extensible and highly elastic material is required.

**ELASTICITY**. Every solid, no matter how rigid we may think it to be, will have its dimensions changed upon the application of force. If the resulting distortion does not exceed a certain amount it will disappear when the force is removed. Bodies which recover from the distorting effect of force and resume their original configurations are said to be *elastic*. The relation between force and the deformation it produces is studied under the title *elasticity*; the harmful effects of distortion and the proportioning of materials safely to resist given forces belong to the *strength of materials* (q.v.). The behavior of gases comes under *thermodynamics*, of liquids under *hydrodynamics*. In the mechanics of rigid bodies forces are represented by arrows placed at points; actually, they are distributed over surfaces. We are concerned here with the area of action as well as with the magnitude of the

force, and shall therefore use the word *stress* to denote *force per unit area*. Stress, contrary to this usage, is generally regarded as synonymous with force, and what we here call stress is commonly called "intensity of stress" or "unit stress." Stress as defined in this article is not force; its dimensions are  $FL^{-2}$  or  $ML^{-1}T^{-2}$  and the unit is the pound or ton per square inch and the dyne and kilogram per square centimeter. A force oblique to a surface can be resolved into normal and tangential components. The resulting normal stress is accompanied by change of length. The change of length per unit length is called *linear strain*; there are likewise areal and volumetric strains. Strain is a pure number without dimensions. Tangential stress or *shear stress* produces angular distortion due to the sliding of one layer of material with respect to the adjacent layers. For instance, if the two covers of a book are shifted parallel to each other there will be relative sliding of the leaves. Any straight line drawn on the top or bottom end of the book will change its inclination; the change of a right angle is called *shear strain*. It is the province of the theory of elasticity to investigate mathematically the consequences which result from an experimentally found relation between stress and strain. The first experiments—on the rupture of beams—were made by Galileo, 'Discorsi e Dimostrazioni matematiche' (1638). His results were of no value because he supposed the fibres of a beam to be inextensible, yet his work was the impulse to subsequent inquiries. It was not until 1678 that any relation between stress and strain was published. In that year Hooke in his 'De potentia restitutiva,' announced the law known by his name in the form of an anagram *ceiinnossttluu* containing the letters of *Ut tensio sic vis*, i.e., *the force varies directly as the extension*. He claimed to have discovered it in 1660. Until the end of the 18th century only special problems on beams, columns, and plates were attacked; this period was almost barren of experimental work. The foundation of the mathematical theory was laid by Navier, 'Mémoire sur les lois des corps solides élastiques,' *Mémoires de l'Institut*, Vol. VII, which was read to the Académie des Sciences in 1821. Progress was rapid after this in the hands of such masters as Cauchy, Clapyron, Green, Lamé and Poisson, and culminated in the life-long labors of Barré de Saint-Venant (1797-1886). For the detailed history of the subject through the time of Saint-Venant consult Todhunter and Pearson, 'History of the Theory of Elasticity and of the Strength of Materials' (Cambridge 1886); subsequent investigations are noted in the introduction to Love, 'The Mathematical Theory of Elasticity' (2d ed., Cambridge 1906).

*Strain.* Before taking up the relations between stress and strain, we shall study the small displacements suffered by an infinitesimal element  $dx dy dz$  within a medium in any state of stress. Fig. 1 shows the projections of two concurrent edges on the  $xy$  plane before and after displacement; the  $yz$  and  $xz$  diagrams are omitted for brevity. Let  $(x, y, z)$ , the corner nearest the origin, be displaced  $u, v, w$ , where  $u, v, w$  are small compared with  $x, y, z$ . Then, to terms of the first order, the ends of

$dx$  and  $dy$  receive the axial displacements shown. For if a variable increases infinitesimally, the function will increase differentially; thus if the left end of  $dx$ , distant  $x$  from the origin, moves  $u$  parallel to  $x$ , a point

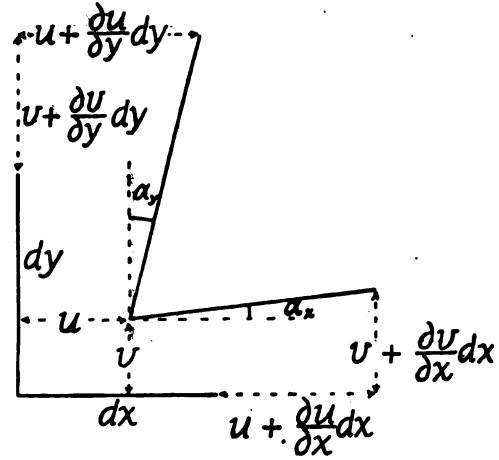

FIG. 1.

infinitesimally further from the origin will move infinitesimally more, i.e.,  $u + \frac{\partial u}{\partial x} dx$ , the derivative being partial to indicate that the increment was due only to a change of  $x$ . The  $x$ -projection of the elongated length of  $dx$  is  $dx + \frac{\partial u}{\partial x} dx$ , which, since  $x$  is infinitesimal, is itself the new length of  $dx$ . Hence the stretch of  $dx$  is  $\frac{\partial u}{\partial x} dx$  and if the linear strain at  $x, y, z$  is denoted by  $e_{xx}$

$$e_{xx} = \frac{\partial u}{\partial x}, \quad e_{yy} = \frac{\partial v}{\partial y}, \quad e_{zz} = \frac{\partial w}{\partial z} \quad (1)$$

the other two components being derived by cyclic permutations of the letters. By definition the shear strains are the decrements of the right angles formed by the concurrent edges at  $(x, y, z)$ . If they are denoted by  $e_{xy}, e_{yz}, e_{zx}$  in the co-ordinate planes it is evident from Fig. 1 that  $e_{xy} = \alpha_x + \alpha_y$ . Since  $\alpha_x$  is infinitesimal by hypothesis, it equals its tangent  $\frac{\partial v}{\partial x}$ ; likewise  $\alpha_y = \frac{\partial u}{\partial y}$ .

$$\begin{aligned} \therefore e_{xy} &= \frac{\partial v}{\partial x} + \frac{\partial u}{\partial y}, \\ e_{yz} &= \frac{\partial w}{\partial y} + \frac{\partial v}{\partial z}, \\ e_{zx} &= \frac{\partial u}{\partial z} + \frac{\partial w}{\partial x} \dots (2) \end{aligned}$$

The six quantities  $e_{xx}, \dots, e_{xy}, \dots$  are the components or constituents of strain at the point  $(x, y, z)$ . The shear strain suffered by an element rotates it as a whole, the amount being measured by the rotation of its diagonal.

Consider the effect of a partial strain  $\frac{\partial u}{\partial y}$  all other displacements being zero. There will be

no loss in generality if we take a square instead of a rectangle in Fig. 2, because the strain components are independent of the mag-

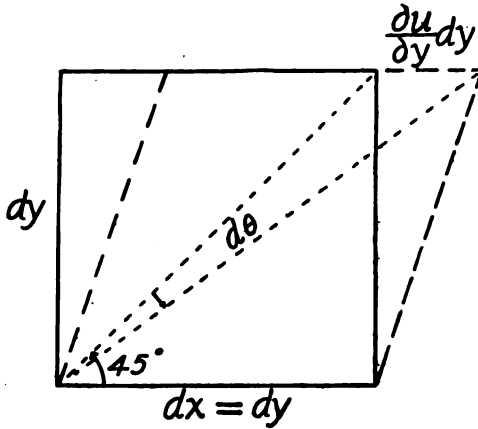

FIG. 2.

nitudes of  $dx, dy, dz$ . From Fig. 2

$$dy = \left( dx + \frac{\partial u}{\partial y} dy \right) \tan(45 - d\theta)$$

Now  $\frac{\partial u}{\partial y} dy$  is small compared with  $dx$  because  $u$  is by assumption small compared with  $x$ ; then as  $dy = dx$ , the equation reduces to

$$d\theta = \frac{1}{2} \frac{\partial u}{\partial y}$$

In the same way  $\frac{1}{2} \frac{\partial v}{\partial x}$  is the counterclockwise

rotation of the diagonal due to shearing of the right side of the element. The resultant positive ( $X$  toward  $Y$ ) rotation about the  $Z$ -axis is

$$\omega_z = \frac{1}{2} \left( \frac{\partial v}{\partial x} - \frac{\partial u}{\partial y} \right);$$

likewise  $\omega_x = \frac{1}{2} \left( \frac{\partial w}{\partial y} - \frac{\partial v}{\partial z} \right), \dots \dots \dots (3)$

$$\omega_y = \frac{1}{2} \left( \frac{\partial u}{\partial z} - \frac{\partial w}{\partial x} \right),$$

$\omega_x$  and  $\omega_y$  being obtained by cyclic permutation. These are the component rotations; when they vanish the strain is *irrotational* or *pure*. There are always at least three orthogonal lines whose directions remain unaltered by strain; they are called the *principal axes* and the planes normal to them the *principal planes*. If  $u, v, w$  are eliminated from equations (1) and (2) there will be three equations of the form

$$\frac{\partial^2 e_{xx}}{\partial y^2} + \frac{\partial^2 e_{yy}}{\partial x \partial y} = \frac{\partial^2 e_{xy}}{\partial x \partial y} \dots \dots \dots (4)$$

and three of the form

$$2 \frac{\partial^2 e_{xx}}{\partial y \partial z} = \frac{\partial}{\partial x} \left( \frac{\partial e_{xy}}{\partial z} - \frac{\partial e_y}{\partial x} + \frac{\partial e_{xz}}{\partial y} \right), \dots \dots \dots (4)$$

the others being written by permuting  $x, y, z$ . These are the equations of compatibility and must be satisfied by every solution of a problem in elasticity. Many of the formulas derived in the strength of materials are not compatible with theory although they may be reasonably in accord with experiment.

*Stress.*—A stress will be denoted by a capital letter to indicate its direction, with a subscript to show the normal to plane on which it acts. Thus  $X_x$  is parallel to  $X$  on a plane ( $YZ$ ) normal to  $X$  and is a normal stress;  $Y_x$  is a shear parallel to  $Y$  on the  $XY$  plane. Fig. 3 shows an element under coplanar stress,

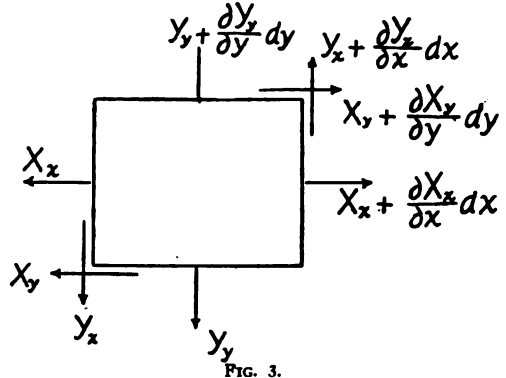

FIG. 3.

all stresses parallel to  $Z$  being zero. It will be seen from the theorem about to be derived that there can be no shear on planes parallel to the paper if there is none normal to the paper. Taking moments of the forces about the upper right-hand corner (edge) we find, after rejecting terms which vanish in the limit,

$$X_y = Y_x;$$

it is to be observed that the weight and the moment of inertia of the element are vanishingly small. The diagram shows that the shears on two orthogonal faces both point away from, or both toward the edge, hence the

**Theorem:** Shear stress on any plane is accompanied by equal shear stress on a perpendicular plane, both acting away from or toward the edge of intersection and both being normal to it.

This is due to Cauchy. For the other shears

$$Y_z = Z_y, Z_x = X_z$$

The translations of the element in Fig. 1 are  $u, v, w$ , whence the axial accelerations are  $\frac{\partial^2 u}{\partial t^2}, \frac{\partial^2 v}{\partial t^2}, \frac{\partial^2 w}{\partial t^2}$ ; the derivatives are partial because they must denote only time-changes and not space-changes. From the general free body of which Fig. 3 is a special case we get by resolving the forces axially

$$\begin{aligned} \frac{\partial X_x}{\partial x} + \frac{\partial X_y}{\partial y} + \frac{\partial X_z}{\partial z} + \partial X &= \partial \frac{\partial u}{\partial t^2} \\ \frac{\partial Y_x}{\partial x} + \frac{\partial Y_y}{\partial y} + \frac{\partial Y_z}{\partial z} + \partial Y &= \partial \frac{\partial v}{\partial t^2} \dots \dots \dots (5) \\ \frac{\partial Z_x}{\partial x} + \frac{\partial Z_y}{\partial y} + \frac{\partial Z_z}{\partial z} + \partial Z &= \partial \frac{\partial w}{\partial t^2} \end{aligned}$$

where  $\partial$  is the density and  $X, Y, Z$  are the components of the applied forces (e.g. weight) *per unit mass*.

At the surface the internal stresses  $X_x, \dots, X_y, \dots$  must be in equilibrium with the external or applied stresses.

*Relations between stress and strain.* A material is elastically *isotropic* when it resists stress with equal intensity in all directions. Crystals, fibrous materials, and metals which



have been heavily rolled or otherwise worked are unequally strong in different directions; they are *eolotropic*. It has been found by experiment that for many bodies

$$\text{stress} = C \times \text{strain};$$

$C$  is called the *modulus of elasticity*. It is constant for a given isotropic material but depends upon the kind of stress; an eolotropic body has several moduli for each type of stress. The law takes the following special forms.

(1) For normal stress  $p$  and linear strain  $e$  in the direction of  $p$

$$p = Ee;$$

$E$  is called Young's modulus after Thomas Young who introduced it in 1807. For granular materials like cast iron and stone a more accurate form is  $p = Ee^n$  where  $n$  lies between 1 and 1.1; we shall assume that  $n = 1$ . (See STRENGTH OF MATERIALS).

The longitudinal strain  $e$  is always accompanied by a strain  $e'$  of the transverse dimensions; for a given material

$$e' = \sigma e$$

where  $\sigma$  is constant for isotropy. Thus if a rod receives a longitudinal strain  $e$  the strain of any straight line in a cross-section is  $\sigma e$ ;  $\sigma e$  is not an areal strain. In engineering  $1/m$  is used for  $\sigma$ .  $\sigma$  is called *Poisson's ratio* after Poisson, who in 1828 calculated it to be  $1/4$  for all materials; experiment has not verified his prediction.

(2) For shear stress  $q$  and strain  $\phi$

$$q = \mu\phi;$$

$\mu$  is the modulus of shear or of rigidity. Young was the first to point out that resistance to "detrusion," as he called shear, was different from resistance to stretching. But he did not introduce the shear modulus; this was done by Navier in 1833. The symbol  $\mu$  was first used by Lamé in 1852; in books on the strength of materials  $N$  and  $G$  are used for  $\mu$ .

(3) A constant normal stress  $p$  over the entire surface of a body produces a volumetric strain  $\Delta$ , called the *dilatation*, where

$$p = k\Delta,$$

$k$  being the bulk modulus or modulus of compression.

For isotropic bodies there are thus four constants of elasticity:  $E, \mu, \sigma, k$ . It will be shown later that only two of them are independent. Stokes in 1845 ('Mathematical and Physical Papers,' Vol. I, p. 75) pointed out that  $\mu$  and  $k$  are of basic importance in theoretical work; in engineering  $E$  and  $\mu$  are more convenient.

For eolotropic substances we may still assume the stress to be a linear function of the strain, in which case the generalized forms of Hooke's law are

$$X_x = C_{11}e_{xx} + C_{12}e_{yy} + C_{13}e_{zz} + C_{14}e_{xy} + C_{15}e_{yz} + C_{16}e_{zx}$$

$$Y_y = C_{21}e_{xx} + C_{22}e_{yy} + C_{23}e_{zz} + C_{24}e_{xy} + C_{25}e_{yz} + C_{26}e_{zx}$$

and so on for  $Z_z, X_y, Y_z, Z_x$ , the 36 coefficients,  $C_{11}$  to  $C_{33}$ , being the elastic constants. Green in 1837 proved that for conservative systems  $C_{mn} = C_{nm}$  whereby the constants reduce to 21 for eolotropy. For isotropy they reduce to 2. To express the stresses in terms of strains for isotropy consider the effect of a single tension  $X_x$ . By Hooke's law it produces a strain  $X_x/E$  in its own direction, and

according to Poisson's ratio, a lateral compressive strain  $\sigma X_x/E$ . Hence if a parallelepiped is acted on by tensions  $X_x, Y_y$ , and  $Z_z$ , the resultant axial strains will be given by

$$Ee_{xx} = X_x - \sigma(Y_y + Z_z)$$

$$Ee_{yy} = Y_y - \sigma(Z_z + X_x) \dots (6)$$

$$Ee_{zz} = Z_z - \sigma(X_x + Y_y);$$

$e_{xx}, e_{yy}, e_{zz}$  are called the equivalent simple strains, and when multiplied by  $E$ , the equivalent simple stresses. By addition

$$E(e_{xx} + e_{yy} + e_{zz}) = (X_x + Y_y + Z_z)(1 - 2\sigma);$$

the first parenthesis is the volumetric strain because the change of volume is

$$(1 + e_{xx}) dx (1 + e_{yy}) dy (1 + e_{zz}) dz - dx dy dz = (e_{xx} + e_{yy} + e_{zz}) dx dy dz$$

if the strains are so small that terms above the first order are negligible. The volumetric strain or *dilatation*  $\Delta$  is then

$$\Delta = e_{xx} + e_{yy} + e_{zz}$$

Now it is obvious from Fig. 2 that the infinitesimal shear  $\frac{\partial u}{\partial y}$  does not change the area of

the face  $dx dy$ ; if one does not, none will, so that shear does not change areas. In the same way it follows that infinitesimal shear will not alter volumes; this is why the dilatation contains only linear strains.

If the stresses in the equation following (6) are all equal to  $X_x$

$$3(1 - 2\sigma) X_x = E\Delta$$

whence, as  $p = k\Delta$

$$k = \frac{E}{3(1 - 2\sigma)}$$

If  $\sigma > 1/2$ ,  $k$  is negative whence volumes would be increased by compression and decreased by tension; as this does not occur  $\sigma$  cannot exceed  $1/2$ . Furthermore a negative  $\sigma$  would mean lateral expansion under tension; this is not true of isotropic materials. Therefore  $\sigma$  is a positive fraction not larger than  $1/2$ ; experiment verifies this.

If the first equation of (6) is written

$$X_x = Ee_{xx} + \sigma(X_x + Y_y + Z_z) - \sigma X_x$$

and the parenthesis eliminated by means of the equation below (6), there results

$$X_x = \lambda\Delta + 2\mu e_{xx};$$

$$\text{similarly } Y_y = \lambda\Delta + 2\mu e_{yy} \dots (7)$$

$$Z_z = \lambda\Delta + 2\mu e_{zz}$$

where

$$\lambda = \frac{\sigma E}{(1 + \sigma)(1 - 2\sigma)}, \quad \mu = \frac{E}{2(1 + \sigma)}$$

It will be proved later that  $\mu$  is the modulus of shear as defined above; hence

$$X_y = \mu e_{xy}, \quad Y_z = \mu e_{yz}, \quad Z_x = \mu e_{zx}, \dots (8)$$

Navier, Poisson, and Cauchy, the founders of the theory of elasticity, derived their equations from a hypothesis of intermolecular actions the consequences of which demanded that  $\lambda = \mu$ ; then  $\sigma = 1/4$ , contrary to experiment. They belonged to what Pearson has called the *vari-constant*, as opposed to the *multi-constant*, school of elasticians. The weight of evidence is in favor of the necessity of two constants for specifying the elastic properties of isotropic materials. To interpret  $\mu$  in the equations just found, consider a cubical element under

tension  $p$  on one pair of faces and compression  $p$  on a perpendicular pair, as on the full-line square in Fig. 4. By taking as a free-body the shaded corner cut off by a 45-degree plane and resolving the forces (stress  $\times$  area) parallel and normal to the oblique surface, we find

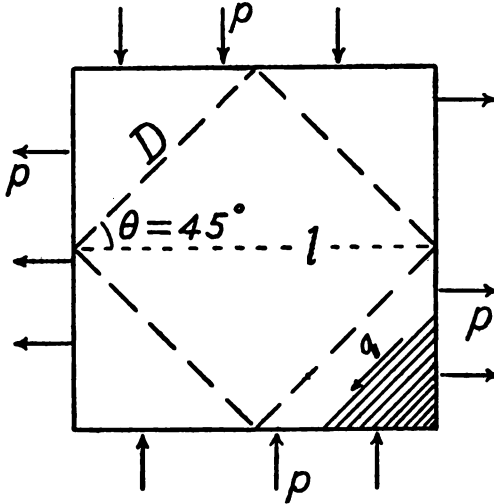

FIG. 4.

that a stress  $q=p$  on the oblique face is necessary and sufficient for equilibrium. That is, orthogonal, equal, unlike normal stresses produce pure shear of equal magnitude on any plane at 45 degrees. Take now the dash-line square as a free-body: it is in pure shear of magnitude  $q=p$ . Since the change of a right-angle is the shear strain  $\phi$ , the change of  $\theta(=45^\circ)$  is  $\phi/2$ . As the sides of the inner square are not altered in length,  $D$  is constant in

$$D = l \cos \theta \quad \text{whence} \quad \frac{dl}{l} = d\theta \tan \theta$$

But  $\theta = 45^\circ$  and  $d\theta = \frac{\phi}{2} \therefore \frac{dl}{l} = \frac{\phi}{2}$

By eq (6)  $\frac{dl}{l} = \frac{p}{E} + \frac{\sigma p}{E}$

and as  $\phi = \frac{q}{\mu} = \frac{p}{\mu}$   
 $\mu = \frac{E}{2(1 + \sigma)}$

For the purposes of integration it is convenient to eliminate the internal stresses from equations (5). Substituting equations (7) and (8) in (5), replacing the strains by their values in (1) and (2) and using the symbolic abbreviation—the Lapacian operator—

$$\nabla^2 = \frac{\partial^2}{\partial x^2} + \frac{\partial^2}{\partial y^2} + \frac{\partial^2}{\partial z^2}$$

we find

$$\begin{aligned} (\lambda + \mu) \frac{\partial \Delta}{\partial x} + \mu \nabla^2 u + \rho X &= \rho \frac{\partial^2 u}{\partial t^2} \\ (\lambda + \mu) \frac{\partial \Delta}{\partial y} + \mu \nabla^2 v + \rho Y &= \rho \frac{\partial^2 v}{\partial t^2} \dots (9) \\ (\lambda + \mu) \frac{\partial \Delta}{\partial z} + \mu \nabla^2 w + \rho Z &= \rho \frac{\partial^2 w}{\partial t^2} \end{aligned}$$

The internal motions specified by these equa-

tions are vibratory since they arise from small elastic displacements within the medium. The fact that they can be verified experimentally furnishes complete evidence of the correctness of Hooke's law, of our assumption that the displacements are small, and of the validity of the analysis.

*Applications.*—We shall now solve a few typical problems in order to show the use of the foregoing equations. Most problems unfortunately give rise to extremely difficult partial differential equations; the general methods of integration are fully discussed in the works by Love and Riemann-Weber cited at the end of this article.

(1) A cylinder of density  $\rho$  and length  $l$  is suspended from one end and hangs vertically.

Take the  $Y$ -axis vertical with the origin  $l$  below the upper end. Since  $Y_v$ , the tensile stress at any point, is due to the weight of the material below that point,  $Y_v = g\rho y$ ; the five remaining stresses are zero. There are no surface forces except at the upper end where the entire weight of the cylinder is uniformly distributed over the supporting surface; there the internal and external stresses balance. Hence

$$E e_{yy} = g\rho y, \quad e_{xx} = e_{zz} = \sigma e_{yy}, \quad e_{xy} = e_{yz} = e_{zx} = 0$$

Now

$$e_{yv} = \frac{\partial v}{\partial y} = \frac{g\rho y}{E}$$

$$\therefore v = \frac{g\rho y^2}{2E} + v_0 \dots (a)$$

where  $v_0$  is a function of  $x$  and  $z$  because the derivative is partial. Since there is no shear,  $v$  must satisfy

$$e_{xy} = \frac{\partial v}{\partial x} + \frac{\partial u}{\partial y} = 0, \quad e_{yz} = \frac{\partial v}{\partial y} + \frac{\partial w}{\partial z} = 0$$

whence  $\frac{\partial u}{\partial y} = -\frac{\partial v_0}{\partial x}, \quad \frac{\partial w}{\partial y} = -\frac{\partial v_0}{\partial z} \dots (b)$

By differentiation,

$$\frac{\partial^2 u}{\partial x \partial y} = -\frac{\partial^2 v_0}{\partial x^2}, \quad \frac{\partial^2 w}{\partial y \partial z} = -\frac{\partial^2 v_0}{\partial z^2}$$

But  $\frac{\partial u}{\partial x} = \frac{\partial v}{\partial z} = -\frac{\sigma g\rho y}{E}$

so that  $\frac{\partial^2 v_0}{\partial x^2} = \frac{\partial^2 v_0}{\partial z^2} = \frac{\sigma g\rho}{E} \dots (c)$

The value

$$v_0 = \frac{\sigma g\rho}{2E} (x^2 + z^2) + ax + cz + k \dots (d)$$

will satisfy equation (c); substitution in (a) gives

$$v = \frac{g\rho}{2E} (y^2 + \sigma x^2 + \sigma z^2) + ax + cz + k$$

At the upper end

$$v = 0 \text{ and } k = -\frac{g\rho l^2}{2E} \text{ when } x = 0, \quad y = l, \quad z = 0$$

The solution must be correct when the rod is rigid; in this case  $E = \infty$  and  $v = 0$  so that  $a = 0, c = 0$ .

Hence  $v = \frac{g\rho}{2E} (y^2 - l^2 + \sigma x^2 + \sigma z^2) \dots (e)$

The formula obtained in books on the strength

of materials is  $v = \frac{g\rho}{2E} (y^2 - r^2)$

which is therefore correct only along the axis; it is, however, approximately true at any point when the cylinder is very long compared with the radius.

Integrating (b), substituting (d), and supposing as above that  $E = \infty$ , we get

$$u = -\frac{\sigma g \rho x y}{E}, \quad w = -\frac{\sigma g \rho z y}{E}$$

if the upper end is free to contract.  
(2) A straight uniform rod is twisted by couples applied at the ends.

Saint-Venant was the first to solve the general problem in his great memoir on torsion, 1855, although Coulomb had previously, 1784, succeeded in finding the twisting moment offered by a circular cylinder. The following is a brief sketch of Saint-Venant's method.

Let the cylinder, of any cross-section, have its axis along Z. Since there is no shear on the mantle,  $X_y = 0$  and  $e_{xy} = 0$

$$\dots \frac{\partial v}{\partial x} = -\frac{\partial u}{\partial y} \dots (a)$$

As there are no external normal forces the normal strains vanish and

$$\frac{\partial u}{\partial x} = \frac{\partial v}{\partial y} = \frac{\partial w}{\partial z} = 0 \dots (b)$$

Equations (5) with  $X_x = Y_y = Z_z = X_y = 0$  become

$$\frac{\partial X_x}{\partial z} = \frac{\partial Z_y}{\partial z} = 0 \dots (c)$$

where  $X_x = \mu \left( \frac{\partial u}{\partial z} + \frac{\partial w}{\partial x} \right)$ ,  $Z_y = \mu \left( \frac{\partial w}{\partial y} + \frac{\partial v}{\partial z} \right)$  ... (d)

By equation (b)  $w$  does not contain  $z$  and by (c) and (d)  $u$  and  $v$  are linear functions of  $x$ . All the above equations will be satisfied only by

$$u = -\tau y z, \quad v = \tau x z, \quad w = \tau \phi \dots (e)$$

where  $\phi$  is a function of  $x, y$ . The values of  $u$  and  $v$  show that since  $u^2 + v^2 = \tau^2 (x^2 + y^2) z^2$  and  $u/v = -y/x$ , the displacement in the plane of the cross-section is (1) normal to the radius vector; (2) proportional to the radius vector; (3) proportional to the distance of the cross-section from the origin. Therefore radial straight lines remain straight and of constant length and the boundary of any section is not distorted in transverse planes. If  $\phi$  is not zero these lines will be warped in the direction of the cylinder axis;  $\phi$  is therefore the warping function.  $\tau$  is the angle of twist.

Equations (e) substituted in (d) give

$$X_x = \mu \tau \left( \frac{\partial \phi}{\partial x} - y \right), \quad Y_x = \mu \tau \left( \frac{\partial \phi}{\partial y} + x \right) \dots (f)$$

As there is no shear on the mantle the resultant of  $X_x$  and  $Y_x$  must be normal to the boundary of

any section, i.e.  $\frac{Y_x}{X_x} = \frac{\partial y}{\partial x}$

... from (f)

$$\left( \frac{\partial \phi}{\partial y} + x \right) dx = \left( \frac{\partial \phi}{\partial x} - y \right) dy \dots (g)$$

This is the differential equation of the boundary curve of any section.

The twisting moment equals the sum of the moments of the shear forces on any section, i.e.,

$$M = \int (x Y_x - y X_x) dx dy$$

$$= \mu \tau \int \left( x^2 + y^2 + x \frac{\partial \phi}{\partial y} - y \frac{\partial \phi}{\partial x} \right) dx dy \dots (h)$$

The angle of twist, found by differentiating (f)

and eliminating  $\frac{\partial^2 \phi}{\partial x \partial y}$ , is

$$\tau = \frac{\mu}{2} \left( \frac{\partial Y_x}{\partial x} - \frac{\partial X_x}{\partial y} \right) \dots (i)$$

The differential equation of a circle is  $x dx = -y dy$ ; equation (g) reduces to this when  $\phi$  is constant. As there is no lengthening of the cylinder there is no translation of a cross-section and  $\phi = 0$ . Now if  $\phi = ax + by$  (g) is the equation of a circle, but as the centre of the circle is at the axis of the cylinder it will be found that  $a$  and  $b$  must vanish. Hence for a circular section  $\phi = 0$  and cross-sections remain plane. In this case equation (h) gives the well-known engineers' formula.

Equation (g) will represent the ellipse

$$\frac{x^2}{a^2} + \frac{y^2}{b^2} = 1$$

provided

$$\phi = \frac{b^2 - a^2}{b^2 + a^2} x y$$

Since  $w = \tau \phi$ , the contour lines found by giving  $\phi$  a series of constant values are equilateral hyperbolas; in the first and third quadrants of the ellipse the displacements will be negative and in the other quadrants positive. Equation (h) gives

$$M = \mu \tau \pi \frac{a^2 b^2}{a^2 + b^2}$$

(3) Vibrations in an infinite elastic medium.

If there are no external forces,  $X = Y = Z = 0$ . Let all quantities in the XY plane be constant so that the same state exists throughout that plane; then the  $x$  and  $y$  derivatives in equations (9) are zero, whence

$$\Delta = \frac{\partial w}{\partial z}, \quad \frac{\partial \Delta}{\partial z} = \frac{\partial^2 w}{\partial z^2}$$

Likewise

$$\nabla^2 u = \frac{\partial^2 u}{\partial z^2}, \quad \nabla^2 v = \frac{\partial^2 v}{\partial z^2}, \quad \nabla^2 w = \frac{\partial^2 w}{\partial z^2}$$

The equations of motion thus reduce to

$$\left. \begin{aligned} \rho \frac{\partial^2 u}{\partial t^2} &= \mu \frac{\partial^2 u}{\partial z^2} \\ \rho \frac{\partial^2 v}{\partial t^2} &= \mu \frac{\partial^2 v}{\partial z^2} \end{aligned} \right\} \dots (a)$$

$$\rho \frac{\partial^2 w}{\partial t^2} = (\lambda + 2\mu) \frac{\partial^2 w}{\partial z^2} \dots (b)$$

Equations (a) are satisfied, as substitution will

verify, by any function of  $z \pm \sqrt{\frac{\mu}{\rho}} t$ . This

function must be periodic for otherwise the displacement would become infinite in course of time or would remain as a permanent set. Experiment contradicts both of these suppositions, hence the motion is vibratory. Equation (b) is satisfied by a similar function. If at a point  $z + dz$  at a time  $t + dt$  the displacement is in the same phase and of the same magnitude as it was at  $z$  at a time  $t$

$$z + dz + c(t + dt) = z + ct$$

where  $c^2 = \frac{\mu}{\rho}$  for (a) and  $c^2 = \frac{\lambda + 2\mu}{\rho}$  for (b);

$$\frac{dz}{dt} = \pm c,$$

which is the velocity of propagation of the disturbance: not the velocity of a material point but of a state of motion. Equation (b) defines the longitudinal, and (a) the transverse waves in an infinite elastic medium.

**Bibliography.**—Love, 'The Mathematical Theory of Elasticity' (2d ed., Cambridge 1906); Todhunter and Pearson, 'The History of the Theory of Elasticity' (Cambridge 1888); Föppel, 'Technische Meckanik' (Vols. III and V); Webster, 'The Dynamics of Particles and of Rigid, Elastic and Fluid Bodies' (Leipzig 1904); Reimann-Weber, 'Die Partiellen Differential Gleichungen' (Vol. II, Braunschweig 1901).

R. F. DEIMEL,

Assistant Professor of Mechanics, Stevens Institute of Technology.

**ELASTIN**, an insoluble proteid substance, of which the elastic fibres of connective tissue are composed. It may be conveniently prepared from the *ligamentum nuchæ*, by boiling with ether and alcohol (to remove the fats) and afterward by prolonged boiling, successively, with water, strong acetic acid and concentrated caustic soda and subsequent successive treatment with weak acetic acid, water, hydrochloric acid and water. When so prepared, elastin is not soluble (without decomposition) in any known solvent. It dissolves with decomposition in concentrated sulphuric acid, however, yielding leucin, but not tyrosin. Elastin is digested both by pepsin and by trypsin and it contains no sulphur. Its percentage composition, according to Muller, is C=55.45; H=7.41; N=16.19; O=20.89.

**ELATEA.** See CITHÆRON.

**ELATER**, ěl'á-těr, a genus of beetles in the pentamerous sub-order, type of the family *Elatridæ*. They are familiarly known as "click-beetles" or "skip-jacks," from their habit of jerking themselves with a slight noise into the air when they land or are placed on their backs. The body is arched upward and suddenly straightened with a violent muscular exertion, which lifts the animal from the ground. The legs are too short for the ordinary method of righting the body. The larvæ are only too familiar as "wireworms." Some tropical forms are phosphorescent. See FIRE-FLIES.

**ELATERIDÆ**, ěl-a-těr'i-dē, a family of *Coleoptera* (click-beetles), tribe *Pentamera*, sub-tribe *Sternoxia*. It contains the insects placed by Linnaeus in his great genus *Elater*, now broken up into many genera. See FIRE-FLIES; ELATER.

**ELATERIN**, a neutral chemical substance having the formula  $C_{20}H_{20}O_2$ , and obtained by alcoholic extraction of the greenish precipitate thrown down by the juice of the slightly unripe squirting cucumber, *Ecballium elaterium*. It crystallizes in hexagonal tablets which melt at 400° F. and are insoluble in water, but soluble in chloroform and in hot alcohol. Elaterin has a bitter taste and is a powerful purgative, the dose being from the 40th to the

10th of a grain. A crimson color, changing to a scarlet, is produced when sulphuric acid is added to a solution of elaterin in carbolic acid; this reaction serving as a test for its presence.

**ELATERITE**, an elastic, asphalt-like mineral, known as "elastic bitumen." In color it is dark brown, with a specific gravity ranging from 0.9 to 1.2. It occurs abundantly in Derbyshire, England, and a mineral closely allied to it has been found at Woodbury, Conn.

**ELATERIUM**, ěl-a-těr'i-um, a mixture of principles formed as a precipitate, occurring spontaneously in the juice of the fruit of the wild or squirting cucumber, *Ecballium elaterium*, the active principle of which is elaterin. The squirting cucumber is a small perennial, of the cucumber family, indigenous in Persia, India and the warmer Oriental countries, and has been extensively cultivated even as far north as England. The fruit itself is 1½ to 3 inches long by 1-3 to 3-4 of an inch, oblong or oval in shape, covered with soft bristles and yellowish green in color. It is firm externally. As the fruit ripens fermentation takes place in the interior with the formation of gas. This accumulates in sufficient quantities to exert considerable pressure, bursting the fruit at its base and squirting the seeds some distance. In this manner the fruit is distributed. Elaterium has been used for centuries as a cathartic, the phenomena of the squirting seeds having suggested its function. Elaterin itself is a neutral principle of the formula  $C_{20}H_{20}O_2$ . It forms in minute white prismatic crystals, without odor and with a slightly gritty and bitter taste. Elaterin is one of the most active of all the hydragogue cathartics. It operates with violence even in minute doses. It is particularly of service in conditions in which there is general dropsy and no inflammatory condition of the intestinal tract. Elaterin is given in doses of from 1-40 to 1-10 of a grain.

**ELBA**, Italy (Lat. *Ilv*; Gr. *Ætalia*), small island in the Mediterranean Sea, off the coast of Tuscany, and with several much smaller isles, lying at the mouth of the Gulf of Piombino. The island of Elba is 18 miles from east to west, with a width varying from 2½ to 12 miles in its widest part. The mountainous districts of the island yield large quantities of superior iron, copper, tin, lead, marble, lode-stones and alum, besides wines and fruits. Tunny and sardine fishing and the extraction of sea salt are other important industries. On the first abdication of Napoleon in 1814, Elba was assigned to him as a residence and empire. Here he accordingly took up his residence, in the month of May; and on 26 Feb. 1815, he secretly left the island, and, landing in France, began that brief and final career, known in history as the "Hundred Days." During his sojourn here Napoleon lived at the Villa San Martino in the town of Porto Ferrajo. It still stands. He caused a road to be constructed between Porto Longone and Porto Ferrajo. Elba has had a chequered history; it belonged successively to Pisa, Genoa, Sora and Piombino. After 1815 it was given back to Tuscany, and in 1860, with the latter it became part of the Kingdom of Italy. Consult Fatichi, 'Isola d'Elba' (Florence 1885). Elba was a place of celebrity in the time of the Romans, and famed

then, as now, for its yield of iron. It has a mild and healthful climate and the soil is fertile. Mining, however, occupies the attention of the inhabitants to the exclusion of agriculture. Two good ports are Porto Ferrajo and Porto Longone, both well fortified. Pop. 25,480.

**ELBASSAN**, el-bas'sān, Albania, town on the Scumbi, 35 miles east of its mouth. It stands in the centre of a fertile plain and nearby are a number of hot sulphur springs. There are small manufactories of iron and copper. Pop. about 15,000.

**ELBE**, ēl'bē (ancient **ALBIS**; Bohemian, **LABE**), a river of Germany, one of the largest in Europe. It rises on the southwest slopes of the Schneekoppe or Snowcap, one of the Riesengebirge, between Bohemia and Silesia. From this point it flows nearly due south into Bohemia for about 50 miles, when it turns to the west, and after about 40 miles takes a general north-northwest direction till it empties into the North Sea, intersecting Saxony, a considerable portion of Prussia, and in the latter part of its course separating Holstein on its right from Hanover on the left. The length, including windings, is upward of 780 miles. The principal affluents are on the right, the Iser, Schwarz-Elster and Havel; on the left, the Alder, Moldau, Eger, Mulda and Saale. In the lower part of its course the river is divided by five large and seven small islands into several arms, which unite again about five miles below Hamburg. The mean depth is 10 feet, average breadth 900 feet. It is more or less navigable for about 470 miles, but its estuary at Cuxhaven is much encumbered with sandbanks. It is well stocked with fish. On 1 July 1870, the navigation of the Elbe was declared free from Hamburg to Melnik in Bohemia. There is an important system of canal navigation in connection with the Elbe, Hamburg, for instance, being in this way connected with Berlin.

**ELBERFELD**, ēl'bēr-fēld, Germany, town in the Prussian Rhine province, 15 miles east of Düsseldorf, in the beautiful valley, and on both sides of the Wupper, enclosed by lofty hills. It has no historical or antiquarian importance. Its prosperity has been acquired mostly within the last century and is due to the cotton manufacture, of which it is the central locality in Rhenish Prussia. The old town was irregularly built with a maze of narrow streets, but the new portion has fine modern streets with buildings of the latest style bordering them; the principal of these are the courthouse and the Rathaus. The city has some fine public monuments. It is an important industrial centre, especially dealing in textiles, their manufacture and dyeing. In addition to cotton, silks, woolens, etc., it manufactures chemicals, leather, furniture and carpets, firearms, rubber goods, paper, machinery and glass. It is also a great commercial centre and has many foreign consulates. It contains a gymnasium, polytechnic school, school of industrial drawing, an institute of music and a school for mechanics. Seven railroads serve the city and in addition there are electric roads to nearby centres. During the Middle Ages the town grew around Elberfeld Castle and became a city in 1610. Silk manufacturing and dye-works were introduced toward the close of the 18th century and there-

after Elberfeld grew rapidly. It was early part of the Duchy of Berg and in 1815 was united to Prussia. It has a unique poor-relief system, which has been copied in many parts of the world. Pop. 170,195. Consult Schnell, 'Geschichte der Stadt Elberfeld' (Elberfeld 1900); A. Shadwell, 'Industrial Efficiency' (London 1906); Jorde, 'Führer durch Elberfeld und seine Umgebung' (Elberfeld 1902).

**ELBERFELD SYSTEM**, a system of poor-relief which originated in the appointment of six visitors in 1800, to investigate applications for aid, in the manufacturing town of Elberfeld, Prussia. The city was subsequently divided into districts, the number of visitors was increased and the operations developed, until by 1852 what has become known universally as the Elberfeld System was adopted. Its main features are the division of the city into 26 districts subdivided into 364 precincts, each precinct being administered by an almoner who investigates each application, in case of emergency provides immediate assistance and as long as aid is afforded, visits the applicant twice a month. Money relief is granted fortnightly according to a fixed schedule, any earnings in the meantime being deducted; when needed, working implements are provided. A meeting of the almoners under the presidency of an overseer takes place every fortnight to discuss cases and to vote necessary relief, a report of the meeting being laid the next day before the directors who are chosen from four councilmen and four citizens with the mayor as chairman ex officio. The directors superintend and advise on the whole city's work. The positions of almoners, overseers and directors are of a purely honorary character. The advantages of the system in the improvement of the condition of the poor have been strongly apparent, the ratio of persons assisted in 1889 being 7 per 1,000 as against 17 per 1,000 in 1855. See also **CHARITIES**.

**ELBERON**, N. J., sea-coast summer resort in Monmouth County, on the Pennsylvania and the Central Railroad of New Jersey. Pop. about 250. Here President James A. Garfield (q.v.) was taken after he was shot by Guiteau, 6 Sept. 1881, and died here 19 Sept.

**ELBERTON**, Ga., city and county-seat of Elberton County; on the Southern and the Seaboard Air Line railroads; 90 miles northeast of Atlanta. It is in a cotton-growing section and the chief industries are connected with the cultivating, shipping and manufacturing of cotton. It contains manufactories for cottonseed-oil, cotton goods, compressing cotton, fertilizers, harness, carriage and wagon shops, ironworks, etc. The quarries nearby give employment to a number. The city contains a public library and owns the waterworks and electric-lighting plant. Pop. 6,483.

**ELBEUF**, ēl'béf, France, town in the department of Seine-Inférieure, 11 miles south-southwest of Rouen, situated in a beautiful valley on the left bank of the Seine. It contains two great churches, Saint Stephen's and Saint John the Baptist's, both of which have fine ornamental glass. In the town and also in the nearby communes there are several cloth manufactories, mostly flannels, double-twilled cloth and waterproofed cloth and light woolens. There are schools for instruction in all the

branches of the local industry. Until the revocation of the Edict of Nantes there were upward of 60 cloth manufactories here, but the dislocation caused at that time was not remedied until 1790, and the industry did not recover fully until about 1840. Pop. 18,290.

**ELBING**, Germany, seaport town, in West Prussia, on the Elbing, near its entrance into the Frisches-Haff, 32 miles east-southeast of Dantzic. It is divided into the old and new towns, the former of which was once surrounded by turreted walls and gates, but these for the most part have been removed. It has shipbuilding yards, which do a considerable trade in building and repairing vessels. Its manufactures include machinery, chicory, lumber, flax and hemp yarn, woolen and cotton cloth, leather, soap, tobacco and beer as well as trade in agricultural products. There are also oil manufactories, iron foundries, dye and print works and the famous Schichau shipbuilding works for the construction of war vessels. Elbing has excellent railway facilities and is in steamboat communication with Dantzic and Königsberg. By means of a canal it has connection with the Vistula, and the harbor was improved by the opening in 1884 of a mole 3,500 yards long. The town was founded in the early 13th century by colonists who were natives of Bremen and Lubeck. The town grew up around the fortress of the Teutonic Knights. It became a Hanse town but Poland took it in 1454. During the religious wars the place was in turmoil and also suffered much during the wars between Poland, Russia and Sweden. In 1772 it was annexed to Prussia. For many decades it declined but within the present generation has once more become a thriving centre. Pop. 58,636.

**ELBOW**. See **ARM**.

**ELBOW JOINT**. See **ARM**.

**ELBOW PIECES**, a mediæval armor, the plates used to cover the junction of the pieces which covered the upper and lower half of the arm. These plates were mostly disc-formed, cup-formed, or articulated. Consult Ashdown, 'Arms and Armor' (New York 1909).

**ELBRUZ**, ɛl'brooz, or **ELBURZ**, (1) A mountain range of Persia, running for 450 miles along the southern border of the Caspian Sea. It has a number of subordinate parallel ridges, enclosing extensive and fertile valleys; and unlike most Persian ranges, it has numerous prominent spurs, the highest peak being Mount Demavend (q.v.). The principal traversing river is the Kizil Uzen, which flows into the Caspian Sea. The average altitude is 5,000 feet. (2) Elbruz is also the name of the loftiest summit of the Caucasus.

**ELCESAITES**, ɛl-sɛ'sa-its, or **ELKESAITES**, a sect founded in the 2d century, during the reign of Trajan. They derived their belief from the teachings of the Book of Elkesai, supposed to have been inspired by an angel. Their system seems to have been a commingling of Oriental philosophy with Sudaism and early Christianity, probably put into practice with the idea of satisfying the want of those persons seriously troubled by the religious chaos of the day caused by the mighty conflict of greater creeds. The followers of Elkesai or Elxai are often confounded with Ebionites (q.v.). The

best account we have of the Elcesaites is given by Hippolytus in his chief work, 'Philosophumena.'

**ELCHE**, ɛl'chā, Spain, town of the province of Alicante, 13 miles southwest of the town of that name, on the railway joining Alicante and Murcia. The surrounding groves of palm trees supplies all Spain with palm leaves for Palm Sunday, and the dates are exported in large quantities. There is also a trade in pomegranates. Brandy, oil, woolens, shoes and sandals of esparto grass, mats of the same material, soap and leather are the principal manufactures. The town has a fine, lofty-domed church, a bishop's palace and a hospital. Elche is of Roman origin and was early a place of importance. In the middle of August every year Elche is the scene of a mediæval religious drama—'La Festa ó Misterio de Elche.' In some respects it resembles the 'Passion Play,' at Oberammergau and deals with the Assumption of the Virgin Mary. For the festival consult Paris, Pierre, 'Les Fêtes de l'Assomption à Elche, l'Espagne' (in *Le Correspondant*, Vol. CXCII, p. 156, 1898). Elche has a population of about 30,000.

**ELCHINGEN**, ɛl'ning-ən, Bavaria, village on the Danube, nine miles northeast of Ulm, which gave the title of Duke of Elchingen to Marshal Ney, who here defeated the Austrians 14 Oct. 1805. In the neighborhood are the ruins of a Benedictine Abbey of the same name, founded in 1128. There are two villages, Ober and Unter Elchingen, the former on the same hill with the abbey, the latter to the northeast of it. The hill on which the abbey stood was occupied by Mack, who had his headquarters in Ulm; while Ney, on the right bank of the river, repaired the bridge of Elchingen, forced the passage of the river, and took Elchingen by storm.

**ELDER**, John, Scottish engineer: b. Glasgow 1824; d. 1869. Educated in Glasgow, he was first employed as director of the drawing office of Napier's establishment, becoming later a member of the great ship-building firm which was known after 1860 as Randolph, Elder & Company, employing more than 4,000 men. His fame rests upon his invention of the compound or combined high and low pressure engines, saving nearly 40 per cent of fuel.

**ELDER**, William Henry, American Roman Catholic prelate: b. Baltimore, Md., 22 March 1819; d. 31 Oct. 1904. When 12 years old he entered Mount Saint Mary's College, Maryland, and at 18 was graduated and sent to Rome, where he was ordained priest 29 March 1846. Returning to America, he accepted the professorship of theology at Mount Saint Mary's, became its president, and remained here until consecrated bishop of Natchez, 3 May 1857. On one occasion, when the Federal authorities, who had taken possession of the city, bade Bishop Elder offer certain public prayers and command his clergy to do likewise, he stoutly refused, declaring that in thus ordering him they were usurping the right of religious liberty, and rather than comply he accepted imprisonment; when the case was reported at Washington he was promptly released. In 1878 Natchez was visited by an epidemic of yellow fever and the bishop fell a victim to the plague, which carried him to the point of death.

In 1880 he left Natchez to assume the duties of coadjutor to Archbishop Purcell, of Cincinnati, Ohio, who at once retired, leaving Bishop Elder to settle the perplexing difficulties that disturbed the diocese. Upon the death of Archbishop Purcell, in 1883, Bishop Elder succeeded to the archbishopric of Cincinnati.

**ELDER**, *Sambucus*, a genus of shrubs or small trees and a few perennial herbs of the natural order *Caprifoliaceae*. There are about 20 widely distributed species characterized by opposite, pinnate leaves, small white flowers usually in compound cymes, and black, red, white or green, juicy fruits (berries or drupes). Many of the species are used in ornamental planting, since they are readily propagated by root and stem cuttings, succeed well upon nearly all soils, are of rapid growth, graceful form, and are attractive both in flower and fruit. The best-known species in America is *S. canadensis*, the common or sweet elder, which is frequently seen in fence-rows, along roadsides, and on the margins of woods throughout southern Canada and the greater part of the United States. It attains a height of 10 feet or more, bears abundant fragrant flowers in midsummer and black berries in early autumn. These fruits are used where they can be obtained plentifully for making pies and elderberry wine. Several horticultural varieties have been introduced for their golden or variegated foliage, and one variety with large fruits was introduced in 1890. The flowers are used for making a wine, a perfume, and a "water" used in confectionery. Economically this species ranks as a minor fruit. Like some other members of its genus, it has also been used in medicine, but is rapidly giving place to other drugs. Probably *S. nigra*, the common European elder, ranks next in importance. It is much larger, often attaining a height of more than 20 feet. The yellow, hard, tough wood is readily polished and is used for making skewers, fishing-rods, needles for making fish-nets, and as a substitute for boxwood. It is also employed for the same horticultural and economic purposes as the preceding species, and has numerous fancy-leaved varieties. Other well-known species are the scarlet elder (*S. racemosa*), an Old-World species, and the red-berried elder (*S. pubens*), a native of North America, considered by some botanists to be identical. There are also several unrelated plants which are popularly known as elder, as box elder (*Negundo aceroides*), wild elder (*Aralia hispida*), also known as bristly sarsaparilla, and marsh-elder (*Iva frutescens*).

**ELDERS**, in certain churches, a body of men elected by the communicants from among their number to aid the minister in portions of his work. With the minister, they constitute the executive body of the congregation. Among the Jews the elders were the rulers or magistrates of the people. The instinct of mankind considers the old fitter than the young to rule, and at first probably every "elder" was really pretty well advanced in life; but the designation ultimately came to be used more of office than of age. "The elders of the congregation," or simply "the elders," are mentioned as early as Lev. iv, 15. Seventy of them were appointed as associates of Moses (Num. xi, 16). They are combined with the officers (Deut. xix, 12), with the princes (Ezra x, 8),

with the priests (Lam. i, 19). In the New Testament they are described as having given currency to traditions (Matt. xv, 2), and taken a chief part in compassing the death of Jesus (Matt. xxvi, 59; xxvii, 20), etc. There were elders, also, of single towns, as of Succoth (Judges viii, 14), and of Jezreel (2 Kings x, 1). The churches of the Reformation found this form of lay assistant well adapted to their systems of church government. Where the Church and State have some interrelation, the election of such officers is regulated by civil law. In the Baptist churches, the pastors were called elders, but the name came to be applied exclusively to the missionaries later on. In the Presbyterian Church, the ruling elders have the function of assisting in the government of the Church, under the supervision of the Presbytery. In the Dutch and German Reformed churches, the elders and deacons assist the clergyman and there is also a ruling elder. The Methodist Episcopal Church has a similar office, but the ruling elder is an ordained clergyman appointed by the bishop. The Shakers have four elders, two male and two female. The elders in the Mormon Church are the Melchizedek priesthood. The apostles, the seventy, the patriarchs and the high priest are included in their number, and it is their duty to preach, ordain other priests and deacons, to lead meetings, baptize and bless.

**ELDON**, John Scott, 1st EARL OF, English jurist and Lord Chancellor: b. Newcastle, 4 June 1751; d. London, 13 Jan. 1838. He was educated at Oxford, at University College, receiving his M.A. in 1773. In 1771 he won an English prize by his essay on 'The Advantages and Disadvantages of Travelling into Foreign Countries.' He had intended taking clerical orders, but gave up the idea in order to marry Elizabeth Surtees, the daughter of a wealthy banker of Newcastle-upon-Tyne (1772). Scott was readmitted to the university and entered the Middle Temple in 1773, where he began the study of law and supported himself by tutoring. His success in the law was rapid. He became a member of the bar in 1776, a bencher in 1783, and in the same year was made one of the king's counsels. His sound knowledge of the law atoned for his ineffective oratory and he entered Parliament in 1783, where he soon made his mark as an independent and serious thinker. He supported the Pitt ministry and in 1788 was knighted. In the same year, he was made solicitor-general. On Thurlow's dismissal from the new Parliament he offered his resignation to Pitt, but was induced to return, and in 1793 succeeded Sir Archibald MacDonal as Attorney-General. His association with the rigorous administration made him exceedingly unpopular. His measures in the state trials, his strict interpretations of the treason laws and the vigorous laws he assisted in promulgating heightened the effect of his severity. In 1799 he was chosen to succeed Sir James Eyre as lord chief justice of the Common Pleas, and also became sergeant-at-law and a member of the privy council and board of trade. He was also raised to the peerage as Baron Eldon of Eldon, in the county of Durham, where he had bought an estate. He became Chief Justice in 1801, and Lord Chancellor of England. Throughout the king's illness he

administered affairs with great surety and force. After the death of Pitt, he was forced to withdraw, but was returned in 1807 in the Portland administration, where he soon became the foremost member of the Cabinet. He bent all his able energies to the subjugation of Napoleon. He was the king's strongest adherent and served him with all his powers. In 1811, when the king's lunacy became chronic, Eldon immediately undertook to gain the confidence of the prince. In spite of attacks by his enemies, he succeeded and by assisting in the formation of the Liverpool cabinet, re-entrenched the Tory policies. He arranged for the marriage of the Princess Charlotte with Prince Leopold of Saxe-Coburg. His resistance to the queen's plans rendered him again unpopular with the mass of people, but gained him the loyalty of the Prince, who just before his coronation as George IV bestowed on him the titles of Viscount Encombe and Earl of Eldon. However, this marked the highest point of his career. After the death of the queen, Canning's party came into power and Eldon resigned from the Cabinet. He continued to take an interest in politics and his opinions were highly esteemed by his fellow Tories. He survived to take oaths of fealty to Queen Victoria.

Eldon was an able jurist and administrator, of fascinating personality and an agreeable companion. His faults lay in his adherence to the strict letters of the law, his sophistry and his insistence on hair-splitting definitions and distinctions. His decisions were never hasty nor ill-founded. Consult Townsend, 'Lives of Twelve Eminent Judges' (London 1846); Twiss, 'Life of Lord-Chancellor Eldon' (ib. 1844); Surtees, 'Sketch of the Lives of Lords Stowell and Eldon' (1846); Campbell, 'Lives of the Chancellors' (1874).

**ELDORA**, Iowa, city, county-seat of Hardin County, near the Iowa River, on the Iowa Central, and the Chicago and Northwestern railroads; 122 miles west of Dubuque. The city is the seat of the State Industrial School for Boys, has a Carnegie library and a public park. Agriculture and stock-raising are its chief interests, but fire and brick clay and coal are found nearby. It has manufactures of brick, tiles, flour, foundry products and lumber. The waterworks are the property of the municipality. Pop. 1,995.

**ELDORADO**, Ill., city in Saline County, eight miles northeast of Harrisburg, on the Cleveland, Cincinnati, Chicago and Saint Louis, the Illinois Central, and the Louisville and Nashville railroads. It has coal mines, flour mills, bottling works, a machine shop and foundry, lumber yards and manufactories of medicines, candy, cigars and brick and tile. Pop. 3,366.

**ELDORADO** (from the Spanish *El Dorado*, the Gilded Man), the region of undiscovered treasure in South America. In the article **DABAIBA** we have traced the famous Eldorado myth back to those stories which, at the beginning of the 16th century, were current among the Indians of Darien about 'a temple lined with gold,' and have shown why the Spanish explorers failed to recognize in distant Cuzco, with its temple of the sun-god, the real basis of such accounts. The *name* Eldo-

rado, however, with which the ever-receding or shifting territory, the subject of all those stories, has been stamped, was at first not the name of a place but of a person; and the name-giving addition to the myth is localized very precisely in the table-land of Bogotá, as follows: Lake Guatavita (north of the present capital of Colombia and nearly two miles above sea-level) was regarded by Indian tribes dwelling in that neighborhood in the 15th century as a holy place, and pilgrims who resorted to it often cast their offerings of gold and emeralds into its waters. Whenever a new chief of Guatavita was chosen, nobles and priests of his tribe bore him to the lake, as Mr. Bandelier (in work mentioned below) has written 'upon a barrow hung with discs of gold. His naked body was anointed with resinous gums and covered all over with gold-dust.' The chief plunged into the lake; spectators made the usual offerings of gold and jewels; and, on the conclusion of this ceremony of consecration, the new ruler and his subjects went down to dance and feast in Guatavita village. The Chibchas (q.v.) conquered Guatavita about the end of the 15th century, and under their general government this extraordinary local custom had been discontinued for a number of years before the first Spanish settlements were made on the Caribbean coast—there was no longer an independent Guatavita chief to signify his acceptance of the local religious beliefs in a fashion so dramatic; but native folk-lore continued for a century, at least, to make much of this glittering symbolic figure and the sacred lake. In 1529, Dalfinger, governor of the German colony in Venezuela, set out from his little capital of Coro, and probably reached the edge of the high plain of Bogotá by way of the Magdalena River; there the resistance of the Indians obliged him to turn back. Four years later the report of the vast treasure secured by the conquerors of Peru (Atahualpa's 'ransom' alone was officially valued at 3,933,000 ducats of gold and 672,670 ducats of silver) appeared to justify ventures undertaken in reliance upon the wildest Eldorado tales. It is also true that a fresh outbreak of the gold-fever affected the Spanish colonists everywhere in America, more or less, but especially those in the agricultural settlements; and that leaders of those colonies, in order to retain their men, were obliged to make fresh efforts to find treasure. In Santa Marta, an expedition was organized to ascend the Magdalena River to the highlands; at Coro, Georg von Speyer organized a campaign for the exploration of the Meta plain, far inland. The former expedition under command of Quesada in 1537 reached the old home of the gilded chief; and although Guatavita either hid its gold or was actually poor (40 years having passed since it had ceased to be a place of pilgrimage), the treasure collected in this neighborhood, principally at the villages of Tunja and Iraga, was officially valued at 246,676 pesos in gold, or about \$1,200,000, besides 1,815 emeralds. Von Speyer went astray among the tributaries of the upper Orinoco, but his lieutenant, the German, Nicolaus Federmann, leading a company from Coro, reached the Bogotá highlands in time to meet there not only Quesada but the conqueror of Ecuador Benalcazar, who came up from the south, having also heard the



story of the Gilded Man. Each of these leaders considered himself the discoverer of the country, and they proceeded together to Spain, to submit their claims to the Spanish court, leaving their forces to hold the Eldorado which had been despoiled by the Chibchas, ransacked by themselves.

We are, therefore, unable to agree with the distinguished American archaeologist when he says that, after this time, "Transplanted by the over-excited imagination of the white men, the vision of the *dorado* appeared, like a mirage, enticing, deceiving, and leading men to destruction on the banks of the Orinoco and the Amazon." His "Gilded Man" had been located, and that part of the myth was buried. Subsequent explorations were planned to discover rich countries which were Eldorados only in the modern sense of the word; and we find that the word was used with nearly its present signification at the time when the Amazon River received its name. The legend is especially noteworthy in connection with the history of the Venezuelan settlement under the direction of the German Welser. Having received the province from the Spanish crown practically as a mortgage security for money loaned, Welser and his associates tried to recover the advances they had made from the revenues of the district; and since the coast lands were found to be less profitable than they had expected, they engaged in one Eldorado expedition after another. Dalfinger, Federmann, and Von Speyer have been mentioned; before the utter ruin and failure of the colony at Coro, Von Hutten's expedition penetrated to Omagua, a region near the Amazon, west of Rio Negro and the Cassiquiare. The Spanish conquerors of Peru and Ecuador were led by the search for further stores of wealth to make the most important geographical discoveries east of the Andes. Gonzalo Pizarro set out from Quito to explore the forests (1539-42), hoping to find spices there, and also "wealthy regions in which the people went around adorned with gold." His lieutenant, Francisco de Orellana, with 53 men in a bark, becoming separated from the main body of the expedition, went on down the Amazon to its mouth. The Dominican Carvajal, Orellana's chronicler, relates that women took part in the fighting against the Spaniards, and that a captive Indian spoke of a tribe of Amazons rich in gold living north of the river. (Compare Prescott's 'Conquest of Peru,' II, 164-65, note). Wandering Indians brought to Peru about the middle of the 16th century reports of countries rich in gold and silver, which lay far eastward; and the viceroy made use of the Eldorado fever thus excited to rid Peru of a large number of disorderly persons. In 1560 a company of criminals and desperadoes, with women, set out from Santa Cruz de Capacoba, proceeding in boats, canoes and even upon rafts, down a tributary of the Amazon, under the leadership of Pedro de Ursua. In January 1561, Ursua was murdered by conspirators and eventually Aguirre, chief conspirator, transformed the remnant of the expedition into a piratical band; captured the island of Margarita and invaded Venezuela. At least four Eldorado expeditions proceeded from the north coast toward the interior before the end of the century, in addition to that one which Sir Wal-

ter Raleigh led in 1595. Consult Bandelier, A. F. A., 'The Gilded Man' (New York 1893); and Brinton, D. G., 'The Myths of the New World' (New York 1868 and 1896).

MARRION WILCOX.

**ELDORADO SPRINGS, Mo.**, city in Cedar County, 100 miles southeast of Kansas City, on the Missouri, Kansas and Texas Railroad. The principal industry is the bottling of water from the mineral springs. Farming and stock raising are carried on also. The water-works are owned by the municipality. Pop. 2,503.

**ELDRIDGE, Shaler W.**, American abolitionist: b. West Springfield, Mass., 1817; d. Lawrence, Kan., 17 Jan. 1899. He removed to Kansas in 1855, and became proprietor of the American House in Kansas City, soon recognized as the headquarters of Free-soilers. In 1856 Eldridge opened the Free-State Hotel in Lawrence, but soon afterward a pro-slavery court issued a writ of indictment, declaring the place a nuisance, and it was destroyed by a posse led by Sheriff Jones. This occurrence caused great excitement among the Free-soil men, who commissioned Eldridge to visit Washington with a petition in their behalf and also to sit in the convention that nominated Fremont. Later he became a member of the National Republican Committee and agent to promote immigration into Kansas. Under the last authority he led a large number of settlers to Kansas. During one of these trips, with a party of 350 men, he was taken prisoner by United States troops. Subsequently he recruited a party of Free-soilers, who retook the arms from the United States officers at LeCompton. He was instrumental in giving much aid to the Free-State cause by smuggling large amounts of ammunition and provisions into Kansas Territory. During the Civil War he served in the Union Army.

**ELD'S DEER**, a deer (*Cervus eldi*) native to the Malayan region. It is about four feet tall, lives in swampy places and is often found in large herds. Its habits are like those of the Indian swamp-deer. The antlers are peculiar in that the brow-tine sweeps down over the forehead and that the upright part has numerous points.

**ELEANOR OF AQUITAINE**, queen of France and afterward of England: b. 1122; d. Fontevrault, France, 1 April 1204. She was the eldest daughter and heiress of William IX, Duke of Guienne or Aquitaine, and was married 2 Aug. 1137, to Prince Louis, who in the same year succeeded to the throne of France as Louis VII. She was gay, frivolous, a lover of poetry and art, and could not sympathize with the ascetic spirit of her husband. She accompanied him on the second crusade to the Holy Land in 1147. At that time he complained of her preference for other men, and on their return from Asia they were divorced 18 March 1152. A short time afterward she bestowed her hand upon Henry Plantagenet, the future Henry II of England. This alliance, which made Henry master of Eleanor's vast possessions in France, produced pernicious and protracted wars between France and England. She bore him many children, but his infidelities and neglect changed her love into hatred. She

incited her sons Geoffrey and Richard Cœur de Lion to rebel against their father, was imprisoned in 1174, and remained in confinement until after Henry's death in 1189, when she was released by his successor, Richard I, who placed her at the head of the government on his departure for the Holy Land. She negotiated his marriage with the daughter of the king of Navarre, and went to Germany with his ransom from captivity. She afterward retired to the abbey of Fontevrault and surviving Richard, lived to see him succeeded by one of her other sons, John Lackland, the signer of Magna Charta. She was a favorite personage with the troubadour poets of the day and appears in a very different light in their works from that in which she is represented by French and Norman chroniclers. Consult Adams, 'History of England, 1066-1216' (London 1905).

**ELEANOR CROSSES**, memorials of Eleanor of Castile. She was the wife of Edward I of England, and d. Lincolnshire 1290. Her body was taken to London by her sorrowing husband who subsequently erected a monument, terminating in a cross, at every spot where her funeral train had rested. These places were Lincoln, Grantham, Stamford, Geddington, Northampton, Stony Stratford, Woburn, Dunstable, Saint Albans, Waltham, East Cheap and Charing Cross, but the list varies slightly as given by different authorities. The crosses at Geddington and Waltham remain, although considerably altered by restoration in the latter case. That at Charing Cross, destroyed in 1647, was replaced in 1863 by a new one reproducing the original.

**ELEATICS**, ē-lē-āt'iks, a Greek sect, so called because founded at Elea, in Sicily, by Xenophanes of Colophon, about 538 B.C. Zeno, who flourished 464 B.C.; Empedocles, 435 B.C.; and Melissus 428 B.C., were leading philosophers of this school. That which from the commencement distinguished the Eleatic school from the Ionic was its method, which in the one case was dialectic, in the other empirical. Starting from the observation of external nature, the Ionians endeavored to discover some elementary principle, as water, air, fire or a combination of elements, by the action of which the phenomena they observed might be accounted for. The Eleatics made the abstract idea of Being or God, deduced from the contemplation of the universe as a whole, their starting-point; and their reasonings sometimes led them to deny the reality of external phenomena altogether. This was the result of the development which the principles of Xenophanes received from his followers Parmenides and Zeno, the latter of whom denied the existence of variety in any form. See also IONIAN PHILOSOPHY; IONIAN SCHOOL; XENOPHANES; ZENO. Consult Windelband, 'History of Philosophy.'

**ELECAMPANE**, ēl-ē-kām-pān' (*Inula helenium*), a plant of the sunflower family (*Compositæ*). The stem is three or four feet high, thick, pubescent and branching above; the radical leaves are often two feet or more in length; the flowers are large and yellow. The plant is a native of Europe and Asia, naturalized in the United States. It grows abundantly along roads and in waste places. The root is perennial

and has a bitter aromatic taste. Elecampane is cultivated occasionally as an ornamental plant and the flowers are sometimes used to adulterate arnica. The root was formerly much employed in medicine, but has fallen into disuse. It contains a number of active principles, the most important being a volatile oil, a camphor, inulin and helenin. By reason of the camphor and the oil the action of the drug is somewhat stimulant and stomachic. Elecampane was once very much used in the treatment of bronchitis and amenorrhœa. As a hot infusion it subserves practically the same purpose as camomile tea, being a good diaphoretic.

**ELECTION**, *in law*, the voluntary choice between two or more permissible lines of conduct. In equity the choice is between two or more alternative rights or claims which were plainly intended by the person who has granted them to be mutually exclusive. In criminal law it is the choice incumbent on the prosecution to proceed on one of a number of independent felonies of the same degree. In the law of wills the widow's election is her choice whether she will make her claim under her husband's will or under the statute, which gives her a right to a specified part of her husband's estate. An election may be explicit and announced, or it may be implicit in the conduct of the person bound or entitled to elect. In neither case is the election binding unless made with a knowledge of all the relevant and material facts; but if these facts are known, the election is final.

**ELECTION**, *in politics*, the mode of determining the person who is to fill an office by the votes of the qualified electors. Alternative methods are selection by someone already in authority or by lot. The electors may be the entire body of those of the citizens of the region concerned who fulfil certain very general requirements, as is the case in the various State elections for governor or the election of senators and representatives, or may be some relatively small body of officials, as in the "indirect" election of senators by the State legislatures, which was alone legal until 1913, when the Seventeenth Amendment to the Constitution was ratified. In the case of the elected kings of Poland and Hungary and of the Holy Roman emperor, the election was in the hands of a greater or smaller group. The election of the President of the United States, though nominally entrusted to a representative body of men—the electoral college—is now to all intents and purposes of the direct type, as by custom the electors are mere mouthpieces of the popular vote. The honesty and fairness of elections is secured by stringent laws and by various devices to secure secrecy of the ballot. These are discussed under the head of BALLOT. See also ELECTIONS; CORRUPT PRACTICES ACTS; ELECTORAL FRAUDS AND SAFEGUARDS AGAINST; VOTE, VOTERS, VOTING.

Election is a very old political device. While election by acclamation has always been a recognized means of determining the chief in certain savage communities, it was in the city-states of Greece and in republican Rome that the ballot first became the basis of the government of a highly organized civilized community. This right was limited to some more or less restricted class of free citizens, and was gener-

ally exercised in an open assembly not unlike the New England town meeting—the Ecclesia of Athens or the Roman Comitia. From the period when the empire first made the comitia a mere form and then abolished it altogether to the reappearance of the assembly of the people as a custom of the northern barbarians, election ceased to play any important part in politics. It survived in a measure in the Church and it reappeared in a very limited form as the method of selecting the Holy Roman emperor. The first renaissance of a genuinely popular election after the races of the north had lost almost all memory of their original custom of settling disputes and electing their chiefs in the council of the warriors, was in the form of the election of the officers of the guilds and of the free towns. (See article, ELECTIONS and cross-references thereunder). Consult Aristotle, 'Politics'; Freeman, 'Comparative Politics' (London 1873); Jones, 'Readings on Parties and Elections in the United States' (New York 1912); Stanwood 'History of the Presidency' (Boston 1912); Woolsey, 'Political Science' (New York 1877).

**ELECTION**, in *theology*, the word (singular) is applied to the act of God in selecting some persons from the race of man to be regenerated by his spirit, to be justified, to be sanctified, and to receive other spiritual gifts in this world, with eternal life in the next. The Calvinistic doctrine makes this election take place by God's mere good pleasure, without any foreseen merit in the individuals chosen. The Arminian one considers that God chooses those whom he foresees will accept the offer of the Gospel and act as true Christians till death. The third chapter of the Westminster Confession, entitled "Of God's Eternal Decree," uses more decided language. The strongest adherents of this view are in the Presbyterian churches, though there is a tendency to soften the harsher features of the system. Many Baptists hold the same doctrine, as do the Calvinistic Methodists.

**ELECTION DISTRICT.** See DISTRICT.

**ELECTIONS.** As defined by the courts an election is the act of choosing a person to fill an office by any manifestation of preference but usually by the vote of those entitled to exercise the elective franchise, as distinguished from appointment to office by a single person or officer, as a king, president, governor or mayor. See APPOINTMENTS.

**Classification of Elections.**—If the great body of the voting population decide between candidates, the election is said to be popular or direct. If limited to a small number who themselves have been chosen by the mass of voters, the election is said to be indirect or representative. The choice of United States senators by the State legislatures until the 17th Amendment became law is an example of indirect elections. Theoretically the President is elected by the Presidential electors chosen in the various States but in practice these electors vote for the party candidate. (See ELECTORS, UNITED STATES PRESIDENTIAL). Elections are also classified as national, State and municipal, according to the status of the office to be occupied by the successful candidate.

**Early Colonial Elections.**—From the earliest colonial days, local officials in New England

were chosen in a meeting of the "freemen," much as they are to-day in town meeting. Probably the first elections held in America were of the delegates who attended the Virginia legislative assembly in 1619. The earliest date specified is that of the election of John Winthrop as governor of Massachusetts "by the general consent of the Court," 18 May 1631. The next in order is the election at Plymouth, 1632-33, although elections were authorized in this colony in 1620 and in the colony of Massachusetts in 1630, and undoubtedly they were held from that time onward. A few years later the records show that elections were conducted by proxy, chosen deputies casting the votes of the freemen at the "court of elections." According to some authorities proxies meant usually the carriage of the votes, at first the ballots themselves (slips of paper or grains of corn, etc.), and later the records. The history of the process is hard to interpret. In New Hampshire elections were held from 1633 onward, and in Rhode Island after 1636-38. In Connecticut the earliest election was in 1639; in Maryland 1638. All the southern colonies except Georgia elected assemblies almost from the start, and summonses for one session were issued in Georgia. In New Amsterdam (now New York) the right to elect its own magistrates was long withheld by Director Stuyvesant. "If," he said (1653), "the nomination and election of magistrates were to be left to the populace who were the most interested, then each one would vote for some of his own stamp, the thief for a thief, the rogue, the tippler, the smuggler, for a brother of iniquity, that he might enjoy greater latitude in his vices and frauds." In New Jersey elections did not begin till 1668, although authorized in 1665. The first election in Pennsylvania was in 1683. In the Carolinas the first recorded elections were in 1691, but minor elections probably were held as early as 1663. In Georgia all officials were appointed up to 1754.

**Authority to Hold Elections.**—To be valid an election must have some lawful authority behind it; unless the power be expressly granted by the constitution or by the legislature acting under constitutional authority, the right to hold an election cannot exist or be lawfully exercised. The legislature may prescribe the forms to be observed in the conduct of elections. Laws enacted to ascertain the will of the people at free popular elections may be mandatory (such as those setting the day of election, requiring the vote to be by ballot, or establishing places within the designated precincts where the election shall be held), or directory (such as provisions prescribing the conduct and return of an election). Minor irregularities in observing the directory laws which do not prevent electors from freely and fairly exercising their right of suffrage or from having their votes properly counted do not vitiate an election, providing such irregularities do not constitute infractions which the law declares shall nullify an election. Statutes providing for the holding of a local election usually require the presentation to some local authority of a petition signed by the prescribed number of qualified persons; when properly presented, the authorities appointed to call the election have no discretion and after the order is issued it is not open to collateral attack.

The time and place of holding regular elections are generally appointed in the public laws, and therefore, as electors are supposed to know the law and accordingly would receive notice from the statutes themselves, no proclamation or notice is mandatory, but proclamations for special elections must be issued by the authority named in the statutes and in strict accordance with those statutes. This notice is particularly important in cases of special elections to fill vacancies caused by death, resignation or removal, where the statutes do not require that the vacancy be filled at the next general election. Usually the statutes require that, for a certain time before election day, notices of a coming election shall be published in one or more newspapers or posted in the form of handbills either at the polling places or at a number of public places. In elections to determine specific questions, the notices must fully inform the voters of the questions to be decided and such notices must not only clearly show the authority for the order but also that they themselves have been signed by the proper officers.

**Time and Place of Holding Elections.**—To be legal the time and place of holding an election must be fixed in advance, either by law or by legally authorized officials; and votes cast differently will avail nothing regardless of the eligibility of the candidates voted for. If the time be fixed by general law no other time will be legal, save where the statutes provide for special elections; if the statutes fix the time, no power may adjourn the election to a subsequent day, unless the constitution or statutes permit such adjournment, though legislatures are within their province in postponing elections in order to do away with frequent and unnecessary elections. A slight change in the voting place should not invalidate otherwise properly conducted elections, provided no voter is misled or deprived of his vote by reason of the change. Under some circumstances the voting place may even be outside the election district, but the electors of the district who vote thereat would not be disfranchised on that account. Congress has power to determine the time of choosing the Presidential electors and on 1 March 1792 enacted that the choice should be made within 34 days preceding the first Wednesday in December. On 23 Jan. 1845 Congress enacted that Presidential electors be chosen on the Tuesday following the first Monday in November in each quadrennial year, and later (2 Feb. 1872) provided that, beginning with 1876 members of the House should be elected on the same day in biennial years ("even" years), though some exceptions were allowed under the amending act of 3 March 1875, whereby certain States were permitted to continue holding their elections at an earlier date. Amendment XVII to the Constitution (effective 31 May 1913) provides for the election of senators by the direct vote of the people but makes no stipulation as to the time of election, merely providing that "when vacancies happen in the representation of any State in the Senate, the executive authority of such State shall issue writs of election to fill such vacancies: *Provided*, That the Legislature of any State may empower the executive thereof to make temporary appointments until the people fill the vacancies by election as the legislature may direct." Presumably, there-

fore, elections of senators are held the year preceding the expiration of the incumbent's term of office, the time being designated by the State legislature. Most of the State elections, and in many cases local and municipal elections, are held on the same day as the national election, but in many States minor officials are not elected in the same year as the governor and lieutenant-governor. All the States hold their elections in November with the exception of Louisiana, Maine and Vermont, the election of the first named occurring in April and of the latter two in September. If a vacancy occur in an elective office, the governor of a State may call a special election or hold the choice over until the next regular election.

**Classification of Votes and Voting—Independent, Popular, Preferential, Compulsory.**—See VOTE, VOTERS, VOTING.

**Electoral Qualifications, Colonial and Modern.**—Details respecting the franchise rights and privileges of the various States will be found in the articles ALIENS; CITIZENSHIP IN THE UNITED STATES; ELECTORAL QUALIFICATIONS; NATURALIZATION; UNITED STATES—SUFFRAGE IN THE; VOTES, VOTERS, VOTING; WOMAN SUFFRAGE.

**Terms of Office, Age Limits and Qualifications for Office.**—See ELECTORAL QUALIFICATIONS, TERMS OF AND QUALIFICATIONS FOR OFFICE.

**Party Nominations, Primaries, Etc.**—The four principal methods of choosing candidates are by the delegate convention system, the direct primary, the non-partisan primary, which is used in many municipalities, and nomination by petition only. The term "primary" is usually applied to the preliminary elections held by the political parties to nominate candidates or to choose delegates whose duty is to nominate candidates to compete in the following regular election. In either case party members only are allowed to vote in the primaries. Originally candidates for local offices announced their own candidacy or perhaps were nominated by an informal caucus; the legislative caucus nominated candidates for State offices; and aspirants for the Presidency were nominated by the Congressional caucus (see CAUCUS); but the latter two caucuses were soon discarded and by 1832 the convention system had been generally adopted. (See CONVENTION, POLITICAL). This system was so indirect and complicated and so flagrantly abused that regulation of nominations became imperative and by 1900 party elections had been placed under the same legal restrictions as the regular elections. Beginning with 1900, however, the convention plan has been rapidly supplanted by the direct primary, under which candidates are selected by the direct vote of the party. Some States also allow each party a direct vote on choice for Presidential nominees. (See PRIMARY, DIRECT; PRIMARY, PRESIDENTIAL PREFERENCE; and in this connection see also INITIATIVE; REFERENDUM; RECALL). Under the non-partisan primary (which really is not a primary at all) the whole electorate participates in the selection of candidates later to be voted upon at the regular elections. This system has been developed in connection with the commission form of government (q.v. See also CITY MANAGER) as worked out in Des Moines, Iowa, and other places. The two candidates for mayor and the eight candidates for

the four commissionerships receiving the highest number of votes may participate in the second and final election. In all elections, party emblems, circles, or other designations are prohibited in connection with candidates' names. In some cities (as Berkeley, Cal), if any candidate receive a majority of all the votes cast, a second election is unnecessary so far as that particular office is concerned. In some localities preferential voting has been adopted so that national political parties will be eliminated from local elections. If any number of persons not constituting a political party be entitled to make nominations in the usual way and to have the names of their candidates placed upon the official ballot, they may present to the proper officials a petition containing the required number of signatures of qualified electors and their nominees may enjoy the same privileges on the official ballot as accorded to those regularly nominated by an existing party. Nominations by petition are used chiefly in local elections, and, unless required by statute, no party emblems or designations are used in connection with the names of candidates. Under a law passed in 1907 Wisconsin permits nominations to be made by petition only; but after nominations are filed upon petition of 5 per cent of the electors a preliminary election may be called to select the two candidates for each office and those two only are voted upon at the final election. In many States a declaration of party affiliation is necessary under the primary law. Illinois further prohibits the participation in a primary of anyone who has voted in the primary of another party within the preceding two years. Some States (as New York) use a system of party registration similar to that used for general elections. When the voter registers at that time an opportunity is presented to him to declare his party affiliation, if any, and from these declarations a list of party voters is compiled which is used as the registration for the ensuing primary election. The California law of 1899 and the Oregon law of 1901, which allowed electors to vote for either party without divulging party preferences, were declared unconstitutional. Under the Wisconsin law of 1903 the ballot is absolutely secret and the voter may vote for the candidate of whichever party he may choose, but he may not vote with more than one party at any election. The "open primary" eliminates the party test which is applied in the "closed primary." In the non-partisan primary no party test can be applied since the elector votes for any candidate he may choose regardless of party ties.

**Campaign Expenses and Contributions.**—See CORRUPT PRACTICES ACTS; ELECTORAL FRAUDS; BALLOT; BRIBE; LOBBY; CONGRESS, ETC.

**Voting Districts.**—So that participation in elections may be easy, counties, cities and towns are divided into small precincts or election districts, each containing a few hundred voters and operating under the supervision of an election board. Whether composed, as at different periods and in different States they have been, of counties, cities, townships, boroughs, wards of cities, or of precincts, election districts always indicate subdivisions of the State's territory marked out by known boundaries prearranged and declared by public authority. As nearly as possible, city precincts contain an

equal number of voters; they must be entire wards or contained wholly within one ward or one town and cannot be composed of parts of adjacent wards or districts. The election district, however, is never used as a unit of representation in local government nor as an administrative division in the conduct of municipal business. See DISTRICT.

**Polling Places.**—The law designates the manner of the internal arrangements of polling places so that the voter will have perfect freedom in marking and depositing his ballot. Where the Australian ballot is used, the statutes require that polling places contain booths of sufficient size to accommodate one voter and so constructed that the voter will be screened while preparing his ballot. Booths should be shut off by guard rails and no unauthorized person allowed to go within these confines. In most States no official ballot may be taken outside the polling place. Official ballot boxes are required at all elections, and prior to the opening of the polls these boxes must be opened for public inspection. During primaries and elections the polls are policed in accordance with the law (though the presence of a police officer at each polling place is not authorized by express statutory provision), and in some cases election officers may exercise the authority of justices of the peace and punish election offenders. Stringent laws have been passed in many States to protect the voter from undue influence while in the act of voting. In most States electioneering is prohibited within a certain distance from the polling place; in some States polling places must be a certain distance from saloons; and in the advanced States saloons are closed on election days. Oregon requires that no "political badge, button, or other insignia shall be worn at or about the polls on any election day."

**Registration of Voters.**—All persons possessing the constitutional qualifications of electors may be and in nearly all the States must be officially registered on the voting lists in the districts wherein they reside in advance of each election, the period varying in the several States. If a State constitution or statute make registration a specified time before election day an imperative prerequisite to the right to vote, those not so registered cannot vote even if their other qualifications comply with constitutional requirements. Nevertheless the courts have held several times that even if a person be not a qualified voter under the constitution on the day the registration books are closed, yet if he acquire the necessary qualifications before election day his vote cannot lawfully be rejected merely because he has not registered. While the constitutional qualifications must be left intact, without excisions or additions, the legislature may prescribe regulations to determine if the prospective voter possess the required qualifications; hence the passage of a registry law requiring registration as a condition precedent to the right to vote is not unconstitutional; where such a law exists an election held without such registration is void, but if the State constitution provide that the legislature shall enact a registration law and the legislature fails to do so, an election without registration is valid. Arkansas and Texas do not require registration; in Oklahoma registration is required in all cities of the first class;

in Kansas and Ohio in cities of the first and second classes; in Kentucky in cities of the first, second, third and fourth classes; in Washington in all cities and towns and in voting precincts with a voting population of 250 or more; in North Dakota in cities and villages of 800 or more inhabitants; in Maine in cities and towns of over 2,000 inhabitants; in Iowa and Nebraska in cities of 3,500 and 7,000 or more inhabitants, respectively; in Missouri in cities of 100,000 or more inhabitants; and in all cities of Pennsylvania. In all incorporated cities, villages and towns of Illinois which have adopted the election commissioner act of the State, unregistered persons may not vote, but elsewhere they may swear in their votes if they produce a creditable witness to prove their electoral qualifications. In Rhode Island non-taxpayers are required to register each year before 30 June. In the larger cities voters must appear in person before the registering officers, but in rural districts the voter often is registered by official declaration and the registration list is compiled by local authorities, subject to revision on demand of interested parties. In order to prevent false registration some of the large cities have personal identification laws. The old suffrage laws of the Southern States and the complicated registration laws practically eliminated the negro vote, and even under the recent suffrage amendments to the constitutions, voting by negroes is a difficult task since registrars must determine whether an applicant possesses the required suffrage qualifications, can "read the constitution, or understand it when read to him, or give a reasonable interpretation thereof," or understands "the duties and obligations of citizens under a republican form of government."

**Registry Boards.**—The election process is controlled by official (and usually compensated) boards of registrars, who must be qualified voters in the election districts wherein their duties are to be performed; their duty on the days designated as registration days is to prepare lists of qualified electors to be used as check lists at the polls. If registration officers wrongfully and wilfully refuse to enter the name of a qualified elector on the voting list they are liable in a civil action for damages. The boards are usually bi-partisan and are generally supplemented by watchers from the various parties which have nominated candidates. At election time each party usually has one or more challengers who endeavor to prevent election frauds by challenging those illegally attempting to vote or those whose right to vote is considered doubtful. Generally, any citizen who believes an elector is attempting illegally to cast a ballot has the right to challenge him and to state his objections. In Massachusetts cities and towns, at specified times preceding elections, the registry boards are in session for the purpose of allowing applicants to prove their possession of the required suffrage qualifications, but in Boston the police, under the supervision of a special listing board, make a house-to-house canvass to enroll voters. Under the New York law of 1908 the registry boards in cities of over 1,000,000 inhabitants must very carefully examine the voter, not only as to name, age, birthplace, address, occupation, years of residence in State and at address, and where and

when he last voted, but also if he be married, if he occupy the entire house, or only a floor or room and which one; and they must obtain the name of lessee of the building, etc. Hence, if challenged when voting, a comparison of the voter's answers with the data previously supplied will quickly and quite dependably prove his identity, which can also be more accurately determined by a comparison of signatures, since those who can write must sign the registry book. All lists of registered voters are public records and are open to reasonable inspection by the public.

**The Voting Process.**—The names and residences of voters are recorded in the pollbook in numerical order as they enter the polling places, after which the election official gives the voter a ballot usually corresponding in number with his number in the pollbook, though the courts have decided that, where a State constitution requires that popular elections shall be by secret ballot, any statute requiring the numbering of ballots with figures corresponding with the figures placed opposite the voter's name on the poll list is unconstitutional and void, since it utterly destroys the secrecy of the ballot. The voter then retires to the booths provided so that the ballot may be marked secretly, but should he be unable to read or write or be physically incapacitated he may request assistance from one of the election officials. All members of the election board (but no one else) may witness the preparation of the ballot of such voter, but must not reveal the name of the person for whom the elector has voted. After marking the ballot the voter folds it so that the contents may not be seen and hands it to the designated election officer, who deposits it in the ballot box, which is kept locked, the key being in the custody of the chairman of the board; this completes the process and a clerk records in the pollbook the fact that the elector has duly voted. Should a ballot be mutilated, the elector may obtain a perfect one from the election officers on surrendering the defective one. Legislatures may prescribe official ballots and prohibit the use of any other; they may also provide for printing on the ballots the names of regularly nominated candidates or of independent candidates, provided in so doing they do not violate the voter's constitutional right to vote for the person of his choice. No legislature is empowered to restrict electors in their choice of candidates or to prohibit them from voting for others than those whose names are on the ballots. Nominations entitle nominees to places on the official ballot, printed at public expense but the voter may write or paste on his ballot the names of eligible candidates (whether nominated or not by any convention, caucus or meeting) other than those printed thereon, and this right is generally recognized since blank spaces next to the printed names are left for such writing or pasting. The right of an elector to vote may be challenged if his qualifications appear to be defective or if he be suspected of some fraudulent practice. An oath or affirmation is then administered to the challenged elector under which he swears truthfully to answer all questions respecting his qualifications, but if the elector refuse to be sworn and examined he loses the right to vote. If the answers to these ques-

tions seem to establish the elector's right to vote and the challenge be withdrawn, the elector, again under oath, must declare that he possesses all the legal requirements. He may then vote but the act of voting, after taking the oath, renders him liable to criminal prosecution if his declarations be proven false.

**The Ballot.**—See **BALLOT**.

**Voting Machines.**—See **VOTING MACHINES**.

**Counting the Vote.**—Usually the polls are open from early in the morning until a designated hour at night, after which no more voters are admitted. Immediately after the last ballot has been deposited the counting begins (sometimes publicly, sometimes in a private room), the details being recorded on the official and standard tally sheets with which each polling place has been furnished. The chairman unlocks the box, extracts the ballots, one by one, opens each and announces the candidate for whom the elector has voted. If mutilated or illegally marked by the voter the ballot may be rejected; though ballots should not be rejected because of tearing or of slight irregularities in marking unless such mark or mutilation appear to have been made for corrupt purposes; all rejected ballots are set aside and returned with the valid ballots so that, in case of a contest, the proper judicial authorities may examine them. All valid ballots are recorded by the clerks as announced by the chairman and are then filed in the form required by law. The clerks keep two or more independent tally sheets which are totalled at the end of the counting and the results officially announced. The pollbooks and the tally sheets (properly authenticated by the election officials of the district) are then sealed and turned over to some designated official, such as the county clerk or in larger cities to a special board. The ballots are locked and sealed in the ballot boxes which are then delivered to the proper authorities, in some cities, as New York, to the police who preserve them for a stipulated period so that a recount may be made in case of a contested election. After the tally sheets have reached the election board or other designated official, such as the county clerk, they are reviewed to ensure absolute correctness and the results are officially published. In State elections, county or municipal results are usually dispatched to the secretary of state who reviews them with the aid of a State board of canvassers. In some States the individual voting districts send their returns direct to the secretary of state; in other States these returns are sent to the presiding officers of the two branches of the legislature and are opened and canvassed in their presence. In other States the returning boards consist of certain specially designated officers. It is the duty of the canvassers to issue a certificate of election to the person whom the face of the returns indicates to have been elected. Should a candidate (who may or may not have been present at the count of the ballots) believe he has been defeated by fraud, illegal voting or incorrect counting, he may file a contest notice with the court having jurisdiction, which not only may order a recount but may also enforce its judgment as against the conclusion of the election official. Unless a specific grant of power be made in the State constitution or by the legislature in conformity with constitutional provisions, the duties of county

and State canvassing boards are wholly ministerial; they are not empowered to go behind the returns, to decide upon the legality of the votes cast nor to throw out the votes of a precinct or district in which fraud is alleged.

**Duty to Accept Office.**—Under the common law every citizen, in peace as well as in war, owes his services to the State when required; hence, after having been regularly elected and duly appointed, persons may be compelled to take the oath and qualify themselves as public officers under pain of indictment or any pecuniary penalty; the only defenses are illegal election or appointment, legal disqualification to hold the office or proof that the office is incompatible.

**Contested Elections.**—See **ELECTIONS, CONTESTED**.

**Federal Control of Elections.**—See **ELECTIONS, FEDERAL CONTROL OF**.

**Electoral Frauds and Safeguards Against.**—See that title.

**Minority and Proportional Representation.**—See that title.

**Majorities and Pluralities.**—There is no legal, philological or popular agreement as to the use of the word "majority" in matters of election. In computation it may mean the amount by which the greater number exceeds the lesser, if but two numbers are compared; or the amount by which the greatest number exceeds the total of the lesser numbers; or the amount by which the greatest number exceeds the next to the greatest. For the last case we customarily use the word "plurality" but in England the normal designation is "majority," and candidates have been elected with regard only thereto from time immemorial. The weight of American usage restricts "majority" to excess of the greatest number of votes over the total of the rest, and we say that for a majority a total of one more than half is necessary. This practice dates from colonial times. In Massachusetts, New York, New Jersey, South Carolina and Georgia, a majority seems to have been required; in other colonies as a rule a simple plurality sufficed. New York put the plurality rule into her constitution of 1777 and most of the other States followed her example, but the belief in the virtues of an absolute majority lingered in the New England States till the middle of the following century. Propositions to go back to the absolute majority plan are now very rarely heard, and in the matter of popular elections the subject still has importance only because the Constitution of the United States requires an absolute majority of electoral votes for the choice of President. In conventions the majority rule yet prevails, occasionally entailing hundreds of ballots, and in the Democratic national conventions a two-thirds vote is required to nominate. In primaries and caucuses the plurality plan prevails by almost invariable custom, voters everywhere being unwilling to give the time required for repeated ballots.

Under the Constitution a majority vote in the electoral college may elect a President who did not receive either a majority or a plurality of the popular votes cast, though probably the framers of the Constitution intended that no President should be elected without substantial support in a considerable number of States. Often delegations are divided under the system

of State-wide popular vote. This is possible if a State legislature should decide that the electors of that State be chosen by districts. This system was followed by Maryland up to 1832 and in 1892 the Michigan legislature changed the districts and thus divided the State electoral delegation. But as a rule all electors, save those chosen by legislatures, have been chosen by general ticket since 1836, for which reason the ticket that obtains a plurality of the popular votes elects all the electors of that State. Sometimes, however, when the vote is close, the electors with the highest vote on one ticket may defeat the electors with the lowest vote on another ticket. This happened in California in 1880 when, of the 161,000 votes cast, the difference on the head of the ticket was only 78, with the result that one Republican and five Democratic electors were chosen. In the same State in 1912 two of the Democratic electors overran the lowest two on the Progressive ticket, so that the State sent a divided delegation to the electoral college of 11 Progressives and two Democrats. Often the electors represent a minority of the State votes, and sometimes the majority of the electoral vote may represent a minority of the popular vote. In 1824 Jackson received 50,550 votes more than Adams, but received 40,300 votes less than his three opponents combined. In 1844 Polk received 38,000 votes more than Clay but the combined vote for Clay and Birney put him in a minority of 24,100. In 1848 Taylor had a plurality of 139,000 but a minority of 151,500. In 1856 Buchanan had a plurality of 497,000 but a minority of 377,000. Lincoln received nearly 500,000 more votes than Douglas but nearly 950,000 votes less than all his opponents combined. In 1876 Hayes, though chosen President by one electoral vote, not only had a minus plurality of 251,000 but was in the minority by about 345,000. In 1880 Garfield had a plurality of 7,000 over Hancock but was in the minority by over 310,000. In 1884 Cleveland received about 62,000 votes more than Blaine but was in the minority by about 230,000. In 1888 Cleveland received nearly 100,000 more popular votes than Harrison but the latter was elected even though he was in a minority of 500,000. In 1892, however, Cleveland received a plurality of 380,000 over Harrison but was in a minority of 950,000. In 1912 a striking discrepancy occurred between the electoral and popular votes, Wilson carrying 43 of the 48 States and having a clear majority of 339 in the electoral college, while he had a plurality of 2,150,000 over his nearest opponent, but was in the minority by 2,500,000. Hence, with the exception of Hayes and Harrison, all the Presidents would have been elected by at least a plurality if the election had been directly popular. On the other hand a small popular majority for the electors in one State may swing the election, as was the case in New York in 1884 and 1888; in the former year Cleveland carried the State by 1,047 which gave him the 36 electoral votes of that State and decided the election in his favor; in 1888 these votes were turned over to Harrison by a plurality of about 15,000, thus electing him President. In 1916 was cast the largest vote in the history of American politics. Wilson had a plurality of nearly 570,000 over Hughes but an electoral vote of only 276

against 255 for Hughes, this being the narrowest margin of electoral votes determining an election since 1876. So even was the voting in some of the States that Wilson won New Hampshire by only 56 votes, New Mexico by 2,400, North Dakota by 2,600, California by 3,700, and Nevada by 5,600, whereas Hughes gained the electoral votes of Minnesota by 392 votes, Delaware by 1,273, West Virginia by 2,721, and South Dakota, Maine and Rhode Island by about 5,000 each. In spite of the closeness of the election no split delegations of electors were sent to the electoral college. See UNITED STATES—DISPUTED PRESIDENTIAL ELECTIONS; ELECTORAL COMMISSION.

**Bibliography.**—Ashley, R. L., 'The American Federal State' (New York 1908); Beard, C. A., 'American Government and Politics' (ib. 1914), and 'The Ballot's Burden' (Boston 1909); Bacon, E. M., and Wyman, M., 'Direct Elections and Law-Making by Popular Vote' (ib. 1912); Bryce, James, 'American Commonwealth' (rev. ed., New York 1914); Burch, H. R., 'Conditions Affecting Suffrage in Colonies' (Philadelphia 1902); Bullock, E. D., 'Short Ballot' (New York 1915); Becker, Carl, 'Nominations in Colonial New York' (in *American Historical Review*, Vol. VI, pp. 260-275, Lancaster, Pa., 1901); Brooks, R. C., 'Corruption in American Politics and Life' (New York 1910); Bishop, C. F., 'History of Elections in American Colonies' (ib. 1893); Commons, J. R., 'Proportional Representation' (ib. 1907); Childs, R. S., 'Short Ballot Principles' (Boston 1911); Clarke, J. H., 'The Pith of the Short Ballot' (Cleveland 1912); Cooley, T. M., 'Constitutional Limitations' (7th ed., Boston 1903); Dougherty, J. H., 'The Electoral System of the United States' (New York 1906); Dallinger, F. W., 'Nominations for Elective Offices' (Cambridge, Mass., 1914); Dickey, F. W., 'The Presidential Preference Primary' (in *American Political Science Review*, Vol. IX, pp. 467-487, Baltimore 1915); Fanning, C. E., 'Selected Articles on Direct Primaries' (Minneapolis 1911); Ford, H. J., 'Rise and Growth of American Politics' (New York 1898); Glasson, W. H., 'The Australian Voting System' (Durham, N. C., 1909); Garner, J. W., 'Introduction to Political Science' (New York 1910); Griffith, E. C., 'Rise and Development of the Gerrymander' (Chicago 1907); Hart, A. B., 'Exercise of the Suffrage' (in *Political Science Quarterly*, Vol. VII, pp. 307-329, 1892) and 'Actual Government' (New York 1908); Haworth, P. L., 'The Hayes-Tilden Disputed Presidential Election of 1876' (Cleveland 1906); Haynes, F. E., 'Third Party Movements since the Civil War' (in *The Nation*, Vol. CIII, pp. 511-512, New York 1916); Haynes, H. G., 'The Election of Senators' (New York 1906); Humphrey, J. H., 'Proportional Representation' (London 1911); Jones, C. L., 'Readings on Parties and Elections in the United States' (New York 1912); Laprade, W. T., 'The Nominating Primary' (in *North American Review*, Vol. CC, pp. 235-243, New York 1914); Lowell, A. L., 'Public Opinion and Popular Government' (ib. 1913); Lowrie, S. G., 'Corrupt Practices at Elections' (Madison, Wis., 1911); Luetscher, G. D., 'Early Political Machinery in the United States' (Philadelphia 1903); Ludington, A. C., 'American Ballot Laws, 1888-1910' (Albany 1910);



Mechem, F. R., 'Law of Public Offices and Officers' (Chicago 1890); McCrary, G. W., 'American Law of Elections' (ib. 1897); McKinley, A. E., 'Suffrage Franchise in the Thirteen English Colonies' (Philadelphia 1905); Macauley, Ward, 'Reclaiming the Ballot' (New York 1916); MacMillan, D. C., 'Elective Franchise in the United States' (ib. 1898); Macy, Jesse, 'Party Organization and Machinery' (ib. 1912); Macy, Jesse, and Ganaway, J. W., 'Comparative Free Government' (ib. 1915); Meyer, E. C., 'Nominating Systems' (Madison, Wis., 1902); Merriam, C. E., 'History of American Political Theories' (New York 1910) and 'Primary Elections' (Chicago 1909); Michael, W. H., 'Elections' (in 'Cyclopedia of Law and Procedure,' Vol. XV, pp. 268-465, New York 1905); and also the articles 'Vote' (in id., Vol. XL, pp. 224-228, New York 1912) and 'Ballot' (in 'Corpus Juris,' Vol. VI, pp. 1173-75, ib. 1916); Ostrogorski, M., 'Democracy and the Party System in the United States' (New York 1910); Potts, C. S., 'The Convention System and the Presidential Primary' (in *American Review of Reviews*, Vol. XLV, No. 5, pp. 561-566, New York 1912); Rhodes, J. F., 'History of the United States,' Vol. VII (ib. 1906); Ray, P. O., 'Introduction to Political Parties and Practical Politics' (ib. 1913); Reinsch, P. S., 'American Legislatures and Legislative Methods' (ib. 1907); Shaw, A., 'National Lesson from Adams County' (in *Review of Reviews*, Vol. XLIII, pp. 171-180, New York 1911); Shepard, E. F., 'Compulsory Voting' (ib. 1891); Schaffner, M. A., 'Corrupt Practices at Elections' (Madison, Wis., 1906) and 'The Recall' (ib. 1907); Stanwood, Edward, 'History of the Presidency' (Boston 1912); Sloane, W. M., 'Party Government in the United States' (New York 1914); Taft, G. S., 'Senate Election Cases' (Washington, D. C., 1903); Throop, M. H., 'Law Relating to Public Officers' (Chicago 1892); Tyson, R., 'Various Voting Systems' (in *The Arena*, Vol. XXXIX, pp. 59-64, 1908); Woodburn, J. A., 'Political Parties and Party Problems' (New York 1914); West, V. J., 'Nominations and Elections' (in *National Municipal Review*, Vol. III, pp. 577-581, Philadelphia 1914); Wilcox, D. F., 'Government by all the People' (ib. 1912); Wigmore, J. H., 'The Australian Ballot System' (Boston 1889); Woodruff, C. R., 'Election Reforms' (in *National Municipal Review*, Vol. V, pp. 611-619, Philadelphia 1916); 'Recent Experiments with the Primary' (in *World's Work*, Vol. XXIII, November 1916).

IRVING E. RINES,

*Editor of 'History of the United States.'*

**ELECTIONS, Contested.** Under the Constitution, when the electoral college fails to cast a majority vote, the election of President was referred to the House and of Vice-President to the Senate. The former decided the election of Jefferson in 1801 and of J. Q. Adams in 1829, and the latter elected R. M. Johnson Vice-President in 1837. But in 1876 a dispute arose over the validity of the election of rival groups of electors in four States (see ELECTORAL COMMISSION) and in 1887 Congress enacted a law providing that each State under its own laws should designate a tribunal to determine the legality of its elec-

toral votes; but should no such tribunal have been appointed in case of double returns, the vote of the State is lost unless the two houses agree as to which electoral votes from the State are the legal votes. Under Art. I, Sec. 5, § 1 of the Constitution, each branch of Congress is the judge of the election, returns and qualifications of its own members. Although the law may be disregarded, the House usually conducts its investigations of contested elections under sections 105 to 130 of the "Revised Statutes." If an election is to be contested, notice must be given within 30 days after the result of the election has been determined; the same period is allowed for an answer; and the testimony must be taken within 90 days. In the House the task of investigating these contests is assigned to three committees, but in the Senate this work is performed by the committee on elections. The investigating committee is always controlled by the party which has a majority in that branch of Congress and its report is seldom rejected. In most of the States each branch of the legislature judges the elections and qualifications of its own members, and this power is granted also to the councils of many cities. As these bodies are supreme within their respective spheres of action, courts are without jurisdiction to hear and determine contested elections of their members. In half the States, the legislature is empowered to decide gubernatorial contests and contests over one or more of the other State offices, but in California, Delaware and Pennsylvania these contests are tried by a joint committee of both houses. In some States all elections are virtually decided by the legislature sitting as the supreme canvassing board. If a specific mode of contesting elections has been provided by statute, that method alone can be employed. In the absence of any statutory proceeding the only common-law remedy is quo warranto proceedings, under which the court demands proof of the authority by which a person exercises the functions of an office and ousts him if he cannot show proper and legal authority. Strictly speaking a quo warranto proceeding is not a contest between two persons for the same office but merely determines if the person holding the office be or be not a usurper. If the incumbent be proved a usurper, the judgment is that he be ousted, whereupon the proper officials will execute the supposed will of the people by placing the candidate actually elected in possession of the vacated office. Consult Michael, W. H., 'Elections' (in 'Cyclopedia of Law and Procedure,' Vol. XV, pp. 268-465, New York 1905); Mechem, F. R., 'Law of Public Offices and Officers' (Chicago 1890); McCrary, G. W., 'American Law of Elections' (Chicago 1897); Rammelkamp, C. H., 'Contested Congressional Elections' (in *Political Science Quarterly*, Vol. XX, pp. 421-442, Boston 1905); Reinsch, P. S., 'American Legislatures and Legislative Methods' (New York 1907); Rowell, C. H., 'Historical and Legal Digest of Contested Election Cases in the House of Representatives, 1789-1901' (Washington 1901); Taft, G. S., 'Senate Election Cases' (Washington 1903); 'Compilation of Senate Election Cases, 1789-1913' ('Senate Document' 1036, 62d Congress, 3d session, 1913); and authorities cited in article ELECTIONS.

**ELECTIONS, Federal Control of.** Under the Constitution the Federal government possesses a large measure of control over elections at which senators and representatives are chosen. Each State legislature possesses the power to prescribe the times, places and manner of holding Congressional elections but Congress is authorized to make entirely new regulations or to add to, modify or alter such regulations, save those relating to the choosing of senators (Art. I, Sec. IV, ¶ 1). In 1842 Congress provided that members of the House should be chosen by districts and this procedure is still in vogue; an act passed in 1866 prescribed the manner of choosing senators by the State legislatures. On 31 May 1870 Congress enacted a law providing that all persons otherwise qualified should be granted the right to vote at all elections, irrespective of race, color or previous condition of servitude, this act being supplemented by another (28 Feb. 1871) relating particularly to the election of representatives. This act stipulated that voting should be by ballot and also provided for the appointment by circuit judges on application of election inspectors in cities, the main object being to break up the prevailing corrupt practices. Federal courts subsequently declared unconstitutional some parts of this law and in 1894 the sections providing for Federal supervision were repealed. On 2 Feb. 1872 Congress definitely established the Tuesday following the first Monday in November (starting in 1876) as the date for Congressional elections but some exceptions to this rule were allowed under the amending act of 3 March 1875. Since that time (apart from the direct election of senators by constitutional amendment) the Federal government has concerned itself chiefly with legislation pertaining to party activities, and passing acts relating to corporation contributions to campaign funds, publicity of campaign funds, corrupt practices acts, etc. See **CORRUPT PRACTICES ACTS; ELECTORS; ELECTIONS, CONTESTED.**

**ELECTIVE AFFINITIES, The.** Goethe's 'Wahlverwandtschaften' (Elective Affinities), first intended for insertion among the numerous short stories in the second part of 'Wilhelm Meister,' grew beyond the limits of availability for such use, and was published independently in 1809. Its composition is in the leisurely and somewhat oracular style which makes many of the episodes in 'Wilhelm Meister' seem more like the deliverance of a seer than a mirror of actual life; but here as elsewhere Goethe develops a significant *motif* in terms of human experience, and the symbolical title befits the manner in which his narrative of what happens to a particular group of persons invites the mind to ponder the inscrutable laws governing human behavior in general. The analogy between chemical reactions and the solution of personal bonds in the moral sphere has for us less of mystical fatality than it had for Goethe's romantic contemporaries; for us, however, as for them the issue raised is momentous, and the treatment—in many respects romantic—leads us to examine the sanctions of the first of all social institutions.

The story deals primarily with a wedded couple into whose domestic circle two other persons are introduced; but of these four, the young girl Otilie is the one upon whom our

attention is focused. The others, even the wife, persons of experience in the world, may be left to accommodate themselves to changed conditions; with Otilie we profoundly sympathize; for she, a being of celestial purity and devotedness, becomes unwittingly involved in the toils of earthly life to which she is a stranger, and must by renunciation and death atone for an involuntary fault. Conceived in dramatic terms, the theme might be said to be the conflict of individual right with social convention. But Goethe's concern is not with any moral question or any dramatic demonstration; it is with the martyrdom of a hapless maiden, considered in its psychological aspect. The work, too restricted in scope to be called a novel, too diffuse to be a *Novelle*, is a study of singular penetration and completeness in the inner life of a beautiful soul. Translated by J. A. Froude and R. D. Boylan, London 1854. Consult 'The German Classics' (New York 1913, Vol. II).

WILLIAM G. HOWARD.

**ELECTIVE AFFINITY**, a term formerly used in chemistry, in connection with the supposed fact that when a given chemical substance is mixed with two or more others with which it is capable of combining, it will exhibit a preferential affinity for one of them, and combine with that to the exclusion of the others. This view of chemical action is now known to be incorrect. See **EQUILIBRIUM, CHEMICAL.**

**ELECTIVE COURSES and ELECTIVE STUDIES**, as applied to colleges and universities in particular, and to all schools in general, may be defined broadly as that principle in education which permits the student to choose his own subjects of study during the time of attendance at school.

The 'elective' or 'optional' feature of educational systems is not new: it was in existence in many of the leading schools of the Mediaeval Ages, and even earlier. In the United States the principle first appeared in the curriculum of the University of Virginia in 1819. Harvard introduced it in 1826, and from that time on it received more or less recognition throughout the country. However, so few availed themselves of the privilege of making the elective choice that more and more it came to be required that students should pursue certain studies in order to obtain the degree of bachelor of arts; and such restriction eventually led to the exclusion of all studies that did not contribute to the obtaining of the desired degree. Gradually the secondary schools adopted compulsory courses of study preparatory for colleges, and crowded out many of the studies that might fit the student for business life without going the college road. The special commercial, scientific and art schools came into existence to meet the wants and needs of a large number of students. In the meantime, the addition of many new branches of study so enlarged the educational resources of the larger institutions that a selection of studies became a necessity, and it seemed wise to allow the student to elect a course which should definitely aid him in preparing for a chosen occupation after leaving college. The difficulty experienced in the extension of the elective course has been found in the fact that the choice made by the untutored mind of the average

student was likely to be ill-balanced. This defect is overcome where able instructors, those who understand human nature and its needs, guide the immature student; or, to use the modern term, where there are wise "advisers." Present practice shows a wide variation from administrations where the entire course is rigidly prescribed to those where every study is elective. In most colleges a part of the course is prescribed and the remainder elective. The tendency, however, is toward a system in which, while there are prescribed courses, the student is encouraged or perhaps required to concentrate his energies on some special line of study, and to round out his course with studies wholly elective, with the advice of the professors. In order to ascertain what colleges and universities sanction elective courses it is necessary to obtain the latest changes direct from the college authorities. As an illustration of the policy of the educational institutions in the United States the following summary gathered from 29 State universities and 55 other colleges and universities is of interest. English is required in 78 of these institutions; it is elective in 6. One (at least) foreign language is required in 68; elective in 14. Mathematics is required in 61; elective in 23. Natural science is required in 52; elective in 32. History is required in 41; elective in 43. Physical education is required in 38; elective in 46. Philosophy is required in 32; elective in 52. Psychology is required in 21; elective in 63.

Consult Adams, 'Evolution of Educational Theory' (1912); Baker, 'American Problems' (1907); Burns, 'Elective System of Studies in Colleges' (*Catholic World*, Vol. LXXI, 366); Eliot, 'Educational Reform' (1905); and 'Essays and Addresses' (1909); Foster, 'Administration of the College Curriculum' (1911); Hanus, 'Problem of Electives' (*Popular Science Monthly*, Vol. LVIII, 58); Phillips, 'Electives in American Education' (*Pedagogical Seminary*, Vol. VIII, 206); Shaler, Thurber and others. 'Elective Studies in Secondary Schools' (*Educational Review*, Vol. XV, 417); Thurber, 'Some Problems of the Elective System' (*School Review*, Vol. IX, 79).

**ELECTIVE MONARCHY.** See **MONARCHY**.

**ELECTORAL COLLEGE.** See **ELECTORS**.

**ELECTORAL COMMISSION, 1877.** The electoral vote in the presidential election of 1876 showed 184 undisputed votes for Tilden; 163 for Hayes; four States with 23 votes — South Carolina, 7; Florida, 4; Louisiana, 8; Oregon, 3 — sent in conflicting returns. If the Republicans won all the contests, Hayes was elected by one vote. Of these States, the first three returned popular majorities for Tilden electors; but the "carpet-bag" governments in each had constituted "returning boards," whose function was to throw out enough Democratic votes, on the ground of intimidation of negro voters, to leave a Republican majority. Neither the reality of the intimidation, nor the arbitrariness of the assumption that but for it the negroes would all have voted and all voted Republican, is now disputed by either party. Oregon chose Hayes electors; but as the returning boards would give the Republicans the other three States, and therewith the election if upheld, the

Democrats ousted a Hayes elector on a technicality and replaced him by a Tilden one, as a basis of compromise or a menace. Obviously, the Republicans could not compromise anything and win; and as they held the administration and the army, they could defy threats. The Senate was Republican, the House Democratic; there was therefore a deadlock on the admission of returns, as the 22d Joint Rule, throwing out disputed States, had been repealed by the Senate 20 January for this very emergency. Finally, as an alternative to a most dangerous anarchy, both sides agreed on a joint commission to pass on all the contests; the Democrats being confident that it could establish no guiding principle whatever, of going behind the returns or not, accepting or rejecting State certificates as conclusive, which would not give them at least one of the disputed States. They underestimated the intellectual resources of their opponents. The act creating the commission was approved 29 Jan. 1877; its decisions could only be reversed by concurrent action of both Houses. The body was to be composed of five members of each House and five associate justices of the Supreme Court; the latter as indicated were two Republicans and two Democrats, and were to select a fifth. The Senate appointed three Republicans, — G. F. Edmunds of Vermont, O. P. Morton of Indiana and F. T. Frelinghuysen of New Jersey; and two Democrats, — T. F. Bayard of Delaware and A. G. Thurman of Ohio, the latter taken sick and replaced by Francis Kernan of New York. The House appointed three Democrats, — H. B. Payne of Ohio, Eppa Hunton of Virginia and J. G. Abbott of Massachusetts; and two Republicans, — J. A. Garfield of Ohio and G. F. Hoar of Massachusetts. Obviously, therefore, the odd justice would have the deciding voice. The Republican judges were William Strong and Samuel F. Miller; the Democratic, Nathan Clifford and Stephen J. Field; they chose Joseph P. Bradley as the fifth. The counsel were — Democratic, Charles O'Connor of New York, Jeremiah S. Black of Pennsylvania, Lyman Trumbull of Illinois, R. T. Merrick of the District of Columbia, Ashbel Green of New Jersey, Matthew H. Carpenter of Wisconsin, George Hoadley of Ohio, W. C. Whitney of New York; Republicans, W. M. Evarts and E. W. Stoughton of New York, Stanley Matthews and Samuel Shellabarger of Ohio. Other lawyers appeared on special points. The States were taken up in alphabetical order, — Florida, Louisiana, Oregon, South Carolina, — and the vote upon each was eight to seven for the Republicans, on every contested point, Mr. Justice Bradley sustaining all the contentions of that side and the Republican candidate was declared elected. The broad decision was, that Congress cannot, as it had done repeatedly before, go behind the returns and take evidence as to the manner in which State majorities for electors have been obtained. On other points the decisions varied with the cases. In particular, the Democrats contended that the question as to the eligibility of an elector who is also a government official — a combination forbidden by the Constitution — was decided in two different ways within two days, on the Florida and Louisiana cases, in both to the profit of the Republicans; and Judge Bradley published a defense of his action. The court adjourned

*sine die* on 2 March. The peaceful acceptance of the decision was much helped by the Democratic speaker, Randall of Pennsylvania, who firmly checked all Democratic attempts to "filibuster." The proceedings of the Commission may be found in the 'Congressional Record' (Vol. V, Part IV, 1877). Consult Haworth, 'The Hayes-Tilden Disputed Presidential Election of 1876' (Cleveland 1906).

**ELECTORAL FRAUDS AND SAFEGUARDS AGAINST.** The most common electoral fraud is bribery (q.v.), consisting of the gift of money or the promise of some reward either to vote "right" or to remain away from the polls. Employers of labor have been accused of attempting to influence the votes of their employees by threats of loss of work, reduced wages, etc.; physical violence has been used many times; and sometimes the threatened loss of social caste has operated to sway the voter. Priests have no right, either in or out of the pulpit, to influence electors to vote a particular way, by threats of excommunication, refusal of the sacrament and the like, and if they do so, it is, according to court decisions, an undue influence which may vitiate the election. The insertion of fictitious names on the roll, the registration of non-residents or non-citizens, etc., is almost impossible under present methods of registration. One source of election evil is found in faulty methods of identifying voters. The fraud that results takes the form of "impersonation" (voting on another man's name), or "repeating" (voting more than once). Sometimes forged naturalization papers are issued to prevent the discovery of fraudulent voting. Floaters are employed in many cases, especially in the crowded districts where election officials do not know the individual voters. Where a party has too many votes in one precinct and too few in another, colonization is sometimes practised (see BLOCKS OF FIVE; and in this connection see also GERRYMANDER); groups of actual voters may be transferred from a "safe" precinct to a "doubtful" one and still fulfil the letter of the law if only a brief residence be required. To lessen the likelihood of these crimes, some States require every voter to establish anew each year his right to vote; others allow a name once on the lists to stay there till death or removal causes it to be dropped. With our dread of red tape and formalities, we hesitate to adopt the ultimate remedy prevailing in France, where every man, as he steps up to the ballot-box, must produce his "electoral card" on which are inscribed his full name, profession and residence. This card is issued by the mayor of the town where the voter lives, after the latter has established his identity and majority by the production of a properly attested "act of birth." Each electoral card is numbered, and when it is presented at the polls, the judge of elections takes it, and calls off the number and name, while two other judges, with the official poll-list before them, repeat aloud the number and name and check off on the register. Then, and not till then, the first judge accepts the ballot from the voter and drops it into the box; and before handing back the card, he tears off a corner of it, which renders it useless for further voting that day. These bits of card are strung on a wire and are counted, at the close of the polls, to see if

they tally with the number of ballots in the box. Various methods are employed to destroy the efficacy of a ballot after it has been marked by the voter. False counting of ballots has been an easy and common way to vitiate election results. Knavish counters may nullify ballots by adding marks or altering them; ballots may be rejected on trivial grounds; and sometimes ballot boxes may be stuffed before the polls open. Defective ballots may be printed by omitting or shifting the position of candidates' names.

Election frauds developed early, and an especial abuse was the temporary conveyancing of lands, so as to enable the grantees to vote for a certain candidate. The election laws of Rhode Island, New Jersey and Virginia for the decade 1760-70 declared penalties for these frauds. The illicit use of money in elections began almost at the beginning of political history in America. Rhode Island, for instance, found it necessary to pass a general act against bribery and corruption in 1737, and 10 years later replaced it with one even more stringent. Judging by its provisions the evil must have been persistent in that colony. On 14 Oct. 1643 the General Court of Massachusetts ordered "that if any freeman shall put in more than one paper or beane for the choyce of any officer, he shall forfeit 10s 1d for every offence; and any man that is not free, putting in any vote, shall forfeit the like somme of 10s 1d." The other New England colonies found no such laws necessary, but all the others had them save New York and Maryland. In England the purchase of votes was for centuries as natural a thing as the sale of boroughs, and no serious attempt to prevent it was made until 1854, when the Corrupt Practices Prevention Act defined bribery, forbade certain petty expenditures and required publicity of election expenses of a certain character. Despite this and other legislation, the evil did not greatly diminish and in 1883 a more drastic measure was adopted, which has served as a model for legislation elsewhere. In England and Scotland if the number of electors does not exceed 2,000, the Parliamentary candidate's maximum allowance for expenses is £380, with an additional £30 for every 1,000 electors above 2,000. In Ireland (which contains many small borough electorates), where the number does not exceed 500, £200; exceeds 500 but does not exceed 1,000, £250; exceeds 1,000 but does not exceed 1,500, £275. After this number has been reached, the rate is the same as in England. In the counties where the number of electors does not exceed 2,000 (in England and Scotland) the maximum allowance is £650, with an additional £60 for every complete 1,000 above 2,000. In Ireland, for the same number of electors, the maximum allowance is £500 and £540 respectively, with an additional £40 for every complete 1,000 above 2,000. These items do not include returning officers' fees or the personal expenses of candidates. In the United States all the States have enacted laws penalizing those who commit offenses against the suffrage. Most of the States have provided means to control the use of money in elections, some limiting the amount that may be expended by each candidate and compelling a sworn statement of receipts and expenditures; some defining the objects for which money may be spent; some re-

quiring campaign financial committees to render a detailed statement of sources of receipts and objects of expenditures; and many prohibiting absolutely the gift of money or property to any political party, committee or organization by any corporation or joint-stock company. The more recent enactment of direct primary, initiative, referendum and recall measures (qq.v.) has also done much to rid politics of corrupt influence. Moreover, if at all possible, the courts prefer to give effect to elections, particularly if they give evidence of having been conducted fairly and honestly; and even the most glaring irregularities not actually constituting fraud have been held not to invalidate an election. See CORRUPT PRACTICES ACTS; BALLOT, etc. Consult Brooks, R. C., 'Corruption in American Politics and Life' (New York 1910); Ford, H. J., 'Rise and Growth of American Politics' (ib. 1898); Griffith, E. C., 'Rise and Development of the Gerrymander' (Chicago 1907); Lowrie, S. G., 'Corrupt Practices at Elections' (Madison, Wis., 1911); Shaw, A., 'National Lesson from Adams County' (in *Review of Reviews*, Vol. XLIII, pp. 171-180, New York 1911); Schaffner, M. A., 'Corrupt Practices at Elections' (Madison, Wis., 1906); and authorities cited under article CORRUPT PRACTICES ACTS.

#### ELECTORAL QUALIFICATIONS; TERMS OF AND QUALIFICATIONS FOR OFFICE.—

The theory that suffrage is a natural, inherent right, belonging to every man, is now generally discredited. Political rights are not essential to citizenship, and in a dissenting opinion in the case of *Amy vs. Smith* (1 Litt. [Ky.], 326, 333, 342), one judge said:

"A State may deny all her political rights to an individual and yet he may be a citizen. The rights of office and suffrage are political purely, and are denied by some or all the States to part of their population, who are still citizens. A citizen, then, is one who owes to government allegiance, service, and money by way of taxation, and to whom the government, in turn, grants and guarantees liberty of person and of conscience, the right of acquiring and possessing property, of marriage and social relations, of suit and defence, and security in person, estate and reputation. These, with some others which might be enumerated, being guaranteed and secured by government, constitute a citizen."

Again the Supreme Court has held that—

"The fact that one is a subject or citizen determines nothing as to his rights as such. They vary in different localities and according to circumstances. Citizenship has no necessary connection with the franchise of voting, eligibility to office, or indeed with any other rights, civil or political. Women, minors, and persons non compos are citizens and not the less so on account of their disabilities." (*United States vs. Rhodes*, 1866, Abb. U. S. 28, Fed. Cas. No. 16,151; see also *Minor vs. Happersett*, 1874, 21 Wall. 162).

That suffrage cannot be termed a "right" is obvious since no community can ever enfranchise all its citizens, two-fifths of whom are excluded from participation in governmental affairs because legally they are infants and, as such, unfitted to cope with government problems to the benefit of the State. Hence there is no necessary relation between citizenship and the right to vote. Minors and women (the latter save in those States having woman suffrage) do not usually possess the right to vote, although they are citizens; and on the other hand, some States and many municipalities permit persons to vote who have no claim to citizenship merely because they are residents and possess the other qualifications. Such a thing as the "popular vote" does not exist since millions of

women have not yet been vested with full suffrage; in many States bigamists, bribers, idiots, insane persons, etc., cannot vote; certain classes of foreigners may never exercise the elective franchise; paupers, as dependents, do not participate in shaping the government on which they are a burden and to which they contribute nothing; and the criminal, by his very acts, has exhibited his total incapacity to understand his citizenship privileges. Nevertheless, and in spite of the above restrictions, the suffrage is gradually widening and broadening, partly due to the progress of woman suffrage.

**The Right to Vote and the Power to Confer It.**—As previously stated, the elective franchise is a privilege rather than a natural right; its extension to any excluded class is a question of political expediency; it may be taken away by the power which conferred it and if this be done no vested right is violated nor bill of attainder passed. Subject to the restrictions of the national Constitution as to race, color and previous condition of servitude, each State possesses the supreme and exclusive power to regulate the right of suffrage and to define the qualifications of its voters, however unwise, unjust or even tyrannical its regulations may be or seem to be in this regard. Hence the clauses in some State constitutions requiring of voters the ability to read, understand or interpret reasonably any section of such constitutions are not in contravention of the United States Constitution. Once granted by a State constitution, the right to vote cannot be abridged by the legislature; if they be fixed by the constitution that body cannot add to the qualifications of voters nor create other classes of voters, nor dispense with any of the constitutional qualifications nor enact provisions imposing upon a particular class of citizens conditions and requirements not imposed upon all others. On the other hand, the legislature may enact laws to regulate the exercise of the elective franchise, if those laws do not deny the right of the franchise itself. Under the national Constitution Congress cannot prescribe the qualifications of electors in the States, but Congress may penalize a criminal by forfeiting his United States citizenship, and if under the State constitution only United States citizens are allowed to vote, Congress may thus deprive a person of the opportunity to enjoy a right which belongs to him as a citizen of the State, even the right of voting, but cannot deprive him of the right itself. The Constitution does not confer the right of suffrage upon anyone individually nor upon any class of persons—the United States has no voters of its own creation in the States. It is true that the Fifteenth Amendment is usually interpreted as giving the negro the right to vote, but it merely exempts from discrimination in the exercise of the elective franchise and no negro possesses the right to vote unless he conform to all the qualifications and restrictions imposed by the State constitutions upon white voters. But Congress may punish any State official who refuses to perform the duties necessary to qualify all colored citizens. Thus the right to vote in the States is conferred by the States but the right of exemption from the prohibited discrimination comes from the national government.

The Constitution says that Congressmen

shall be chosen by the people of the several States and that "the electors in each State shall have the qualifications requisite for electors of the most numerous branch of the State legislature" (Art. 1, § 2, ¶ 1). The States do not define who shall vote for Congressmen but merely prescribe the qualifications of those who vote for the popular branch of their own legislatures and the Constitution says that the same persons vote for Congressmen. Hence Congressional electors do not owe their right to vote to the State law in any sense which makes the exercise of the right exclusively dependent on the law of the State. Since the right to vote is not natural, the State, unless expressly prohibited by its constitution, may confer the right only on those who pay taxes for the support of the government; and even though the constitution fix the qualifications of voters at general elections, yet the legislature, in granting municipal charters and providing for special local elections, may make the payment of taxes a condition precedent to the right to vote at such elections. If United States citizenship be a requisite qualification of an elector, a forfeiture of that citizenship will disqualify him, provided a regular legal trial and conviction be shown. Many of the State constitutions provide that persons convicted of infamous crimes or crimes of a high degree lose the privilege of voting and it has been held also that a conviction of crime of a disqualifying nature in a Federal court has the effect to exclude the person convicted from office and suffrage the same as if he had been convicted in a State court. A general absolute pardon of the executive restores the convicted person to the full enjoyment of his civil rights, including the right to vote, and a Presidential pardon likewise restores the right to those convicted in Federal courts, but while a Presidential pardon restores the criminal to the rights and privileges of a citizen of the United States, it does not, without the assent of the State, restore him to the exercise of that right if the sovereign power of the State has excluded him from the right of suffrage. Unless pardoned by the executive, ex-convicts continue to be disfranchised. In this connection the existence of a double citizenship in the United States should be mentioned. One authority says:

"There is a clear distinction between national citizenship and State citizenship. A person who is a citizen of the United States and a resident of a particular State is necessarily a citizen of that State. On the other hand a person may be a citizen of the United States and not a citizen of any particular State. This is the condition of citizens residing in the District of Columbia, and in the territories of the United States, or who have taken up a residence abroad. So a person may be a citizen of a particular State and not a citizen of the United States, as an alien who has declared his intention to become a citizen and who is by local law entitled to vote in the State of his residence and there to exercise all other local functions of local citizenship, such as holding office, the right to poor relief, etc., but who is not a citizen of the United States. Nothing which a State can do will invest a foreigner with the rights and privileges of a citizen of the United States." (*Corpus Juris*, Vol. XI, p. 777).

**Colonial Electoral Qualifications.**—The principal qualification required of the early colonial electors was that they should be "freemen," a term of various interpretations even in the colonies themselves, but held generally to mean persons of recognized responsibility. In Virginia and North Carolina, Indians and negroes were not allowed to vote. In South

Carolina and Georgia the privilege was restricted to white men, but the law was not rigidly enforced, for free negroes were recorded as voting in South Carolina in 1701. In Pennsylvania only natural-born subjects of England could vote; in Massachusetts, after 1664, only Englishmen could vote. In South Carolina, however, the French Huguenots had equal franchise with the English "freemen." In general, the voter was required to be of good moral character and obedient to the laws; immoral behavior might result either in temporary or permanent disfranchisement. In Plymouth voters were to be "orthodox in the fundamentals of religion." Massachusetts in 1631 demanded also, "to the end that the body of the freemen may be preserved of honest and good men," that "henceforth no man shall be admitted to the freedom of the commonwealth but such as are members of some of the churches within the limits of this jurisdiction." This provision, however, lasted only until 1664 or 1665. Massachusetts excluded Quakers, but they were permitted to vote in Rhode Island and Connecticut, which colonies did not specify church membership; while in the other colonies their reluctance to take oaths usually operated to debar them from the franchise. In most of the colonies Roman Catholics were not allowed to vote, New Haven and, for a time, Maryland being notable exceptions. New York excluded Catholics in 1701 and Jews in 1737. Virginia was the only colony specifically debarring women from the franchise, though they were effectually excluded in South Carolina, Georgia and Delaware; but the others incidentally excluded them by according the vote only to "freemen," or by confining the suffrage to males of at least 21 years of age. However, the laws often read "freeholders," rather than "freemen," and it is impossible to tell how far under this the women voted, though at least a few voted in New Jersey. In Virginia a property qualification was required: a voter must be a "housekeeper," either as owner or tenant. Massachusetts, Delaware and Maryland required an estate of at least \$200; after 1699 New York required that voters for members of the lower branch of the legislature be "freeholders" of an estate valued at not less than £40, but in Albany and New York city all "freemen" were allowed to vote. Rhode Island stipulated that voters must possess "competent estates," which, later, were defined as the possession of \$500, or a rental list of at least \$10 (afterward \$50, and still later, \$100) per annum. Pennsylvania, New Jersey, Delaware, Maryland, North Carolina, South Carolina and Georgia required the possession of 50 acres of land, of which a certain (varying) portion should be under cultivation. Virginia required the possession of 100 acres of land if untenanted, and 25 acres if a residence not less than 12 feet square were built upon the land and occupied. The same size of house on a small lot in a town fulfilled the colony's requirement in this respect. At Wilmington, only those could vote who had occupied brick houses at least 16 feet wide and 20 feet long, and for at least three months preceding the election. The residence qualification in other colonies varied from six months in Georgia to two years in Pennsylvania and Delaware. See also UNITED STATES — SUFFRAGE IN THE

**Broadening of the Suffrage.**—When the Constitution was framed in 1787 suffrage qualifications were so divergent in the various States that no attempt was made to impose restrictions and the States were allowed to modify their electoral qualifications as they deemed wise, the only restriction being that contained in Article I, § 2, ¶ 1 which provides that Congressmen shall be elected by people in the various States "who have the qualifications requisite for electors of the most numerous branch of the State legislature." At that time this distinction was of great importance since all the States required the payment of taxes or ownership of real or personal property varying in value from \$33 to \$200. Moreover, North Carolina distinguished between electors for members of her legislature; to vote for a member of the lower house the elector need only to have paid taxes, but to vote for a member of the senate he must own a freehold of 50 acres. New York required that all voters for members of the assembly own a freehold valued at £20 or pay rent of 40s. and that taxes must have been paid to the State during the previous year; while the person who voted for senator must be possessed of an unencumbered freehold valued at not less than £100. Gradually these requirements were eliminated, the property test being abolished by Maryland in 1801 and 1809, New York and Massachusetts in 1821, Tennessee in 1834, New Jersey in 1844, Connecticut in 1845, Virginia in 1850, South Carolina in 1865, North Carolina in 1854 and 1868; and the tax-paying test being abolished by New York in 1826, Louisiana in 1845, Ohio in 1851 and Virginia and Mississippi in 1882. Nevertheless, many States continued to insist upon the poll tax and Rhode Island still has a law that prohibits a person who has not paid during the previous year a tax upon his property in the State valued at \$134 at least from voting for city councilmen or upon any measure of municipal finance. Some of the other States now have tax or property tests as will appear in the subjoined table. The next great extension of the suffrage was an outcome of the Civil War, when during the Reconstruction period (see UNITED STATES—RECONSTRUCTION IN THE) the Fourteenth and Fifteenth Amendments to the Constitution were adopted, forbidding the States to discriminate against the negro. Finally women have won voting privileges on an equality with men—in Wyoming (1869), Colorado (1893), Utah (1896), Idaho (1896), Washington (1910), California (1911), Kansas (1912), Arizona (1912), Oregon (1912), Alaska (1913), Montana (1914), Nevada (1914), New York (1917, effective 1918). In other States they possess a restricted suffrage, for details of which see WOMAN SUFFRAGE. See also BALLOT; VOTE, VOTERS, VOTING.

**Modern Electoral Qualifications.**—Most of the States have uniform laws for electors of every officer to be elected in the State, though this statement must be qualified as to those States which permit women to vote in the election of school boards or committees, or which allow women who are taxpayers to vote upon financial measures. Unlike some European countries, such as Germany, the vote of the lodging-house dweller, the loafer, etc., in

the United States carries as much weight in the election as the vote of the wealthiest or most distinguished citizen. Most of the States require that their voters be full-fledged United States citizens. As a rule the State constitutions require that a voter be a male, at least 21 years of age, who is a citizen of the United States, either native or naturalized, and can read or write English or both. The "male" provision, of course, is inoperative in those States wherein women enjoy the suffrage. Some States, particularly those that are anxious to obtain immigrants as agricultural laborers, extend the privilege of voting to an alien who has declared his intention of becoming a citizen and has resided in the State a certain period of time before election—usually six months to a year. Such a voter is not bound by an oath of allegiance to the United States nor has he foresworn allegiance to his native land; hence a situation might arise under which this voter would help elect the officers of the United States government and the next day the United States might become involved in a dispute with the government of his native country over some question respecting his citizenship. Courts have ruled that if a father become a naturalized citizen of the United States before his son shall have attained his majority, the latter, though alien-born, ipso facto becomes a citizen and need not undergo the formality of naturalization if dwelling within the United States ("Revised Statutes," Title XXX, § 2172); but the son of an alien cannot be vested with citizenship by implication merely because the father declared his intention of becoming a citizen prior to the time the son attained his majority. Basing his statements on court decisions, one authority says:

"While it has been held that citizenship will not be presumed merely from the fact of having owned real estate, having voted, or having held an elective office, it seems that having participated in elections and having held elective offices are facts strongly tending to establish at least a prima facie case of citizenship; and it has been held that, where the State confers the right of State citizenship on aliens who have declared their intentions to become citizens of the United States, the act of voting is conclusive proof of an acceptance of such State citizenship by them." (*Corpus Juris*, Vol. XI, p. 787).

Some States enfranchise men of Indian descent, native of the United States, while others grant the privilege to Indians who have been declared citizens of the United States by act of Congress and to civilized Indians, not members of any tribe. As a rule, idiots, insane persons and felons are not allowed to vote and sometimes vagrants, paupers, persons convicted of treason, bribers, embezzlers, bigamists, Chinese, etc., are excluded. Some constitutions state that United States soldiers and seamen gain no voting residence by being stationed in the State, while the residents of the District of Columbia, when it became the seat of the general government, lost the right to vote therein for national officers or on matters of national concern.

**Educational and Other Tests.**—The educational, property, tax, and good character tests, grandfather clauses, etc., have operated to exclude many thousands of voters—particularly the negro voters of the South. Connecticut in 1854 and Massachusetts in 1856 led the other States in requiring of voters the ability to read the constitution and (in Massachu-

setts) to write their own names. To some extent the national naturalization laws have offset the effects of these tests since an applicant for citizenship must sign the application in his own handwriting and when taking out his final papers must be able to speak the English language. (See ALIENS; CITIZENSHIP IN THE UNITED STATES; NATURALIZATION). The exclusion of the negro in the South was undertaken to assure permanence of white rule, since the negro, during the Reconstruction period, had displayed a total unfitness to govern. Constitutional amendments were adopted to attain this end by law rather than by force, intimidation or fraud. In addition to a new registration law, already in vogue, the Mississippi constitution of 1890 required that a prospective voter be registered, a payer of a poll tax, and, after 1 Jan. 1892, able to read any portion of the constitution or to understand it when read to him, or to render a reasonably accurate interpretation of it. The South Carolina constitution of 1895 permitted the registration of an otherwise qualified person, "provided that he can both read and write any section of this constitution submitted to him by the registration officer, or can show that he owns and has paid all taxes collectible during the previous year on property in this State assessed at \$300 or more." The Louisiana constitution of 1898 contained similar clauses, but for would-be voters, who might be excluded by these tests, the constitution provided that any male person "who was on January 1, 1867, or at any date prior thereto, entitled to vote under the constitution or statutes of any State of the United States, wherein he then resided, and any son or grandson of any such person not less than twenty-one years of age at the date of the adoption of this Constitution" should be allowed to register and vote at all elections without possessing the educational or property qualifications. In 1901 Alabama incorporated a provision requiring that voters be of "good character" and "understand the duties and obligations of citizenship under a republican form of government." Virginia has imitated this qualification. (See also UNITED STATES—SUFFRAGE IN THE). The constitutionality of these provisions has not been definitely decided by the Supreme Court, though several cases have been considered. Regarding the Mississippi constitution (*Williams vs. Mississippi*, 170 U. S. 213), the Court declared that the qualifications did not "on their face discriminate between the white and negro races, nor amount to a denial of the equal protection of the law secured by the Fourteenth Amendment to the Constitution; and it has not been shown that their actual administration was evil, but only that evil was possible under them." The Court further stated (*Giles vs. Harris*, 189 U. S. 474) — "Relief from a great political wrong, if done as alleged, by the people of a State, or by the State itself, must be given by them, or by the legislative and political departments of the government of the United States."

On 21 June 1915 the Supreme Court declared void the "grandfather clauses" of the Maryland and Oklahoma constitutions. In Maryland the clause was inserted in laws governing elections in various cities. In 1908 it

was inserted in the law governing municipal elections in the city of Annapolis. It authorized the registration as voters of all taxpayers of the city assessed for at least \$500; all duly naturalized citizens, all male children of naturalized citizens 21 years of age, and "all citizens who prior to Jan. 1, 1868, were entitled to vote in the State of Maryland or any other State of the United States at a State election, and the lawful male descendants of any person who prior to Jan. 1, 1868, were entitled to vote in the State of Maryland or in any other State of the United States at a State election." The constitution of Oklahoma, upon which that Territory was admitted to the Union as a State, gave something very like manhood suffrage. Prior to the election of 1910, however, an amendment was adopted restricting the franchise. The amendment in part was as follows:

"No person shall be registered as an elector of this State or be allowed to vote in any election herein unless he shall be able to read and write any section of the Constitution of the State of Oklahoma; but no person who was on Jan. 1, 1866, or at any time prior thereto, entitled to vote under any form of government, or who at any time resided in some foreign nation and no lineal descendant of such person shall be denied the right to register and vote because of his inability to so read and write sections of such Constitution."

The contentions of the election officers as plaintiffs in error, really setting forth the position of the State, are thus outlined by the chief justice:

"It said the States have the power to fix standards for suffrage and that power was not taken away by the Fifteenth Amendment, but only limited to the extent of the prohibitions which the amendment established. This being true, as the standard fixed does not in terms make any discrimination on account of race, color or previous condition of servitude, since all, whether negro or white, who come within its requirements, enjoy the privilege of voting, there is no ground upon which to rest the contention that the provision violates the Fifteenth Amendment. This, it is insisted, must be the case unless it is intended to expressly deny the State's right to provide a standard for suffrage, or what is equivalent thereto, to assert: (a) That the judgment of the State exercised in the execution of that power is subject to Federal judicial review or to supervision, or (b) that it may be questioned or be brought within the prohibitions of the amendment by attributing to the legislative authority an occult motive to violate the amendment or by assuming that an exercise of the otherwise lawful power may be invalidated because of conclusions concerning its operation in practical execution and resulting discrimination arising therefrom, albeit such discrimination was not expressed in the standard fixed or fairly to be implied, but simply arose from inequalities naturally inhering in those who must come within the standard in order to enjoy the right to vote."

The government insisted, on the other hand, that the "real question involved is the repugnancy of the standard which the amendment makes, based upon the conditions existing on Jan. 1, 1866, because on its face and inherently considering the substance of things, that standard is a mere denial of the restrictions imposed by the prohibitions of the Fifteenth Amendment and by necessary result creates and perpetuates the very conditions which the amendment was intended to destroy."

The chief justice summed up the opinion of the court in these words:

"There seems no escape from the conclusion that to hold that there was even possibility for dispute on the subject would be but to declare that the Fifteenth Amendment not only had the self-executing power which it has been recognized to have from the beginning, but that its provisions were wholly inoperative because susceptible of being rendered inapplicable by mere forms of expression embodying no exercise of judgment and resting upon no discernible reason other than the purpose to disregard the prohibitions of the amendment by creating a standard of voting which on its face was in substance but a revitalization of the conditions which, when they prevailed in the past, had been destroyed by the self-operative force of the amendment. It



is true it contains no express words of an exclusion, from the standard which it established, of any persons on account of race, color, or previous condition of servitude prohibited by the Fifteenth Amendment, but the standard itself inherently brings that result to existence, since it is based purely on a period of time before the enactment of the Fifteenth Amendment and makes that period the controlling and dominant test of the right of suffrage.

"We are unable to discover how, unless the prohibitions of the Fifteenth Amendment were considered, the slightest reason was afforded for basing the classification upon a period of time prior to the Fifteenth Amendment. Certainly it cannot be said that there was any peculiar necromancy in the time named which engendered attributes affecting the qualification to vote which would not exist at another and different period unless the Fifteenth Amendment was in view."

The Court took the view that under ordinary circumstances the State should decide the question whether the nullification of the exceptions of the grandfather clause would at the same time make void the general literacy test to which it was appended. In the absence of a decision by a State court the Chief Justice, however, said that the Federal tribunal would pass upon the question. Ordinarily a provision like the literacy test, which is legal in itself, would not be destroyed by the wiping out of an illegal accompanying provision. But the plain meaning of the Oklahoma constitution was that the reading test should not be used to disqualify lineal descendants of voters prior to 1866. As this would be accomplished in many cases by continuing the reading test without the offensive exemptions, the whole provision was stricken out. Accordingly in 1916 the Oklahoma legislature passed a proposed constitutional amendment (approved by the governor 21 Feb. 1916), which prohibited any property qualification; it contained the reading and writing clause but this clause was inoperative if, prior to the adoption of the amendment, a prospective elector had served in the land or naval forces of the United States or of any State or foreign nation, or in the Revolution, War of 1812, Mexican War, or on either side in the Indian wars or the Civil War; and all lawful descendants of such persons were included. But this amendment was rejected at the election of August 1916 and now the only restriction on suffrage in Oklahoma is a universal registration act passed by a special session of the legislature in 1916.

**Residence and Absentee Voting.**—Generally speaking, an elector must vote in the precinct wherein he resides, if he have a fixed place of abode. As employed in the statutes and constitutions in defining political rights, a residence is synonymous with home or domicile, denoting a permanent dwelling place to which the party when absent intends to return. An absence for months or even years, provided the party intended it merely as a temporary arrangement, after which he would occupy his former home, would not constitute an abandonment of such residence or home or deprive the party of his right to vote thereat. But the mere act of abiding in a place for a definite time and for a specific purpose, with no present intention of remaining and making it a permanent home, would not constitute a residence entitling the party to vote. A person who removes from the jurisdiction, intending to remain, thereby loses his residence, even though he may afterward change his intention and return; nor can he vote until he has re-estab-

lished his residence by remaining in the jurisdiction the statutory period. Courts have held, however, that where a person is a bona-fide resident of a county but has no fixed residence or domicile in any particular precinct therein, he may vote in any precinct wherein he may happen to be on election day. In 1915 Vermont enacted a law permitting a voter who changed his residence within 15 days prior to election to vote in the town to which he moved; conversely Connecticut and California allowed the voter to retain a voting residence in the town from which he moved. Colorado, Iowa, Michigan, Montana, Washington and Wisconsin passed laws permitting voters absent from their home precincts to vote elsewhere in the State. In 1916 Virginia and Oklahoma provided for absentee voting, the former allowing absent electors to vote by registered mail and the latter permitting an elector absent from his county to vote in another precinct. Absentee voting occurs sometimes when large bodies of citizens are called into some branch of governmental service, such as the army; this happened in the elections of 1916 and 1917 when the National Guard troops were on the Mexican border, or in France or in cantonments preparing for service abroad, special provisions being made for the balloting at the camps. In the election of November 1917 Massachusetts adopted an amendment enabling the legislature to establish arrangements for absentee voting.

#### **Voting in Territories and Dependencies.**

—As previously stated, residents of the District of Columbia do not vote, the government being in the hands of a board of commissioners appointed by the President. From 1802 to 1855 white taxpayers were permitted to vote for local officers; subsequently the taxpaying qualification was eliminated; in 1867 all adult male citizens white or black were granted the franchise if not disqualified by the Fourteenth Amendment; but in 1874 all suffrage rights were abrogated. Prior to becoming a territory of the United States, Hawaii required that electors of members of the senate be possessed of a substantial amount of property, but under the organic act of 1900 all persons may vote who are duly registered citizens of the United States, 21 years of age, resident in the islands one year or more, and who can speak, read and write either the English or Hawaiian language; hence Chinese and Japanese are excluded. In Porto Rico all male citizens, 21 years of age or over, who had resided in the island one year might vote if they passed a property or an educational test similar to that of South Carolina, but in 1904 a law was passed renewing the property qualification and requiring that after 1906 all registrants should be able to read and write, but permitting those who already were voters to continue their exercise of the voting privilege. In 1907, in his proclamation for an election of delegates to the Philippine assembly, President Roosevelt denied the right of representation to the Moros and other non-Christian tribes, and required that each voter be capable of reading, writing or speaking English or Spanish, that he be an owner of property or a taxpayer, and that he take an oath of allegiance. In Alaska both men and women enjoy full suffrage rights.

ELECTORAL QUALIFICATIONS

STATES AND TERRITORIES	Citizenship requirements			Previous residence		Persons excluded from suffrage	Educational tests	Tax or property tests	Alternative tests
	State	County	Town	Pre-cinct					
ALABAMA <sup>1</sup> .....	Male, 21 years old, citizen U. S.; or alien who has declared intentions.	1 yr.	3 mos.	3 mos.	Idiots; insane; persons convicted of treason or other felonies; vagrants; persons convicted of election frauds.	A.* Ability to read and write any article of U. S. Constitution in English and regularly engaged in some lawful employment, business or occupation for greater part of preceding year.	1. Payment of all poll taxes due since 1901. B.* Ownership of (personally or through wife) for preceding year on 40 acres of land in State; or personal property assessed at \$300 or more.	Right of permanent registration as electors (28 Nov. 1901 — 20 Dec. 1902) if: 1. All who had served honorably in War of 1812, Mexican War, Indian wars, Civil War, Spanish American War, in the land and naval forces of Confederacy or Alabama; or 2. Lawful descendants of such veterans (this including the Revolution); or 3. Persons of good character who understand the duties and obligations of citizenship under a republican form of government.	
ALASKA.....	Male or female, citizen of U. S.	1 yr.	30 d.	30 d.	Aliens and Indians.	Read U. S. Constitution in English and write name.	Payers of taxes on property only may vote on questions of bond issues or special assessments.	Persons who in 1911 were 60 years of age or upwards.	
ARIZONA <sup>1</sup> .....	Male or female, 21 years old, citizen of U. S.; or Mexican citizens who wish to become citizens of Arizona under treaties of 1848 and 1854.	1 yr.	30 d.	30 d.	Idiots; insane; felons; U. S. soldiers, sailors and marines; persons convicted of treason.	Read U. S. Constitution in English and write name.	Payment of poll tax.		
ARKANSAS <sup>1</sup> .....	Male, 21 years old, citizen of U. S.; or alien who has declared intentions.	1 yr.	6 mos.	30 d.	Idiots; insane; felons; persons convicted of election frauds; U. S. soldiers, sailors and marines.	Read constitution in English; write name.			
CALIFORNIA <sup>1</sup> .....	Male or female, 21 years old, citizen of U. S. by nativity or by naturalization 90 days before election; or persons who have acquired rights of citizenship under treaty of Queretaro.	1 yr.	90 d.	30 d.	Chinese; idiots; insane; persons convicted of infamous crime or of embezzlement of public funds.	Read constitution in English; write name.			
COLORADO <sup>1</sup> .....	Male or female, 21 years old, citizen of U. S.; or alien who has declared intentions 4 mos. before election.	1 yr.	90 d.	30 d.	Insane; felons.....	Legislature may prescribe tests by law.			
CONNECTICUT <sup>1</sup> .....	Male, 21 years old, citizen of U. S. <sup>2</sup>	1 yr.	6 mos.	30 d.	Bribers; forgers; perjurers; delinquents; fraudulent bankrupts; persons convicted of other infamous crimes.	Read any article of State constitution in any section of statutes shall sustain "a good moral character."			

State	Qualification	Age	Residence	Disqualifications	Other	Notes
DELAWARE	Male, 21 years old, citizen of U. S. (Note 3 applies to women in some districts).	1 yr.	3 mos.	30 d.	Idiots; insane; felons; paupers; persons convicted of election fraud; U. S. soldiers, sailors and marines.	If 21 years old after 1 Jan. 1900, read constitution in English and write his name.
FLORIDA	Male, 21 years old, citizen of U. S.	1 yr.	6 mos.	?	Persons under guardianship; non-compos mentis or insane; felons; duellists; election betrayers.	Payment of capitation tax.
GEORGIA	Male, 21 years old, citizen of U. S.	1 yr.	6 mos.	?	U. S. soldiers, sailors and marines; idiots; insane; persons convicted of treason, embezzlement of public funds or other felonies.	A.* Read and write in English any paragraph of U. S. or Georgia constitutions. B.* Ownership of and residence on 40 acres of land in State; or property in State assessed at \$500 or more. C.* All who have served honorably in any war of U. S. or in land or naval forces of Confederacy or of Georgia. D.* Lawful descendants of such veterans. E.* Persons "of good moral character who understand the duties and obligations of citizenship under a republican form of government."
HAWAII	Male, 21 years old, citizen of U. S.	1 yr.	?	3 mos.	Idiots; insane; felons.	Speak, read or write the English or Hawaiian language.
IDAHO	Male or female, 21 years old, citizen of U. S.	6 mos.	30 d.	?	Persons under guardianship; idiots; insane; persons convicted of treason, felony, embezzlement of public funds; bigamists or polygamists; Chinese or persons of Mongolian descent not born in U. S.; Indians not taxed, who have not severed tribal relations.	Constitution prohibits property qualifications, except in school elections or elections creating indebtedness.
ILLINOIS	Male or female, 21 years old, citizen of U. S.	1 yr.	90 d.	30 d.	U. S. soldiers, seamen and marines; persons convicted of infamous crimes.	
INDIANA	Male, 21 years old, citizen of U. S.; or alien resident in U. S. one year who has declared intentions. On 26 Oct. 1917, the Indiana Supreme Court held the woman suffrage law passed by the legislature to be unconstitutional.	6 mos.	?	30 d.	U. S. soldiers, sailors and marines; persons convicted of infamous crimes.	

ELECTORAL QUALIFICATIONS

STATES AND TERRITORIES	Citizenship requirements	Previous residence			Persons excluded from suffrage	Educational tests	Tax or property tests	Alternative tests
		State	County	Town				
LOWA	Male, 21 years old, citizen of U. S.	6 mos.	60 d.	10 d.	U. S. soldiers, sailors and marines; idiots; insane; persons convicted of infamous crimes.			
KANSAS	Male or female, 21 years old, citizen of U. S.; or alien who has declared intentions.	6 mos.	30 d.	30 d.	U. S. soldiers, sailors and marines; insane; idiots; bribers; rebels or traitors; persons convicted of felony.			
KENTUCKY	Male, 21 years old, citizen of U. S.	1 yr.	6 mos.	60 d.	Persons convicted of treason, felony or bribery; idiots; insane; U. S. soldiers, sailors and marines.		Poll tax in counties, cities or towns where required.	
LOUISIANA	Male, 21 years old, citizen of U. S.	2 yrs.	1 yr.	6 mos.	Idiot; insane; felons; inmates of charitable institutions except Soldiers' Home.		Ownership of property in State assessed at not less than \$300 on which all taxes have been paid. Exhibit poll tax receipts for two years next preceding election.	C. * Special registration (16 May 1898 — 31 Aug. 1898) to give permanent suffrage rights to those who lacked A and B, but who could vote on or before 1 Jan. 1867; or any son or grand-son of such person; or any alien naturalized in U. S. prior to 1 Jan. 1898. Date of registration was extended by amendment in 1912.
MAINE	Male, 21 years old, citizen of U. S.	3 mos.	3 mos.	3 mos.	Paupers; Indians not taxed; U. S. soldiers, sailors and marines.			
MARYLAND	Male, 21 years old, citizen of U. S.	1 yr.	6 mos.	1 d.	Felons; lunatics; idiots; bribers.			The Grandfather clause of 1908 relating to Annapolis declared unconstitutional by U. S. Supreme Court in 1915.
MASSACHUSETTS	Male, 21 years old, citizen of U. S.	1 yr.	6 mos.	6 mos.	Paupers.			

# ELECTORAL QUALIFICATIONS

State	Qualification	Age	Residence	Disqualifications	Other	Notes
MICHIGAN	Male, 21 years old, citizen of U. S.; or alien who has resided in State 2 years 6 months prior to 8 Nov. 1894 and had declared intention; civilized male of Indian descent, native of U. S., not a member of any tribe. <sup>3</sup>	20 d.	30 q.	20 d.	6 mos.	U. S. soldiers, sailors and marines.
OHIO	Male, 21 years old, citizen of U. S. for 3 months next preceding any election; persons of mixed white and Indian blood who have adopted customs and habits of civilization; civilized persons of Indian blood pronounced by a court capable of enjoying rights of citizenship in State. <sup>3</sup>	30 d.	30 q.	30 d.	6 mos.	Persons convicted of treason, felons; idiots; insane; U. S. soldiers, sailors and marines.
MINNESOTA	Male, 21 years old, citizen of U. S. for 3 months next preceding any election; persons of mixed white and Indian blood who have adopted customs and habits of civilization; civilized persons of Indian blood pronounced by a court capable of enjoying rights of citizenship in State. <sup>3</sup>	30 d.	30 q.	30 d.	6 mos.	Persons convicted of treason, felons; idiots; insane; U. S. soldiers, sailors and marines.
MISSISSIPPI	Male, 21 years old, citizen of U. S.	1 yr.	1 yr.	1 yr.	2 yrs.	Idiot; insane; Indians not taxed; felons; bribers; bigamists.
MISSOURI	Male, 21 years old, citizen of U. S.; or alien who has declared intention 1-5 years before he offers to vote. <sup>3</sup>	60 d.	60 d.	60 d.	1 yr.	Persons kept at any poor-house or other asylum at public expense or confined in any public prison; U. S. soldiers, sailors and marines.
MONTANA	Male or female, 21 years old, citizen of U. S.	30 d.	30 d.	30 d.	1 yr.	Felons; idiots; insane; U. S. soldiers, sailors and marines.
NEBRASKA	Male, 21 years old, citizen of U. S.; or aliens who have declared intentions 30 days prior to an election. <sup>3</sup>	40 d.	10 d.	10 d.	6 mos.	Idiot; insane; persons convicted of treason or felony; U. S. soldiers, sailors and marines.
NEVADA	Male or female, 21 years old, citizen of U. S.	30 d.	30 d.	30 d.	6 mos.	Idiot; insane; persons convicted of treason or felony.
NEW HAMPSHIRE	Male, 21 years of age, citizen of U. S. <sup>3</sup>	6 mos.	6 mos.	6 mos.	6 mos.	Idiot; insane; felons; paupers.
NEW JERSEY	Male, 21 years old, citizen of U. S. <sup>3</sup>	1 yr.	5 mos.	5 mos.	1 yr.	U. S. soldiers, sailors and marines; idiots; insane; felons; bribers.

ELECTORAL QUALIFICATIONS

STATES AND TERRITORIES	Citizenship requirements	Previous residence				Persons excluded from suffrage	Educational tests	Tax or property tests	Alternative tests
		State	County	Town	Pre-cinct				
NEW MEXICO	Male, 21 years old, citizen of U. S.	1 yr.	90 d.	:	30 d.	Idiots; insane; felons; Indians not taxed; women at school elections if majority of qualified electors of school district petition against women voting 30 days prior to school election.	The constitution prohibits restriction, abridgement or impairment of the right of citizens to vote, hold office or sit on juries, on account of religion, race, language or color, or inability to speak, read or write the English or Spanish languages.		
NEW YORK	Male, 21 years old, citizen of U. S., or naturalized 90 days prior to election. Full woman suffrage obtained at election of November 1917, effective 1918.	1 yr.	4 mos.	:	30 d.	Election bribers or betters; persons convicted of infamous crime. Persons kept in almshouse or other asylum or confined in public prison not disqualified.	.....	In order to vote at any school meeting, the elector must own taxable real estate in the district or personal property assessed at \$50 or more, exclusive of property exempt from taxation, unless such elector have children of school age living with him.	
NORTH CAROLINA	Male, 21 years old, citizen of U. S.	2 yrs.	6 mos.	4 mos.	4 mos.	Felons; persons guilty of treason, corruption or malpractice in office; persons who deny the being of Almighty God.	A.* Ability to read and write any section of State constitution in English.	Payment of poll tax for preceding year on or before 1 May of year of election.	B.* No male who on 1 Jan. 1867 could vote in any State nor any lineal descendant of such person shall be denied right to register and vote because of educational disqualifications, provided he registered prior to 1 Dec. 1908.
NORTH DAKOTA	Male, 21 years old, citizen of U. S.; civilized persons of Indian descent who have severed tribal relations two years preceding election.	1 yr.	6 mos.	90 d.	90 d.	Idiots; insane; persons convicted of treason or felony; U. S. soldiers, sailors and marines.	Legislature may by law establish an educational test.		
OHIO	Male, 21 years old, citizen of U. S.	1 yr.	30 d.	20 d.	20 d.	Idiots; insane; persons convicted of bribery, perjury or other infamous crimes; U. S. soldiers, sailors and marines.			

ELECTORAL QUALIFICATIONS

	1 yr.	6 mos.	30 d.		A.* Read and write any section of State constitution.	B.* No person who on 1 Jan. 1866 was entitled to vote in any State or who then resided in some foreign nation and no lineal descendant of such person shall be denied the right to register and vote because of inability to read and write State constitution (Adopted at election 2 Aug. 1910 but in 1915 Sup. Ct. as discriminating against negro race passed constitutional amendment prohibiting any property qualification and containing the reading and writing clause, but this clause was to be inoperative if, prior to adoption of amendment, prospective elector had served in land or naval forces of U. S. or of any State or foreign nation or in the Revolution, War of 1812, Mexican War, or on either side in the Indian wars or the Civil War, or if elector were a lawful descendant of such person. This amendment was rejected in 1916 at a special election and now the only restriction on suffrage is a universal registration act passed by a special session of the legislature in 1916.
OKLAHOMA	Male, 21 years old, citizen of U. S.; citizen of Oklahoma; male of Indian descent, native of U. S.	1 yr.	30 d.	Idiot; lunatics; felons; persons kept in asylum at public expense, except Federal and Confederate ex-soldiers; U. S. soldiers, sailors and marines.		
OREGON	Male or female, 21 years old, citizen of U. S.	6 mos.	2	Idiot; insane; U. S. soldiers, sailors and marines; felons.		
PENNSYLVANIA	Male, 21 years old, citizen of U. S. at least one month.	1 yr.	2 mos.	Bribers; felons		If 22 years or more, the elector shall have paid within 2 years a State or county tax assessed at least 2 months and paid at least 1 month before the election.
PORTO RICO	Male, 21 years old, citizen of U. S., or native Porto Ricans who formally renounced allegiance to a foreign power.	1 yr.	2	Felons; insane; U. S. soldiers, sailors and marines.		
RHODE ISLAND	Male, 21 years old, citizen of U. S.	2 yrs.	2	U. S. soldiers, sailors and marines; paupers; insane; felons; Narragansett Indians.		Ownership of real estate assessed at \$134 above all encumbrances in order to vote in election of city council or upon any proposition to impose a tax. A school tax of \$1 is assessed annually on all persons eligible to register.

ELECTORAL QUALIFICATIONS

STATES AND TERRITORIES	Citizenship requirements		Previous residence			Persons excluded from suffrage	Educational tests	Tax or property tests	Alternative tests
	State	County	Town	Pre-cinct					
SOUTH CAROLINA.	Male, 21 years old, citizen of U. S. and of S. C.	1 yr.	4 mos.	4 mos.		Felons; bribers; bigamists; violators of election laws; idiots; insane; paupers.	A.* Read and write any section of State constitution. (From 1895, up to 1 Jan., 1898, male persons of voting age might become qualified for life on proving ability to read any section of constitution or understand and explain it when read to them).	Payment 6 months before any election of any poll tax then due. Proof of payment of all taxes, including poll tax, assessed against him, and collectible during previous year. B.* Proof of ownership of and payment of taxes during previous year on property in State assessed at \$300 or more.	
SOUTH DAKOTA 1.	Male, 21 years old, citizen of U. S.; or alien who has declared intentions. Residence of 1 year in U. S. required. <sup>3</sup>	6 mos.	30 d.	2		Insane; felons; persons convicted of treason; U. S. soldiers, sailors, and marines.		Proof of payment of poll taxes assessed against him. All male citizens must pay poll taxes and perform prescribed military duty.	
TENNESSEE 1.....	Male, 21 years old, citizen of U. S.	1 yr.	6 mos.	2	2	Felons.....		In all elections to determine expenditure of money or taxpayers of debt, taxpayers only may vote in such city or town. Payment of poll-tax.	
TEXAS 1.....	Male, 21 years old, citizen of U. S.; or alien who has declared intentions 6 months prior to election.	1 yr.	6 mos.	2	6 mos.	Idiot; lunatics; paupers; felons; U. S. soldiers, sailors and marines.		Property tax payment required of voters in elections levying a special tax or creating indebtedness.	
UTAH 1.....	Male or female, 21 years old, citizen of U. S. Naturalization completed 90 days before election.	1 yr.	4 mos.	2	60 d.	Idiot; insane; felons; persons convicted of treason.		Payment of State poll tax (not required of any person who fought on either side "during the late war between the States").	
VERMONT 1.....	Male, 21 years old, citizen of U. S. <sup>3</sup>	1 yr.	3 mos.	3 mos.	3 mos.	Bribers.			
VIRGINIA 1.....	Male, 21 years old, citizen of U. S.	2 yrs.	1 yr.	30 d.	30 d.	Idiot; insane; paupers; felons; duellists; perjury; treason or perjury; U. S. soldiers, sailors and marines.	A.* Registration 1902-03. Ability to read and explain any section of State constitution or understand and give reasonable ex-		



ELECTORAL QUALIFICATIONS

planations thereof when read to him.

D. Registration 1902-03. A son of any each person.

WASHINGTON	Male or female, 21 years old, citizen of U. S.	1 yr.	90 d.	30 d.	30 d.	Indians not taxed; idiots; insane; felons.	A. Since 1 Jan. 1904, make application in own hand writing with-out aid, suggestion or memorandum, stating name, age, date and place of birth, residence and occupation at the time and for two years next preceding, and when and where he previously voted.	B. Since 1 Jan. 1904, payment of all State poll-taxes assessed against him for three years next preceding or payment of \$1.50 if he come of age at such time that no poll tax shall have been assessed against him for year preceding year in which he offers to register.
WEST VIRGINIA	Male, 21 years old, citizen of U. S.	1 yr.	60 d.	?	?	Insane; paupers; felons; persons convicted of bribery or treason; U. S. soldiers, sailors and marines.		
WISCONSIN	Male, 21 years old, citizen of U. S., till 1 Dec. 1912, aliens who declared intention before 1 Dec. 1908. Indians declared citizens of U. S. by act of Congress; civilized Indians not members of any tribe.	1 yr.	?	10 d.	10 d.	Idiot; felons; U. S. soldiers, sailors and marines.		
WYOMING	Male or female, 21 years old, citizen of U. S.	1 yr.	60 d.	?	?	Idiot; insane; felons; U. S. soldiers, sailors and marines.	Read State constitution.	

NOTES.—\* Sections marked by asterisks indicate tests which are options one for another. Voters are required to qualify under only one test. in force. —\* No specified time. —\* Modified woman suffrage, women with same age and residence qualifications as male voters being allowed to vote at certain elections, for certain officers or on special propositions (such as tax assessments; bond issues; school officers; or upon any question relating to education or to schools; or for statutory but not for constitutional officers). —\* Under the State law of 1913 in Illinois it was construed that women could vote for Presidential electors, members of the State board of equalization, clerk of the appellate court, county collector, county surveyor, members of board of assessors, members of board of review, sanitary district trustees and for all the officers of cities, villages and towns (except police magistrates), municipal judges and upon all questions or propositions submitted for approval at elections. The Supreme Court of Illinois ruled, February 1916, that women cannot vote for national delegates and alternates. The court also held that women cannot vote for State central committeemen and precinct committeemen. —\* Clergymen are qualified after six months' residence in precinct. —\* Ministers in charge of an organized church and public school teachers may vote after a residence of six months in the State.

## TERMS OF AND QUALIFICATIONS FOR OFFICE.

**Federal.**—Presidents are elected for four years, senators for six years and representatives for two years. Article VI, § 3 of the Constitution requires that senators and representatives, members of State legislatures and all executive and judicial officers, State and National, "shall be bound by oath or affirmation" to support the Constitution, but "no religious test shall ever be required as a qualification to any office or public trust under the United States." No senator, representative or Federal office holder may be a Presidential elector (Art. II, § 1, ¶ 2). The Constitution states that "no person except a natural born citizen, or a citizen of the United States at the time of the adoption of this Constitution, shall be eligible to the office of President; neither shall any person be eligible to that office who shall not have attained to the age of thirty-five years and been fourteen years a resident within the United States." (Art. II, § 1, ¶ 5). Hence, foreign-born citizens are excluded from this office but children born of parents residing abroad temporarily are not considered foreign-born. No restriction is placed by the Constitution upon the number of terms a President may serve but Washington's precedent of two terms has always been followed. A senator must be at least 30 years old, nine years a citizen of the United States and at the time of election an inhabitant of the State represented. A member of the House must be at least 25 years of age, seven years a citizen of the United States and at the time of election an inhabitant of the State represented (Art. I, § 2, ¶ 2, § 3, ¶ 3). This does not prevent their establishing homes in Washington while maintaining their legal residences in the States represented. Article I, § 6, ¶ 2, says: "No Senator or Representative shall, during the time for which he was elected, be appointed to any civic office under the authority of the United States which shall have been created or the emoluments whereof shall have been increased during such time; and no person holding any office under the United States shall be a member of either House during his continuance in office." Accordingly, if a senator or representative accept any Federal office, his seat in Congress thereby becomes vacant, but if an office-holder be elected to either branch of Congress he may retain his position until his active duties in the legislature begin, whereupon the other office becomes vacant. Regarding the judiciary the Constitution makes no stipulations, the justices being appointed by the President with the advice and consent of the Senate. The same provision holds true of Cabinet officials, save that no one interested in the import trade may become Secretary of the Treasury; though all members of the Cabinet are expected to sever all business or outside connections. (See CABINET AND CABINET GOVERNMENT; EXECUTIVE). All other Federal offices are filled by appointment, which is subject only to the restrictions and limitations of custom or Congressional enactments. Appointive offices may be held by women, minors or aliens. See APPOINTMENTS TO OFFICE; TENURE OF OFFICE.

**State.**—The States quite effectively control their office-holders. The only stipulation in the Constitution as first adopted regarding State

office-holders was that they should "be bound by oath or affirmation" to support the Constitution (Art. VI, § 3). The Fourteenth and Fifteenth Amendments provided that "No State shall make or enforce any law which shall abridge the privileges or immunities of citizens of the United States" and that "the right of citizens of the United States to vote shall not be denied or abridged by the United States or by any State on account of race, color or previous condition of servitude." Hence any law enacted by a State which expressly deprives a negro citizen of the right to vote or to hold office would be unconstitutional, but the courts have upheld laws which indirectly disqualify certain classes of negroes and therefore they cannot hold office. In the early State constitutions are to be found numerous religious tests for office-holders. The man possessing moderate means might vote, but legislation was restricted to well-to-do Christians, and in some States none but a rich Christian could aspire to the governorship. In New Hampshire, New Jersey and South Carolina, no Hebrew, atheist or Roman Catholic could become governor and none but a Christian in Massachusetts, Delaware, Pennsylvania, Maryland and South Carolina. Maryland did not open public offices to Jews until 1826. In some New England States church members alone could vote, while the South Carolina constitution of 1778 extended the privilege to "every free white man, and no other person, who acknowledges the being of a God, and believes in a future state of rewards and punishments." The early constitutions also required in many cases that office-holders be "Christians," or "of the Protestant religion," or should believe "in the Trinity and Inspiration of the Scriptures" (Delaware 1776), or should declare themselves "to be of the Christian religion" (Massachusetts 1780). In New York, Delaware, Maryland and Georgia no priest nor minister of any creed could hold a civil office, though in Georgia the prohibition is limited to the assembly. (Wiley, Edwin, and Rines, Irving E., 'The United States,' Vol. V, pp. 98-99). Indeed, as McMaster says:

"The government set up by many a constitution, despite the principle announced in its preamble, was that of a class. Nowhere, save in Vermont, did manhood suffrage exist. Elsewhere, no man voted who did not pay a property tax, or rent a house, or own a specified number of acres of land, or have a specified yearly income. Each one of the State constitutions guaranteed liberty of conscience; but the man who did not exercise that liberty of conscience in such wise as to become a Protestant or a Catholic, a trinitarian or a believer in the divine inspiration of the Old and New Testaments must give up all hope of political preferment. Even to such as could subscribe to creeds and doctrines, the way to public office was barred by property qualifications, which increased with the dignity of the office until it became absolutely impossible for a poor man to become a candidate for the State senate or the governorship." (McMaster, J. B., 'History of the People of the United States,' Vol. V, p. 377).

Most of these requirements have been eliminated, though eight States still retain remnants, among them being South Carolina, whose constitution of 1895 (Art. IV, § 3) provides that no one may be governor "who denies the existence of the Supreme Being." Property qualifications also have been eliminated gradually from the State constitutions. In our early history religious qualifications were not deemed sufficient; heavy property qualifications were added, especially for executive officers, for the governor must not only be pious but rich; the

importance of the office determined the amount of property. According to the South Carolina constitution of 1775 governors and lieutenant-governors "shall have in this State a settled plantation or freehold in their and each of their own right of the value of at least ten thousand pounds currency, clear of debt," while the estate of a senator must be valued at £2,000 currency and of a representative £3,500. The Massachusetts constitution of 1780 provided that senators must possess a freehold of the value of £300 or personal estate of at least

must be possessed and continue to be possessed in fee simple or for life of a freehold of 100 acres of land; in Georgia he must own 250 acres of land or property worth £250. Usually the qualifications for membership in the upper house were the same as those for the lower house, save that values were twice as great. Some of the recent constitutions of the Southern States contain provisions regarding property or payment of taxes incorporated with the object of excluding negroes from voting and holding office.

STATES	Governor			Senators			Representatives		
	Term of office	Age limit	Residence in state	Term of office	Age limit	Residence in state	Term of office	Age limit	Residence in state
Alabama	4	30	7	4	25	3	4	21	3
Arizona	2	25	5	2	25	3	2	25	3
Arkansas	2	30	7	4	25	2	2	21	2
California	4	25	5	4	21	3	2	21	3
Colorado	2	30	2	4	25	1	2	25	1
Connecticut	2	30	*	2	*	*	2	*	*
Delaware	4	30	6	4	27	3	2	24	3
Florida	4	†	5	4	†	†	2	†	†
Georgia	2	30	6	2	25	4	2	21	†
Idaho	2	30	2	2	2	†	2	†	†
Illinois	4	30	5	4	25	5	2	21	5
Indiana	4	30	5	4	25	2	2	21	2
Iowa	2	30	2	4	25	1	2	21	1
Kansas	2	21	*	4	†	6 mos.	2	†	6 mos.
Kentucky	4	30	6	4	30	6	2	24	2
Louisiana	4	30	10	4	25	5	4	21	5
Maine	2	30	5	2	25	1	2	†	1
Maryland	4	30	5	4	25	3	2	21	3
Massachusetts	1	*	7	1	1	5	1	*	*
Michigan	2	30	2	2	†	†	2	†	†
Minnesota	2	25	1	4	†	†	2	†	†
Mississippi	4	30	5	4	25	4	4	21	4
Missouri	4	35	7	4	30	3	2	24	2
Montana	4	30	2	4	24	1	2	21	1
Nebraska	2	30	2	2	†	†	2	†	†
Nevada	4	25	2	4	†	†	2	†	†
New Hampshire	2	30	7	2	30	7	2	†	†
New Jersey	3	30	7	3	30	4	1	21	2
New Mexico	2	30	5	4	25	3	2	21	3
New York	2	30	5	2	21	*	1	21	*
North Carolina	4	30	2	2	25	2	2	21	*
North Dakota	2	30	5	4	25	2	2	21	2
Ohio	2	*	†	2	*	*	2	*	*
Oklahoma	4	30	3	4	25	†	2	21	†
Oregon	4	30	3	4	21	1	2	21	1
Pennsylvania	4	30	7	4	25	4	2	21	4
Rhode Island	2	†	†	2	†	†	2	†	†
South Carolina	2	30	5	4	25	2	2	21	†
South Dakota	2	30	2	2	25	2	2	25	2
Tennessee	2	30	7	2	30	3	2	21	3
Texas	2	30	5	4	26	5	2	21	2
Utah	4	30	5	4	25	3	2	25	3
Vermont	2	*	4	2	30	*	2	*	*
Virginia	4	30	5	4	†	†	2	†	†
Washington	4	†	†	4	†	†	2	†	†
West Virginia	4	30	5	4	25	5	2	†	†
Wisconsin	2	†	†	4	†	†	2	†	†
Wyoming	4	30	5	4	25	1	2	21	1

\* Not stated in constitution.  
 † Merely a duly qualified elector. See preceding table.  
 ‡ No specified time required.

£600; representatives must have a freehold of £100 or "any ratable estate" to the value of £200; and a governor "must be seised, in his own right, of a freehold, within the commonwealth, of the value of £1,000." In New Hampshire eligibility to the lower branch of the legislature consisted of being a Protestant and possessing an estate worth £100; a freehold of £100 above all debts in New York; a "personal estate" in New Jersey; a freehold of £500 in Maryland; in North Carolina an assemblyman

Some of the early constitutions required that a governor should be native born, but Connecticut (1818) merely required citizenship, Massachusetts (1817) a citizenship of 20 years and Illinois (1818) a citizenship of 30 years. At the present time citizenship is almost universally required of a State office-holder but the term of residence varies widely—from the bare fact of residence to residence for 10 years next preceding the election. The same variance is seen in the age requirements, ranging

from 21 to 35 for governors, 21 to 30 for senators and 21 to 25 for representatives while in some States the only requirement for the last two offices is to be a duly qualified elector and some constitutions contain no limitations whatever. The preceding table gives the terms of office of governors and State senators and representatives, together with their age requirements and the necessary period of residence in State or district.

Few of the State constitutions place any limitations on the judiciary, though some contain exceptional provisions. Oregon requires that her judges be citizens, residents of the State for three years and residents of the districts wherein they discharge their official duties. California stipulates that members of the Supreme Court shall be attorneys licensed to practice before the court, while in Colorado and New Mexico the attorney-general must be a lawyer licensed to practise before the Supreme Court. In all States, save those having woman suffrage, the constitutions restrict voting to "male citizens" but many constitutions are silent regarding office-holding and therefore women have gradually established their right to hold elective offices. But this privilege has been denied them in States the constitutions of which expressly provide that elective office-holders must possess the qualifications of electors. Most of the minor State offices are not subjected to constitutional provisions but are regulated by legislative enactment, many of them coming under the civil service laws.

**Bibliography.**—Adams, M. J., 'History of Suffrage in Michigan' (in 'Publications' of Michigan Political Science Association, Vol. III, pp. 1-56, Ann Arbor 1898); Ambler, C. H., 'Disfranchisement in West Virginia' (in *Yale Review*, Vol. XIV, pp. 38-59, 153-180, New Haven 1905); Blackmar, F. W., 'History of Suffrage in Legislation in the United States' (in *Chautauquan*, Vol. XXII [N. S. Vol. XIII], pp. 28-34, Meadville, Pa., 1895); Baldwin, S. E., 'Early History of the Ballot in Connecticut' (New York 1890); Beard, C. A., 'American Government and Politics' (New York 1914); Bassett, J. S., 'Suffrage in the State of North Carolina, 1776-1861' (in 'Annual Report' of the American Historical Association for 1895, pp. 271-285, Washington 1896); Burch, H. R., 'Conditions Affecting Suffrage in Colonies' (in 'Annals of the American Academy of Political and Social Science,' pp. 78-101, Philadelphia 1902); Baker, F. E., 'Brief History of the Elective Franchise in Wisconsin' (in 'Proceedings' of the Wisconsin State Historical Society for 1894, Vol. XLI, pp. 113-130); Bishop, C. F., 'History of Elections in American Colonies' (New York 1893); Beard, C. A., and Beard, M. R., 'American Citizenship' (ib. 1914); Chandler, J. A. C., 'History of Suffrage in Virginia' (in 'Johns Hopkins University Studies in Historical and Political Science,' Ser. XIX, Nos. 6-7, Baltimore 1901); Caffey, F. G., 'Suffrage Limitations at the South' (Boston 1905); Donaldson, W. T., 'Compulsory Voting' (in *National Municipal Review*, Vol. IV, pp. 460-465, Concord, N. H., 1915); DuBois, W. E. B., 'Disfranchisement' (New York 1912); Dougherty, J. H., 'The Electoral System of the United States' (ib. 1906); Fox, D. R., 'The Negro Vote in Old New York' (in *Political Science Quarterly*, Vol. XXXII,

pp. 252-275, Lancaster, Pa., 1917); Guentzer, J. W., 'Citizenship and How to Obtain It' (New York 1901); Hamilton, J. A., 'Negro Suffrage and Congressional Representation' (ib. 1910); Hemphill, J. C., 'The South and the Negro Vote' (in *North American Review*, Vol. CCII, pp. 213-219, New York 1915); Hart, A. B., 'Exercise of the Suffrage' (in *Political Science Quarterly*, Vol. VII, pp. 307-329, 1892), 'Actual Government' (New York 1908), and 'Realities of Negro Suffrage' (in 'Proceedings' of the American Political Science Association for 1905, Vol. II, pp. 149-166, Lancaster, Pa., 1906); Haynes, G. H., 'Representation and Suffrage in Massachusetts, 1620-1691' (in 'J. H. U. Studies,' Ser. XII, Nos. 8-9, Baltimore 1894), and 'Educational Qualifications for the Suffrage in the United States' (in *Political Science Quarterly*, Vol. XIII, pp. 495-513, New York 1898); Jones, C. L., 'Readings on Parties and Elections' (ib. 1912); McMaster, J. B., 'The Acquisition of Political, Social and Industrial Rights of Man in America' (Cleveland 1903); Mechem, F. R., 'Law of Public Offices and Officers' (Chicago 1890); McCrary, G. W., 'American Law of Elections' (ib. 1897); McKinley, A. E., 'Suffrage Franchise in the Thirteen English Colonies in America' (Philadelphia 1905); MacMillan, D. C., 'Elective Franchise in the United States' (New York 1898); Michael, W. H., 'Elections' (in 'Cyclopedia of Law and Procedure,' Vol. XV, pp. 268-465, New York 1905); Munro, W. B., 'Government of American Cities' (New York 1913); Mellor, F. H., 'Legal Qualifications for Office in America, 1619-1899' (in 'Annual Report' of the American Historical Association, 1899, Vol. I, pp. 87-154); McGovney, D. O., 'American Citizenship' (in *Columbia Law Review*, Vol. XI, pp. 231-250, 326-347, New York 1911); Mann, E. C., 'Rights and Duties of Citizens of the United States' (New York 1894); Phillips, J. B., 'Educational Qualifications of Voters' (in 'University of Colorado Studies,' Vol. III, pp. 51-62, Boulder 1906); Remsen, D. S., 'Suffrage and the Ballot' (New York 1892); Rose, J. C., 'Negro Suffrage' (in *American Political Science Review*, Vol. I, pp. 17-43, Baltimore 1906); Steiner, B. C., 'Citizenship and Suffrage in Maryland' (Baltimore 1895); Shepard, W. J., 'Theory of the Nature of Suffrage' (in 'Proceedings' of the American Political Science Association for 1912, pp. 106-136, Baltimore 1913); Smith, W. R., 'Negro Suffrage in the South' (in 'Studies in Southern History and Politics,' New York 1914); Smith, J. A., 'The Spirit of American Government' (ib. 1907); Tucker, H. St. George, 'Womans Suffrage by Constitutional Amendment' (New Haven 1916); Thompson, R. H., 'Suffrage in Mississippi' (in 'Publications' of the Mississippi Historical Society, Vol. I, pp. 25-49, 1898); Van Dyne, F., 'Citizenship of the United States' (Rochester, N. Y., 1904), and 'Treatise on the Law of Naturalization' (Washington 1907); Wise, J. S., 'Treatise on American Citizenship' (Northport, L. I., 1906); Wolfman, N., 'Status of a Foreigner Who Has Declared His Intention of Becoming a Citizen of the United States' (in *American Law Review*, Vol. XLI, pp. 498-514, Saint Louis 1907); Wolfe, A. B., 'Manhood Suffrage in the United States' (Chicago 1913); 'Just a Few Ways in Which the South Will Still

Prevent Negroes from Voting' (in *Everybody's Magazine*, Vol. XXXIII, pp. 251-252, New York 1915). The provisions of the various State constitutions adopted up to 1907 will be found in Thorpe, F. N., 'Federal and State Constitutions, Colonial Charters and Other Organic Laws of the States, Territories and Colonies' (7 vols., Washington, D. C., 1909; issued as 'House Document' 357, 59th Congress, 2d Session). Books relating to woman suffrage will be found under that title. Various phases of the qualifications, rights, powers, duties, liabilities, etc., of public officials will be found in the articles "Officers," "States," "Terr." "Territories," "United States" and the cross-references appended thereto in 'Cyclopedia of Law and Procedure,' Vols. XXIX, pp. 1356-1471; XXXVI, pp. 844-869; XXXVIII, pp. 184-187, 198-208; XXXIX, pp. 693-728. Distinctions between citizenship and suffrage and court decisions regarding these points will be found in the article "Citizens" in 'Corpus Juris,' Vol. XI, p. 774 *et seq.* (New York 1917) and for certain phases of alien citizenship the article "Aliens" in *ibid.*, Vol. II, pp. 1039-1132.

IRVING E. RINES.

**ELECTORAL REFORM.** See ELECTIONS.

**ELECTORAL SYSTEM** of the United States. All elections, whether for city, State or Federal offices, are in all States conducted by ballot. To save the expense of distinct pollings, it has been long usual to take the pollings for a variety of offices at the same time. The details of the procedure previous to, during and after election are thoroughly covered by positive enactments. These deal specifically with registration, the election process, counting of the votes and the various safeguards instituted for the purity of elections.

**Registration.**—Official lists of voters are prepared in advance by registering those eligible to vote. Personal registration, usual in the larger centres of population, requires the personal appearance of the prospective voter at the registration office. Registration by official declaration is common in the less densely populated regions; the local authorities make up the list, but a revision may be demanded by any interested party. A personal identification law is in force in some large cities in order to prevent false registration. Counties and cities are divided into small parts, each with a few hundred votes. The election is controlled by official boards made up of the two parties standing highest at the previous election. The ballot is printed at the public expense and except in Georgia and South Carolina the secret ballot has been adopted. In general the ballot contains the names of all candidates which are placed in party columns, although the Massachusetts ballot includes the names of all candidates under the title of the several offices. The voter on entering the polling office states his name and address, which are entered in the pollbook by a clerk. He is next handed a ballot which is often numbered to correspond with the number on the pollbook, the voter enters the enclosed space provided in the polling place, prepares his ballot, folds it as required by law so that the markings are concealed. He next hands it to the election officer who deposits it in the ballot box. The right of an elector to vote may be challenged for cause, in which case he is put under oath to answer certain questions regard-

ing his qualifications as a voter. When the polls are closed at the legal hour tally sheets are taken up by the election officers. The ballot box is opened and the ballots are withdrawn one by one. The chairman announces the names of the candidates voted for and the officers duly mark their tally sheets. At the close of the count, the results are officially announced. Tally sheets and pollbooks are next sealed and delivered to the custodian designated by law to guard them. The ballots are also sealed and sent to some central authority where they are kept for a certain time in case they may be needed if an election be contested in the courts.

Bribing or bestowing gratuities to influence voters at elections, the acceptance of such gratuities, voting by a person not properly qualified, threats, violence or intimidation of voters, voting more than once, "colonizing," inducing voters to remain away and any other attempt to influence the proper course of an election are severely punished by statute in all the States. Considerable legislation has been enacted in recent years in an effort to control the use of money at elections, many States requiring a sworn statement of all campaign expenses from each and every candidate. See **BALLOT**; **ELECTIONS**; **ELECTORAL QUALIFICATIONS**; **CORRUPT PRACTICES ACTS**; **ELECTORAL FRAUDS**; **VOTE, VOTERS, VOTING**; **WOMAN SUFFRAGE**; **ALIEN**; **CITIZENSHIP**; **CAUCUS**; **CONVENTIONS, POLITICAL**; **INITIATIVE**; **REFERENDUM**; **RECALL**; **PRIMARY**; **VOTING MACHINES**; and consult Beard, C. A., 'American Government and Politics' (New York 1914); Bryce, 'American Commonwealth' (*ib.* 1914); McLaughlin and Hart, 'Cyclopedia of American Government' (*ib.* 1914).

**ELECTORAL VOTES**, the votes cast by the presidential electors or electoral college for President and Vice-President. Prior to 1804 each elector voted for two candidates for President. The one who received the largest number of votes was declared President; and the one receiving the second largest vote was elected Vice-President. The votes for the first President were: George Washington 69; John Adams (Mass.) 34, John Jay (N. Y.) 9, R. H. Harrison (Md.) 6, Jno. Rutledge (S. C.) 6, John Hancock (Mass.) 4, Geo. Clinton (N. Y.) 3, and scattering 7. In 1912 the electoral votes cast by the electoral college were as follows: For President, Woodrow Wilson 435, Theodore Roosevelt 88, William H. Taft 8; for Vice-President, Thomas R. Marshall 435, Hiram Johnson 88, Nicholas M. Butler 8. Consult McClure, 'Our Presidents' (New York 1905); Stanwood, 'History of the Presidency from 1788 to 1897' (Boston 1898); 'History of the Presidency from 1897 to 1912' (*ib.* 1912). See **ELECTORS**; **ELECTORAL COMMISSION**.

**ELECTORS, German Imperial** (Ger. Kurfürst), certain princes of the old Holy Roman Empire who had the right of electing the emperors. The number of the electors was early fixed at seven by the Golden Bull of 1356, including the archbishops of Mainz, Cologne and Trèves, the king of Bohemia, the Count Palatine of the Rhine, the Duke of Saxony, and the Margrave of Brandenburg. An election as king of the Romans was held by the German princes to include the imperial title of Holy Roman emperor, but this was contested by the popes, who claimed the exclusive privilege of

granting the title. In 1648, by the Treaty of Westphalia an electorate was given to Bavaria; and in 1710 to Hanover. In 1802 the Bavarian electorate had expired, the archbishops of Cologne and Trèves were excluded, and the number of electors was increased to 10 by conferring the rank on the rulers of Baden, Württemberg, Hesse-Cassel and Salzburg. In 1806 the emperor gave up the imperial title, and the electors gradually adopted other titles. Consult Bryce, 'The Holy Roman Empire' (London 1892).

**ELECTORS, United States Presidential** (as a body, termed the Electoral College, a term informally used since about 1821, probably suggested by the College of Cardinals; "college of electors" appears in the Act of 1845), the intermediate body for whom, and not directly for President and Vice-President, votes are cast every four years. As originally ordained they were meant to constitute a council of the ablest men in the country, exercising an independent choice of a chief executive. The theory has never been fact for a moment, and since the third election not even a pretense; the institution is retained for very different reasons, and perhaps stronger ones. As a fact, the electors are only registers of the already pronounced party choice in candidates, and accept the office under a tacit pledge to act only as such. The electoral colleges are State bodies, and their integrity as such is scrupulously guarded. They consist of as many members as the State's representation in both houses of Congress; therefore a State cannot have less than three, and New York has 45. The method of appointment is left absolutely to the State legislatures. Till about 1820-24 they were appointed direct by the legislature in most States; in 1824 popular election had superseded this method in all but six, and by 1828 in all but one—South Carolina, which retained it till 1868. The district system, which divides the State's electoral vote, has sometimes been tried as a party compromise; but at present all parties prefer having all the State's electors on a general ticket. Each State appoints the place of meeting of its own electoral college. Congress has fixed the time—the second Monday in January—to prevent a failure of any meeting through the refusal of a minority house of a legislature to join with the majority house in setting a date. The State, by act of 3 Feb. 1887, is made absolute judge of all disputes over appointment or returns; its certificate is decisive between two sets of returns, and Congress can only intervene if the State itself is unable to decide. But what is the State? This was precisely one of the questions before the Electoral Commission (q.v.), and even the new act would seem to leave room for party decision as there; and no Electoral Commission would ever be possible again. In case of vacancy in the electoral body, by death, resignation, refusal to serve or any other cause, the State may pass laws to fill it; if it has no such law, that vote is lost, as happened in Nevada in 1864.

At the meeting of the State electoral college no organization is required; but it is customary to organize and elect a chairman. Separate ballots (which remain the property of the State) are cast for President and Vice-President. In the first three elections, each

simply voted (as required by the Constitution) for two persons, one a resident of a different State, without designating the office; the one with the highest vote became President, the next highest Vice-President. Obviously, as soon as parties gained firm organization, mere party loyalty would invariably produce a tie; and in 1800 Jefferson and Burr were so tied (see *JEFFERSON-BURR IMBROGLIO*), the resulting scandal and danger leading to the 12th Amendment, which obliges the electors to designate the office voted for.

The constitutional provision as amended in 1804 and in force now is as follows:

The electors shall meet in their respective States and vote by ballot for President and Vice President, one of whom at least shall not be an inhabitant of the same State with themselves; they shall name in their ballots the person voted for as President, and in distinct ballots the person voted for as Vice President; and they shall make distinct lists of all persons voted for as President, and of all persons voted for as Vice President, and of the number of votes for each, which list they shall sign and certify, and transmit, sealed, to the seat of the Government of the United States, directed to the President of the Senate; the President of the Senate shall, in the presence of the Senate and House of Representatives, open all the certificates, and the votes shall then be counted; the person having the greatest number of votes for President shall be President, if such number be a majority of the whole number of electors appointed; and if no person have such majority, then from the persons having the highest numbers, not exceeding three, on the list of those voted for as President, the House of Representatives shall choose immediately, by ballot, the President.

"But in choosing the President, the votes shall be taken by States, the representation from each State having one vote; a quorum for this purpose shall consist of a member or members from two-thirds of the States, and a majority of all the States shall be necessary to a choice. And if the House of Representatives shall not choose a President, whenever the right of choice shall devolve upon them, before the 4th day of March next following, then the Vice President shall act as President, as in the case of the death or constitutional disability of the President. The person having the greatest number of votes as Vice President shall be the Vice President, if such number be a majority of the whole number of electors appointed, and if no person have a majority, then from the two highest numbers on the list the Senate shall choose the Vice President; a quorum for the purpose shall consist of two-thirds of the whole number of Senators, and a majority of the whole number shall be necessary to a choice. But no person constitutionally ineligible to the office of President shall be eligible to that of Vice President of the United States."

After voting, they make three lists of the persons, offices and number of votes, and the names of the State electors certified by the "executive authority" of the State; seal them, and certify each; transmit two to the president of the Senate, one by messenger and one by mail, and deposit the third with the Federal judge of the district. They have then no further functions.

On the second Wednesday in February, in the Representatives Hall and in presence of both Houses of Congress assembled, the president of the Senate opens and counts the State returns, and announces the result. In case of a tie the House decides by a majority of States, each having one vote; on a tie for Vice-President, the Senate decides in the same way. If no one candidate has a majority, the Houses decide in the same manner, choosing from the three highest candidates on the list. Thus, in 1824, John Quincy Adams was elected President by the House; in 1837 Richard M. Johnson was elected Vice-President by the Senate. But suppose the third and fourth are ties. This quite probable contingency has not been provided for, and may cause trouble. There was formerly a custom, when a State sent in conflicting electoral returns, of announcing the final result "in the alternative"—so many votes with, so many without, the disputed returns; but the Act of 1887 ends this, and it was always unworkable where the disputed votes were vital to the election. By the 22d Joint Rule of Congress up to 1876, in case of dispute the returns from that State were thrown out, but in anticipation of the struggle over the returning boards, the Republican Senate on 20 Jan. 1876 repealed the rule.

In order to obtain the electoral votes of a State, a party must carry the State. In other words, the electoral vote of a State is determined by the highest popular vote cast in that State. The popular vote for electors is counted, but there is no electoral vote to count unless a State is carried. Consequently, the smaller parties which have not had a large enough popular vote to carry a State have not had the State votes in the electoral college, and must therefore be counted by popular vote only, having no representation in the electoral college at all.

The electoral system, despite its wide divergence from the intent of its originators, and its undeniably undemocratic character, is never seriously menaced, because of its practical utility in settling the presidential question at once on the counting of State votes. With direct popular vote, where parties are closely balanced, the result could not be known perhaps for months.

In accordance with the Reapportionment Act of 1911 the number of electors in the several State colleges is as follows:

Alabama.....	12	Nebraska.....	8
Arizona.....	3	Nevada.....	3
Arkansas.....	9	New Hampshire.....	4
California.....	13	New Jersey.....	14
Colorado.....	6	New Mexico.....	3
Connecticut.....	7	New York.....	45
Delaware.....	3	North Carolina.....	12
Florida.....	6	North Dakota.....	5
Georgia.....	14	Ohio.....	24
Idaho.....	4	Oklahoma.....	10
Illinois.....	29	Oregon.....	5
Indiana.....	15	Pennsylvania.....	38
Iowa.....	13	Rhode Island.....	5
Kansas.....	10	South Carolina.....	9
Kentucky.....	13	South Dakota.....	5
Louisiana.....	10	Tennessee.....	12
Maine.....	6	Texas.....	20
Maryland.....	8	Utah.....	4
Massachusetts.....	18	Vermont.....	4
Michigan.....	15	Virginia.....	12
Minnesota.....	12	Washington.....	7
Mississippi.....	10	West Virginia.....	8
Missouri.....	18	Wisconsin.....	13
Montana.....	4	Wyoming.....	3

The whole number of electors in the United States, until another reapportionment is made, will remain at 531, and the majority necessary to secure an election to the presidency will be 266. See APPORTIONMENT.

Consult Dougherty, J. H., 'Electoral System of the United States' (1906).

**ELECTRA**, in Greek legend, the name of several personages. (1) One of the Oceanides, wife of Atlas, and mother of Dardanus by Zeus. (2) A daughter of Atlas and Pleione, who became one of the Pleiades. (3) A daughter of Agamemnon, king of Argos, who incited her brother Orestes to avenge their father's death by killing their mother, Clytemnestra. Orestes gave her in marriage to his friend, Pylades, and she became the mother of Strophius and Medon. She is the subject of a number of dramas, both ancient and modern.

**ELECTRA**. Benito Pérez Galdós' drama 'Electra,' one of the most conspicuously successful, as well as one of the shortest-lived of modern Spanish plays, was performed for the first time in the face of violent protest at the Teatro Español, Madrid, in 1901. Constructed with the author's customary skill, it is written in a spirit of broad tolerance, the didactic touch never being entirely absent from its pages. Yet as a thesis drama the play is unconvincing. In particular, the solution of the conflict between the scientific spirit and the Church, typified in their struggle for the soul of a young woman, is precipitated at the dénouement by means of an apparition which effects a reconciliation between the demands of science and religion through supernatural aid. Undoubtedly this evasion was not without utilitarian justification, and made the performance of the play possible. Galdós had been associated for many years with a program of social, political and literary reform, which had brought to his aid a host of admirers, among whom the great body of the more intelligent of the youth of his country was included. In 'Electra,' he turned to attack directly the forces of conservatism and reaction, and in the sharpness of the issue then joined lies the chief significance of the play. With its production the influence of the author reached its zenith, and his victory assured the succeeding generation that freedom of expression which was essential to the development of modern Spanish letters.

An English translation was published at Chicago, 1911. Authoritative criticism of Galdós may be found in Alas, L., 'Galdós' (Madrid 1912) also Martínez Ruiz, J. (Azorin), 'Lecturas españolas' (Madrid 1812).

JOHN GARRETT UNDERHILL.

**ELECTRA**. Although Hugo von Hofmannsthal possesses no original genius, he is the most musical of poets who in recent times have contributed to the drama in German. His power of verbal expression, rather than his dramaturgic skill or his understanding of character, entitles him to praise. A Viennese, he is an æsthetic cosmopolite. In 'Venice Preserved' he has reworked the English tragedy of Otway and in 'Electra' and 'Œdipus and the Sphinx' the Greek tragedies of Sophocles, embroidering his models with fresh details and intensifying passion. His reversion to the Greek was inspired by the presentation at the

Burg Theatre in Vienna of Æschylus, translated into German by Wilamowitz-Mollendorff, and by the suggestion of the critic Paul Schlenker that modern playwrights should render classic themes in a free fashion. 'Electra' appeared in 1903; and in 1908, in the version of Arthur Symons, it was played in English with Mrs. Patrick Campbell in the title rôle. It has also served as the libretto for an opera by Richard Strauss.

The piece is in one act and dispenses with the classic chorus, partly because this would be counter to our stage conventions, and partly because it would detract from the lyrical fervor of the individual characters. The Sophoclean story of Electra's yearning for the return of her brother Orestes to whom she may confide the task of avenging her mother's murder of her father is repeated, with the weakness of her sister Chrysothemis, the appearance of Orestes as a messenger come to announce his own death, and his slaying of his mother, Clytemnestra, and her paramour, Ægisthus. Von Hofmannsthal, however, has made no effort to achieve the noble dignity of the Greek. Instead, he has sensualized Electra, whose lust for vengeance on her guilty mother becomes hysterical and insane. Hatred, she says, has been her bridegroom; curses and despair have been her children. When Orestes finally slays his victims, Electra dances in very ecstasy of joy. As an American critic, Mr. W. P. Eaton, has remarked: "Pity and fear are not aroused by von Hofmannsthal's play, but curiosity and horror. The emotions are not purged, but scraped, irritated, made to shiver and creep." The best account of von Hofmannsthal is Dr. August Köllmann's monograph in German (1907); he is discussed in English by Elizabeth Walter in 'Poet Lore' (1915), and by Ashley Dukes in 'Modern Dramatists' (1912).

FRANK W. CHANDLER.

**ELECTRIC ALTERNATING CURRENT MACHINERY.** A loop of wire revolving in a magnetic field is the simplest form of an alternating current generator. The direction of induced electromotive force in the two halves of the loop, which cut the magnetic flux in opposite directions, is such that the combined electromotive force at the terminals is double that of either revolving conductor alone. This induced electromotive force is proportional to the rate of cutting the magnetic lines, and therefore to the sine of the angle by which the plane of the coil differs from the plane midway between the poles and normal to the magnetic flux. At its zero position, or when the planes coincide, the coil is cutting no lines of force and we have  $\sin a = 0$ . The electromotive force, however, grows as we depart from this zero position, assuming uniform speed, until, when 90 degrees is reached the rate of cutting of the lines becomes a maximum,  $\sin 90 \text{ degrees} = 1$ . Passing on, the electromotive force dies away until 180 degrees is reached, when the value again is zero. From this to 270 degrees we have an increasing electromotive force, but of opposite polarity and at the end of the revolution, or 360 degrees, again reach zero. Thus we have in one revolution in a two-pole field two waves of pressure of the same form but of opposite sign. The one is called the positive wave and the other the negative. One such

revolution, or one positive wave and one negative wave, constitute what is called a cycle, or period, which in technical literature is designated by the symbol  $\sim$  = one sine wave. The great majority of systems have a frequency between 60  $\sim$  and 25  $\sim$ . Both of these frequencies are standard practice in this country, and the values between are chosen for special cases. Owing to the high frequency of commercial systems, alternators are built with more than one pair of poles, in order to keep the revolving speed within reasonable limits.

**Average and Effective Values.**—If we plot the values of the instantaneous pressures as ordinates, with time as abscissa, we have a correct representation of the generation of alternating currents, and the shape of the wave. When the total number of lines cut per revolution by a coil revolving at constant speed remains the same, the average induced electromotive force remains constant, regardless of the distribution of the magnetic flux. The effective value, however—the value read by the metre and the value which corresponds in its heating effect to the direct current value—is not independent of this distribution.

**The Place of Alternating Current Systems.**—The direct current for the railway at 550 volts, and for the lighting and power systems of the densely populated centres of our large cities in the Edison three-wire system 110 to 220 volts, seems to have become standard practice. Nevertheless the low radius of distribution without excessive cost of copper, even in the 550-volt railway system with a grounded return, makes necessary a great multiplicity of moderate-sized or small plants, operating at low efficiency. It is here that the alternating current comes to the front. While commutators (q.v.) can be built for collecting direct current for 1,000 volts, alternators can be built for 12,000 volts and step-up transformers of high economy are quite possible at 75,000 to 100,000 volts. Remembering that the copper cost is inversely as the square of the voltage, the great possibilities of the alternating current system are at once seen.

**Energy from Waterfalls.**—Electrical energy from waterfalls that a few years ago were merely points of scenic interest is now supplied to hundreds of cities in North America. There are numerous power plants of from 50,000 to 200,000 horse-power capacity, sending currents with voltage from 25,000 to 150,000 to distances up to 250 miles. See HYDRO-ELECTRIC DEVELOPMENT and ELECTRIC TRANSMISSION OF ENERGY.

**The Alternator.**—Small alternators and those of moderate potential usually collect their current from insulated rings mounted on the shaft and connected to the ends of the armature winding. Through brushes, the current is taken to the external circuit. In some machines a rectifier is added for supplying sufficient undimensional current to produce the necessary additional field to overcome the drop due to increase of load. All commercial alternators are supplied with an exciter, or direct current dynamo, whose function is to supply current to the field windings. The field spools are usually connected in series. The amount of current thus necessary on a full non-inductive load varies from 1½ to 3 per cent of the total output of the alternator. Owing to the difficulty of collecting



# ELECTRIC ALTERNATING CURRENT MACHINERY

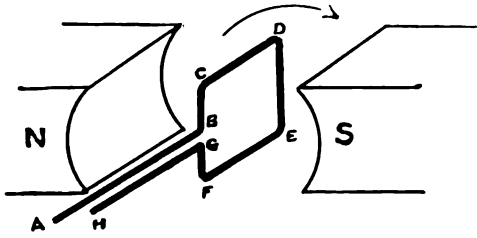

Fig. 1 Diagram of simple alternating current generator. N S poles of magnet. A B C D E F G H loop of wire

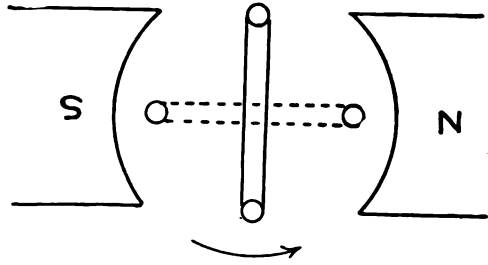

Fig. 2 Diagram of simple two-phase alternator

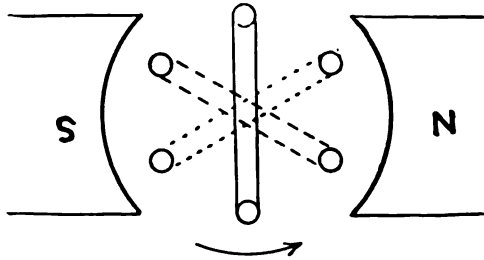

Fig. 3 Diagram of simple three-phase alternator

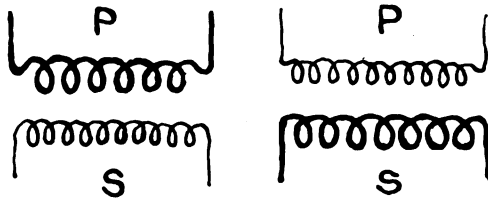

Fig. 4 Diagram showing step-up (left) and step-down (right) transformers. P P primary coils; S S secondary coils

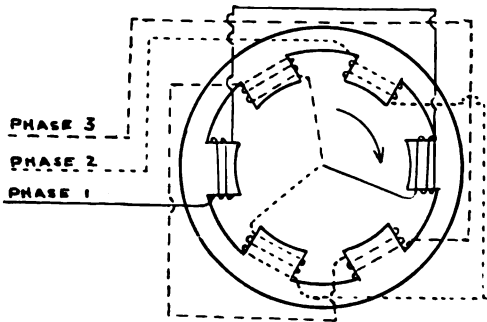

Fig. 5 Diagram showing winding of a two-pole, three-phase rotating motor field

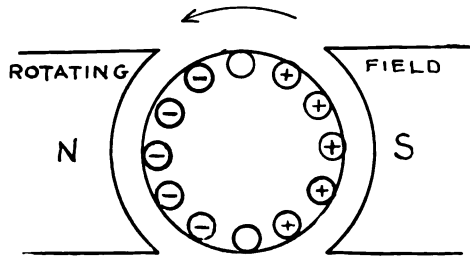

Fig. 6 Diagram showing "signs" of rotor bars if there were no inductance

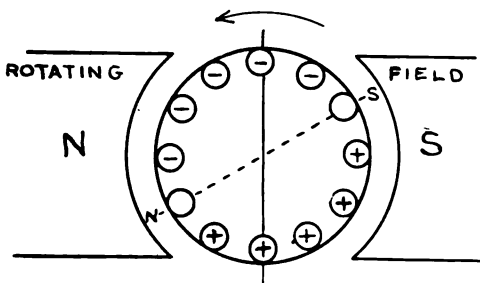

Fig. 7 Diagram showing "signs" of rotor bars under the influence of inductance

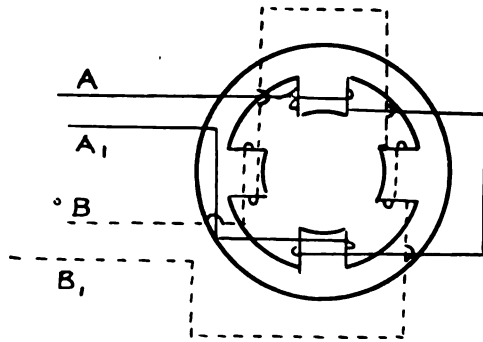

Fig. 8 Diagram showing winding of two-pole two-phase rotating motor field. A, is the return wire of phase A, and B, the return wire of phase B



large currents by means of brushes and of preserving good insulation between the rings and shaft, the revolving field type of machine is now used in almost all large installations, the field current from the exciter being supplied through cast-iron rings mounted on the shaft, or in the case of the inductor type, consisting of an annular ring surrounding the inductor or revolving element, which consists of laminated iron poles suitably spaced and keyed to the shaft. The windings being stationary, there are no moving connections, either for the field current or the main current of the machine. In either type the alternating current is taken from the terminals of the windings, usually at the bottom of the frame.

**Polyphase Machines.**—If two armatures, of the same number of turns each, be connected to the shaft at 90 degrees from each other, and revolved in a bi-polar field, and each terminal be joined to a collector ring, we have two separate electromotive forces differing in phase by 90 degrees or a two-phase machine. With 120 degrees phase difference and three sets of armatures we have a three-phase winding. By properly interconnecting the three circuits, we may use but three wires for transmission, or four, in accordance with the system used. The construction of multiphase machines is similar to that of the single-phase type, excepting that in the former we have as many armatures, series connected, as there are phases.

In the two-phase three-wire system, the wire from the common junctions of the phases carries 1.414 times the current of the outer wires. The electromotive force between the outer wires is also  $\sqrt{2} E$ , when  $E$  is the electromotive force per phase, or between either outer wire and the common return. When this system is used it is important that the load be carefully balanced on the phases and that the power factor be kept as high as possible in order to keep the voltage on the phases nearly alike at the receiving end. Single phase motors or lamps may be connected to either or both phases, but it is very important that no load be connected between the outer-wires, as the effect is to badly unbalance the voltages on the different phases.

In the three-phase star connected system the line voltage is  $\sqrt{3}=1.732$  times the voltage on the coils of the machine, or the machine voltage, which is the pressure between any one of the three line connections and the common neutral. The line current in this system is the current that flows through any one of the machine windings. In the delta connection, the line voltage is the same as the voltage across any phase of the machine, while the line current, being the resultant of two currents, is  $\sqrt{3}=1.732$  times the current flowing through any phase of the machine.

**Energy Polyphase.**—In a two-phase circuit, whether three or four wire, the energy flowing is the sum of the products of each phase current by the phase pressure. Two wattmeters are used. In the three-phase system when  $E$ =volts between lines;  $I$ =amperes on lines;  $W$ =total watts output of machine,—then, whether the connection be star or delta, the total

output is  $\frac{3E \times I}{\sqrt{3}} = 1.732 EI$ , always supposing the system be balanced. Thus the output of the

machine is not changed by changing the connections from star to delta. In the balanced three-phase system, one wattmeter will register the total output if its constant be multiplied by 1.732. Two wattmeters are usually employed.

**Regulation of Alternators.**—The regulation of modern alternators varies from 5 to 6 per cent, which means that in case the full, non-inductive load of an alternator be taken off, the speed and excitation being kept constant, the terminal pressure will rise by an amount corresponding to from 5 per cent to 6 per cent of its full load voltage. Close regulation means a much better voltage-regulation on the system and stronger synchronizing power. A certain amount of armature reaction is necessary to avoid large cross currents on changing the field of one or more machines operating in parallel, in the attempt to preserve the same terminal voltage. The efficiency of large alternators is about 96 per cent to 97 per cent.

**Frequency.**—In regard to the frequency best adapted to transmission work, or to local distribution, various factors enter into the problem. At 60  $\sim$  both arc and incandescent lamps can be operated satisfactorily. The transformers are smaller and cheaper than at 25  $\sim$  and motors are very satisfactory both as to low first cost, range of speed, and good starting torque (q.v.). Frequencies over 60  $\sim$  have been abandoned. The line drop, due to reaction, increases with the frequency: a change of frequency from 25  $\sim$  to 125  $\sim$  would, on the same line, more than double the line drop. While as a rule 60  $\sim$  apparatus is cheaper than that for 25  $\sim$  yet the increase in polar speed often becomes difficult without increasing the number of poles to an undesirable extent, which, in 60  $\sim$  apparatus, may be sufficient to make the parallel operation of low speed direct-connected alternators quite difficult.

**Self-induction.**—When a current is introduced into a circuit a magnetic field is produced, surrounding the conductor, the rise of which causes a counter electromotive force. This electromotive force is called the electromotive force of self-induction. The effect of self-induction upon electric currents is directly comparable to the effect of inertia on a material body. It is that quality that tends to hinder the introduction, variation or extinction of the current in a circuit. As this effect is greatest at times of most rapid change of magnetism set up by the current, in alternating current circuits, it becomes a maximum when the inducing current is passing through zero, and, therefore, the counter electromotive force of self-induction lags 90 degrees behind the current in the circuit. It also follows the sine curve provided the current flowing is sinusoidal.

In a circuit containing several impedances in series, the joint impedance is not the sum of the individual impedances, but is obtained by taking the square root of the total added reactances squared plus the total added resistances, squared. That is, Impedance =

$$\sqrt{(R_1 + R_2 + R_3)^2 + (2\pi f l_1 + 2\pi f l_2 + 2\pi f l_3)^2}$$

The joint impedance of several impedances in parallel is found as follows. Construct a parallelogram from the reciprocals of two of the impedances, each expressed in its proper phase relation. The direction of the diagonal will give the phase of the resultant im-

pedance and its reciprocal amount will give the reciprocal of its length. For more than two, the method of the polygon of forces is applied. The effect of self-induction varies with the frequency of the current supplied, and as the square of the number of turns in a circuit. The self-induction in the armature of an alternator has two effects. The first is to produce a lagging current and thus lower the terminal voltage, and the second is a demagnetizing effect. The current is thrown into such a phase that it produces lines of force directly opposed to the field and thus lowers the voltage by reducing the total flux. The effect of armature reaction depends upon whether the current is leading or lagging in phase. A lagging current lowers the voltage of an alternator and a leading current raises it.

**Capacity.**—All insulated conductors have the quality of being able to hold, stored on their surfaces, a certain quantity of static electricity, and are thus condensers. The charging and discharging of an alternating current circuit causes the current to flow from the generator into the line and then back into the generator again, with the frequency of the alternator, in order to keep up the static potential on the line. As this charging current is greatest when the rate of change of electromotive force is greatest, a sinusoidal wave of capacity electromotive force with 90 degrees difference in phase from the machine electromotive force is produced. This leads the active electromotive force by 90 degrees and is thus directly opposite to the electromotive force of self-induction. If we have a circuit in which the electromotive force of self-induction is just equal to the capacity electromotive force, and these two parts of the circuit are in series, the effect of both is neutralized and we have, as in direct currents,  $W=EXC$ .

**The Transformer.**—The one piece of apparatus that more than all else has made possible the electrical transmission of energy to long distances is the transformer. This is the apparatus that receives in one set of coils the dangerous potential of the line and transforms it into whatever potential is desired for lights or motors, which are supplied from an entirely separate winding. The transformer consists of a magnetic circuit of laminated iron or mild steel interlinked with two electric circuits, one, the primary, receiving electrical energy and the other, the secondary, delivering it to the consumer. The effect of the iron is to make as many as possible of the lines of force set up by the primary current cut the secondary winding and there give rise to an electromotive force of the same frequency, but different voltage.

Not only does the transformer make possible the transformation of voltages, but it also permits of changing from one system to another. Thus a single-phase primary may supply a three-wire Edison system, of course, with alternating current. A two-phase system can be changed to a three-phase or vice versa; a four-wire two-phase may make a three-wire two-phase, and many other useful combinations may be effected. The Scott connection for changing two-phase to three-phase, or the opposite, uses but two transformers. One has a ratio of, say 10 to 1, with a tap at the middle

of its secondary coil. The other must then have a ratio of 10 to  $.866 = 10$  to  $\sqrt{\frac{3}{4}}$ . One terminal of the secondary of this transformer is connected to the middle of the other secondary, and the remaining free ends of both secondaries form the three terminals of a three-phase circuit. The value  $\sqrt{\frac{3}{4}}$  is the altitude of an equilateral triangle of which the base is unity, and thus we may consider the current to be taken from the corners of an equilateral triangle, which represent, in phase and potential difference, a true three-phase system. The current in the transformer of secondary, 866 being the resultant of the other two-phases, is greater than under normal two-phase conditions; and, therefore, the windings must have about 15 per cent more copper. If two similar transformers are used the secondary of each has taps giving 50 per cent and 86.7 per cent of full voltage. In many large installations, notably at Niagara Falls, we find two-phase generators feeding three-phase lines through Scott connected step-up transformers. In small systems standard transformers may be used having ratios of 10 to 1 and 9 to 1 respectively, and the results will be quite satisfactory.

**The Induction Motor.**—Acting upon the well-known fact that a copper disc could be made to revolve by rotating a horseshoe magnet so that the lines of force cut the disc, Ferraris, Tesla, Dobrowolsky and others have developed the present type of induction motor. The credit for the first commercial application of the rotating field caused by currents of displaced phase probably belongs to Tesla. At the present day the value of these discoveries in the transmission and distribution of power can hardly be estimated. The induction motor is somewhat similar to the direct-current shunt motor. Both motors have field and armature windings. In both cases, also, the field is connected directly across the mains. In the shunt motor the armature current is supplied through brushes and a commutator to the windings, while in the induction motor the armature current is an indirect current, the field acting as the primary of a transformer of which the armature is the secondary. In both motors the efficiency is inversely proportional to the armature resistance, as is also the speed regulation of the motors. The less the armature resistance the higher the efficiency and the closer the regulation of speed between no load and full load. In practice, either element may be the one to revolve. The rotation is produced by the reaction of the armature, or indirect current, on the revolving magnetic field, which results in dragging the moving element around in order to keep up with the field flux, as it passes around the face of the primary windings. This field, being the resultant of two or more alternating fields of different phases, rotates with the polar frequency of the supplied voltage. The secondary winding is made up of copper bars set in slots in a laminated iron core and running across the armature parallel with the axis of rotation. This separating of the old copper disc into narrow bars constrains the current to flow into the best direction for producing torque and avoids the waste of the unconstrained Foucault currents in the Arago disc, and thus makes the motor much more

efficient. Sometimes the secondary windings are joined to heavy short-circuiting rings at both ends, resulting in the squirrel-cage type of motor; and in other cases the secondary windings are taken out through collector rings, if the secondary be the rotating element, and starting resistances are inserted in series to lessen the reaction due to excessive starting current and thus improve the starting torque. When up to speed these resistances are cut out and the terminals short-circuited as in the squirrel-cage type.

**The Asynchronous Generator.**—If the motor be driven by power from an outside source up to true synchronism, no current will flow in the secondary, and the primary current or field current will be wholly made up of the wattless exciting current, just as in a transformer at no load. The slip, or amount by which the motor speed at full load differs from synchronous speed, may be as little as 2 to 2½ per cent of the speed of synchronism in large motors, and in small motors may be 5 per cent or more. If the motor above mentioned be forced above synchronism the motor becomes a generator, provided the connection to the mains is left closed, and when a negative slip of the same amount as full load slip as a motor is reached, the generator will be giving out its full output at the same frequency as the exciting circuit. The possibilities of this system are interesting.

**The Synchronous Motor.**—The synchronous motor is merely an alternating current generator of special design. Both motors and alternators have a direct current field and an alternating current armature. The operation of a synchronous motor, when once brought up to speed and thrown into circuit, is the same as that of an alternator in parallel with one or more alternators. When the back pressure of the motor is equal and directly opposed to that of the line no current can flow. The friction, however, causes the revolving element to lag slightly behind the line pressure, and a current is driven through the motor by the generator. This current increases directly with the lag behind the central-phase position caused by increased load. A good synchronous motor, while always revolving at the same polar speed as the alternator supplying the line current, will carry a load of five or six times full load before it breaks out of step, and becomes practically a short circuit on the system. The current which passes through such a motor on short circuit, while held down by the inductance of the windings, is yet sufficient to rapidly damage the insulation if not cut off. The great advantage of the synchronous over the induction type of motor is that the power factor can be raised or lowered at will. By raising the field strength of a synchronous motor the current taken by the motor may be made leading and hence help keep up the line voltage on a heavy inductive load. This is of the greatest importance in practice. It is good practice to set the field strength for a good power factor at full load. At light loads the motor is assisting the generator to maintain the required pressure. Another advantage of the synchronous motor is that it can easily be built for very high voltage, especially the revolving field type—a 12,000 volt motor is not at all unusual

practice—thus the use of transformers may be dispensed with.

**The Rotary Converter.**—The rotary converter is a specially designed direct-current generator provided, at proper points in the winding, with taps to collector rings, from which, if the machine is run as a motor from the direct-current side, an alternating current may be taken. Usually the alternating current is taken from the secondaries of suitable transformers and supplied to the rings, driving the rotary as a synchronous motor, the direct current being taken from the brushes on the commutator. As the reaction of the incoming alternating current about balances that caused by the outgoing direct current, the armature reaction of such a machine is very small and the brushes can be always kept in one fixed position. If the taps from the armature are taken off at points differing 180 degrees from each other, electrically, we have a single-phase rotary. If connections are made 90 degrees apart we have a two-phase rotary, using four collector rings. Taking 120 degrees around the armature for our taps we have a three-phase rotary, using three collector rings. By adding to the number of taps and therefore to the number of rings we may have a six-phase rotary. The output of a rotary is greater than its output as a direct-current generator, chiefly on account of the absence of armature reaction and because at certain positions the current flows straight from collector ring to commutator and thus avoids the loss due to heating. The rotary converter, with its step-down transformer, is the most efficient means we now have of transforming the high tension polyphase currents of our large central stations to direct current for the Edison system, and for railway purposes. This piece of apparatus is wound either shunt or compound, in accordance with the use for which it is intended. As in the case of the synchronous motor, the rotary is a valuable help to the central station by running at a very high power factor. By overexciting the fields the current taken by the rotary becomes leading and helps to hold up the voltage of the central station in case of a heavy load of induction motors by means of the armature reaction of the generators. Owing to very high commutator speeds at the higher frequencies, rotaries are not much used on frequencies above 60 degrees. At this frequency they operate satisfactorily. At lower frequencies, however, rotaries are at their best, and will stand enormous overloads, sudden changes in load and other disturbances, with perfect satisfaction. The voltage of the direct current end of a rotary is that of the peak of the sine wave of the alternating pressure, and thus a voltmeter across the collector rings would read  $\frac{E}{\sqrt{2}}$  where

$E$  is the direct-current electromotive force in single and two-phase rotaries. In the three-phase system the ratio between the alternating current pressure and the direct current at the commutator brushes is  $\frac{\sqrt{3}}{2\sqrt{2}} = .612$ . Thus in the

Edison system operating at 250 volts we should have to transform down to  $250 \times .612 = 153$  volts at the secondary of the transformers. While rotaries can be started up without field, from

the alternating current side, it is not good practice, excepting in certain special cases. Generally they are started up exactly like a shunt motor, synchronized, and then thrown upon the alternating current line. When a rotary is started up from the alternating current side, on closing the field switch it is impossible to tell what the polarity will be. Rotaries operate in parallel with perfect satisfaction, as a rule, on both the alternating current and the direct sides. The storage battery is always used in a large rotary installation to ensure against any possible contingencies. On compound rotaries the equalizer must be used, just as in the case of direct-current compound generators. See **ELECTRIC MACHINE**.

A. R. CHEYNEY,  
*Station Superintendent Philadelphia Electrical Company.*

**ELECTRIC ANNEALING**, a process of annealing by the heat generated by the passage of an electric current through the body to be annealed, or in which heat generated by an electric current is used in place of ordinary heat. The heat developed in a conductor by an electric current is equal to the product of the square of the current by the resistance of the conductor= $C^2R$ . An interesting experiment showing the fusing power of the electric current is made in the following manner: Provide a glass or porcelain vessel containing a mixture of sulphuric acid and water. Introduce a lead plate electrode suitably connected with the positive pole of a continuous-current generator. Connect by a flexible wire the negative pole to a stout pair of metal pliers. When, by means of the pliers, a metal rod is immersed in the acid solution, the liquid is seen to boil near the rod, which is brought to a dazzling whiteness in a few moments, and presently begins to melt. The heating is so quickly produced that the liquid or the body of the rod has not time to become hot. In a short time a temperature of 7,000° F. may be developed, and with a very strong current a temperature of 14,000° F. has been produced.

**ELECTRIC ANNUNCIATOR**, a form of annunciator used in private houses, offices and hotels. They are used to call messengers, to announce an alarm and to indicate the source of the alarm in connection with electric burglar-alarm apparatus, and for numerous other purposes. In some forms of annunciator the source of the call is indicated by the movement of a needle on the face of the case opposite a given number; in others a shutter drops, disclosing the number or name of the room or office. See **ELECTRIC SIGNALING**.

**ELECTRIC ARC**, the intensely hot bright flame that forms where an electric current jumps a gap between two electrodes: called also voltaic arc. It tends to curve in an arc following the lines of force, hence the name. This is the source of light in an arc lamp. (See **ELECTRIC LIGHTING**). The lamp carbons, which constitute the electrodes, are usually enclosed to retain the carbon vapors. The carbons have to be set at a slight distance apart, and as they burn down require to be moved so as to maintain the correct distance for permitting a good arc. In burning, the carbons create carbon vapor, which is a conductor, and the

current flows along this vapor conductor in an arc of visible flame. If the electrodes are impregnated with metallic salts and a powerful current passed across the gap, the so-called "flaming arc" results, of varying color, according to the salts employed. Vacuum tube lighting is also accomplished in a somewhat similar principle. See **ELECTRIC LIGHTING** and **ELECTRIC FURNACES—Arc Furnace**.

**ELECTRIC AURA**, a current or breeze of electrified air employed as a mild stimulant in electrifying delicate parts, as the eye.

**ELECTRIC AUTOMATIC FIRE-ALARM**. See **ELECTRIC SIGNALING**.

**ELECTRIC BALANCE**, an instrument for measuring the attractive or repulsive forces of electrified bodies; a form of electrometer, consisting of a graduated arc supported by a projecting plate of brass which is attached to a perpendicular column. A wheel, the axis of which is supported on anti-friction rollers, and is concentric with that of the graduated arc, carries an index. Over this wheel, in a groove on its circumference, passes a line, to one end of which is attached a light ball of gilt wood, and to the other a float, which consists of a glass tube about one-fifth of an inch in diameter, terminating in a small bulb, so weighted that the index may point to the centre of the graduated arc. The difference between the weights of the float when in and out of water is known, and the diameter of the wheel carrying the index is such that a certain amount of rise or fall of the float causes the index to move over a certain number of graduations on the arc. See **ELECTROMETER**.

**ELECTRIC BATH**, a solution in a vat or tank containing a salt of some metal, as copper, silver, gold, etc., and connected with the negative pole of a battery or dynamo. A current being passed through, the metallic salt is deposited on the negative pole, or more strictly speaking, on the object to be plated, connected with the pole. The process is called electro-deposition. (See **ELECTRO-PLATING**; **ELECTRO-CHEMISTRY**). The name electric bath is also sometimes applied to a hot water bath through which a weak electric current is sent, for the treatment of patients. Its therapeutic value is questioned by many.

**ELECTRIC BATTERIES**. The electric battery is a device by which electric energy is derived directly from chemical action. There are two types of electric batteries: (1) primary, and (2) secondary. Secondary batteries are usually called "storage batteries" or "accumulators" and are discussed in another article.

The battery unit is called a "cell." The simple primary cell, or Voltaic cell, as it is often called, from its inventor, Volta, consists of two different metals immersed in a weak water solution of some acid which will act with unequal intensity upon the two metals. The greater this inequality of action, the larger will be the difference of electric potential between the two metals; and, as the current excited in the cell depends upon this difference of potential, the greater will be the strength of the current. The two metals form the electrodes of the battery cell, and the solution is the electrolyte.

The chemistry of the primary cell is thus

explained: When a piece of metallic zinc is placed in sulphuric acid diluted with water, a chemical union takes place, the acid and the zinc combining to form the new substance, zinc sulphate. In order that this may be brought about a certain amount of oxygen must be obtained to complete the combination, and as neither the acid nor the zinc can supply it, it is taken from the water lying next to the zinc, and which is thus decomposed—the hydrogen formerly in combination with the oxygen being set free in little bubbles which cling to the zinc. These bubbles eventually cover the zinc and slow down the formation of zinc sulphate until it nearly ceases. If now a strip of copper be placed in the same vessel, but not in contact with the zinc, the conditions remain as they were; but if the ends of the pieces of zinc and copper above the level of the water are leaned together so as to touch above the water, the chemical action is vigorously renewed, but the hydrogen bubbles now appear on the copper. The action of the acid upon the zinc so reduces its electric potential that when contact is made with the copper an electric current immediately moves to restore the electrical equilibrium. This being restored, the chemical action—the formation of zinc sulphate—is free to go on, and thus the cycle continues until the zinc has been entirely transformed into sulphate. And all the time the action is proceeding the electric current is continually flowing to preserve the equilibrium. If, instead of tipping the two metals in the cell until they touch, a metallic conductor is placed so that one end touches the zinc and the other the copper, the current will traverse the whole length of the conductor; and this conductor may be cut and a machine inserted, so that the passing current may be made to expend part of its energy in work. The current is observed to flow from the zinc anode to the copper cathode within the battery. Outside of the battery the current flows through the conductor from the copper toward the zinc. From this external movement the copper has received the title of the positive pole and the zinc of the negative pole.

The force or pressure which causes the current to flow is called the electromotive force (commonly abbreviated to E.M.F.). It should be understood that the words "current" and "flow" are not used in the same sense as with a liquid like water. A better understanding is obtained from the illustration of a steam boiler carrying a high pressure of steam. When a valve into an empty pipe is opened, the pressure of steam in the boiler is transmitted to the further end of the pipe. In this case the steam fills the pipe carrying the pressure with it. In the case of the electric current passing along a conductor only the pressure (E.M.F.) is transmitted, there being no flow of any known material substance.

The electromotive force of a cell is dependent to a large degree upon the kind of acid used to dissolve the zinc. When the two plates are immersed in other acids than sulphuric, a considerable variation is found in the difference of electric potential set up in the cell, and it is to be borne in mind that it is upon this *difference* that the strength of the current depends. The electric energy produced or released by a cell depends on the number of pounds of zinc

and acid consumed in the formation of zinc sulphate. The zinc is the battery fuel and is oxidized just as coal is oxidized in a furnace. The sulphuric acid does not dissolve the zinc itself, but dissolves the oxide as fast as it forms, thus making the action of the cell continuous.

If a simple cell is put in circuit with a galvanometer, it is observed that the current gradually diminishes in strength, due to the film of hydrogen bubbles which adhere to the copper. This condition is called "polarization." If the bubbles are brushed away, the current resumes (nearly) its former strength. It becomes necessary then to establish some mechanical means of removing the hydrogen or to use some chemical substance in the cell which will combine with it and so remove it as fast as it forms. Mercuric chloride is sometimes used for this purpose. In the bichromate cell the oxygen of the bichromate seizes upon the hydrogen and combines with it to form water. In the Leclanché cell the depolarizer is manganese dioxide. Another method of avoiding polarization is a cell construction which admits of using two separate liquids, the metal on which the hydrogen collects being placed in a solution of some chemical which combines with the hydrogen as it forms.

Another phenomenon which affects the strength of current passing through a cell and thence through the conductor which connects the two dry poles of the battery is what is called "resistance." This is of two kinds or divisions: internal and external. The former is that within the cell itself—the metals and the liquids; the latter in the outside conductor. If this conductor is of some substance which has a low degree of electric conductivity, like lead; or even if of high conductivity, like copper, but is very long, or of very small circumference, or both, the electric current will move along it very sluggishly, as if being held back by some obstacle—a resistance. This has the effect of slowing down the chemical action in the cell, and the result is what is termed a "weak current." With a short and comparatively large conductor of a high degree of conductivity the external resistance is reduced to a minimum. The internal resistance of a cell is increased by polarization, as already mentioned, and this is remedied by using a depolarizer. The internal resistance may also be further reduced by giving the metallic components large areas and placing them quite close together, making the travel of the current through the electrolyte as short as possible.

Primary electric batteries are classified as wet batteries and dry batteries. In the first group liquids are used as electrolytes; in the second, chemicals which retain moisture for a long time take the place of electrolytes.

#### WET BATTERIES.

Wet batteries are divided into one-liquid batteries and two-liquid batteries. The former are those which contain one homogeneous electrolyte; the latter have two distinct electrolytes, and the cell is usually divided into two parts by a porous cup which contains one of the metallic electrodes and one of the electrolytes.

**One-Liquid Batteries.**—Among the principal one-liquid batteries now in use for

economic purposes and in general laboratory work are the following:

*Smee.*—A cell consisting of a platinum plate hung between two zinc plates in an electrolyte of dilute sulphuric acid. The platinum plate is roughened by an electro-deposit of platinum, forming a surface to which hydrogen bubbles will not adhere. The platinum is often substituted by silver, which, however, is roughened by depositing a skin of platinum. A variation of this cell has a grid of carbon rods instead of the platinum plate, the surface of the rods being made hydrogen-proof by carbonizing or their jackets of velveteen.

*Bichromate*, consisting of a zinc plate suspended between two carbon plates, which are gripped together at the top above the jar. The electrolyte used is a mixture of separately prepared solutions of sulphuric acid and of potassium bichromate. With this cell the zinc plates have to be raised out of the electrolyte when the battery is not in use, to prevent continuous chemical action, and therefore waste of energy.

*Leclanché* has a solution of sal-ammoniac (ammonium chloride) as the electrolyte, and into this dips a zinc bar in one corner of the square glass jar. The other pole is a bar of carbon within a porous jar, the space within being closely packed with a mixture of manganese dioxide and powder coke. The whole is immersed in the electrolyte. The oxygen escaping from the dioxide prevents polarization of the cell, and the porous jar prevents the oxygen from reaching the zinc, while opposing no barrier to the passage of the electric current. This cell is useful only for intermittent work, such as ringing bells and buzzers.

*Harrison.*—The negative (internal) pole or cathode is a rod of hard lead around which is compressed a jacket of lead peroxide. The other pole or anode is of zinc, cast in the form of a very thick tumbler which is supported by an amalgamated copper rod running down through it and riveted in the centre of the bottom. Around this rod the tumbler is partly filled by pouring in melted zinc amalgam. The electrolyte is, dilute, sulphuric acid, or a solution of potassium bisulphate, or of sodium bisulphate. This is a very powerful battery.

*Caustic Alkali or Copper Oxide Cells.*—This type of cell was introduced in 1881 by Lalande and Chaperon, France. Their cell consisted of a glass jar, in the bottom of which the oxide of copper was contained in an iron cup; the zinc plate was supported in the solution of caustic potash by a wire, from the cover of the jar. To prevent the carbonic acid gas of the air from combining with the caustic potash, the solution was covered with a layer of petroleum oil. This cell has undergone many modifications at the hands of Edison, Gordon and others.

*Edison Primary Battery.*—An oxide of copper battery. The elements employed in it are zinc and black oxide of copper. The solution is of high grade caustic soda, in the proportion of 25 parts of caustic soda to 100 parts of water. The initial electromotive force of these cells is .98 volt; on closed circuit, 0.7 volt. Their internal resistance varies with the size of the plates from .09 ohm to .02 ohm. The capacity of these cells, as commercially

constructed, ranges from 50 to 600 ampere-hours. The oxide of copper cell has the advantage that its internal resistance falls with use, inasmuch as the continued reduction of metallic oxide from the oxide of copper increases the conductivity of the plate; in practice, however, a film of metallic copper is deposited in advance on the copper oxide plate to ensure a low resistance at the start.

The containing vessel of the Edison cell is a porcelain jar having a porcelain cover, through which the connecting wires or rods of the plates enter the cell. The copper oxide plate is obtained by roasting copper turnings, which are then ground to a fine powder and mixed with 5 to 10 per cent of magnesium chloride. The oxide is then molded into plates, which are held in a copper frame in the cell, as at cc, Fig. 1; this frame being attached to the cover of the cell and forming one of the terminals, zz are the zinc plates, one on each side of the copper oxide plates. Batteries of the oxide of copper

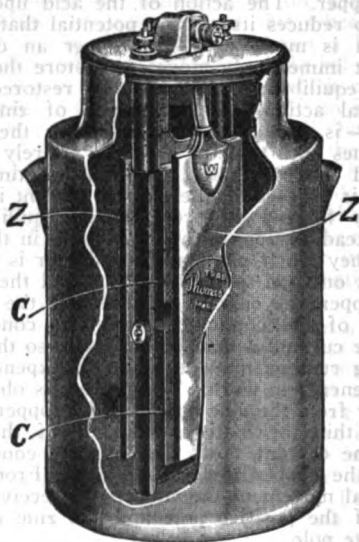

FIG. 1.—Edison Oxide of Copper Battery.

type are extensively employed in connection with spark coils for gas-engine work, and for numerous other purposes requiring continuous current, as these are eminently closed circuit batteries. They can also be used as open circuit batteries.

*Gordon.*—A copper oxide cell used extensively for working fire, police and railway signals, and of economical use anywhere. Although designed for closed circuit work it does well also on open circuits. The outer jar is of glass, porcelain or enameled ware, with a cover of the same materials, or of tin, or compressed fibre. A perforated cylinder of tin-plate is suspended in the centre of the cell by an iron rod. This cylinder is filled with black oxide of copper. On the outer circumference of the cylinder at equal distances are attached three L-shaped lugs of porcelain which support a heavy zinc ring, and at the same time insulate it from the tin cylinder. The electrolyte is a solution of caustic soda, and the surface of the cell is covered with a layer of heavy paraffin oil, which prevents the creeping over



of the caustic. As commonly used these cells give six months' service before renewal is necessary.

**Two-Liquid Batteries.**—Although the one-liquid cells have proved to be adequately non-polarizing, several forms of two-liquid cells retain a hold on the market, and for some of them there is a large demand.

*Daniell*, an annular vessel of copper in the bottom of a jar is piled with crystals of copper sulphate, and within it stands a jar of porous earthenware in which is suspended a zinc bar. The electrolyte in the porous jar is dilute sulphuric acid, or, sometimes, zinc sulphate. The electrolyte in the outer jar is a saturated solution of copper sulphate. This is a closed-circuit battery which has been used extensively for telegraph work.

*Gravity*, a cell with the same components as the Daniell cell, but without the porous jar. The copper element is a spider-like form of sheet copper spreading its legs over the bottom of the jar. This copper form is completely covered with crystals of copper sulphate, or sometimes there is a perforated copper disc laid upon the spider and the copper sulphate is piled upon the disc. In the upper part of the jar is hung a thick seven-toed crowfoot of zinc—from which this form of cell is often called the crowfoot battery. The electrolyte is of dilute sulphuric acid. A concentrated solution of copper sulphate will soon occupy the lower part of the jar, and above it will float the lighter zinc sulphate solution—with, however, some little diffusion where the two solutions meet.

*Minotto*, a cell in all respects like the Gravity cell, but with a flat mat of cloth stuffed with sand or sawdust fitted snugly above the copper sulphate to keep the two solutions quite separate. This battery is much used for railway signal work, in spite of the fact that its internal resistance is very high—from four to six times that of the Gravity cell.

*Fuller*, the approved cell for telephone work consisting of a carbon cathode hung in a depolarizing liquid, a combination of dilute sulphuric acid and a solution of potassium bichromate. A porous inner cup or jar has suspended in it the zinc anode and a little mercury is placed in the bottom. The electrolyte in the porous cup is usually pure water; occasionally a very little sulphuric acid is added.

*Grove*, a cell consisting of a hollow cylinder of zinc, within which is a porous jar containing a strip of platinum. The electrolyte in the porous cup is strong nitric acid, and in the outer jar is dilute sulphuric acid. This cell is used chiefly in laboratory work.

*Bunsen*, a cell very similar to the Grove cell except that it has a bar of carbon in the porous jar instead of the strip of platinum.

#### DRY BATTERIES.

The ordinary commercial dry cell is virtually a Leclanché cell in which the electrolyte is in the form of paste instead of a liquid. It is, therefore, not accurately a dry cell but a moist cell. It is made inside of a cup or cylinder of sheet zinc which forms the anode. This zinc cylinder is lined generally with absorbent pulpboard or layers of blotting paper which are saturated with the electrolyte, a con-

centrated solution of sal-ammoniac. Through the centre of the cell runs a carbon bar constituting the cathode, and around this is packed the depolarizing paste. The composition of this paste is a trade secret, each manufacturer having his own formula. It is pretty well understood that the absolutely essential ingredients and their usual proportions are as follows: manganese peroxide, 100 parts; powdered coke, 80 parts; vitrified graphite, 20 parts; sal-ammoniac, 20 parts; zinc chloride (30° Baumé), 7 parts. Other ingredients which are known sometimes to enter the composition are glucose, dextrine, common salt, lime, arsenic, mercury bichloride, hydrochloric acid and plaster of Paris.

After the paste is firmly packed in nearly to the top, the lining is folded down upon it, a thin layer of sawdust is laid in, a snug collar of corrugated pulpboard is fitted, a layer of sand is spread on; and upon this is melted in the asphalt cover or seal. Some makers of dry cells place next to the zinc, instead of the pulpboard lining, a prepared paste of flour, dextrine and gum tragacanth, with possibly other ingredients.

A strictly dry cell is made in the same way of dry materials without moisture. This cell is inert until it is wet, and provision is made for the wetting by making the carbon bar hollow and perforating its sides. The end is closed with a rubber cork. When the battery is wanted for use, the cork is removed and water poured in. These absolutely dry batteries are made particularly for shipping long distances across the ocean, as in the Egyptian and African trade. (See ELECTRIC STORAGE BATTERIES). Consult Cooper, W. G., 'Primary Batteries: Their Theory, Construction and Use' (London 1916); Schneider, N. H., 'Modern Primary Batteries' (London 1905).

**ELECTRIC BELL**, any bell made to ring by the making and breaking of an electric circuit. Common forms are here illustrated. A familiar design has two electro-magnets, parallel and in series, having at their extremity a vibrating armature in close proximity pivoted between them; fixed to this armature is a clap-

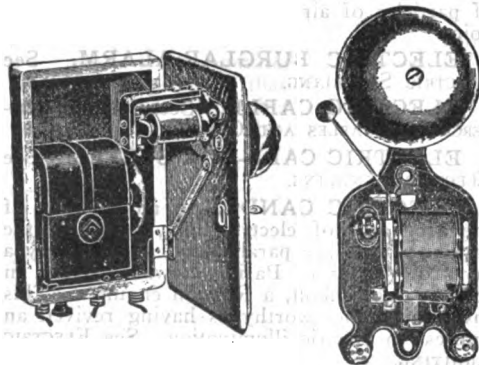

Magneto Bell.  
Door open.

Electric Door Bell.

per vibrating between two gongs. The current passes through the fields, magnetizing the cores, and in generating an alternating current vibrates the armature and rings the bell. A battery bell employs a small cell battery for

power, and frequently a single coil of wire, wound around an iron core; a vibratory armature, pivoted at one end, is arranged to operate the clapper.

Two coils are used in the electric door-bell shown in the illustration. For a more technical description see **ELECTRIC SIGNALING**.

**ELECTRIC BLUE-PRINT MAKING**, a modern process of wholesale photographic printing by the aid of machinery, the electric light and the blue-print (q.v.). One of the best machines is continuous in its operation, and is fed by the operator with great lengths of tracings and blue paper in much the same manner as the washerwoman feeds the wet clothes into a wringing machine. The large wooden drum, around which the tracings and printing paper pass, is moved either by a connection with the shafting or by an electric motor mounted on the apparatus, the speed of the drum being regulated by a device shown on the top of the machine. A traveling apron of transparent material takes the place of the glass in the printing frame of the ordinary type, and as it is under tension at all times, it ensures an even and close contact at all points. This apron is wound on a small drum at the top and after passing along the large drum where the contact and exposure take place, it is wound up on the drum below; after the printing operation has been completed it is rewound by hand back on the upper drum. In the rear of the machine are three arc lamps with reflectors, which concentrate the light on the tracings which, with the exposed prints, drop out into the box in front. The blue paper may be kept in a roll ready for use on the upper front part of the machine, or may be fed in small sheets with the tracings where the work being done is of ordinary size.

The machines are made in two widths, 30 and 42 inches; the apron supplied with them is 70 feet long, and prints of this size can be made as readily as smaller ones where it is desired. The ability to make prints of this size greatly enlarges the sphere of usefulness of the blue-print.

**ELECTRIC BREEZE**, a breeze or stream of particles of air repelled from an electrified point.

**ELECTRIC BURGLAR-ALARM**. See **ELECTRIC SIGNALING**.

**ELECTRIC CABLE**. See **ELECTRIC UNDERGROUND CABLES AND CONDUITS**.

**ELECTRIC CALL-BOX SYSTEM**. See **ELECTRIC SIGNALING**.

**ELECTRIC CANDLE**, a modification of the arc form of electric light, in which the carbon pencils are parallel and separated by a layer of plaster of Paris. It was invented in 1877 by Jablochhoff, a Russian engineer. This invention is noteworthy as having revived an interest in electric illumination. See **ELECTRIC LIGHTING**.

**ELECTRIC CLOCKS**. See **CLOCK**.

**ELECTRIC CONDENSER**, a construction for accumulating electricity, through the effect of mutual induction between conducting plates, as of tinfoil, separated by a dielectric, as of oiled paper; or some similar device as a Leyden jar. When an insulated conductor is

charged with electricity by friction, a battery or other source of electromotive force, it will excite or "induce" in any neighboring conductor a charge of electricity. If the electricity in the first body be "positive," that induced in the neighboring body will be "negative." Thus, in Fig. 1, in which A and B are metal plates separated by air, glass, mica or other insulating material, if A be charged by the positive pole of battery *b* it will induce a charge of negative electricity on the plate B. Such an arrangement of plates is termed an electric "condenser," and in various forms it is one of the most useful instruments employed in multiplex, printing, automatic, wireless and other systems of telegraphy. It is also indispensable in telephony and has found a field in electric light and power circuits. The electricity held or "bound" in the plates is termed static electricity. The quantity of electricity or "charge" accumulated at the plates is equal to the product of the electromotive force of the charging source by the "capacity" of the condenser. In fact, however, what the condenser holds is electrical energy, which, when discharged, is given up as work and heat. The total amount of energy (expressed in foot pounds) thus stored up by the condenser is

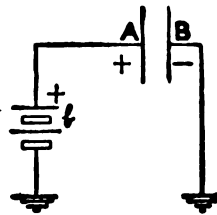

FIG. 1.



FIG. 2.

$(K \times E^2) \div 2.712$ , where *K* is the capacity of the charged condenser in farads, and *E* is the charged electromotive force in volts. It can be shown that the charge of a condenser rests on opposite sides of the dielectric, and that in charging the condenser as much electricity leaves plate B as enters plate A. The capacity of a condenser varies with the distance between its opposite plates, being greater the nearer they are together, and increases with the surface of the plates. The capacity also varies with the insulating material or dielectric used to separate or insulate the plates. The property of dielectrics to which this so-called inductive effect is due is termed specific inductive capacity. The property which this inductive capacity seemingly imparts to conductors is termed electrostatic capacity, or "capacity." The inductive capacity of air is taken as the standard. Air being unity, the specific inductive capacity of paraffin is about 2; vulcanized India-rubber, 2.94; gutta-percha, 4.5; mica, 5; flint glass, 6.5 to 10. The Leyden jar is a well-known type of condenser. The most common form of condenser is generally constructed of many sheets of tinfoil, separated by thin sheets of insulating material, such as paraffin paper, mica or glass; the alternate sheets of tinfoil are connected together metallically at their ends as indicated in Fig. 2.

In making a condenser for radiography, the glass plate type is recommended as inexpensive and durable, and also much lighter than oil-

immersed types. Photographer's negative glass, tinfoil and shellac are the materials. The foil should be cut to the required size ( $6 \times 8$  inches is convenient), and carefully smoothed to take out all wrinkles. The glass should be cleaned with alcohol and coated with shellac, then covered with the foil, and rolled or "squeegeed" so as to be perfectly smooth. In assembling the plates lugs should be placed between them. A unit may be made of 10 plates which are bound together with wire or suitable tape, and immersed for one hour in a bath of equal parts of hot melted rosin and beeswax, then allowed to drain and dry. This gives a condenser unit thoroughly moisture proof, with a capacity of .01 microfarad, which is suitable for the ordinary half-kilowatt wireless transformer for the standard 200-metre wave-length. It is good practice to make four such units, placing two multiple sets of two in each series; this reduces the strain on the condensers, without altering the capacity. They may be mounted in substantial open-side wooden boxes to protect the plates from injury.

**ELECTRIC CONDUCTIVITY**, the property that a substance, as a metal, possesses of conducting an electric current, that is of permitting a current to flow more or less readily: called also conductance. It is the opposite of electric resistance. All the metals possess some degree of conductivity and some degree of resistance, iron being conspicuous in presenting an almost equal degree of these opposite qualities. It will be seen by the following table of comparisons that silver is the best and mercury the poorest conductor.

Metal.	Electric resistance in Microhms at 0° C	Relative Electric conductivity, Mercury = 1.
Silver.....	1.52	66
Copper.....	1.61	62
Gold.....	2.08	48
Aluminum....	2.94	34
Iron.....	9.82	10
Lead.....	19.85	5
Mercury.....	99.74	1

**ELECTRIC DIRECT CURRENT**, as distinguished from the alternating current, is so-called because of the fact that it travels in one direction along a conductor. If this conductor joins the terminals of a source of energy, as a dynamo, the current is said to flow from the positive pole of the machine along the conductor to the negative pole.

Probably the first man to detect current electricity was Galvani about the year 1786. To Volta (q.v.), however, is certainly due the credit of first developing a practical electro-chemical cell. In the year 1800 Volta exhibited a cell known as the "Voltaic Pile," consisting of a series of discs, copper and zinc, alternately separated from each other by a cloth saturated with brine; on joining wires to the end discs, quite a perceptible shock may be felt by touching with the tongue or moistened finger the two terminals simultaneously. This simple device was the starting point of all the electro-chemical batteries of the present day. With the discovery of Volta of the laws of difference of potential between different metals when placed in contact or joined by a fluid electrolyte began the development of very many varieties of cells, all on the same principle; yet even now, the two metals he chose,

zinc and copper, constitute the elements of the Daniell cell very frequently used for telegraphic purposes. The changes which would readily suggest themselves in Volta's first cell would be, increasing the amount of corroding liquid and placing the elements, zinc and copper, in a vessel which would properly contain the fluid.

The theory as given by Gore of the electro-chemical cell is as follows:

"The essential cause is the stored-up and ceaseless molecular energy of the corroded metal and of the corroding element or liquid with which it unites, while contact is only a static condition; and chemical action is the process or mode by which the molecular motion of these substances is more or less transformed into heat and current."

The electromotive force of chemical generators is small, rarely exceeding two volts per cell. This necessitates a large number of cells connected in series; that is, the positive terminal of one connected with the negative terminal of the adjoining cell, the electromotive force thus produced being the product of the electromotive force of one cell by the number of cells. By connecting the two positive and the two negative terminals of two rows of cells, an increased quantity of current can be obtained, at the potential of one row. The first method is called joining battery cells for intensity, and the second for quantity. It is known that the energy generated in a chemical cell is produced by the consumption of zinc. The cost of this energy must necessarily be high, as both the zinc and the chemicals are expensive, so that the use of current electricity was quite limited until the introduction of the dynamo electric machine, which might be called the mechanical method of transforming energy from some source, such as a steam-engine, into current electricity, as contrasted with the chemical method.

In the year 1831 Faraday discovered and announced the principle of electro-magnetic induction. This opened up the field of what might be called the commercial generation of current electricity. The principle discovered by Faraday, which forms the basis of all dynamo electric machines, is that if a wire is moved in a magnetic field, so as to cut the lines of force, a current will be generated in the wire, and it is upon this principle that all dynamo electric machines depend for their action. The converse of this law he also announced, namely, that when an electric current is applied to the dynamo by some external source such as a battery or another dynamo, the machine will furnish mechanical power. Hence a dynamo electric machine may be considered either as a generator or as a motor.

All dynamos consist of two essential parts, one, the field magnet, which is usually stationary, and the other, the armature on which the copper conductors are mounted and which revolves on a shaft between the poles of the field magnet. This armature is so arranged as to cut the lines of force flowing between the magnetic poles. The lines of force are imaginary lines flowing from the north pole to the south pole of any magnet. They can easily be traced by placing a piece of paper above the magnet and sprinkling on this paper iron filings.

If the paper be covered with mucilage the filings will maintain a permanent position so that they may be studied at the leisure of the student.

The field magnets may be made of steel, magnetized, or preferably they may be electromagnets made of soft iron over which a coil of wire is wound carrying a current of electricity which induces magnetic lines in the iron. It is to be noted that if the ends of the magnet are bent in the form of a horse-shoe, the lines will be intensified by the reduction of the air space between the poles, and as the amount of current induced in the wire depends on the number of lines of force cut, the current induced will be greater, the greater the strength of the field magnets.

Considering first the ideal simple dynamo: This would consist of a single loop of wire mounted on centres, and rotating between the poles of a magnet, placed horizontally, each end of the loop being connected to a collector which in direct current machines is called a commutator, and is mounted on the shaft outside of the poles, and insulated therefrom. If the loop is placed at right angles to lines of magnet force, in a vertical position and revolved through 180 degrees, each side will pass through the whole number of lines of force flowing between the poles which will induce a current in one direction in the loop. If the rotation is maintained in the same direction during the next 180 degrees, the loop will cut the lines of force in the opposite direction, that is, the lines of force will be passing through it in the opposite direction to that in the first case. This will induce a current which will be in the opposite direction from the current induced through the first half of the revolution; so that the current will be pulsating, first in one direction and then in the other, during each revolution. If the collector or commutator be cut into two halves parallel with the shaft and the ends of the loop be connected one to each half, and if a pair of brushes be supplied to collect the current, one above and one below the commutator, then when the loop is vertical the brushes will change contact from one end of the loop to the other, and as no current is then being generated, the change is made without sparking and current flowing in the same direction continuously can be obtained from the brush terminals. During the moment of changing from the one contact to the other, the circuit is momentarily opened or interrupted. This would cause sparking at the brush or collector, were it not that the brushes are placed at a point at which the current is practically zero. This is found in practice to be slightly in advance of the theoretical neutral point on account of lines of force being dragged in the direction of rotation by the conductors.

To advance from the ideal simple dynamo: — the next step is to reduce the air gap between the poles of the field magnet and concentrate the lines of force in the effective space. This is accomplished by placing an iron core on the armature which in the first place reduces the magnetic resistance of the air gap and thus increases the number of lines of force through the armature conductors, and also serves as a support for them. Other machines were built with shuttle wound armatures, the arm-

ature consisting of an iron shuttle cut out with grooves longitudinally to take the conductors. These were usually wound with a number of turns of copper wire, the ends being brought out to a two-part commutator. (See ELECTRIC ALTERNATING CURRENT MACHINERY). The next step was to add to the number of coils on the armature so that during each portion of a revolution some part of the armature conductors would be doing maximum work. Should an additional coil be added to the ideal generator, at right angles to the first coil, the capacity of the machine will be doubled. This complicates, to some extent, the collector rings and may necessitate the opening of the circuit when current is flowing so as to cause sparking and burning of the brush. A machine built on these lines would, therefore, be better adapted for generating small currents as the sparking at the brushes would be otherwise very destructive to the commutator. Machines of this type are known as open coil.

The next important step was made by Gramme and Pacinotti, which was to close the coils with themselves so as to form a continuous circuit in the armature and connect one collector section to each coil at its junction with the next one, the number of sections being the same as the number of coils. In the four-coil armature, the current generated can either pass to the collecting brush directly, or when it moves out of position so that the contact is broken and made with the next section, the current can flow through the armature coils to the same brush if necessary, and when that coil passes from one polar position to another and is giving current of opposite polarity this current can flow directly to the other brush, and so continuous current is generated. There is also no point at which the circuit is open. There may be a slight sparking as the section moves from the brushes, but violent sparking is reduced as there is always another path for the current to flow to either brush.

The drum armature is distinct from the ring armature in that the wires are wound on the outside of the core and do not pass through it. This type is frequently called the "Siemens" armature on account of the number of successful machines built by Siemens. Of the whole number of lines of force passing between the poles and through the core, there are very few lines passing in the inside, they being diverted by an iron core so that they pass through the wires on the outside of the core; the conductors inside of the core are thus of little use, their only function being to complete the circuit and carry current between the successive turns on the outside of the core; so that by winding the wires on the outside surface only, the amount of idle wire is reduced, the only material that is not active being the cross-connecting pieces at the ends.

The Gramme ring was used very largely on early machines for the reason that it afforded means for easier mechanical construction, and machines of this type were generally successful, on account of their simplicity. Pacinotti designed a core having teeth similar to a gear wheel. In this way the air gap between the armature and pole pieces could be reduced somewhat, resulting in an increased number of lines of force. It also afforded an additional

support to the coils and added to the mechanical strength of the machine.

To be considered next are the field magnets: There are a number of constructions which may be employed. (1) The so-called permanent steel magnet which consists of a bar or bars of steel bent to the shape desired, tempered and magnetized. The method of magnetizing these magnets consisted of placing them in contact with other magnets or with an electro-magnet. The present method would be to insert the steel bar into a helix carrying a heavy current and in a short time the bar would be magnetized. The dynamos built with permanent steel magnets of this type are what is known as magneto dynamos. The chief objection to this form of magnet is that a steel magnet cannot be made as powerful as an iron magnet which is energized or, as it is commonly called, excited from a source of electricity. In the first generators permanent magnets were used, but a great step in advance in dynamo design was to arrange the magnet poles so as to be self-excited. A portion of the current generated in the armature is sent around the coils wound around the cores of these field magnets so as to excite them. At first, however, magnets were substituted consisting of soft iron upon which was wound a coil of copper wire, the current for energizing these pole pieces being first supplied from a small magneto generator or a voltaic battery. Sometimes the machine will not generate on starting up not having sufficient current to excite the magnets and it is necessary to excite them from some external source so as to give the initial strength to the magnets and allow them to build up from the current generated in the armature. It is usually found that there is sufficient residual magnetism left in the iron of the field magnets, after the machine has once been in operation, to start the current in the machine and properly build up the fields.

In regard to field windings, two distinct types are used: (1) the series winding, in which all the current generated in the armature passes around the field poles and thence out to the line or circuit; and (2) the shunt winding in which a portion only of the current is used in the field, the connection being made across the main terminals of the generator. In the first case the wire on the field windings is necessarily large so as to carry all the current for which the machine is designed and in the second case it is a small wire of many turns, the product of amperes and turns being about the same in either case. In another design, both a shunt and a series winding of a few turns is employed, constituting a compound winding.

It will be seen that in the first case, that of the series winding, the field strength will depend upon the resistance of the total circuit, including the resistance of the armature, the field winding and the external circuit. In a machine of this type the voltage or pressure generated will vary in proportion to the demands. This is the standard winding for the series arc machines used for city lighting, such as the Brush and Wood types. In the case of the shunt-wound machine the current flowing in the field coil depends upon the pressure between the generator terminals, so that with an increased output and consequent loss in the

armature the voltage will fall off slightly, thus reducing the field strength. This necessitates some means of varying the field current so as to maintain a uniform pressure at the generator terminals. This is usually accomplished by means of an external resistance in the field circuit composed of German-silver or iron wire which can be varied by means of a switch-head so arranged as to cut out certain portions of this resistance step-by-step and so increase the current through the fields, thus preserving a uniform voltage.

In a combination of series and shunt windings commonly called the compound type, as the output of the generator is increased, there is a greater flow of current through the series windings and consequent increase of magnetic strength of field so that it is possible to compensate for the loss due to the resistance of the armature windings and maintain a uniform voltage at the generator terminals. The voltage as well as the output of the dynamo depends upon the strength of the field magnets, the magnetic permeability of the material and the rate at which the lines of force are cut by the armature conductors, so that the higher the speed the greater the voltage output of the dynamo. In the early machines very high speeds were common, armatures of small diameters being employed. These were objectionable for mechanical reasons so that the design was changed in order to increase the number of pole pieces. Instead of the field being composed of two poles, it was arranged so that a greater number of poles could be used, this type of machine being known as the multipolar dynamo. As each conductor would pass between a number of poles during each revolution the speed could be proportionally reduced.

The dynamo, as previously stated, is a machine for converting energy in the form of mechanical power into electrical power, or vice-versa, so that a motor is a machine for converting energy in the form of electricity into mechanical power. The early types of motors were based on the principle that a magnet would attract the opposite pole of another magnet, and if one set of magnets is arranged on a wheel, and the other stationary, the movable magnets will be drawn around. To make this effective it will be necessary to interrupt the forces at what might be called the dead centres so that the wheel would have continuous motion. This is accomplished by either introducing a screen, or, more satisfactorily, by the use of electro-magnets with a movable contact so that the magnets are energized intermittently, allowing the wheel to revolve in accordance with impulses received from the magnetic poles.

When we consider the dynamo as a motor, the current supplied to the terminals may take two paths, one through the armature and the other through the field coils. The field current energizes the pole pieces, and the current traveling in the armature is similar to another magnet inasmuch as a coil carrying the current will be attracted or repelled by a magnet according to the direction of the current through the coil, so that the wire will be forced around by attraction and repulsion. By considering the effect of the commutator the motion is seen to be continuous. When the armature starts to revolve the conditions then existing will be

similar to the armature in action as a dynamo, and an electromotive force will be generated in the armature wires, which will be in the opposite direction to the incoming current. This is what is called the counter electromotive force of the motor, and will tend to reduce the amount of current which will flow through the armature conductors. It is, therefore, evident that when a motor is started there will be a rush of current through the armature, as the resistance is very small, and as there is no counter electromotive force while the machine is not in motion to check the flow. For this reason, in the direct current motor it is necessary to introduce an external resistance into the armature circuit to hold back the current which would flow, until the machine approaches full speed. The resistance is then gradually reduced until full speed is obtained. The effect of this counter electromotive force when the resistance is cut out entirely is materially to assist the self-regulating qualities of the machine. Any load applied to the motor would tend slightly to reduce the speed, which effect, by also reducing the counter electromotive force and allowing more current to flow through the armature, tends to keep the speed from falling much below normal in the shunt motor. Motors can be built either with a plain shunt field winding or with a series and shunt winding, depending on their requirements. The direction of rotation depends on the direction of the current through the armature. To reverse the rotation, therefore, it is only necessary to reverse the current in the armature, leaving field connections as they are. If the current is changed in both field and armature, the result would naturally be that the machine will continue to revolve in the same direction as before.

To reduce the speed of the direct current motor it is only necessary to add resistance to the armature circuit so as to limit the current flowing therein, and by so doing almost any desired speed may be obtained, from 1 per cent up to full rate of speed. There are a number of other methods by which variable speeds can be obtained, one of them being by varying the field strength. Any motor, however, operating at a lower field or armature current than normal conditions would require is naturally operating at reduced power. On account of the valuable features in relation to speed control, reversibility and the automatic speed control inherent in the shunt machine, together with the large torque of the series machine, the direct current motor fulfils more nearly than any other the practical requirements in machine-shops, textile mills and general manufacturing establishments.

For electric railway work, in which the direct current is employed (see TRACTION, ELECTRIC), the compound wound generator and series motor is the usual standard practice. Often this type of generator is overcompounded so as to more than overcome the drop through the armature resistance and allow higher voltage at full load than at no load, so as to overcome, in a way, the drop of potential on the feeders and preserve the uniform voltage over the system. In lighting and power work the shunt and compound dynamos are both used. (See ELECTRIC LIGHTING). And

in the business centres of our large cities where the direct current is generally used, the rotary converter fed from a high tension alternating central station is very often employed, together with storage battery.

Direct current was more generally used in the earlier installations of electric distribution, in preference to alternating current, for the reason that the direct current motor was developed before the alternating current motor; and the earlier motors possessed many advantages in their ability to be operated at any speed from slow speeds up to the maximum speed for which the motor was designed, and also permitted the use of storage batteries directly connected to the system, thus ensuring continuity and reliability of service.

The shunt and series motor each has its own field of usefulness. When a very powerful starting torque and rapid acceleration are necessary the series motor is used, as in the case of street railway, electric locomotives, electric cranes; and on steamships where the direct current alone is used, as on the *Kentucky* and *Kearsarge*, of the United States navy, not only is electricity used for lighting, but also for operating ammunition hoists, hoisting anchors, operating boat cranes, and even the steering gear of the ship itself.

In machine-shops and manufacturing establishments where a more or less constant speed may be required, and in elevator work, the compound and the shunt motor are commonly employed. The shunt motor is very well adapted for operating at any speed desired, and for machine tools it is at present without a peer for an efficient and easily regulated source of power. Unlike the series motor, where the speed varies with the load, the shunt motor is practically a constant speed machine. When thrown on the lines it rapidly comes up to normal speed, and then from no load to full load will not greatly deviate therefrom unless purposely thrown to a slower point by the controller. As a series motor would run away if left in a circuit with a load suddenly removed, the shunt motor, or sometimes the compound (which is used in order to preserve an absolutely uniform speed from no load to full load, and is necessary in a few places where absolutely constant speed is required) is the standard motor for driving textile machinery in large mills, factories and other establishments.

Direct current generally meets all of the requirements of the consumers, as it is available for motors of any size; for lighting; for chemical action, such as charging storage batteries or in electro-plating; or for electric heating.

With the large increase in the requirements of individual consumers, the advantages of direct current over alternating current are not as important to-day, for the reason that translating devices have been simplified so that alternating current may be converted, without serious difficulty, into direct current, for any special requirements.

WM. C. L. EGLIN,  
*Second Vice-President and Chief Engineer,*  
*The Philadelphia Electric Company.*

**ELECTRIC DISCHARGE**, the escape of electricity, whether slowly and silently, or more quickly and violently, from any receptacle or generator.

**ELECTRIC DOOR-BELLS.** See **ELECTRIC BELLS; ELECTRIC SIGNALING.**

**ELECTRIC DRILL,** a drill for metals or rock worked by an electromagnetic motor. For metals a rotary motion, for rocks a reciprocating or percussive action, is imparted.

**ELECTRIC EEL** (*Electrophorus electricus*), a great eel inhabiting the marshy waters of the llanos in South America. It belongs to the family *Gymnotidae* and order *Plectospondylii* (q.v.), and with a few allied species is distinguished from all other eels by the partial coalescence and modification of the anterior vertebrae. It is remarkable chiefly for the great size of its electric organs, which consist of two pairs of longitudinal bodies between the skin and the muscles of the caudal region, divided into about 240 cells and supplied by more than 200 nerves. The eel can discharge sufficient electricity to kill an animal of considerable size, and is said to possess power, when in full vigor, to knock down a man and benumb the limb affected, in the most painful manner, for several hours after communicating the shock. By frequent use of this faculty it becomes impaired, and a considerable interval of rest is required to recruit its electrical properties. According to Humboldt the natives of South America make use of horses in taking the electric eel. The animals are driven in a body into a stream or pond where the fishes abound, and the latter, having exhausted their stores of electricity by repeated attacks upon them, are then easily taken. The horses are sometimes so severely stunned by the shocks that they fall and are drowned. Specimens of the *Electrophorus electricus* are reported to attain the length of six or seven feet, but ordinarily they are about three and one-half or four feet long. See **ELECTRIC FISHES.**

**ELECTRIC EGG,** an ellipsoidal glass vessel, with metallic caps at each end, which may be filled with a feeble violet light by means of an electric machine acting on it after a vacuum has been made inside the glass.

**ELECTRIC ELEVATORS.** See **ELEVATORS.**

**ELECTRIC ESCAPEMENT,** a device actuated by electric impulse which intermittently arrests the motion of the escape-wheel and restrains the train to a pulsative motion—acting, in fact, in the place of a pendulum.

**ELECTRIC FARMING.** The greatest agent for the advancement of agriculture is electricity. It is the emancipator of the toiler. A motor of even diminutive dimensions accomplishes more work than a man—at less expense—since the power developed by the human machine is the most expensive that man uses. In supplanting manual labor, electricity has a most appreciable effect upon agriculture, due to the fact that agriculture requires great labor with a minimum of skill. In reducing manual labor by the use of electricity, the farm operatives, with the exercise of but little mechanical knowledge, may direct the operations of numerous large electrical units and accomplish an aggregate of work that would be absolutely impracticable under ordinary conditions.

In the installation of electricity on the farm, it is necessary, however, that the farmer—

user of many and infinitely varied implements and mechanical devices—should avail himself of the co-operation of the engineer; taking advantage of the skill and experience of the latter in adapting the new method to his needs, in order to increase the production of his land. Rural industry in general must look to the engineering profession more and more for the most available utilization of our natural resources through the medium of electrical energy.

Industrially considered, the farm is a large user of power, but the sources from which it is derived are at present uneconomic and inadequate in comparison with industrial standards in other lines. Of the 33,000,000 persons engaged in gainful occupations in the United States, not less than 10,000,000 devote their energies to agriculture. In addition, upward of 90 per cent of all the horses and mules in this country are devoted to farm labor. The substitution of electric power, therefore, for even a small proportion of the work of farm animals will result in great national economy.

There is no form of service that can supplant manual and animal labor on the farm or country estate as expeditiously from every standpoint, considering expense and convenience, as electricity, and it will be found superior to steam or to any internal combustion engine. In fact, there is no other existing agent that is able to supply the three necessities—light, heat and power—from one and the same source. Due to this fact, hours of labor on the farm or in rural communities may be regulated, as are those of the manufacturing and commercial industries. In consequence, life in rural communities may be made attractive, as much or more so than that of the cities, where the struggle for existence is incessant, and living accommodations—or what corresponds to home life—fall short of the pleasant and healthful surroundings of the countryside.

The giant industries of the country are of recent origin and were started in a humble way, but they now surpass any branch of the agrarian pursuits. This is a condition readily explained, due to the employment of the services of the trained engineer to the advantageous upbuilding of the great manufacturing industries. On the other hand, farming—the oldest of all industries, and the most basic—has been neglected, even to the point of being abandoned in many places.

The machines and implements of use on a farm are manifold—ploughs, rollers, reapers, threshers, corn shellers and grinders, shredders, fodder cutters, wood saws, pumps, horse and sheep clippers, and apparatus for unloading and hoisting hay, corn fodder and like products. Another phase of farm life in which a great saving of labor is effected by the use of electricity is in the operation of washing machinery, carpet cleaners, sewing machines, fans, cooking and laundry appliances, none of which could well be served by any other agent than electricity. Besides the preceding partial enumeration of the possible applications of electricity, for power, the electric energy—supplied to its motors either from an outside source or from its own central plant—may be used for light and heat.

Where connection cannot be made with a local electric distributing concern, the farmer should have his own generating station, which

may be operated by water, steam, gas, gasoline, oil or windmill power. Where a stream runs through a farm, or is in the neighborhood, cheap power, both as regards first cost and operating expenses, may be derived from this natural source.

In generating the current by steam power, the cost per kilowatt hour is comparatively high. Somewhat better results may be obtained with a gas-producer plant, which, instead of burning the coal in a steam boiler and using the steam for driving the engine, burns the coal gradually in a producer, generating gas for operating the gas engine.

Gasoline, oil and alcohol engines work on the same principle as the gas engine, as all are of the internal combustion type. Great strides have been made during the past decade in this type of engine, so that it operates with an economy and a precision that requires but little attention.

Another source of energy for the generation of electric current for farm and country residences is the windmill. The early Dutch windmills were built with sweeps of from 50 to 100 feet in diameter, while our modern American windmills have a sweep of only from 12 to 18 feet, but generate more power than the earlier type, with less attention.

All of the above primary powers may be connected to the electric generators by belt, gearing or couplings, and their control may be regulated automatically, so that they require but little attention. There are, of course, certain matters in their operation that experience has shown to be of advantage. For instance, the greatest quantity of energy being required for the daytime, and the load for illumination being small, and wanted principally in the evening, it is therefore not profitable to operate the prime movers other than during the day. The use of the storage battery is therefore of great service in supplying electric energy at periods of small demand, when the generators are shut down. In connection with the storage battery, and with the development of the low-voltage Tungsten lamps, the cost and size, as well as the maintenance expense, may be considerably reduced by proper engineering.

The great advantage, in which lies the superiority of a farm operated by electricity, is in the fact that the farmer has at all times under his direct control the entire supply of electric energy available, whether obtained from a public service enterprise or supplied by his individual plant.

Electric farming, while in general use in Germany for the past 20 years, has recently made rapid strides in the United States, particularly in the West and on the Pacific Coast, where central station enterprises encourage the use of electricity for agricultural purposes. There are, however, to be found in the State of New York several notable water-power installations on farms. For instance, there is a 100-acre farm near Oriskany Falls, Oneida County, N. Y., devoted to hop raising, mixed farming and dairying, on which has been installed a 17-horse-power hydro-electric plant, supplying electricity for lighting the farm buildings and for operating various electric motors. The power-dam, of timber-crib construction, is 36 feet long, raising the water four feet, is carried on heavy concrete sills cast in a

2×1.5-foot ditch dug across the stream bed. A row of 12-inch flash-boards held erect by chains positioned by pins removable by a capstan, dropping the boards in case of high water, is above the crest of the dam. There is also provided a supplementary 40-foot spillway, its crest being slightly higher than the main dam, permitting the discharge during heavy floods. A 60-foot canal and forebay lead from the dam downstream to the power-house, where a 17-horse-power turbine wheel has been installed. The latter, by means of belt drive, operates a 12.5 kilowatt generator at 1,100 revolutions per minute. The power-house is 12×16 feet in size.

The drainage area of Oriskany Creek at the point utilized by this plant is 14 square miles, ensuring a supply of water the year round sufficient to drive the plant at full load under the available head of six feet. The distance from the power plant to the farm buildings is 1,700 feet, the current being carried on an aluminum wire stretched on 20-foot poles, 100 feet apart. From the power generated, practically every bit of machinery on the farm is operated, comprising a circular saw, machine lathe and drill press, vacuum cleaning system, adapted likewise for the operation of the milking machines in the 25-stall cow-house, a cream separator, churn, grindstone, ventilating and cooling fans, electric iron, sewing machine and pump. In addition, besides lighting the premises, five electric heaters are operated, maintaining a constant temperature of 75° throughout the winter. Engineering estimates place the cost of the entire equipment at about \$1,800—dam, power-house, line and equipment—but in its efficiency it is worth many times this sum.

A system that has been adopted much abroad is the installation of a rural central station capable of supplying a number of farms, local industries and country estates with electric current. This may be supplied with power generated by steam, water, gasoline, oil or gas, the co-operative feature resulting in a great saving in the production of electric energy. An example of the service supplied by a single central station in supplying a farming community may be seen in that of Lottin, Germany. Here a water power of 300 horse power is utilized. However, during certain seasons of the year, when the water is low, a steam generating set of 180 horse power is put into use to keep up the service. It is obvious that this supplemental power may be pressed into use at any time, should the demand for power exceed the capacity of the hydro-electric station.

The distributing system of the Lottin station is 82 miles long. The electric energy is used on 61 farms, including rural industries, and five villages, a total of 24,700 acres. Altogether, 102 consumers are served, these having some 150 motors with a total of 1,500 horse power, the lighting equipment comprising 4,850 incandescent and 20 arc lamps. In one year the consumption amounted to 440,000 kilowatt hours. There are 50 farms, with an acreage varying from 60 to 1,800 acres per farm, under cultivation by the plough, with a total of 275 horse power in motors, 1,200 incandescent lamps and 20 arc lamps. Of these farms, 12 contain from 300 to 600 acres each, using 12 motors with a capacity of 122 horse power.

In order to give in concrete form the amount of electric energy necessary on a farm, the fol-



## ELECTRIC FARMING

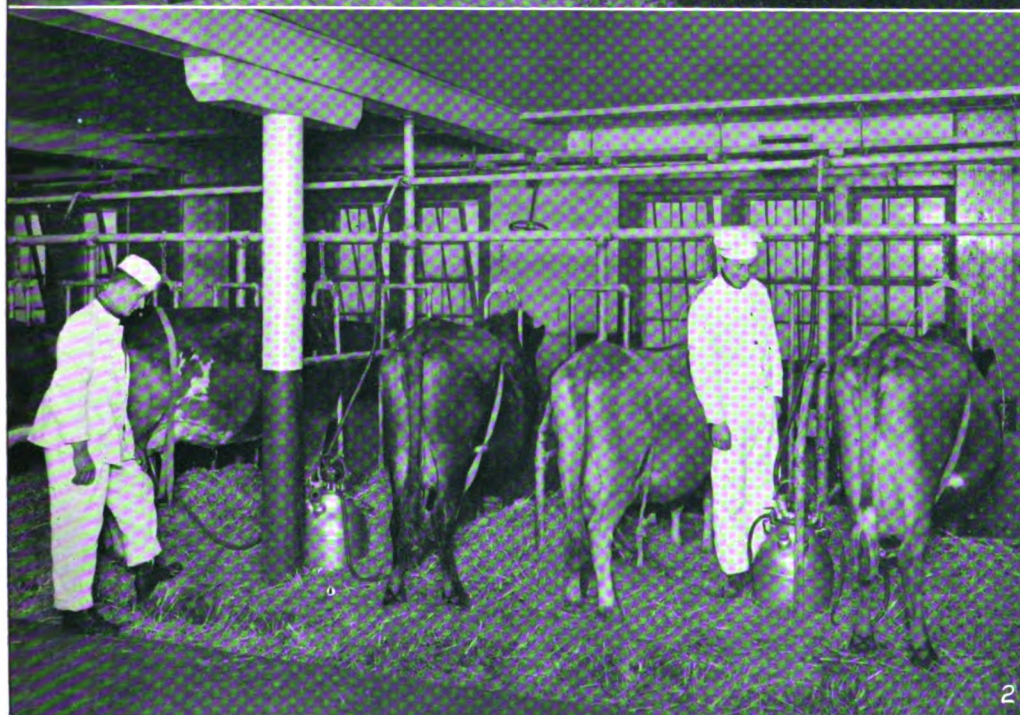
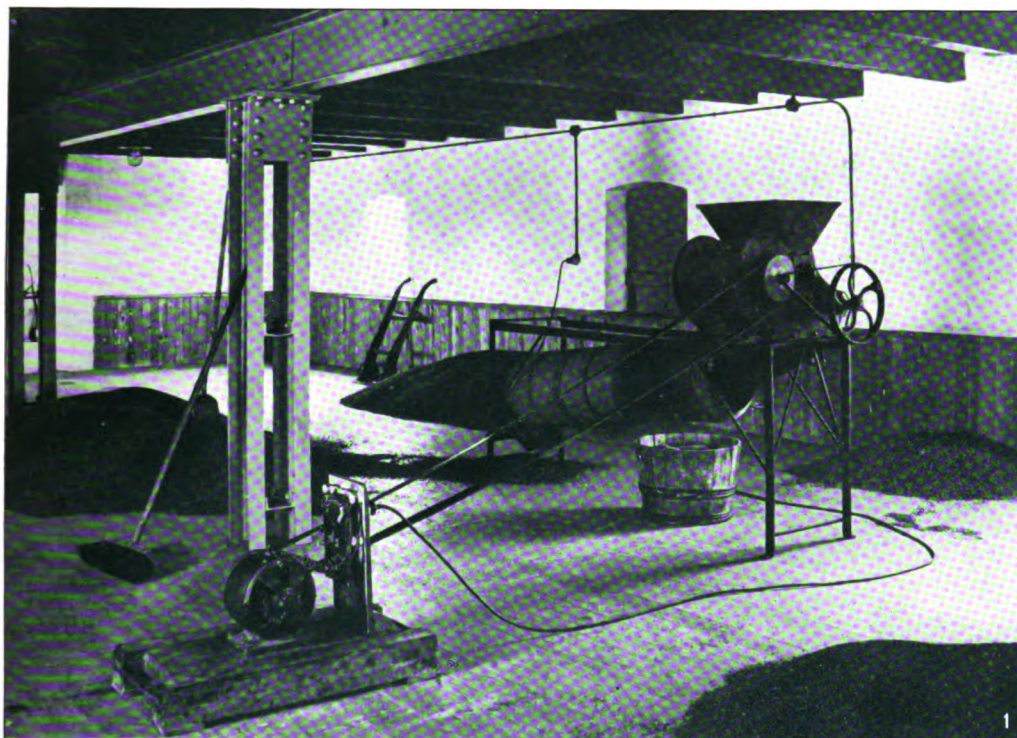

1 Portable Motor Driving Corn Sheller

2 Milking Machines Operated by Motor-driven Vacuum Pump

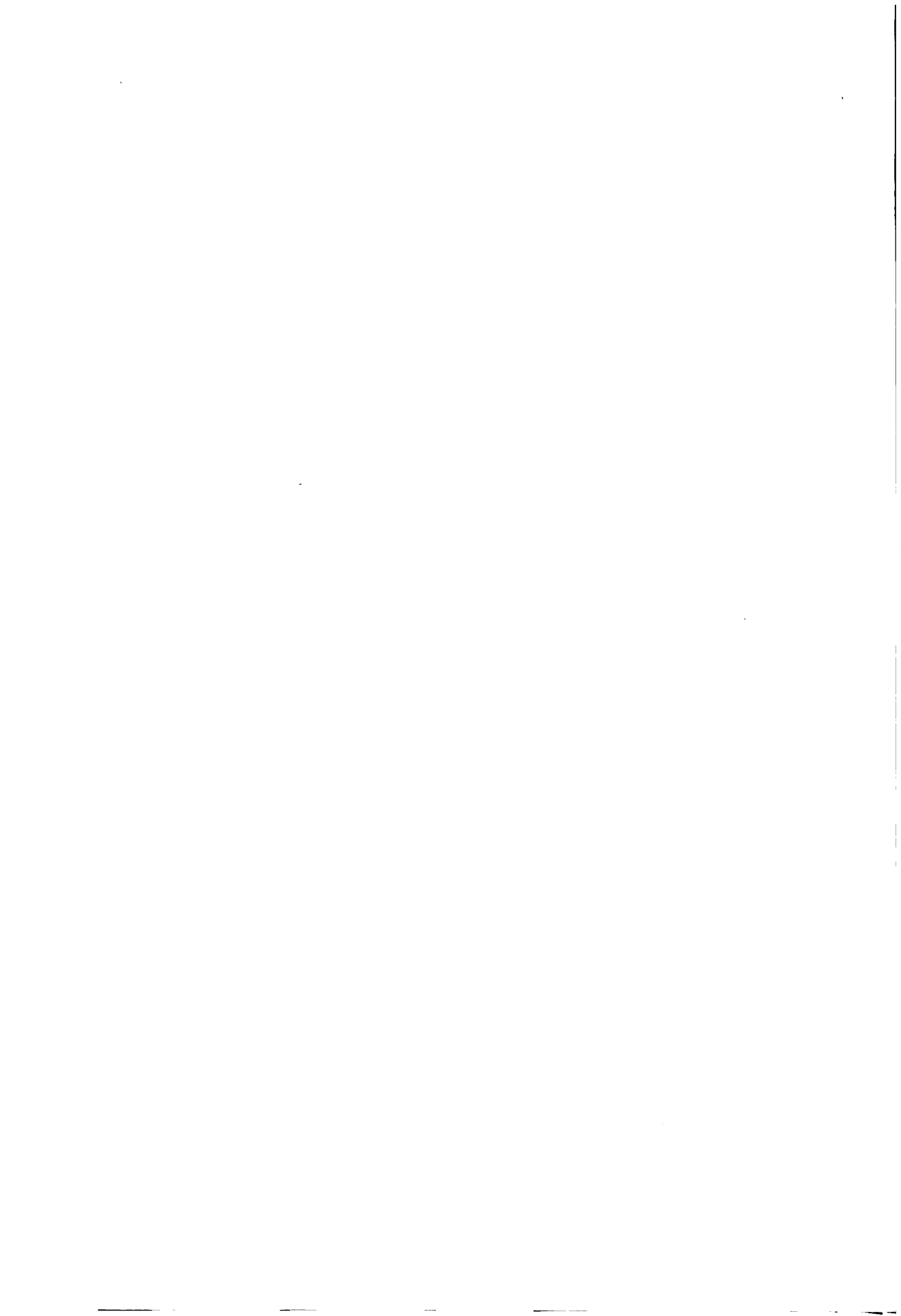

lowing figures from a 100-acre farm are given. It is assumed that two-thirds of the products are of a stalk nature, and that the live stock consists of 3 horses, 10 cows, 15 swine, etc. The figures are an average, taken from the actual experience of a number of farms. It is also assumed that electric energy for power purposes is 5 cents per kilowatt hour, which is a reasonable figure for current used for power purposes only, when purchased from a public service corporation.

The average amount of water consumed on a 100-acre farm is as follows: for the house, for each person per day, 5 to 6 gallons; for cattle, from 12 to 15 gallons per head; for swine and sheep, 1 to 2½ gallons. For pumping 1,000 gallons to a tank elevated 35 feet, the power necessary is about one-eighth kilowatt hour, so that the yearly average energy for 3 horses, 10 head of cattle and 15 swine is about \$4.

For a threshing machine of the smaller size, capable in 10 hours of threshing, cleaning and sacking, ready for the market, 80 to 200 bushels, 3 to 5 electric horse power are required. For machines of from 160 to 240 bushels capacity, 5 to 7 horse power are necessary; and from 300 to 800 bushels, from 10 to 20 horse power are required. The energy required for the various products to be threshed and cleaned, per 100 bushels, is, for rye, 25; wheat, 22; oats, 19; and barley, 21 kilowatt hours, or on the average, 22 kilowatt hours, costing \$1, which is at the rate of \$0.011 per bushel. If hay-baling machines are attached to the thresher, from four to six additional horse power are required.

Fodder cutters, varying from one to two horse power, consume 1.8 kilowatt hours per 100 pounds of fodder, costing 1/16 cent a cut, and as 10 head of cattle consume per year 60,000 pounds of cut beets, etc., the total cost annually for the energy used to operate the fodder machines is 50 cents per head.

One of the by-products of cotton-seed or linseed-oil mills is sold as meal or as cake, and to break it up a special machine is necessary. Such a machine often has a capacity of from 2,000 to 3,000 pounds per hour. The average amount of food per head of cattle is from 2 to 3 pounds per day, which amounts, for 10 head, to about 9,000 pounds per year. The cost of electric energy for operating this machine is 25 cents per year for each animal.

As the cattle are fed from 2 to 3 pounds of crushed grain per day per head, and as there are 10 altogether in the 100-acre supposition, a motor-driven grain-crusher is required, capable of crushing some 9,000 pounds per year. This might be prepared at one operation by a large mill, but for the purpose at hand a motor varying from 3 to 5 horse power, according to the size of the mill employed, will do the work conveniently. To grind 100 pounds costs \$0.03 for the energy consumed, or for the 9,000 pounds, \$2.70 per year.

For running the cream separator, a small motor of about one-fourth horse power can operate 300 quarts of milk per hour, consuming three-tenths of a kilowatt hour, at an expense of \$0.01½. As the average production for 10 cows is about 30,000 quarts per year, the yearly cost of operating the separator is \$1.50.

A churn for 200 quarts of milk, assuming average conditions, requires from one-fourth to

one-half horse power, as also does the butter-kneader, and the cost is negligible.

A washing-machine, including wringer, operated by a one-fourth horse power motor, costing complete \$165, is used 260 hours per year, or some 5 hours per week. As other work may be done by the woman operating it, her time amounts to but 65 hours during the year. The machine turns out three washes an hour, and the total expense of the whole 780 washes is \$35.41. This includes all labor, power and every expense, including overhead charges, and the same applies to the figures for the following machines.

A horse-groomer, costing \$75, operated by a one-horse power motor, cleans 4 horses in 36 minutes. It is used 328.5 hours during the year, or 2,190 groomings, and requires the services of but one man. The cost amounts to \$72.93, or \$0.03½ per horse per grooming.

A cream-separator having a capacity of 1,350 pounds per hour is operated by a 1½ horse-power motor, and costs complete \$350. It is used 183 hours during the year, separating 237,900 pounds of milk at a cost of \$88, or \$0.037 per 100 pounds.

A butter churn having a volume of 300 gallons and a capacity of 100 gallons per churning, operated by a 2-horse-power motor, cost \$118.50. It is operated 88 hours per year, churning 15,000 pounds of butter at a cost of \$36.60, or \$0.002 per pound. This includes churning, washing and working the butter ready for packing.

A root-cutter with a capacity of 6 tons of turnips an hour costs \$26.30, and is operated by a 2-horse-power motor costing \$86. It is used 52 hours per year, principally during the winter months, cutting 300 tons of beets and turnips at a cost of \$35.94, or \$0.119 per ton.

A fodder-cutter, having a capacity of 3 tons per hour of dry fodder, costs \$128.10, and is operated by a 10-horse-power motor costing \$118.50. The outfit is used 88.70 hours per year, and will cut 180 tons of fodder at a cost of \$54.85, with one operative, at a cost of \$0.30 per ton.

One of the means by which the farmer may secure his electricity at a low rate is to make his consumption as nearly uniform as possible during the whole 24 hours. The cost of electricity is based on the cost of fuel or water power, attendance and the amount of capital invested in the installation, including generators and transmission system. It will be seen that if all the farmers on a line demand electricity during the same few hours of each day, larger and more expensive machinery must be installed for its generation than would be necessary if the requirements for the same amount of electricity were spread over a greater part of the day.

Consequently, by using power for food-chopping, meat-grinding, dairy purposes, wood-sawing, cooking, washing and general purposes during certain hours of the day, light for morning and evening, and pumping water for irrigation and the household during the night, the farmer may, under the direction of a central station, so consume his electricity that it may be generated at the lowest cost possible.

It is the custom of the central station concerns to deliver electricity to the consumer's premises, where usually the user installs his own distributing system through his house, barns, etc.,

inasmuch as the majority of farmers can as a rule afford to buy their own machinery, particularly the smaller sizes. In the case of large installations, however, a number of methods may be availed of to secure the benefits of such machinery without its outright purchase, usually through the co-operation with the central station concern. Many such enterprises are only too willing to furnish electric motors, and make wire installation on the farm premises — for both light and power — at a small yearly rental or on low instalment payments. In consequence, the farmer may have the cost of his machinery spread out over a number of years, the saving effected in both manual and animal labor being far more than sufficient to pay for the investment. He will eventually become the owner of the equipment, the while making a handsome profit through its use. It has already been demonstrated that farm efficiency can be accomplished in no way more advantageously than through the extension of the use of electricity on the farm.

**ELECTRIC FIELD**, any space wherein electric force exists. See **ELECTRICITY**.

**ELECTRIC FIRE-ALARM**. See **ELECTRIC SIGNALING**.

**ELECTRIC FISHES**, several quite unrelated fishes which possess the extraordinary property of communicating an electric shock to animals with which they come in contact. The organs which are the source of this power have been much studied by both anatomists and physiologists. They are in all cases — with the possible exception of *Malapterus* — formed by the modification of muscular tissue, and consist of a mass of numerous closely packed prisms, each divided into a series of compartments filled with a gelatinous substance. One surface of the fibrous discs thus formed receives a rich nerve supply and is electrically negative, the opposite surface being positive. The entire organ may therefore be likened to a group of voltaic piles. Among the *Elasmobranchii* (q.v.), many of the skates possess rudimentary electric organs, which reach a high degree of development in the torpedo and an allied genus (*Hypnos*). In these two genera the organs occupy a large area on each side of the head and the prisms are arranged vertically and are supplied by large nerves, four pairs of which arise from a special electrical lobe of the hinder part of the brain, while a fifth is a branch of the trigeminal. In the electrical catfish (*Malapterus electricus*) of the Nile, and some allied species, the entire body is enveloped by an electric layer beneath the skin and the muscles. In the electric eel (q.v.) and all other electrical fishes the organ is placed by the side of the tail and the prisms are disposed longitudinally. Not alone in structure but in the phenomena of rest and activity these organs bear a striking resemblance to muscles, which also normally exhibit weak electrical currents.

**ELECTRIC FLUID THEORY**. To explain electrical phenomena this theory was propounded in 1759 by Du Fay and Symmer. The "theory of electric fluids," as it is called, is as follows: That every body contains an indefinite quantity of an imponderable subtle fluid,

that this fluid is composed of two fluids which are self-repulsive but mutually attractive. When a body is in its natural state, the two fluids are in combination, and neutralize each other. The act of electrification consists in the forcible separation of the two fluids, whereby one is diffused over the body rubbed and the other over the rubber, one kind of electricity never appearing without an equal quantity of the other. This theory, however, must be regarded as a mere provisional conception, and not a proved scientific truth. See **ELECTRICITY**.

**ELECTRIC FURNACES**. These furnaces are devices for localizing the heat of an electric circuit and utilizing it. In the usual technical use of the term it signifies a device or receptacle in which a comparatively high temperature is developed for the purpose of effecting a chemical reaction or producing a change of state in the substance to be treated, such, for instance, as the reduction of an ore, the formation or disruption of a compound, or the fusion or volatilization of a metal or compound. Electric furnaces comprise means for developing the necessary heat at the point or points desired, and for subjecting the material to be treated, technically known as the "charge," to the influence of this heat. The several types or classes of electric furnace will be briefly described according to the principles employed. The heat development in any given portion of a circuit is proportionate to the resistance offered to the passage of the current; hence those portions of the circuit external to the furnace proper are always composed of metals which conduct the current well, and generally of copper or aluminum, whereas the resistance of those portions of the circuit in which the heat is to be localized is relatively high. These latter portions of the circuit may consist of gases, in which case an arc is formed and the localization of the heat is extreme; of substances of high melting and boiling points, in a state of fusion, when an electrolytic effect, to be hereinafter more fully referred to, usually supervenes; or of solids, such as platinum and other difficultly fusible metals, carbon, graphite and carbonaceous mixtures, or such bodies as the oxides of the alkaline earths which become conductive when heated. These three classes of furnace, wherein the heat is localized in a gas, a liquid and a solid, respectively, may be conveniently designated by the terms arc furnace, electrolytic furnace and incandescent furnace, although as will appear it is not always easy to apply one or another of these names to the actual constructions. Although electrically developed heat is relatively costly, the fact that it can be locally applied, within the interior of the charge if so desired, is an important advantage, and the utilization of the heat is often so complete that its use represents a real economy. The heat lost is that which is carried from the furnace by the escaping products of the reaction, and that which is conveyed by radiation, convection or conduction, from the walls, the electrodes and other exposed portions of the structure. Inasmuch as the exposed surfaces of a furnace are roughly proportionate to the square of its dimensions, whereas its capacity varies as the cube, it is evident that, other things being equal, the larger the furnace the less will be the percentage of total heat which is lost and the

greater will be the efficiency. This indicates the employment of large units. It is always possible to reduce the expenditure of electrical energy by making use of heat otherwise generated, such heat being employed for raising the temperature of the charge previous to its introduction into the electrically heated zone, or for heating the exposed surfaces of the furnace structure in order to check conduction from within. Furnaces in which chemical reactions are conducted, as, for instance, those in which calcium carbide is produced, often yield gaseous products which are not only themselves very highly heated, but are capable, by combustion, of further heat development. It has frequently been proposed to utilize this heat by conducting such gases through or around the incoming charge or by burning them in flues surrounding the furnace, but the greater complexity of the structure and the difficulty of purifying the large volume of dust-laden gas constitute practical difficulties of a serious nature.

**The Arc Furnace.**—When an electric arc is formed in air between carbon terminals there is observed to be a definite limit to the length of arc which can be maintained with a given current strength; furthermore this limit, which at first increases almost in proportion to the current strength, increases very slowly as the current density reaches higher values. The maximum length of the arc is therefore limited. The temperature of the carbon terminals may attain  $3,500^{\circ}$  C., at about which point, under atmospheric pressure, carbon volatilizes. The temperature of the incandescent gases of the arc is perhaps a thousand degrees higher. It follows that the arc furnace, in its simplest form, is adapted particularly for subjecting small charges to extremely high temperatures, and its value for experimental work is apparent. For use upon a commercial scale it is generally necessary so to distribute the heat from the arc that a comparatively large body of the charge may be acted upon at a given time. This result may be accomplished by establishing a plurality of arcs in adjacent portions of the charge, by exposing the charge to the heat radiated from one or several arcs not in contact with it, by causing the arc to move relatively to the charge, or by moving the charge through or past the arc. The temperature of that portion of a charge which is in immediate contact with an arc may be practically that of the arc itself and is uncontrolled; the operations for which this method of procedure is suitable and economical are relatively few. The high temperatures which the electric furnace is capable of producing have opened a new field to chemistry, but in order to insure the formation, in theoretical quantity and in a state of purity, of many compounds, a careful regulation of the temperature is essential; for the highest attainable temperatures are capable not only of giving rise to new combinations but also of breaking them down, resolving them into similar bodies or even into their elements. A single instance of the importance of heat regulation may be offered: If a mixture of sand and coke be cautiously heated in an electric resistance furnace a partial reduction of the sand occurs, and a product containing silicon oxygen and carbon and known as "siloxicon" is formed; at a somewhat higher temperature the reduction is complete and there

results an amorphous body having the essential composition of carbide of silicon and technically called "white stuff"; at somewhat higher temperature ranges this amorphous body passes into the crystalline carbide of silicon "carborundum," a compound approximating in hardness the diamond itself; and at still higher temperatures, approximating those of the arc, this carborundum is broken down, its silicon escapes as a vapor, and its carbon remains in the form of graphite. The effect of high temperatures upon reactions is twofold: in the first place the velocity of the reaction is increased, so that chemical changes which at lower temperatures occur slowly or not at all take place rapidly or even with explosive violence; in the second place new conditions of equilibrium are established, and the chemical elements, entering into that combination which, under the circumstances, is the most stable, sometimes give rise to compounds not before known. To produce a given result, however, it is usually necessary to work within definite temperature limits, and since the heat of the arc cannot well be controlled, it is necessary to govern the temperature of the charge by limiting the duration of its exposure to this heat. As above pointed out, this may be accomplished by moving the arc through or near the charge or by moving the charge through or past the arc, the duration of contact being so adjusted to the quantity of charge and to its specific heat as to bring it to the desired temperature. As a rule, however, the arc as a source of heat is both wasteful and inefficient.

**The Electrolytic Furnace.**—When a direct current of sufficient volume is caused to pass through a molten salt not only will the salt be maintained in fusion by the heat developed by its own resistance, but it will be "electrolyzed," that is to say, it will be decomposed in such manner that one of its component parts, which may be a metal, will tend to accumulate at one electrode, while another component, which was before in combination with the metal, will appear at the other electrode. The electrode at which the current is assumed to enter the molten bath, and at which the negative or non-metallic portion of the compound appears, is called the "anode," while the other electrode, which receives the positive or metallic element and at which the current is considered to leave the bath, is designated the "cathode." Thus if common salt, sodium chloride, be fused and traversed by a direct current, the negative element chlorine will appear at the anode and the metal sodium at the cathode. If the substance of either electrode be such that the element liberated in contact with it can combine with or dissolve in it, the corresponding compound or solution will be formed: If, for instance, the fused sodium chloride be electrolyzed with an anode of carbon and a cathode of molten lead, chlorine will be evolved at the anode and escape from the bath, while sodium, dissolving in the lead, will yield an alloy from which the metal sodium, or its hydroxide caustic soda, may be obtained. In electrolytic furnaces also it is essential carefully to regulate the temperature, not only because an unnecessary high temperature means a waste of energy, but because of losses arising through volatilization of the bath and the recombination of the separated prod-

ucts of the electrolysis. So important is this last factor that in certain cases, as, for instance, in the separation of metallic sodium from molten caustic soda, it is absolutely essential to the success of the process that the temperature be maintained within limits of a few degrees only.

**The Incandescent Furnace.**—This term is commonly applied to those furnaces wherein the heat is developed by the passage of the current through a body which initially at least is solid. Such body may comprise a rod or core of carbon or carbonaceous mixture; a granular bed or core consisting of fragments of coke, retort carbon or graphite; the charge itself, often admixed with a quantity of carbon sufficient for its reduction; the furnace product when this is conductive and possesses a volatilizing point sufficiently high to permit the necessary temperature to be attained; or a pyroelectrolyte, that is to say, an oxide or mixture of oxides which is normally non-conductive or substantially so, but which while remaining unfused becomes capable at temperatures considerably above the normal of carrying the current. Each of these resistance materials possesses its advantages for particular lines of work, but all have in common the advantage of permitting accurate and ready adjustment of the temperature by varying the amount of current passing. These incandescent furnaces have, therefore, the widest applicability, and in case the resistance material used is carbon the maximum temperature attainable is probably not inferior to that of the terminals of the electric arc. The above defined types are not always sharply distinct, but under certain conditions the operation proceeds under two or perhaps all three of the methods. Thus if the resistance consists of fragments of carbon, the current may traverse the interspaces in the form of minute arcs; and if this fragmentary carbon be commingled with a suitable ore or compound there may be present also an electrolytic effect; the primary fusion of an electrolyte is often accomplished by means of a resistance rod connecting the electrodes, or this fusion may be accomplished by the arc. Furthermore a given furnace structure is often capable of either mode of operation according to the character of the charge and the adjustment of the electrodes with reference thereto. The most important as well as the most characteristic applications of the electric furnace have relation to certain elements and compounds which cannot be produced directly, if at all, by other means. See ELECTRO-CHEMISTRY; ELECTROCHEMICAL INDUSTRIES.

**Commercial Furnaces.**—The carborundum furnace employs a continuous core of coke between the electrodes. This core of broken coke constitutes the resistance, and a high temperature is obtainable. The material for making the carborundum is finely divided coke, sand and sawdust. These being packed around the core, the current is turned on at about 200 volts pressure, and when the furnace heats this may be reduced to less than half the voltage. The coke core changes to graphite and the mixture into crystalline silicon carbide in from 30 to 36 hours. The great Acheson carborundum furnaces at Niagara Falls are over 15 feet long, and 42 feet cross section. For electrodes carbon rods two feet long and three inches diameter are grouped in bundles of 60. The resisting

core of coke is nine feet long and two thick. About 1,000 horse power are required to run such a furnace, and the product is about one-quarter pound of carborundum per kilowatt hour. There is a considerable by-product of graphite, and the principle of this furnace is made use of in the manufacture of graphite, for which there is an increasing demand.

For the manufacture of calcium carbide, furnaces with carbon electrodes are employed, or sometimes one of the electrodes is of metal. One electrode may be formed of a mixture of broken coke and lime in a crucible, while a carbon or a set of connected carbon rods may constitute the other electrode. Alternating current is usually employed. An arc being formed, the lime begins to give off oxygen, which combines with some of the carbon, forming carbon monoxide, which gasifies and passes away, leaving the pure calcium to unite with the remaining carbon as calcium carbide. A temperature of about 2,000° C. is desirable for the process, though calcium carbide can be formed at a considerably lower heat. The King furnace is described under ELECTROCHEMICAL INDUSTRIES.

A similar type of furnace answers for the manufacture of phosphorus; the materials supplied are phosphoric acid and coke. The phosphorus comes out as a vapor and is caught in a flue and condensed. Both calcium carbide and phosphorus may be made continuously, by providing means for feeding the furnace with new material and carrying off the product.

In the aluminum furnace a continuous current is employed, the positive electrode being at the top, so that the current may pass downward through the fused mass to the negative electrode, which may be of either iron or carbon. The liquid is thus electrolyzed on the wet principle. The metallic oxide alumina is fed into a fused mass of fluoride of aluminum and sodium (cryolite,  $\text{Na}_2\text{AlF}_6$ ), the fluoride being electrolyzed. The oxygen uniting with carbon at the negative electrode the metal collects at the bottom, and may be drawn off through a tap-hole, the process being continuous. Over 150,000,000 pounds of aluminum are annually produced by electrical furnaces in the United States, and large factories have recently been built at Whitney, N. C.

The electric furnace has been tried for smelting a great variety of ores, with many interesting results. Several concerns announce success in smelting zinc ores in the electric furnace, one being at Keokuk, Iowa, where there is cheap hydroelectric power. It is practically certain that within a few years there will be considerable electrolytic smelting in localities where electricity is obtainable in large quantity at low cost.

The smelting of iron ores in an electric furnace was begun in Italy, where Captain Stassano patented a furnace in 1898, and by 1900 ferro-alloys were being produced commercially, and to-day ferro-alloys are generally and preferably made in electric furnaces, of which 114 were known to be in operation and 30 building in different countries just before the European war of 1914. Of these 14 were in the United States, and the majority in Germany, Austria, France and Sweden. These electric furnaces do not pretend to compete with the great blast furnaces in cheap production of iron and steel,

but their product is superior in the case of alloys of known exact percentage, and the demand for such steels being constant and increasing, the future of the electric furnace is assured. As the cost of electrolytic iron becomes lowered there is a tendency to introduce the furnaces for commercial iron in regions where coal is scarce, as in California. There are large deposits of iron ore in Southern California which are liable to become of commercial importance when electrolytic reduction is better developed, as they have the advantages of cheap oil as a reducing agent.

The first electric iron-making furnace at Shasta, Cal., was completed in 1907, being of the Heroult type, 1,500 kilowatt, three-phase reduction furnace. It had to be rebuilt and rebuilt again, and was not deemed a commercial success until 1911. The furnace proper is a

well-burned lime and  $12\frac{1}{2}$  pounds of quartz. With coke at \$6 a ton and power at \$16 a kilowatt year, the cost of these items and for consumed electrodes is \$6.87 per ton of pig iron product.

New electric furnaces under construction have an average capacity of  $4\frac{1}{2}$  tons. A 25-ton furnace and another of 22 tons were completed at Bruckhausen, Germany, just before the war broke out. In 1911 Germany produced over 60,000 tons of electrolytic iron or almost as much as all other countries combined. The United States production is now (1916) nearly as large. The Heroult furnace, developed in France, is the most popular type and is used in California, South Chicago, Worcester and other places in the United States. The first Swedish furnace was the Kjellin, which was superseded by the Rochling-Rodenhauser, and

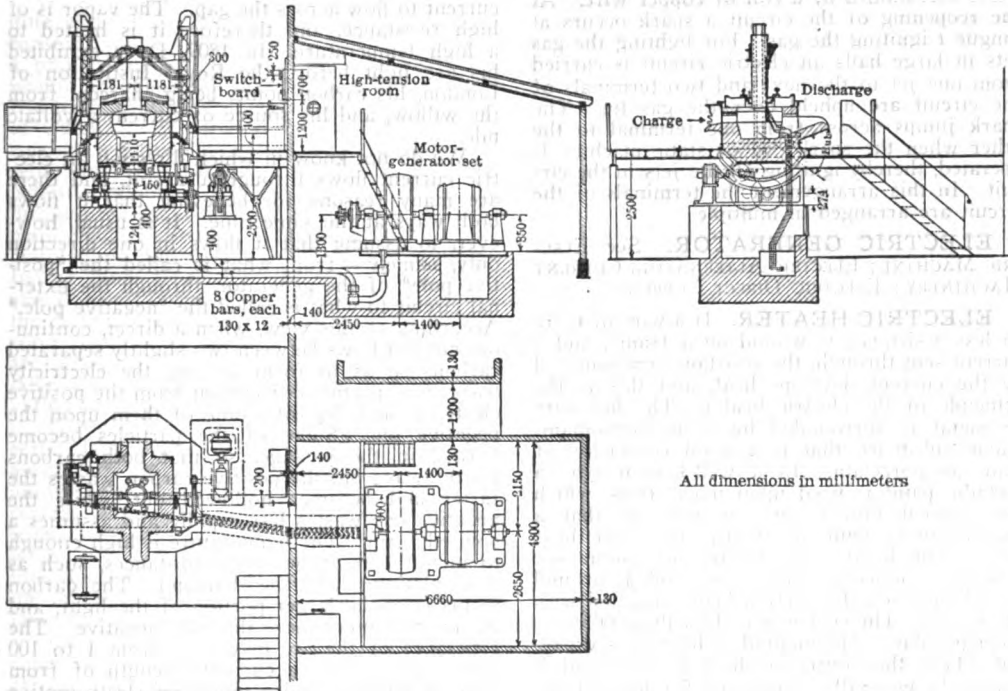

Arrangement of electric-furnace steel plant, Oberhausen, Germany.

steel shell 27 feet long, 13 wide and 12 high. The bottom slopes toward the tap-hole which is centrally placed in front. There are five 24-inch stacks, extending 15 feet above the roof. Cylindrical graphite electrodes are used one foot in diameter and four feet long. They last about 30 days, but the working is made continuous by fastening a new one to the stump of the one partially consumed. Three service transformers supply three-phase current at 40 to 80 volts to the electrodes. They are each 750 kilowatts, and are water-cooled and oil-immersed. The metal is drawn off three times in every 24 hours. It is not necessary to shut off the current during the charging, so the operation is continuous. The charging is done by cars, running to a platform at the level of the top of the shafts. A normal charge is 500 pounds of magnetite iron ore, 140 pounds of charcoal,  $3\frac{1}{2}$  pounds of

is especially adapted to refining molten metal. It is built in sizes up to 15 tons capacity, something like a great steel converter, having an enormous steel tank, mounted on rollers and tipped sideways for pouring. One of these has been installed at Landstown, Pa., and uses 300 kilowatts, furnished by a 25-cycle current at 480 volts.

The success of the electric furnace in the iron and steel industry is due to the fact that the product of these furnaces is much purer than the blast furnace, and this notwithstanding the blast furnace product has been vastly improved in purity. Pure iron is essential to making alloy steels with a known percentage of this or that other metal, required for producing certain results. For further details consult 'Electric Furnaces for Making Iron and Steel,' issued by the Bureau of Mines.

**ELECTRIC GAS-LIGHTING**, a method of igniting illuminating gas by which one or a large number of jets may be lighted simultaneously by an electric spark. In the figure a simple form of electric gas lighter is shown. A

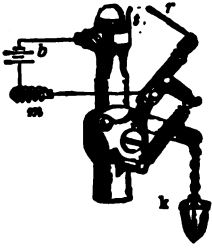

metal tongue *t*, insulated from the burner, is supported near the tip as indicated. A metal rod carried on suitable levers brushes across the tongue *t* when the knob *k* is pulled down, thereby closing and opening, as it does so, an electric circuit which includes the rod *r*, tongue *t*, battery *b*, of two or three dry cells, and a spark coil *m*, consisting of a bundle of iron wires surrounded by a coil of copper wire. At the reopening of the circuit a spark occurs at tongue *t* igniting the gas. For lighting the gas jets in large halls an electric circuit is carried from one jet to the next and two terminals of the circuit are upheld over the gas tip. The spark jumps across from one terminal to the other when the spark coil or static machine is operated, thereby igniting all the jets in the circuit. In this arrangement the terminals of the circuit are arranged in multiple.

**ELECTRIC GENERATOR.** See **ELECTRIC MACHINE**; **ELECTRIC ALTERNATING CURRENT MACHINERY**; **ELECTRIC DIRECT CURRENT**.

**ELECTRIC HEATER.** If a wire of more or less resistance is wound on a frame, and a current sent through, the resistance encountered by the current develops heat, and this is the principle of the electric heater. The hot wire or metal is surrounded by some non-inflammable substance that is a good conductor of heat, as porcelain. In a well-known type a metallic paint is fired upon mica strips, which are formed into groups or sets, so that a heater can be built up of any size from these units. For heating an electric car some six sets of conducting wires are coiled around porcelain tubes, the current being supplied with the motor. The cost is stated at about 60 cents a car per day. The method of heating is wasteful where the source of heat is coal, and it cannot be generally substituted for house heating; but it is excellently adapted for small individual heaters, where the cost is less important than the convenience, as for flatirons, kettles, saucepans, dinner plates, soldering tools, toasters, dishwashers and cookers. The industry of manufacturing such small heaters already runs into several million dollars annually in the United States. A recent new use for the electric heater is the stimulation of petroleum wells that are running dry. Heating coils are lowered into the well to melt out the heavy oil accumulation and cause it to flow freely. In the manufacture of armatures, time has been reduced by the use of electrically heated ovens to dry out the moisture. The temperature can be regulated so accurately that there is no danger of melting the solder. In enameling iron the electric heater has also found a field of usefulness, because it maintains a high and uniform heat. The same quality of uniformity has caused the manufacturers of linotype machines

to make an electric heater for their melting pots.

**ELECTRIC INDUCTION.** See **INDUCTION**.

**ELECTRIC LIGHTING.** In 1800 Sir Humphry Davy discovered that if two pieces of carbon are joined by conductors to a source of electric current, and such pieces momentarily touched together, so that the circuit is complete and a flow of current established, upon their separation for a short distance, a flame is emitted, and, if the current be sufficiently powerful, this flame will continue, the carbon points will become intensely hot and emit a brilliant light. In separating the carbon points, the extra potential induced by the self-induction of the circuit is sufficient to leap the small air gap and thereby vaporizes a small quantity of carbon. Carbon vapor, being a conductor, allows the current to flow across the gap. The vapor is of high resistance, and therefore it is heated to a high temperature. In 1809, Davy exhibited his arc light before the Royal Institution of London, his carbon points being charcoal from the willow, and his source of current a voltaic pile.

We do not know in which direction an electric current flows through a circuit, and there are many reasons for believing that it flows both ways at the same time. It is usual, however, to assume that it flows in one direction only, namely—from what is called the “positive pole” of the generator, through the external circuit to what is called the “negative pole.” According to this view, when a direct, continuous current flows between two slightly separated carbons so as to form an arc, the electricity tears away particles of carbon from the positive electrode, and deposits some of them upon the negative one. Some of the particles become burned in the passage, so that both carbons waste away; but the positive carbon wastes the faster and becomes hollowed out, while the negative one wastes less rapidly and assumes a pointed form. The temperature is high enough to melt the most infusible substances, such as flint, platinum and the diamond. The carbon points emit the larger portion of the light, and the positive point more than the negative. The resistance of the arc may vary from 1 to 100 ohms. It requires a current strength of from 3 to 10 amperes, and a minimum electromotive force of 40 to 50 volts, to maintain a satisfactory lighting arc.

Davy used wood charcoal for his electrodes, and while they were of excellent quality, on account of their softness they lasted only a short time. As the arc would burn away, it was necessary continually to adjust them, or the arc would go out. Therefore it was found necessary to have carbons of sufficient density to last a reasonable time, and purity so that the light might be steady. Also to have a mechanism automatically to feed the carbons, and keep them a constant distance apart, as well as automatically bring them together in order to start the arc. Refined petroleum coke, ordinary gas coke, or lamp black is now taken for the base material, thoroughly ground and mixed into a stiff paste, dried and carbonized out of contact with the air. A very hard and uniform carbon is thus obtained, in any desired size, the usual length being 12 or 14 inches, and diameter



7/10, 1/2 or 5/8 inch. Broadly, the lamps may be divided into two classes: series and multiple; each system into two sub-divisions: the open and the enclosed.

The electric energy loss from the point of generation to the lamp may be expressed,  $W = C^2R$ ; where  $W$  is energy in watts, dissipated as heat in conductors,  $C$  is current in amperes, and  $R$  is resistance of circuit in ohms.

From the equation it may be noted that the loss is in proportion to the square of the current, so long as  $R$  remains constant. Therefore, in distributing electric energy to a number of arc lamps, it is more economical to keep the current constant, and have the lamps joined in series.

Two types of lamps were evolved to meet these conditions as well as a generator to keep the current at a constant quantity, (1) the differential lamp; (2) the shunt lamp. In the differential lamp, the current must remain at a constant value. The main current is carried to a pair of lifting magnets, over which, but wound in opposition thereto, is a coil of high resistance called the shunt magnet, the terminals of which are cut around the arc itself. When current is thrown into the lamps, the main current pulls the carbons apart until sufficient potential is obtained at the arc to force current through the shunt magnet, which neutralizes the main magnet, thereby securing a balance, and maintaining the potential at the arc constant. In the shunt type lamp, the shunt magnet circuit is so arranged as to trip the clutch holding the carbon rod, thereby allowing the carbons to come together, should the potential around the arc exceed the predetermined amount. This lamp will burn upon any current strength, providing it is enough to operate the main magnet.

The conditions common to both types of series lamps are: (1) As the carbons burn away, they must be fed down gradually and not allow the potential around the arc to exceed a certain voltage. (2) Should the carbon rod stick, or anything happen to disarrange the lamp, protective devices called cut-outs come into operation, so the lamp will not be burned up, or the circuit opened. These open types of lamps are now practically obsolete.

**The Enclosed Arc.**—The open arc was superseded by what is called the enclosed arc. It was discovered that if the arc be surrounded by a narrow, nearly air-tight globe, it greatly modified the character of the light and the carbon would last much longer. The small globe prevents the air from having access to the carbon, thus diminishing its oxidation. When the lamp is started, it soon exhausts the oxygen contained in the globe, and if the globe is tight, the carbons will last from 80 to 175 hours. This type of lamp held the market for some years and then the flame arc lamp became popular. This was based on the principle of introducing oxides into the carbons, to secure an increased flame arc, somewhat as the Welsbach mantles increase the luminosity of a gas-flame. Calcium chloride, and the oxides of iron, titanium, chromium, etc., were employed with more or less success. In the making of the carbons (which are commonly of petroleum coke ground fine and mixed with tar, forced through dies and dried), the metallic oxides are either mixed with the mass or introduced in a metallic core. An increased voltage is required, as

the electrodes are drawn farther apart to get a long flame; in some forms, as the magnetite lamp, the lower positive electrode is simply a permanent knob of copper, while the upper negative electrode carries the mineral salts. Such lamps give a large body of arc or flame and do not burn a crater in the carbon, but consume a comparatively flat surface when directly opposed. In one form two carbons are employed, positioned like the sides of a V. The quantity of vapor given off by the flame arc lamps necessitated an open globe at first, but later it was found possible to draw out the vapor by a draft and largely to enclose them.

**Glowers and Vapor Lamps.**—The Nernst lamp was the next popular favorite. Instead of carbons it employs what is known as a glower, this being a little tube, something over an inch long, and made of the oxides of thorium, zirconium, yttrium, etc., mixed with a binding paste and baked into a condition resembling porcelain. This tube is coated with oxides and provided with platinum terminals. On passing a current it emits a soft white light. The glower has to be heated to start it, and a coil called a heater is provided for the purpose; there is also a "ballast" or resistance to avoid overheating. After the lamp glows it provides its own heat and the coil is automatically switched out. These glowers are of about 50 candle power and when more light is demanded, several glowers are included in one lamp. The life of a glower is about 600 hours on direct circuit and 400 on alternating current, thus far outclassing the arc lamps. They are made for both 110 and 220 volt circuits.

A distinct advance in durability and long life of the working parts of an electric lamp has been scored by the so-called vacuum tube lamps, in which a long tube is exhausted of air and then supplied with a small quantity of metallic vapor, as of mercury, which lights up when an electric current is passed through, emitting a very soft diffused light, that does not trouble the eyes with its glare, as is the case with most strong lights. The Cooper-Hewitt mercury vapor lamp was first tried out in 1903, at the office of the *Evening Post*, in New York, and has since been largely introduced for general indoor use. The typical house-lamp employs a tube from 20 to 50 inches long and of perhaps an inch diameter, backed by a metallic reflector. At one end of the tube is an iron mercury cup serving as the positive electrode, while a glass bulb at the other end is the negative terminal. Platinum wires supply the current. The air is exhausted from the tube, which is then sealed. When the current flows, a little mercury is allowed to vaporize in the tube and a soft greenish-white light of great intensity is obtained. Induction coils are placed in the body of the fixture, also an adjuster resistance, shunt resistance and cut-out. Pulling a hand-chain operating a switch starts the light, and if the current fails and it goes out through any accident, an automatic device can be had for relighting it. Lamps are made for both direct and alternating current. A tube gives normally 3,750 hours' service, or the equivalent of 10 hours a night for one year. These Cooper-Hewitt mercury vapor lamps are also manufactured with tubes of a great variety of lengths and doublings, for use in factories, mills, machine shops, stores, photograph and moving-pic-

ture studios, etc. They bring illumination wherever it is wanted commercially, closely reproducing daylight conditions and obviating strain on the eyes from glaring lamps. For outdoor use the Cooper-Hewitt quartz lamp is supplied, which employs a short tube of fused silica (or quartz glass), permitting a high temperature and stronger current for brighter illumination, as in railway yards, parks, etc. Such lamps have lasted for months without attention.

The Moore vapor tube glow lamp is manufactured in various forms, and is much valued for matching colors, owing to its close approximation to daylight conditions. By the employment of different vapors it can be made to yield blue, white, yellow or rose light. It requires renewal of carbon dioxide after 1,000 hours' use, but the tubes will last four or five thousand hours. It is run on 110-volt circuits at 23 amperes.

**The Incandescent Lamp.**—The great objection attending the use of the arc system of lighting was that the light was too intense for most purposes required inside. It could not be readily subdivided. From the earliest days of electric lighting, various inventors endeavored to subdivide the light. The idea of using continuous conductors, instead of the discontinuous as in arc lighting, was tried in almost every conceivable form. These conductors were to be heated to a white heat and rendered incandescent by the passage through them of an electric current. The great difficulty arose from the fact that to give useful results, the working temperature of the material was so near its melting point, that any slight increase in the current would destroy the conductor. In 1878 a great improvement was effected in the platinum filament incandescent lamp, which was obtained in a condition safely to withstand a much greater current strength. The filament was placed in a vacuum, and slowly heated therein. The occluded gases were slowly liberated, and it was discovered that if a high vacuum were maintained and the wire raised to a point just below its melting point, the point of fusion was raised, and the physical character of the metal was considerably changed. This lamp, however, was never a commercial success.

Various inventors experimented with the platinum lamp, enclosed in vacuo, but the greatest improvement was made by the substitution of carbon filaments for platinum. This was done by an American, J. W. Starr, who employed plates inside a glass vessel containing a Torricellian vacuum. Many patents were taken out in all countries for lamps of various types, but none were commercially successful; many, perhaps, for the want of a cheap method of generating the electrical energy, as well as through fault of the lamp itself.

The advent of the first successful incandescent lamp dates from about 1879, when Edison gave us the carbon incandescent lamp, and from that time the growth of the incandescent electric lighting industry has been extremely rapid.

Every such incandescent lamp consists of a carbon filament attached to two platinum wires, a glass bulb in which a vacuum is formed, and finally a threaded base attached to the bulb, and designed to hold the lamp in its socket.

The following is in a general way the method by which the lamps are made. The bulbs are

blown at the glass factory whence the manufacturers obtain them directly. The first manipulation consists of preparing them for the filament. The nature of the filament varies with different systems. There are three kinds employed. Some (Swan) employ cotton threads; others gelatine or vitrified cellulose (Khotinski Lave-Fox); and others use vegetable fibres (Edison-Siemens). Finally, some employ a natural fibre submitted to a chemical process (Langhans Cruto Seel). Form is given to the filament according to its nature, either by means of a die, or between cylinders, or by cutting it out while in a plastic mass. The fibre thus obtained is transformed into compact carbon by prolonged baking at a high temperature in a crucible or by heating with the electric current itself. To give the filament homogeneity and the desired resistance a layer of carbon should be deposited on its surface. This deposit is affected in many ways. A very simple method termed "flashing" consists in immersing the filament in petroleum and raising it to a red heat in that liquid. The filament being cut to the desired length, Edison clamps the carbon with platinum wires and covers the points of attachment with a layer of electrolytic copper; Lave, Fox and Swan deposit a greater quantity of carbon there, while other manufacturers employ a special cement or solder. The filaments may be fixed in the bulb in two ways: either the two wires are fused into a piece of glass called the budge, which is next fused into the neck of the bulb; or else the wires are fixed separately on the edges of a glass socket, which is then fused into the bulb. A small tube is also fused to the top of the bulb in order to provide for the production of a vacuum. The exhaustion of the lamps takes place by means of mercury pumps. The vacuum obtained, the lamp is tested. Then the luminous intensity and the resistance when cold are measured. The dimensions of the filaments vary with the luminous intensity of the lamp; they should be proportionately greater as the normal intensity of the lamp is higher. These dimensions depend also upon the specific resistance of the carbonized substance. As to the form of the section of the filament, the circular one is preferable because it presents the minimum resistance for a given surface.

The reason for withdrawing the air from the bulb is that if the filament were heated in the air the oxygen of the air would combine with the carbon, causing combustion and consequent destruction. Even enclosed as it is in a vacuum the filament is slowly destroyed by the intense heat at which it is operated. Aside from the advantage named is the fact that there is no heat-conducting medium between the filament and the globe, practically all the heat that is emitted being that which radiates from the filament (a small amount is lost by conduction through the leading-in wires). If there were any gas or vapor within the bulb it would conduct additional heat to the glass walls, and also dissipate heat by convection, so that with a given current in a given filament the temperature of the filament would be reduced, and, therefore, less light would be obtained. The destruction of the filament referred to is not due to combustion because as just explained there is no oxygen left in the bulb. There is a disintegration of the filament by some process that has

never been positively identified or explained, the results being that impalpable particles of carbon are deposited on the inside surface of the bulb, causing a gradual darkening of the glass that is readily discernible.

The leading-in wires are made of platinum because that metal has the same coefficient of expansion by heat as that of glass. Were the coefficient different, small cracks would form in the bulb and the vacuum would be spoiled. Carbon is an exception to the general rule that almost all conductors increase in resistance when the temperature is raised. Its resistance decreases rapidly with an increase in temperature up to the red point. Thereafter, up to the white, the resistance decreases more slowly. The ordinary carbon filament, when at its working point, has about one-half the resistance as when cold. The standard filament gives out a mean illumination of 16-candle power at right angles with the axis of the lamp from base to top.

The power required for the usual 16-candle power standard lamp varies from 50 to 64 watts, depending upon the temperature at which the filament is operated. The higher the temperature of the filament the higher the efficiency in watts per candle power, and also the shorter will be the life. The life of the filament in this way limits the efficiency of the lamp. The candle power of the incandescent lamp may be greatly increased by simply increasing its filament temperature by the simple expedient of increasing the current, but thereby its life is shortened. The increase in candle power is not directly in proportion to the increase in current but in a considerably higher ratio.

It is important to maintain the potential on the terminals of an incandescent lamp at the normal working point. Any slight excess materially shortens its life. The resistance of an incandescent lamp filament is much lower when hot than cold, approximately in the ratio of two to one; that is, the resistance is twice as high cold as when hot when at normal burning temperature. The illumination is rated in candle power and power consumed in watts per candle measured when the lamp is giving its rated candle power, but this condition is not obtained with any incandescent lamp through a large portion of its active life. When a new lamp is placed in circuit it will usually give the full candle power or a trifle more at the start, and the candle power will rise to a value from 5 per cent to 11 per cent higher than the rating. It soon, however, begins to fall off with a constant diminution up to the breaking point.

The rise and fall of candle power are due to changes in the structure of the filament. The resistance at first decreases, allowing more current to flow and consequently higher temperature and more light. This is indicated by the rise of the curve from 16.2 candle power to 17.3 candle power during the first 50 hours. Then the diminution of resistance ceases and is followed by the gradual wasting away of the filament, which causes a gradual increase in resistance, by reducing its cross section. The current thus gradually falling off, taken together with the decreased surface of the filament and the deposit of carbon upon the globe, causes the fall in candle power indicated. The decrease in candle power is not directly proportional to the decrease in current, thus the energy per

candle power increases rapidly after the first few hundred hours.

**The Tungsten Lamp.**—The tungsten filament has revolutionized the incandescent lighting industry and is reducing the use of arc lamps. The carbon filament is rapidly going out, and the old-fashioned arc lamps are being replaced either by groups of tungsten lamps or Nernst or vapor lamps. The tungsten filament has a life of 1,000 hours, and some have been made of twice that durability, whereas 125 to 200 hours is long for other filaments and arc lamps. The tungsten also has the advantage of diffusing the light more, there being more turns in the filament, and it is closer to daylight in its coloration. The tungsten is a truly automatic light, requiring no attention beyond an occasional dusting. Tungsten is not so rare a metal as once supposed, and its great resistance to heat—it melts at 3200° C.—renders it a most fit metal for filaments. At first it was found exceedingly difficult to form it into the minute diameter wire form needed. It is exceedingly brittle and fragile, and early attempts to draw it through fine dies, such as are used for making the most delicate strands of copper and steel wire, were failures. Kuzel solved the problem by making a solution of tungsten, evaporating the surplus moisture and squirting the residuum through a die, getting a thread which would bear handling. Such a filament is "flashed" in a mixture of steam and hydrogen, and as the steam decomposes the oxygen unites with the carbon of the filament. Later a method of drawing the metal was worked out successfully and is preferred to the squirted film. The character of tungsten is such that a very long and frequently lapped filament is required to give the necessary light. This is an advantage, reducing the glare.

In recent tungsten lamp practice nitrogen gas is introduced in the bulb after extracting the air as fully as practicable. It has been demonstrated that the pressure of the gas retards the wasting of the filament, more than offsetting the heat lost by its introduction to the bulb. As tungsten lamps can be made of 1,000 to 2,000 candle power, and show a life of 1,000 to 2,000 hours, they have naturally become very popular.

**Wiring and Fixtures.**—The building regulations of all large cities contain more or less stringent regulations as to the wiring of buildings, the result of somewhat numerous fires caused by careless wiring in the early stages of introducing electric lighting. Cables carrying street wires are now abundantly insulated, and the individual wires entering buildings are carefully insulated and protected from accidental abrasion. At the point of entering a building, a switch-box is usually placed, with accommodation for one or more fuse-wires. These are short connections made of easily fusible wire, as a mixture of lead and zinc, so that when by accident a strong current reaches the switch, the fuse is instantly burned out, and the current can go no further, having no wire conductor. Wires for incandescent lighting are usually covered and boxed in, under certain regulations of safety, and led to the various points of use—to ceiling fixtures, pendants, electroliers, brackets, portable lamps, etc. The pendant, with flexible cord, that can be swung to any convenient point within its radius, is easily the

most popular lamp. The modern idea of interior lighting of dwellings involves the use of a semi-transparent inverted half globe, as of thin porcelain, within which the light is hidden, casting its full glare upward toward a white ceiling, from which a soft radiance is reflected downward over the surroundings. This plan diffuses the light in a most acceptable manner.

The low value of the common radiants is due to the fact that they are based upon the incandescence of carbon.

If the conversion of coal into light is through the medium of the incandescent lamp, we throw away 95 per cent of theoretical energy, and secure as light only 95/100 or practically 1 per cent of the energy of the coal.

However, the incandescent light is almost a perfect light. Since it gives off no waste products of any kind, it has no deleterious effects upon the atmosphere of the rooms or buildings in which it may be utilized. Its light is white, soft and brilliant, yet not dazzling. The lamp itself is rather ornamental than otherwise, and lends itself readily to external ornamentation without danger of fire, since of course it gives off no flame. Nevertheless, by way of caution it may be noted that, comparatively insignificant as is the heat which the incandescent lamp gives out through the glass bulb, it cannot be allowed to rest for an undue time in touching proximity to inflammable materials, since experiments have shown that when such a lamp is encased in two thicknesses of muslin for about six minutes, and fresh air is admitted to the interior, the muslin has burst into flame. Again, an article of celluloid pressed against the lamp for three minutes has ignited; and a newspaper, under similar conditions, ignited in three-quarters of an hour.

**ELECTRIC LOCOMOTIVES.** See TRACTION, ELECTRIC.

**ELECTRIC MACHINE, or Dynamo Static Machine** (now extensively employed in therapeutics), for exciting electricity by friction or by static electric induction, as distinguished from dynamo electric machines in which electricity is excited by cutting magnetic lines of force. The excitation of electricity by friction was observed by the ancients, and the word electricity is derived from the Greek word *electron*, signifying amber, in which the attracting power of electricity after friction was first noticed. See ELECTRICITY, FRICTIONAL.

It was subsequently found that a glass rod or a rod of sealing wax also possessed this electrical property when rubbed. Later on, other methods of exciting static electricity, such as by the electrophorus, were discovered. Such methods were, however, slow and laborious and better devices were sought for, resulting in the development of two general types of dynamo static machines, namely, frictional machines and induction machines, the first representing the rubbed glass rod or wax type; the second, the electrophorus type. These machines provided means whereby the rubbing and the induction might be performed continuously and mechanically.

**Frictional Electric Machine.**—The first continuous frictional machine, due to Nairne, consisted of a glass bottle, or hollow cylinder, mounted on a horizontal axis, well insulated, and turned by a winch or handle on suitable

supports. (See Fig. 1). On one side of the cylinder and pressing firmly against it, is placed the "rubber," a cushion of leather, *c*, stuffed with horse-hair, and sometimes faced with amalgam. From the upper edge of the cushion a silk flap, *s*, passes over the cylinder, reaching half way round. A brass cylinder, or a wooden cylinder plated with metal, *p*, termed the prime conductor, supported by a glass or ebonite rod, *r*, is placed as shown. A metallic comb is attached to the left end of the prime conductor, as indicated in figure.

Before the machine is set in operation an amalgam of zinc and tin or other suitable metals, is sprinkled or pasted on the surface of the rubber. When the cylinder is turned electric sparks are seen and heard to play on the cylinder from the edge of the flap, negative electricity being accumulated on the amalgam surface and positive electricity on the surface of the cylinder, due to the friction between the glass and the amalgam coated surface of the rubber. As the cylinder is a non-conductor of

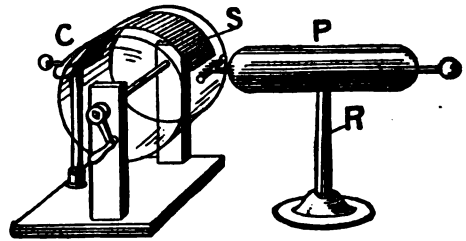

FIG. 1.—Cylinder Frictional Machine.

electricity this positive charge is held on its surface until the cylinder in revolving brings it beneath the comb, where it acts inductively on the prime conductor, *p*, attracting negative electricity to its near end and repelling positive electricity to its far end; the negative electricity escaping across the points of the comb as an electrical breeze, or brush discharge, uniting with and neutralizing the positive electricity on the glass cylinder opposite the comb, which portion of the cylinder is then ready to take a positive charge as before when it again reaches the rubber. When the prime conductor by these successive charges of positive electricity has attained a high potential, sparks several inches in length will jump from its far end to the hand or any other ground connection. To obtain a continuous supply of electricity from the prime conductor, *p*, it is necessary to connect the rubber, *c*, to the ground, which is usually done by allowing a metal chain attached to a steel plate on the back of the cushion to lie on the floor or table, this permitting the negative electricity excited in the rubber to escape to earth. In this way also a negative stream of electricity may be drawn from the machine. The use of the amalgam on the rubber has the effect of largely increasing the conductivity of the cushion, and also provides a substance, *b*, between which and glass the surface friction for the exciting of static electricity is greater than that between leather and glass.

The quality of the glass used in electrical machines is important, that containing most silica, such as the material from which ordinary pale green bottles are made, being most suitable for this purpose.

**Plate Electric Machine.**—This is another form of the frictional machine. The principle of its operation is the same as that of the cylinder machine just described. It consists of a circular plate of glass, or ebonite, *E*, Fig. 2, in place of the cylinder. Two sets of rubbers, *s, s*,

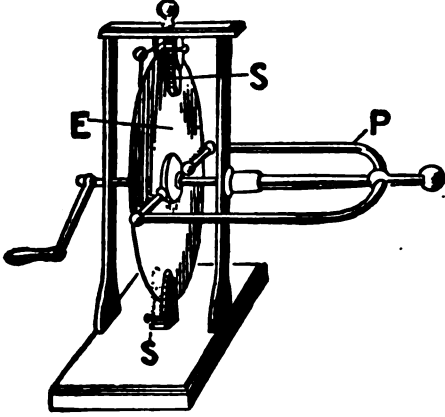

FIG. 2.—Plate Frictional Machine.

are placed on opposite sides of the plate, and as the plate is rotated positive electricity is developed on the glass, and is collected by the prime conductor, *P*, virtually as in the case of the cylinder machine.

**Static Electric Induction Machine.**—These machines depend for their action upon static induction as exemplified in the case, for instance, of the electrophorus which may be briefly described here.

**Electrophorus.**—A simple electrophorus consists of a cake of resin or vulcanite 12 or 15 inches in diameter and one inch thick, resting on a tin or iron plate. A disc of metal, termed the cover or carrier, somewhat smaller than the cake of resin, is provided with an insulating handle. When the cake is rubbed with dry flannel it becomes negatively electrified. If now the cover be placed on the cake, its positive electricity is attracted to the side of the cover next the cake. The electric charge on the resin is not discharged into the cover, however, because, on account of the slight accidental irregularities of the two surfaces, the cover will be in actual physical contact with the resin at only a few points,—perhaps at not more than three. The electricity residing in the resin at the points of true contact will be discharged, but not that at other points, because the resin is a non-conductor, and so its electricity cannot pass directly to the covering plate by conduction. Now if the cover be touched by the finger, its negative electricity will escape to earth. If now the cover be lifted from the cake it will contain free positive electricity which may be used for charging a condenser or Leyden jar. The cover may again be placed on the cake and the foregoing process may be repeated a number of times before the charge in the resin will be entirely exhausted. The cake when electrified, with the disc in its place, and undisturbed, will retain its charge for weeks.

A number of induction machines based on the foregoing principle have been devised, among the best known being the Holtz and the Wimshurst, which are sometimes termed continuous electrophori.

**Holtz's Electric Induction Machine.**—This consists of two glass plates or discs about two feet in diameter, placed side by side and separated by a very small air space. One plate is fixed; the other is rotated, the fixed plate being slightly larger. The moving plate is mounted on a well-insulated axle. On diametrically opposite points of the fixed plate there are two sector-shaped holes or windows. On the back of the fixed plate, at the windows, are glued paper inductors or armatures, blunt tongues from which they are caused to pass through the windows until they nearly touch the moving plate, which must be rotated in the direction opposite to that in which the tongues point. Opposite the inductors there are placed metal combs attached to brass rods or electrodes, which carry brass balls that at their terminals are movable to and from one another. In starting the machine the two balls are brought together and a negative charge from a rubbed ebonite rod is given to one of the inductors; then when the plate is rotated and the balls are separated, sparks jump across the space. The action of the machine is very complicated and need not be gone into here further than to say that in effect it is virtually similar to that of the electrophorus, the initial charge imparted to the armature inducing opposite electricity in the rotating disc, which in turn delivers a charge to the metal comb, which charge by successive additions as the disc rotates is augmented until it attains a potential of 50,000 volts and more. These discs are rotated at a speed varying from 120 to 450 revolutions per minute. See ELECTROTHERAPEUTICS.

**Wimshurst's Influence Machine.**—This machine, due to Mr. James Wimshurst, is one of the most efficient and reliable of the induction electric machines. It consists of two glass discs, which in practice have varied in size

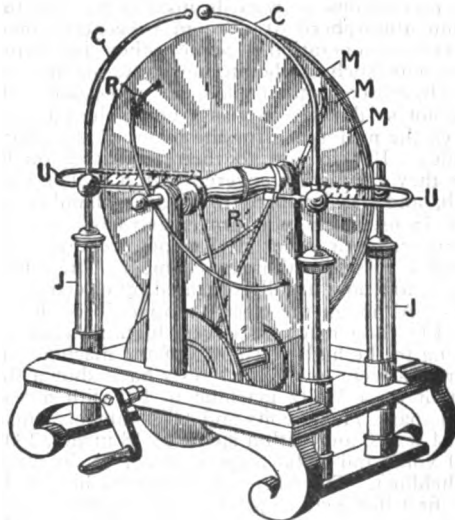

FIG. 3.—Wimshurst Electric Machine.

from 14½ inches to 7 feet in diameter. These discs suitably mounted on insulated axles are placed side by side and both are rotated, but in opposite directions. On the outer surface of each disc thin metal strips, or sectors, *M*, are glued, as indicated in Fig. 3. Two adjustable

metal "neutralizing" rods, *r*, *r*, terminating in small brushes that glide over the metal strips, are supported as shown, at oblique angles to one another; one opposite each disc. *U*-shaped collectors, *u*, *u*, carrying metal combs, diametrically opposite to one another, are metallicity connected to the electrodes or prime conductors, *c*, *c*. These collectors are supported on metal rods that rest in what are practically Leyden jars or condensers, *j*, *j*. The best position of the brushes on rods, *r*, *r*, relatively to each other and to the combs is microphone, found by actual test to be virtually as shown in the figure.

The object in employing condensers, *j*, *j*, is to add capacity to the prime conductors, thereby increasing the amount of electricity that can be accumulated, and hence increasing the energy of the discharge, and this use of condensers is common to all static electric machines. The action of this machine in operation is also complicated. The Wimshurst machine is self-exciting, that is, it starts without any externally applied electric charge, as is requisite with the Holtz machine. It has been thought that the initial charge is due to the friction of the air in the space between the two oppositely revolving plates, this space not exceeding one-eighth of an inch. Apparently the metal sectors are the equivalent of the inductors in the Holtz machine; the neutralizing rods serving to allow the repelled electricity in one sector to escape to a diametrically opposite sector on the same plate, where it in turn acts inductively on the opposite sector on the opposite plate, the free electricity when it reaches the collectors being carried off as a discharge by the prime conductors. Frequently a small Wimshurst machine is used to excite a larger Holtz machine.

All static electric machines, owing to the high potentials which they develop, require extra precautions as regards insulation, even the damp atmosphere of a room preventing their successful operation. Some other insulating materials, such as ebonite and gutta-percha, are less hygroscopic than glass, but these materials are not so durable as glass; hence the latter is given the preference for the plates of these machines. But to add to their insulating qualities they are always covered with a shellac varnish, and are enclosed in a glass chamber or box from which moisture is extracted by sulphuric acid or other desiccators, contained in suitable vessels within the chamber. These machines are now usually operated by electric motors. Although the electro-motive force developed by these machines is very high, the current, owing to the high resistance of the machines, is comparatively low. Thus tests have shown the output of a Holtz machine to be, with a six-inch spark, 71,000 volts and .00048 ampere, equal to 34 watts, and with a spark of 18 inches, 180,000 volts and .0002 ampere, equal to 36 watts (Sheldon). The efficiency of the machine is, in the first instance, 27 per cent, and in the second 19.5 per cent. The current is approximately directly proportional to the rotation of the plates. The Holtz machine and others of its type are continuous current machines, and at a given speed their current output and electro-motive force are constant. By efficiency is meant the energy given out by the machine as compared with that expended in driving it. (The

efficiency of a dynamo electric machine is often over 90 per cent.) The electric power expended in driving these machines, under test, was, in the first case, 126 watts, and in the second case, 180 watts. Later tests by Sheldon on other static machines show an efficiency of 40 to 46 per cent, with an output of 10 to 12 watts.

To increase the volume of current from static electric machines, the number of plates is increased. Hence machines of the Holtz and other more or less similar types are constructed with from say 6 revolving and 6 stationary plates to 16 revolving and 16 stationary plates, or more as may be desired. In many cases the stationary plates are square or oblong sheets of glass. For therapeutic purposes, machines, giving at least a 12-inch spark, are considered advisable. Plates made of mica are also used, but with some doubt as to their durability. See ELECTROTHERAPEUTICS.

WILLIAM MAVER, JR.,

*Consulting Electrical Engineer.*

**ELECTRIC MICROPHONE.** The principle of this instrument was discovered by Prof. David E. Hughes, an American resident in London, who announced the discovery in a paper delivered before the Royal Society, London, in 1878. The microphone, as the name implies, largely amplifies sounds. It consists of a vertical carbon pencil pivoted loosely at both ends in solid carbon receptacles which are fastened to a thin sounding board, which board is suitably upheld by one edge on a solid block or base. When the carbon pencil is made part of an electric circuit in which are also a small battery and a telephone receiver, sounds are many times amplified; even a small cotton ball dropped on the block is heard in the telephone like a bullet falling on the floor. A number of theories have been advanced to explain the action of the microphone; one, adopted by the courts in this country in a case in which the validity of the Berliner telephone transmitter was an issue, being that the action is due to the remarkable effect of sonorous vibrations in varying the electrical resistance at a loose contact between solid electrodes. The most common form of carbon telephone transmitters in use to-day are varieties of the microphone. It may be added that Professor Hughes gave this instrument to the world gratis. The principle of the microphone has also been utilized in a stethoscope and in a telephonic relay.

**ELECTRIC MOTOR.** The electric motor is simply a dynamo reversed, a machine for transforming electrical energy into mechanical power. It takes its power from off a wire, as sent by a dynamo from the source. To understand the technique of its construction and operation, consult the articles on ELECTRIC DIRECT CURRENT; ELECTRICITY and ELECTRICAL ALTERNATING CURRENT MACHINERY. The small electric motor has displaced the steam engine in a great many uses, and continues to supplant it. In 1909 there were more than half a million small motors made for manufacturing establishments in the United States, with a total horse power of nearly 3,000,000 and a valuation of \$32,000,000. More and more power is being produced in large plants utilizing some waterfall to rotate dynamos, and sending out current, much of which is used for

small electric motors, driving individual machines. Users of machinery in almost all lines now accept it as the best practice to equip all large machines with individual motors, and in this way not only make their operation independent of other machines, but also save the expense of surplus power and of running shafting and belts when the machines are idle. While electric motors have cost more in some cases than steam or gas engines, and while the charge for electric power in many localities is higher than for direct steam power, yet the convenience and the doing away with cumbersome overhead shafts and belts has more than offset these. The individual motor permits machines to be located without reference to shafting lines, and makes for greater efficiency and output. With each added machine a new motor comes, and there is no throwing out of central engine plants to make way for larger. The small electric motor may be built in as a part of the machine, or it may be bolted to the floor or ceiling. It may be direct-connected if the speed of the machine is appropriate, or it may be connected by reducing gears, rendered nearly noiseless by introducing rawhide. Belt connection is often used direct or through cone pulleys, and where the power transmitted is light, a friction connection is made satisfactory by covering the smaller of the opposed pulleys with a leather face. Where machines are small it is common to group them for motor-driving; four or six machines will all be coupled to one motor, conveniently located in the centre of the group.

Manufacturers wind motors in an almost infinite number of ways to suit an endless variety of conditions. By placing resistances in the shunt circuit, a considerable variety of speed is permitted. For printing presses a motor is made with a continuous current transformer of variable ratio. This permits a slow speed without loss, as a small current at full pressure is instantly convertible to a large current at low pressure. Continuous current series motors are preferred when the work is irregular, as in starting under heavy load, as with a crane-hoist, or when encountering extra load from friction or dampness, as with cotton spinning machines on a day of high humidity. Single-phase alternating current motors have special uses, but are not well adapted to sudden changes of load. Motors that are both shunts and series wound are in large demand. This type is used on passenger elevators. The driving drum that carries the wire rope that hoists and lowers the elevator is commonly driven by this type of motor. To secure the needed gear reduction without grinding noise, a steel worm and gun-metal spur gear are run in oil. When the operator pulls the rope or lever in the elevator he turns the starting switch or controller on or off. A hand-brake on the motor shaft guards against racing, and is normally held out of operation magnetically. Thus if the current fails the brake slows up the elevator. An automatic switch is placed to shut off the current at the top and bottom of the elevator's travel. See ELECTRICAL MANUFACTURING INDUSTRY.

**ELECTRIC NAVIGATION.** Vessels of small draft are now propelled by electricity. The power drives a motor, which actuates a screw propeller. The current is generally sup-

plied by a storage battery. From their noiselessness electric boats are peculiarly available for nocturnal torpedo operations, and the universal equipment of modern warships with electric lighting and power plants makes their use possible at all points. This type is often termed an electric launch, and most of all electric boats fall under this category.

**ELECTRIC PEN,** a pen invented by Thomas A. Edison, bearing on its head a small magnet, arranged to rapidly reciprocate a needle so that it protrudes and withdraws from the point. When connected with a battery this pen may be used to write or make drawings which appear on the paper as a series of perforations. The paper so perforated can be used for stencil printing, and several hundred copies struck off.

**ELECTRIC PENDULUM,** a form of electroscope consisting of a pith ball suspended by a non-conducting thread.

**ELECTRIC PHONOGRAPH.** See PHONOGRAPH.

**ELECTRIC POLICE SIGNALS.** See ELECTRIC SIGNALING.

**ELECTRIC POWER.** See ELECTRIC MACHINE; POWER.

**ELECTRIC RAILROAD.** See TRACTION, ELECTRIC.

**ELECTRIC RAILROAD BLOCK SIGNALS.** See ELECTRIC SIGNALING; BLOCK SIGNAL SYSTEM.

**ELECTRIC REPULSION,** the mutual tendency of similarly electrified bodies, or similar electric charges, to repel one another.

**ELECTRIC RESISTANCE,** that non-conducting property of a substance that resists or limits the passage of an electric current; the characteristic that goes to make a good non-conductor or insulator; sometimes called reluctance. It is defined mathematically as equal to the electro-motive force divided by the current-strength. All metals present some resistance to an electric current, mercury being the most resistant. For the relative resistance of metals see table under ELECTRIC CONDUCTIVITY. The resistance of a conductor varies directly as its length and inversely as its cross section. A box containing coils that are designed to resist or impede a current is called a resistance-box or rheostat. The starting-box of an electric car and the controller of a machine run by motor are based on this principle. The unit of electrical resistance is the ohm. See ELECTRICAL UNITS.

**ELECTRIC SIGNALING.** While it is true in a broad sense that any method of communicating intelligence to a distance is embraced in the term telegraphy, in the present instance the term electric signaling will be employed to cover the signaling systems and methods described in this article. This term is perhaps the more appropriate inasmuch as certain of the systems to be outlined in reality partake more of the nature of mere signals than of a means of transmitting intelligence as that term is generally understood. Almost without exception electro-magnetism is employed in the operation of electric signals. See ELECTRO-MAGNETISM.

**The Electric Door-Bell.**—This is perhaps

the best known and one of the simplest methods of electric signaling. In its operation it employs a primary battery, a push button at the door, a vibrating bell within the house, and a wire connecting the push button and the bell. The bell and its armature, the connecting wire, the push button and the battery, comprise the electric circuit. The push button is merely a key consisting of two strips of metal which when pressed together allowed the current to flow. The electric bell consists of a coil of wire wound around a soft iron core. Its armature carries at its free end a small hammer which, when the armature is attracted, strikes against a small gong, ringing it. The vibration of the hammer is brought about by a very simple device. Normally the armature rests against a contact point which is a part of the circuit; the armature itself also being a part of the circuit. The circuit is normally open at the push button. When this button is pressed the circuit is closed and the armature of the bell is forthwith attracted, its hammer striking the gong at that instant. In the act of moving forward, however, the armature leaves the contact point against which it had been resting, with the result that the circuit is opened at that point. This has the effect of permitting the magnet of the bell to lose its magnetism, whereupon the armature falls upon its contact point, again closing the circuit with the result that the armature is again attracted, which action is continuously repeated so long as the push button is pressed in. A small spiral or tension spring suffices to keep the push button normally open. See ELECTRIC BELL.

**Annunciator Signals.**—The "annunciator" or call-bell systems so generally used in hotels and offices utilize the principle of the door bell. Annunciator systems in fact might be termed multiple electric door-bell systems. Usually a wire runs from each room to a central point or office where the annunciator is placed. This annunciator contains within its case a small electro-magnet for each room. One battery is caused to supply the current for all the circuits by simply connecting the wire from each room to the terminals of the battery. In a similar way one bell at the annunciator is caused to respond to all the calls that come. The armature of each electro-magnet within the case carries a small shutter, on which is placed the number or letter of the room with which it is connected. This shutter is held out of sight by means of a small catch hook attached to the armature of the magnet until the push button in a given room is pressed, whereupon the armature is attracted, releasing the shutter, which instantly drops, showing the number. At the same time the annunciator bell rings, directing the attention of the clerk to the call. In other forms of annunciators the falling of the armature is caused to deflect a small arrow on the face of the case, beneath where is marked the number, name or letter of the room. There may be almost any number of rooms for 1 up to 100 or more connected with one annunciator. In practice a single wire, called the "common return" wire, is usually run from the battery and annunciator to all rooms. From each room a separate, individual wire is then run, from the "common return" in the room, through the push button and then down to the electro-magnet in the annunciator, there-

by supplying a separate circuit for each room. In order to restore the shutters to their normal position after the call has been received, a rod is provided with a knob at its lower end which projects below the under side of the case containing the annunciator magnets. By pushing up the rod a cross-bar within the case is raised and this cross-bar in turn lifts up and resets the shutter and armature for the next call. In the later form of annunciators which are now frequently operated by alternating current of low voltage, the shutters of the annunciator are electro-magnetically reset by merely pushing a button, thereby closing the circuit of an electro-magnet.

**Burglar Alarm Signals.**—For simple domestic purposes the arrangement employed for burglar alarm signals is also closely akin to the systems just described, the main difference being that the finger push button is displaced by a circuit closing contact in the frame of a window or the jamb of a door. To bring about the result desired the circuit closer is placed on the frame of the window in such a way that the movable portion of the circuit closer projects beyond the surface of the window frame. The contacts of the circuit closer are held apart normally by a simple spring. In order that when the window is closed this projection may not be depressed, a piece is cut out of the window sash at a point directly opposite the projecting circuit closer. In an analogous manner the circuit closer is attached to a door jamb. The wires leading to the circuit closer are concealed behind the woodwork. When a window is raised or a door is opened by an intruder the contact points of the circuit closer are brought together, whereupon the annunciator bell is rung, giving the alarm, and at the same time the room where the door or window has been opened is indicated by the dropping of the corresponding shutter in the annunciator. The annunciator is located in any desired part of the house, usually in a bedroom. The method described is termed an open circuit method. In such systems what is known as open circuit batteries, such as the ordinary dry batteries, may be used. In some cases, to guard against a momentary opening of a door or window, such as would only occasion a short ring of the alarm bell, not sufficient perhaps to arouse a sleeper, an auxiliary arrangement is provided at the annunciator consisting of a drop arranged to close the bell circuit continuously until the drop is reset. A small switch is provided near the annunciator by means of which the alarm circuit may be opened during the daytime so that needless alarm may not be given by the ordinary opening of windows. Other switches are also used for the purpose of testing the various circuits to see that they are in proper working condition. See ELECTRIC ANNUNCIATOR.

**Central Office Burglar Alarm System.**—This system, as the name implies, relates to one in which the ringing of an electro-magnetic alarm in a central office will announce the presence of intruders in the building or buildings in which the protecting apparatus is installed. The central office may be any convenient distance from the protected buildings. These systems are frequently termed electric protective systems. The plan usually adopted is to run a net-work of wires through parti-



tions, across floors, skylights, etc. These wires are part of a circuit extending to the central office, and the said wires are so connected with the circuit that any interference with them, after they have been "set," will cut out a high resistance, consisting of a coil of wire, suitably placed in the circuit of the protected building. The cutting out or short-circuiting of this resistance will so increase the strength of the current in the circuit as to operate a "double-balanced" instrument in the central office. If on the other hand the resistance is not "cut out," but instead the wires of the circuit be cut or broken, by accident or design on the part of intruders, the consequent absence of current, or even a slight decrease of current, will likewise cause an alarm in the central station. The doubled-balanced instrument at the central office is usually a relay, the armature of which carries a needle that normally stands at a zero point, from which point it may be deflected in either direction. An increase of current on the circuit deflects it in one direction—a decrease of current allows a spring or weight to deflect it in the other direction. In either case, the alarm is given when the needle moves and an attendant is despatched to the premises from which the alarm has emanated. Each relay is of course suitably numbered or otherwise designated in the central office so that the building with which it is connected is known.

**Telegraph Message Service or Emergency Signals.**—This service relates to the supplying or calling of messengers, policemen, firemen, etc., at the call of or by a "subscriber," in whose house or office a "call box" has been placed. This call box is electrically connected by means of a wire with a central office at which the messengers are located, and from which office communication with police and fire headquarters can quickly be made. Each call box is numbered and is supplied with what are termed "make and break" attachments which are set in operation by the turning of a crank on the cover of the box. These attachments, when thus operated, transmit automatically to the central office the number of the box, which at once indicates to that office the location of the signaling box. The construction and operation of the call box are as follows: A crank is mounted rigidly with a recoil spring on a shaft. On this shaft is also mounted, but loosely, a cog-wheel. A "break-wheel," having a number of slots in its periphery, is geared with the cog-wheel in such a manner that it receives a tendency to turn in a given direction, but it is normally prevented from turning by the engagement of a pin on its side with a curved cam which is attached to a prolongation of the crank arm. When, however, the crank lever is turned to, say the right, preparatory to sending in a call, the cam is automatically moved out of the path of the said pin and the break-wheel is then free to move. By a suitable pawl and ratchet, the cog-wheel is prevented from moving when the crank is turned to the right. The effect of turning the crank is to wind the recoil spring. When the crank is let go the spring unwinds and turns with it the break-wheel which completes a revolution; at the end of which it is again held by the pin as before. The break-wheel is made part of the circuit leading from the box to the central office. A flat metal

spring which is also part of the said circuit rests on the periphery of the break-wheel in such a manner that when the wheel is making its revolution the spring falls into the slots on the said periphery and opens the circuit as many times as there are slots provided. If, for instance, the number of a given box is 24, there will be cut on the periphery two slots in close succession, then an interval of unbroken metal surface followed by four slots in succession. The circuit in such a case, as the wheel rotates, will be opened twice in succession, closed for an interval, and then opened four times in succession, with the result that a bell at the central office will give out, first two strokes, and then four strokes, on its gong. A large number of such boxes can be placed on one circuit without causing confusion. The call box just described suffices to send in a swift call for a messenger. When it is desired to make it possible to call a policeman, doctor or fireman by the same type of box, it is provided with a "stop" that projects through the cover in such a way that the crank cannot be moved beyond a certain point. The ordinary position of the "stop" would be at the messenger call, in which case the number of the box only would be sent in when the crank is turned. If, however, a doctor should be desired, the stop is moved to a point marked "doctor," on the cover of the box, and in turning the crank it is moved up to that point. This farther movement of the crank has the effect of bringing into operation one or more additional slots on the periphery of the break-wheel in consequence of which the box number is preceded by one or more single strokes on the bell, which indicate to the central office attendant that a doctor, fireman or policeman, as the case may be, is desired.

**Fire Alarm Telegraph Signals.**—The importance of electricity as a time saver in announcing the existence of a fire can scarcely be overestimated. A special feature of the electric fire-alarm system is that it not only gives the alarm, but also indicates to the firemen the location of the fire, or within a very short distance thereof. It may be noted that a simple fire-alarm system is in many respects similar to the systems just described, in that it consists of a central office or station in which alarm apparatus and battery are located, and of signal boxes in the street and elsewhere by which to transmit alarms to the central office. A wire connects the central station with the various signal boxes in the streets and fire-engine stations. In each signal box is placed a break-wheel, practically similar to that used in the call-boxes of the district messenger or emergency service; the main difference being that owing to the more exposed position of the fire-alarm boxes and their greater relative importance, more substantial boxes are employed. In general these signal boxes are supplied with an inner and outer door to protect the apparatus from the elements. The signal boxes are provided with a crank or a hook which on being operated causes an alarm to be sent to the central station giving the number of the box from which the call has emanated. The signal box is also provided with a small electric gong, which rings each time the circuit is opened. This intimates to the one sending in the alarm that the alarm is being properly transmitted. It also

serves the purpose of intimating to anyone who might open an adjacent box to send in an alarm therefrom, that the alarm is already being sent, thus preventing interference. At the central station and the various fire stations a gong is struck a number of times corresponding with the number of the box from which the alarm emanates. In the same circuit also an ink-recording register in the central office marks on a paper strip the number of the signaling box, thus giving a permanent record of such alarm. Inasmuch as it is not good practice to put more than 25 or 30 signal boxes on one circuit, but yet is very important that all the fire stations in a given district should receive the alarm, a repeating device is utilized at the central station which receives the alarm from any one of the circuits and thereupon repeats it automatically or manually to all the other circuits. It frequently happens that two or more street boxes on the same circuit are pulled simultaneously by different people. To prevent the confusion of signals that this would ordinarily entail special arrangements have been devised, termed the non-interfering succession signal fire-alarm boxes. These boxes not only prevent interference with the signals already in process of transmission by any given box, but also permit every box that may have been pulled simultaneously to send in its signal in rotation, automatically.

**Automatic Fire-Alarm Signals.**—In many of the large cities of the United States an auxiliary to the regular fire-alarm system, consisting of some form of thermostat included in a circuit in the building to be protected, is employed. This system again is somewhat analogous to the messenger telegraph system described, the chief difference being that in the one case the signal box is manually operated, while in the other case an increase of temperature, due to fire, by affecting the thermostat causes the alarm to be transmitted. Thermostats are of different types. One type consists of a crescent-shaped spring, made up of two strips of metal, steel and copper, one over the other. One end of the spring or strips is fastened to a support, the other end is adjacent to a contact point of an electric circuit. As the metals named do not expand equally under increased temperature the spring as a whole bends or buckles when the temperature increases, and the movable end makes connection with the contact, thereby closing the alarm circuit with the result desired. Other types of thermostats are made of easily fusible alloys. Still another form of thermostat consists of a drum-shaped box, holding substances which have a high expansion under increased temperature. The expansion causes the ends of the box to bulge, thereby closing an alarm circuit.

**Police Electric Signals.**—These may be considered as more or less amplified fire-alarm systems, consisting as they do of signal boxes placed on poles and in booths along the routes of the policemen; from which boxes signals of all kinds may be transmitted to and from police headquarters. The signal boxes are connected by a suitable wire with headquarters; and each box has a break-wheel, carrying the number of the box. A telephone outfit is also placed in the box by means of which the policemen may converse with the main station. In fact the tele-

phone is used nearly exclusively, the policeman as he arrives at a signal box sending in a signal which intimates to the attendant at headquarters the number of the box at which he has arrived in the course of his beat, whereupon the attendant communicates with the policeman and takes his number, thus getting a record of his whereabouts. If the officer desires to send in a special signal of any kind, as for an ambulance or wagon, or for assistance, he can do so by a special arrangement within the box. In some cities certain citizens are supplied with keys of the signal boxes. Such citizens are authorized to send in signals for police assistance in cases of emergency, and thus the police force is practically augmented by a volunteer service. In many cities also the police signal apparatus is kept in a kiosk or sentry-box on the sidewalk curb. On the top of these boxes an electric colored lamp is placed and so connected that it may be lighted from police headquarters to call a policeman to the post for instructions.

**Railway Electric Block Signals.**—A block system in brief consists of a means of showing manually or automatically certain signals which indicate to the engineer of a train that a certain portion or section of the track before him is "clear" or occupied. The road is divided into sections or blocks which are of various lengths depending in a great measure on the topography of the route and the amount of traffic. The length of a block varies from 600 feet to several miles. The signals employed in a "block" are either "safety," "caution" or "danger," represented by a white light or sign, a green light or sign and a red light or sign, respectively. The sign usually consists of the well-known semaphore arm or blade. In automatic electric systems the circuits and apparatus are generally so arranged that the entrance of a train into a "block" sets the danger signal and that signal is displayed until the train passes out of that block into the next, when the danger signal is lowered and the caution signal is shown. When the train passes into a second block ahead the caution signal is lowered and safety is shown. The part assigned to electricity in the operation of these signals consists in actuating electro-magnets which are placed in circuits capable of being opened, closed or short-circuited by the car wheels of a train, which electro-magnets are caused directly or indirectly to operate the signals. In what is known as the Hall Block Signal system the blades are operated against gravity by an electric motor placed in a case at the top or foot of the pole supporting the signals; suitable battery being provided for the operation of the motor. Thus when a train enters a given block a circuit is closed which starts the motor which in turning, by a system of cog-wheel gearing, raises the blade to a pre-arranged point, at which time the motor circuit is automatically opened and the signal is held in position by an electro-magnet until the train moves out of the block, when the blade is released and falls by gravity, means being provided to graduate and safeguard the fall of the blade by means of friction, due to the action of a centrifugal governor. Another electric block system uses a disc enclosed in a drum-shaped box on the top of a pole. This disc is operated by an electro-magnet, the latter being attracted by an electric current which is under

control of the engine, the latter operating, as it passes, a heavy circuit closer by the side of the track. There is one of these circuit closers at the beginning and end of a block. The engine thus sets the signal to danger as it comes into a block and sets it at clear as it leaves the block. A device named the Miller Cab signal is different from the foregoing systems. It consists of suitable apparatus and battery for operating certain electric lights in the engine cab. Normally a white light is burning, but when there is another train on the block in which the train enters, the circuits are so operated that the white light is cut out of the circuit and a red light is lit up in its place. This notifies the engineer of the near proximity of another train. See BLOCK SIGNAL SYSTEM.

For a more detailed and illustrated account of the foregoing systems, the reader may be referred to the author's 'American Telegraphy and Encyclopædia of the Telegraph.'

WILLIAM MAVER, JR.,

Author of 'American Telegraphy.'

**ELECTRIC SMELTING.** See ELECTRIC FURNACES; METALLURGY.

**ELECTRIC STORAGE BATTERY, The.** Electrical energy is developed in commercial quantity at the present day almost exclusively by means of a dynamo-electric machine, driven in turn by a steam engine, gas engine, water wheel or other prime mover. A plant of either of these kinds is somewhat complicated, so as to require skilled care in its operation; the electrical energy is available only while the machinery is in actual motion, and at such points as are connected with the generating plant by suitable electrical distributing circuits.

A device to supply electrical energy, under isolated conditions, and in such form as to be instantly available over long periods of time is therefore an almost imperative necessity and the device which science has developed for this purpose is known as the electric storage battery.

The storage battery does not, as its name might imply, store energy in the electrical form, but rather in the chemical, and hence it belongs to the general family of electro-chemical apparatus.

**Electro-Chemistry of Storage Battery.**—The essential "working parts" of a battery, broadly speaking, are three in number, namely, active material of the positive and negative plates, respectively, and the electrolytic solution, surrounding and electrically connecting the first two.

For the purpose of causing these working parts to function as a battery, there are required a number of subsidiaries, equally necessary, whose duties are mainly mechanical and electrical in their nature. The active material consists of a more or less cemented mass of powder, possessed in itself of very little mechanical strength. To retain this material in working condition there are required the "grids," which, as the name implies, are in most cases flat metallic plates of very open grid-like structure, with projections or "lugs" at one corner, to serve for making the electrical connections.

Note.—The scale of sizes of the various figures refers in all cases to linear dimensions.

Since the plates of opposite polarity would quickly discharge themselves if allowed to touch, they must be kept apart, and this is invariably accomplished by the insertion of "separators" between them.

As the electrolyte is almost invariably a liquid, rarely a jelly-like substance, there is required a retaining vessel, glass or hard rubber jar, lead lined tank or steel jar, according as the case may be.

Reference to Figs. 24 and 25 will make clear the general construction; the plates, alternately positive and negative side by side, with separators between, and resting or hanging in a jar which holds the electrolyte. A very necessary detail of design is that there shall be left sufficient clear space beneath the plates so that the sediment which gradually collects may settle there without contacting with the plates and causing a short circuit.

While attempts have been made to utilize all sorts of materials as "working parts," the successful combinations have narrowed down, until to-day there are practically only two in commercial operation.

The older and far the most generally used is known as the *lead-sulphuric acid* type; the newer as the *alkaline*, or, more generally, the *Edison* type. A description of each type separately will be followed by a brief analysis of its characteristics.

**Equations of the Alkaline Battery.**—The Edison battery is chosen as the representative of the alkaline type because, although other varieties have been developed, and have met with limited success in Europe, yet Mr. Edison has carried the development of the type so much beyond any of the others that to-day his is the only alkaline battery of commercial importance.

The positive active material consists of nickel peroxide; the negative of spongy, metallic iron; the electrolyte of caustic potash or caustic soda solution. The chemical affinity of the sponge iron for oxygen constitutes the chief working force of the cell, diagrammatically represented in Fig. 1, in which A and B are the positive and negative plates and C the active material, immersed in the electrolyte within the retaining vessel.

The reaction of discharge may be explained thus: KOH readily splits up into the two "ions" OH and K; the former tending to travel to the negative plate, and there combine to form Fe<sub>3</sub>O<sub>4</sub> and H<sub>2</sub>O; while the K ion tends to travel to the positive plate, and there combine with part of the oxygen of the NiO, and with water from the electrolyte, thus forming again KOH, exactly equal to the initial quantity.

The reaction may be represented as follows:

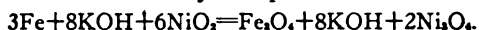

It will be seen that the net result is a transfer of oxygen from the positive to the negative, accompanied by a concentration of caustic potash at the positive and a dilution at the negative; the total amount of caustic in solution remaining constant throughout. The reaction of discharge is held in check, and the electricity is furnished to the electrodes much as in the lead cell, described more fully on a subsequent page. During the process of charge the reactions are exactly reversed, with metallic

iron as the result at the negative plate and nickel peroxide at the positive.

The reaction on charging, however, does not take place directly in proportion to the amount of current, with the result that the charge must always considerably exceed the discharge in order to restore the cell to its initial condition. Moreover, the active materials in discharge are never completely converted according to the reactions shown; there always remain large proportions of metallic iron and nickel peroxide, even in a discharged cell.

**Description of Edison Cell.**—Caustic potash solution has but slight effect upon steel and none upon metallic nickel; hence nickel plated sheet steel constitutes an ideal material for almost all the structural parts of an alkaline cell, and is used for positive and negative plates, as well as for retainer.

The positive plate, Fig. 2, consists of a number of thin-walled steel tubes placed side by side and united by a surrounding frame,

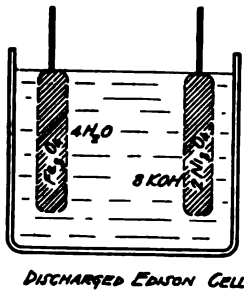
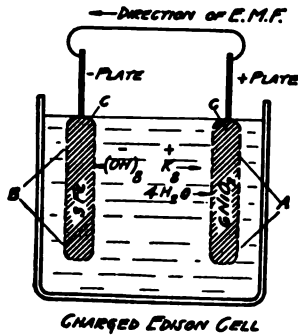

FIG. 1.  
Diagram of Edison Cell.

likewise of sheet steel, nickel plated. Each tube is made up of a spirally wound, and double scamed, strip of thin sheet steel very finely perforated and filled with the active material, nickel peroxide. This material, however, happens to be an extremely poor electrical conductor, and in order to give it the necessary conductivity the material within the tube is interspersed with extremely thin transverse discs of metallic nickel, about 80 of them per inch length of tube. The nickel is prepared in the shape of extremely thin flakes, and a measured quantity of these is fed into the tube, alternately with a measured quantity of nickel hydroxide (which is later converted into nickel peroxide). After each double charge of flake and hydroxide a ramrod enters the tube and

compresses the contents which are thus gradually built up till the tube becomes full, when it is pinched off and later assembled with others

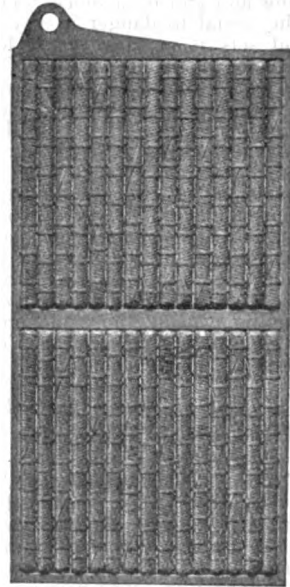

FIG. 2.  
Edison Positive Plate — Vehicle and General Service — 1/3 size.

into a complete plate. The usual diameter of the tubes is about one-fourth inch, though latterly a smaller size is also used to some extent. In assembling the plates right and left wound tubes are used alternately to eliminate twisting



FIG. 3.  
Edison Negative Plate — Vehicle and General Service — 1/3 size.

tendencies, and each tube is strengthened by a number of tight-fitting steel rings at frequent intervals.

The detail with which the manufacture of this plate has been worked out is extremely interesting, but limitations of space preclude a full description.

The negative plate (Fig. 3) is somewhat similar in design, with the difference that the active material, in this case metallic sponge iron, initially introduced as oxide of iron, is contained within small rectangular pockets or boxes of perforated sheet steel. The surface of the boxes is corrugated to give strength, but as the iron inside is a good conductor there is not required the mechanical pressure which necessitates the cylindrical form of the positive tubes. The pockets are about one-eighth inch in thickness and are locked by pressure into a surrounding frame of sheet steel very similar to that of the positive.

Positive and negative plates are assembled alternately, with small hard rubber insulating strips between; and the plates of each kind are united by a bolt extending across the whole group, through the holes at the top corner, as shown in Fig. 4. Hard rubber frames around

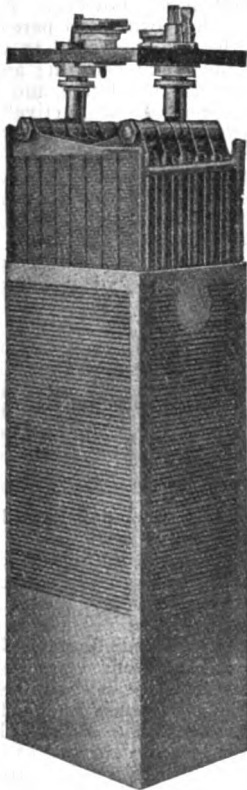
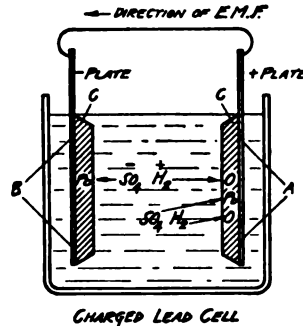

FIG. 4.  
Edison Cell — for Vehicle and General Service. Plates lifted to show method of assembling. About 1/5 size.

the edges and bottom of the group insulate it effectively from the steel case which holds the electrolyte and retains the whole cell as a working unit.

The steel case is closed by a cover of the same material, which is welded all around so as to be perfectly air tight. This feature is

necessary in order to exclude the carbonic acid of the atmosphere, which is readily absorbed by caustic solution, and which if allowed thus to enter into an alkaline cell exercises a very detrimental effect upon its operation. A check valve in the cover permits the egress of oxygen and hydrogen liberated during charge, while it



CHARGED LEAD CELL

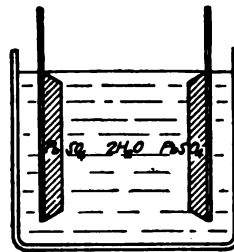

DISCHARGED LEAD CELL

FIG. 5.  
Diagram of Lead Cell.

excludes all atmospheric air with its contamination of carbonic acid.

The Edison cell of to-day is a very highly developed piece of electro-chemical apparatus, bearing ample witness to the genius of its inventor. The fact of its being built of nickel plated steel throughout gives it a ruggedness and a finished appearance which can hardly be matched by other types. If operated under favorable conditions it will last for a long time, often upwards of 1,000 cycles of charge and discharge.

It possesses on the other hand certain apparently inherent properties which very much limit its application, and which absolutely exclude it from many of the fields to which storage batteries are applied; under the heading of characteristics these points will be more fully brought out.

**Electro-Chemical Equations of the Lead-Sulphuric Acid Battery.**— The oldest and most generally used type of storage battery employs as its active materials peroxide of lead for the positive plate, spongy metallic lead for the negative, and for the electrolyte an aqueous solution of sulphuric acid, of about 25 to 40 per cent strength.

A cell of this kind is diagrammatically shown in Fig. 5, in which A and B are the positive and negative plates, respectively, each with a coating or cake, C, of active material, held in contact with it, while both plates are immersed

in the sulphuric acid electrolyte, held in a suitable containing jar.

Between sulphuric acid and metallic sponge lead there exists a strong chemical affinity, which constitutes the basic operating force of the lead cell.

So soon as the internal reactions are permitted to take place, by the closing of the external circuit, the sulphuric acid,  $H_2SO_4$ , begins to split up,  $SO_4$  going to the negative plate, there combining with the sponge lead to form lead sulphate,  $PbSO_4$ , and in so doing liberating at the negative plate a quantity of minute negative charges carried by the individual  $SO_4$  "ions" (as these disengaged groups are termed); and at the same time the hydrogen,  $H_2$ , proceeds to the positive plate, there combining with one part of the oxygen of the lead peroxide to form water, and giving up an equivalent quantity of minute positive charges, carried on the individual H "ions." Simultaneously the  $PbO$ , which results from this action, unites with another part of  $H_2SO_4$  to form lead sulphate and a second molecule of water.

The reaction may be represented as follows:  
 $Pb + 2H_2SO_4 + PbO_2 = PbSO_4 + 2H_2O + PbSO_4$ .

The discharge thus results in the formation of lead sulphate at both plates, the disappearance of sulphuric acid, and the formation of water at the positive. It may be said, in brief, that these reactions are held in check by the fact of the charge upon the negative plate acting to repel the negatively charged  $SO_4$  ions; while the charge upon the positive plate in like manner repels the positively charged H ions. Immediately the respective charges upon the two plates are lessened by closing the external circuit (i.e., the potential difference between them is reduced), the equilibrium between electrical and chemical forces ceases and the ions rush to the respective plates and discharge their minute unit charges, thereby maintaining the potential difference of the cell nearly constant.

But if there be applied to the cell terminals a potential difference slightly greater than that of equilibrium, the chemical forces are overbalanced by the electrical, with the result that these various internal movements are reversed, so that the original condition of the "working parts" is restored, as indicated in Fig. 5.

During charge there are thus restored to the electrolyte the two parts of  $H_2SO_4$ , absorbed by the plates in discharge, and simultaneously there are removed the two parts of water given off in discharge; at all times there remains a surplus of  $H_2SO_4$  in solution.

It is to be noted that in charge these reactions are quite complete, so that the active materials are entirely converted into metallic lead and peroxide of lead, respectively; but that on discharge they are never in practice carried to the theoretical limit, and a large proportion, usually above 60 per cent, of the metallic lead and lead peroxide remains even after a cell is completely discharged. The fully charged condition, however, is not accomplished with 100 per cent efficiency; the charge (in ampere hours) must exceed the discharge by 10-15 per cent, the loss manifesting itself by the evolution of hydrogen and oxygen.

**Brief Historical Sketch of the Lead Battery.**—The lead storage battery of to-day exists in several distinct types, and as each is the

survivor of many unsuccessful attempts, and as development has been gradual, it is convenient to treat it historically.

About the year 1860 Plante, experimenting with a number of electrolytic cells, placed a couple of lead plates in a vessel containing weak sulphuric acid, through which, in series with a galvanometer, he passed an electric current. After the current had flowed for some time in one direction, he stopped it, and, bringing the two cell terminals together, was surprised to find from a reverse swing of the galvanometer, still in circuit, that the cell gave back some of the electrical energy that had been applied to it. Repetition of the experiment showed that the cell slowly but steadily gained in capacity for storing energy, while occasional reversals greatly accelerated the gain.

The explanation of the phenomenon as we now understand it is this: Metallic lead, when placed in sulphuric acid, is immediately attacked, with the formation of a thin skin of lead sulphate, which, being insoluble, protects the metallic lead inside and prevents further action. Electrolysis, however, converts the sulphate upon the positive to peroxide of lead and permits the sulphuric acid to work a little further into the metal beneath; and it is thus that the action is cumulative and the amount of lead in a porous or "active" state continually increases. Electrolysis affects the negative, however, merely in reducing the lead sulphate to metallic lead, so there is here but little cumulative action, and hence occasional reversal is necessary to build up the thin skin of "active material" on both plates together.

Months of charge, discharge and reversal were required to build up a layer sufficiently thick to make a battery of useful capacity. Hence other inventors set about to shorten this arduous process, known as "formation," and finally Faure, in France, and Brush, in America, about simultaneously discovered that they could apply to the plates a thick coating of lead oxide, made into a sort of putty-like paste with sulphuric acid, which, by means of a single slow charge, was converted into thoroughly porous active material.

Subsequent improvements on Plante's process have shortened it until now it is about as quick and as cheap as Faure's process, so that at the present time both are successfully employed, the Faure very much the more extensively.

**Plante and Pasted Types Compared.**—The Plante and "pasted" types as now used differ very distinctively in their design, though electrically the difference is much less than would be expected. The Plante plate consists of pure lead, upon the surface of which there is "formed" a thin layer of "active material" having a thickness of the order of a few hundredths of an inch. The layer is necessarily thin in order to prevent its peeling off readily; hence a very large surface is required, and this is usually obtained by making the lead plates in the form of a number of parallel transverse leaves, as shown in Figs. 13 and 14.

The surface is increased by this construction anywhere up to 8 or 10 times that of a plain sheet of equal superficial area.

The "pasted" (Faure) type, on the other hand, is characterized by a relatively thick mass of porous active material, retained by an open-

work grid or lattice of lead-antimony alloy, as shown in Figs. 6, 7 and 8.

Both types of plate can be used as either positive or negative, but certain characteristics make the one or the other better suited to particular classes of service, as will appear hereafter.

**Negative Plates.—Exide Negative.**—The negative plate of a lead storage battery, at least theoretically, is quite a simple matter; the sponge lead which constitutes the active material has considerable mechanical tenacity and is therefore relatively easy to hold in place upon the skeleton frames or "grids" to which it is applied. There is no destructive action upon the lead-antimony alloy of which these grids are made, and they may therefore be as light as methods of manufacture will permit. Fig. 6 shows a negative grid of the type which is now standard in the United States, and which is still best known under its original name of the "Exide." Fig. 7 shows a cross-section of the same grid, and shows how the active material occupying the interior spaces is locked



FIG. 6.  
Exide Negative Grid.  
About 1/5 size.

in place so as to be both retained and protected, while Fig. 8 shows the finished plate, the active material filling all the interior spaces. This type of plate is used in sizes from about three square inches surface up to 700, in thickness

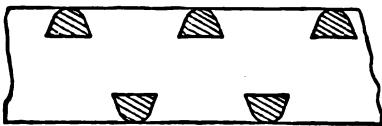

FIG. 7.  
Cross Section — Exide Grid.

from three-thirty-seconds to one-fourth inch, and for every variety of purpose for which lead batteries are employed.

**Box Negative.**—For some purposes, however, it is desirable to have a plate which will give the maximum possible life, consequent increased weight being a secondary consideration. To meet this requirement the "box" negative

shown in Fig. 9 is used. This plate may be considered as a development of the exide type, inasmuch as the active material is held within

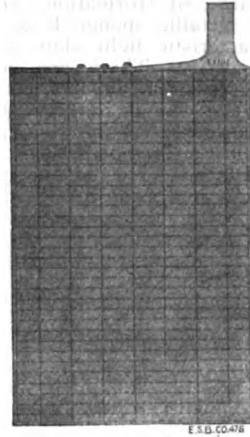

FIG. 8.  
Exide Negative Plate—  
Vehicle and General Service.  
Approx. 1/5 size.

two protecting surfaces, which, in the case of the box plate, consist of finely perforated lead sheets, while in the exide type they consist of parallel bars with relatively large openings between.

The box plates are used almost entirely where long life is the main consideration, but the greater weight of grid, with consequent greater cost, has caused them for most purposes to be superseded by the Exide type.

The grids of the Exide type are castings of antimony-lead alloy, made as light as possible consistent with necessary mechanical and electrical conductivity. The box grids are composite, consisting of perforated lead sheets, upon which are cast intersecting ribs, or bars, of antimony-lead alloy, which gave the necessary strength; and each plate consists of two parts riveted together, with the active material enclosed between them.

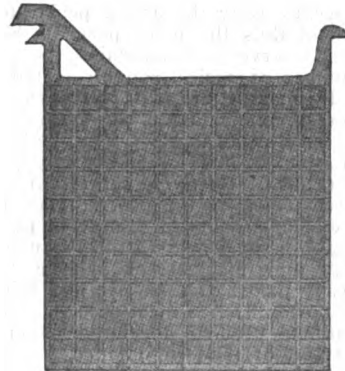

FIG. 9.  
Box Negative Plate—General  
Stationary Service—1-10 size.

While any oxide of lead may be used for the active material of negative plates, a long process of elimination has finally resulted in

the universal adoption of litharge  $PbO$ , for this purpose, applied as a putty-like mass, made by mixing the litharge with dilute sulphuric acid. An initial charge, or "formation," converts the litharge into metallic sponge lead, giving the plate a characteristic light slate color.

*Plante Negative.*—There are still a few Plante negatives used, in this country only, such a one being shown in Fig. 10, but their weight and cost are against them, and they are to-day almost a thing of the past.

*Positive Plates.*—The positive plate offers a more complicated problem, chiefly because lead peroxide, under the conditions which exist in a storage battery, does not possess much sustained mechanical strength, but gradually becomes soft, and in time is loosened from the plate, falls to the bottom of the cell and thenceforward plays no useful part in the life of the battery.

To maintain the capacity over an extended period of charges and discharges three distinct methods are employed.



FIG. 10.  
Plante Negative Plate for Train  
Lighting— $1/6$  size.

*Pasted Positive.*—In the pasted type of plate, when new, only a part of the lead peroxide is available for entering into the chemical reactions of the cell, as the acid penetrates only partially into the interior of the mass. As the surface wears away the action penetrates farther in, and thus the inner part of the mass acts as a reserve and maintains the capacity for a number of cycles, roughly stated at 300 to 500. By making the plate very thin, say of the order of one-eighth inch, the reserve of active material is cut down to a minimum, hence giving a plate of maximum capacity per unit of weight, but of relatively shorter life.

Positive plates of the pasted type are universally employed where lightness, or maximum capacity for given weight, is the primary consideration, and the correct balance between thick, heavy plates of long life and thin, light ones of shorter life, to meet special conditions, is a continual problem to the designer. The general trend of modern practice, however, is toward much thinner plates than were thought practicable a few years ago, a thickness of three-thirty-seconds inch being quite common.

The Exide type of pasted plate, Fig. 11, which has become standard in the United States, and largely so in Europe, is very similar to the negative plate, except as to its active material. The grid, Fig. 12, is, however, more substantial

in its design than the negative, in order to withstand the greater corrosion and mechanical stresses to which it is subject. While various oxides, or mixtures of such, are used by differ-



FIG. 11.  
Exide Positive Plate—Vehicle  
and General Service.  
Approx.  $1/5$  size.

ent manufacturers as positive active material, the usual material is red lead,  $Pb_2O_3$ , mixed to a putty-like mass with weak sulphuric acid, or ammonium sulphate solution. The initial charge, or formation, converts this into lead peroxide, a material which when dry has about the consistency of plaster of Paris and a very characteristic dark chocolate brown color.

*Plante Positive.*—The Plante plate is also subject to the continual, slow washing away of its lead peroxide, but the original layer is more durable than the peroxide made from red lead, so it lasts a considerable time in spite of its



FIG. 12.  
Exide Positive Grid.  
About  $1/5$  size.

thinness. Moreover, all the while that the original layer is disintegrating and falling away, the electrolytic action is penetrating farther into the metallic lead of the plate and forming



fresh active material, in the manner of the Plante formation, and thus there is a balance between loss and gain, and the capacity of the plate is maintained for a long period, say about

performs the electro-chemical function of the plate.

The combined mechanical and electrical endurance of this type of plate has given it a very broad field of application; its weight, roughly triple the pasted type, and its consequent cost constitute its chief limitations.

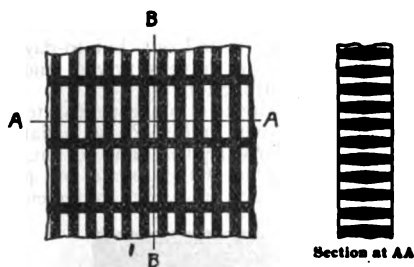

FIG. 13.  
Cross-Section Tudor Positive Plate. Not to scale.

two or three times as long as in the case of the pasted plates. For effecting this extended life, however, there is required a large reserve of pure lead; so that in actual practice the Plante plates weigh from two to three times as much as pasted plates of equal capacity.

Figs. 13 and 14 show a Plante type of plate known in this country as the "Tudor," used largely in Europe, and consisting of an integral one-piece casting; while Fig. 10, though actually a negative, may be used as illustrating the Gould type, made from rolled sheet lead, by a spinning process.

In this country and in England a modified Plante plate, known as the "Manchester," has largely superseded all of the above, chiefly on account of its superior mechanical construction. The Plante plate is made of pure lead, because this metal is attacked by the electrolytic action at about the right rate to replace the loss of lead peroxide; but pure lead is very soft, hence these plates are much subject to buckling and breaking. The Manchester plate (Fig. 15) differs in that a rigid grid, or frame, of anti-

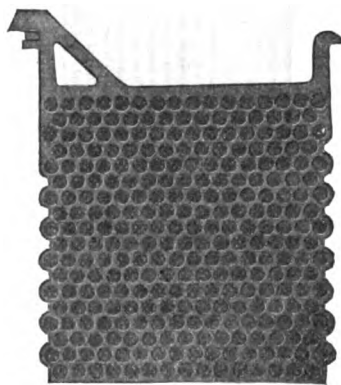

FIG. 15.  
Manchester Positive Plate—  
General Stationary Service.  
1/10 size.

*Ironclad Type.*— During the past five years a third type of positive plate has come into prominence in this country, founded on the principle first successfully developed by Philpart, in France, about the year 1898. This

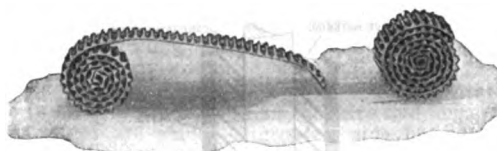

FIG. 16.  
Manchester Button. About 1/2 size.

plate, known as the "Ironclad," is shown in Fig. 18, and differs from those heretofore discussed in that a porous exterior envelope retains the active material in place, so that the large reserve necessary with other types is here unnecessary.



FIG. 14.  
Tudor Positive Plate for Train  
Lighting. 1/5 size.



FIG. 17.  
Section of Manchester Plate.  
Approx. 2/3 size.

mony-lead alloy furnishes mechanical strength, while small, pure lead, spirally wound "buttons" (Fig. 16) inserted in holes of the grid (Fig. 17) furnish the active material which

The plate consists of a number of cylindrical pencils, one of which is shown in section in Fig. 19; a central-lead antimony core furnishes support and conductivity for the surrounding mass of active material, itself again enveloped by the perforated hard rubber tubes (Fig. 18). The perforations in the tube consist

of minute saw cuts of the order of one one-hundredth inch wide; and so effective are these tubes as "retainers" that the plates which employ them have a life approximating 1,000



FIG. 18.  
Ironclad Positive Plate — Vehicle  
and General Service.  
Approx. 1/5 size.

cycles of charge and discharge, being two to three times that of the flat plates, Fig. 11, in which the active material is left exposed.

The life of the Ironclad plate is thus about the same as that of a Tudor or Manchester plate, while its capacity-weight ratio is about on a par with the pasted types.

With the Ironclad plate loosening and washing out of the active material is reduced to a

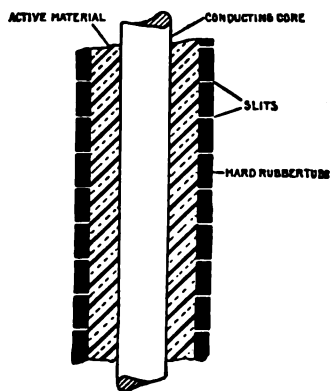

FIG. 19.  
Vertical Section Ironclad Tube  
Approx. 1/2 size.

minimum, and, contrary to what might be expected, the protective rubber tube offers but very slightly increased resistance to the passage of the electric current.

This type of plate, in conjunction with an oxide negative of suitable thickness, is fast becoming standard in this country in all portable service where durability is a prime factor.

**Separators.**— Thus far we have limited ourselves to the question of the plates of the lead battery; but though they undoubtedly constitute the greater problem of storage battery design, yet the manner in which they are assembled is almost as important as the design of the plates themselves; and next in order of importance

come the "separators." Considerations of space, weight and electrical resistance all demand that adjacent positive and negative plates be maintained as close together as possible, yet without touching anywhere. To fulfil these requirements spacers or separators of some sort are inserted between them. Here again countless schemes have been tested out, but to-day practically only two types have survived, and these often used in conjunction.

The older of the two is the perforated rubber separator, shown in Fig. 20, as a flat sheet of perforated hard rubber, and often, when used alone, provided with a series of parallel ridges on one side, to afford sufficient acid



FIG. 20.  
Flat Perforated Rubber Separator  
Approx. 1/5 size.

space between plates. When so used, however, even though the holes be small, "trees" of lead are very apt to develop on the negative plates, which in time find their way through to the positives and cause short-circuits.

The perforated rubber separator used by itself is therefore not satisfactory and has been almost entirely replaced by the wood separator, examples of which are shown in Figs. 21 and 22.

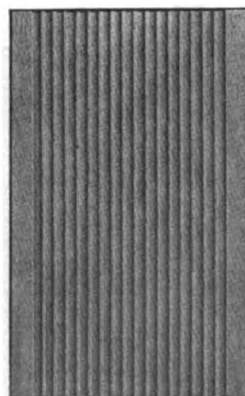

FIG. 21.  
Grooved Wood Separator —  
Vehicle and General Service.  
1/5 size.

In the one case the separator is a veneer about one-sixteenth inch thick, with split wood dowels slipped over it to give the necessary space between plates; in the other it is made of a

thicker piece, grooved, and in either instance treated by a special chemical process. The distinctive feature of the wood separator is that it is not perforated, with the result that short-circuits are practically eliminated, while its electrical resistance is nevertheless almost negligible.

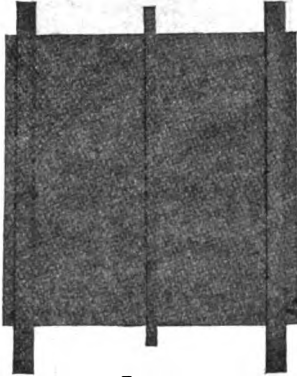

FIG. 22.  
Flat Wood Separator General Stationary Service. 1/10 size.

In many cases the grooved separator and plain perforated rubber are used together, the flat of the wood against the negative plate, this making an excellent combination, used in most of the vehicle propulsion and many other portable batteries.

The flat veneer with split dowels is used chiefly in large stationary batteries, where the grooving would constitute too great a wastage of wood.

**Containers.**—The vessels which contain the complete element — plates, separators and acid — are of three different kinds: hard-rubber jars, where lightness and ruggedness are required, that is, for all kinds of portable service; glass jars for stationary service in the smaller sizes; lead-lined wooden tanks for the larger stationary installations.

**Electrolyte.**—The electrolyte in lead batteries is dilute sulphuric acid of the highest available purity and of strength varying ac-

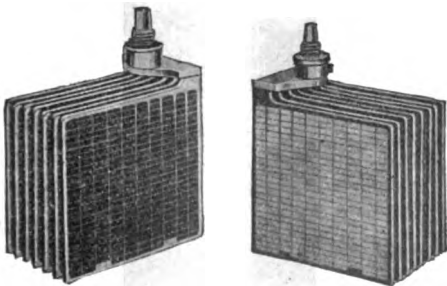

FIG. 23.  
Assembled Plate Groups for Auto Starting Battery of Fig. 26. 1/6 size.

cording to conditions. Where space and weight are of utmost importance, stronger acid, about 1.280 specific gravity, is employed, but where these items are non-essential a greater bulk of weaker acid, say 1.200 specific gravity, answers better, in that it causes less loss from local action, especially on the negative plates.

**General Assembly.**—So much variety exists in the details of assembly employed by different manufacturers and for different purposes

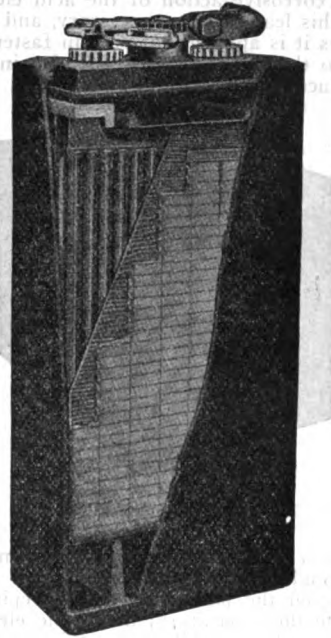

FIG. 24.  
Ironclad Exide Cell for Vehicle and General Service. About 1/5 size.

that it will be possible to mention only a few of the controlling factors and to give a few illustrations of complete cells (Figs. 24, 25 and 28).

In all present-day designs, positive and negative plates are placed alternately side by side, all of like polarity being firmly united into "groups" by means of "lugs" which project from the upper corners. Fig. 23 shows a posi-

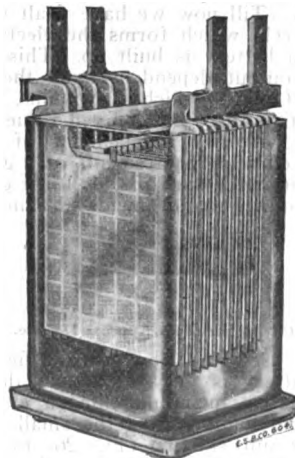

FIG. 25.  
Manchester-Box Stationary Cell. 1/10 size.

tive and a negative group as used in the small auto starting battery of Fig. 26; and these illustrations also show the general manner in which

the plates are united, by a lead welding process, to the connecting straps which form the terminals of the cell.

The corrosive action of the acid electrolyte makes this lead welding necessary, and in most instances it is applied, not only in fastening the plates to the cell terminals, but also in fastening adjacent cell terminals together, so that

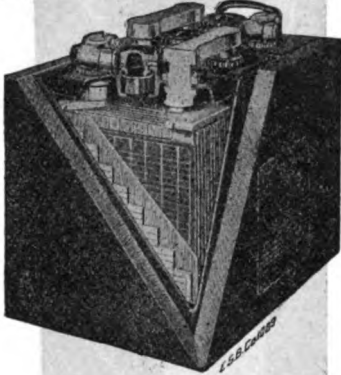

FIG. 26.  
Three-cell Auto Starting Battery.  
Approx. 1/6 size.

there is a solid metallic contact from cell to cell throughout the whole battery.

Between the plates, and thus keeping them apart, lie the separators; the whole element so proportioned as to fill the container, tightly in portable batteries, somewhat loosely in stationary ones.

The plates are usually either supported upon ridges projecting upward from the bottom of the jar (Fig. 24) or are suspended from the top of the jar (Fig. 25) or from the lid or in some equivalent manner.

Tight covers for the containers have to be provided only for portable service; stationary cells are generally left open for ready inspection and access.

**General Principles of Complete Battery Assembly.**—Till now we have dealt with only the single cell, which forms the electrical unit of which a battery is built up. This unit has a current output dependent upon the number and size of plates which it contains, while its electro-motive force has a fixed value, roughly two volts, virtually independent of its size. Hence the current requirements of a given battery determine the size of cells to be employed, and the voltage requirements the number of



FIG. 27.  
Inter-cell Connector — Auto  
Starting Service. Approx. 1/4 size.

cells to be used in series. As the field of the storage battery is very broad, so the design varies greatly, including almost every conceivable combination from the small three-cell battery for auto starting (Fig. 26) to the large central station battery of 150 cells, as shown in Fig. 30.

**Inter-Cell Connectors.**—For connecting the individual cells together electrically various forms of "connectors" and "bus bars" are in use, usually made of lead or lead-antimony alloy, occasionally of copper, protected by a coating

of electro deposited lead. In Fig. 27 is shown a connector as used, not only for auto starting batteries, but for most other portable and semi-

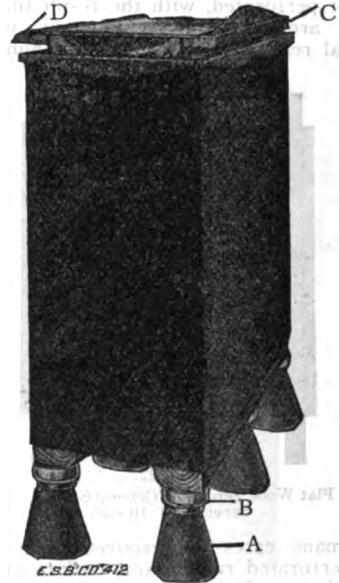

FIG. 28.  
Large Stationary Cell. Stand-by  
Service. Contains 45 plates as in  
Fig. 29. Approx. 1/20 size.

portable types. Composed of lead, or alloy, it is made to fit over the tapered terminal posts (Fig. 23), to which it is permanently secured by means of a hydrogen flame, or its equivalent, which melts the lead of both post and connector till they flow together and become united.

In Fig. 25 there are no connectors proper, the pure lead straps to which the plates are attached having prolongations adapted to be bolted together from cell to cell.



FIG. 29.  
Large Exide Plate for Stand-by  
Service. Each plate 150 amp.  
1 hour. 1/15 size.

In the large stationary batteries the plates of adjacent cells are as nearly as possible welded directly together, each plate (Fig. 29)

having a projecting "lug" which reaches part way over the edge of the cell where all are united to a substantial lead bus bar, as in Fig. 30 and at "D" in Fig. 28. The bus bar "C" in this figure is one of the battery terminals, and the lead is reinforced by a large tapered plate of copper, to which is bolted the copper bar that connects the battery to the switchboard.

In Fig. 30 are shown a number of these terminals with the large coppers leading off. In this instance the battery is so arranged that the number of cells in circuit may be varied

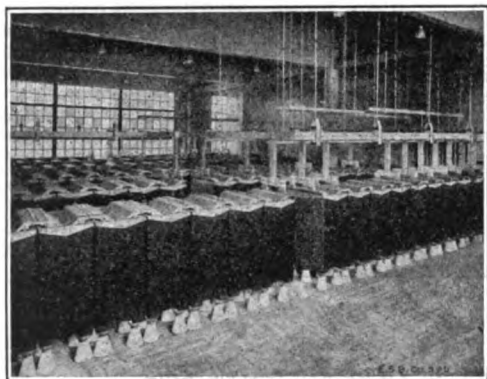

FIG. 30.

Large Stand-by Battery, 150 Cells, 167 Plates (Fig. 29) each. Capacity 12,400 amp. for one hour. Each cell stands about four feet high.

by means of a motor operated "end cell switch," so as to vary the voltage at will, or more usually to maintain the voltage constant by throwing in additional cells as the E M F of each falls off during the progress of discharge.

**Insulation.**—In the small portable batteries, such as the auto starting type, insulation of the individual cells is easily accomplished by the rubber jars themselves, which accordingly are placed side by side in a box of suitable size. When, however, a number of such cells, say 40 or more, are connected in series, as in Fig. 36, it is found necessary to divide the series amongst a number of boxes, or "trays," each one preferably containing not more than 8 or 10 cells.

In small stationary batteries a flat glass tray under each cell is often used, as shown in Fig. 25, a little sand being placed in the bottom to give an even seat for the glass jar. Larger stationary cells are usually provided with double insulation of some kind; thus in Fig. 28 the tank rests upon a glass-oil insulator, "B," which in turn is supported by a large inverted stoneware cup, "A."

**Characteristics of the Storage Battery.**—The primary useful quantities furnished by a storage battery are *electromotive force*, or P.D. (measured in volts), and *current* (measured in amperes); since the time during which a given current may be maintained is frequently of controlling importance there arises a third quantity called the *capacity*, the product of the current and the time which the battery can furnish it. Frequently the relation of these three primary attributes to the weight of the battery is a vital factor; while the effects of internal resistance and temperature are scarcely less

important. The characteristics of a battery therefore consist of the relations of these quantities one with another. In the following discussion the unit considered is in every case a single cell.

In speaking of the discharge of a battery, the term *discharge rate* is very frequently used, commonly expressed in terms of the time during which the discharge can be maintained; the four-hour rate for instance being that rate which the battery can hold for four hours. The so-called "normal rate," originally that for which the battery was intended, is actually of but little significance, since the modern battery may be discharged at almost any rate without injury.

The capacity is limited by the fall of voltage to a point where usefulness ceases, this point being again arbitrary, but through large experience fairly well defined as about 1.60–1.80 for the lead cell, about 0.6–1.0 for the Edison type.

Many variations exist in the design of modern storage batteries, and each design possesses its own characteristics; the curves which follow are chosen as fairly representative, but of course cannot pretend to fit all cases.

**Characteristics of the Edison Cell.**—

**Capacity—Temperature.**—The capacity of a given Edison cell is very nearly a constant quantity independent of the rate of discharge, amounting under ordinary conditions to about 11.5 ampere hours per pound. The capacity is, however, very markedly dependent upon temperature, to an extent which varies with the discharge rate. This variation with temperature is so great that there results a critical point, below which the Edison cell becomes practically inoperative; and since this point is from 30–50° F., depending on conditions, it constitutes one of the chief limitations to the usefulness of this form of battery. If given a chance to discharge rapidly, when slightly below the critical temperature, the battery will gradually warm itself; but for immediate action at low temperatures it is unworkable.

**Voltage—"P.D."**—Fig. 31 shows a typical voltage curve of an Edison cell during its "normal" or five-hour rate of discharge, and during the corresponding charge. At lower rates of discharge the voltage is higher, while at higher rates it becomes lower. Fig. 32 summarizes a number of discharge curves by giving the initial, the mean and the final voltage at rates up to six times the normal. It is noticeable that the voltage falls off very rapidly with increasing discharge rates and that the maximum current obtainable is only about 14 times the normal, while the maximum watt output is reached at about seven times the normal rate.

It is of interest to notice that the mean voltage of the Edison cell is about 60 per cent that of the lead type and that the percentage drop during discharge is about triple with the Edison. It is thus necessary to employ at least 65 per cent more cells of Edison type for a given discharge voltage; and still more than this if the discharge rate be high.

**Efficiency.**—Comparing the mean values of the two curves of Fig. 31 we arrive at the value—72 per cent—as the mean volt efficiency; the corresponding ampere hour efficiency is approximately 88 per cent, while the watt hour, or energy efficiency, the product of these two, is 63 per cent.

In actual practice, the charging is frequently done from a fixed source of voltage equal to or slightly exceeding the maximum, 1.75 in the present case; hence under these conditions, the "commercial" voltage efficiency is but 68 per cent.

Also, in practice the charge required is greater than that shown in Fig. 30, so that

show that at ordinary temperatures and moderate discharge rates the Edison battery may give excellent service. At high rates, or low temperatures, however, its performance is so limited that it is now seldom used where such conditions prevail. It is these conditions which have excluded it entirely from the field of auto self-starting; while on the other hand, in other

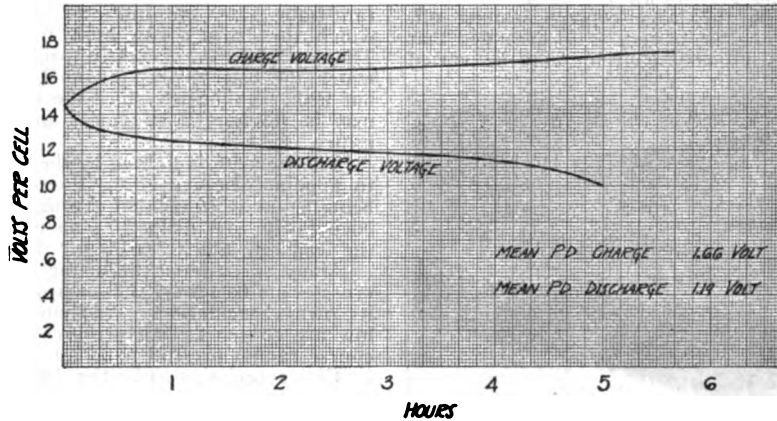

TYPICAL CHARGE & DISCHARGE CURVES OF EDISON CELL-NORMAL RATE

FIG. 31

actually the ampere efficiency is about 80 per cent. The commercial watt hour efficiency of the Edison battery, where worked to its full capacity and charged from a source of constant voltage, is thus found in actual practice to average hardly above 55 per cent. Where charged from a source of variable voltage, and where worked to partial capacity only, the effi-

service, as for instance, train lighting and mine lamps, it has proved very satisfactory.

**Characteristics of the Lead Cell.—**  
**Capacity.**—The capacity of a given lead cell is mainly dependent upon two variable factors: (1) the rate at which it is discharged, and (2) its temperature.

1. The effect of varied discharge rates is

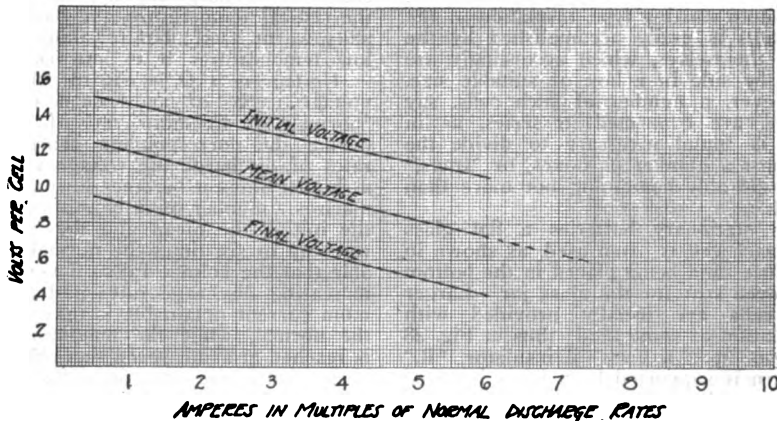

VOLTAGE CHARACTERISTICS OF EDISON CELLS

FIG. 32

ciency may be much higher, depending on actual conditions.

**Capacity and Weight.**—The energy capacity of the Edison cell at normal rate and temperature is about 14 watt hours per pound. With higher rates, or lower temperatures, this value falls very markedly.

**Summary.**—The characteristics noted above

shown by the curved line in Fig. 33, from which it will be seen that the capacity varies inversely with the rate, though not in direct ratio. While the abscissæ of this figure show the discharge rate in terms of the normal, vertical lines at intervals give the rate in terms of the duration of discharge.

The shape of this curve is very characteris-

tic of all lead batteries, though differences in design modify it appreciably. Thinner plates tend to give a flatter curve, thicker ones a more sloping one.

A very important corollary of the variation of capacity with rate exists in the fact that a lead cell which has been completely discharged at a high rate, if allowed to stand for some hours, will largely recover, so as to give a considerable further discharge. In the case of a continuous discharge of diminishing rate, the ultimate capacity approaches that which would have obtained had the final rate been maintained throughout. In the operation of an electric vehicle the rates on starting, up grades, etc., exceed the normal rate by five to one or more; yet owing to the periods of rest, or low rate, the capacity attainable is practically identical with that of a continuous normal rate discharge. The normal rate for batteries of this kind is usually that corre-

proaches a slanting straight line. Referring again to Fig. 33, the three upper lines, with the scale of ordinates at the right hand side, summarize the effect upon voltage of various discharge rates up to 10 times the normal. It is of interest to note that at 10 times normal the mean voltage has lost but 20 per cent; that the maximum watt output occurs at about 25 times normal; and that short circuit gives about 50 times normal discharge current. Comparison between these curves and the corresponding ones for the Edison battery, Fig. 32, is very significant. The Edison battery is inferior (a) in that it has a much greater percentage drop in voltage during discharge at any given rate, and (b) in that the lead battery can discharge at about three times as high a rate as the Edison.

2. *Acid Change ("Gravity").*—It has been pointed out in discussing electric-chemical equations, that the amount of free sulphuric

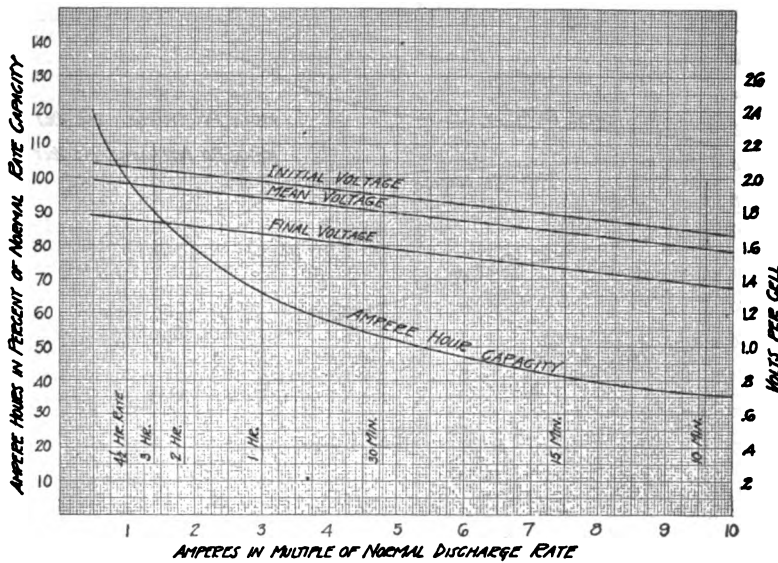

VOLTAGE vs CAPACITY CHARACTERISTICS OF LEAD CELL

FIG. 33.

sponding to a continuous discharge of four or five hours.

2. Temperature at time of discharge exercises a direct influence upon capacity to the extent of about 6½ per cent per 10 degrees F. It thus comes about that at 0° the lead battery has about 54 per cent normal capacity, and that it is perfectly workable at temperatures much lower even than this, especially where the discharge rate is lower than normal.

**Discharge Phenomena.**—1. *Voltage (or PD).*—Of equal importance with the capacity of a battery is its voltage characteristic, a typical curve of which is shown in Fig. 34. Starting off at approximately two volts, there is a gradual falling off, till the end approaches, when the voltage rapidly drops below a useful value. The curve shown is for the normal rate, but is fairly indicative of the general behavior of a lead cell on discharge. With higher rates, however, the curve is lower throughout its length, and more nearly ap-

acid varies as discharge proceeds, and the third curve of Fig. 34 shows for a particular case what this change amounts to. Barring the fact of a lag at the start, the change of acid, measured by hydrometer, varies directly with the ampere hours drawn from the cell; but the amount of change depends so entirely upon the relative volume of acid contained in a given cell, that the numerical values of this curve in Fig. 34 have no general significance.

3. *Temperature Change.*—The lead cell to a slight extent is a thermo-electric accumulator, inasmuch as a slight disappearance of heat accompanies the discharge. This phenomena is graphically shown in the lower curve of Fig. 34, where it is seen that the temperature dropped 9° F. during discharge. At higher rates, the heat generated by internal electric friction overbalances that absorbed, and at the one hour rate the temperature rises about to the same amount as it dropped at normal rate. The absorption of heat on dis-

charge, while of much theoretic interest, is of little practical value.

**Internal Resistance.**—One of the most valuable attributes of the lead battery is its high conductivity, which enables it to yield up its stored energy at extremely high rates. It is impossible to state the resistance definitely owing to variation of design; but by way of illustration it may be said that a cell of the type from which Fig. 34 was taken, having a normal rate of 35 amperes, has an internal resistance of about .0014 ohms at beginning, and .0028 ohms at end of discharge. Since it is mainly through its influence upon voltage that internal resistance is of interest, the data furnished by the curves of Fig. 33 give the practical information required better than an attempted formula for calculating resistance.

**Efficiency.**—During charge, the P. D. of a lead cell starting at about two volts rises gradu-

ditions, the volt efficiency is about 75 per cent, the watt hour efficiency about 65 per cent. These conditions are the most prevalent, except when a battery is charged directly from a generator, whose voltage is made to vary according to the charging curve.

**Capacity Weight Ratios.**—The capacity per unit weight of lead storage batteries varies all the way between 1.4 ampere hour per pound of cell in the heavier stationary types, such as Fig. 25, to about 5.5 in the lightest thin plate types for portable service, Fig. 26. These figures, as a basis of comparison, refer in all cases to a discharge rate approximating the five-hour. To find the corresponding values for other rates, reference should be had to the capacity curve of Fig. 33, bearing in mind that 100 per cent in this figure corresponds to an actual capacity of 4.6 ampere hours per pound.

Since the mean discharge voltage under

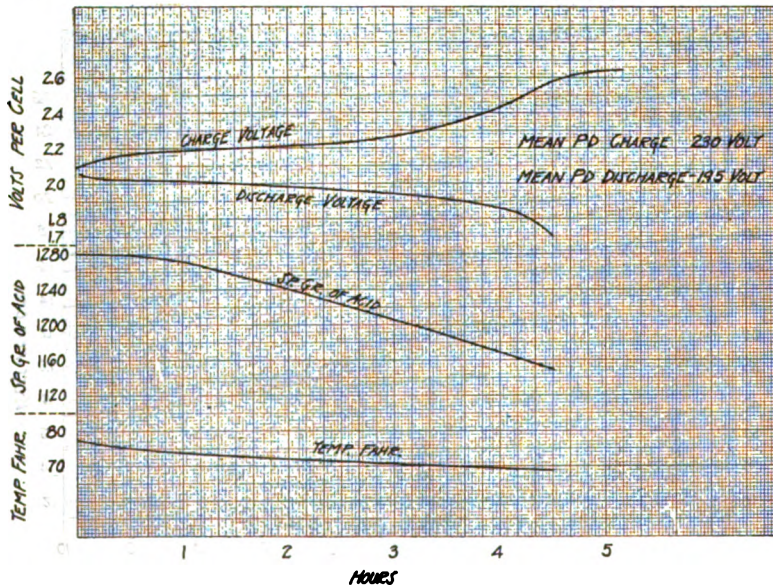

TYPICAL CHARGE AND DISCHARGE CURVES OF LEAD CELL-NORMAL RATE

FIG. 34.

ally and finally becomes constant at a rather indefinite value, from 2.5 to 2.6 volts, following the general trend of the upper curve of Fig. 34. The mean height of this curve is 2.3 volts; that of the discharge curve 1.95 volts. Hence the volt efficiency is 85 per cent.

In commercial operation, it is found necessary that the charge exceed the discharge by about 15 per cent, so that the ampere hour efficiency is about 87 per cent, the watt hour efficiency about 75 per cent. When worked to less than 100 per cent capacity, both voltage and current efficiency are higher; so that in such cases it may reach or even exceed 90 per cent, as in regulating service, where charge and discharge succeed each other rapidly and for a few minutes duration only.

Where a battery is charged from a fixed voltage, on the other hand, this voltage must at least equal that at the end of the charge; hence where worked to full capacity under these con-

ditions is approximately 1.95 it follows that the energy capacity of a conservatively designed battery for portable service (as in Fig. 24) is about 9 watt hours per pound; for the lightest types in commercial use (Fig. 26) about 11.

It is a prevalent and quite natural idea that because the ordinary storage battery is made of lead, it is therefore unduly heavy. But when it is stated that each pound weight of battery can store up 24,000 foot-pounds, it may be readily appreciated that the electric storage battery of to-day is by far the most effective piece of mechanism known for storing energy. Put in slightly different form, it may be stated that the modern battery of conservative and substantial design, as in Fig. 24, can give out, in the space of five-hours, electrical energy sufficient to lift itself approximately five miles high.

**Care and Operation.**—To give a complete treatise on battery operation, covering the whole



varied field to which batteries are applied, would be beyond the scope of this article; but a few fundamental principles which are applicable to all cases may be briefly stated.

**1. Care of Electrolyte.**—Evaporation of the water of the electrolyte is constantly taking place, especially while the cell is gassing freely at the end of charge; this must be made up by periodic additions of water. Since the amount of water thus added during the life of a battery is many times the original amount contained, any impurities in the water accumulate quite rapidly. Hence it is very important to use only pure water for this purpose, and among the impurities commonly present chlorine and iron in any form are especially to be avoided. Addition of acid should be avoided.

**2. Regulation of Charge.**—If a battery be habitually charged too little, the active material becomes gradually more and more converted into lead sulphate, until in time it ceases to function. Very long continued charge is then necessary to restore it to a working condition. If on the other hand it be charged too much, the gas bubbles liberated from the plates give rise to a softening and eroding action upon the positive material, which detaches it from the plates, and in time leaves the grids bare, and no longer workable. Experience has demonstrated that best results are obtained when each charge exceeds in ampere hours the previous discharge by about 15 per cent.

Several methods are in use for determining the correct amount of charge, as follows: (a) The "ampere hour" metre shows directly, both the current withdrawn on discharge and that put in on charge, from which the latter may be regulated; a very generally effective method when the discharge current is not too low, say 10 per cent of the normal. (b) The battery may be charged till the voltage ceases to rise; one of the older and less reliable methods. (c) The best indication of the state of charge is that based upon specific gravity of the electrolyte. If the specific gravity be read at regular intervals during charge, it will be found to rise steadily for a time, and then become constant.

When three successive readings covering a period of about an hour show no change in gravity, it means that chemical action between plates and electrolyte has ceased, and hence that the charge is complete, and should be stopped.

This method of determining charge is far the most reliable, and should be used wherever possible; and in any case should be used from time to time, to check up and make certain that charging is being done correctly. A single cell is usually selected as a "pilot" for taking readings with this method.

While the life of a battery may be much increased by careful regulation of the charge, according to the above principles, yet many hundreds of thousands of batteries are in successful operation, where the only care observed in charging is to arrange that it is ample, regardless of other considerations.

The strength of electrolyte used in storage batteries is not standardized, but varies with different makes and designs, and even with the individual cells of a given battery. In general where weight is a prime factor, higher gravity, usually about 1.280 specific gravity, is used; where weight and bulk are not important lower gravity, 1.200 or even 1.180, are preferably em-

ployed. In the former case the volume of acid is small, and the drop of acid during discharge is correspondingly large, so that in discharged condition it may be 1.150; in the case of a stationary cell, where there is no close limit to bulk, the acid which reads perhaps 1.200 on charge will drop during discharge to about the same point as the other, namely, 1.150-1.170. It is thus impossible to give any generally applicable values for the specific gravity of the electrolyte, but the theory of charging till a maximum is reached holds universally true.

The specific gravity of sulphuric acid of the concentration used in batteries varies with temperature, a rise of 10° F. causing a drop of .003 specific gravity; and as a matter of reference it is usual to correct all readings to 70° F.

**Applications of the Storage Battery.**—The field of the storage battery to-day is so broad that a few of the most important applications only may be enumerated, as follows:

**Propulsion of Automobiles and Commercial Trucks.**—Usually 40 or 42 cells, capacity of 100-250 ampere hours, type of cell as per Fig. 24.

**Propulsion of Mine Locomotives.**—40-88 cells, 200-300 ampere hours capacity. Fig. 36.

**Propulsion of Small Industrial Trucks.**—Usually 12-16 cells, 100-200 ampere hours capacity, type of cell as per Fig. 24.

**Propulsion of Submarine Torpedo Boats,** while running submerged.—Usually 120 cells, 4,000-14,000 ampere hours capacity.

**Electric Lighting of Railway Trains.**—Each car equipped with a battery, usually 16 cells, 150-350 ampere hours capacity. Fig. 35.

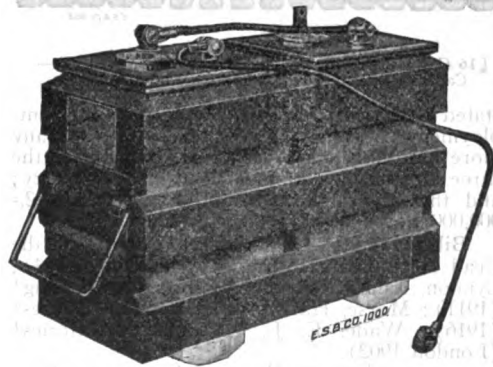

FIG. 35.

Two Cell Unit of Train Lighting Battery, which consists of 16 Cells in all. Approx. 1/10 size.

**Starting and Lighting of Automobile.**—Usually 3 cells, designed to give 150-250 amperes for short intervals of a few minutes duration. Fig. 26.

**Airplane Motor Ignition.**—Usually 4 small cells, to insure motor reliability.

**Mine Lamps.**—One or two cells, 8-12 ampere hours capacity.

**Railway Signal Service,** for operating the signals which control the movements of trains.

**Wireless Telegraphy** as the source of power, both ashore and afloat, in army and navy, as well as commercial service.

**Telephone Stations** furnishing power for the telephone systems. Practically every central is provided with a battery, charged from a small dynamo, and for the purpose of assuring con-

tinuity of operation. Batteries from 15 to 2,400 ampere hours capacity; Fig. 25 shows a typical cell.

*Light and Power Plants*, in great variety. Fig. 37 shows a small 16 cell battery, charged from a low power gasoline engine and dynamo,



FIG. 36.

Electric Locomotive Battery, 48 Cells, 21 Plates each, capacity 210 amperes for 1 hour. Approx. 1/25 size.

and suitable for lighting the buildings on a farm. Fig. 30 shows a mammoth size central station battery, used as a reserve or stand-by in connection with a large central power station.

Between these extremes, batteries of all kinds and sizes are employed, in steam, water and oil operated power plants.

As an indication of the importance of the storage battery in the United States, it may be



FIG. 37.

16 Cell Battery for Small Isolated Lighting Plant.—Capacity 8 amperes for 8 hours. About 1/30 size.

stated that their manufacture gives direct employment to some 14,000 persons, with many more indirectly employed; that it is among the three largest consumers of lead in the country; and that the annual output approximates 2,000,000 horse power hours capacity.

**Bibliography.**—Dolezalek, 'Theory of the Lead Accumulator' (tr. by Van Ende, 1904); Lyndon, Lamar, 'Storage Battery Engineering' (1911); Morse, Harry W., 'Storage Batteries' (1916); Wade, E. J., 'Secondary Batteries' (London 1902).

EDWARD WANTON SMITH, CH.E.,  
Factory Engineer, The Electric Storage Battery  
Company, Philadelphia.

**ELECTRIC STORM**, a sudden and violent change in the normal magnetic currents of the earth, with oscillations of potential, interfering with the action of telegraph and telephone instruments, sometimes suspending their operation and even diverting the current so as to stop trolley cars; called also magnetic storm. Without any advance warning the magnetic needles will swing a long way out of normal positions, because of the disturbed earth currents. The electric potential of the earth is ordinarily stated as zero, and all electric currents are measured from that basis or standard, which represents the balance that electricity seeks. The earth is a huge dynamo, with magnetic currents continually flowing, and it will absorb any amount of electric current that the machines

of man can collect without any apparent effect on this vast storehouse of nature. But the sun is also a natural dynamo, of vastly greater activities and subject to electric stresses of a violence far transcending anything we have or can experience on this earth. One of the apparent effects of the electric and chemical activities of the sun is displayed in the sun-spots, which occur there with irregular frequency, appearing to come and go in undetermined cycles. The cause of these sun-spots is largely conjectural, but the view is generally accepted that they represent openings or vortices in the outer gaseous envelope of the sun. However this may be, it is apparent that they are in some way connected with the electric storms or violent changes of magnetism that occur on the earth. These electric stresses occur at intervals that cannot be predicted, but are comparatively frequent, and perhaps once or twice a year the violence of the magnetic changes is sufficiently abnormal to be characterized as a great storm, which for a short time paralyzes the action of more or less electric machinery, much as a great storm of wind and rain paralyzes the traffic of a large city.

For the past 25 years or longer many scientists and a number of observatories have been more or less engaged in studying the phenomena of these storms and have striven to formulate a correct theory of their origin and progress. The difficulty is not that reasons cannot be found for such irregularities of the earth's potential, but rather that there are so many plausible explanations which cannot all be true, that the investigators are puzzled which clues to follow. Early observations disclosed a periodicity in the electrical storms, that clearly tended to follow the displays of sun-spot activity. If these spots were the direct cause it would be reasonable to expect the following electrical storm on the earth to come at a definite interval; but the fact is that an electric storm always lags behind the sun-spot activity, and lags all the way from a few hours to a few days. While the average lag is about 38.4 hours, the lag in great storms is only about 20 hours, indicating that the more violent the influence the swifter the travel.

Another sort of evident periodicity in electrical storms is their recurrence at periods of about a month. Some observers have figured numerous intervals corresponding with the lunar month, while others have noted a close correspondence with the synodic months of 29 and a fraction days, this synodic month representing the dates on which the earth, sun and moon come almost or quite into a direct line. This suggests that the storms are influenced by the sun and moon jointly, or that in some way the moon directs these extraordinary electric activities of the sun toward this planet.

Certain other well-established phenomena have been established with reference to these storms. Not only are they coincident with sun-spots to a marked degree, but also with displays of the aurora borealis or "northern lights." Evidently the aurora is but a visual evidence of magnetic disturbance. Another pertinent fact discovered is that the magnetic storm is about twice as apt to occur in the nighttime as in daylight, which is accounted for on the supposition that the rays strike the earth's atmosphere at a great height and are deflected

by the earth's magnetic currents, being mainly manifest on the hemisphere opposite the sun. They are by no means confined to the dark hemisphere; in fact they frequently strike the earth and circle it several times before their force is spent. Prof. L. A. Bauer, of the Carnegie Institute at Washington, discovered that in two great electrical storms (in 1902 and 1903) the magnetism circled the earth at a speed of about 7,000 miles a second, requiring  $3\frac{1}{2}$  to 4 seconds only to complete the circumference. It had previously been supposed that all magnetic needles felt the storm at the same instant. He not only demonstrated this travel, but showed that some storms traveled from west to east, others from east to west. Other things we know about electric storms are that the smaller storms are comparatively local, being termed equatorial storms and polar storms according to the portion of the earth's surface affected. There are also types recognized as positive and negative storms.

Within recent years a new theory has developed, which may be summed up with the idea that pencil-shaped emanations or shafts of Roentgen or cathode rays, or perhaps of negatively charged particles, are shot out by the sun during periods of sun-spots, and that when the earth runs into one of these the effect here is an electric storm. This hypothesis assumes that the same electric activities that produce sun-spots also produce these pencil-shaped shafts of rays and not that the sun-spots are responsible for them. Professor Bauer points out that the fact that electric storms may travel in either direction around the earth is against this pencil-like shaft theory, as these should intercept the earth always in the same way. The professor has also noted that these storms seem to break at a height of about 75 miles in the earth's atmosphere and that as they come closer to the surface their effects are felt more severely. He contends that the energy of electric storms is supplied by the earth itself and not by the sun or sun-spots; that the same activities in the sun that cause sun-spots, set in motion the electric storms very much as a trigger sets in motion the activities of the powder in a gun.

Prof. Kr. Birkeland, of Christiania, has made exhaustive experiments with vacuum tube apparatus of his own designing, in the effort to prove the theory of cathode ray origin or something similar. He has succeeded in duplicating much of the phenomena of the electric storm and made many valuable records, but his theories have not been generally accepted.

**ELECTRIC STRESS**, the force that causes the deformation of the surface of a substance within an electric field.

**ELECTRIC SUNSTROKE**, a stroke that prostrates a person in a manner resembling sunstroke, brought on by prolonged exposure to a strong electric light.

**ELECTRIC TELEGRAPH**. See TELEGRAPHY.

**ELECTRIC TELEGRAPH CABLE**. See CABLE; TELEGRAPHY.

**ELECTRIC TELEPHONE**. See TELEPHONE.

**ELECTRIC TENSION**. See ELECTRIC BATTERIES; ELECTRICITY; ELECTRO-MOTIVE FORCE.

**ELECTRIC TORPEDO**, a torpedo operated by electricity. There are various kinds of electric torpedoes. The Sims-Edison torpedo is driven by an electric motor and its motions are controlled from the shore by electricity. The torpedo proper is carried some distance below the surface of the water by a vessel immediately above it, from which it is suspended by two rigid bars. In the torpedo is a cable reel on which the conducting cable is disposed. An electric motor and controlling gear are also contained within the torpedo. In its front the explosive is placed. It is driven by a screw propeller actuated by the electric motor. As it moves it pays out cable so that it has no cable to draw after it through the water, the cable lying stationary in the water behind it. This avoids frictional resistance to its motion. The maintenance of the torpedo at a proper depth is one of the advantages of the system over other methods.

**ELECTRIC TRANSMISSION OF ENERGY, Long Distance**. An electric transmission of energy obviously occurs when the relay of a Morse telegraph circuit, or the sensitive mirror used in submarine cable telegraphy, responds to the feeble current impulse originated at the transmitting end of the wire. It is also obvious that we have the electric transmission of power in the ordinary use of electric light or electric motors even when the generator is stationed in the building in which that light or power is used. But generally speaking the term electric transmission of energy denotes the transmission of energy on a large scale by means of overhead or underground conductors or cables and its transformation into light, heat, chemical energy or mechanical power at the remote end of the conductors. When the distance to which this electric power is transmitted exceeds say 15 or 20 miles it is usually spoken of as the long distance transmission of electric energy or power.

In cities like New York where electric energy for lighting, power and railway traction is transmitted distances ranging from less than a mile to 15 or 18 miles from the power house the conductors are usually placed in cables in underground conduits and the maximum electromotive force transmitted is about 11,000 volts. This pressure is directly generated by a steam-driven alternating current generator and is transmitted over the conductors to sub-stations, where by means of step-down transformers the pressure is dropped to say 600 volts alternating current which when direct current is desired by rotary converters is converted into direct current for the street mains, the feeders of the railway system and for charging storage batteries which in turn give out direct current at times of heavy demand or when otherwise required; or when alternating current is required for service mains the 11,000 volts is transformed to say 240 volts. When water power is available, as at Niagara Falls and innumerable other places in this and other countries, the electric transmission of power on a large scale to distances of 25, 50, 100 and 200 miles from its source is not uncommon.

In order that electric power may be transmitted economically to long distances the use of high electric pressure or tension is essential, since otherwise the cost of copper in the conductors would be excessive. For example: It

has been calculated, on the basis of 5,000 volts, that to transmit 2,356 kilowatts a distance of 100 miles would require about 22,862,737 pounds of copper in the conductors, assuming a line drop of 750 volts, or 15 per cent of the total electro-motive force, whereas with 40,000 volts the total amount of copper required would be about 357,230 pounds. Even doubling the pressure would quarter the amount of metal required for a given distance and given line drop. In the electric transmission of power to long distances the use of alternating current is general, and transformers are utilized to increase the electro-motive force on the transmission line and for reducing it at the points of distribution. Where the electro-motive force on the line does not exceed 10,000 volts generators developing that electro-motive force may be employed. When that line voltage is exceeded the station voltage adopted is about 2,300 volts; this being stepped up by transformers to the electro-motive force desired on the line. This moderate voltage admits of the use of lighter copper wires or conductors in the station apparatus than higher voltages would require. In present day practice, however, the use of 150,000 volts is not uncommon and line insulators and transformers to withstand this pressure are now employed. Indeed, manufacturers are prepared to supply transformers capable of operating at 200,000 volts. In North Carolina and South Carolina over 1,000 miles of 100,000-volt transmission circuits are in operation on the system of the Southern Power Company, which derives its power mainly from hydro-electric developments. In California there is a 150,000-volt circuit from Big Creek to Los Angeles, a distance of 240 miles, on the system of the Pacific Light and Power Corporation. The conductors of this circuit are supported on steel towers. In addition this company has in operation 105 miles of 60,000-volt circuits, 240 miles of 50,000-volt circuits and 831 miles of 15,000-volt circuits. These last circuits are supplied with current from the 150,000-volt circuits at various distribution points by means of step-down transformers in sub-stations.

Modern usage in the matter of type of alternating current employed leans largely toward three-phase. (See ELECTRIC ALTERNATING CURRENT MACHINERY). For each circuit this requires three conductors which are arranged on the poles and cross-arms usually in an equilateral triangle, the wires being separated from one another by a distance of six or eight feet. The wires are in some cases transposed on the poles, to form in effect a long horizontal spiral. This is generally done to prevent inductive effects on the telephone wires used for signaling on the same or adjacent poles, although some engineers also think that spiraling the conductors diminishes the impedance of the circuit. So far as the telephone line belonging to the transmission company is concerned the simplest way to avoid inductive effects is to spiral the telephone circuit. While, as just intimated, the long-distance transmission of energy is carried on chiefly by means of the alternating current, transformers, etc., high potential transmission in at least one instance in Europe has been effected with continuous current. In this instance the line pressure is 60,000 volts, which is generated directly on the line by six dynamo

machines in series, each generating 10,000 volts. At the point of distribution six motors are connected in series and each motor is caused to drive a generator which in turn develops electrical energy of a desired potential and current output.

For the supports of the transmission line the choice is practically between the use of wood poles or steel towers. The kind of wood employed for the poles varies somewhat with the locality, cedar being used in the northern States and redwood in the Pacific Coast States. These poles must be of sufficient height to afford ample clearance from ground and sufficiently strong to withstand wind strains, etc. Poles fitted to meet these requirements and to carry two three-wire circuits should be at least 35 to 40 feet in height, set 5 to 6 feet in the earth and be 12 to 14 inches in diameter at the butt and at least 8 inches at top. The use of steel towers permits longer spans and consequently diminishes the total number of insulators necessary. With wooden poles the maximum length of span is 180 feet; minimum 80 feet. With steel towers using 12 to the mile the span between towers is 440 feet. On one long-distance transmission the towers are made up of four galvanized angle iron posts 40 feet in length, 3 inches by 6 inches with three-sixteenths inch angles, the posts being stayed with suitable angles and cross rods.

For the very high potentials used on long-distance transmission lines extra precautions as to insulation are requisite, both where the wires leave the power-houses and on the poles or towers. For insulating the conductors from the poles or towers large porcelain discs are now commonly used, in a series of four or more (arranged somewhat like Japanese dinner gongs), termed suspension insulators, the upper disc of which is attached to the pole or tower. The conductor is attached to the lowest disc. Much care is required in the manufacture of these insulators. This series arrangement of insulators has largely increased the amount of electro-motive force that can be successfully

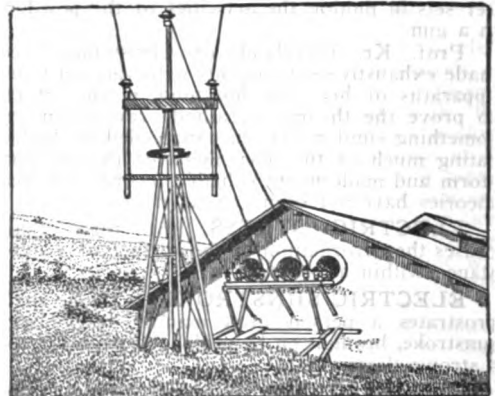

Power House Terminal of Transmission Line.

employed in electrical transmission of power as the electric potential is divided between the individual discs. Other types of insulators for high tension service consist of large petticoat insulators about 12 inches in diameter across the top, 12 inches in height and weigh 18 to

20 pounds. They are supported on the cross-arms or on the pole itself by wooden or iron pins. For pressures up to about 25,000 volts wooden pins are found fairly satisfactory, but above that pressure they are found to char by a peculiar action of the current, and it is advisable on this account, as well as for mechanical reasons, to employ cast iron or metal composition pins. These pins are from 15 to 17 inches in height and they maintain the insulator about 12 inches from the pole or cross-arm. (See illustration, which shows an iron tower, a three-wire circuit, with cross-arms, pins and porcelain insulators; also the openings in the gable of power-house by which the high tension conductors pass out).

The choice of metal for the conductors in this service is virtually confined to copper and aluminum. It is known that there is a tendency to a brush discharge, termed corona, in the air between conductors conveying currents at high pressures that leads to a waste of electric energy when with wires of given diameter a critical electromotive force is reached. The critical electromotive force also varies with the distance between the wires. It was at one time thought that this effect would constitute the limiting factor in the long-distance transmission of electric power, but in Prof. Harris J. Ryan's paper, 'Conductivity of the Atmosphere at High Voltages' (consult 'Proceedings' American Institute Electrical Engineers, Vol. XXI, No. 3), he shows that, regardless of the metal employed, by increasing the diameter of the conductors, whereby the electric gradient is kept below the breaking down point of the air in the vicinity of the wire, this effect is avoided. For example, to avoid atmospheric losses between conductors separated by an air space of four feet, with barometric pressure of 29.5 inches of mercury, temperature 70° F., the conductors must have, for an operating electromotive force of 50,000 volts, a diameter of at least .058 inch; for 100,000 volts, .192 inch; for 150,000 volts, .430 inch; for 250,000 volts, .990 inch. On this account it has been deemed advisable in numerous cases to employ aluminum conductors, since weight for weight its diameter is much greater than that of copper.

For instance, on a 150-mile line in California transmitting 745 kilowatts (10,000 horse power) at 40,000 volts, aluminum conductors seven-eighths inch in diameter are used. In a 100-mile, 60,000-volt transmission line in Mexico a copper wire three-eighths inch in diameter is used. The transmission line from Shawanigan Falls to Montreal, Canada, employs aluminum conductors carrying 12,000 horse power at 50,000 volts. Steel-cored aluminum conductors are also used for this purpose and in some of the latest high tension transmission lines steel-cored copper conductors are utilized.

To provide a system that will be as nearly absolutely reliable as practicable duplicate circuits are in the majority of cases constructed, in order that if one circuit becomes inoperative the other may immediately be brought into service. In some cases the two circuits are erected on one set of poles. In others two separate pole lines are built.

Wherever possible private rights of way are obtained for the transmission line and it is of advantage to have this way so wide that danger from falling trees shall be avoided. Rights of

way along steam railway tracks are not considered desirable for the reason that the smoke from the engines very soon so impairs the insulating quality of the insulators that frequent cleaning and washing of the insulators is rendered necessary. Even on private routes the cleaning of the insulators is at times essential to maintain the insulation.

The distance to which electric energy can be profitably transmitted from a source of electric power is not yet definitely determined. Much depends on the cost of fuel at the distributing points and the amount of energy to be delivered. In California, where coal is dear, electric energy is now being commercially transmitted from a number of water-power plants in that State to an amount exceeding 100,000 horse power at a pressure of 40,000 to 60,000 volts and to distances ranging from 50 to 230 miles. In Switzerland electric energy from water power is transmitted to the point of consumption and sold at \$20 per horse-power hour per annum. There the price of coal is \$6 to \$8 per ton, but labor is cheap. Electric energy generated by the force of falling water and transmitted 85 miles by wire is sold in Montreal, Canada, at \$15 per horse power per annum at a profit. But while as stated the distance to which electric energy may be commercially transmitted is yet undetermined, calculations have been made by reputable electrical engineers which indicate that under proper conditions electric power may ultimately be profitably transmitted in large quantities, say 200,000 kilowatts, and at a pressure of 170,000 volts, to a distance of 500 miles. This transmission would entail the employment of copper wires of a diameter so large that the dissipation of energy by brush discharges between the conductors would be avoided. Should this conception be realized it would obviously bring New York, Chicago and other large cities within reach of the electrical energy developed at Niagara Falls. Indeed the calculation just referred to was based upon the amount of mechanical power utilized in New York. Consult 'Proceedings American Institute of Electrical Engineers, December 1904.' See POWER, TRANSMISSION OF.

WILLIAM MAVER, JR.,

*Consulting Electrical Engineer.*

**ELECTRIC UNDERGROUND CABLES AND CONDUITS.** In the first attempts to operate the electric telegraph, over 60 years ago, both in this country and in Europe, the wires were placed in cables underground; but owing to imperfection in the methods of insulating the wires, as well as in the type of conduit or pipe employed, and of the manner in which the conduits were laid in the earth, the cables and conduits failed after comparatively short service and the use of overhead wires supported on poles was resorted to and became the universal practice, which continued almost without interruption for a quarter of a century.

Beginning about 1890, however, there has been a movement in all the principal cities of America and Europe to place all electric wires underground in order that the streets may be freed from the encumbering poles and overhead wires. In New York city, especially, the movement to this end was carried on vigorously and persistently, with the result that for many years

there has not been a pole supporting telegraph, telephone, electric light or trolley wire in any part of Manhattan borough, such wires all being placed in cables in conduits under the surface of the streets.

**Electric Underground Cables.**—The type of underground cable used for telephony, telegraphy and electric light and power purposes varies greatly. For example, the conductors used in telephony have a diameter of .040 inch; those for telegraph purposes about .080 inch; those for electric light and power range from one-quarter of an inch to one inch and over in diameter. The smaller electric power wires are employed in high potential and comparatively light current work; the larger wires in low tension and heavy current work. It is thus feasible to place about 400 telephone conductors, or 100 telegraph conductors, in one cable in a three-inch underground duct or pipe, while it is only practicable to place two, three, or, at most, five electric light or power conductors in a similar duct. The insulating material used for telephone conductors is usually a wrapping of tissue paper in narrow strips, laid on spirally over each conductor. The insulating material of telegraph underground cables is usually a rubber compound or strips of paper saturated with oils, the thickness of the *wall* of which is about .038 inch. The insulating material of electric light and power cables is usually a rubber compound, oil paper or varnished cambric, which is from one-eighth of an inch to nearly half an inch thick, depending on the electric pressure to be withstood, which, in the case of low potential circuits, is about 220 to 600 volts, and in the case of high potential circuits may range from 1,000 to 30,000 volts. Gutta-percha, which has been employed for the insulation of long submarine cables, is not used for underground cables, owing chiefly to its low softening point under heat, 120° F., which temperature is not infrequently encountered in subways in cities.

Cables designed for underground work are encased in a lead envelope to protect the insulating material from water, moisture and the effects of gases, acids, etc., in the underground conduits. For crossing rivers such cables are also armored with iron wires in addition to the lead covering, as a mechanical protection.

The term cable includes the conductor ("core"), the insulating material, the lead covering and the armor when the latter is employed. Copper is practically the only metal used for the conductors of electric cables. Aluminum is not used because of its bulk for a given conductivity, which bulk is about 1.6 greater than copper. The increased amount of insulating material and lead covering, as well as space in the conduits, that would be required in the case of aluminum for a given conductivity would be virtually prohibitive of its use for underground cables.

The copper wire used in cables is drawn to the required size in the wire factory. If the wire is to be insulated with a rubber compound it is "tinned" to prevent any chemical action between the sulphur used in the rubber compound and the copper. When the covering is paper, linen or fibre the wire is not tinned. The tinning process consists in passing the wire through a vat of molten tin. For electric light and power cables, when the conductors do not

exceed .204 inch diameter, they are usually solid, or of one wire; above that size they are generally stranded to obtain flexibility. The wires are stranded in a stranding machine in one process, the wires being wound on reels, which are held on suitable spindles on the frame of the machine. A single wire is held in the centre of the frame and is slowly drawn through a guide. The wires for the first layer are wound spirally around the central wire; the wires for the second layer are held on another frame and are laid over the first layer in an opposite direction, and so on for the additional layers required. The strand is wound upon a drum and is then ready for the insulating process.

**Rubber Insulation.**—The rubber used in the insulating material for cables is pure Pará rubber. After the rubber has undergone treatment by washing and kneading to remove the impurities which it always contains in its crude state, it is then mixed, by suitable machinery, with the ingredients that go to make up the compound, such as litharge, whiting, blue lead and sulphur. The compound is then ready for placing over the wire. There are two general methods by which this is done, termed, respectively, the seam and seamless methods. In the seam process the rubber compound is calendered into a sheet of any required thickness, which is then cut into long strips. These strips are then passed between two grooved rollers having sharp cutting edges. The wire to be covered also passes in the centre of the grooves of these rollers, and as it does so the rubber strips are pressed closely around it, the knife edges of the rollers cutting off the surplus rubber strip. The wire thus insulated is fre-

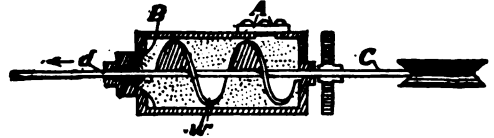

FIG. 1.—Rubber Covering Machine.

quently wrapped spirally with a tape, after which it is placed in a vulcanizing oven and vulcanized. In the seamless method the compound is placed in a plastic condition around the conduits by pressure, while passing through a die. The conductor, *c*, Fig. 1, is drawn through a metal chamber or box, *b*, which contains the plastic compound. A worm gearing, *w*, within the chamber, pushes the compound toward the opening or die, *d*, in the end of the chamber. The compound is fed into *b* at the aperture *a*. The chamber is kept at a desired temperature by a hot water or steam jacket. After leaving the chamber the insulated wire is drawn slowly along a table, through powdered talc to prevent sticking, to a drum, on which it is then taken to the vulcanizing box or receptacle, unless it is first to be taped. The taping process is somewhat analogous to that of stranding the wire. A vertical taping machine is shown in Fig. 2, in which the insulated wire *w* is seen coming through the floor to the guides *c c*, in each of which there is a slot through which tape from the small reels *r r* passes to and around the wire. The wheels on which the reels *r r* are carried revolve in opposite directions, this action laying the tapes on

the wire in reverse spirals. The wire thus taped passes to the "take up" drum T, thence to the reel D. In the case of rubber-covered wires the next proceeding is to immerse them in a water tank for 12 or 24 hours, after which they

chief ingredient in the compound that brings about these results. The compound usually enters the oven a yellowish compound and comes out a dark-blue color. This color may be varied by using different ingredients in the

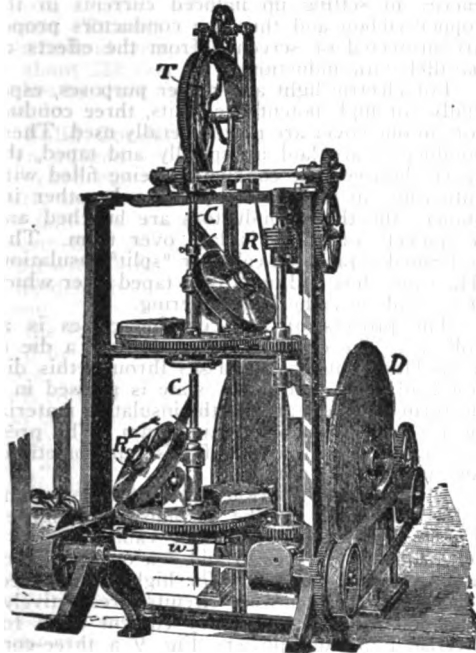

FIG. 2.—Taping Machine.

are electrically tested for defects in the insulation that may be due to air-holes, foreign substances in the insulation or any other cause.

The vulcanizing process consists in placing the insulated wire in an oven, where it is kept

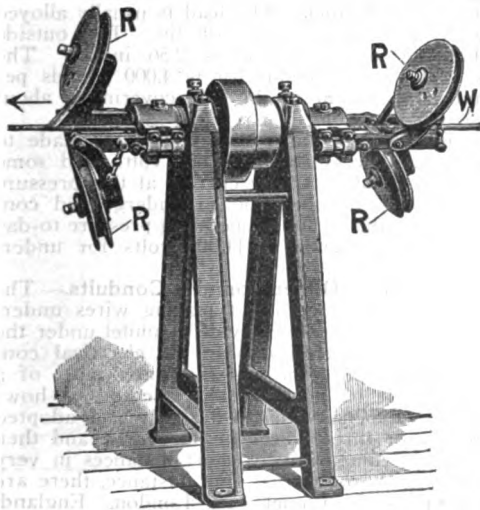

FIG. 3.—Paper Covering Machine.

at a temperature of 250° to 300° F. until the rubber compound is brought to a desired degree of hardness and tenacity, the proper time for effecting which is a matter of experiment and varies with different compounds. Sulphur is the

compound, and in some cables certain of the conductors are colored by this means to act as "markers," or distinguishing wires for testing purposes.

**Paper Insulation.**—The conductors intended

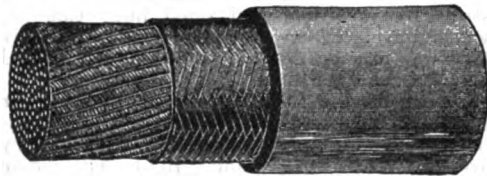

FIG. 5.—Telegraph Cable.

for telephone work are covered very loosely with two layers of dry, soft paper, laid on spirally, in practically the manner in which tape is placed over the rubber insulated wire. This type of insulation is found to be the most

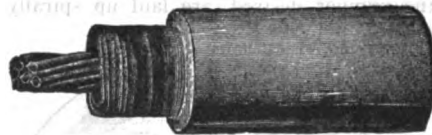

FIG. 6.—High Tension Cable.

satisfactory yet devised for telephone cables, its capacity being quite low, about .080 microfarad per mile of conductor. The insulation resistance of each conductor is about 500,000,000 ohms per mile. The wires thus insulated are twisted in

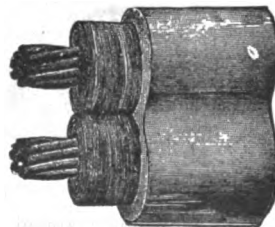

FIG. 7.—Duplex Cable, Electric Light.

pairs with a lay of about three inches, the pairs being laid up in reversed layers and built up into cables of 50, 100 and 200 pairs, after which they are lead covered as a protection against moisture. Paper cables for electric light

and power and telegraph service are made up of reversed layers of strips of manila paper to a desired thickness by means of a paper-covering machine such as is indicated in Fig. 3. In this figure *w* is the wire moving in the direction of the arrow. By suitable motive power the reels *r* carrying the paper strips are revolved in opposite directions around the wire.

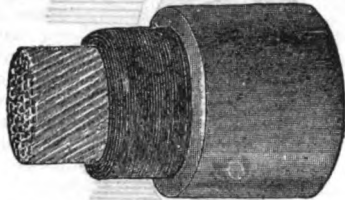

FIG. 8.—Heavy Current Cable.

When thus covered the conductor is wound on a reel and placed in an oven until all moisture is driven out of the paper. The reel, with the insulated conductor, is then immersed in a vat of boiling oil for several hours until the paper is thoroughly impregnated with the oil.

Varnished cambric insulation consists of strips of varnished and oiled linen cambric, which are placed over the conductor in as many layers as may be desired, varnish being applied between the layers.

When insulated the conductors are ready for their lead covering, if to be used as single conductors; or if to be employed in cables, they are now ready for cabling. In the latter case the number of conductors in a cable will vary with the purpose for which the cable is designed. Telephone cables for underground use may consist of as many as 400 conductors, which are first twisted in pairs and are then cabled by a cabling machine virtually similar to a stranding machine. For telegraph uses single conductors, to the number desired, are laid up spirally in

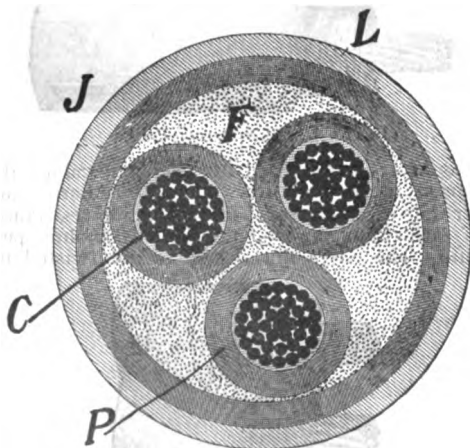

FIG. 9.—A Jacketed 7,000 to 10,000 Volt Paper Cable.

the cable. For long underground telegraph working a special type of cable has been devised to avoid the effects of static induction between conductors. This is termed a screened cable from the fact that each conductor after being insulated is covered with a thin copper ribbon laid on spirally and overlapping. The conductors thus screened are cabled in practically

the usual way. The copper ribbon over each insulated conductor is grounded by connecting it with the lead covering of the completed cable. The static lines of force set up by the telegraph currents in the conductor expend their energy in setting up induced currents in the copper ribbon and thus the conductors proper are protected or screened from the effects of parallel static induction.

For electric light and power purposes, especially for high potential circuits, three conductors in one cover are now generally used. These conductors are laid up spirally and taped, the spaces between the conductors being filled with jute rope, in the act of cabling. In other instances the three conductors are bunched and a "jacket" of paper is laid over them. This is termed a jacketed cable or "split" insulation. The cable thus laid up is then taped after which it is ready for the lead covering.

The process of lead-covering cables is as follows: The cable is drawn through a die in a die-block, and, as it passes through this die, hot lead in a semi-plastic state is pressed in a uniform thickness around the insulating material by pressure from a hydraulic ram. The pressure exerted on the end of this ram sometimes amounts to 500 tons.

Illustrations of various types of underground cables are given in the accompanying figures. Fig. 4 represents a telephone cable; Fig. 5 a telegraph cable; Figs. 6 and 7 a one-conductor and two-conductor cable for high tension electric light and power circuits, respectively; Fig. 8 a low tension, heavy current cable for electric light and power; Fig. 9 a three-conductor electric power cable for 10,000-volt circuits. In this cable each conductor *c* is made up of a strand of 37 copper wires, each .082 inch in diameter. *p* is the oil-saturated paper or varnished cambric around the conductor, .17 inch thick. *r* is the jute filling. *j* is the paper jacket, also .17 inch thick. *l* is the lead covering, .13 inch thick. The lead is usually alloyed with 2 or 3 per cent of tin. The outside diameter of this cable is 2.56 inches. The weight of each conductor is 4,000 pounds per mile; the weight of the lead covering is about 13 tons per mile.

Rubber and paper cables are now made to withstand pressures of 25,000 volts, and some miles of cable carrying current at this pressure are to-day in operation in underground conduits, but the ordinary operating pressure to-day is from say 2,000 to 11,000 volts for underground cables.

**Electric Underground Conduits.**—The most obvious method of placing wires underground would be to provide a tunnel under the streets, in which not only the electrical conductors but also the gas and water pipes of a city might be placed. This method is, however, so expensive that it has only been adopted in two or three places in the world, and then for only comparatively short distances in very crowded thoroughfares. For instance, there are several such tunnels in London, England, namely, the Holborn Street tunnel, about seven feet in height by 12 wide; the Queen Victoria Street subway and the Victoria Embankment tunnel, seven feet by nine feet. The total length of these London tunnels is about six miles and they cost approximately \$140,000 per mile, including ventilators, side passages and entrances.



In some of these tunnels, water and gas pipes, pneumatic tubes and telephone, telegraph and electric-light wires have been placed. In Paris at one time some of the sewers were utilized for the same purpose, but this plan was not greatly favored and has not been followed elsewhere. Tunnels for electrical conductors were also built in Detroit, Mich., the longest of which is about 232 feet in length. It is six feet six inches by three feet six inches in the cross-section.

**Solid Conduits.**—Another plan which has been utilized for this purpose is one in which the conductors are well insulated and laid directly in the earth; or in which the conductors are laid in notches in a tube or duct, by which means they are kept apart. The tube is then filled with an insulating compound, which, when it hardens, holds the conductors securely in position. This is termed a "solid" conduit. One of the earliest forms of solid conduit was that used by Morse, between Washington and Baltimore. This consisted of five wires insulated with cotton and placed within a lead tube which was laid directly in the earth. In different parts of Europe, in the middle of the last century and afterward, wires were laid directly in the earth without other covering than the insulating material around them, which was usually a bitumen compound or gutta-percha. Insulation laid in this way is not long lived. One of the first solid conduits used in this country for electric lighting was one in which a lead-covered cable is laid directly in a wooden trough, the cable being uncoiled directly from a cart reel, the box being then filled with an insulating compound. To protect the cable from injury, a thick plank was placed over the box.

In many European cities solid conduits are placed under the sidewalks. The cables are

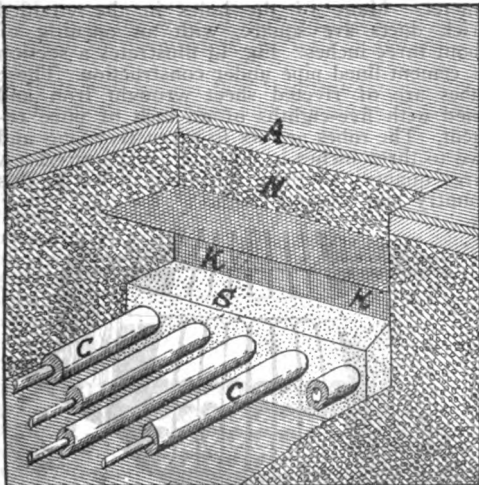

FIG. 10.—Sidewalk Conduit.

laid on a bed of sand, *s*, as indicated in Fig. 10. A galvanized iron wire netting, *k*, is placed over the sand, separating it from a bed of concrete, *n*, upon which the asphalt, *a*, of the sidewalk is laid. The object in using the wire netting is to warn workmen of the presence of the cables.

**Edison Solid or Iron Tube Conduit.**—This is the conduit adopted by Edison for the distribution of electric current by the three-wire system, for light and power in cities. It consists of an iron tube about 20 feet in length, into which the three conductors, usually copper

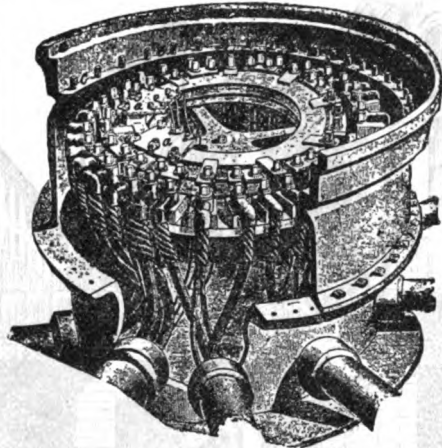

FIG. 11.—Edison Junction Box.

rods, separated from one another by hemp or jute cords, are inserted. An insulating compound is then forced, under heavy pressure, into the tube at a temperature of about 300° F. The copper rods project about two inches at each end out of the tube. The tubes are laid end to end in the earth, when the conductors in one tube are connected to those in the next by a flexible copper strand. A split iron box is then jointed and clamped over the ends of the tube and the box is then filled with an insulating compound through an opening, which is then closed by a screw plug. In this system no manholes are employed, but instead, at suitable distances, water-tight junction boxes are used, into which the conductors are led, as outlined in Fig. 11. This is really a switch-box, by means of which the current from the "feeder" conductors is distributed to the "mains" or "service" conductors. These boxes are also utilized to break up the mains into shorter sections; to open the circuits for testing and other purposes.

The disadvantage of "solid" conduits is that in case of defects in the cables there is no means of repairing them short of tearing up the streets. Neither is it convenient to add to or take from or to increase or diminish the size of conductors used in the "solid" system. These disadvantages do not exist in the case of what is termed the "drawing in" conduit system, to be described presently.

**Bare-wire Conduits.**—Still another plan utilized in some parts of Europe, and known as the "bare wire" conduit, consists of uninsulated, or bare, strips or rods of copper placed in tubes underground and held in position by insulators, or else the conduit itself is composed of an insulating material and is protected from moisture. This plan is not in extensive use.

**Drawing-in Conduit.**—The method which is now most generally employed in this country is that known as the "drawing-in" conduit. In

this system as many ducts as may be necessary are laid in a trench side by side and in layers, and manholes are built at intervals of 200, 300 or 400 feet to give access to the conduits and to afford means by which the cables may be



FIG. 12.—Standard Manhole.

drawn into the ducts. In a "drawing in" conduit system the ducts containing the "feeder" cables or cables for arc circuits are termed "trunk" ducts and are usually the lower tier or layer of ducts. The ducts carrying the distributing cables are termed "distributing ducts" and are placed at the top. So-called "hand-holes" are laid flush with the surface of the street every 40 or 50 feet to give access to the distributing ducts and cables for electric light and power service. One type of manhole is shown in Fig. 12. This is a brick manhole; others are made of concrete. The hand pump shown is used to provide fresh air where gas is prevalent in the streets. The size of the manholes and number of ducts varies with the requirements of a given locality. Some manholes are from 4 to 5 feet square; others are 12 to 15 feet deep and 6 to 8 feet wide. The number of ducts in a conduit may range from 2 to 3 ducts to 200 or 300 ducts; the larger number usually being near the power-house or the telephone or telegraph headquarters. The manholes and hand-holes are provided with double iron covers. Some of the covers are designed to make the manholes air- and water-tight; other covers are perforated to ventilate the conduits, to prevent the accumulation of gas from adjacent gas-mains, which occasionally causes explosions in the subways. The respective conductors in the

cables are joined together by twisting or by copper sleeves, in the manholes; the conductors being separated from one another by insulating material. A lead sleeve is then placed over the joints and soldered to the main cable. A hot insulating substance, as wax or paraffin, is poured into the sleeve through a small hole in the sleeve, the holes being soldered thereafter. For telegraph and telephone distribution, pipes are run from the manholes into the vaults of an adjacent building, from which point the wires are led to the subscribers' offices in the block.

The cables are drawn into the ducts by means of a rope and windlass; they are usually too heavy to be drawn by hand. Electric motors carried on wagons are also used to draw in the cables, the current for the motor being supplied by a storage battery, an adjacent power wire or a portable gas engine. In order to get the rope through the duct as it is laid, a wire is sometimes placed in the duct as it is laid. More frequently, however, the ducts are rodded by means of a stiff steel wire, or by means of screw and socket rods, similar to those used by chimney sweeps, one rod being screwed into its predecessor, which is then pushed along the duct until the distant manhole is reached, when a rope is attached to one end of the rods and drawn through the duct.

For the ducts used in the drawing-in system different material and varying lengths of pipe or tube are employed. At one time, wrought-iron pipe, 3 inches in diameter and 20 feet in length, joined together by thread couplings and laid in hydraulic cement, was extensively used in this country. About 5,000,000 feet of such pipe were laid and are still in service, but in recent years earthenware, terra-cotta or vitrified brick, stone and cement-lined pipe are mostly employed. The iron pipe and cement-lined ducts are round, about three inches in diameter. Many of the holes in the vitrified brick ducts are square, with an opening of about three inches. Fig. 13 illustrates a section of cement-lined pipe under construction. These tubes are of riveted sheet wrought iron and lined with five-eighths of an inch of pure cement. The tubes are six to seven feet long and two to three inches in diameter, as required. A large quantity of these tubes are in use in this country and Great Britain.

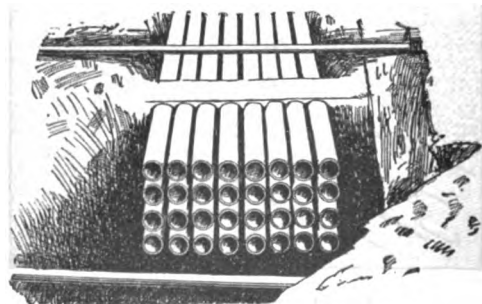

FIG. 13.—Cement-lined Conduit.

In Fig. 14 is shown a 12-duct vitrified clay conduit entering a manhole. Conduits of this type are made in blocks of two, three, four and six ducts. The four- and six-duct blocks are six feet long; the two- and three-duct blocks

are three feet in length. These blocks are laid in cement, end to end, and are held in position relative to one another by dowel pins. The walls of these blocks are five-eighths of an inch thick. A wrapping of wet muslin is laid around each joint and over the muslin cement mortar is placed. Earthenware conduits are also made in single ducts, 18 inches in length.

Wood pipe conduits consisting of wooden tubes which have been especially prepared to withstand decay are used quite largely. The single tubes are about eight feet in length and have socket joints. The tubes are laid in the trench in tiers, the lower tier resting on planking. In the various types of underground conduits mentioned and others the ducts are "broken" to add strength to the structure. Care is taken in laying these ducts to exclude cement, stones or any other obstacle that would obstruct or injure the cables in the "drawing in" process.

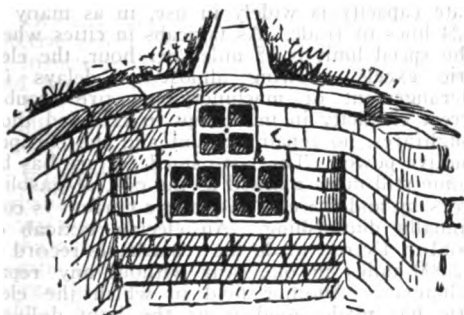

FIG. 14.—Vitrified Clay Conduit.

In the case of conduits for electric traction, the ducts are laid at the side of the tracks, underground, and wide manholes are provided at street intersections. For the "feeders" and other cables of the New York subways, conduits are laid in the wall of the structure and access is given by openings in the wall at suitable intervals.

It is well known that frequent interruptions to overhead telegraph and telephone lines are occasioned by severe wind, snow and sleet storms in this country and Europe, and in consequence the question of placing all such wires in underground conduits has frequently been raised. The great cost of such an undertaking, however, together with the fact that the speed of telephoning and telegraphing would be greatly diminished, owing to the increased electro-static capacity of the cables as compared with overhead lines, combined with other electrical obstacles, has been prohibitory of the attempt to carry out such a plan in this country on a large scale. In Great Britain an emergency underground cable system has been laid between Birmingham, London and Edinburgh. For this purpose an iron pipe containing a 76-conductor telegraph cable, with openings at certain intervals to give access to the cable, is employed. In the United States long stretches of underground telephone cables have been constructed, notably between New York, Philadelphia and Washington, D. C. The successful operation of underground telephone (metallic) circuits at such distances has been made possible by the use of the Pupin inductance coils placed at certain intervals along the

circuit and by the use of the audion telephone repeater.

WILLIAM MAVER, JR.,  
*Ex-Electrician, Consolidated Telegraph and  
Electrical Subway Co., New York.*

**ELECTRIC VEGETABLE GARDENING.** Experiments carried on at the government agricultural station at Amherst, Mass., since 1900, show that the use of electricity by the farmer is a distinct and valuable stimulus to nature and exerts a marked influence upon the germination of seeds and the growth of farm products. Scientists argue that roaming around loose in the atmosphere there is a vast fund of electrical force, which, by means of specially devised apparatus, can be attracted to the earth and distributed through the ground where the gardener has sown his seeds. The apparatus by means of which the electricity is caught and harnessed has been tested at Amherst and has proved to be a complete success. Briefly described it consists of a number of copper spikes which are elevated at the top of a 50-foot metallic pole. These spikes gather the electric fluid from the atmosphere and convey it to the foot of the pole, where it is caught by wires buried a few feet beneath the ground and distributed over as large a section as the gardener desires. Each of the poles will gather and distribute enough electricity to cover several acres of ground. With this apparatus experiments have been made which may be summarized as follows: After seeds have been subjected to the electric treatment for a period of 24 hours, it was found that over 30 per cent more seeds were germinated by the aid of electricity than in a like quantity of seeds sown in ground that lacked the electrical stimulant. As the scientists in charge of the experiments wished to make a very complete test, the electric current was applied to seeds that were allowed to stay in the ground for 48 hours. In this case it was found that 20 per cent more seeds had germinated in the electrified ground than in the soil where the seeds had been left to sprout under normal conditions, and in 72 hours this percentage had dropped to 6, thus showing that the use of the current for the purpose of stimulating germination under all the tests was a decided success.

In the various tests seeds subjected to only a temporary current of electricity have been found to show the effect for a few hours and then resume their normal growth. In one instance, to produce a constantly beneficial effect it was necessary to apply the electricity every hour to germinate growing plants or seeds.

Another interesting experiment, made in 1902, was planting in two sections of ground, the soil in both of which had been carefully selected to ensure it being exactly alike, seeds of the following vegetables: parsnip, lettuce, carrot, turnip, radish and onion. To one of the sections of ground a mild current of electricity was applied. The following day the plants in the electrified plot began to appear, the turnips sprouting first. The rapidity of growth of those planted in the electrically treated ground was far in advance of those treated in the ordinary ground. The second day plants broke through the surface in both plots, those in the electric garden showing considerably the more rapid growth; the foliage was rank and when har-

vested was nearly twice as high as that of the non-electric plot. The roots also were larger and showed a marked difference in favor of electricity. One peculiarity was that in the electric plot for every pound of roots very nearly a pound of tops was produced, while in the other case for every pound of tops there grew 1.43 pounds of root, but the difference in the total was all in favor of electricity. With reference to the other vegetables, the lettuce proved a failure in both plots. The carrots showed a marked superiority in the electric bed over those in the non-electric. The onion plants came up in both beds and grew finely for a time, then blasted and not one developed, neither electric nor non-electric.

Besides the electric treatment of the soil, experiments have been made with the electric light for stimulating the growth of plants and the general effect has been to hasten the maturity of lettuce, spinach and similar products. It has been found that the electric light has the stimulating effect of daylight upon the plants and crops thus encouraged by light from arc lamps have showed 50 to 60 per cent increase. In short it has been clearly demonstrated that by means of electricity nature can be forced to do double duty without lessening the worth of her products. See ELECTRO-CULTURE OF PLANTS.

**ELECTRIC VEHICLES.** The first vehicles operated by electric power from a storage battery appeared in 1892, but they failed to attract the attention of the general public until 1900, when the very superior performance of the electric carriage in a winter parade in the city of Cleveland, Ohio, gave them immediate prominence. The chain-drive models appeared in 1904, and continued to be the prevailing type until 1908, when the shaft-drive for the smaller vehicles was adopted. Up to that time electric vehicles were equipped with pneumatic tires. By 1912, however, solid rubber tires had been generally substituted and the battery had been enlarged to 40 cells. These two changes were the cause of a great improvement in the quality of the metal used in constructing the electric car, in order that the jars of the road might be completely absorbed and the additional weight safely carried. The result has been that the electric vehicle is the highest class of all self-propelled cars.

For city use and for the short haul, the electric possesses many advantages over steam and gasoline vehicles, the most considerable being its simplicity of construction. There are only three parts to the mechanism: the battery, the motor and the controller—no gears, no clutch and no engine as in the gasoline and steam driven cars. The motor is an engine of the rotary type, delivering a continuous torque at any desired speed up to 25 miles per hour, without the crude and bulky mechanism which controls the two or three speeds between which choice must be made with the gasoline car. Moreover the operation is noiseless. There are no nauseous odors of gasoline and burnt oil, and there is no danger from fire. The car can be started instantly and surely by simply throwing a switch and there are no jerks or jolts in either starting or stopping abruptly. No chauffeur is needed, the car practically taking care of itself and seldom needing any repairs or expert attention. The great drawbacks are

two—the weight of the storage battery which supplies the current and the limited radius of operation from a single charging of the battery, about 30 to 35 miles. In some European vehicles the radius of travel is as high as 60 miles, the weight of the battery being doubled. The usual type of battery constitutes about one-third of the weight of the car and costs about \$350. The lead battery is good for 10,000 miles and then has to be replaced with a new one. The Edison battery costs a good deal more, but is guaranteed for four years, during which a car may easily make 60,000 miles, so that while the Edison battery costs more to install it is very much more economical in the long run. The average consumption of energy is about 100 watt-hours per ton mile.

But it is not as the passenger or pleasure car that the electric vehicle demonstrates its greatest utility. This lies rather in the commercial world, where the small truck of moderate capacity is widely in use, in as many as 124 lines of trade. As taxicabs in cities where the speed limit is 15 miles per hour, the electric excels, showing almost no delays for derangement of machinery, no tire trouble, great elasticity in movement in crowded thoroughfares, no repair account and the cheapest motive power. The last-named feature has become still more marked as the cost of gasoline goes up and the cost of electric current is continually diminishing. An electric taxicab on trial in Detroit made the remarkable record of 12,000 miles in one year without any repair whatever. Another field in which the electric has made good is as the light delivery wagon, especially for the large department stores. For this use the slow-speed type of motor is in favor, running about 800 to 900 revolutions per minute, at 80 volts and 28 amperes, 4 pole series type, unsaturated. The winding is arranged for either 60 or 80 volts on larger trucks, to be used with a 60-cell Edison or 42-cell lead battery, respectively. These motors run without attention except an occasional renewing of the brushes and lubrication, for from eight months to a year. The control most generally in use is the horizontal lever, and there is a motor brake besides an efficient foot brake. The standard battery equipment is 42 cells of 15 plates each for the lead type, or 60 Edison cells of the G-7 type. For the establishment which runs its own electric plant the matter of charging the batteries becomes merely a matter of adjustment to the other work of the plant. In several cities the battery rental plan has proved popular with owners of electric vehicles. The cars can be bought without the battery and this be supplied at a stated rate per month, the battery being charged as often as exhausted. The cost of such service is not excessive, being about half the initial cost of a new battery, and there are no delays while the battery is being charged—the exhausted battery being lifted out and the fresh one put in its place.

The electric type, however, is not limited to the lighter service, as five-ton trucks are operated successfully in the transportation of coal, ice, flour, sugar, lumber, beer, etc. Fire engines to run at a speed of 25 miles per hour are in use in some cities, a particularly effective ladder truck being able to divert its motive power to

raising a 90-foot ladder, which is accomplished in 10 seconds. In several of the larger cities the Post-Office Department uses two-ton electric trucks to move mail in bulk, there being 20 of these in New York alone. For motive power for baggage and freight trucks in railroad terminals and on docks, electricity has been proved highly efficient. These little vehicles have a speed of seven to eight miles per hour when empty, and five to six miles per hour when loaded and cost to run about one cent per mile. Other adaptations of the electric vehicle are the truck crane for loading and unloading and moving materials in foundries and other manufactories of heavy products and in workshops and their yards, as road machines and road tractors, as warehouse trucks for moving goods and delivering them to gangways, as mine locomotives and in place of hand trucks in loading and unloading vessels.

One of the incidental advantages of the electric vehicle is the very considerable saving in insurance costs, both for the vehicle itself and for the premises in which it is stored.

In 1916 there were 40 concerns engaged in building electric vehicles and the number in use in the United States was estimated at above 60,000.

**ELECTRIC WAVES**, a motion or disturbance of the ether or medium in which electricity manifests itself and appears to move, of a character similar to light waves, of varying length, according to the nature of the discharge but with a velocity similar to that of light. The wave theory was early held by Clerk Maxwell, Lord Kelvin and others, but was first demonstrated by Heinrich Rudolph Hertz (q.v.), who began experimenting about 1883. He discovered that electric waves would produce a slight sparking between metals when very nearly in contact. About 1887 he exhibited a special form of condenser, which he termed a radiator, but which would now be called an oscillator, as it discharges across a spark gap with oscillations. In connection with this he employed what he termed a resonator, but which would now be styled a wave-detector. By radiating electricity at different oscillations and detecting the waves at certain harmonious distances, while demonstrating their non-appearance at intermediate points, Hertz proved the theory of wave action and that electricity travels in the same way as light, and paved the way for the later invention of wireless transmission. Hertz also reflected and refracted and polarized the waves, thoroughly demonstrating their action under the same laws as light waves. For a time the waves were referred to as Hertzian waves in honor of his contribution to science. The study of the waves was at once taken up by numerous students of electrical phenomena, and Lodge, Kelvin, Poincare and others made investigations which increased knowledge of the subject. Bose designed an instrument for producing very short electrical waves so they should be more easily studied. Later Brady of Paris devised an improved form of detector, and E. Rutherford brought out a magnetic detector. These were outclassed later by William Marconi's coherer, and that has yielded place to still more accurate detectors now used in radiography. See TELEGRAPHY, WIRELESS.

**ELECTRIC WELDING.** The heat of an electric arc may be employed in fusing or welding metals, or the heat given out in the body of metal acting as a resistance to the passage of a heavy current, without any arc or spark, may effect that result. The arc method appears to have been first employed by De Meritens in 1881. In this instance leaden pieces designed to be united in the form of storage battery plates were arranged together as an extended positive electrode, and an arc was drawn between them and a negative carbon rod manipulated by means of an operating handle. Part of the heat energy of the arc served to melt the lead and cause union of the adjacent pieces, but much the larger proportion of the energy escaped by radiation and convection. The electric arc was thus akin to a gas blowpipe as commonly used in lead-burning in the construction of tanks for the chemical industries. Following De Meritens, heating by electric arcs has been applied to the fusing and welding of metals, notably of iron and steel, by Bernardos and Olszewski, Coffin and others. When, as in the Bernardos and Olszewski method, the carbon electrode is made positive to the work, carbon is transported through the arc and is likely to enter the metal undergoing the process, which constitutes the negative pole. This addition of carbon may render iron or steel hard and unworkable, and cause cracks to be formed during the cooling of the fused mass at the joint or filling. By the employment, instead of carbon, of an electrode of the same metal as that of the work, Slaviennoff overcame this difficulty. The gradual melting of the metal electrode furnishes metal for forming joints, or for repairing or supplementing castings which are defective; such as those which are incomplete or contain blowholes. More recently the work is made the positive pole and this results in a greater proportion of the energy than formerly being expended in heating the metal undergoing the operation. Inasmuch as the conditions of energy supply for sustaining the arc are but little different from those often found in the commercial operation of arc lamps from constant potential mains, arc welding may often be practised by connections made to such mains. A choking or steadying resistance is put in series with the fusing arc in a branch from direct current lines at a potential difference of 200 volts or thereabout. With work such as that to which the Bernardos and Olszewski method has been found to be applicable, the current in the arc may vary from 150 amperes up to 500 or more. The potential across the arc itself will generally be from 100 to 150 volts. With the metal electrode used by Slaviennoff the current needed will be greater and the arc potential less than the above amounts. It appears that in certain cases the current may even surpass 4,000 amperes.

While a moderate application of these arc processes for fusing and welding iron and steel has been made, the range of operations to which they are suited is somewhat limited and their success depends largely upon the skill of the workman. He must protect not only his eyesight from the glare of the large arc, but also the surface of his body, and must avoid the irritating vapors which arise from the flame. At the same time vigorous ventilation cannot

be employed, for motion of the air tends to disturb the arc and render the work more difficult. A large proportion of the energy is radiated or carried off in the hot gases from the arc. To these energy losses must be added that due to the use of the steadying resistance for obtaining stability in the current of the arc. On the other hand the appliances needed for arc fusing or welding are simple and the source of current energy often conveniently found in existing electric circuits. One of its most recent uses has been in adding metal to rail surfaces where worn at the joints, particularly street railway rails in situ. A considerable extension of the use of arc welding has recently taken place, owing to improvements in materials and methods and to increasing demand for its use in original construction and repair work.

Werdermann, in 1874, proposed to deflect an electric arc formed between the usual carbons by a jet of air, forming thereby an electric blow-pipe. More recently Zerener has in a similar way employed an arc deflected by a magnet as a sort of blowpipe for welding iron. In addition, the curious electric heating action first published by Hoho and Lagrange has been proposed for welding metals. If a negative electrode of a direct current circuit having a potential of 100 to 150 volts is of small surface relatively to that of the positive electrode when both are immersed in a liquid bath, such as a solution of potassium or sodium carbonate, the surface of such negative electrode, when immersed, glows with light, gas bubbles arise from it, and the electrode itself heats rapidly in spite of its immersion in cold liquid. A bar of iron used as the negative electrode may thus be brought to incandescence and removed for welding, or it may even be melted under the liquid of the bath. The loss of heat in such a liquid heating process is necessarily somewhat great.

The Thomson process of electric welding, which differs radically from the arc heating operations above described, was first announced in 1886. It has since gone into extensive commercial use. No electric arc is employed, but the heat which effects the welding is solely due to the resistance of those parts of the metal pieces at the contact where they are to be welded together. This resistance is, of course, extremely low, and the delivery of sufficient energy for heating and welding is the result of the passage of relatively enormous currents. Their potential is only two or three volts, more or less. The metal pieces to be welded together are held respectively in massive clamps or vises of highly conducting metal such as copper, with a slight portion only of each piece projecting to form the joint. These projections of the pieces are brought together in firm contact, for which purpose at least one of the clamps is made movable toward and from the other, both of them being mounted on a firm support. The pieces having been adjusted to meet in correct relation for the subsequent formation of the weld uniting them, an electric current sufficient in amount to heat the meeting portions of the pieces to the temperature at which they soften and unite, is passed from clamp to clamp, thus traversing the joint and the short projecting portions of the pieces between the clamps. So heavy is the current at command that a solid bar without break spanning the space between the clamps could be heated and melted. The completion of

the weld after heating is effected by pressure exerted to force one clamp toward the other, which results in a slight upsetting or extrusion of metal at the weld called a burr. For copper a pressure of about 600 pounds per square inch of section is usual, while with iron it is 1,200 and with tool steel 1,800 pounds or more. Nearly all of the metals, even those like antimony and bismuth which are brittle and crystalline, may be united by this process, and many different metals and alloys joined one to another. In some cases as with high carbon steels, a flux such as glass of borax, is employed to facilitate union at temperatures not high enough to burn or destroy the texture of the metal. Mild steel and iron welds are usually made, as in ordinary forges, at welding heat, or that which melts or fluxes the ordinary black oxide scale upon the metal. The heavy welding currents cannot be conveyed without great loss to distances of even a few feet unless conductors of prohibitive section and cost be used. The welding clamps are in practice carried directly upon the secondary terminals of a special welding transformer. The Thomson welding transformer is a construction like a lighting transformer in which the usual secondary circuit of numerous turns is replaced by a very massive conductor constituting ordinarily only a single turn around the iron magnetic core. The primary or inducing circuit is similar to that of the ordinary transformer for alternating current and it is supplied from alternating current dynamos or lines as usual in such work. It will be seen that the secondary conductor is unique in character, being often a bar or casting of many square inches of section of copper of short length. The circuit of this single turn secondary is completed only by the meeting ends of the work pieces in the clamps. It will thus be evident that the chief resistance or opposition to the flow of the low voltage current in the single secondary turn will be at the proposed joint or weld between the clamps. Here it is then that the transformed energy is for the most part given out as heat, the section of metal which can be welded depending upon the scale of the apparatus used and the energy of the primary source which is available. The welding transformer has found convenient application in the heating of metal pieces for forging, bending, shaping, brazing or the like, in addition to welding. It has also in the Lemp process been divested of its welding clamps and applied to the local annealing of the hardened face of armor plates, so as to facilitate drilling and tapping, or cutting into desired shapes. The welds made by the Thomson process are usually butt welds, though lap welds are also made with almost equal facility. In butt welding there is of course an upset, burr, or extrusion of metal at the joint. In many cases this is not removed, and it renders the joint stronger than other adjacent sections. Oftentimes the joint is pressed or forged while still hot so as to remove the burr at the joint. In other cases the joint is finished by filing or grinding. The welding clamps are modified in form and disposition to suit the shape and size of the pieces to be held, and the pressure used to effect the weld is either manually applied by levers or is obtained from a strained spring, or again, in large work, by hydraulic means under control by suitable valves. The heating effects of the electric cur-

rent are so perfectly adjusted by regulating appliances that most of the metals formerly regarded as unweldable, yield good results with the process. Even leaden pipes, such for example, as sections of lead pipe, may be joined together with great ease. The operation of the electric welder is characterized by uniformity, rapidity, flexibility, cleanliness, neatness, accuracy and economy. It has found extensive application to repetition work; single machines making sometimes as many as 2,000 welds per day of 10 hours. It is used widely in the wagon and carriage industry for tires, axles, bands, fifth wheels, etc., and for wire bands for affixing rubber tires to wheels. Many parts of bicycles and automobiles are built up by electric welding. In the construction of tools and parts of machinery and particularly in the wire industry it plays an important part. Another important field is in the welding of wire or strip into hoops or bands for barrels, tubs, pails, etc. Machines are in operation producing electrically welded wire fencing, in which the wires which in the fence are horizontal are welded to verticals at intervals, the action somewhat resembling that of a loom. In joining pipe into continuous lengths or coils, and also in welding *in situ* street railway rails into a continuous track the electric weld possesses a special adaptability. An interesting application of the electric welder is found in the production of steel tubing by the progressive welding of a longitudinal seam. A long strip of flat sheet or *skelp* is rolled up so as to cause the lateral edges to meet. It then passes between welding rolls whereby the heating current locally traverses the meeting edges and welds them. The operation is progressive from one end of the pipe to the other as it is fed through the machine. The result is a pipe of uniform diameter with walls of even thickness, having a delicate bead along one side where the weld has been made. This bead is removed if the pipe be subsequently mandrel drawn with a reduction of its diameter. In the earlier electric welders the operations of clamping the pieces in place, applying and cutting off the electric current and exerting mechanical pressure, were usually manually controlled. Machines more or less automatic are now frequently employed. In recent types adapted for rapid repetition of work upon identical pieces, the action is entirely automatic; the machine runs continuously and its sequence of actions is definitely determined by its construction. These machines are power driven, movements being imparted for clamping the pieces as they are fed to the machine, for closing the current switch, for exerting pressure to complete the weld, for cutting off the current and for releasing the pieces from the clamps after the operation. In wire fence and chain machines the stock is itself fed automatically and the welding continued until the machine is stopped or the material exhausted. The energy required to effect electric welds naturally varies with the size of the pieces and with the material. It also depends upon the time consumed in the work, which time may be made shorter or longer even with exactly similar pieces. The following table gives the results of some tests made upon different sections of iron, mild steel, brass and copper in the form of bars. The figures are only approximate and would vary considerably if the welds had been

made in times different from those given. In general, working at a greater rapidity would lessen the total power used but require larger apparatus for the increased output required during the welding:

ENERGY USED IN ELECTRIC WELDING BY THE THOMSON PROCESS.

	Section, Sq. in.	Kilowatts in primary of welder	Time in seconds	Total kilowatt seconds
Iron and Steel.	0.5	8.5	33	280.5
	1.	16.7	45	751.5
	1.5	23.5	55	1292.5
	2.	29.	65	1885.
	2.5	34.	70	2380.
	3.	39.	78	3042.
	3.5	44.	85	3740.
	4.	50.	90	4500.
Brass.....	0.25	7.5	17	127.5
	.5	13.5	22	297.
	.75	19.	29	551.
	1.	25.	33	825.
	1.25	31.	38	1178.
	1.50	36.	42	1512.
	1.75	40.	45	1800.
2.00	44.	48	2112.	
Copper.....	.125	6.	8	48.
	.25	14.	11	154.
	.375	10.	13	247.
	.5	25.	16	400.
	.625	31.	18	558.
	.75	36.5	21	766.5
	.875	43.	22	946.
1.00	49.	23	1127.	

One of the recent and most important developments of electric welding by the Thomson process is known as "Spot" welding, and is particularly applicable to the union of sheet metal overlapped. The process is known as the Harmatta method, and is an effective substitute for riveting with the advantage of leaving the metal sheets united in spots but without rivet heads or other deformation projecting. The surfaces of the sheets may, in fact, be left smooth or with only slight indentations. To accomplish this result the two sheets to be "spot-welded" are placed one against the other and, as it were, pinched together between two heavy points or electrodes from a welding transformer secondary circuit. These electrodes being placed opposite each other press the sheets together at any desired spot, the current is then sent through them, when the sheets, where they are in contact, instantly attain the welding heat and the joint is effected in a spot with unwelded metal around it, as in riveting. The electrodes used usually have at their ends the form of truncated cones; that is, they narrow toward the work, in this way concentrating the current flow at the limited spot to be welded. On cutting off the current after a weld is made and releasing the pressure of the electrodes on the sheets, they may be moved to a new position, another spot weld effected, and so on until as many are made as desired.

Projection welding is a modification of spot welding in which the sheet metal pieces are first given small projections by stamping or otherwise. In other cases small pieces of metal are placed between the sheets at spots where the weld is to occur. Then the whole is pressed between the current carrying electrodes which may now be of such spread as to cover a num-

ber of such projections or spots at once, all being welded simultaneously. Spot welding in its various forms finds a large and rapidly extending application, particularly to sheet steel structures, such as steel car bodies, automobile bodies, metal containers, etc. It has become the general method of uniting stamped metal pieces which subsequently are to be enameled. Formerly, for example, handles were riveted to sauce pans before enameling and the rivets were plainly to be seen under the enamel. By spot electric welding the union is effected without visible change in the metal surfaces and the covering of enamel is in consequence uninterrupted and without projections.

The process is capable of further great extensions in its application to the union of overlapped sheets or plates. Riveted joints, always more or less unsightly and often disadvantageous to construction by taking up room and giving an irregular surface, can often be abolished and the spot weld substituted therefor with benefit. Besides its advantage of leaving a smooth surface, it effects a great saving of time and economizes material. As in the case of electric welding generally, the spot weld gives rise to new modes of construction of metal objects and greatly assists the substitution of pressed steel for castings or forgings.

ELIHU THOMSON.

**ELECTRIC WIRELESS TELEGRAPH.** See DEFOREST WIRELESS TELEGRAPH SYSTEM; MARCONI; TELEGRAPHY; TELEGRAPHY, WIRELESS.

**ELECTRICAL ALARM, or THERMOSTAT,** an instrument arranged to give an alarm or announcement when the temperature in its vicinity reaches a pre-determined degree. (See ELECTRIC SIGNALING, *Automatic Fire Alarm Signals*). Thermostats are also employed to automatically maintain a given temperature by opening and closing drafts, through the medium of electro-magnetically operated devices. Thermostats are operated on open or closed circuits, as desired. There are electro-pneumatic and mercurial thermostats which operate by expansion of a gas or mercury, respectively.

**ELECTRICAL DIAPASON,** a tuning fork the vibration of which is maintained by means of electro-magnetism virtually on the principle of the electric door-bell. (See ELECTRIC SIGNALING). This instrument, provided with a resonator, was employed by Helmholtz in his notable experiments on the composition of sounds.

**ELECTRICAL ENDOSMOSIS.** See OSMOSIS.

**ELECTRICAL ENGINEERING.** Electrical engineering is probably the youngest of all the professions, for it has hardly been recognized as a regular profession for more than 15 years past. As a result, the men who have reached prominence in it to-day have attained their positions from widely different courses of preliminary training; many of them are men who started life in other lines of work and afterward turned to electrical pursuits on account of the sudden growth and importance of the business. In consequence of this, all methods of preliminary education are represented

and their relative values can be estimated. The argument runs largely between two classes of men — one represented by the so-called "practical man" and the other by the theoretical electrician; the graduate of the machine shop and the graduate of the university. Both of these types have attained success, but the correct answer to the argument will probably be found in a proper combination of the two types. In the past some of the most successful electrical engineers have belonged distinctly to the class of practical men with little theoretical training, but the conditions have changed. In the early days of the profession, there was little theory or predetermination of results and work was carried on largely by guesswork or by cut and dry approximations. At the present time, however, such a state of development has been reached that exactness of result is essential to success and work based upon exact theory becomes imperative. In a stationary condition of an art a man with practical experience only may become very familiar with all the existing types of apparatus and, knowing their various applications, may qualify, to an extent, as an engineer. But the extraordinarily rapid growth of the electrical arts places electrical engineering apart from all the other engineering branches, for new discoveries and theories make radical changes from year to year in the construction and operation of electrical machinery. The engineer whose education is based only upon practical experience cannot keep up with the progress and change resulting from it, and falls behind; whereas, the man with knowledge of the theory, and a mind trained by the theoretical studies and scientific reasoning, easily grasps the theory of the change and readjusts his mind to the new without difficulty or delay. Many instances can be cited of men who have been prominent as electrical engineers, who have been dropped out of place in the course of the rapid progress which has been made, on account of a lack of theoretical foundation in their knowledge. Those who have retained their positions throughout the growth of the art have done so by persistent study along theoretical lines.

In its present state electrical engineering is the most scientific of all engineering professions. A man must be to a great extent a physicist, a chemist and a mathematician, as well as be familiar with machinery and its design, in order to be a worker in the broadest field. Many of the problems connected with other branches of engineering can be solved by common sense and by one's sense of proportion as guided by experience and by the eye. But most of the problems in electricity are invisible, so to speak, and can be understood only through their expression in the form of symbols. Probably no one will dispute to-day that the preliminary education of an electrical engineer demands a special training in those theoretical branches, mathematics, physics, chemistry and mechanics, sufficient to train his mind into accurate methods of thought and reasoning and to supply him with the actual technical information which he will need in the practice of his profession. But theory alone is not all. The human mind is such that it works with difficulty in pure theory without a series of mental pictures to fix and co-ordinate the ideas, and



the study of theory is likely to make little lasting impression unless the physical meaning of the theory is brought out by constant association with actual apparatus which demonstrates the application of the physical law. The best course of training for an electrical engineer would seem to be a broad course of education in general subjects at the preparatory school before entering college, with practical work, if possible, along lines of simple mechanics, such as carpentry, in order to train the mind into a sense of proportion and the relations of parts, which is the basis of all engineering. Next, a college course with general subjects the first year, and afterward, for the remaining years of the course, those general and theoretical subjects which have a direct bearing upon the practice of the electrical profession, such as mathematics, mechanics, physics, chemistry, theoretical electricity, and magnetism and thermodynamics. This should be supplemented by actual daily practical work with machinery operating by the principles covered by the theory studied and demonstrating all the phenomena incident to the theory. After graduation an apprentice course should be pursued in some large electrical manufacturing establishment where the commercial relations of the knowledge acquired in college can be clearly set forth. Large machines can be operated which are not available at a college and experience in the installation of large plants can be obtained, and experience gained in the designing departments where all kinds of commercial apparatus are laid out.

After a few years of this training specialization may begin along the lines selected for the life work but preferably not before. A man makes a mistake to consider himself a qualified electrical engineer after he has been graduated from college, for he is not one. His mind has been trained into a condition where he can readily absorb the principles of the electrical profession, but that is all, and the subsequent apprentice training is as important as the college course, in order to acquire the broad viewpoint from which to make the correct start in the direction in which a man is best fitted. It perhaps means a smaller income the year after graduation from college, but it means much more at the end of five years. But theory and practice are not the only elements necessary for the successful engineer. There are many qualities required in common with other professions; executive ability, business knowledge, presence of mind and ability to handle men; nerve and resourcefulness in handling machinery in times of emergency, are all necessary to the successful engineer. These elements cannot be acquired in the study of theory and practice alone, and many men who have stood high in their college courses have failed afterward in the practice of their profession because of a lack of these qualities. The study of chemistry becomes more and more important as the profession advances, for the branch of electro-chemistry is rapidly developing and is likely to become one of the largest fields in the application of electrical science. And almost above all comes a training in the English language. No man who cannot express himself clearly and concisely in writing or in conversation can hope to attain a prominent position in

his profession. The education of an electrical engineer, however, must never be considered as completed. The art advances so rapidly that constant study is necessary, even to keep up with the progress of the times. But an electrical engineer should be willing to do more than this. He should study to keep ahead of progress and do his share toward the instruction of others.

H. W. BUCK,

*Consulting Electrical Engineer, New York.*

**ELECTRICAL MANUFACTURING INDUSTRY.** The conditions as to the electrical manufacturing industries in the United States are fairly well revealed in the statistics of the Bureau of the United States Census for 1914, giving the latest authentic figures available, although these can be supplemented by later data in various ways that bring the information up to 1917 and that illustrate the swift and enormous expansion of the various electrical arts and applications. Electrical applications divide themselves into two large groups. One of these comprises the production of apparatus; and the other, many times larger, embraces the utilization of the apparatus chiefly through the agency of what are known as "public utilities," such as telegraphy, telephony, electric lighting and power supply and electric traction. One group of industries manufactures operating materials; the other group manufactures "service." In the United States, as sharply contrasted with Europe, these agencies are in the hands of private capital to an overwhelming degree, and the comparative figures of efficiency, economy and earning power are equally on the side of individual initiative and enterprise.

As to the production of electrical machinery, apparatus and supplies, the data are given herewith for 1914, when the total output for 1121 establishments was placed at a value of \$359,412,676, against which may be placed the fact that in 1916, three concerns billed a total sales of not less than \$305,000,000. The very lowest estimate for 1917 is \$600,000,000 and in view of the enhanced cost of raw material it would not be surprising if it ran in excess of that amount. These figures are revelatory of many new conditions governing the electrical arts, such as the change from steam engines to steam turbines in the generation of electrical energy, the increased use of water power, the invasion of electricity into many new fields of supply, industrial, commercial and domestic; the greater use of the electric motor; the advance of electric heating; the supersession of the arc light by the larger incandescent; the complete conquest of the incandescent lighting field by the tungsten filament lamp; the irresistible intrusion of the electric locomotive, not only into steam railway terminals but into the operation of long stretches of main line, where cheap water power is available for the generation of current.

It will be noted that dynamos have greatly increased in size, and have fallen off in value, owing to this fact. In the early days of the electric-light and power industry it was customary to employ high speed, single valve automatic steam engines for driving belted generators, as the best regulation of speed could be obtained

with engines of that type, for incandescent lighting. The steam economy of those engines was usually as low as a consumption of 40 pounds of steam per one horse power per hour. The mechanical efficiency was rarely as great as 85 per cent and the electrical efficiency of the generators was rarely 75 per cent. Corliss type engines were used for arc light circuits where the load was uniform and close regulation was not so essential. Their economy rarely exceeded 30 pounds of water per one horse power. For incandescent lighting there was an average consumption of at least 10½ pounds of coal per kilowatt hour and for arc lighting 8 pounds of coal per kilowatt hour. This compares with the present Interborough Rapid Transit 50,000 kilowatt steam turbo generators requiring as little as one and one-half pounds of coal per kilowatt hour; while it is understood that the Connell Creek station of the Detroit Edison Company has an economy even superior to that. There is a 60,000 k. v. a. triple steam turbine under construction for the Interborough system, which will have an actual capacity of 70,000 k. v. a. and is expected to have an economy of 11 pounds of steam per kilowatt hour. The increase in the size and economy of hydro-electric generating units is equally notable. The largest water turbines for electrical service are the three single runner units installed in the plant of the Tallassee Power Company on the Yadkin River, North Carolina, with a guaranteed rating of 31,000 horse power under an effective head of 180 feet, and 27,000 horse power under 165 feet at 154 r. p. m. The turbine runner weighs 20,000 pounds, is a single piece of solid bronze and is probably the largest casting of its kind ever made.

It is to be understood, however, that the manufacture and production of electrical apparatus and material is but a small part of the electrical industry as a whole. The total capitalization is placed as high as \$12,000,000,000, the gross sales and earnings are rated at above \$2,500,000,000, and the number of persons employed at more than 1,000,000. The accompanying figures were published during 1916 which while based on earlier data can be shown to be in many respects far short of the actuality. A conservative estimate for the total service and output value of electricity in 1917

made and published by the writer is as follows:

ELECTRICITY IN UNITED STATES, 1917	
Central stations.....	\$550,000,000
Electric traction.....	800,000,000
Telephony.....	425,000,000
Telegraphy.....	175,000,000
Isolated plants.....	150,000,000
Electrical manufacturing.....	600,000,000
Miscellaneous.....	125,000,000
Total.....	<u>\$2,825,000,000</u>

As to the production of apparatus alone, three concerns reported a total around \$300,000,000, and one concern reported at the end of 1917 orders on hand to the value of \$240,000,000. The increase is by no means wholly in output but must take into consideration the increase in prices as exhibited in the following table which, while applying principally to electric street railway material, is pertinent in many respects to the electrical field as a whole:

1914-16 PER CENT INCREASE IN PRICE IN TWO YEARS.

MATERIAL	Use	Approximate per cent increase in present price as compared with price of two years ago
Copper.....	Overhead system, stations and cars	220
Steel.....	Track and shops.....	300
Tin.....	Babbitt, solder, cables and overhead.....	110
Lead.....	Babbitt, solder, cables and overhead.....	200
Spelter.....	All galvanized material.....	200 to 800
Alloy metals.....	Tool steel, special work.....	125
Lumber.....	Poles, ties and shop work.....	125
Leather.....	Belting, hose, insulation.....	110 to 125
Rubber.....	Fabrics, insulation, waste.....	130 to 150
Cotton.....	Windows.....	125
Glass.....	Car work.....	135
Varnish.....	Cars, buildings and pole line.....	125
Paint.....	Insulation.....	133
Fibre.....	Rattan.....	120 to 200
Rattan.....	Seats and sweepers.....	150 to 250
Paper.....	Stationery and printed matter.....	400
Dry colors.....	General paint shop work.....	250
Linseed oil.....	Shop work, buildings and pole line.....	125
Gears and pinions.....	Motors and air-brake equipment.....	125

ESTIMATE OF ELECTRICAL INDUSTRIES OF THE UNITED STATES 1916.

	Investment or capitalization	Persons employed	Annual earnings or sales
Central electric stations.....	\$3,038,000,000	104,000	\$403,300,000
Isolated electric stations.....	1,519,300,000	52,000	201,600,000
Street and electric railways — power generation, distribution and application.....	2,681,800,000	165,000	350,500,000
Street and electric railways — railway operation.....	2,681,800,000	165,000	350,500,000
Electrified divisions of steam railroads.....	204,700,000	15,000	30,300,000
Telephone.....	1,262,760,000	237,000	329,900,000
Telegraph (land and ocean).....	231,600,000	44,000	75,300,000
Electric machinery, apparatus and supplies (including electric products of other industries).....	469,100,000	185,000	383,300,000
Electrical dealers and contractors.....	15,000,000	50,000	120,000,000
Electrical jobbers.....	25,000,000	6,000	80,000,000
	<u>\$12,129,660,000</u>	<u>1,023,000</u>	<u>\$2,324,700,000</u>

In general, most of the estimates are based upon returns of the United States Bureau of the Census. A comparison of the estimates in different sections of the industry on isolated electric stations made it apparently reasonable to assume that the totals for this branch are one-half of those for central stations.

Statistics for the electrified mileage of steam railroads are based upon the latest available figures of miles of track to which were applied the approximate averages of electric and steam railroad statistics. The very costly terminals were not taken into account.

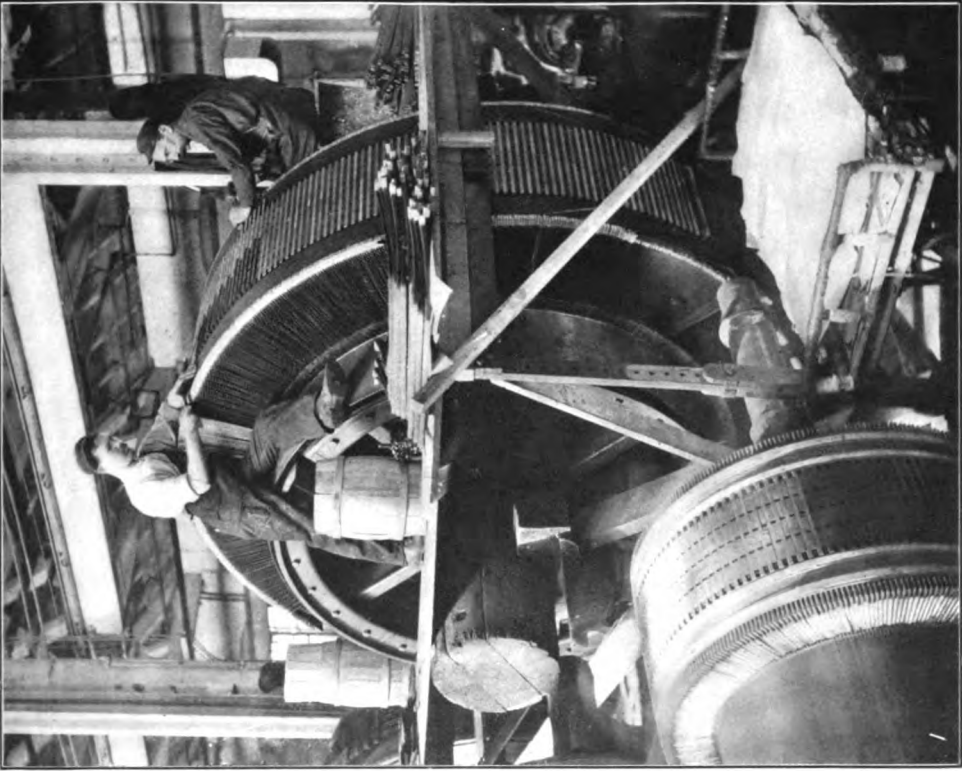

1 Winding the Armature of a Large Direct Current Generator, General Electric Works, Schenectady, N. Y.

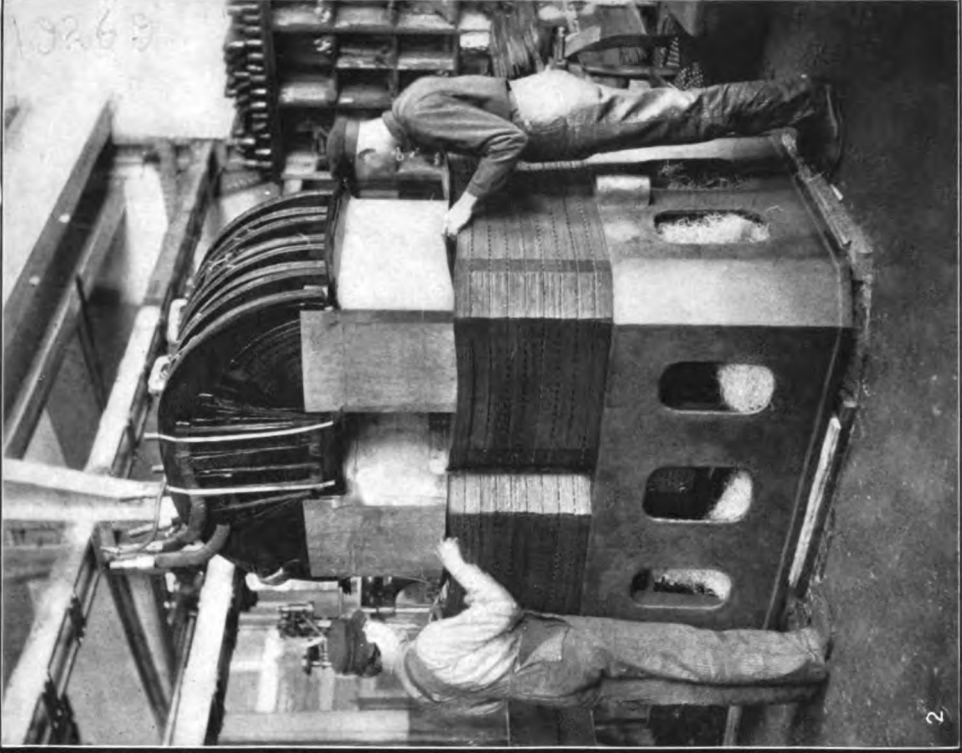

2 Building up a 1100 K. W. Transformer, Westinghouse Works, Pittsburgh, Pa.

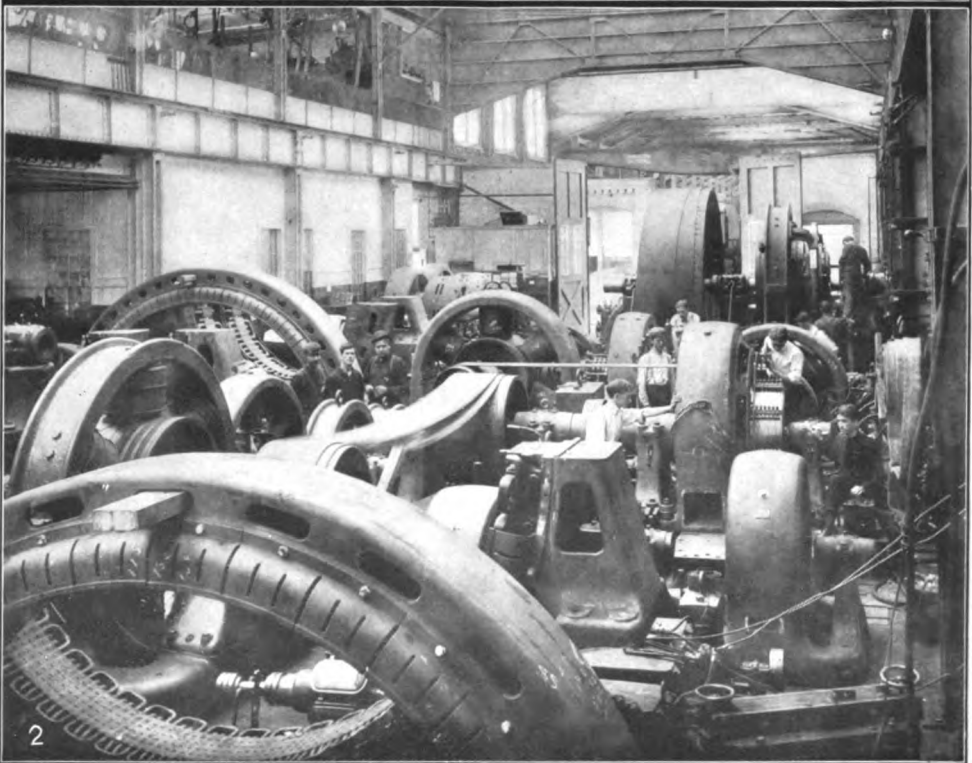

1 Operators Reading at the Testing Tables, General Electric Works, Schenectady, N. Y.  
2 Dynamo Electric Machinery Under Test, in the Testing Department, General Electric Works,  
Schenectady, N. Y.

PRODUCTION IN UNITED STATES OF ELECTRICAL MACHINERY, APPARATUS AND SUPPLIES—  
 COMPARATIVE STATISTICS: 1914 AND 1909

	1914 <sup>1</sup>	1909 <sup>1</sup>	Per cent of in- crease, <sup>2</sup> 1909-1914
Number of establishments.....	1,121	1,151	-2.6
<b>PRODUCTS</b>			
Total value.....	\$359,412,676	\$240,037,479	49.7
Dynamos, value.....	\$23,233,437	\$17,231,804	34.8
Direct current —			
Small dynamos and automobile starter-generator sets —			
Number.....	208,545	13,882	.....
Value.....	\$5,933,273	414,222	.....
All other, including generators for direct connection to steam turbines —		\$4,710,524	.....
Number.....	9,633		.....
Kilowatt capacity.....	221,221		.....
Value.....	\$2,967,465		.....
Alternating current, including generators for direct connection to steam turbines —			
Number.....	2,512	2,909	-13.6
Kilowatt capacity.....	1,188,005	991,728	19.8
Value.....	\$7,437,445	\$8,370,524	-11.1
Dynamotors, motor-generators, boosters, rotary converters, double- current generators, etc.—			
Number.....	8,393	2,291	266.3
Kilowatt capacity.....	780,009	295,079	164.3
Value.....	\$5,367,895	\$3,154,733	70.2
Parts and supplies.....	\$1,527,359	\$996,023	53.3
Transformers, value.....	\$13,120,065	\$8,801,019	49.1
Under 50 kilowatts —			
Number.....	110,177	72,776	51.4
Kilowatt capacity.....	762,707	577,408	32.1
Value.....	\$7,316,615	\$4,184,832	74.8
50 to 500 kilowatts —			
Number.....	4,857		.....
Kilowatt capacity.....	544,443		.....
Value.....	\$2,625,414	3,953	43.3
500 kilowatts and over —			
Number.....	809	1,058,021	77.9
Kilowatt capacity.....	1,337,644	\$4,616,187	25.7
Value.....	\$3,178,036		.....
Rheostats, resistances, controllers, motor-starting and speed-controlling devices, feeder-potential regulators, and reactances.....	\$9,543,224	\$2,674,963	.....
Generator-voltage regulators.....	\$245,154	(3)	.....
Rectifying apparatus (including rotating commutators, electric valves, mercury rectifiers and vibrating commutators).....	\$147,965	(4)	.....
Switchboards, panel boards and cutout cabinets for light and power.....	\$8,989,111	\$5,971,804	50.5
Motors, value.....	\$44,176,235	\$32,087,482	37.7
Direct current for industrial power and railways —			
Number.....	133,492		.....
Horse power.....	980,820		.....
Value.....	\$13,316,489	257,223	62.5
Alternating current for industrial power and railways —			
Number.....	284,500	2,410,369	19.6
Horse power.....	1,901,975	\$24,604,938	31.2
Value.....	\$18,969,660		.....
For automobiles — <sup>5</sup>			
Number.....	11,880	2,796	.....
Horse power.....	36,858	12,471	.....
Value.....	\$1,351,442	\$294,152	.....
For fans.....	\$4,835,850	\$2,450,739	97.3
For miscellaneous uses.....	\$1,190,564	\$1,942,874	-38.7
Motor parts and supplies.....	\$4,512,230	\$2,794,779	61.5
Batteries, parts and supplies, value.....	\$23,402,455	\$10,612,470	120.5
Storage —			
Value of batteries.....	\$10,615,150	\$4,243,984	150.1
Weight of plates, pounds.....	41,079,047	23,119,331	77.7
Value of parts and supplies.....	\$2,465,814	\$434,225	467.9
Primary —			
Liquid and testing —			
Number.....	306,351	344,650	-11.1
Value.....	\$802,525	\$729,513	10.1
Dry —			
Number.....	71,092,438	33,988,881	109.2
Value.....	\$8,719,164	\$4,583,082	90.2
Value of parts and supplies.....	\$799,802	\$621,666	28.7
Carbons (including furnace, lighting, brushes, battery and miscellaneous).....	\$3,602,741	\$1,934,864	86.2

PRODUCTION IN UNITED STATES OF ELECTRICAL MACHINERY, APPARATUS AND SUPPLIES—  
 COMPARATIVE STATISTICS: 1914 AND 1909—Concluded

	1914 <sup>1</sup>	1909 <sup>1</sup>	Per cent of in- crease, <sup>2</sup> 1909-1914
<b>Arc lamps:</b>			
With luminous or metallic arcs—			
Number.....	22,846		
Value.....	\$441,992		
With flame arcs—			
Number.....	4,631	123,985	—71.7
Value.....	\$153,433	\$1,706,959	—56.5
With carbon arcs—			
Number.....	7,635		
Value.....	\$146,717		
Searchlights, projectors and focusing lamps.....	\$2,081,545	\$935,874	122.4
<b>Incandescent lamps, value.....</b>			
	\$17,350,385	\$15,714,809	10.4
Tungsten—			
Number.....	74,434,059	11,738,619	534.1
Value.....	\$11,886,354	\$6,241,133	90.5
Carbon filament—			
Number.....	14,092,055	55,038,378	—74.4
Value.....	\$1,397,572	\$6,157,066	—77.3
Gem, vacuum and vapor, nitrogen, glower and tantalum.....	\$2,363,730	\$2,715,991	—13.0
Decorative and miniature lamps, X-ray bulbs, vacuum tubes, etc.....	\$1,702,729	\$600,619	183.5
Sockets, receptacles, bases, etc.....	\$5,512,609	\$4,521,729	21.9
Electric lighting fixtures <sup>3</sup> .....	\$3,383,955	\$2,200,668	53.8
<b>Telegraph apparatus, value.....</b>			
	\$2,248,375	\$1,957,432	14.9
Intelligence (key, sounder, etc.).....	\$201,956	\$197,669	2.2
Police, fire, district, etc.....	\$1,253,954	\$1,126,658	11.0
Wireless apparatus.....	\$672,575	\$448,262	50.0
Switchboards and telegraph parts and supplies.....	\$119,890	\$184,843	—35.1
<b>Telephone apparatus, value.....</b>			
	\$22,815,640	\$14,259,357	60.0
Substation instruments—			
Central battery, value.....	\$3,916,869		
Magneto, value.....	\$1,799,834		
Interior systems—			
Number.....	62,258		
Value.....	\$510,509	\$10,137,534	80.6
Central switchboards—			
Manual—			
Central battery, value.....	\$10,701,764		
Magneto, value.....	\$374,851		
Automatic.....	\$1,002,722		
Private branch exchange switchboards—			
Number.....	3,693	2,252	64.0
Value.....	\$448,203	\$369,915	21.2
Parts and supplies.....	\$4,060,888	\$3,751,908	8.2
Electric heating apparatus, value.....	\$4,034,436	\$1,954,112	106.5
Air heaters, including those for cars.....	\$352,617		
Cooking devices—			
Stoves and ranges.....	\$671,413	\$919,533	155.7
Miscellaneous cooking devices.....	\$1,327,183		
Flat irons.....	\$1,466,620	\$951,074	54.2
Welding apparatus (not including the motor-generator set).....	\$216,603	\$83,505	159.4
<b>Electric measuring instruments, value.....</b>			
	\$8,786,506	\$7,800,010	12.6
Station apparatus.....	\$1,585,500	\$1,639,202	—3.3
Testing and scientific.....	\$1,073,060	\$546,970	96.2
Meters for consumers' circuits.....	\$6,127,946	\$5,613,838	9.2
<b>Electric locomotives, mine and railway:</b>			
Number.....	900	( <sup>4</sup> )	
Value.....	\$3,720,914		
Electrical therapeutic apparatus.....	\$2,653,098	\$1,107,858	139.5
Magneto-ignition apparatus, sparks, coils, etc.....	\$22,260,847	\$6,092,343	265.4
Electric switches, signals and attachments.....	\$6,393,551	\$5,377,843	18.9
Annunciators.....	263,806	\$235,567	12.0
Electric clocks and time mechanisms.....	\$410,774	\$352,513	16.5
Insulated wire and cables.....	\$69,505,573	\$51,624,737	34.6
Electric conduits (underground and interior).....	\$4,874,709	\$5,098,264	—4.4
Lightning arresters.....	\$1,188,773	\$940,171	26.4
Fuses.....	\$1,757,430	\$1,001,719	75.4
Circuit fittings of all kinds.....	\$2,067,683	\$1,080,287	91.4
All other electrical machinery, apparatus and supplies.....	\$27,276,294	\$18,995,176	43.6
All other products, including amount received for custom work and re- pairing.....	\$23,623,244	\$17,765,645	33.0

<sup>1</sup> Includes for 1914, number and output of 91 establishments engaged primarily in other lines of industry, but which manufactured electrical machinery, apparatus and supplies valued at \$24,261,961; and for 1909, number and output of 142 similar establishments which made electrical machinery, apparatus and supplies to the value of \$18,728,916.

<sup>2</sup> A minus sign (—) denotes decrease.

<sup>3</sup> Rheostats and resistances only.

<sup>4</sup> Figures not available.

<sup>5</sup> Includes a considerable number of starting motors for gasoline automobiles, not separately reported as such.

<sup>6</sup> Not including fixtures made by establishments engaged primarily in the manufacture of gas and electric fixtures.

<sup>7</sup> Including insulated wire made in wire-drawing mills.

**Electric Light and Power Statistics.**—It is unfortunate that the authoritative statistics as to the four great groups of electrical public utilities which manufacture "service" as compiled by the government—telegraphy, telephony, electric light and power and electric street railways—do not come down to a later period than 1912. Their figures under an act of Congress are taken by the United States Bureau of the Census every five years, the last being compiled in 1912 and the next not being due until 1917, and not becoming available before the end of 1918 at the earliest. The data for 1912 are therefore presented herewith subject to the expansion up to date under the average rates of increases that are apparently revealed.

6,000,000 customers in 1916. At least 10,000,000 devices for consuming current, outside of power and light purposes, were then in circuit—flat-irons, vacuum cleaners, coffee percolators, grills, toasters, etc.—but electrical refrigeration except in bulk and especially in the production of "raw water" ice had not advanced very far. In the use of electric power some States in the South and on the Pacific Coast showed enormous gains in the period 1905-12, running up to 4,000 per cent, due in both sections to the utilization of water power, and in the South to the electrification of the cotton goods industry as a whole. As to lighting, one of the most interesting developments has been the relative supersession of arc lighting for street and commercial purposes by the incandescent lamp, al-

COMMERCIAL AND MUNICIPAL CENTRAL ELECTRIC STATIONS: 1912, 1907 and 1902

	1912	1907	1902	Per cent of increase: 1902-1912
Number of stations <sup>1</sup> .....	5,221	4,714	3,620	44.2
Commercial.....	3,659	3,462	2,805	30.4
Municipal.....	1,562	1,252	815	91.7
Total income <sup>2</sup> .....	\$302,115,599	\$175,642,338	\$85,700,605	252.5
Light, heat and power, including free service.....	\$286,980,858	\$169,614,691	\$84,186,605	240.9
All other sources.....	\$15,134,741	\$6,027,647	\$1,514,000	899.7
Total expenses, including salaries and wages <sup>3</sup> .....	\$234,419,478	\$134,196,911	\$68,081,375	244.3
Total number of persons employed.....	79,335	47,632	30,326	161.6
Total horse power.....	7,528,648	4,098,188	1,845,048	308.0
Steam engines and steam turbines—				
Number.....	7,844	8,054	6,295	24.6
Horse power.....	4,946,532	2,693,273	1,394,395	254.7
Water wheels—				
Number.....	2,933	2,481	1,390	111.0
Horse power.....	2,471,081	1,349,087	438,472	463.6
Gas and oil engines—				
Number.....	1,116	463	165	576.4
Horse power.....	111,035	55,828	12,181	811.5
Kilowatt capacity of dynamos.....	5,134,689	2,709,225	1,212,235	323.6
Output of stations, kilowatt hours.....	11,532,963,006	5,862,276,737	2,507,051,115	360.0
Estimated number of lamps wired for service:				
Arc.....	505,395	562,795	385,698	31.0
Incandescent and other varieties.....	76,507,142	41,876,332	18,194,044	320.5
Stationary motors served:				
Number.....	435,473	167,184	101,064	330.9
Horse power capacity.....	4,130,619	1,649,026	438,005	843.1

<sup>1</sup> The term "station" as here used may represent a single electric station or a number of stations operated under the same ownership.

<sup>2</sup> Exclusive of \$36,500,030 in 1912, \$20,093,302 in 1907 and \$7,703,574 in 1902, reported by street and electric railway companies as income from sale of electric current for light or power or from sale of current to other public service corporations.

<sup>3</sup> In addition to salaries and wages, includes the cost of supplies and materials used for ordinary repairs and replacement, advertising, fuel, mechanical power, electrical energy purchased, taxes, and all other expenses incident to operation and maintenance, and for 1912 charges for depreciation and charges for sinking fund.

<sup>4</sup> Includes auxiliary engines.

<sup>5</sup> Includes, for purposes of comparison, 7,082 arc and 267,997 incandescent lamps reported by the electric companies to light their own properties. Lamps used for such service were included in the total number reported in 1912.

Various items in connection with the central station electric light and power industry may here be noted. Statistics as to its income are regularly compiled by the *Electrical World* on a basis in excess of 60 per cent of the totals reported from month to month; and these show for 1916 an income of not less than \$425,000,000 from electric service. If the return from other service such as sale of electrical supplies, steam heating, refrigeration and return on investments be considered, the total 1915-16 income of the industry cannot possibly be put lower than \$450,000,000, and it is probably far in excess of that. The number of electric meters on all central station consumption circuits in 1912 was 3,617,189, coinciding very closely with the number of customers, and it is estimated on this basis and others that there were not less than

though in projection and searchlight use it has made such strides that an arc search light operating in New York has made its beam visible in Philadelphia, 90 miles away. There is also a large use of arc lights in theatrical and motion picture work. Owing to the advancing perfection of the incandescent lamp through the stages of carbon, metallized carbon, tantalum and tungsten filaments, the number of spherical candle power hours delivered for one cent has risen from 13.9 in 1885 to 71 in 1916, an increase of nearly 500 per cent in about 30 years, during which time the price of the lamp and the price of electrical energy have both decreased enormously. The rate here given is figured on operation at 1,000 hours of energy at 10 cents per kilowatt hour for current.

Among the chief advances of the period in

electrical development outside of railway work have been those in electro-chemical and electro-metallurgical development, both stimulated undoubtedly by the great war and both dependent upon the supply of cheap current. Thus one plant building in 1916 in California was to use 2,500 horse power of electrical energy generated by a hydro-electric company, with an output of 5,000 tons of caustic soda and 10,000 tons of "bleach." The electrolytic production of hydrogen and oxygen has increased enormously, so that over 300,000,000 cubic feet of hydrogen per year are thus manufactured in the United States. It is interesting to note, however, that while the electrical fixation of atmospheric nitrogen has increased enormously abroad, representing about 300,000 tons at the beginning of 1916, or a gain of over 200 per cent in three years, requiring 1,000,000 horse power, little corresponding activity has been shown in the United States up to this time of writing; although several processes of proved value are of American origin. On the contrary, the development of the electric steel furnace has been remarkable. Electrical castings command a premium where unusual durability and resistance to stress are needed. On 1 Jan. 1916, about 73 electric steel furnaces were in operation in the United States with an output of about 100,000 tons per year, but a terrific jump was made during 1916, so that the number of American furnaces was at least doubled, while their output has been estimated at 1,000,000 tons by a conservative authority. Probably the United States has now more electric furnaces than any other country.

The business of the central station has a constantly growing diversity factor. The revenue of one leading system in 1916 was derived as follows: Commercial lighting, 37 per cent; power for industrial and general purposes, 22 per cent; residence lighting, 18 per cent; power for electric railway use 23 per

cent. The item of residence lighting reveals one of the large opportunities before the central station, and includes an endless variety of apparatus and appliances, ranging from the curling iron to the electric range for cooking. In other cities than the one quoted the proportion of commercial and domestic service would average higher, although taking the country as a whole perhaps only one house or family in every five has electric service. However, very few new houses, even in remote rural districts, are built now without electrical wiring.

**Electric Railway Statistics.**—Herewith are given the latest available official statistics for the electric street railways of the United States, in this case, as in those of electric lighting, being the Census Office figures for 1912, the next compilation not being made by the government until 1917 and not available before 1918-19. The present figures serve, however, as a safe basis from which to estimate the advance in the succeeding five years in almost every respect at an average rate of increase not in excess of 8 per cent. It is a well-known fact that, as to surface traffic, street railways have been subjected to a serious competition from the automobile "jitney," but this element of loss has been largely reduced; while on the other hand it has stimulated the street railways to develop many types of new and better service, adding to the return on the investment and to the satisfaction of the public. While the surface traction lines—trolley or slot-conduit—have been working out their own salvation through this strenuous period, elevated, subway and steam railroad electrification have undergone a marvelous expansion as indicated by other statistics. The gross income of operating street railways—virtually all electric—is given for 1912 as \$520,000,000. The income of all electric service, urban, interurban and main line, is estimated for 1917 at not less than \$800,000,000.

UNITED STATES ELECTRIC RAILWAY STATISTICS.

	1912	1907	1902	PER CENT OF INCREASE <sup>1</sup>		
				1902-1912	1907-1912	1902-1907
Number of companies.....	1,260	1,236	987	27.7	1.9	25.2
Operating.....	975	945	817	19.3	3.2	15.7
Lessor.....	285	291	170	67.6	-2.1	71.2
Miles of line.....	30,437.86	25,547.19	16,645.34	82.9	19.1	53.5
Miles of single track.....	41,064.82	34,381.51	22,572.52	81.9	19.4	52.3
Rolling stock:						
Cars, number.....	94,016	83,641	66,784	40.8	12.4	25.2
Passenger.....	76,162	70,016	60,290	26.3	8.8	16.1
All other.....	17,854	13,625	6,494	174.9	31.0	109.8
Electric locomotives.....	277	117	3			
Persons employed by operating companies:						
Number.....	282,461	221,429	140,769	100.7	27.6	57.3
Salaries and wages.....	\$200,890,939	\$150,991,099	\$88,210,165	127.7	33.0	71.2
Salaried employees—						
Number.....	23,271	11,700	7,128	226.5	98.9	64.1
Salaries.....	\$26,128,786	\$12,909,466	\$7,439,716	251.2	102.4	73.5
Wage earners—						
Average number.....	4259,190	209,729	133,641	93.9	23.6	56.9
Wages.....	\$174,762,153	\$138,081,633	\$80,770,449	116.4	26.6	71.0
Power:						
Horse power, total.....	3,665,051	2,519,823	1,359,285	169.6	45.4	85.4
Steam (including turbines) and gas engines—						
Number.....	2,312	3,409	2,652	-12.8	-32.2	28.5
Horse power.....	3,193,744	2,427,862	1,310,132	143.8	31.5	85.3
Water wheels—						
Number.....	383	228	159	140.9	68.0	43.4
Horse power.....	471,307	91,961	49,153	858.9	412.5	87.1
Kilowatt capacity of dynamos.....	2,508,066	1,723,416	898,362	179.2	45.5	91.8
Output of stations, kilowatt hours.....	6,052,699,008	4,759,130,100	2,261,484,397	167.6	27.2	110.4
Current purchased, kilowatt hours.....	2,967,318,781	(e)	(e)			



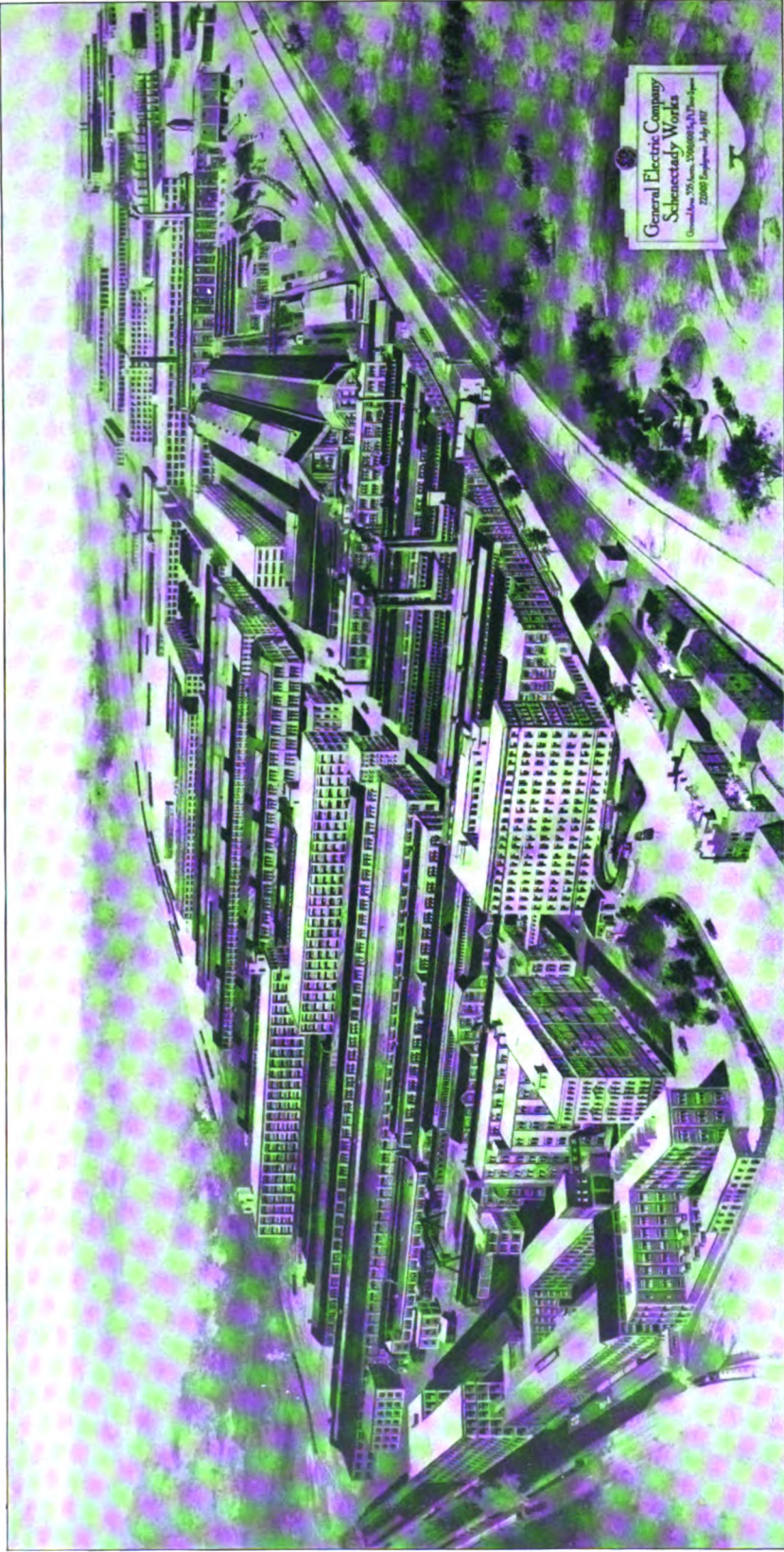

General Electric Company  
Schenectady Works  
Created from 175 acres, 1706-1914, N.Y.—Schenectady  
22,000 Employees, July, 1917

**WORKS OF GENERAL ELECTRIC COMPANY, SCHENECTADY, N. Y.**

## ELECTRIC MANUFACTURING INDUSTRY



Departments (1) No. 18; (2) No. 60, Works of General Electric Company, Schenectady, N. Y.

## UNITED STATES ELECTRIC RAILWAY STATISTICS—Concluded

	1912	1907	1902	PER CENT OF INCREASE <sup>1</sup>		
				1902-1912	1907-1912	1902-1907
<b>Traffic:</b>						
Passengers carried.....	12,135,341,716	9,533,080,766	5,836,615,296	107.9	27.3	63.3
Revenue.....	9,545,554,667	7,441,114,508	4,774,211,904	99.9	28.3	55.9
Transfer.....	2,423,918,024	1,995,658,101	1,062,403,392	128.2	21.5	87.8
Free.....	165,869,025	96,308,157	( <sup>2</sup> )		72.2	
Revenue car mileage.....	1,921,620,074	1,617,731,300	1,144,430,466	67.9	18.8	41.4
Passenger.....	1,885,870,157	1,583,831,199	1,120,101,944	68.4	19.1	41.4
Express, mail and freight.....	35,749,917	33,900,101	24,328,522	46.9	5.5	39.3
Revenue car hours <sup>3</sup> .....	190,478,140	151,338,944	65,869,342			
Passenger.....	187,590,223	148,678,052	65,403,287			
Express, mail and freight.....	2,887,917	2,660,892	466,055			
Average number of revenue pas- sengers —						
Per mile of track operated <sup>4</sup> .....	232,556	216,522	212,217	9.6	7.4	2.0
Per revenue passenger car mile.....	5.06	4.70	4.26			
Per revenue passenger car hour.....	48.38	43.06	33.28			
<b>Condensed income accounts:</b>						
Operating companies —						
Gross income <sup>5</sup> .....	\$585,930,517	\$429,744,254	\$250,504,627	133.9	36.3	71.6
Operating revenues.....	567,511,704	418,187,858	247,553,999	129.2	35.7	68.9
Transportation revenues.....	520,184,773	390,276,347	235,997,005	120.4	33.3	65.4
Non-transportation revenues.....	47,326,931	27,911,511	11,556,994	309.5	69.6	141.5
Income from other sources.....	18,418,813	11,556,396	2,950,628	524.2	59.4	291.7
Operating expenses.....	332,896,356	251,309,252	142,312,597	133.9	32.5	76.6
Net earnings (operating revenues less operating expenses).....	234,615,348	166,878,606	105,241,402	122.9	40.6	58.6
Gross income, less operating expenses.....	253,034,161	178,435,002	108,192,030	133.9	41.8	64.9
Deductions from income.....	191,123,408	138,094,716	77,595,053	146.3	38.4	78.0
Taxes.....	35,027,965	19,755,602	13,078,899	167.8	77.3	51.0
Interest on funded and floating debt and mortgages.....	98,025,338	63,740,744	38,085,911	157.4	53.8	67.4
Rent of leased lines and terminals.....	44,784,521	48,022,596	25,518,225	75.5	-6.7	88.2
Miscellaneous.....	13,285,584	6,575,774	912,018			
Net income.....	61,910,753	40,340,286	30,596,977	102.3	53.5	31.8
Dividends.....	51,650,117	26,454,732	15,882,110	225.2	95.2	66.6
Surplus.....	10,260,636	13,885,554	14,714,867	-30.3	-26.1	5.6
Lessor companies —						
Gross income <sup>6</sup> .....	35,605,367	47,913,249	26,138,899	36.2	-25.7	83.3
Rentals from operating companies.....	35,144,521	47,500,933	26,116,884	34.6	-26.0	81.9
Miscellaneous income.....	460,846	412,316	22,015		11.8	
Deductions from income.....	16,090,372	19,465,984	8,779,294	83.3	-17.3	121.7
Interest on funded and other debt.....	15,234,132	18,030,522	8,376,559	81.9	-15.5	115.2
Miscellaneous deductions.....	856,240	1,435,462	402,735	112.6	-40.4	256.4
Net income.....	19,514,995	28,447,265	17,359,605	12.4	-31.4	63.9
Dividends.....	19,342,101	28,030,542	17,157,061	12.7	-31.0	63.4
Surplus.....	172,894	416,723	202,544	-14.6	-58.5	105.7
<b>Capitalization:</b>						
Total.....	4,708,568,141	3,774,772,096	2,308,282,099	104.0	24.7	63.5
Operating companies.....	3,956,718,023	2,811,876,374	1,775,468,781	122.9	40.7	58.4
Lessor companies.....	751,850,118	962,895,722	532,813,318	41.1	-21.9	80.7
Capital stock.....	2,384,344,513	2,097,708,856	1,315,572,960	81.2	13.7	59.5
Operating companies.....	1,957,300,149	1,543,269,002	982,969,070	99.1	26.8	57.0
Lessor companies.....	427,044,364	554,439,854	332,603,890	28.4	-23.0	66.7
Funded debt.....	2,324,223,628	1,677,063,240	992,709,139	134.1	38.6	68.9
Operating companies.....	1,999,417,874	1,268,607,372	792,499,711	152.3	57.6	60.1
Lessor companies.....	324,805,754	408,455,868	200,209,428	62.2	-20.5	104.0

<sup>1</sup> A minus sign (—) denotes decrease.

<sup>2</sup> Includes track lying outside the United States, namely — 1912, 31.91 miles; 1907, 27.52 miles; and 1902, 4.20 miles. Excludes of track not operated.

<sup>3</sup> For 939 companies in 1907 and for 797 companies in 1902.

<sup>4</sup> Number employed 16 Sept. 1912.

<sup>5</sup> Figures not available.

<sup>6</sup> Represents 899 companies in 1912, 734 companies in 1907 and 390 companies in 1902.

<sup>7</sup> Exclusive of companies doing freight traffic only and in 1902 of four companies not reporting revenue passengers.

<sup>8</sup> Exclusive of six companies in 1907 and of 18 companies in 1902, which failed to furnish this information.

<sup>9</sup> Exclusive of 12 companies in 1902, which failed to furnish this information.

**Telephony and Telegraphy.**—The general statistics of the telegraph and telephone industries of the country are shown both comprehensively and comparatively in the following table. These two branches of the great modern art of the communication of intelligence are separate and distinct, yet are very closely interwoven in their physical relationships; and at various times and in various ways have been largely conducted financially as one business. The economic

reasons for such a combination are not far to seek and are recognized in the existence in most countries of a united telegraph and telephone governmental administration; whereas in the United States such a policy, under the prevailing private ownership, has been declared illegal. American telephone and telegraph systems as to apparatus used and results obtained are in general infinitely superior to anything prevailing elsewhere. A point to be noted in

## ELECTRICAL MANUFACTURING INDUSTRY

the accompanying table is the relatively disproportionate magnitude of the younger art, telephony, in all respects, particularly investment and earnings.

depots, being placed at 30,000. The annual report of the Western Union Telegraph Company for 1917 is a sufficient indication of revived prosperity now and in recent years. The report

TELEPHONE AND TELEGRAPH SYSTEMS—COMPARATIVE SUMMARY: 1912, 1907 AND 1902.

	Census	Total	Telephones <sup>1</sup>	Telegraphs <sup>2</sup>	PER CENT OF TOTAL	
					Tele-phones	Tele-graphs
Number of systems and lines.....	1912	32,261	32,233	28	99.9	0.1
	1907	22,998	22,971	27	99.9	0.1
	1902	9,161	9,136	25	99.7	0.3
Miles of single wire.....	1912	22,062,522	20,248,326	*1,814,196	91.8	8.2
	1907	14,577,325	12,999,364	1,577,961	89.2	10.8
	1902	6,218,801	4,900,451	1,318,350	78.8	21.2
Ocean cable, nautical miles.....	1912	67,676	.....	67,676	.....	100.0
	1907	46,301	.....	46,301	.....	100.0
	1902	( <sup>3</sup> )	.....	( <sup>3</sup> )	.....	.....
Employees and salaries and wages: Average number.....	1912	*220,656	183,361	37,295	83.1	16.9
	1907	172,203	144,169	28,034	83.7	16.3
	1902	106,379	78,752	27,627	74.0	26.0
Salaries and wages.....	1912	\$121,005,535	\$96,040,451	\$24,964,994	79.4	20.6
	1907	\$86,087,376	\$68,279,127	\$17,808,249	79.3	20.7
	1902	\$51,295,294	\$36,255,621	\$15,039,673	70.7	29.3
Capital stock and bonds outstanding.....	1912	\$1,213,798,950	\$991,294,115	\$222,504,835	81.7	18.3
	1907	\$1,134,909,579	\$814,616,004	\$220,293,575	79.3	29.7
	1902	\$510,977,583	\$348,031,058	\$162,946,525	68.1	31.9
Income.....	1912	\$319,844,077	\$255,081,234	\$64,762,843	79.8	20.2
	1907	\$236,045,615	\$184,461,747	\$51,583,868	78.2	21.8
	1902	\$127,755,574	\$86,825,536	\$40,930,038	68.0	32.0
Expenses.....	1912	\$262,133,861	\$203,754,909	\$58,378,952	77.7	22.3
	1907	\$182,681,918	\$140,802,305	\$41,879,613	77.1	22.9
	1902	\$96,112,805	\$65,164,771	\$30,948,034	67.8	32.2

<sup>1</sup> Includes farmer or rural lines, and in 1907 and 1912 systems reporting annual incomes of less than \$5,000; therefore, except for number of systems or lines and miles of wire, figures do not agree with those shown in other tables.

<sup>2</sup> Does not include wireless telegraph systems.

<sup>3</sup> Exclusive of 314,329 miles of wire owned and operated by railway companies.

<sup>4</sup> Not reported.

<sup>5</sup> Number employed 16 Sept. 1912.

The extent to which the condition of the times affect electrical utilities is strikingly shown in the fact that while for the period of eight months in 1917 the American (Bell) Telephone and Telegraph Company's earnings rose from \$171,608,490 to not less than \$194,337,712, the operating net income was but \$47,439,392 as compared with \$47,586,666. The whole gain of nearly \$23,000,000 was thus negated with \$150,000 more thrown in; but the gain was there all the same, and in due time the larger interest charges due to rapid increases of capital will work out to advantage. On the basis of total operating revenues of the Bell system of \$270,000,000 the year 1917 will show at 10 per cent increase an amount well in excess of \$290,000,000. For telephony as a whole, including the independent systems, a total of, say, \$425,000,000 might be set down. The physical statistics of the Bell telephone system and its growth are strikingly shown in the accompanying table.

**Telegraphy.**—As an industry the telegraph showed a remarkable recovery following the outbreak of the European War, and at the end of 1917 there were no fewer than 60,000 telegraph operators engaged at telegraph centres, local offices, brokers' offices, etc., the number of distinctively telegraph offices, including railroad

showed that the company in 1917 experienced the most prosperous year in its history. The earnings available for common dividends were equal to \$12.79 per share as against \$12.42 in the previous year. This amount was earned on almost \$100,000,000 stock. During 1917 the company paid 6¼ per cent dividends, compared with 5½ per cent in 1916. The statement for 1917, with comparison, follows:

	Gross income	Surplus income	Earned on stock
1917.....	\$78,400,000	\$12,766,000	\$12.79
1916.....	63,621,000	12,395,000	12.42
1915.....	51,171,000	10,167,000	10.19
1914.....	46,264,000	5,371,000	5.38
1913.....	45,783,000	3,234,000	3.24
1912.....	41,661,000	4,003,000	4.01
1911.....	35,478,000	5,371,000	5.38
1910.....	32,754,000	5,587,000	5.60

These significant figures are matched by those with regard to wireless telegraphy. Thus, gross earnings of the Marconi Wireless Telegraph of America have nearly doubled during the period of the war, while expenses, including taxes, were less during 1917 than in 1914. The company's net income for 1917 was \$609,430, and undivided profits and reserves on 31 Dec. 1917 amounted to \$2,150,000. The capital stock is \$10,000,000.

**Electrical Export Trade.**—The effect of

the European War has been felt generally in the export of American manufactures, but in this respect electrical goods have been a conspicuous item. The foreign demand for American electrical apparatus and supplies, even under the severe limitations imposed by lack of ships and many closed markets, has carried the strictly electrical exports from \$19,771,757 in the year ending 30 June 1915 to no less an amount than \$52,158,773 in the corresponding period 1916-17. The chief gains were in insulated wires and cables from \$1,911,850 to \$7,191,684; electrical

in use in modern power stations on land, connected to two independent induction motors mounted on each of the four propeller shafts. It is quite probable that details as to any part of this tremendous innovation in naval equipment should not be expected until the war is over. Many advantages for this method of propulsion are claimed by the designers and disputed by critics. Three battleships requiring 33,000 horse power each, of the same type, have also been provided for in naval plans; and one of these, the superdreadnought *California*, cor-

## BELL TELEPHONE SYSTEM IN THE UNITED STATES.

	December 31, 1910	December 31, 1915	December 31, 1916	Increase
Total miles of pole lines	282,877	330,602	337,289	6,687
Miles of underground conduit (length of single duct)	30,165	44,510	47,120	2,610
Miles of underground wire	5,992,303	10,536,837	11,468,525	931,688
Miles of submarine wire	24,636	36,314	41,172	4,858
Miles of aerial wire	5,625,273	7,932,394	8,340,618	408,224
Total miles of wire	11,642,212	18,505,545	19,850,315	1,344,770
Comprising toll wire	1,963,994	2,453,483	2,682,910	229,427
Comprising exchange wire	9,678,218	16,052,062	17,167,405	1,115,343
Total	11,642,212	18,505,545	19,850,315	1,344,770
Miles of phantom circuit	115,506	196,841	221,994	25,153
Total exchange circuits	2,082,960	3,174,271	3,459,069	284,798
Number of central offices	4,933	5,300	5,397	97
Number of bell stations (owned)*	3,933,056	5,968,110	6,545,490	577,380
Number of bell connected stations	1,949,663	3,183,111	3,301,702	118,591
Total stations	5,882,719	9,151,221	9,847,192	695,971
Number of employees	120,311	156,294	179,032	22,738
Number of connecting companies, lines and systems	17,845	28,306	30,358	2,052
Exchange connections daily	21,681,471	25,183,799	28,530,073	3,346,274
Toll connections daily	602,539	819,030	889,860	70,830

\* Includes private line stations.

batteries from \$967,146 to \$3,286,674; electric motors from \$2,818,743 to \$5,895,696; transformers from \$624,483 to \$1,265,459; telegraph instruments from \$76,271 to \$539,389; incandescent lamps from \$575,072 to \$2,301,407; electric meters from \$2,818,743 to \$5,895,696.

**Electrical Ships.**—A decided novelty in the field of electrical manufacture is the equipment of electrically propelled ships. The world is familiar with the use of launches driven by storage batteries and with submarine boats in which the same motive power is employed; but in the modern electrical ship propulsion is secured by means of electrical energy fed from steam turbine generators to electric motors mounted on the propeller shafts. The success of this method in the United States collier *Jupiter* would seem to be very emphatically evidenced in the provision in the Navy Bill of 1916 for four great battleships or cruisers each requiring 180,000 horse power delivered to four screw shafts turning at full speed at about 250 revolutions per minute, which yield a rate of travel through the water of 35 knots per hour. Each of the ships is to have installed four high speed turbine-driven generating units, similar to those

responding to the present direct steam-driven *Arizona*, is under construction. No other nation has yet ventured on such an experiment.

THOMAS C. MARTIN,

Secretary National Electric Light Association.

**ELECTRICAL MEASURING INSTRUMENTS.** The four fundamental electrical quantities which are being constantly measured in electric circuits are ohms, amperes, volts and watts. Another quantity of much commercial importance is watt hours.

The usual method of measuring ohms, that is, the electrical resistance of a circuit, is to use a Wheatstone Bridge, which is described elsewhere. The electrical resistance of a circuit may also be measured by what is called "fall of potential method," which consists in sending a measured current through the circuit and measuring the difference of potential between the terminals of the circuit, as illustrated in Fig. 1. When the current is measured in amperes and the difference of potential is measured in volts, the resistance is obtained by taking the ratio of the volts to the amperes. The instruments used in this measurement are

ammeters and voltmeters, which are described below.

In measuring amperes, advantage may be taken of any one of three different physical effects of the electric current: (1) The elec-

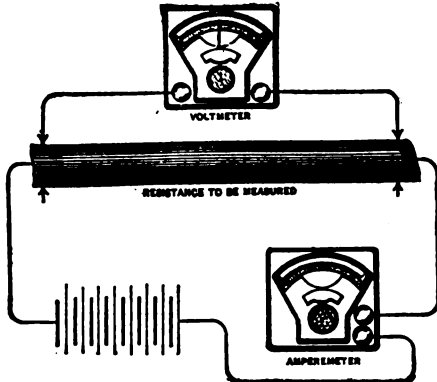

FIG. 1.—Arrangement for measuring resistance by "fall of potential."

tro-chemical effect, (2) the magnetic effect, and (3) the heating effect. Instruments which are used for measuring currents by taking advantage of the first of these phenomena are called voltmeters. When an electric current is passed through a dilute solution of sulphuric acid and water, the water is electrolyzed and the component gases, oxygen and hydrogen, are given off respectively at the two metallic terminals by means of which the current enters and leaves the water. These two terminals may be placed in the two limbs of a vertical U tube, such as the arrangement illustrated in Fig. 2, where *A* and *B* are the two ends of the U tube and *EE* are the two metallic electrodes. The arrow shows the direction of the flow of the electric current from the battery. A riser *C* is provided to maintain the supply of acidulated water as the gases collect in the upper limbs of the tube.

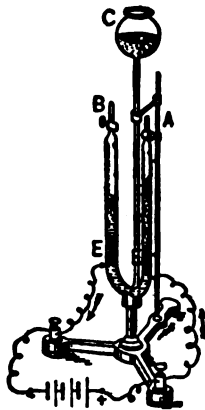

FIG. 2.—Water Voltmeter.

A water voltameter such as is here illustrated has not been found convenient or satisfactory for measuring currents, and voltmeters in which the electrolytes are the solutions of salts of metals are preferred for actual measurements. Copper plates in a solution of copper sulphate

may be used or silver terminals in a solution of nitrate of silver. Voltmeters are not now used in practice, as they are not sufficiently convenient for general use; but the silver voltmeter at one time proved to be so satisfactory for use as a standard that the International unit of current (the ampere) is defined as the current which flowing for one second through a suitable voltmeter will deposit .00118 grams of silver on the cathode.

Most of our common instruments for measuring currents depend upon the magnetic effect of the current for their indications, and each is really a modified galvanometer provided with a pointer to indicate the deflections of the needle or movable coil. Such instruments arranged for convenient, everyday measurements of electric currents are generally called amperemeters or ammeters, and they are made in numerous forms, some of them intended to be mounted upon switchboards in dynamo rooms, and others made up in more or less portable form so that they may be carried around to be used at any convenient place. The switchboard instruments—namely, those intended to be mounted on switchboards—are used in large numbers in electric lighting plants or works, where they may be seen mounted upon marble or slate boards along with switches for controlling the current. They are there used to show the dynamo attendants how much current is being generated by the plant at any moment and what proportion is furnished by each dynamo.

Portable forms of these instruments are ordinarily used in laboratories for experimental work.

According to the mechanical details entering into their construction electromagnetic ammeters may be roughly divided into three classes: (1) Those having soft iron parts which are moved by the magnetic attraction set up by the current in the coils of the instrument; (2) those having permanently magnetized parts which are acted upon by the magnetic force set up by a current in the coils of the instrument, either the coil or the magnet moving under the influence of the magnetic force; (3) those having no iron in their construction, but having two coils, one of which is moved by the magnetic force exerted between them when a current flows in both.

The moving parts of these instruments are usually mounted on pivots which are carefully finished to reduce the friction to a small value, and the instruments may be considered equivalent to galvanometers arranged with the moving parts mounted on pivots, instead of being mounted upon a delicate suspension, and each provided with a pointer arranged to play over a scale graduated to read in amperes.

If the magnetic force caused by the current in the coils of an ammeter had nothing except the friction to overcome, every current capable of moving the pointer would pull it entirely across the scale. As the instrument should be constructed so that the range of movement of the pointer is proportional to the current in the windings, a proper force must be arranged to hold the pointer back, and this may be done by properly counter-weighting the parts or using a suitable spring to oppose the magnetic force set up by the current.

Instruments of the first class may be cheaply

constructed, and formerly were commonly made by dynamo builders for use in electric light plants, but it is difficult to make them extremely accurate because the coercive force of the iron prevents it from responding equally to equal magnetic changes. For this reason instruments of the first class cannot, as a rule, be used where great accuracy is essential, but only where an accuracy within from 2 per cent to 5 per cent is sufficient. For measurements that require greater accuracy, instruments belonging to the second or third class are usually used, and these can be made so that their readings do not vary more than one-half of 1 per cent from true values when the instruments are used with proper care.

The best form of such instruments consists of a modified D'Arsonval galvanometer with a movable coil mounted upon pivots and arranged with a pointer to play over a scale, which was first successfully produced by Dr. Edward Weston. The Weston ammeters and volta-

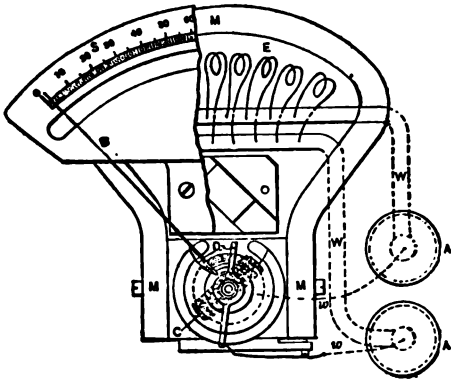

FIG. 3.—Plan of the Weston Amperemeter.

meters made of this construction may be properly said to have revolutionized the everyday measurements of amperes and volts.

Fig. 3 shows a plan of a Weston ammeter for measuring direct currents. A A represent the binding posts of the ammeter through which the current may be led to and from the instrument. W W are wires within the instrument, and E consists of a series of conducting shunts between the conductors W W. The movable coil C is connected by the wires w w with the binding posts, and through this movable coil there flows a fixed proportion of the current, which bears a ratio to the total current depending upon the electrical resistance of the shunt E and of the movable coil. The movable coil is mounted on pivots within the magnetic field of the permanent magnet M, and any motion which is caused by the magnetic effect of a current flowing through the coil is opposed by the spiral spring D. The spring and the pole pieces of the magnet M are carefully designed so that the movement of the coil shall be directly proportional to the current flowing through the coil, and the deflection is indicated on the scale S by the pointer B that is attached to the coil.

Fig. 4 shows a sectional end view of the working parts of one of these instruments. A stationary soft iron cylinder is mounted within the movable coil C for the purpose of producing radical direction and uniform density of the magnetic flux in the space between it and

the pole pieces of the magnet, within which space the conductors of the movable coil move.

Weston or similar instruments are used a great deal where accurate portable current measuring instruments are required, and instruments

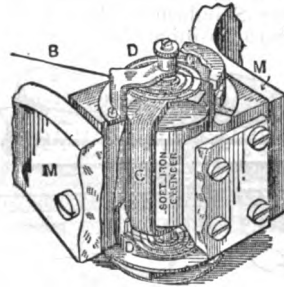

FIG. 4.—Sectional end-view of mechanism of Weston Direct Current Amperemeters and Voltmeters.

following this type are now manufactured in large numbers in this and foreign countries.

Magnetic instruments belonging to the third class are frequently called *electrodynamometers* because their indications are caused by the magnetic effect of the current in the fixed coils acting on the current in the movable coils.

Fig. 5 shows an early form of electro-dynamometer which is arranged for use as an amperemeter. This is often called the Siemens Electro-dynamometer. The coil marked F is fastened to the frame of the instrument, and the coil marked M, which stands at right angles to the first, is suspended by a heavy silk fibre or a wire so that it is free to rotate. The ends of the conductor composing the movable coil dip into little cups C C containing mercury, and these are connected with a circuit arranged so that a current can enter and leave the movable coil. The spring G is attached at one end of the movable coil, and at the other end it

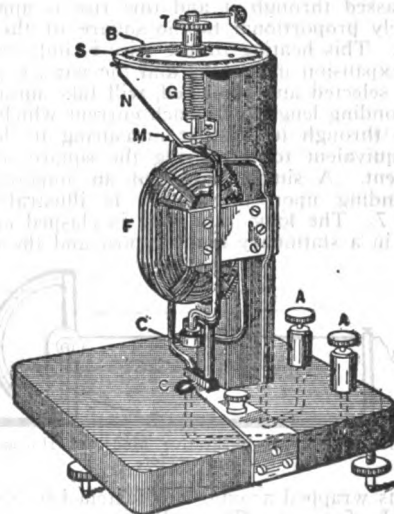

FIG. 5.—Siemens Electro-dynamometer.

is connected to a thumbscrew T called a torsion head, by means of which this spring may be twisted. When a current flows in the coils, the magnetic force tends to turn the movable coil so as to place it parallel with the fixed coil.

This force is balanced by twisting the spring by means of the thumbscrew. The amount of twist is shown by the pointer B, and it is proportional to the force exerted by the coils on each other, which in turn is proportional to the square of the current flowing in the circuit. The pointer S indicates when the movable coil is at its zero position.

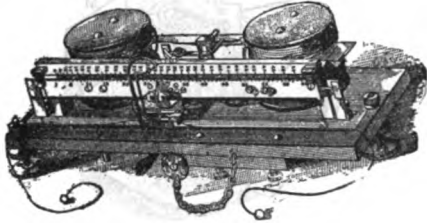

FIG. 6.— Kelvin Balance.

Very accurate and permanent standard instruments have been designed for measuring currents by this direct magnetic action, but they have not been made sufficiently portable to bring them into much use. The most important of these are the current balances of Lord Kelvin, one of which is illustrated in Fig. 6. The fixed and movable coils in these Kelvin balances are parallel to each other and horizontal. The force with which the coils tend to move with respect to each other when a current flows in them is directly balanced and weighed by means of a slider moving on a scale beam. In order to avoid any disturbing effect from the earth's magnetism, coils are placed at both ends of the balance arm.

Instruments utilizing the heating effect of the current are usually called "hot-wire" instruments. If the heated wire is carefully enclosed so that its temperature is not affected by air currents, it will rise a definite number of degrees in temperature for each current that is passed through it and this rise is approximately proportional to the square of the current. This heating of the wire is indicated by its expansion in length; and the wire, if properly selected and protected, will take up a corresponding length with each current which may flow through it, so that measuring its length is equivalent to measuring the square of the current. A simple model of an amperemeter depending upon this action is illustrated in Fig. 7. The long, thin wire is clasped at one end in a stationary binding post and the other

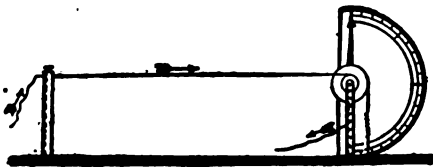

FIG. 7.— Simple Illustrative Model of Hot-wire Amperemeter.

end is wrapped around and fastened to a small wheel of metal. This wheel is supported on steel pivots, one of which is connected to another binding post. The wire is kept under a constant strain by means of a spring which is fastened to the periphery of the wheel. When the wire is heated and thereby lengthened, the wheel is turned by the contraction of the spring

and a pointer which moves over a graduated scale indicates the amount of expansion of the wire. When the wire cools again and contracts, the wheel is pulled back into its old position by the shortening of the wire.

A refined instrument of this type suitable for reasonably accurate measurements, is illustrated in Fig. 8. The extension of the measuring wire A B is indicated by a pointer moved by mechanism attached to the pulley D. The case protects the wire from air currents and the use of two stretched wires, A B and B C, through only one of which the current to be measured flows, neutralizes the effect of the general temperature of the surrounding air.

Instruments of this type are particularly useful in measuring the high frequency currents of radio telegraphy.

Instruments for measuring electrical pressures, in volts, may be made of the same forms as the ammeters utilizing the magnetic effects and the heating effects of electric currents. Such instruments are ordinarily called *voltmeters* and when they are constructed to utilize the aforementioned effects of the electric current they are really ammeters wound with coils of

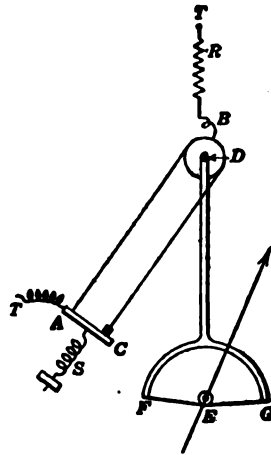

FIG. 8.

high resistance so that very little current will be wasted in the process of making the measurements of the voltage. Such an instrument really measures the very small current that is caused to flow through the resistance of its winding by the voltage to be measured. The resistance of the instrument is of constant value and the voltage is therefore directly proportional to the flow of current through the instrument. It is consequently possible to graduate the scale so that the position of the pointer indicates volts.

In most ammeters and voltmeters the scales are so divided and marked that the divisions read directly in amperes and volts. These instruments are generally called "direct reading" instruments.

Currents which rapidly alternate in direction cannot be measured by magnetic instruments like the Weston instruments having permanent magnets; but they can be measured by instruments having soft iron parts which are moved by the magnetic attraction set up by the current in the coils of the instrument, or by



instruments of the electro-dynamometer class or by hot wire instruments. In the first class of instruments, the soft iron core is always attracted by the coil in which current flows, without regard to the direction of the current and the attraction in an electro-dynamometer is also independent of the direction of the current because the current reverses at the same time in both coils. Any iron cores which are used in

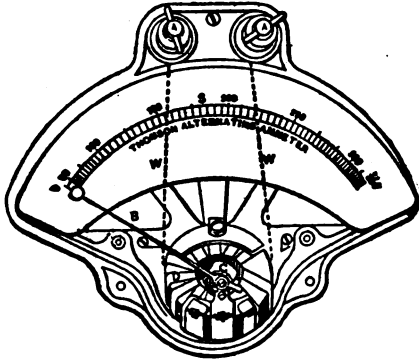

FIG. 9.—Thomson Alternating Current Amperemeter or Voltmeter, in which magnetic effect of coil acts on bit of soft iron.

instruments designed to measure these alternating currents must be built up from thin strips or fine iron wires so that induced eddy currents shall not be set up in them by the reversals of the magnetism. The working parts of an instrument which operates by the attraction of the coil D upon a thin iron strip C, are illustrated in Fig. 9, the exterior of the case having been removed so that the working parts shall be exposed.

The heating effect of currents is also independent of the direction of the current flow, so that hot wire instruments may be used for measuring alternating currents and voltages.

When very large currents are to be measured, it is often inconvenient and expensive to build an ammeter with conductors large enough to carry the entire current. In these instances an ammeter of small capacity may be shunted by a German silver wire or rod and the shunted instrument may then be calibrated and used to measure the large current. This arrangement has become quite universal in the large electric light works where very great currents are to be measured and it is not uncommon in ordinary portable instruments. Indeed, nearly all Weston self-contained ammeters, such as illustrated in Fig. 3, consist of a milli-ammeter arranged with a proper shunt E inside the case.

An entirely distinct method of measuring voltage is by means of electrometers, and when these are converted into portable form for everyday use they are called electrostatic voltmeters. They are particularly useful for measuring alternating voltages.

The electric power which is used in any part of a continuous current circuit may be determined by measuring by means of an ammeter the current flowing through the circuit and measuring by means of a voltmeter the voltage at the terminals of the circuit. In a direct current circuit the product of the number of amperes by the number of volts gives the power in watts. This product called the

volt-amperes, however, differs from the watts in an alternating current circuit when the power factor is less than unity and a summation of instantaneous values of the product must be secured. Instruments are made which in themselves perform this double measurement and multiplication so that their indications are directly proportional to power and these instruments are called *wattmeters*. The simplest form is an electro-dynamometer in which one coil is wound with many turns of fine wire exactly as though it were to be used as a voltmeter coil and the other coil is wound with a few turns of coarse wire as though it were to be used in an ammeter.

The action of such a wattmeter is best explained by an illustration. Suppose it is desired to measure the power used by an electric motor—the fine wire coil of the wattmeter is connected across the terminals of the motor and the coarse wire coil of the wattmeter is connected in series with the motor. The magnetic effect of the fine wire coil is then proportional to the voltage at the motor terminals and the magnetic effect of the coarse wire coil is proportional to the current flowing through the motor. The force exerted at any instant, to move the movable coil, is proportional to the product at that instant of the two magnetic effects and the pointer moves over the scale so as to indicate the average force, thereby indicating the watts which are transmitted through the circuit.

The connection of a wattmeter in a circuit is diagrammatically illustrated in Fig. 10, where W is the wattmeter, V V' are the terminals of the fine wire coil and C C' are the terminals of the coarse wire coil. This figure is intended to show a dynamo furnishing current to a set of incandescent lamps L L L L L, and the wattmeter is introduced in circuit for the purpose of measuring the power delivered to the lamps.

The number of alterations made in each second by the alternating currents that are ordinarily used in practice is so great that the movable coil of an electro-dynamometer acts exactly as though it were pulled around by a continuous force proportional to the average of the variable force which results from the magnetic action of the alternating current. This is true whether the instrument is arranged to be used as an alternating-current ammeter, in which instance the two coils are placed in series with each other and both are of low resistance; or the instrument is arranged to be used as a voltmeter, in which instance the two

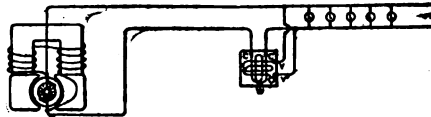

FIG. 10.—Illustration of the manner in which the coils of a Wattmeter are connected with the main circuit.

coils are connected in series with each other but both are of relatively high resistance and their resistance is re-enforced by that of a supplementary non-inductive coil of high resistance; or the instrument is arranged for use as a wattmeter, in which instance one of the coils is of low resistance and is a current coil to be connected in series with the main circuit, while the other coil is a fine wire coil of high

resistance re-enforced by a supplementary non-inductive resistance coil and is a voltage coil to be connected across the terminals of the circuit.

The wattmeter already described is called an indicating wattmeter, but it is often desirable to make a registry of the integrated consumption of energy by a customer during a given period, such as a month, and such an instrument is illustrated in Fig. 11, which is called the Thomson watt-hour meter. This is built like a little electric motor without any iron in its working parts. It is arranged with its revolving part or armature  $\lambda$  to be connected to the circuit like the fine wire coils of a wattmeter and its field magnetizing windings  $W W$  to be connected in circuit like the coarse wire coils of a wattmeter. The magnetic pull which tends at each instant to make the armature rotate is proportional to the product of the two magnetizing effects, so that the rotative effect, or torque, is proportional to the watts in the circuit. If the speed of such an armature is made proportional to the magnetic pull, it is easily seen that every revolution of the armature means a certain number of watts used for a fixed length of time. Such instruments usually have at-

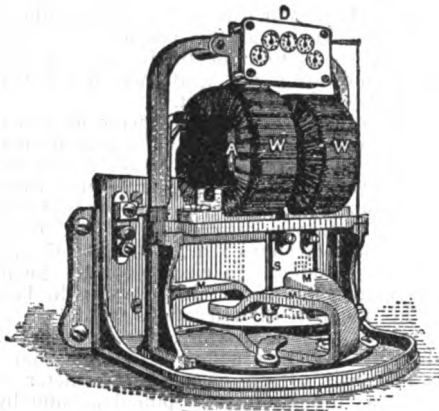

FIG. 11.— Thomson Integrating Wattmeter.

tached to the spindle of the armature a set of dials  $D$  like those of a gas meter, which record the revolutions and are so marked that the consumption of electric energy may be recorded in what are known as "watt hours." A more convenient unit for commercial instruments is the kilowatt hour, each kilowatt hour being 1,000 watt hours, and the dials of such instruments usually read in kilowatt hours.

If no external retarding force were applied to the armature of such an instrument, it would tend to run at an excessive speed for any current flowing through the apparatus and to make the instrument give an accurate record of power, a retarding force which is proportional to the speed of the armature must be applied to the spindle. This is admirably arranged by placing at the bottom of the spindle  $S$  a flat disk of aluminum  $C$ , on either side of which are placed the poles of permanent magnets  $M$ . The rotation of the disc between the magnet poles generates electric currents in it which are attracted by the magnets and retard the motion of the disc.

When the power in alternating current circuits is to be measured, it is necessary to make the self-induction of the fine wire coil of such a wattmeter practically negligible in comparison with the resistance of the coil, to prevent the readings of the instrument being affected

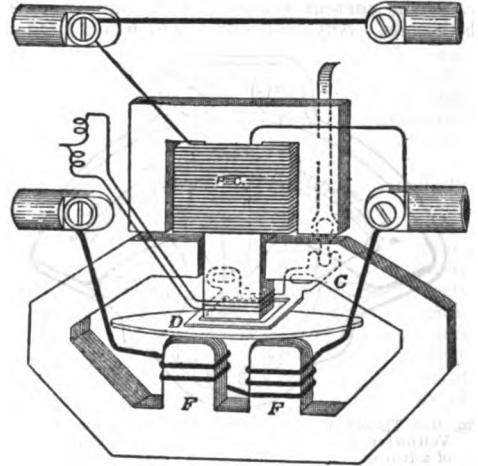
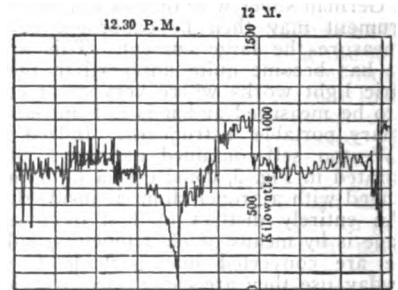

FIG. 12.

by the frequency of the alterations of the current. This is brought about by introducing a coil of high resistance and of practically no self-induction in series with the fine wire moving coil of the instrument.

Another form, called an "induction watt-hour meter" is usually used for recording the watt-hours in alternating current circuits. This instrument in its simplest form illustrated in Fig. 12, consists of coarse wire coils  $F F$  and a fine wire coil  $C$  connected to the circuit as in a wattmeter. The iron core of the fine wire coils is adjusted so that the magnetic flux lags in phase, 90 degrees behind the phase of the voltage, thus producing a magnetic field out of phase with the magnetic field produced by the coarse wire coil. These two magnetic fields



A  
FIG. 13.

act on an aluminum disc armature  $D$  and cause it to rotate like the armature of an induction motor. Permanent magnets are associated with the disc so as to cause the retardation of the rotation as in the Thomson watt-hour meter.

Sometimes a continuous record of amperes, volts or watts is desired and in that case the

pointer of an indicating instrument is tipped with a pen which plays over a moving dial or strip of paper, thus leaving a record of changes in the circuit. Instruments thus equipped are called curve-drawing instruments. Fig. 13 shows part of a record taken from a curve drawing wattmeter.

Various other instruments are used in electric circuits, such as those indicating the power factor of alternating current circuits, called power factor meters; those indicating the frequency of alternating currents, called frequency meters; and those indicating the phase and frequency relations between the currents in two alternating current circuits, called phase meters or synchrosopes. Descriptions of all such special instruments may be found in standard works on electrical engineering.

**Bibliography.**—For further information in regard to electrical measuring instruments consult Jackson, D. C. and J. P., 'Elementary Book on Electricity and Magnetism'; Laws, 'Electrical Measurements'; Swenson and Frankenhof, 'The Testing of Electro-magnetic Machinery and Other Apparatus'; Gerhardt, 'Electricity Meters: Their Construction and Management', and other treatises.

DUGALD C. JACKSON,  
Professor of Electrical Engineering, Massachusetts Institute of Technology.

**ELECTRICAL RESISTANCE.** See RESISTANCE, ELECTRICAL.

**ELECTRICAL TERMS.** The development of electrical industries and applications during the last 20 years has been so rapid and considerable as to constitute one of the salient characteristics of this era. Prior to that time a knowledge of electrical phenomena, terms and phrases was limited to a few philosophically minded persons. During that time, however, this knowledge has not only spread to a large professional and artisan class enlisting to-day more than a million persons in the United States alone; but has also extended in a considerable measure to the public at large. We can hardly read through the news of a day in the columns of a newspaper without encountering electro-technical words or phrases. The telegraph delivers its messages at every door. The telephone whispers into thousands of households in every large city. The electric light shares with the primeval flame the brightening of the evening fireside. These things speak in a language of their own and force their own terms upon our speech. The following is a list of about 100 of the electrical terms in very general use:

**AIR-BLAST TRANSFORMER.**—A transformer which is cooled when operating, by a blast of air delivered through its framework.

**ALTERNATING CURRENT.**—A current which periodically alternates, or reverses in direction.—A to-and-fro electric current; in contradistinction to a direct current. See ELECTRIC ALTERNATING CURRENT MACHINERY.

**AMMETER.**—An abbreviation of ampere-meter. An instrument which measures in amperes the electric current flowing through it.

**AMPERE, INTERNATIONAL.**—A unit of electric flow or current, theoretically derived, by electromagnetic principles, from the centimeter-gramme-second system of units. Practically defined as the current which will deposit 1.118 milligrammes of silver per second in a standard type of electrodepositing bath.

**ANODE.**—The electrode from which a current enters an electrolyte or conductor. A positive electrode.

**ARC LAMP.**—An electric lamp consisting essentially of a column of intensely heated vapor maintained between two closely opposed, or slightly separated, conducting

pencils which are usually of carbon. Much used for the illumination of streets, factories, and grounds. See ELECTRIC LIGHTING.

**ARMATURE.**—In an electromagnet, the movable element of iron or steel which is attracted to, or released from, the poles. In a dynamo, the element which is connected with the line, and which is subject to rapid cyclical changes in magnetic flux during operation.

**ASYNCHRONOUS MOTOR.**—An alternating-current motor in which the rotation is not synchronous with the rotating element of the generator supplying the driving current. See ELECTRIC ALTERNATING CURRENT MACHINERY.

**BRANCH-FUSE.**—A fuse inserted in a branch wire or circuit.

**BRUSHES OF A DYNAMO-ELECTRIC MACHINE.**—The conductors which convey current from one element to another, when there is relative motion between them. Usually, stationary conductors resting upon a rotating commutator and carrying current either to or from the same. See GENERATORS.

**BUS-BARS.**—An abbreviation of "Omnibus-bars." The main conductors in a central station, to which generators or feed-wires may be connected.

**CANOPY.**—In electric wiring of building, a metallic plate or disc attached to a wall or ceiling at an outlet to conceal the hole made where the wires protrude.

**CATHODE.**—The electrode by which a current leaves an electrolyte or conductor. A negative electrode.

**CEILING-ROSETTE.**—An insulating block fastened to a ceiling, in which electric supply wires terminate, and from which a pendant flexible cord, or other pair of conductors, descend to a lamp or fixture. Usually circular in form and fairly ornate in appearance.

**CIRCUIT-BREAKER, ELECTRIC.**—(1) A device for opening and restoring a circuit, either by hand or automatically, in the case of an overload. (2) A switch that automatically opens at overload, usually by electromagnetic mechanism.

**COHERER.**—In radio telegraphy, a receiving device consisting of an imperfect contact, the resistance of which is broken down on the passage of an electric wave, thereby enabling an electromagnetic mechanism to respond.

**COMMUTATOR.**—A device for commutating or changing the direction or path of a current. In a dynamo, the element which enables the alternating currents generated within the armature to be delivered as a unidirectional current to the external circuit.

**COMPOUND MOTOR OR GENERATOR.**—A motor or generator having both a shunt winding and a series winding on its field magnets.

**CONTINUOUS CURRENT.**—A current uniform both in strength and in direction. A steady direct current.

**CONTROLLER.**—A device for controlling an electric machine or circuit. A controlling switch.

**CONVERTER OR ROTARY CONVERTER.**—A machine which operates by means of a rotating commutator to convert alternating currents into direct currents for distribution.

**CURRENT, ELECTRIC.**—A flow or passage of electricity along an electric circuit, usually measured in amperes.

**CUT-OUT, ELECTRIC.**—(1) A device for automatically interrupting an electric circuit in which an excessive current flows, by the melting of a fuse-wire or strip carrying the current and heated thereby. (2) A device for supporting or holding an electric fuse.

**DIELECTRIC.**—An insulating material capable of being subjected to electric stress.

**DIRECT CURRENT.**—A current which, however greatly it may vary in strength, always flows in one and the same direction. A unidirectional current. See ELECTRIC DIRECT CURRENT.

**DUPLEX TELEGRAPHY.**—The method of sending messages in both directions simultaneously over one and the same telegraph wire. See TELEGRAPHY.

**EFFICIENCY OF A DYNAMO MACHINE, APPARATUS OR TRANSLATING DEVICE.**—The ratio of the power given out of the power taken in, usually measured in per cent. The ratio of output to input. A measure of the effectiveness of transformation or utilization of power by a device. Example, a motor which delivered 9 horse power, mechanically, while receiving 10 horse power, electrically, would have an efficiency of 90 per cent.

**ELECTRODE.**—The conducting terminal by which electricity finds either ingress to, or egress from, an electrolyte, a conducting mass or a dielectric. Commonly, a metal plate immersed in an electrolytic solution.

**ELECTROLYSIS.**—The chemical change accompanying the flow of electricity through electrolytes, to which class nearly all conducting liquids belong. See ELECTROLYSIS.

**ELECTROMAGNET.**—A magnet excited by an electric current and whose magnetism mainly disappears on the cessation of the exciting current.

**ELECTROMOTIVE FORCE** (abbreviated E.M.F.).—The force in an electric circuit which produces therein, or tends to produce, an electric discharge or current. Electric pressure. Voltage. Usually measured in volts.

**ENCLOSED ARC LAMP.**—An arc lamp enclosed almost airtight within a narrow glass globe, from which the oxygen in the contained air soon becomes consumed during operation, thus leaving the carbons burning in inert gas

- and greatly prolonging the duration of their serviceable life.
- FEEDER.**—In an electric distributing system, a supply conductor carrying current from a power-house to main conductors, and not itself connected to motors, lamps or translating devices.
- FIXTURE, ELECTRIC-LIGHT.**—Originally, an electric lamp-holder fixed to a wall or ceiling. Now, any electric lamp-holder whether fixed or semi-portable.
- FREQUENCY OF AN ALTERNATING CURRENT.**—The number of complete cycles, or to-and-fro motions, effected by the current in one second of time.
- GALVANOMETER.**—An instrument for measuring the strength of an electric current. Usually a sensitive instrument which measures the strength of a very feeble current, as distinguished from an ammeter.
- GALVANOSCOPE.**—An instrument for detecting the passage of an electric current.
- GENERATOR, ELECTRIC.**—A machine which is capable of generating an electric current. Usually a dynamo-electric generator or dynamo.
- GROUND.**—(1) The earth, considered as an electric conductor. (2) A return circuit provided through the ground. (3) A fault or leak of electricity to the earth through a defect in the insulation of a conductor. See **ELECTRIC CONDENSER**.
- HIGH-POTENTIAL SYSTEM.**—In electric distribution, a system of conductors, generators and translating devices in which the pressure or voltages is relatively high. Specifically, an electric distributing system, which, according to fire insurance rules, has within it a pressure of over 550 volts and less than 3,500 volts.
- INCANDESCENT LAMP.**—An electric lamp consisting essentially of a glowing filamentary conductor maintained at an incandescent temperature by a traversing electric current.
- INDUCTION MOTOR.**—An asynchronous alternating-current motor in which the currents flowing in the winding of the secondary member are induced electromagnetically by the currents flowing in the primary member. See **ELECTRIC ALTERNATING CURRENT MACHINERY**; **ELECTRIC MOTORS**; **GENERATORS**.
- INSULATION, ELECTRIC.**—The property of nonconduction. Particularly the property possessed by a conductor when it is kept out of contact with, or out of likelihood of discharge to, the ground or neighboring conductors.
- INTERIOR CONDUIT.**—A tube or raceway placed in the interior walls, floors or ceilings of a building, to guide, hold and protect the wires or conductors supplying the building.
- JOULE, INTERNATIONAL.**—A unit of work theoretically derived from the centimeter-gramme-second system of units and equal to 10,000,000 ergs. Approximately equal to 0.74 foot-pound.
- KILOWATT HOUR.**—A unit of work generally used in the sale of electric energy. One thousand watt hours, 3,600,000 joules; approximately 2,700,000 foot-pounds or 1,200 long-foot-tons, or 1.34 horse-power hours. The work done by one ampere under a pressure of 1,000 volts in one hour.
- LIGHTNING ARRESTER.**—A device connected to an electric circuit or system for the purpose of protecting the system from damage by atmospheric electricity. Commonly a device connected to an aerial line either on a pole or near the point of entrance to a station, and offering a separate conducting path to ground along which lightning discharges may be deflected. See **GENERATORS**; **LIGHTNING ARRESTER**.
- LOAD.**—The output of, or demand upon a machine, usually measured either in terms of current delivered or of power delivered. A load may be light, heavy, normal, full, half, excessive, etc., according to the output of the machine at the time considered.
- LOW POTENTIAL SYSTEM.**—In electric distribution, a system of conductors, generators and translating devices in which the pressure or voltage is relatively low. Specifically, an electric distributing system, which, according to fire insurance rules, has within it a pressure less than 550 volts and more than 10 volts.
- MAGNETIC FIELD.**—Any region in space permeated by magnetism. A magnetized space. Commonly a magnetized air-space.
- MAGNETIC FLUX.**—The magnetism or magnetic influence which permeates a magnetic field. This influence possesses at any point both intensity and direction. By reference to these properties, the magnetic lines of influence may be conceived of as stream lines or lines of magnetic flow or flux, and may be expressed in terms of a unit named the *Maxwell*.
- MAINS.**—In an electric distributing system, the street-supply conductors, to which the house-service wires are connected. The main conductors intended for connecting to lamps, motors or devices at any point along their route. In house-wiring, the principal supply wires, as distinguished from submains, taps or branches.
- MEGOMH.**—A million ohms; derived from "Ohm" and the prefix "mega" signifying by convention one million, and literally, in ancient or modern Greek, "great."
- MICROPHONE.**—An apparatus capable of having its resistance affected by very feeble sounds and, therefore, of enabling such sounds to be heard with the aid of a telephone in the circuit. In telephony, the carbon transmitter connected with the diaphragm against which the speaker's voice is directed.
- MORSE CODE.**—The code of dots and dashes forming the alphabet of the Morse system. See **TELEGRAPHY**.
- MORSE SYSTEM OF TELEGRAPHY.**—The system of telegraphy originally devised by Samuel Morse, in which an electromagnet placed in the telegraph line circuit responds to impulses of the sender's key, and actuates an armature in such a manner as to give either audible or legible signals to the receiving operator. See **TELEGRAPHY**.
- MOTOR, ELECTRIC.**—A machine for transforming electric power into utilizable mechanical power. Motors almost invariably operate on electromagnetic principles. See **ELECTRIC ALTERNATING CURRENT MACHINERY**; **ELECTRIC MOTOR**; **GENERATORS**.
- MOTOR-STARTER.**—An automatically operating device for starting a motor from rest with a proper rate of acceleration by the simple act of closing a switch.
- MULTIPOLAR DYNAMO.**—A dynamo having more than one pair of magnetic poles in its field frame.
- OHM, INTERNATIONAL.**—A unit of electric resistance, theoretically derived, by electromagnetic principles, from the centimeter-gramme-second system of units. Practically defined as the resistance offered by a uniform column of pure mercury 106.3 centimeters long and weighing 14.4521 grammes, at the temperature of melting ice.
- OIL-COOLED TRANSFORMER.**—A transformer which is cooled, when operating, by a flow of oil through its framework.
- OSCILLATING CURRENT.**—An alternating current or discharge, gradually or rapidly decreasing to zero intensity.
- OVERLOAD.**—An excessive load or duty imposed upon a machine or device. An abnormal or an extra load.
- PHASE.**—The fractional development of an alternating electric wave with reference to a cyclic condition such as the zero point in the positive direction. Usually measured in degrees of 360 to the complete cycle.
- POLYPHASE SYSTEM.**—An alternating-current distributing system employing a plurality of alternating currents definitely differing in phase. See **ELECTRIC ALTERNATING CURRENT MACHINERY**.
- POWER-FACTOR.**—The ratio of the active power, in watts, absorbed by a circuit or conductor carrying an alternating current, to the apparent power consumed, in volt amperes.
- PRIMARY VOLTAIC CELL.**—A voltaic cell which derives its energy from its chemical constituents and which consumes or converts those constituents irreversibly during action; as distinguished from a secondary cell which, after discharging, may be recharged by the action of an electrical charging current.
- QUADRUPLEX TELEGRAPHY.**—The method of sending four messages simultaneously over one and the same telegraph wire, two in one direction and two in the opposite direction. See **TELEGRAPHY**.
- RAIL-BONDS.**—The conducting straps or bridges applied between contiguous ends of rails in an electric railway in order to improve their electric conducting power.
- RELAY.**—An apparatus, usually electromagnetic, which controls and operates a local circuit by opening or closing the same. In telegraphy, a sensitive electromagnet inserted in the telegraph line which, by the movement of its armature, operates a sounder, or other translating device, in a local circuit, with a vigor that the line current could not directly exert. See **GENERATORS**; **TELEGRAPHY**.
- RESISTANCE, ELECTRIC.**—The property of conducting substances by virtue of which they obstruct or oppose the passage of an electric current. Usually measured in ohms. The opposite or inverse of conductance.
- RHEOSTAT.**—An adjustable electric resistance.
- ROTOR.**—The rotating element of a machine as distinguished from the stationary element.
- SERIES MOTOR OR GENERATOR.**—A motor or generator whose field-magnet winding is connected in series with, or in succession to, its armature. See **GENERATOR**.
- SERIES-PARALLEL CONTROLLER.**—A device on the platform of an electric street car, operated by a handle, through the aid of which the motorman can with his left hand connect the motors under the car either in series or in parallel, so as to vary the speed of the car.
- SHADE.**—In electric incandescent lighting, the ornamental bell or cover, usually of glass, secured over a lamp in order to scatter or reflect the light and produce either a better distribution of light or a more pleasing effect upon the eye of the observer.
- SHUNT.**—An electrical by-pass. A conductor which is applied to the terminals of an apparatus or branch in order to divert a part of the current from that branch.
- SHUNT MOTOR OR GENERATOR.**—A motor or generator whose field-magnet winding is connected in shunt to, or in parallel with, its armature. See **GENERATOR**.
- SHORT-CIRCUIT.**—A cross between active electric conductors whereby an excessively strong current is produced. Usually a metallic bridging between two or more supply

- wires, whereby a violent overload of current results, capable, in extreme cases, of producing violent arcing, burning, or disruptive local effects.
- SINGLEPHASE SYSTEM.**—An alternating-current distributing system employing a single alternating current supplied by the generator, as distinguished from a polyphase system.
- SOCKET OF INCANDESCENT LAMP.**—The holder into which an incandescent lamp screws or attaches and which contains the ends of electric supply wires, for supplying current to the lamp.
- STATOR.**—The stationary element of a machine, as distinguished from the rotating element.
- STORAGE BATTERY.**—A grouping of secondary or storage cells. See **ELECTRIC STORAGE BATTERY.**
- STORAGE CELL.**—A voltaic cell which receives its electrochemical energy from the electrolytic action of a charging current. A voltaic cell which is alternately charged and discharged.
- SUB-STATION.**—In an electrical distributing system, a local or auxiliary power-house for facilitating the operation or control of the system. A station which is subsidiary to a principal station or power-house.
- SWITCH, ELECTRIC.**—Any device for opening, closing or modifying an electric circuit. Usually a hand-operated device for opening and closing a circuit.
- SWITCHBOARD.**—An assemblage of switches, controlling or indicating devices mounted upon a frame for the purpose of convenient control or inspection of an electric path, circuit or system of circuits. Originally, a board with switches mounted on it; now typically, a metal frame holding vertical slabs of slate or marble, with switches, controlling handles, and indicating or recording instruments mounted thereon, in an electric central station or distributing centre. In telephony, a frame holding the switches and other devices by which connections are made between subscribers.
- SYNCHRONOUS MOTOR.**—An alternating-current motor in which the rotation occurs in synchronism with the rotating element of the generator supplying the driving current. See **ELECTRIC ALTERNATING CURRENT MACHINERY.**
- THIRD RAIL.**—In an electric railway system, a supply conductor running parallel to the track and consisting of a steel rail electrically continuous and supported on insulators, for carrying current to the car-motors. See **THIRD-RAIL SYSTEM.**
- THREE-PHASE SYSTEM.**—An alternating-current system employing three alternating currents, of equal strength, differing in phase by  $120^\circ$ , or one-third of a cycle.
- THREE-WIRE SYSTEM.**—In electric distribution, the system which provides three main conductors, the middle one of which is neutral, or midway in potential between the other two.
- TORQUE.**—The twisting effort, rotating effort or mechanical couple exerted by a motor at a shaft. Often measured in pounds' weight at one foot radius.
- TRANSFORMER.**—A device for changing the pressure or current of electric energy supply. Usually, a stationary electromagnetic device consisting of a laminated iron core and two insulated windings, a primary and a secondary. The device transfers electric power of alternating currents from the primary to the secondary circuit, and changes the voltage in the ratio of the number of turns in the two windings.
- TRANSFORMER, STEP-DOWN.**—A transformer which locally lowers the electric pressure; i.e., which has a lesser number of turns in the secondary than in the primary winding and thereby produces a lower voltage in the secondary circuit than in the primary.
- TRANSFORMER, STEP-UP.**—A transformer which locally raises the electric pressure; i.e., which has a greater number of turns in the secondary than in the primary winding and thereby produces a higher voltage in the secondary circuit than in the primary.
- TRANSLATING DEVICE.**—Any device actuated electrically which receives electrical energy and translates it into energy of some other type, such as mechanical energy.
- TROLLEY-WHEEL.**—The metallic wheel which is carried at the upper end of a street-car trolley pole, and which is pressed upward against the trolley wire, in order to maintain running contact therewith.
- TURBO-ALTERNATOR.**—A machine consisting of an alternating-current generator mounted upon the shaft of a steam turbine.
- TWO-PHASE SYSTEM.**—An alternating-current system employing two alternating currents, of equal strength, differing in phase by a quarter cycle, or such that one current has maximum strength when the other is passing through zero.
- TWO-WIRE SYSTEM.**—In electric distribution, the system which provides two main conductors, between which lamps, motors or translating devices are connected in parallel.
- VAPOR-LAMP.**—An electric lamp consisting of a glass tube or chamber usually containing mercury and mercury vapor, exhausted of air, and kept illumined by the passage through the vapor of an electric current admitted by electrodes sealed into the walls.
- VOLT, INTERNATIONAL.**—A unit of electric pressure or current-driving electric force, theoretically derived, by electromagnetic principles, from the centimeter-gramme-second system of units. Practically, the international volt is a certain fraction of the electromotive force of a standard type of voltaic cell at a standard temperature.
- VOLTMETER.**—An electrical measuring instrument for determining the value of the electromotive force connected to its terminals. A voltage measurer.
- WATT.**—A unit of power, activity, or rate of working, equal to  $1/746$ th of a horse power, or to 44.4 foot-pounds per minute. The power expended by a current of one ampere under a pressure of one volt. The power expended by an E.M.F. of one volt through a resistance of one ohm. The power expended by one ampere through a resistance of one ohm. Theoretically derived from the centimeter-gramme-second electromagnetic system of units.
- WATT HOUR.**—A unit of work, much used in electrical measurements, equal to the work done in one hour at an activity of one watt; approximately 2,700 foot-pounds; exactly 3,600 joules. The work done by one ampere under one volt pressure, in an hour.
- WATTMETER.**—An instrument connected to an electric circuit and measuring the power delivered to the circuit in watts.
- WHEATSTONE BRIDGE.**—An instrument devised by Sir Charles Wheatstone for measuring electric resistance, by effecting a balance between the resistance to be measured and an adjustable known resistance. The balance employs a bridge or bridging conductor, usually containing a galvanoscope.
- WIRELESS TELEGRAPHY.**—Generally, any method of signaling which does not employ wires. Specifically, the method of signaling which employs invisible electromagnetic waves radiated from a sending station and detected at the receiving station. See **TELEGRAPHY, WIRELESS.**

For definitions of mechanical terms see the articles in this encyclopedia on **MECHANICAL TERMS; BOILER SHOP TERMS; FOUNDRY AND FORGE SHOP TERMS; ENGINE; ENGINEERING AND STRUCTURAL TERMS; TOOLS; VALVE AND VALVE TERMS; WORKSHOP TERMS; and LOCOMOTIVE, PRINCIPAL PARTS OF.**

A. E. KENNELLY,

*Professor of Electrical Engineering, Harvard University.*

**ELECTRICAL UNITS.** Two systems of electrical units are in use by electricians, known respectively as the Practical system and the C. G. S. (centimeter-gramme second) system. The former is used in electrical engineering, the latter in the notation of electrical science. The Practical system is sometimes called the Q. E. S. (quadrant-eleventh-second) system. It is based on the earth quadrant, or  $10^9$  centimeters as the unit of length;  $10^{-11}$  gramme as the unit of mass; and the second as the unit of time. The foundational mechanical units from which the Practical system of electrical units is developed are the dyne and the erg. The dyne is a unit of force, assumed to be that force which gives a weight of one gramme a velocity of one centimeter per second during that second. The erg is a unit of work, being the energy exercised when a weight of one gramme is moved a distance of one centimeter with the force of one dyne.

Arranged alphabetically, the principal units of the Practical system with their definitions and their ratios to the units of the same class in the C. G. S. system are as follows:

**Ampere** (the unit of current)—the rate, or volume-per-second, of current flowing through a conductor in which the resistance is one ohm, when the pressure is one volt. It is one-tenth of the C. G. S. unit of current, designated as  $10^{-1}$ —that is, 10 to the  $-1$  power.

**Coulomb** (the unit of quantity)—the quantity of electricity passing through a conductor in one second when the rate is one ampere. This unit is not often employed.

Quantity is generally designated in ampere hours, an ampere hour being 3,600 coulombs. The coulomb is  $10^{-1}$  C. G. S. units of quantity.

**Farad** (the unit of capacity) — the capacity of a condenser which would require a charge of one coulomb to establish a difference of potential amounting to one volt between the two conductors forming the condenser. The farad being expressed by figures inconveniently large, the micro-farad, the one-millionth part of a farad, is commonly used. A farad is equal to  $10^9$  C. G. S. units of capacity.

**Henry** (the unit of inductance) — the inductance produced in a circuit when the current is changing at the rate of one ampere per second and is producing in the circuit a difference of pressure amounting to one volt. A henry is equal to  $10^9$  C. G. S. units of inductance.

**Joule** (the unit of work) — the work done by one ampere of current flowing for one second through a conductor which has a resistance of one ohm. The joule is seldom employed, the watt hour being the more common unit, equivalent to 3,600 joules. (See WATT). The joule is equal to  $10^7$  C. G. S. units of work — that is,  $10^7$  ergs.

**Ohm** (the unit of resistance) — the resistance of a column of mercury weighing 14.4521 grammes, of such constant cross-section as to be 106.3 centimeters in length. In designating very high resistances the unit used is the "megohm," equivalent to 1,000,000 ohms. The ohm is  $10^9$  C. G. S. units or resistance.

**Volt** (the unit of pressure) — the electromotive force (E. M. F.) required to force a steady current of one ampere against a resistance of one ohm. The volt is equal to  $10^8$  C. G. S. units of pressure.

**Watt** (the unit of power) — a current of one ampere flowing under a pressure of one volt — equivalent to one joule per second. The usual commercial unit is the kilowatt, or 1,000 watts. The commercial consumption of electric current is commonly designated as kilowatt hours. The physical unit of power called one horse power is equivalent to 746 watts. The watt is equal to  $10^7$  C. G. S. units of power — that is,  $10^7$  ergs-per-second.

**ELECTRICITY** is a form of energy (q.v.), like mechanical energy or energy of motion, heat, radiant energy (as light), chemical energy, etc. Electric energy is the form of energy most recently introduced into everyday life and is, therefore, not yet quite familiar, so that we still ask, "What is electricity?" while ages ago mankind ceased to ask, "What is gravity?" or "What is light?" although the manifestations of electric energy are no more wonderful and inexplicable than those of gravity. That is, the cause why a stone falls to the ground and water flows down hill is just as mysterious as the manifestations of electricity. In nature electric energy manifests itself during atmospheric disturbances as lightning (q.v.), but the energy of lightning is too erratic for use. For the production of electric energy on a larger scale recourse must be had to the stores of energy afforded by nature. In large amounts energy is found in nature, first, as mechanical energy in the waterfalls and to a lesser extent the wind, and second, as chemical energy in coal, wood, oil, natural gas, etc.

**Generation.**—In the transformation of the

mechanical energy of waterfalls into electric energy, the water power is first converted into rotary motion by the turbine or water-wheel, the latter then converted into electric energy by the electric generator or dynamo. Chemical energy can be converted directly into electric energy only to a limited extent, as chemical energy of metals. This is done in the electric battery. (See ELECTRIC BATTERY). But due to the high cost of the chemical energy of metals, the production of electric energy by means of the battery is commercially feasible only where small quantities are required and the cost of the energy therefore secondary to the convenience of generation, as for signaling purposes, bells, annunciators, etc. The chemical energy of coal and other combustibles cannot be directly converted into electric energy, but is converted into heat energy by combustion, the heat energy transferred from the gases of combustion to the water in the steam boiler, converted into mechanical energy in the steam engine or steam turbine and the mechanical converted into electric energy in the electric generator. In the gas engine the heat energy of combustion is directly converted into mechanical energy. In any transformation of energy from one form to another a certain loss occurs by conversion into heat. This loss is moderate in the transformation of water power into mechanical energy, very small in the transformation of mechanical into electric energy, but enormous in the transformation of heat into any other form of energy. Our modern theories consider all forms of energy as different modes of motion; of the masses in mechanical energy, or of the molecules and atoms of matter or of the electrons with electric, chemical, etc., energy. Heat is the simplest form of energy, irregular motion of the molecules or motion without definite speed and direction. It is, therefore, intelligible that in any conversion of energy, that is, of a regular motion into another regular motion, some of the energy is lost by losing its regularity of motion, that is, converted into heat, the more the greater the difference between the two forms of motion, and that when converting irregular into regular motion, that is, heat into other forms of energy, this loss is specially great. The cost of electric power derived from water power does not differ much from that derived from coal by the steam engine, the cost of coal in the latter case offsetting the interest on the greater investment required in developing the water power and transmitting the electric power to the place of consumption. Hence where coal is cheap the steam power may be more economical, and where water power is found which can cheaply be developed, or where coal is expensive, water power is more economical.

**Use.**—Electric energy is hardly ever used as such, but only after transformation into other forms of energy, mainly mechanical energy, heat, chemical energy and light. Since electric energy is generated from other forms of energy, it follows that it is used essentially as an intermediary form of energy. For this it is better suited than any other form of energy, due to the high efficiency and simplicity of generation and reconversion and especially the almost unlimited flexibility which permits transmission over long distance, distribution with the simplest means and unlimited subdivision and ease of control.

**Mechanical Power.**—The electric motor is a secondary and not a primary source of power, that is, it does not convert the stores of energy found in nature into mechanical energy as the steam engine, but mechanical power has to be exerted somewhere to produce the electric power which is reconverted into mechanical power in the electric motor. The advantage of the electric motor is that the mechanical power can be utilized at a distance from the source of power; the factories and mills may be located far distant from the water power and the railroad train or street car receive the power from the distant station. The power generated at one place can be distributed efficiently to a large number of places, or all motors of the city may receive their power from one central generating station. Instead of an extended and inefficient system of belting, individual motors may drive the machines of the factory or mill. All the cars or trains of a railway system may receive their power from one generating system, perhaps a water-power as Niagara. The electric motor is under more perfect control than almost any other motor, and when not used consumes no power and requires no special care in starting and operation. Mechanical power in small quantities can be produced almost as efficiently as in large units and a great subdivision of power becomes thereby feasible. In the field of mechanical power generated by electricity also belong telegraphy and telephony, or the transmission of signals and speech over long distances.

**Light.**—For lighting, electric energy usually is first converted into heat and the light given by the incandescence of very refractory solid substances, carbon or tungsten (wolfram), the tungsten wire or carbon filament of the incandescent lamp, or the glowing tip or crater of the arc lamp carbons. (See ELECTRIC LIGHTING). Here again, especially with incandescent lamps, the main advantage lies in the absolute steadiness, control and flexibility of the light, the simplicity of turning it on or off, and its relatively high efficiency, which gives a light with less heat than the gas flame or kerosene lamp. While due to the use of heat as intermediary form of energy only a very few per cent of the electric energy are converted into light, most being dissipated as heat, with the gas or kerosene flame the percentage of energy converted into light is still much less. Recently considerable work is being done and with great promise of converting electric energy more directly into light by electro-luminescence in luminous arcs, which promise an efficiency of light production very much greater than the incandescent or carbon arc lamp, and there is a possibility of still very much higher efficiencies of light production by electro fluorescence.

**Heat.**—The conversion of electric energy into heat means a degradation of energy from regular to irregular motion and in the heat production by electric energy only a very few per cent of the heat energy expended under the boilers of the steam engine driving the electric generator is recovered, so that electric heating is usually more expensive than direct generation of heat by combustion and therefore commercially practicable only:

1. For the production of temperatures beyond those which can be reached by combustion. At very high temperatures chemical affini-

ty and therefore combustion ceases and temperatures beyond this cannot be reached by combustion but are reached by conversion of electric energy into heat in the electric furnace. By this means chemical compounds have been produced for industrial purposes which were either entirely unknown or mere curiosities before, as the carbides, calcium carbide, carborundum, silicon metal, etc.

2. Electric energy is used for heating where the temperature has to be perfectly controlled.

3. For intermittent use, such as flat-irons, etc., where heat production by combustion is inefficient.

4. Due to its convenience and cleanliness for domestic uses to a limited extent, electric heating and cooking are coming into use.

**Chemical Energy.**—Electric energy is converted into chemical energy either directly in the electrolytic cell or indirectly with heat as intermediary in the electric furnace as discussed above. Electrolysis (q.v.), that is, the chemical action of electric energy, is used exclusively for the production of aluminum, magnesium, calcium, etc., metal, is used for copper refining, production of sodium, chlorates, soda and bleaching powder, and many other compounds.

**Storage.**—Electric energy cannot be stored as such conveniently, but the ease and efficiency of conversion of electric energy into the chemical energy of metals and metallic oxides, and inversely, permits the storage of electric energy as chemical energy in the storage battery. (See ELECTRIC STORAGE BATTERY). Charging the storage battery means converting in it electric energy into chemical energy, discharging, the reversion of the chemical energy into electric energy.

**Forms of Electric Energy.**—Electric energy is used as direct current, as alternating current and as high frequency current. In the direct current circuit, the electric current continuously flows in the same direction, and the electric pressure or voltage therefore also is constantly in the same direction. Direct current is required for electrolytic work, therefore also for the charging of storage batteries. It is generally preferred for electric railroading, and often for electric lighting, especially where the demand is very concentrated, as in the centres of large cities. All electric batteries give direct current. Electric generators or motors may be built for direct current as well as for alternating current. In the alternating current circuit, the electric current and thus the electric pressure reverses periodically, usually 120 or 50 times per second, and the number of double reversals or cycles per second is called the frequency of the alternating current. Sixty and 25 cycles per second are the standard frequencies. Usually several alternating currents are used in the same system, which reverse successively, and the system then is called a three-phase system, if three, a quarter-phase system, if two successively reversing currents are employed. If only one current is used, the system is called single-phase. Alternating currents have the advantage that they can be raised in voltage by stationary apparatus, so-called "transformers," for transmission to a distance, and lowered in voltage for use. They are therefore more flexible in application, and for this reason all large electric generating systems now produce alternating currents, and where direct current is re-

quired, it is produced from the alternating current supply by rotary transforming devices, so-called "converters," or stationary devices, so-called "rectifiers."

High frequency currents are alternating currents reversing very rapidly, often a hundred thousand or million times per second. Often they are not constant in value, but die out and then start over again, so-called "oscillating currents." They are mainly used for wireless telegraphy and telephony.

**Measurements.**—Since all forms of energy are convertible into each other they can be measured by the same measure. Heat being the simplest form of energy, the measure of heat has been the usual measure of energy. It is the calorie, or the amount of heat required to raise one litre of water from 0° to 1°C, or the British Thermal Unit (B.T.U.), that is, the amount of heat required to raise one pound of water by 1° F. However, due to the far greater convenience and exactness of electrical measurements, the electrical unit of energy, the joule or watt second (one watt equals one volt times one ampere) is rapidly replacing the thermal unit or calorie, even in chemistry. Generally, the kilo-joule, or thousand joules, is used. Other forms of energy usually have some measure, convertible into calories or into joules. So, mechanical energy is measured in foot-pounds, or kilogram-metres, and the flow of mechanical energy, or mechanical power, in foot-pounds per second or horse power, 1 horse power = 550 foot-pounds per second, = 76 kilogram-metres per second = .178 calorie seconds. The value of electric energy or electric power is measured either in the mechanical measure, horse power, or electric measure, watts, 746 watts = 1 horse power. Usually the kilowatt or 1,000 watts = 1.34 horse power, is used. 1 kilowatt = 238 calorie second. 1 kilowatt second = 1 kilojoule (KJ). Most forms of energy are resolved into the product of two components; a quantity and a pressure component, as the power of a waterfall is the product of the quantity of water flowing and its head or fall. So electric power is resolved into a quantity component called "current" and measured in amperes, and a pressure component called "electromotive force" or "potential difference" or "voltage," and measured in volts, and the electric power then is a product of volts and amperes, 1 watt = 1 volt × 1 ampere and one joule = 1 watt × 1 second is the electric energy. Just as a small quantity of water under a high head may give the same power as a large quantity under low head, so a small current at high voltage may represent the same electric power as a large current under low voltage. The smaller the quantity and the higher the voltage the less the loss in transmitting the power. Therefore, for long distance transmissions high voltages are used, the higher the greater the distance, while relatively low voltages are employed for general use, due to the difficulty and danger of handling high voltages. The instrument measuring electric power is called the wattmeter, that measuring electric current or flow of quantity is the ammeter, that measuring electric pressure or voltage is the voltmeter.

**Conductors and Insulators.**—Some substances, as metals, carbon, salt solutions, etc., are conductors of electricity, others as air, glass, rubber, paper, oils, etc., are insulators. There

is, however, no perfect conductor nor perfect insulator, but even the best conductors, silver, copper, aluminum, offer still some resistance to the flow of electric power and thereby cause a loss of energy which is proportional to the square of the current flowing and appears as heat in the conductor. For transmission of electric power conductors are therefore used to direct the flow of power, copper or aluminum, surrounded by insulators, as rubber, paper. It is not sufficient, however, merely to surround the conductor by insulating material, but the insulating material must have sufficient thickness to withstand the electric pressure or voltage, otherwise it is disrupted, that is, the electric power penetrates it as spark discharge. The ability to withstand electric pressures is called the dielectric or disruptive strength and is of foremost importance in insulating electric circuits of high voltage. Very good insulators are not necessarily of very high dielectric strength, for instance air, which is perhaps the best insulator, has rather low disruptive strength, that is, is easily penetrated by an electric spark, while mica and rubber, although not as good insulators as air, have very much greater dielectric strength.

**Physiological Effects.**—Electric energy is perceived by the senses either indirectly by transformation into other forms of energy, as light and sound in the spark discharge or lightning, or directly if the electric current passes through the body. A large current of very short duration, or electric discharge, causes a shock which when very powerful, as in lightning, may be fatal. A current flowing continuously through the body causes a specific sensation which with increasing voltage and therefore increasing current becomes unbearable, the muscles contract and become uncontrollable, so that in case of accidental contact with electric circuits the victim is unable to let go, and ultimately at high voltages death may result. With alternating currents, the specific sensation decreases with increasing frequency, so that at very high frequencies even large currents are little felt—though not without danger. (See ELECTRICITY, CAUSE OF DEATH BY). The amount of current flowing through the body depends upon the electric pressure or voltage and the resistance of the body. This resistance is mainly the skin or surface resistance, therefore depends upon the nature of the contact between body and electric circuit. When loosely touched with dry hands a 100-volt circuit may hardly give any sensation, while grasped with wet hands a 50-volt circuit may be unbearable. Only at very high voltages the nature of the contact becomes of less importance and the electric current penetrates as arc. Electric pressures below 500 to 600 volts are considered as still safe, since only in cases of exceptionally good contact with such voltages serious results may occur. Much higher voltages are usually fatal, but instances are on record of contact with 10,000 to 20,000 volts without fatal results, in cases where the duration of the contact has been very brief.

The causes of death by electricity are:

1. The direct effect of large power exerted upon the body, causing destruction by heat, etc., as in electrocution where several horse power are used.
2. Mechanical destruction of vital organs by very heavy discharges, as lightning.



3. Paralysis of the nervous system, stoppage of the heart and respiratory organs. In these cases resuscitation by artificial respiration, etc., when immediately resorted to, is very promising, especially if only respiration has stopped, but the heart is still beating.

Therapeutically electricity is used as stimulant by its action on the nervous system and for carrying substances through the skin into the body electro-chemically. It is very useful in the hands of expert physicians but like any powerful agent, in the hands of a layman, is harmful and dangerous. The electric healing devices advertised broadcast, as electric belts, etc., are mere swindles and without any value. See ELECTROTHERAPEUTICS.

**Prospect.**—Only the very beginning has been made in the use of electricity as secondary form of power for transmitting energy from its natural source, waterfall or coal mine, to the place of consumption, factory, city, railway. Here very great strides are still to be looked forward to, resulting in a much more efficient use of the stores of energy afforded by nature. The essential characteristic of modern civilization is the independence of man of his immediate surroundings, in the necessities of civilized life. These necessities are materials and energy. The transportation, distribution and supply of materials has been organized in the last century in the system of railway, steamship and other transportation agencies, and the generation, transmission, distribution and supply of energy is now being organized by electric power, in the system or network of transmission and distribution lines, which increasingly spread over the country and interconnect the electric power generating stations—steam and hydraulic—with the places of energy demand. Only electricity can fulfil this requirement of energy supply of our civilization, due to the high efficiency and economy of electric transmission, the practically unlimited possibility of subdivision in distribution, and the efficiency and simplicity of conversion of electric energy into any other form of energy, from the small lamp of a few watts power consumption, to the huge motor of many thousand horse power. In the production of light from electric energy at present the efficiency is low, due to the use of heat as intermediary form of energy. A direct conversion of electric energy into light giving an efficiency of 50 per cent or more would make electric lighting many times cheaper than any other form of illumination and so displace all other illuminants. In this direction fair promise of a gradual advance exists. The direct conversion of the stored energy of coal into electric energy and thereby the elimination of the enormous loss of energy between the chemical energy of the coal and the electric energy is still entirely hopeless and no clue to its solution visible. In electro-chemistry (q.v.), that is, the transformation of electric into chemical energy, lies an enormous field which has already produced powerful industries, as the aluminum and carbide production, and therefore holds out the hope of most wonderful advances in the future. See ELECTROCHEMICAL INDUSTRIES; METALLURGY; and various other articles in this volume on electrical subjects.

CHARLES P. STEINMETZ,

*General Electric Company, Schenectady, N. Y.*

**ELECTRICITY, Its History and Progress.** There is perhaps no better illustration of the slow growth of man's knowledge concerning physical things than the fact that the identity of lightning and electricity in some of its other modes of manifestation should have escaped detection for so many centuries of the world's history.

Lightning, of course, and certain other manifestations of electricity, were known to the philosophers of ancient times, but to them no thought was more remote than that these manifestations had a common origin. Pliny (61–115 A.D.) in his books writes: "The ancient Tuscans by their learning hold that there are nine gods that send forth lightning and those of eleven sorts." This was in general the early pagan idea of lightning. The property of amber when rubbed of attracting light bodies, such as particles of feathers, a property now known to be electrical in its nature, must have been familiar to philosophers many hundred years before the Christian era, although Thales of Miletus (640–548 B.C.), one of the seven sages of Greece, is mentioned as having been the first to observe this phenomenon. Pliny has several references to this peculiar property of amber. Pliny's 'Natural History,' (trans. Philemon Holland, London 1634, pp. 606, 608, 609).

The peculiarity of the torpedo in defending itself by means of a property, now also known to be electrical, which it possesses whereby it can stun an enemy, was also known to Pliny and other early writers. Consult Cavallo's 'Philosophy,' p. 536 (Philadelphia 1829).

The property of the magnet or loadstone in attracting iron was likewise known to the enlightened men of that early period, but neither in the case of electricity nor of magnetism had these philosophers any conception of the real nature of the phenomena involved, attributing the peculiar properties of the substances named to some occult vitality possessed by them.

It is not, however, much to be wondered at that the philosophers of long past ages should have failed to observe any relationship between the electricity of lightning, amber and the torpedo, when as we shall see, many who may be termed modern philosophers—those of the 17th and 18th centuries—failed for years to discover this identity, even when in possession of electric machines capable of producing in miniature many of the effects of lightning, and for long after the knowledge of the electrical properties of amber had been extended to wax, glass and other substances. Even the corelationship of electricity and magnetism escaped particular notice for some years after the affinity of these phenomena had been demonstrated. Possibly the earliest and nearest approach to the discovery of the identity of lightning, and electricity from any other source, is to be attributed to the Arabs, who before the 15th century had applied the Arabic word for lightning (raad) to the torpedo. The Greek word for amber, however, is elektron, and it is due to the fact that this substance was the first known to possess the property mentioned that the word electricity is derived.

Centuries passed after the discovery of frictional and animal electricity before any advance appears to have been made in the production of electricity artificially or before any important developments of value were made in the art.

Toward the latter part of the 16th century a physician of Queen Elizabeth's time, Dr. William Gilbert (1540-1603), undertook a number of careful electrical experiments, in the course of which he discovered that many substances other than amber, such as sulphur, wax, glass, etc. (consult Priestley's 'History of Electricity,' London 1757), were capable of manifesting electrical properties. Gilbert also discovered that a heated body lost its electricity and that moisture prevented the electrification of all bodies, due to the now well-known fact that moisture impaired the insulation of such bodies. He also noticed that electrified substances attracted all other substances indiscriminately, whereas a magnet only attracted iron. The many discoveries of this nature earned for Gilbert the title of founder of the electrical science. Since Gilbert's time scarcely a year has passed in which some new discovery relating to the science and art of electricity and magnetism has not been made. This is especially true during the years since 1872.

Amongst the experimenters immediately following Gilbert one of the most notable was Dr. Wall of England (1650). During one of his experiments on approaching his fingers to an electrified rod, Dr. Wall saw a spark, accompanied by a noise which he likened to lightning and thunder. Wall's contemporaries and some comparatively recent writers have thought that this was the first time an artificially produced electric spark had been observed. This, however, is doubtless an erroneous view. Archbishop Eustathias, of Thessalonica, Greek scholar and writer of the 12th century, for instance records that Woliver, king of the Goths, was able to draw sparks from his body. The same writer states that a certain philosopher was able while dressing to draw sparks from his clothes, a result seemingly akin to that obtained by Symmer in his silk stocking experiments, a careful account of which may be found in the 'Philosophical Transactions,' 1759.

It would indeed have been surprising if the electric spark had not been observed prior to Dr. Wall's time (although its origin may not have been recognized) when it is considered that any one shuffling across a carpet in dry, crisp weather, or if whipped with a piece of fur while his body is insulated, will accumulate a charge of electricity upon his person that will discharge with a spark into any other person or piece of metal that he may touch. The present writer has even noticed electric sparks passing from his knuckles to the metal fixings of a hand bag that he was carrying while walking on a stone pavement in cold, dry weather.

Robert Boyle was another of the experimenters in electricity of this period (1650). One of his important discoveries was that electrified bodies in a vacuum would attract light substances, this indicating that the electrical effect did not depend upon the air as a medium. He also added resin to the then known list of electrics. (Consult Boyle's 'Experiments on the Origin of Electricity,' and Priestley's 'History of Electricity'). Up to about the year 1682 the only known way in which electricity could be developed was virtually that known to the ancients, namely, by rubbing rods of amber, glass, wax, resin or similar substances. The amount of electricity producible in this way was very

small. At this time Otto von Guericke of Magdeburg (also the inventor of the air-pump) invented an electric machine consisting of a sulphur globe or ball, suitably mounted on a shaft and rotated by a handle. Using his hand as a "rubber" (see ELECTRIC MACHINE), von Guericke obtained electricity in fairly large quantities, the production of which was accompanied by light and sound.

The electric machine was subsequently improved by Hawkesbee or Haukesbee, Litzendorf, and by Prof. George Mathias Boze, about 1750. Litzendorf substituted a glass ball for the sulphur ball of Guericke. Boze was the first to employ the "prime conductor" in such machines, this consisting of an iron rod held in the hand of a person whose body was insulated by standing on a cake of resin. Dr. Ingenhousz, in 1746, invented electric machines made of plate glass. Consult Dr. Carpué's 'Introduction to Electricity and Galvanism,' London 1803.

Experiments with the electric machine were largely aided by the discovery of the property of a glass plate, when coated on both sides with tinfoil, of accumulating a charge of electricity when connected with a source of electromotive force. This property, now and for many years availed of in the electric condenser, was, according to Priestley ('History of Electricity,' 3d ed., Vol. I, p. 102), first observed by Von Kleist of Leyden in 1754. Von Kleist happened to hold, near his electric machine, a small bottle, in the neck of which there was an iron nail. Touching the iron nail accidentally with his other hand he received a severe electric shock. In much the same way Prof. Pieter van Musschenbroeck assisted by Cunaens received a more severe shock from a somewhat similar glass bottle. Sir William Watson of England greatly improved this device, by covering the bottle, or jar, outside and in with tinfoil. This piece of electrical apparatus will be easily recognized as the well-known Leyden jar, so called by the Abbot Nollet of Paris, after the place of its discovery. The electric machine was soon further improved by Prof. Andrew Gordon, a Scotchman, of Erfurt, who substituted a glass cylinder in place of a glass globe; and by Giessing of Leipzig who added a "rubber" consisting of a cushion of woollen material. The "collector," consisting of a series of metal points, was added to the machine by Benjamin Wilson about 1746, and Mr. John Canton of England (also the originator of the first pith ball electrometer) in 1762 made a notable improvement in the efficiency of electric machines by sprinkling an amalgam of tin over the surface of the rubber.

In the second quarter of the 18th century (1729) Stephen Gray in a series of interesting experiments for the first time demonstrated the difference between conductors and non-conductors (insulators), showing amongst other things that a metal wire and even pack thread conducted electricity, whereas silk did not. In one of his experiments he sent an electric current through 700 feet of hempen thread which was suspended at intervals by loops of silk thread; probably explainable on supposition that the hemp is more absorbent of moisture than silk. Subsequently Du Fay transmitted a current through a wet hempen string to a distance of 1,256 feet, the string being insulated by means of glass. In 1741 Mr. Ellicott "pro-

posed to measure the strength of electrification by its power to raise a weight in one scale of a balance while the other was held over the electrified body and pulled to it by its attractive power" (Carpue).

The Sir William Watson already mentioned conducted numerous experiments, about 1749, to ascertain the velocity of electricity in a wire, which experiments, although perhaps not so intended, also demonstrated the possibility of transmitting signals to a distance by electricity. In these experiments an insulated wire 12,276 feet in length was employed and the transmission of a signal from one end of the wire to the other appeared to the observers to be instantaneous. Monnier in France had previously made somewhat similar experiments, sending shocks through an iron wire 1,319 feet long.

About 1737 Hawkesbee and Du Fay independently discovered that there were apparently two kinds of frictional electricity namely, that which is developed by rubbing glass and resin, respectively. The former electricity Du Fay termed "vitreous," the latter "resinous" electricity. Later, these electricities were termed "positive" and "negative" electricity, respectively, by Franklin, Dr. Watson, Lichtenberg and others.

Theories regarding the nature of electricity were quite vague at this period, and those prevalent were more or less conflicting. Franklin considered that electricity was an imponderable fluid pervading everything, and which, in its normal condition, was uniformly distributed in all substances. He assumed that the electrical manifestations obtained by rubbing glass were due to the production of an excess of the electric fluid in that substance and that the manifestations produced by rubbing wax were due to a deficit of the fluid. This theory was opposed by the "two-fluid" theory due to Robert Symmer, 1759. By Symmer's theory the vitreous and resinous electricities were regarded as imponderable fluids, each fluid being composed of mutually repellent particles while the particles of the opposite electricities are mutually attractive. When the two fluids unite by reason of their attraction for one another, their effect upon external objects is neutralized. The act of rubbing a body decomposes the fluids one of which remains in excess on the body and manifests itself as vitreous or resinous electricity.

About 1750 various tests were made by different experimenters to ascertain the physiological and therapeutical effects of electricity. Mainbray (or Mowbray) in Edinburgh examined the effects of electricity upon plants and concluded that the growth of two myrtle trees was quickened by electrification. These myrtles were electrified "during the whole month of October, 1746, and they put forth branches and blossoms sooner than other shrubs of the same kind not electrified." (Priestley's 'History of Electricity,' p. 138). The Abbé Menon tried the effects of a continued application of electricity upon men and birds and found that the subjects experimented on lost weight, thus apparently showing that electricity quickened the excretions. The efficacy of electric shocks in cases of paralysis was tested in the county hospital at Shrewsbury, England, with rather poor success. ('Philosophical Transactions,' p. 786, 1754). In one case reported a palsied

arm was somewhat improved, but the dread of the shocks became so great that the patient preferred to forego a possible cure rather than undergo further treatment. In another case of partial paralysis the electric treatment was followed by temporary total paralysis. A second application of this treatment was again followed by total paralysis, whereupon the further use of electricity in this case was stopped. For further accounts of the early use of electricity as a remedial agent the reader may consult De la Rive's 'Electricity.' See also article ELECTROTHERAPEUTICS.

Up to the time of Franklin's historic kite experiment (see ELECTRICITY, ATMOSPHERIC) the identity of the electricity developed by rubbing and by electric machines (frictional electricity), with lightning had not been generally established. Dr. Wall, 1807, Abbot Nollet, Hawkesbee, Gray and Winckler had indeed suggested the resemblance between the phenomena of "electricity" and "lightning," Gray having intimated that they only differed in degree. It was doubtless Franklin, however, who first proposed tests to determine the sameness of the phenomena. In a letter to Peter Comlinson, London, 19 Oct. 1752. Franklin, referring to his kite experiment, wrote, "At this key the phial (Leyden jar) may be charged; and from the electric fire thus obtained spirits may be kindled, and all the other electric experiments be formed which are usually done by the help of a rubbed glass globe or tube, and thereby the sameness of the electric matter with that of lightning be completely demonstrated." (Franklin, 'Experiments and Observations on Electricity'). Dalibard, at Marley, near Paris, on 10 May 1742, by means of a vertical iron rod 40 feet long, obtained results corresponding to those recorded by Franklin and somewhat prior to the date of Franklin's experiment.

Franklin's important demonstration of the sameness of frictional electricity and lightning doubtless added zest to the efforts of the many experimenters in this field in the last half of the 18th century, to advance the progress of the science. Amongst those workers may be mentioned Watson, Boze, Smeaton, Le Monnier, De Romas, Jallabert, Beccaria, Cavallo, John Canton, Robert Symmer, Nollet, Winckler, Richman, Dr. Wilson, Kinnersley, Priestley, Aepinus, Delaval, Cavendish, Coulomb, Volta and Galvani. A description of many of the experiments and discoveries of these early workers in the fields of electrical science and art will be found in the scientific publications of the time; notably the 'Philosophical Transactions,' *Philosophical Magazine*, *Cambridge Mathematical Journal*, Young's 'Natural Philosophy,' Priestley's 'History of Electricity,' Franklin's 'Experiments and Observations on Electricity,' Cavalli's 'Treatise on Electricity,' De la Rive's 'Treatise on Electricity.' Among the more important of the electrical experiments and researches at this period were those of Francis Aepinus, a noted German scholar (1724-1802) and Henry Cavendish of London, England. To Aepinus is accorded the credit of having been the first to conceive the view of the reciprocal relationship of electricity and magnetism. In his work ('Tentamen Theoria Electricitatis et Magnetismi,' published in Saint Petersburg, 1759, he gives the following amplification of Franklin's theory, which in some of

its features is measurably in accord with present day views: "*The particles of the electric fluid repel each other and attract and are attracted by the particles of all bodies with a force that decreases in proportion as the distance increases; the electric fluid exists in the pores of bodies; it moves unobstructedly through non-electric (conductors), but moves with difficulty in insulators; the manifestations of electricity are due to the unequal distribution of the fluid in a body, or to the approach of bodies unequally charged with the fluid.*" Aepinus formulated a corresponding theory of magnetism excepting that in the case of magnetic phenomena the fluids only acted on the particles of iron. He also made numerous electrical experiments, amongst others those apparently showing that in order to manifest electrical effects tourmalin requires to be heated to a temperature between 37.5° C and 100° C. In fact, tourmalin remains unelectricified when its temperature is uniform, but manifests electrical properties when its temperature is rising or falling. Crystals which manifest electrical properties in this way are termed pyro-electrics, amongst which, besides tourmalin, are sulphate of quinine and quartz.

Cavendish independently conceived a theory of electricity nearly akin to that of Aepinus ('Philosophical Transactions,' 1771). He also (1784) was perhaps the first to utilize the electric spark to produce the explosion of hydrogen and oxygen in the proper proportions to produce pure water. The same philosopher also discovered the inductive capacity of dielectrics (insulators) and as early as 1775 measured the specific inductive capacity for beeswax and other substances by comparison with an air condenser.

About 1784 C. A. Coulomb, after whom is named the electrical unit of quantity, devised the torsion balance, by means of which he discovered what is known as Coulomb's law;—*The force exerted between two small electrified bodies varies inversely as the square of the distance*; not as Aepinus in his theory of electricity had assumed, merely inversely as the distance. According to the theory advanced by Cavendish "*the particles attract and are attracted inversely as some less power of the distance than the cube.*"

With the discovery, by the experiments of Watson and others, that electricity could be transmitted to a distance, the idea of making practical use of this phenomenon began, about 1753, to engross the minds of "inquisitive" persons, and to this end suggestions looking to the employment of electricity in the transmission of intelligence were made. The first of the methods devised for this purpose was probably that, due to Lesage (1774). This method consisted in the employment of 24 wires, insulated from one another and each of which had a pith ball connected to its distant end. Each wire represented a letter of the alphabet. To send a message, a desired wire was charged momentarily with electricity from an electric machine, whereupon the pith ball connected to that wire would fly out; and in this way messages were transmitted. Other methods of telegraphing in which frictional electricity was employed were also tried, some of which are described in the article on the telegraph (q.v.).

Hitherto the only electricity known was that developed by friction or rubbing, which was therefore termed frictional electricity. We now come to the era of galvanic or voltaic electricity. The first mention of voltaic electricity, although not recognized as such at the time, was probably made by Sulzer in 1767, who on placing a small disc of zinc under his tongue and a small disc of copper over it, observed a peculiar taste when the respective metals touched at their edges. Sulzer assumed that when the metals came together they were set into vibration, this acting upon the nerves of the tongue, producing the effects noticed.

In 1790 Prof. Luigi Alvisio Galvani of Bologna on one occasion, while conducting experiments on "animal electricity," as he termed it, to which his attention had been turned by the twitching of a frog's legs in the presence of an electric machine, observed that the muscles of a frog which was suspended on an iron balustrade by a copper hook that passed through its dorsal column underwent lively convulsions without any extraneous cause; the electric machine being at this time absent. To account for this phenomenon Galvani assumed that electricity of opposite kinds existed in the nerves and muscles of the frog; the muscles and nerves constituting the charged coatings of a Leyden jar.

Galvani published the results of his discoveries, together with his hypothesis, which at once engrossed the attention of the physicists of that time; the most prominent of whom, Alexander Volta, professor of physics at Pavia, contended that the results observed by Galvani were due to the two metals, copper and iron, acting as "electromotors," and that the muscles of the frog played the part of a conductor, completing the circuit.

This precipitated a long discussion between the adherents of the conflicting views; one set of adherents holding with Volta that the electric current was the result of an electromotive force of contact at the two metals; the other set adopting a modification of Galvani's view and asserting that the current was due to a chemical affinity between the metals and the acids in the pile. Michael Faraday wrote in the preface to his 'Experimental Researches,' relative to the question whether metallic contact is or is not productive of a part of the electricity of the voltaic pile: "I see no reason as yet to alter the opinion I have given; . . . but the point itself is of such great importance that I intend at the first opportunity renewing the inquiry, and, if I can, rendering the proofs either on the one side or the other, undeniable to all." Even Faraday himself, however, did not settle the controversy, and while the views of the advocates on both sides of the question have undergone modifications, as subsequent investigations and discoveries demanded, up to the present day diversity of opinion on these points continues to crop out.

Volta made numerous experiments in support of his theory and ultimately developed the pile or battery (see VOLTAIC PILE), which was the precursor of all subsequent chemical batteries, and possessed the distinguishing merit of being the first means by which a prolonged continuous current of electricity was obtainable.

Volta communicated a description of his pile to the Royal Society of London and shortly thereafter Nicholson and Cavendish (1780) produced the decomposition of water by means of the electric current, using Volta's pile as the source of electromotive force. Davy in 1806, employing a voltaic pile of approximately 250 cells, or couples, decomposed potash and soda, showing that these substances were respectively the oxides of potassium and sodium, which metals previously had been unknown. These experiments were the beginning of electrochemistry (q.v.), the investigation of which Faraday took up, and concerning which in 1833 he announced his important law of electrochemical equivalents, viz.: "*The same quantity of electricity—that is, the same electric current—decomposes chemically equivalent quantities of all the bodies which it traverses; hence the weights of elements separated in these electrolytes are to each other as their chemical equivalents.*" Employing a battery of 2,000 elements of a voltaic pile Humphrey Davy in 1809 gave the first public demonstration of the electric arc light (q. v.), using for the purpose charcoal enclosed in a vacuum.

Somewhat singular to note, it was not until many years after the discovery of the voltaic pile that the sameness of annual and frictional electricity with voltaic electricity was clearly recognized and demonstrated. Thus as late as January 1833 we find Faraday writing ('*Philosophical Transactions*, 1833) in a paper on the electricity of the torpedo. "After an examination of the experiments of Walsh, Ingenhousz, Cavendish, Sir H. Davy, and Dr. Davy, no doubt remains on my mind as to the identity of the electricity of the torpedo with common (frictional) and voltaic electricity; and I presume that so little will remain on the mind of others as to justify my refraining from entering at length into the philosophical proof of that identity. The doubts raised by Sir H. Davy have been removed by his brother, Dr. Davy; the results of the latter being the reverse of those of the former. . . . The general conclusion which must, I think, be drawn from this collection of facts (a table showing the similarity of properties of the diversely named electricities) is, that electricity, whatever may be its source, is identical in its nature."

It is proper to state, however, that prior to Faraday's time the similarity of electricity derived from different sources was more than suspected. Thus, William Hyde Wollaston, b. 1766; d. 1828 (another noted and careful experimenter in electricity and the discoverer of palladium and rhodium), wrote in 1801 (*Philosophical Magazine*, Vol. III, p. 211): "This similarity in the means by which both electricity and galvanism (voltaic electricity) appear to be excited in addition to the resemblance that has been traced between their effects shows that they are both essentially the same and confirm an opinion that has already been advanced by others, that all the differences discoverable in the effects of the latter may be owing to its being less intense, but produced in much larger quantity." In the same paper Wollaston describes certain experiments in which he uses very fine wire in a solution of sulphate of copper through which he passed electric currents from an electric machine. This is interesting in connection with the later day use of almost similarly ar-

ranged fine wires in electrolytic receivers in wireless, or radio-telegraphy.

In the first half of the 19th century many very important additions were made to the world's knowledge concerning electricity and magnetism. For example, in 1819 Hans Christian Oersted of Copenhagen discovered the deflecting effect of an electric current traversing a wire upon a suspended magnetic needle. This discovery gave a clue to the subsequently proved intimate relationship between electricity and magnetism which was promptly followed up by Ampère who shortly thereafter (1821) announced his celebrated theory of electro-dynamics, relating to the force that one current exerts upon another, by its electro-magnetic effects, namely: (1) "*Two parallel portions of a circuit attract one another if the currents in them are flowing in the same direction, and repel one another if the currents flow in the opposite direction.*" (2) "*Two portions of circuits crossing one another obliquely attract one another if both the currents flow either towards or from the point of crossing, and repel one another if one flows to and the other from that point.*" (3) "*When an element of a circuit exerts a force on another element of a circuit, that force always tends to urge the latter in a direction at right angles to its own direction.*"

Professor Seebeck, of Berlin, in 1821 discovered that when heat is applied to the junction of two metals that had been soldered together an electric current is set up. This is termed Thermo-Electricity. (See THERMO-ELECTRICITY). Seebeck's device consists of a strip of copper bent at each end and soldered to a plate of bismuth. A magnetic needle is placed parallel with the copper strip. When the heat of a lamp is applied to the junction of the copper and bismuth an electric current is set up which deflects the needle.

Peltier in 1834 discovered an effect opposite to the foregoing, namely, that when a current is passed through a couple of dissimilar metals the temperature is lowered or raised at the junction of the metals, depending on the direction of the current. This is termed the Peltier "effect." The variations of temperature are found to be proportional to the strength of the current and not to the square of the strength of the current as in the case of heat due to the ordinary resistance of a conductor. This latter is the C<sup>2</sup>R law, discovered experimentally in 1841 by the English physicist, Joule. In other words, this important law is that the heat generated in any part of an electric circuit is directly proportional to the product of the resistance of this part of the circuit and to the square of the strength of current flowing in the circuit.

In 1822 Schweigger devised the first galvanometer (q.v.). This instrument was subsequently much improved by Wilhelm Weber (1833). In 1825 William Sturgeon of Woolwich, England, invented the horseshoe and straight bar electromagnet, receiving therefor the silver medal of the Society of Arts ('*Trans. Society of Arts*, 1825). In 1837 Gauss and Weber (both noted workers of this period) jointly invented a reflecting galvanometer for telegraph purposes. This was the forerunner of the Thomson reflecting and other exceedingly sensitive galvanometers once used in submarine signaling and still widely employed in electrical measurements. Arago in 1824 made the im-

portant discovery that when a copper disc is rotated in its own plane, and if a magnetic needle be freely suspended on a pivot over the disc, the needle will rotate with the disc. If on the other hand the needle is fixed it will tend to retard the motion of the disc. This effect was termed Arago's rotations. Futile attempts were made by Babbage, Barlow, Herschel and others to explain this phenomenon. The true explanation was reserved for Faraday, namely, that electric currents are induced in the copper disc by the cutting of the magnetic lines of force of the needle, which currents in turn react on the needle. In 1827 George Simon Ohm (q.v.) announced the now famous law that bears his name, that is:

$$\text{Current} = \frac{\text{Electromotive force}}{\text{Resistance.}}$$

In 1831 began the epoch-making researches of Michael Faraday (q.v.), the famous pupil and successor of Humphrey Davy (q.v.) at the head of the Royal Institution, London, relating to electric and electromagnetic induction.

Faraday's studies and researches extended from 1831 to 1855 and a detailed description of his experiments, deductions and speculations are to be found in his compiled papers, entitled 'Experimental Researches in Electricity.' Faraday was by profession a chemist. He was not in the remotest degree a mathematician in the ordinary sense—indeed it is a quest on if in all his writings there is a single mathematical formula.

The experiment which led Faraday to the discovery of electric induction was made as follows: He constructed what is now and was then termed an induction coil, the primary and secondary wires of which were wound on a wooden bobbin, side by side, and insulated from one another. In the circuit of the primary wire he placed a battery of approximately 100 cells. In the secondary wire he inserted a galvanometer. On making his first test he observed no results, the galvanometer remaining quiescent, but on increasing the length of the wires he noticed a deflection of the galvanometer in the secondary wire when the circuit of the primary wire was made and broken. This was the first observed instance of the development of electromotive force by electromagnetic induction. He also discovered that induced currents are established in a second closed circuit when the current strength is varied in the first wire, and that the direction of the current in the secondary circuit is opposite to that in the first circuit. Also that a current is induced in a secondary circuit when another circuit carrying a current is moved to and from the first circuit, and that the approach or withdrawal of a magnet to or from a closed circuit induces momentary currents in the latter. In short, within the space of a few months Faraday discovered by experiment virtually all the laws and facts now known concerning electro-magnetic induction and magneto-electric induction. Upon these discoveries, with scarcely an exception, depends the operation of the telephone, the dynamo machine, and incidental to the dynamo electric machine practically all the gigantic electrical industries of the world, including electric lighting (q.v.), electric traction, the operation of electric motors for power purposes,

and electro-plating (q.v.), electrotyping (q.v.), etc.

In his investigations of the peculiar manner in which iron filings arrange themselves on a cardboard or glass in proximity to the poles of a magnet, Faraday conceived the idea of magnetic "lines of force" extending from pole to pole of the magnet and along which the filings tend to place themselves. On the discovery being made that magnetic effects accompany the passage of an electric current in a wire, it was also assumed that similar magnetic lines of force whirled around the wire. For convenience and to account for induced electricity it was then assumed that when these lines of force are "cut" by a wire in passing across them or when the lines of force in rising and falling cut the wire, a current of electricity is developed, or to be more exact, an electromotive force is developed in the wire that sets up a current in a closed circuit.

Faraday advanced what has been termed the molecular theory of electricity which assumes that electricity is the manifestation of a peculiar condition of the molecule of the body rubbed or the ether surrounding the body. Faraday also, by experiment, discovered paramagnetism and diamagnetism, namely, that all solids and liquids are either attracted or repelled by a magnet. For example, iron, nickel, cobalt, manganese, chromium, etc., are paramagnetic (attracted by magnetism), whilst other substances, such as bismuth, phosphorus, antimony, zinc, etc., are repelled by magnetism or are diamagnetic ('Phil. Trans.,' 1845). Brugans of Leyden in 1778 and Le Baillif and Becquerel in 1827 had previously discovered diamagnetism in the case of bismuth and antimony. Faraday also rediscovered specific inductive capacity in 1837, the results of the experiments by Cavendish not having been published at that time. He also predicted (*Phil. Mag.*, March 1854) the retardation of signals on long submarine cables due to the inductive effect of the insulation of the cable, in other words, the static capacity of the cable.

The 25 years immediately following Faraday's discoveries of electric induction were fruitful in the promulgation of laws and facts relating to induced currents and to magnetism. In 1834 Lenz and Jacobi independently demonstrated the now familiar fact that the currents induced in a coil are proportional to the number of turns in the coil. Lenz also announced at that time the important law that, *in all cases of electromagnetic induction the induced currents have such a direction that their reaction tends to stop the motion that produces them*, a law that was perhaps deducible from Faraday's explanation of Arago's rotations.

In 1845 Joseph Henry, the American physicist, published an account of his valuable and interesting experiments with induced currents of a high order, showing that currents could be induced from the secondary of an induction coil to the primary of a second coil, thence to its secondary wire, and so on to the primary of a third coil, etc. (*Philosophical Magazine*, 1849). Abria published the results of some researches into the laws of these induced currents, but owing to their complexity the investigation was not productive of very notable results. ('Ann. de Chimie III,' i, 385). About 1850

Kirchoff published his laws relating to branched or divided circuits. He also showed mathematically that according to the then prevailing electrodynamic theory, electricity would be propagated along a perfectly conducting wire with the velocity of light. Helmholtz investigated mathematically the effects of induction upon the strength of a current and deduced therefrom equations, which experiment confirmed, showing amongst other important points the retarding effect of self-induction under certain conditions of the circuit ('Poggendorf Ann.' 1851). In 1853 Sir William Thomson (later Lord Kelvin) (q.v.) predicted as a result of mathematical calculations the oscillatory nature of the electric discharge of a condenser circuit. To Henry, however, belongs the credit of discerning as a result of his experiments in 1842 the oscillatory nature of the Leyden jar discharge. He wrote ('Proc. Am. Phil. Soc.,' Vol. II, pp. 193, 196): *The phenomena require us to admit the existence of a principal discharge in one direction, and then several reflex actions backward and forward, each more feeble than the preceding, until the equilibrium is obtained.* These oscillations were subsequently observed by Feddersen (1857) who using a rotating concave mirror projected an image of the electric spark upon a sensitive plate, thereby obtaining a photograph of the spark which plainly indicated the alternating nature of the discharge. Sir William Thomson was also the discoverer of the electric convection of heat (the "Thomson" effect). He designed for electrical measurements of precision his quadrant and absolute electrometers. The reflecting galvanometer and siphon recorder, as applied to submarine cable signaling, are also due to him.

About 1876 Prof. H. A. Rowland of Baltimore demonstrated the important fact that a static charge carried around produces the same magnetic effects as an electric current. The importance of this discovery consists in that it may afford a plausible theory of magnetism, namely, that magnetism may be the result of directed motion of rows of molecules carrying static charges.

After Faraday's discovery that electric currents could be developed in a wire by causing it to cut across the lines of force of a magnet, it was to be expected that attempts would be made to construct machines to avail of this fact in the development of voltaic currents. (See ELECTRIC MACHINERY; ELECTRIC DIRECT CURRENT; GENERATORS). The first machine of this kind was due to Pixii, 1832. It consisted of two bobbins of iron wire, opposite which the poles of a horseshoe magnet were caused to rotate. As this produced in the coils of the wire an alternating current, Pixii arranged a commutating device (commutator) that converted the alternating current of the coils or armature into a direct current in the external circuit. This machine was followed by improved forms of magneto-electric machines due to Ritchie, Saxton, Clarke, Stöhrer 1843, Nollet 1849, Shepperd 1856, Van Maldern, Siemens, Wilde and others.

A notable advance in the art of dynamo construction was made by Mr. S. A. Varley in 1866 (consult his British patent of that year) and by Dr. Charles William Siemens and Mr. Charles Wheatstone (consult 'Royal Society Proceedings,' 1867), who independently discovered that when a coil of wire, or armature, of the dynamo

machine is rotated between the poles (or in the "field") of an electromagnet, a weak current is set up in the coil due to residual magnetism in the iron of the electromagnet, and that if the circuit of the armature be connected with the circuit of the electromagnet, the weak current developed in the armature increases the magnetism in the field. This further increases the magnetic lines of force in which the armature rotates, which still further increases the current in the electromagnet, thereby producing a corresponding increase in the field magnetism, and so on, until the maximum electromotive force which the machine is capable of developing is reached. By means of this principle the dynamo machine develops its own magnetic field, thereby much increasing its efficiency and economical operation. Not by any means, however, was the dynamo electric machine perfected at the time mentioned. In 1860 an important improvement had been made by Dr. Antonio Pacinotti of Pisa who devised the first electric machine with a ring armature. This machine was first used as an electric motor, but afterward as a generator of electricity. The discovery of the principle of the reversibility of the dynamo electric machine (variously attributed to Walen 1860; Pacinotti 1864; Fontaine, Gramme 1873; Deprez 1881, and others) whereby it may be used as an electric motor or as a generator of electricity has been termed one of the greatest discoveries of the 19th century. In 1872 the drum armature was devised by Heffner-Altneck. This machine in a modified form was subsequently known as the Siemens dynamo. These machines were presently followed by the Schuckert, Gulcher, Fein, Brush, Hochhausen, Edison and the dynamo machines of numerous other inventors.

In the early days of dynamo machine construction the machines were mainly arranged as direct current generators, and perhaps the most important application of such machines at that time was in electro-plating, for which purpose machines of low voltage and large current strength were employed. (See ELECTRIC DIRECT CURRENT). Beginning about 1887 alternating current generators came into extensive operation and the commercial development of the transformer, by means of which currents of low voltage and high current strength are transformed to currents of high voltage and low current strength, and vice-versa, in time revolutionized the transmission of electric power to long distances. Likewise the introduction of the rotary converter (in connection with the "step-down" transformer) which converts alternating currents into direct currents (and vice-versa) has effected large economies in the operation of electric power systems. See ELECTRIC ALTERNATING CURRENT MACHINERY.

Before the introduction of dynamo electric machines, voltaic, or primary, batteries were extensively used for electro-plating and in telegraphy. There are two distinct types of voltaic cells, namely, the "open" and the "closed," or "constant," type. The open type in brief is that type which operated on closed circuit becomes, after a short time, polarized; that is, gases are liberated in the cell which settle on the negative plate and establish a resistance that reduces the current strength. After a brief interval of open circuit these gases are eliminated or absorbed and the cell is again ready for operation. Closed circuit cells are those in which the gases

in the cells are absorbed as quickly as liberated and hence the output of the cell is practically uniform. The Leclanché and Daniell cells, respectively, are familiar examples of the "open" and "closed" type of voltaic cell. The "open" cells are used very extensively at present, especially in the dry cell form, and in annunciator and other open circuit signal systems. Batteries of the Daniell or "gravity" type were employed almost generally in the United States and Canada as the source of electromotive force in telegraphy before the dynamo machine became available, and still are largely used for this service or as "local" cells. Batteries of the "gravity" and the Edison-Lalande types are still much used in "closed circuit" systems.

The possibility of obtaining the electric current in large quantities, and economically, by means of dynamo electric machines gave impetus to the development of incandescent and arc lighting. Until these machines had attained a commercial basis voltaic batteries were the only available source of current for electric lighting and power. The cost of these batteries, however, and the difficulties of maintaining them in reliable operation were prohibitory of their use for practical lighting purposes. The date of the employment of arc and incandescent lamps may be set at about 1877. Even in 1880, however, but little headway had been made toward the general use of these illuminants; the rapid subsequent growth of this industry is a matter of general knowledge. (See ELECTRIC LIGHTING). The employment of storage batteries (q.v.), which were originally termed secondary batteries or accumulators, began about 1879. Such batteries are now utilized on a large scale as auxiliaries to the dynamo machine in electric power-houses and substations, in electric automobiles and in immense numbers in automobile ignition and starting systems, also in fire alarm telegraphy and other signal systems.

In 1871 the electric telegraph had grown to large proportions and was in use in every civilized country in the world, its lines forming a network in all directions over the surface of the land. The system most generally in use was the electromagnetic telegraph due to S. F. B. Morse of New York, or modifications of his system. (See TELEGRAPH). Submarine cables (see CABLE) connecting the Eastern and Western hemispheres were also in successful operation at that time. When, however, at the present day (1918) one views the vast applications of electricity to electric light, electric railways, electric power and other purposes (all it may be repeated made possible and practicable by the perfection of the dynamo machine), it is difficult to believe that no longer ago than 1871 the author of a book published in that year, in referring to the state of the art of applied electricity at that time, could have truthfully written: "The most important and remarkable of the uses which have been made of electricity consists in its application to telegraph purposes" (Miller's 'Magnetism and Electricity,' p. 460). The statement was, however, quite accurate and perhaps the time could have been carried forward to the year 1876 without material modification of the remarks. In that year the telephone (q.v.), due to Alexander Graham Bell (q.v.), was invented, but

it was not until several years thereafter that its commercial employment began in earnest. Since that time also the sister branches of electricity just mentioned have advanced and are advancing with such gigantic strides in every direction that it is difficult to place a limit upon their progress. For a more adequate account of the use of electricity in the arts and industries see ELECTRICAL MANUFACTURING INDUSTRY.

In 1864 James Clerk Maxwell of Edinburgh announced his electromagnetic theory of light, which was perhaps the greatest single step in the world's knowledge of electricity. (Consult Maxwell's 'Electricity and Magnetism,' Vol. II, Chap. xx). As already noted herein Faraday, and before him, Ampère and others, had inklings that the luminiferous ether of space was also the medium for electric action. It was known by calculation and experiment that the velocity of electricity was approximately 186,000 miles per second; that is, equal to the velocity of light, which in itself suggests the idea of a relationship between electricity and "light." A number of the earlier philosophers or mathematicians, as Maxwell terms them, of the 19th century, held the view that electromagnetic phenomena were explainable by action at a distance. Maxwell, following Faraday, contended that the seat of the phenomena was in the medium. The methods of the mathematicians in arriving at their results were synthetical while Faraday's methods were analytical. Faraday in his mind's eye saw lines of force traversing all space where the mathematicians saw centres of force attracting at a distance. Faraday sought the seat of the phenomena in real actions going on in the medium; they were satisfied that they had found it in a power of action at a distance on the electric fluids (Maxwell's 'Electricity and Magnetism,' preface).

Both of these methods, as Maxwell points out, had succeeded in explaining the propagation of light as an electromagnetic phenomenon while at the same time the fundamental conceptions of what the quantities concerned are, radically differed. The mathematicians assumed that insulators were barriers to electric currents; that, for instance, in a Leyden jar or electric condenser the electricity was accumulated at one plate and that by some occult action at a distance electricity of an opposite kind was attracted to the other plate. Maxwell, looking further than Faraday, reasoned that if light is an electromagnetic phenomenon and is transmissible through dielectrics such as glass, the phenomenon must be in the nature of electromagnetic currents in the dielectrics. He therefore contended that in the charging of a condenser, for instance, the action did not stop at the insulator, but that the "displacement" currents are set up in the insulating medium, which currents continue until the resisting force of the medium equals that of the charging force. In a closed circuit conductor an electric current is also a displacement of electricity. The conductor offers a certain resistance, akin to friction, to the displacement, and heat is developed in the conductor, proportional as already stated herein to the square of the current, which current flows as long as the impelling electric force continues. This resistance may be likened to that met with by a ship as in its progress it displaces the water. The resistance of the dielectric is of a different nature and has been



compared to the compression of multitudes of springs, which, under compression, yield with an increasing back pressure, up to a point where the total back pressure equals the initial pressure. When the initial pressure is withdrawn the energy expended in compressing the "springs" is returned to the circuit, concurrently with the return of the springs to their original condition, this producing a reaction in the opposite direction. Consequently the current due to the displacement of electricity in a conductor may be continuous, while the displacement currents in a dielectric are momentary and, in a circuit or medium which contains but little resistance compared with capacity or inductance reaction, the currents of discharge are of an oscillatory or alternating nature. (See OSCILLATING CURRENT; TELEGRAPHY, WIRELESS). Maxwell extended this view of displacement currents in dielectrics to the ether of free space. Assuming light to be the manifestation of alterations of electric currents in the ether, and vibrating at the rate of light vibrations, these vibrations by induction set up corresponding vibrations in adjoining portions of the ether, and in this way the undulations corresponding to those of light are propagated as an electromagnetic effect in the ether. Maxwell's electromagnetic theory of light obviously involved the existence of electric waves in free space, and his followers set themselves the task of experimentally demonstrating the truth of the theory. This honor was reserved for Prof. H. Hertz, who in 1887 in a series of experiments proved the actual existence of such waves. The discovery of electric waves in space naturally led to the discovery and introduction in the closing years of the 19th century, of wireless telegraphy (q.v.), various systems of which are now in successful use on shipboard, lighthouses and shore and inland stations throughout the world, by means of which intelligence is transmitted across the widest oceans and large parts of continents.

In 1891 notable additions to our knowledge of the phenomena of high frequency and high potential current were contributed by Nikola Tesla (q.v.). (Consult 'Proc. Am. Inst. El. Engrs.,' 1901). Amongst the novel experiments performed by Tesla was to take in his hand a glass tube from which the air had been exhausted, then bringing his body into contact with a wire carrying currents of high potential, the tube was suffused with a pleasing bright glow. Another experiment was to grasp a bulb that was suspended from a single wire attached to a high potential, high frequency current circuit, when a platinum button within the bulb was brought to vivid incandescence, the experimenter at this time standing on an insulating platform. The frequency and potential involved in the experiments made by Tesla at this time were of the order of one or more million cycles and volts. For further information relative to these experiments the reader may be referred to Tesla's 'Experiments with Alternate Currents of High Potential and High Frequency.'

The place of electricity in leading up to the discovery of those beautiful phenomena of the Crookes Tube (due to Sir William Crookes), viz., Cathode rays (consult 'Proc. British Association,' 1879), and later to the discovery of Roentgen or X-rays (q.v.),

must not be overlooked, since without electricity as the excitant of the tube the discovery of the rays might have been postponed indefinitely.

It has been noted herein that Dr. William Gilbert was termed the founder of electrical science. This must, however, be regarded as a comparative statement. Up to the middle of the 19th century, indeed up to about 1870, electrical science was, it may be said, a sealed book to the majority of electrical workers. Prior to this time a number of handbooks had been published on electricity and magnetism, notably Aug. de La Rive's exhaustive 'Treatise on Electricity,' 1851 and (in the French) 1835; Beer's 'Einleitung in die Electrostatik,' Wiedemann's 'Galvanismus,' and Reiss' 'Reibungsal-elektricitat.' But these works consisted in the main in details of experiments with electricity and magnetism, and but little with the laws and facts of those phenomena. About this time Fleeming Jenkin's work on 'Electricity and Magnetism' and Clerk Maxwell's 'Treatise on Electricity and Magnetism' were published. These books were departures from the beaten path. As Jenkin states in the preface to his work the science of the schools was so dissimilar from that of the practical electrician that it was quite impossible to give students sufficient, or even approximately sufficient, textbooks. A student he said might have mastered De la Rive's large and valuable treatise and yet feel as if in an unknown country and listening to an unknown tongue in the company of practical men. As another writer has said, with the coming of Jenkin's and Maxwell's books all impediments in the way of electrical students were removed, "the full meaning of Ohm's law becomes clear; electromotive force, difference of potential, resistance, current, capacity, lines of force, magnetization and chemical affinity were measurable, and could be reasoned about, and calculations could be made about them with as much certainty as calculations in dynamics" (Introduction to 'Electricity in the Service of Man'). Since that time also the real science of electricity has rapidly advanced. Various units of electricity and magnetism have been adopted and named by representatives of the electrical engineering institutes of the world, which units and names have been confirmed and legalized by the governments of the United States and other countries. Thus the Volt, from the Italian Volta, has been adopted as the practical unit of *electromotive force*, the Ohm, from the enunciator of Ohm's law, as the practical unit of *resistance*; the Ampère, after the eminent French scientist of that name, as the practical unit of *current strength*, the Henry as the practical unit of *inductance*, after Joseph Henry and in recognition of his early and important experimental work in mutual induction. See ELECTRICAL UNITS; ELECTRICAL TERMS.

The theories regarding electricity are also undergoing change. Indeed it may with truth be said that the trend of all scientific investigation now leads to the conclusion that matter in its final analysis is electrical in its nature—in fact is electricity; the theory upon which this view is based being termed the electronic theory, or the electric theory of matter. See ELECTRON.

This theory (or better, hypothesis) in a word assumes that the atom of matter, so far

from being indivisible, as assumed under the older theories, is made up of smaller bodies termed electrons, that these electrons are electrical in their nature, and consequently all matter ultimately is electrical, the atoms of the different elements of matter consisting of a certain number of electrons, thus, 700 in the hydrogen atom and 11,200 in the oxygen atom. This theory of matter though of comparatively recent origin in several of its important features is not altogether one of a day, nor is it due to the researches of one man or to the conception of one mind. Thus, as regards the view that the atom is not an indivisible particle of matter, but is made up of numerous electrons, many scientists have for years held that all the elements are modifications of a single hypothetical substance, protyle, "the undifferentiated material of the universe." Nor is the theory entirely new in its assumption that all matter is electrical. Faraday, Weber, Helmholtz, Clifford and others had glimpses of this view; and the experimental work of Zeeman, Goldstein, Crookes, J. J. Thomson and others had greatly strengthened this view. Over 35 years ago Weber predicted that electrical phenomena were due to the existence of electrical atoms, the influence of which on one another depended on their position and relative accelerations and velocities. Helmholtz and others also contended that the existence of electrical atoms followed from Faraday's laws of *electrolysis*, and Johnstone Stoney, to whom is due the term "electron," showed that each chemical ion of the decomposed electrolyte carries a definite and constant quantity of electricity, and inasmuch as these charged ions are separated on the electrodes as neutral substances there must be an instant, however brief, when the charges must be capable of existing separately as electrical atoms; while in 1887, Clifford (q.v.) wrote: "There is great reason to believe that every material atom carries upon it a small electric current, if it does not wholly consist of this current."

Whether the electronic theory will survive or will in turn be displaced by some more suitable theory remains for the future to determine. In the meantime, be that as it may, the practical application of electricity will go on apace. It is an every day saying of laymen that electricity is as yet in its infancy. This remark causes technical men to smile, for "electricity" is already a most prodigious infant. But in the sense that we may only be on the threshold of the possible utilizations of this most wonderful of nature's agents, the remark is perhaps true. Predictions that were with diffidence made in the closing decade of last century to the effect that within 100 years of that time people would probably speak to one another without artificial means of communication; that wires would be laid along every street and tapped into every house as gas pipes were then, for lighting and power purposes, have been for a decade facts accomplished. What the next 20 years shall bring forth with regard to the applications of electricity none can tell. Twenty years ago it would have been difficult to find one steam railroad engineer willing to admit that application of electric traction to steam railroads was a possibility. To-day much has been done in this

direction in the improvement of railroad terminal facilities, and it is now difficult to find one steam railroad engineer who will deny that in 20 years hence all the important steam railroads of this country may not be operated electrically. In other directions the progress of events as to the utilization of electric power may be expected to be equally rapid. In every part of the world the power of falling water, nature's perpetual motion machine, which has been going to waste since the world began, is now being converted into electricity and transmitted by wire hundreds of miles to points where it is usefully and economically employed. (See *ELECTRIC TRANSMISSION OF ENERGY*). But the extensive utilization of falling water will not be limited to natural water falls. In hundreds of places where a fall of 40 to 400 feet extends over 10 to 50 miles, and where in the aggregate hundreds of thousands of horse power, by suitable hydraulic methods, are available, this power will be usefully employed, thereby in large measure conserving the limited quantity of the world's coal. It has for instance been proposed to dam Niagara River at the foot of the gorge whereby another source of water power equal to that at the present falls would be available. The Jehlun River in Kashmir, India, too, has a fall of 2,480 feet in 80 miles with a minimum flow of 30,000 gallons per second, and a beginning has been made to develop the 1,000,000 electric horse power here represented, a considerable portion of which it is proposed to utilize in the production of nitrate of lime for fertilizer purposes, by combining by means of powerful electric currents the limestone that abounds in this region with the nitrogen of the air, a combination which Danish engineers have shown to be commercially possible, and which inexhaustible product may in time be economically available to replenish the failing powers of the farm lands of America and other countries. Within 10 or 20 years also that dream of the electrical engineer, the direct production of electricity from coal without the intervention of the steam engine with its wasteful methods, may be realized. Other means, now unknown, of developing electricity may be wrested from nature's storehouse. Indeed in view of the past progress of electricity, and especially in view of its marvelous progress in the last two decades, theoretically and practically, it requires no great exercise of the imagination to conceive that the time may not be far distant when the universal artificial source of the world's heat, light and power, will be electricity, and that what is now only surmise as to the sameness of electricity and matter will be demonstrated beyond reasonable doubt. Not only will wireless telegraphy be more perfected than at present, but wireless telephony, and "seeing by electricity" to a distance, may all be practically accomplished. Indeed, it is not even beyond the possibilities that the transference of thought directly from brain to brain with the ether as the medium—the suggestion of which is now regarded as the vagary of a disordered imagination—may then also be realized. In short our successors of 25 or 30 years hence may wonder at our obtuseness in not perceiving the obviousness of things which to them may then be self-evident, virtually as we now marvel at the simplicity of our cleverest ancestors in so long

failing to recognize the identity of frictional, animal, and voltaic electricity, or the more simple fact that the wind, by them regarded as a phenomenon, is merely air in motion.

WILLIAM MAVER, JR.,

Author of 'American Telegraphy and Encyclopedia of the Telegraph'; Fellow, American Institute Electrical Engineers.

**ELECTRICITY, Atmospheric.** Experiments have shown that there is always free electricity in the atmosphere, which is sometimes negative and sometimes positive, but most generally positive, and the intensity of this free electricity is greater in the middle of the day than at morning or night and is greater in winter than in summer. In fine weather the potential increases with altitude at the rate, according to some writers, of about 30 volts per foot. To detect the presence of free electricity in the air a pointed metal rod projecting into the air several feet and connected at its lower end to a gold leaf electroscope may be used. When this rod is projected into the air a few feet the leaves diverge. Kites and balloons have also been used to detect and, so to speak, draw down the free electricity of the air. The origin of atmospheric electricity is still unknown. Some physicists have ascribed it to the friction of the air upon the ground, others to the gradual oxidation of plant and animal life, others again to evaporation, to induction from the sun, and to differences of temperature. Most authorities are agreed, however, that whatever may be the origin of free electricity in the atmosphere the electricity of enormous voltages that disrupts the air and produces the phenomena of lightning (q.v.) is due to the condensation of the watery vapor forming the clouds; each minute vapor drop as it moves through the air collecting upon its surface a certain amount of free electricity. Then as these drops of vapor coalesce into larger drops with a corresponding decrease in the total surface exposed the electric potential rises until it overcomes the resisting power of the air. This remark will be more clearly understood when it is considered that with a given charge of electricity its potential rises as the electrical capacity of the object holding the charge is decreased, which is the case when the minute vapor drops coalesce into larger drops. The similarity of lightning to the electricity developed by an electrical machine was demonstrated by Franklin in his memorable kite experiments.

Saint Elmo's fire (q.v.) is another phase of atmospheric electricity to be considered in this connection. It is otherwise known as the fire of Saint Elias, of Saint Clara, of Saint Nicholas and of Helena, as well as composite, composant or corposant (that is, *corpus sancium*). The phenomenon is observed, usually during a thunder storm, at the tops of trees, spires, etc., or on the heads of animals, as a brush or star of light.

**ELECTRICITY, Cause of Death by.** As is well known, one of the most important safeguards of the human body against the passage of electrical currents through it is its high degree of resistance. This degree of resistance, however, is subject to a considerable amount of variation. If the skin is dry the resistance is from 5 to 20 times as great as when

the skin is wet. From what is known of the amount of electrical current necessary to cause death in man, it is probable that 1,600 volts of electromotive force, of a continuous current, is sufficient to bring about this end, and that an alternating current of half this voltage would probably be fatal. In fact, the general deduction has been drawn from the experiments conducted in electrocution work at the Sing Sing prison, that no human body can withstand an alternating current of 1,500 volts, and 300 has produced death, while for the continuous current it may be necessary that over 3,000 volts may be required to bring about fatal results. Some of the minor injuries due to lightning and electricity are severe burns, paralysis of some of the muscles, deafness, loss of smell and taste, hysterical phenomena, traumatic neuroses. Occasionally blindness has resulted, also insanities of the maniacal type have been known to occur, following lightning stroke. As to the cause of death by lightning and electricity, modern research has shown that there are marked changes in the blood vessels of a hæmorrhagic type, and minute alterations in the nerve cells, but these seem to be secondary to the physiological action that the electrical current has upon the fibres of the heart muscle. The electrical shock brings about a condition of delirium or fibrillary contraction of the heart muscle, causing a stoppage of that organ. This theory of the cause of death at present has the largest number of adherents.

As to what can be done for the treatment of electrical shocks, medical science is still somewhat in doubt. For all practical purposes, death, when it takes place, is instantaneous. The evidence derived from non-fatal cases is of great interest. In these, personal experience has shown that a number of individuals who have been rendered unconscious have recognized in the brief moments of consciousness the experience of a strange sensation. Recoveries from the shock of electricity or lightning which have been severe enough to bring about unconsciousness are very common. As to the border lines which separate the recoverable from the fatal cases it seems difficult to determine. Promptness in the treatment is imperative. External heat to the body, artificial respiration and cardiac stimulants should be used simultaneously. It is of importance to remember that the body of a patient in contact with live wires must not be touched by the rescuer with naked hands, but should be dragged away by his clothing, or removed from contact with the earth by slipping a board under him, thus to break the connection with the live wires. Live wires may also be raised by a stick and thus take the body out of the circuit. Artificial respiration (q.v.) by the Sylvester method or by means of the Gibbon's pump should be performed and the body should be surrounded by hot bottles or bricks, and rubbed, and suitable cardiac stimulants should be utilized. Injections of large quantities of hot salt solution into the rectum may be of service and occasionally it may be necessary to infuse normal salt solution directly into the veins. Efforts at artificial respiration should not be discontinued under from three to six hours. Consult Jelliffe, (Peterson and Haynes Textbook of Legal Medicine and Toxicology.)

**ELECTRICITY, Contact Theory of.** a theory which assumes that the electromotive force of a voltaic cell, and perhaps the electricity produced by friction, is due to the difference of potential assumed by two dissimilar substances when placed in contact.

**ELECTRICITY, Diffusion of.** Electricity diffuses itself on the surface of a conductor. This may be proved very easily, by a simple apparatus devised by Faraday. An insulated spherical conductor has two hemispherical cups carefully fitted to it, each attached to an insulating handle. The conductor and its covering are charged with electricity, the cups are then removed and the conductor is brought near an electroscope. No divergence of the leaves occurs, indicating that none of the electricity has passed into the conductor. If the conductor have a spherical shape, the electricity distributes itself equally over the surface; in other words, the density is the same on every part of the surface. We may conceive the electric fluid to surround the conductor as an ocean of uniform depth. If the conductor be a brass disc, the electricity is found in greater quantity at the edges or rim. If it be a brass cylinder with rounded ends, the density is greatest at the ends. If the conductor have the shape of a cone, the density is greatest at the apex, and the sharper the apex the greater the density. Hence the remarkable effect of a pointed body in dissipating an electric charge.

**ELECTRICITY, Dissipation of.** The gradual loss of electricity from a charged body surrounded by non-conductors which takes place by means of them is called dissipation of the electric charge. A charged conductor, for instance, supported on a glass pillar, slowly loses its electricity. This is due partly to the creeping of the electricity along the surface of the glass, which, even if it be free from dust and dirt, is seldom absolutely free from an invisible film of moisture; and partly to the air that surrounds the insulated conductor, the electrified body charging the particles of air with similar electricity and then repelling them, by which means a gradual loss of charge occurs. Experiments extending over a period of several years show that this dissipation of electricity does not take place in a vacuum. Coulomb made a careful investigation into the laws of dissipation, by which he was able to allow for it in cases where he could not arrange his experiments so as to be undisturbed by it. Coulomb was led by his experiments to abandon the use of glass as a support for his conductors whenever it was possible, employing instead thin stems of shellac, and sometimes suspending small electrified bodies by well-dried silk fibres. He found that the amount of loss in a given time by means of the particles of air diminishes as the charge possessed by the conductor gets weaker and weaker, the losses in successive equal intervals of time being in geometrical progression.

**ELECTRICITY, Experimental Researches in,** by Michael Faraday (1839-55). A monumental work in the literature of science; not merely recording the results of experiment in what Tyndall called "a career of discovery unparalleled in the history of pure experimental

science," but enriching the record with thoughts, and clothing it in many passages in a style worthy of exceptional recognition. In devising and executing experiments for passing beyond the limits of existing knowledge, in a field the most difficult ever attempted by research, Faraday showed a genius and achieved a success, marking him as a thinker not less than an observer of the first order. In strength and sureness of imagination, penetrating the secrets of force in nature, and putting the finger of exact demonstration upon them, he was a Shakespeare of research, the story of whose work has a permanent interest. He made electricity, in one of its manifestations, explain magnetism. He showed to demonstration that chemical action is purely electrical, and that to electricity the atoms of matter owe those properties which constitute them elements in nature. In language of lofty prophetic conception he more than suggested that the physical secret of living things, the animal and the plant, is electrical. He particularly dwelt on the amount of electricity forming the charge carried by the oxygen of the air, which is the active agent in combustion and the supporter of life in both animals and plants, and only stopped short of definitely pronouncing vitality electrical. He urged very strongly as a belief, to which no test of experiment could be applied, that gravitation is by electrical agency, and that in fact the last word of discovery and demonstration in physics will show that electricity is the universal agency in nature. And among his far-reaching applications of thought guided by new knowledge was his rejection of the idea of "action at a distance," in the manner of "attraction." If a body is moved, it is not by a mysterious pull, but by a push. The moving force carries it. These ideas outran the power of science to immediately understand and accept. But Maxwell, Hertz and Helmholtz have led the way after Faraday, to the extent that his electrical explanation of light is now fully accepted. Fifteen years after his death, the greatest of his successors in physics, Helmholtz of Berlin, said in a Faraday lecture in London, that the later advances in electrical science had more than confirmed Faraday's conclusions, and that English science had made a mistake in not accepting them as its point of departure for new research. See LIGHT.

**ELECTRICITY, Frictional.** It was an observation made by the Greek philosopher Thales, 600 years before the Christian era, that, when amber was rubbed, it acquired the property of attracting light bodies. The cause of this attractive power was assigned to a principle to which the name of "electricity" was given—derived from the Greek word for amber. When a piece of wax is rubbed on the coatsleeve, an attractive power is awakened in it; it is capable of attracting small pieces of light paper or particles of sawdust. Taking a warm glass tube closed at one end, and rubbing it with silk, the same thing is manifested. It is observed also that after contact with the wax or tube, the light bodies fall away, being seemingly repelled. If a stick of sealing-wax be rubbed with flannel and then balanced on a paper loop suspended by a silk thread and the knuckle be presented to it, the wax will in like manner follow the hand.

We have, therefore, the fact that an electrified body attracts or is attracted by an unelectrified body. Another experiment of a simple character may be mentioned. Take a piece of warm brown paper or sheet of foolscap, place it upon a warm board and rub it well over with a piece of india-rubber,—it clings to the board; or remove it from the board and apply it to the wall of the room, and it adheres to the wall and remains in its position till its electricity is dissipated. Observation of these phenomena led to the development of the electric machine (q.v.).

**ELECTRICITY FROM HEAT.** The deriving of electricity directly from the application of heat is interesting, though it has not proven of commercial value. Two different metals in contact usually show a difference of potential. This difference is most marked in the case of bismuth and antimony. When bars of these metals are soldered together at one end and the opposite ends connected by a copper wire, and a flame is applied to the point of junction a slight electric current is set up, flowing through the closed circuit thus formed. The cooling of the point of junction also sets up a current. An apparatus made on this principle is called a thermo-electric couple, and a series of such couples, arranged to work together, is called a thermopile; a still larger aggregation of thermo-electric couples arranged in rings superimposed has been styled a thermo-electric generator. With any of these contrivances the current obtained is so minute as to serve no purpose except experiment. The thermopile is valued for experimental purposes because of the great constancy obtainable with a very slight current. Iron is not a good metal to use in a thermopile, because at certain temperatures its potential coincides with nearly all other metals, so that there would be no current when that temperature was reached.

Pyroelectricity is not to be confused with thermo-electricity because of the similarity of name. It treats of the phenomena of electric polarity in minerals on being heated or cooled. The quality of pyroelectricity is best shown in tourmaline, a crystal of which on being heated from about 10° to 150° C. displays positive electrification at one end and negative at the other; but on cooling the polarity is reversed and the positive and negative ends change places. Twin crystals of quartz also show the phenomena and other crystals in a lesser degree.

**ELECTRICITY IN MEDICINE.** See ELECTROTHERAPEUTICS.

**ELECTRICITY IN MINING.** See MINES AND MINING.

**ELECTRICS and NON-ELECTRICS.** The chief work of the earliest experimenters in electricity was to divide bodies into electrics, which they could excite by friction, like amber; and non-electrics, such as the metals, which they could not so excite. These names were given to the two classes by Gilbert of Colchester (1600). But Du Fay (1733-45) showed that electrics are identical with non-conductors, and non-electrics with conductors; and that the reason why non-electrics did not exhibit excitement by friction was that the electricity was conducted away from them as fast as it was produced. The distinction was thus broken down.

**ELECTRO-BALLISTIC MACHINES.** See GUNNERY.

**ELECTRO-BIOLOGY**, the science which treats of the electric currents developed in living organisms; also the department of knowledge which treats of the influence or control over the feelings, thoughts and actions of a mesmerized person. Very simple powers of observation show that the motions of a man's body are under the direction of his will. He puts forth his hand because he wills to do so; he walks through volition, even though his mind be occupied with other things; and talks or is silent as his will directs. It follows that there is some method by which the will communicates with the physical mechanism of that wonderful machine, the human body. Through anatomy we learn that the muscles do the work, and that the nerves guide the muscles, and that the nerves all proceed from or centre in the brain. Through chiropractic we learn to plot the paths of the nerves through the body, and discover when their office is interfered with. Through phrenology we learn that certain classes of nerves connect with certain portions of the brain, and thus certain brain areas are identified with certain physical, mental and moral capacities.

But the thing we cannot demonstrate—is because we cannot see it—is just how the will connects with a portion of the brain and sends out its order, which we know travels through the nerves to the muscles. Therefore we have to theorize as to how this is done, and the best theory appears to be the electric or magnetic theory, that that which Mesmer called "animal magnetism" is the medium of exchange. This is not meant as an endorsement of all that Mesmer said and did—far from it—but simply that the force, process or thing used and little understood by Mesmer is the same force, process or thing that translates a man's will into brain action. The problem is elucidated by a study of hypnotism and mediumistic control. It will be remembered that mesmerism and hypnotism have been identified as based on the same natural laws, and that all authorities on the subject are in agreement that in hypnotism one person's will is replaced by another person's. The subject (or victim) of a hypnotist surrenders his will to the hypnotist, to the degree in which he is brought under the influence of hypnosis. This is why the subject obeys the commands of the hypnotist, even when told to do ridiculous and absurd things. The hypnotist has got control of the subject's "magnetism" for the time being, and he is helpless, a mere puppet or slave of his hypnotist's will. This is logical and rational, and for a fuller exposition of the subject the reader is referred to the article on HYPNOTISM. Mesmer apparently was right in his assumption that by mesmeric passes he gained control of his patient's magnetism. His theory was that there existed "a fluid universally diffused, continuous, and naturally susceptible of receiving, propagating and communicating all motor disturbances." (Binet and Fere, 'Animal Magnetism,' p. 5.) This is exactly the sort of fluid that meets the requirements of transmitting one's will to one's brain and nerves; but to-day we do not use the word "fluid," rather "ether" to express the medium

through which electricity, magnetism, X-rays and similar manifestations are believed to travel. Mesmer considered that the human body was charged with this magnetism much as the earth is charged with electricity, and the theory stands analysis. He called it "animal magnetism," which is here used as the most familiar term, though it might better be termed "physical magnetism." That animals have it as well as humans is shown by the fact that animals can be hypnotized. Away back in 1646 Father Athanasius Kirchner described his hypnotizing of poultry, and later this became a fashionable pastime in France. In 1872 Czermak repeated his experiments, and also hypnotized birds, rabbits, salamanders and crabs.

Whether this animal magnetism is identical with animal electricity, or whether — as is more probable — it is a separate form of some higher etheric vibration than electricity, is interesting, but not all-important, and appears never to have been demonstrated. The vital fact of interest in electro-biology is that the human organism is virtually a vitalized dynamo, that gathers charge from the air breathed, and which gives off energy through the muscles under the direction of the will. Electrical engineers commonly make this comparison, being struck with the similarity of the human organism with the electric dynamo. And the fact that the human organism gets its charge of magnetism through the air breathed suggests that human magnetism is either universal in space or at least existent in both the air and water in which men and fishes live.

Another proof of the reality of this thing we call "animal magnetism" is furnished by spiritualistic or mediumistic phenomena. The "animal magnetism" is believed to be the cause of the "aura," of which every student has read, but which few have seen. Spiritualistic mediums often speak of witnessing an individual's aura, but this evidence will satisfy only those who believe in mediumship. To actually see the aura or evidence of human magnetism this experiment is suggested: Arrange a perfectly black background and place a large, strong man about five feet in front of it, at dusk or twilight. Take a position 20 to 40 feet away, and gaze steadily on the scarcely visible form of the man. When the conditions and distances are right anyone of good sight will see a faint radiance or aura emanating from and outlining the man on the black background. It is claimed that the more moral the man the brighter the aura, and that this is why the old masters painted auras about the heads of pictures of saints and especially of Jesus Christ. Another evidence of the reality of this magnetism comes from the spiritualistic mediums. They claim that the work of mediumship is extremely exhausting, and deprives them of their magnetism, and that this is why they cannot give genuine exhibitions ad libitum as visitors may demand. And many who have investigated mediumship are convinced that this is so.

The term electro-biology was coined about 1850 to describe the relationship between electricity and life. We do not know what electricity is, and we do not know what life is; we have to judge of both by their manifestations. We know little of the nature and nothing

of the origin of either, although some scientific men and some theologians are apt to be dogmatic in asserting that this or that must be or cannot be possible. But we do know that through some medium the will controls man's sensory organism and physical functions, and we choose to call this thing "animal magnetism," as Mesmer called it, and to consider it of the nature of electricity. Reasoning analogously, that as the wireless telegraph conveys a certain vibration which may be picked up by an instrument hundreds of miles away through etheric vibrations, caught by a coherer or detector, so we conclude that the will also originates vibrations, which many call thought-vibrations, and sends them through the etheric magnetism that imbues all men and animals, and perhaps all nature. But ordinarily these vibrations are picked up and responded to only by the organism of the man who sends them out, presumably because his magnetic vibrations harmonize with his physical body. It is also logical to reason that this sort of magnetism exists everywhere, as we suppose electricity pervades the universe, and that the phenomena of telepathy or thought-transference, and mind-reading, are explainable through harmonic vibrations of the ether which this magnetism permeates and pervades. Clairvoyance and clairaudience likely are closely related, so that in solving the problem of physical magnetism probably these will also be solved.

It is stated in 'The Great Psychological Crime' (p. 178) that "animal magnetism is an important factor in the development of mediumship," and that "the room in which the sittings are held must become thoroughly magnetized with the animal magnetism of the controlling intelligences." The reader who cares to pursue the subject further should consult this book.

CHARLES H. COCHRANE.

**ELECTRO-BRONZE.** See ELECTROPLATING.

**ELECTROCHEMICAL EQUIVALENTS.** The general principles of electrochemistry (q.v.) and especially Faraday's laws (q.v.) have shown us a definite quantitative relation between the amount of electricity passing in a given electrolysis, and the amount of decomposition resulting. According to Faraday's laws, the amount of any given element which will be deposited by a given amount of current is directly proportional to the amount of current passing, and to the chemically equivalent weight of the element in question. Quantitatively, it requires 96,500 coulombs of electricity (ampere-seconds) to deposit a chemically equivalent weight of any substance; or, to put it in a more practical way, it requires 96,500 coulombs to make a unit change of valence of a gram-atom of any substance. From this numerical relation one can then calculate the weight of any element that will be deposited by a unit amount of current in a unit time. This is called the Electrochemical Equivalent of the element. For scientific purposes it is usually stated in grams per coulomb or per ampere-hour; for commercial use larger units are convenient, such as kilograms or pounds per ampere-day, or per 1,000 ampere-hours.

Following is a table of the electrochemical equivalents of the more common elements.

1	2	3	4	5
Element	Symbol	Atomic weight	Valence	Grams per ampere-hour
Aluminium.....	Al	27.1	3	0.33702
Antimony.....	Sb	120.2	3	1.4948
			5	0.89689
Arsenic.....	As	74.96	3	0.93221
			5	0.55932
Barium.....	Ba	137.37	2	2.5625
Bismuth.....	Bi	208.0	3	2.5867
			5	1.5520
Bromine.....	Br	79.92	1	2.9817
Cadmium.....	Cd	112.40	2	2.0976
Calcium.....	Ca	40.07	2	0.74747
Chlorine.....	Cl	35.46	1	1.3229
Chromium.....	Cr	52.0	2	0.97001
			3	0.64667
Cobalt.....	Co	58.97	2	1.1000
			3	0.73335
Copper.....	Cu	63.57	1	2.3717
			2	1.1858
Fluorine.....	F	19.0	1	0.70885
Gold.....	Au	197.2	1	7.3572
			3	2.4524
Hydrogen.....	H	1.008	1	0.0376066
Iodine.....	I	126.92	1	4.7351
Iron.....	Fe	55.84	2	1.0416
			3	0.69443
Lead.....	Pb	207.20	2	3.8651
			4	1.9326
Lithium.....	Li	6.94	1	0.25892
Magnesium.....	Mg	24.32	2	0.45367
Manganese.....	Mn	54.93	2	1.0247
Mercury.....	Hg	200.6	2	3.7420
Molybdenum.....	Mo	96.0	3	1.1939
Nickel.....	Ni	58.68	2	1.0946
			3	0.72975
Nitrogen.....	N	14.01	3	0.17423
			5	0.10454
Oxygen.....	O	16.00	2	0.29847
			4	0.14923
Phosphorus.....	P	31.04	3	0.38601
			5	0.23161
Platinum.....	Pt	195.2	4	1.8206
Potassium.....	K	39.10	1	1.4588
Selenium.....	Se	79.2	4	0.73870
Silicon.....	Si	28.3	4	0.26395
Silver.....	Ag	107.88	1	4.02480
Sodium.....	Na	23.00	1	0.85809
Strontium.....	Sr	87.63	2	1.6347
Sulphur.....	S	32.06	4	0.29903
Tellurium.....	Te	127.5	2	2.3784
			4	1.1892
			6	0.79280
Tin.....	Sn	118.7	2	2.2142
			4	1.1071
Titanium.....	Ti	48.1	4	0.44863
Tungsten.....	W	184.0	6	1.1441
Uranium.....	U	238.2	6	1.4811
Vanadium.....	V	51.0	5	0.38054
Zinc.....	Zn	65.37	2	1.2194

These values are taken from 'Electrochemical Equivalents' by Hering and Getman (New York 1917).

G. A. ROUSH,  
Assistant Secretary, American Electrochemical Society.

### ELECTROCHEMICAL INDUSTRIES.

Electrochemistry may be defined as that branch of chemistry relating to the carrying out of chemical reactions by the means of or with the assistance of electricity. The word electrochemical as here used includes the processes of electrometallurgy, the production and treatment of metals by means of electricity, there being no generic term covering both subjects.

The production or furtherance of chemical action by means of electrical energy may be secured in three ways: (1) By electrolysis—the action of an electric current upon a chemical compound in solution or in a fused condition; (2) by electrothermal action—the production of chemical changes by electrically generated heat; (3) by the discharge of electricity through gases.

The largest employment of electrolysis is in the production and refinement of metals, particularly aluminum and copper; but it is also used extensively in the preparation of a large number of chemical compounds of widely varying character.

In most cases a substance obtained by electrolysis may be prepared also by a strictly chemical process. The choice of methods then becomes simply one of cost. An example in point is the manufacture of metallic sodium; originally discovered by the electrolysis of caustic soda, it was for many years made commercially by the reduction of sodium carbonate with carbon, or of caustic soda by a mixture of iron and carbon; more recently the electrolytic process has replaced the chemical methods, because it is cheaper. In other cases certain products of electrochemical action have not yet been made by any other process.

A great saving of heat is found in most electrothermal processes, due to the fact that the electrically generated heat is applied inside the container, where it is effectively employed, no heat being wasted in heating the contents through the walls of the container, as in combustion processes. But even when produced by the cheapest water power, electric heat costs several times more than heat produced by the combustion of coal, so that where large quantities of heat are needed at only moderate temperatures, the combustion processes are usually cheaper.

We shall here consider the chief electrochemical industries that have thus far attained commercial importance.

**Copper.**—The process of refining copper electrolytically consists in the transfer of copper from the anode to the cathode, by the selective action of the electric current, and in leaving the impurities behind dissolved in the electrolyte, or in the form of slime or sediment. The material at present subjected to profitable electrolyte refining is crude copper containing from 96 to 98 per cent pure copper, and varying amounts of silver, gold, platinum, palladium, nickel, iron, arsenic, antimony, sulphur, etc. This crude copper is obtained from various copper ores by smelting and is cast in copper molds into anode plates, which are about three feet square and one to two inches thick, weighing 250 to 500 pounds. The cathode plates are of electrolytically refined copper, practically the same in length and width as the anodes, but only 1/32 to 1/16 inch thick. The electrolyte, or bath, in which the plates are suspended, is a solution of copper sulphate just short of saturation, with enough sulphuric acid to prevent the separation of hydrated cupric oxide, but not enough to cause hydrogen instead of copper to be separated at the cathode; the proportions are about 3-4 per cent of copper as sulphate and 10-13 per cent of free sulphuric acid. When silver is present in the anode a little salt or hydrochloric acid is added to the electrolyte. The bath is kept at a temperature of about 40-60° C. (100-140° F.). The containing tanks are of wood, usually lined with sheet lead or carefully coated with a pitch compound, and of such dimensions that a distance of from 1.5 to 2 inches exists between the faces of the plates. In some cases the plates are arranged in series and in others in parallel or multiple. In the series system the anodes,

which are much smaller than in the multiple system, are suspended in the electrolyte from one-half to three-fourths of an inch apart, and only the end ones in the series are connected with the poles of the generator. With this arrangement the copper dissolved from the inner face of the first anode is deposited on the nearer face of the second plate; the farther face of the second plate is dissolved and deposited on the nearer face of the third plate—and so on throughout the series. When the anodes are nearly exhausted the pure copper deposits are removed from the tank and the undissolved remnants of anode stripped from the back of the cathodes.

The series arrangement has the advantage of requiring electrical connections to be made at the first and last plates only, whereas the parallel system requires a connection at every plate; but in the series system the leakage of current due to the short-circuiting action of the sediment and sides of the tank is from 10 to 20 per cent, so that the parallel system is more generally used. The connections between the various plates and the circuit in the parallel systems are made by copper rods, which are run at two different levels along the edges of the tanks, one bar for each set of plates. In some instances these rods are of the inverted V shape, so that the edges will cut through any corrosion which may happen to form at the points of contact. The vats are arranged, with respect to each other, so that each is accessible from all sides and free circulation of the electrolyte is possible. This circulation is sometimes obtained by blowing a stream of air through the electrolyte, but more frequently by arranging the vats in steps, and piping so that the electrolyte may pass from the top of one vat to the bottom of the next, by the action of gravity. This maintains a uniform density of electrolyte, which is necessary for the proper formation of the deposit. The electromotive force required is from 0.2 to 0.4 volt per tank, with a current density of 15 to 20 amperes per square foot of cathode plate surface. The individual vats are connected in series so that the total voltage may be approximately the same as that which the generator furnishes, being usually 110 volts. One ampere of current deposits on the cathode only about one ounce of refined copper in 24 hours, and the current density must be kept below 40 amperes per square foot to avoid mushrooming and consequent short-circuiting. In practice from 400 to 500 ampere-hours are required per pound of copper deposited, the theoretical amount according to Faraday's law being only 386.2 ampere-hours. The loss varies from 4 to 20 per cent according to the system employed.

The main product of refining is commercial cathodes, which are sometimes shipped to consumers, but more frequently cast into wire-bars, ingots, cakes or slabs of standard dimensions and weight. They usually assay from 99.86 to 99.94 per cent pure copper. The yield in commercial cathodes is from 97 to 99 per cent of the anodes treated, excluding the anode scrap which varies in weight from 7 to 15 per cent of the original anode in parallel plants, but this scrap is not a loss as it is collected and recast into anode plates. Besides electrolytic copper most plants secure gold, silver, platinum

and palladium from the slimes, and sometimes selenium, tellurium and other rarer metals. Nickel salts are usually recovered from the solutions.

There are in the United States 10 electrolytic copper refineries with a total capacity of 2,780,000,000 pounds per year; one refinery in Canada with a capacity of 14,000,000 pounds per year. The actual production in 1917 was about 2,300,000,000 pounds, representing approximately 74 per cent of the entire world's production of copper for the year. Or, deducting from the total production the amount that does not require refining, about 275,000,000 pounds from Michigan, the United States production amounts to over 81 per cent of the total production of refined copper. The other 19 per cent is produced in a number of plants of comparatively small capacity in England, Wales and Continental Europe.

**Aluminum.**—Practically the whole output of this metal for the entire world is now produced electrolytically. The only process used on a large scale is that invented independently in 1886 by Charles M. Hall in the United States and by Paul L. T. Héroult in France. This process consists in electrolyzing alumina dissolved in a fused bath of cryolite. The alumina is obtained from the mineral bauxite which occurs abundantly in Arkansas, Georgia, Alabama and Tennessee. The natural material, being a hydrated alumina containing silica, iron and titanium, must be treated in order to drive off the water and eliminate the impurities. This is accomplished by a chemical process. In practice it requires about two pounds of alumina for each pound of aluminum produced. The flux or bath in which the alumina is dissolved consists of cryolite, a natural double fluoride of aluminum and sodium ( $\text{AlF}_3 \cdot 6\text{NaF}$ ) found in Greenland. This is melted in a large carbon-lined, sheet-iron tank which constitutes the negative electrode, a group of suspended carbon rods forming the positive electrode. A current of several thousand amperes at six to seven volts is used. Only a portion of this voltage is required to decompose the alumina, the balance amounting to about four to five volts represents the heat required to keep the bath melted. The passage of the current causes the aluminum to deposit on the bottom of the tank as a fused metal, whence it is drawn off periodically. The oxygen set free combines with the carbon of the positive electrodes and passes off as carbonic oxide. The reaction is  $\text{Al}_2\text{O}_3 + 3\text{C} = 2\text{Al} + 3\text{CO}$ . About one pound of carbon is consumed for one pound of aluminum produced. An excess of alumina is kept floating on the bath so that it is saturated at all times. According to Faraday's law the weight of aluminum deposited by 1,000 amperes is 0.745 pound per hour. The actual yield of metal by the Hall process is about 85 per cent of this theoretical amount. The metal when drawn from the tanks is cast into rough ingots which are afterward remelted and converted into commercial shapes, such as sheets, rods, wires, etc. The United States in 1917 produced about 180,000,000 pounds of aluminum, which was about two-thirds the total production of the world. Before the European War the share of the United States in the total production was under 50 per cent.



## ELECTRO-CHEMICAL INDUSTRY

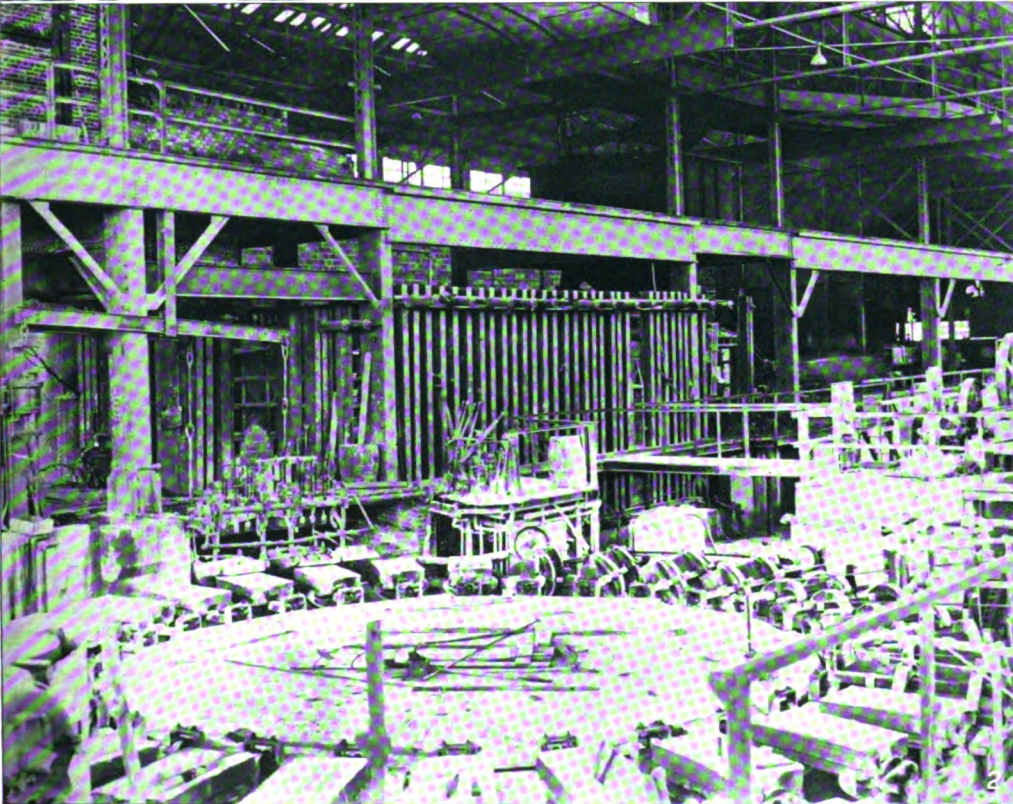
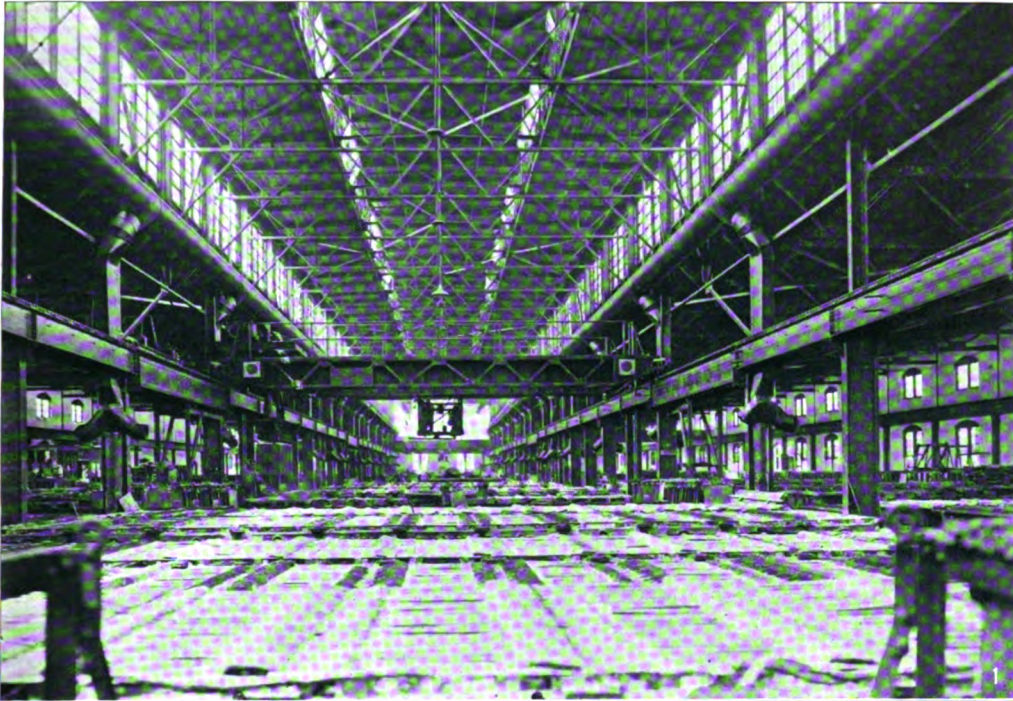

1 Electrolytic process of copper-refining, showing tanks filled with a solution of copper sulphate and containing sheets of copper connected to the terminals of a generator  
2 Casting side of a furnace showing copper anodes placed radially on a Clark casting machine



**Zinc.**—The very high temperature (1300° C. or 2370° F.) necessary to reduce zinc from its common ores, and its generation as a vapor, due to its boiling point being at 930° C. (1700° F.) present difficulties which offer an unusually open field for success to an electrolytic method of reduction. Several processes are in use. They all provide for the preliminary roasting of the ore—which is essentially lead sulphide, zinc sulphide and gangue—at a low red heat, so as to convert the sulphides into oxides and sulphates. The roasted ore is then treated with dilute sulphuric acid, the zinc being dissolved as sulphate, leaving the lead sulphate as an insoluble residue to be smelted by the usual dry methods. Most of the silver present remains with the lead, a small portion passing into solution with the zinc. It is in fact the recovered silver that sometimes makes the process profitable. It is necessary to free the zinc solution from iron, copper and other foreign metals—a matter of considerable difficulty. When sufficiently purified, the zinc sulphate is electrolyzed, the anodes being of lead, and the cathodes thin sheets of zinc. The operation is in reality a reduction of the sulphate, in no sense a refining process. As the reduction proceeds the electrolyte becomes more and more acid, and when hydrogen in quantity is evolved at the cathodes, the electrolyte is run off, and used again to leach roasted ore.

**Lead.**—The electrolytic refining of lead has never been as widely applied as in the case of copper, due to the fact that the operation is more expensive in comparison with the low price of the metal, and that the ordinary furnace-refined lead of commerce is 99.98 per cent pure. In some cases, however, the lead carries valuable impurities that are not readily recovered by furnace methods, and the process of electrolytic refining is resorted to. The principles involved are the same as for copper, the impure lead being used as anode in a solution of lead fluosilicate as electrolyte. The cathode is a rolled sheet of pure lead. The electrolyte ordinarily carries 60 to 70 grams of lead per litre, as fluosilicate, and 80 grams of free hydrofluosilicic acid. Lead normally tends to give a fine crystalline deposit, but by the addition of 0.1 per cent of gelatin to the electrolyte, this is changed to a smooth, coherent deposit. The temperature has no effect on the deposit, but the current used is sufficient to maintain the bath at about 30° C. (86° F.). The current density used is 12–16 amperes per square foot, and the voltage per tank is 0.30–0.38. Tanks are arranged in series with the electrodes in each tank in multiple. The purity of the refined lead is about 99.995 per cent.

**Silver.**—The parting of the gold and silver when the silver is in excess, or the refining of auriferous silver, is also carried on by an electrochemical process. In this process the electrodes are arranged horizontally, the anodes above and separated from the cathode by a porous diaphragm. The cathode is a thin sheet of silver formed into an endless belt which travels horizontally below the series of anodes. The upper surface of the belt is smeared with graphite to prevent a close adherence of the crystals of deposited silver. These crystals are brushed off at the end of the tank upon a conveyor-belt and removed at once from the electrolyte. Another modification has a horizon-

tal graphite plate for cathode, from which the silver crystals are removed by hand with a scraper. The electrolyte carries 1 to 3 per cent of silver, 4 to 6 per cent of copper, and one-tenth of 1 per cent of free nitric acid. A certain amount of the acid is consumed in dissolving the copper present in the silver—about one and one-half pounds to each 1,000 ounces of silver treated.

**Gold.**—The electrolytic process has been used in the recovery of gold from its solution in potassium cyanide, after cyanide extraction. The cyanide liquor is electrolyzed between iron anodes and sheet lead cathodes, using low current density. Chemical precipitation of the gold, using zinc or aluminum is usually preferred, however. In addition to this recovery process, electrolytic refining is practised to a considerable extent. The crude gold is used as the anode, in a solution of gold chloride with hydrochloric acid as the electrolyte. The cathode is a thin sheet of pure gold. A current density of 90 amperes per square foot at a low voltage (say 1 volt) is employed. The gold is deposited in crystalline form, leaving the impurities in the anode as a sludge, or dissolved in the electrolyte.

**Antimony.**—Antimony has been produced by an electrochemical process, but never on any extended scale. One process consists in leaching the sulphide ore with sodium sulphide, and extracting the dissolved antimony from the solution by electrolysis, using iron cathodes, from which the deposited metal is broken by hammering when it reaches a thickness of about one-tenth of an inch. The electrolyzing cell is separated into two compartments by a porous diaphragm, the anode being carbon in a solution of sodium chloride. The chlorine from the anode compartment is used in the manufacture of bleaching powder, and the exhausted sodium sulphide from the cathode compartment is used to leach more ore. One method of working up the slimes from the electrolytic lead-refining process gives a sodium sulphide solution carrying antimony, which is treated in a similar manner. Attempts have also been made to refine antimony in both sulphide and fluoride solutions.

**Nickel.**—While the electrolytic processes have not proved available for the commercial winning of metallic nickel from its ores, its electrolytic refining is successfully accomplished, though the details of the process employed are guarded as a trade secret. As is well known, electroplating with nickel is simple and easy. When, however, a thicker deposition is attempted, the metal scales off of the cathode in thin flakes which cannot be collected and melted into ingots at a commercial profit. The tendency of any iron and cobalt present in the crude nickel to be deposited on the cathode along with the nickel is a serious drawback—and incidentally compels attention to the fact that electrolytically deposited metal is not necessarily pure. It has been proved by experiment that nickel may be thus deposited in thick plates if the operation is conducted with a hot electrolyte—in the neighborhood of 65° C. (150° F.)—and with a comparatively high current density. Difficulty is experienced under these conditions with the evolution of hydrogen from the cathode, causing pitting of its surface. An indirect method of refining nickel by electro-

lysis consists in the deposition of its principal impurity (say copper), the release of other impurities (say silver and platinum) in the anode sludge, leaving the pure nickel in solution in the electrolyte, from which it is then deposited.

**Calcium.**—The production of metallic calcium by electrolysis may be accomplished economically by using fused calcium chloride as the electrolyte. The principal process used in this country is that of Seward and von Kugelgen. The cell consists of a circular iron box through the bottom of which projects a conical iron cathode, insulated from the box. The anode is a carbon lining, also insulated from the box. Above the cathode at the level of the bath is a water-cooled collecting ring within which the metal collects, it being lighter than the bath. By the time the collecting ring is full of metal the top layer is solidified, and the solid metal is gradually lifted up through the ring by a hook, the freshly collected metal building on underneath as it solidifies, thus making a stick or rod of metal.

**Magnesium.**—Being, like aluminum, reducible with difficulty by ordinary furnace methods, magnesium is prepared almost solely by electrolysis. The raw material used is "carnallite," the double chloride of magnesium and potassium. The operation is carried on in a cylindrical steel box, which is made the cathode by suitable electrical connections. The anode is of carbon, and it is enclosed in a porcelain cylinder open at the bottom and with slotted sides, and having a tube at the top for the escape of the chlorine gas set free at the anode. The charge of carnallite is kept in a fused condition by heat applied externally to the steel box. All oxygen is excluded from the apparatus by the introduction of some other gas (usually nitrogen) into the space above the electrolyte. This is necessary in order to prevent the oxidizing of the metallic magnesium, which rises and floats on the surface of the electrolyte. A tendency of the globules of magnesium to gather a film of oxide sufficient to prevent coalescence is overcome by the addition of fluorspar (calcium fluoride) to the molten mass. While the metal thus obtained is not strictly pure, it is sufficiently so to be available for all commercial purposes.

**Sodium.**—Formerly secured by chemical methods at very high temperatures, the world's supply of sodium is now produced wholly by electrolysis. The operation according to the Castner process is conducted in a cylindrical steel crucible so placed in a flue that the body of it can be heated while the inverted neck, through which the cathode enters from below, remains cool. The electrolyte used is caustic soda. The anode is iron, cylindrical in form, with vertical slits which allow the free flow of the electrolyte: it surrounds the upper end of the cathode, a cylinder of wire gauze hanging between from the collecting chamber above. As the operation proceeds, molten metallic sodium is released at the cathode and rises to float on the surface of the caustic soda, being guided by the wire gauze, which it cannot pass owing to its high surface tension. In the collecting chamber the metal is protected by the hydrogen also set free at the cathode, and is drawn off at intervals through a trap.

The Seward and von Kugelgen process uses an electrolyte of fused sodium chloride, the melting point of which has been reduced by the addition of other salts less readily decomposed by the current.

**Potassium.**—There is little commercial demand for metallic potassium. Its production, however, is entirely practicable by the Castner process described for sodium, using caustic potash as the electrolyte.

**Electroplating and Electrotyping.**—Electroplating is the art of covering a metallic surface with an adherent, electrodeposited coating of the same or some other metal, the form of the original surface being retained. The metal coating may be added purely for decorative purposes, or because of its superior resistance to wear or corrosion. Electrotyping is the art of reproducing the form of an object by electrodeposition of a metal, usually copper, in a cast or molded impression of the original object. For further details of these processes, the reader is referred to the articles under these separate headings.

**Caustic Soda.**—The production of caustic soda (NaOH) and chlorine (Cl) by the electrolysis of a solution of common salt (NaCl) is readily realized experimentally ( $\text{NaCl} + \text{H}_2\text{O} = \text{NaOH} + \text{Cl} + \text{H}$ ), but its successful accomplishment on a commercial basis is difficult because of the secondary reactions which take place, forming a mixed product of caustic, salt, and hypochlorite of soda. These difficulties are avoided by separating the caustic soda that is formed, either by a porous diaphragm, by drawing it off as soon as formed, or by absorbing the sodium deposited in mercury or melted lead.

The most prominent system for the electrolytic production of caustic soda and chlorine from common salt is the Castner-Kellner process. The Castner process employed in this country at Niagara Falls is as follows: The electrolytic tank consists of a slate box, 4 feet long, 4 feet wide and 6 inches deep, the joints being set in rubber cement. Two slate partitions reaching within 1/16 inch of the bottom (under which are grooves) divide the cell into three compartments, each 15 inches by 4 feet, sealed from each other by a layer of mercury covering the bottom of the tank to a considerable depth. The two outside chambers through which the brine is passed are provided with graphite anodes. These compartments are provided with gas-tight covers and exhaust pipes of rubber and lead, to lead the chlorine away. The central compartment has an iron cathode, of 20 upright strips, and is filled with pure water above the mercury. Whenever the specific gravity of the water rises to 1.26, from its absorption of caustic soda, it is drawn off and fresh water supplied. The liberated hydrogen is led from this chamber by means of pipes and used as a fuel for the concentration of the caustic. The tank is pivoted at one end on a knife blade and rests at the other on an eccentric, which raises and lowers that end of the tank about half an inch every minute and causes a circulation of the mercury between the outer and middle compartments. The current passes into the outer chambers, splits up the sodium chloride (common salt, NaCl) into sodium and chlorine (Na and Cl), the latter is liberated at the graphite anodes and passes through the exhaust pipe to the absorption chambers where

it combines with slacked lime to form bleaching powder. The sodium combines with the mercury forming sodium amalgam, which by the rocking of the tank passes to the center chamber, where it serves as the anode, and combines with the water to form caustic soda (NaOH) and hydrogen (H<sub>2</sub>), which appears at the iron cathode. Each of these tanks uses 630 amperes at 4.3 volts. The theoretical voltage required is but 2.3, the remainder being utilized in overcoming the ohmic resistance of the electrolyte and in keeping it warm. The output of this process per horse power per day is 12 pounds of caustic and 30 pounds of bleaching powder for each cell. The product contains from 97 to 99 per cent caustic, 1 to 2 per cent sodium carbonate, 0.3 to 0.8 per cent of sodium chloride, and traces of sodium sulphate and sodium silicate. A number of other processes have been developed for the electrolysis of salt solutions for the production of alkali and chlorine, all based more or less on the same general principles as those utilized in the Castner process.

The Acker process, which was formerly used at Niagara Falls, but which has been discontinued, obtained caustic soda and chlorine using molten lead in place of mercury as a cathode, fused salt instead of brine as the electrolyte, and operated at a temperature of 850° C. (1560° F.). The containing tank was a cast-iron vessel 5 feet long, 2 feet wide and 1 foot deep, the sides above the molten lead being covered with magnesia so that the current must pass from the graphite anodes to the lead which acted as the cathode. At one end of the tank was a small compartment separated from the remainder of the vessel by a partition dipping into the lead to such a depth that nothing but this fused lead can pass from one compartment to the other. In the smaller compartment the lead was subjected to a stream of steam, which decomposed the lead-sodium alloy with the formation of NaOH and hydrogen and at the same time kept the alloy in circulation. At intervals the caustic, which was in a fused state, was drawn off and allowed to solidify, thus avoiding the evaporation of water which is necessary in the Castner-Kellner process. The current employed per vessel in the Acker process was 2100 amperes at from 6 to 7 volts, of which energy 54 per cent is used in chemical action, and the remainder in maintaining the temperature. The output of each was 550 pounds of caustic soda and 450 pounds of chlorine in 24 hours.

**Chlorine.**—All processes making caustic soda from salt at the same time produce chlorine gas at the anode. In some cases this is absorbed in lime for the manufacture of bleaching powder, and in other cases it is compressed and liquefied. The liquid chlorine is shipped in pressure tanks for chemical purposes and for water purification. One of the most striking uses to which it has been put is as one of the poison gases used at the front in trench warfare. Hundreds of tons of gas have been used in a single attack.

**Hypochlorites.**—Another electrochemical industry that is widely distributed throughout the country is the manufacture of hypochlorite for bleaching purposes. For some time the use of hypochlorite as a bleach was confined to large installations where an enormous quantity of bleaching liquor was demanded every day, e.g., in the manufacture of paper pulp. Now hypo-

chlorite plants are installed in small units, producing only a few gallons of bleach a day for use in laundries. The types of cell used in hypochlorite manufacture vary widely, but are all alike in that they must have unattackable electrodes of some kind, usually either graphite or platinum. Many of the different types of cells have a number of electrodes in series, acting as bipolar electrodes. The electrolyte used is a 15 to 16 per cent solution of common salt, NaCl. The efficiency of the operation in practice usually amounts to only about 20 to 25 per cent, but the simplicity and ease of working of the process commend it in spite of its low energy efficiency. The minimum requirement is 1.27 kilowatt hours for the production of 1 kilogram of active chlorine, while actual practice requires 6 to 7 kilowatt hours.

**Potassium Chlorate** is produced electrochemically in considerable quantities, both here and abroad. The Gibbs process, used at Niagara Falls, consists in the electrolysis of potassium chloride solution, using a copper or iron cathode and a platinum anode. The current density is high, being 500 amperes per square foot of anode. Each cell uses about four volts, of which 1.4 is required to convert chloride to chlorate, and the remainder produces the heat that maintains the electrolyte at from 50° to 70° C. (125° to 160° F.), which is necessary for the proper reaction. The whole commercial supply is thus produced. Perchlorates are made by electrolyzing chlorates at low temperatures in the same type of cell.

**Hydrogen and Oxygen.**—One of the most widely distributed of the electrochemical industries, but one that is usually installed in fairly small units, is the electrolysis of water for the production of hydrogen or oxygen, or both. When only one of the gases is required it is often more economical to produce it by some other method, but if both gases are needed, it is better to use an electrochemical method, and often the conditions are such that the single gas can be produced advantageously by the electrochemical method.

Apparatus for the commercial electrolysis of water uses as electrolyte a solution either of sulphuric acid (H<sub>2</sub>SO<sub>4</sub>), or one of the alkalis (NaOH or KOH). With the alkalis the cells are usually constructed of iron, and with the acid, they must be lined with lead, whatever the body of the cell may be. With the alkaline solutions, a concentration of 10 to 25 per cent is used, and with acid, 20 to 30 per cent. The voltage needed to force a current through such a cell is composed of three factors — the voltage of decomposition of the water, the voltage necessary to overcome the resistance of the cell, and the voltage necessary to overcome the resistance of the gas layers on the electrodes, sometimes known as "overvoltage." The sulphuric acid solution has a much better conductivity than the alkaline solutions, but the resistance of the gas films is greater on lead than on iron, so that on the whole, cells using alkaline solutions have a lower working voltage than those using acid. The current efficiency in either case can be made to approach 100 per cent.

The total voltage required for the cells is 2.3 to 3.6 volts. The energy requirement for one cubic meter of mixed gases is 3.7 to 5.9 kilowatt hours, the alkaline cells giving the lower figure,

and the acid cells the higher. In the acid cells, lead anodes are used, which peroxidize, and the presence of  $\text{PbO}_2$  causes the oxygen to contain some ozone. The chlorides in the alkaline solution allow the anodes, usually of iron or nickel, to be slowly attacked, requiring occasional replacement. The purity of the gases is usually 97 to 99 per cent.

**Electric Smelting.**—One of the earliest commercial processes in electrochemistry was that devised by E. H. and A. H. Cowles in 1884. A mixture of about two parts of alumina, one or two parts of granulated copper and one or two parts of carbon was introduced in a brick-work chamber. Bundles of carbon rods inserted at the ends formed the electrodes between which a current of 3,000 amperes at 50 volts was maintained. At a very high temperature the alumina was reduced ( $\text{Al}_2\text{O}_3 + 3\text{C} = 2\text{Al} + 3\text{CO}$ ) and the resulting aluminum combined with the copper to form aluminum bronze. This was the forerunner of the various types of electrothermal operation described in the following paragraphs.

**Iron and Steel** can be produced by reducing iron ore with carbon in an electric furnace. For example, a mixture of magnetite and carbon can be heated by passing a current through it, as in the Cowles aluminum bronze process, by passing the current through a carbon core in contact with the material as in the carborundum process; or by the action of an arc as in the carbide process. The reaction is simply  $\text{Fe}_3\text{O}_4 + 4\text{C} = 3\text{Fe} + 4\text{CO}$ . Pure iron, cast iron or steel may be produced, depending upon the proportion of carbon. The chief advantages are the directness of the process and the fact that no impurities (sulphur, silicon, etc.) are introduced in the fuel, besides a considerable saving of fuel over the ordinary steel furnace. On the other hand it is a question of location, whether the electric furnace can compete in economy with the blast furnace, the Bessemer converter, and the open-hearth furnace. Pig iron has been made in the electric furnace in places like California and Norway, where water power is cheap and fuels expensive. The grade of iron thus produced is equal to the best Swedish charcoal iron, and commands a higher price than ordinary pig iron.

The chief utilization of the electric furnace in the iron and steel industry, however, is not in the direct production of pig iron or steel, but in the conversion of low-grade metal from the Bessemer or open-hearth into a high-grade metal, or in the remelting and refining of scrap steel for high-grade castings. Ordinary metal from the Bessemer converter or the open-hearth furnace can, in the electric steel furnace, be converted into metal of crucible quality or better, at a lower cost than crucible steel, and in large quantities, up to 25 tons to the charge.

**Ferro-alloys.**—One of the most important developments in the steel industry in recent years has been the production of the various alloy steels,—steels in which some special property is secured by the addition of some other metal to the simple alloy of iron and carbon. The simplest way to produce these steels is by the addition to ordinary steel of the proper amount of an iron alloy carrying a high percentage of the metal desired. This ferro-alloy is usually, though not always, made electrothermally by the reduction by carbon in an electric furnace of an oxide of the metal, in contact with

metallic iron to take up the reduced metal. Sometimes a reduction is made of a mixture of iron oxide and the oxide of the metal in question, but this necessitates the supplying of electric energy for the reduction of the iron, as well as of the alloying metal; and the iron can usually be reduced more cheaply by other methods. Under these conditions the reduction of the oxide is much more readily accomplished than if there were no iron present, since the iron considerably reduces the melting point of the resulting mixture. The type of furnace used varies somewhat with the metal being produced, but in general are quite similar to those used for the production of calcium carbide.

The alloys that are made in this way are: ferromanganese, ferrosilicon, ferrochromium, ferromnickel, ferrotungsten, ferromolybdenum, ferrovanadium, and ferro-uranium.

**Silicon Carbide.**—Known under the trade names "carborundum," "crystolon," and "exolon" silicon carbide is produced in large quantities by the process invented by E. G. Acheson. It is formed by intensely heating in an electric furnace a mixture of 35 per cent of ground coke, 52 per cent of sand, and about 11 per cent of sawdust and 2 per cent of salt, the yield being seven or eight tons of crystalline carborundum and a considerable amount of the amorphous material. The furnaces used at Niagara Falls consist of simple brick hearths 28 feet long and 11 feet wide, with brick walls at each end, these being about three feet thick and six or eight feet high. The side walls are built without cement or mortar to allow the escape of gases and because they have to be pulled down at the end of each run to discharge the furnace. In the middle of each of the end walls there are iron frames holding together a large carbon electrode built up from a number of small electrodes, through which the current is led to a core about two feet in diameter composed of broken coke and extending the entire length of the furnace. This core is raised to a very high temperature by passing through it an alternating current, using about 1,600 kilowatts. The heat from the core permeates the mass and converts it at a temperature of about  $2,200^\circ \text{C}$ . ( $4,100^\circ \text{F}$ .) for some distance around the core into silicon carbide. The unchanged material on the outside is worked over in the next charge. The coke of the core is converted into graphite. The shell of carbide is broken up after the furnace has cooled and is used in the manufacture of grinding wheels and other forms of abrasives. It is also used to a limited extent as a refractory material, since it is stable at high temperatures and is a good conductor of heat.

**Siloxicon.**—This substance is an oxygen-carbon-silicon compound, intermediate between silica and carborundum. It is formed in the electric furnace by reducing silica with carbon, but not carrying the reduction so far as with carborundum. Siloxicon is an exceedingly refractory material, neutral toward both acid and basic slags, and infusible and insoluble in molten metals. It is used as a furnace lining, either made into bricks or as a protective wash with sodium silicate.

**Silicon.**—The production of metallic silicon (90 to 95 per cent pure) has been accomplished by the extension of the principles used in the production of silicon carbide and ferro-silicon.

It is made in an arc furnace consuming 1,200 to 1,500 horse power, having two electrodes dipping down into the charge, consisting of coke and sand. The principal impurities are iron and aluminum, with some carbon.

**Titanium Carbide.**—This compound can be made by a process exactly as for carborundum, but substituting the mineral rutile (titanium oxide) for the sand of the charge. Made into electrodes for arc lights, titanium carbide gives twice the light given by carbon electrodes.

**Calcium Carbide.**—The earliest of the large electric furnace industries to be established was the manufacture of calcium carbide. It is made in the electric furnace by the interaction of lime, CaO, and carbon, usually in the form of coke or anthracite coal. Charcoal can be used, and in fact, on account of its purity, is the most desirable of the three, but is always more expensive. The raw materials should be as pure as possible, in order to prevent the collection of impurities in the product. Phosphorus and arsenic are particularly to be avoided as impurities, and sulphur is also undesirable. The lime and fuel, coarsely crushed, are mixed and charged into the furnace, where they are heated to the reaction temperature mainly by the direct action of the arc.

The furnaces for the manufacture of carbide are all of the arc type and only a small portion of the heating is done by resistance. They may turn out the carbide either in solid blocks or as a liquid, to be tapped out as collected. Formerly the furnaces were of the block type, but now many are going over to the tapping furnaces.

The earliest form of furnace consisted of an electrode suspended in a car, which served as the other electrode and as a container for the carbide. This form of furnace was small and of low efficiency, 100 to 200 kilowatts at 40 to 70 volts, with a power consumption of 6 to 7 kilowatt hours per kilogram of 85 per cent carbide, an efficiency of only 40 per cent. The losses of raw materials were also high.

The modification of the block furnace for continuous operation, the solidified material being drawn away from underneath the working zone of the furnace, made possible a decrease in power consumption to 4.5 kilowatt hours per kilogram of carbide. The size of the furnace was also increased up to 375 kilowatts.

Tapping furnaces are much larger, up to 1,200 to 1,400 kilowatts and have a power consumption of 4.2 to 4.5 kilowatt hours per kilogram of carbide. One ton of product requires 900 kilograms of lime and 600 kilograms of anthracite coal.

Three-phase carbide furnaces have been built up to 3,000 kilowatts per phase, or 9,000 kilowatts per furnace. This proved to be the limit in furnace extension for single units, as the handling of larger currents at the electrodes gave excessive heat and volatilized the charge. A unit of double this size was constructed by including two three-phase electrode systems in one furnace jacket. This gives an 18,000 kilowatt furnace with 6 electrodes, each electrode carrying up to 45,000 amperes. A furnace of this size will produce carbide with a power consumption of 4 to 4.2 kilowatt hours per kilogram. Using charcoal as a source of car-

bon, the power consumption can be cut as low as 3.8 kilowatt hours per kilogram, equivalent to about 69 per cent efficiency, but the extra cost of the charcoal over that of the coal will probably overbalance the extra saving in power.

**Cyanamide.**—A large portion of the calcium carbide now made is for use as a raw material for the manufacture of calcium cyanamide. The carbide after being finely ground is heated to temperature of about 1,000° C. (1,830° F.) in a special type of electric furnace, in the presence of pure nitrogen. The nitrogen combines with the carbide forming CaCN<sub>2</sub>. This formula calls for 35 per cent of nitrogen in the product, but since the carbide is never entirely pure and since it is not entirely converted, the resulting product carries about 20 per cent of nitrogen.

The process was originally developed for the production of a fertilizer material to replace the more expensive sodium nitrate or ammonium sulphate, but processes have since been developed for the conversion of the nitrogen of the cyanamide into ammonia and for the oxidation of the ammonia into nitric acid, thus providing a means for the chemical utilization of the nitrogen of the air. This same result has been secured by the direct oxidation processes for atmospheric nitrogen, which will be considered later.

**Graphite.**—Artificial graphite was first considered as a commercial possibility when it was noticed that in the carborundum furnaces masses of graphite frequently resulted from the overheating of the carborundum in the center of the furnace, the carborundum being decomposed and the silicon volatilized, leaving the carbon as graphite. The process was then carried on with the intentional overheating of the entire charge, with the result that it was converted into graphite. It was eventually found that all carbides decompose with the formation of graphite and the volatilization of the metal, and that it was not necessary to make up a carborundum charge to secure graphite, but that any carbonaceous material could be graphitized that carried a uniform mixture of metallic oxides, for example, coke or anthracite coal. The next step was the graphitization of molded carbon materials, particularly electrodes, it being only necessary to incorporate uniformly throughout the body, while in the process of manufacture, a small percentage of some metallic oxide, preferably Fe<sub>2</sub>O<sub>3</sub>, this being largely volatilized out in the course of the graphitization. The amount of amorphous graphite produced in this way now amounts to about ten million pounds annually, and the electrode material graphitized to at least half that amount.

**Alumina.**—Electrically fused alumina under the trade-names of "alundum" and "aloxite" is used mainly for abrasive purposes and to a lesser extent as a refractory material mainly for laboratory apparatus. The process consists in fusing down pure calcined bauxite in an electric furnace. The furnace is of the crucible type with two electrodes dipping into it. When the furnace is filled it is shut down, the sides stripped off and the block of alumina, weighing about five tons, is cooled slowly and then broken to lump form for shipment. The furnace works at 110 volts and 2,500 amperes, consuming 275 kilowatts. The energy consumption is about 2.1

kilowatt hours per kilogram of alumina. This is about half the power requirement for carborundum, but the raw material is more expensive, so that the product is a trifle more expensive than carborundum.

**Fused Quartz.**—Fused silica ware is now made by several manufacturers, and almost any shape can be secured that is made in glass, providing the size is not too great. The price of the material is still quite high. Pure silica is fused in a small electric furnace and the main difficulty encountered is the heating of the silica to a sufficient temperature for it to flow easily (2,000° C. or 3,600° F.) without excessive volatilization and without the silicon combining with the carbon electrodes to form siloxicon or silicon carbide.

**Phosphorus.**—The disadvantages of the old chemical methods for the manufacture of phosphorus were considerable, the reduction of phosphoric acid or a phosphate giving a very low yield. The operation is now carried on electrothermally, reducing a mixture of bone ash, calcined phosphate rock or calcined wavelite (AlPO<sub>4</sub>) with carbon and sand. The phosphorus distills off and is collected under water, and the calcium or aluminum silicate slag is drawn off intermittently. The yield of phosphorus is 80 to 90 per cent and the furnace requires 11.6 kilowatt hours per kilogram of phosphorus.

**Carbon Bisulphide.**—The chemical manufacture of this substance was attended with considerable difficulty, but the electrothermal production works very easily, and one plant supplies the entire demand of this continent. A current of electricity passing through a granular carbon resistor volatilizes sulphur to vapor, which passes up through a column of hot charcoal above the resistor, forming CS<sub>2</sub>, which is drawn off from the top of the furnace and condensed. The energy consumption is about 1.15 kilowatt hours per kilogram of CS<sub>2</sub>, an efficiency of about 35 per cent.

**Nitrogen Fixation.**—The direct oxidation of the nitrogen of the atmosphere for the production of nitric acid and ammonia is a result long sought by numerous investigators, but it is only within recent years that it has become a commercial possibility. This has now been accomplished in three types of processes. One of these, the direct combination of nitrogen with hydrogen to form ammonia, is more chemical than electrothermal, and so does not concern us here. The second type of process is a more or less indirect conversion of the nitrogen, largely electrothermal in character and is treated in the preceding paragraphs on *Calcium Carbide* and *Cyanamide*. The third type of process is the direct combination of atmospheric nitrogen and oxygen to form nitrous oxide under the influence of a high-tension electric discharge. This process is generally known as the arc process, while the preceding process is known as the cyanamide process.

The arc process, while a very interesting development from an electrochemical standpoint and as the pioneer in the field, cannot cope with the cyanamide process either in cost of operation or in efficiency. One of the simplest forms of apparatus and at the same time one of the most satisfactory is that of

Birkeland and Eyde. If an arc is struck between two high-tension electrodes, it immediately tends to break down to a low-voltage arc, at a high current, but if the arc is placed between two powerful electromagnets the electromagnetic force will bend the arc out from the line of the electrodes, in a semi-circular form. As the arc spreads and becomes longer, the current drops and the voltage at the electrodes increases and soon reaches a point where a second arc strikes across between the electrodes in the same manner, to be immediately followed by others until the first arc formed reaches such a length that the voltage is no longer able to sustain it. Since an alternating current is used, the succeeding arcs form on opposite sides of the electrodes and, with proper regulation, maintain a circular sheet of flame, composed of a series of arcs progressing outward till they are extinguished either by becoming too long to be maintained by the voltage available or by the reversal of the electromotive force at the end of every half period of the alternating current.

This disc of flame, which is about 1.6 metres in diameter, is enclosed in a furnace and a current of air is forced out radially on each side of the arc. Furnaces are in operation, taking 3,200 to 4,000 kilowatts at about 5,000 volts, of which 3,300 to 3,900 volts are across the arc, the remainder being the drop in the series inductances. The frequency is 50 cycles, the power factor is 66 to 68 per cent and the current 940 amperes. The gas from the furnaces carries 1 to 1.2 per cent NO, and the yield of HNO<sub>3</sub> is about 67 grams per kilowatt hour.

The Paulding process is similar in principle to the Birkeland-Eyde, but differs in application. Here the succession of arcs is produced not by magnetic deflection but by blowing the blast of air that is to be treated between the two electrodes, thus accomplishing the same end as the magnet of Birkeland and Eyde, except that the sheet of flame extends on one side of the electrodes only. The gas from the Paulding furnace is somewhat richer than that from the Birkeland-Eyde furnace, but the yields are somewhat lower. Each furnace contains two 200-kilowatt arcs in series, at 4,000 volts, taking 140 amperes at a power factor of 70 per cent.

In comparison with these processes, the Schönherr process is of interest, this being based on a different principle. Both the Birkeland-Eyde and the Paulding processes recognize the difficulty of maintaining a high-tension arc, particularly when subjected to a current of air, and so means are provided for securing a rapid succession of arcs as fast as they are extinguished. As a matter of fact, the arcs are made to overlap, so several exist in parallel at the same time. Schönherr, however, attacked the problem of maintaining a stable high-tension, high-current arc, working on the principle that if the air current were so introduced that it did not deform the arc, the discharge could be maintained in a stable condition. Paulding used the air current, at right angles to the arc, to draw the arc out to a greater length. Schönherr secured the same result without destroying the arc by introducing the air tangentially from all sides simultaneously so that it traveled with a helical motion in the direction of the arc. This neither deformed



the arc nor overcooled it, allowing it to burn quietly. Working on this principle, the commercial furnaces designed by Hessberger take 700 to 750 kilowatts, 3,500 volts and 290 amperes with a power factor of 66 per cent. The arc carried is from 5 to 7 metres (16 to 22 feet) in length. The gases carry 1.5 to 2 per cent NO and the yield is 68 grams HNO<sub>3</sub> per kilowatt hour.

Ozone is a polymerized form of oxygen which may be produced by a silent electric discharge from a static electric machine, induction coil or very high voltage transformer, through oxygen or air.

It has powerful oxidizing and bactericidal properties and is extensively used in water and air purification.

**Other Compounds.**—Many other compounds, too numerous to describe, are made by electrochemical processes of one kind or another. For details of the principles involved in the operations of such processes, see **ELECTROCHEMISTRY**, **ELECTROLYSIS**, **ELECTRIC FURNACES** and **METALLURGY**. For details on individual subjects, see under the name of the substance in question.

**Bibliography.**—Allmand, A. J., 'Applied Electrochemistry' (London 1912); Borchers, W., 'Electrometallurgy' (New York 1905); Loeb, W., 'Electro-Chemistry of Organic Compounds' (New York 1907); McMillan, W. G., and Cooper, W. R., 'Electro-Metallurgy' (London 1910); Thompson, M. de K., 'Applied Electrochemistry' (New York 1911); Watt, A. and Philip, A., 'Electric Plating and the Electric Refining of Metals' (London 1910); *Metallurgical and Chemical Engineering* (New York, semi-monthly); Transactions of the American Electrochemical Society (South Bethlehem, Pa., semi-annually).

G. A. ROUSH,  
Assistant Secretary American Electrochemical Society.

**ELECTROCHEMICAL SERIES**, the arrangement of the chemical elements in the order of their ability to replace one another in a solution.

**ELECTROCHEMICAL SOCIETY**, American. The American Electrochemical Society was organized 3 April 1902, at Philadelphia, Pa., the objects of the society, as stated in its constitution, being the advancement of the theory and practice of electrochemistry. The charter members of the Society numbered 337, while the membership at the close of the year 1917 was about 1,600. Since its organization, the Society has held two meetings each year, in the Spring and Autumn, for the presentation and discussion of papers on electrochemical subjects. These meetings have been distributed as follows:—New York city, 9; Niagara Falls, 4; Atlantic City, 2; Boston, 2; Philadelphia, 2; Pittsburgh, 2; Washington, 2; and one each in Albany, N. Y.; Bethlehem, Pa.; Chicago, Ill.; Detroit, Mich.; Denver, Colo.; Ithaca, N. Y.; Saint Louis, Mo.; San Francisco Cal.; Toronto, Can. Since the membership of the Society includes practically all of the prominent electrochemists of the United States, as well as many in foreign countries, the Society has naturally played an active part in scientific developments in the years since its organization.

**ELECTROCHEMICAL TELEGRAPH**, a telegraph which records signals upon a paper sheet or strip moistened with a chemical solution, which is decomposed by the electric current. See **TELEGRAPHY—Chemical Automatic Telegraphs**.

**ELECTROCHEMISTRY**. That branch of chemistry which treats of the utilization of electrical energy to facilitate or carry on a chemical reaction is known as electrochemistry. This end may be accomplished in one of three ways: by electrolysis, by electrothermal action, or by the discharge of electricity through gases. Conversely, electrochemistry also includes those reactions by which electricity is generated by means of chemical action. It was the Italian physicist Alessandro Volta (q.v.), a professor in the University of Pavia, who first discovered that when two metals and a liquid are combined in a circuit an electric current is produced. It was also Volta, who, for the first time, distinguished between the two classes of electrical conductors, recognizing the difference between metallic conductors and electrolytic conductors, which is the foundation of all electrolytic work. Soon after this he established what has been called the contact electromotive series, which is a table of metallic conductors arranged in such order that if any two of them be connected with each other and also with an electrolytic conductor, an electric current will flow through the liquid from the metal higher in the series to the one lower in the series, and the current increases in magnitude the farther apart the two metals are in the series. Following this, it was discovered by Ritter, that the order of the metals in this series was the same as the previously known order in which metals replaced each other in solutions of their salts. This discovery was the first bond of linkage between the newer science of electricity and the older one of chemistry, and marks the birth of our modern electrochemistry. Volta's contact electromotive series soon led to the development of the voltaic pile (q.v.), the first device for the generation of electric current, and one dependent entirely on electrochemical principles. In his work on the pile, Volta could hardly have failed to notice the formation of gas bubbles on the metals immersed in his solutions, and the fact that he makes no mention of these phenomena indicates that he did not appreciate the significance of the reactions that were taking place. It remained for Nicholson and Carlisle in 1800 to record the formation of hydrogen and oxygen on passing the electric current through water. In the study of the various decompositions it was soon noted that there was a formation of alkali at the negative pole in the electrolysis and of acid at the positive pole. Following up these observations led to the discovery by Davy in 1807 of the alkali metals, sodium and potassium, which he separated by electrolysis of the fused hydrates, thus laying the foundation for the development 100 years later of the Castner process of manufacture of metallic sodium on a commercial scale. (See **ELECTROCHEMICAL INDUSTRIES**). It was Berzelius, the great Swedish chemist, who devised the first theory for the explanation of the nature of chemical compounds, based upon electrochemical observations. The Berzelius theory dominated this new science and the parent

science of chemistry as well for many decades, but in turn was supplanted by other theories. During its lifetime, however, it served as the basis for an enormous amount of valuable discussion and research. According to the Berzelius theory, chemical atoms behave similarly to a magnet, having a positive and negative pole, but in the case of some elements the positive pole is much the stronger of the two and in others the negative pole is the stronger. Consequently the atom behaves in accordance with the character of the predominating pole, and the positive or negative character of the predominating pole of the atoms, and its relative strength, determine the chemical character of the element. Atoms of an electropositive character can then combine with those of electronegative character, in proportions determined by their relative strength, thus neutralizing each other more or less, but not necessarily completely. If complete neutralization does not result from the first combination the result is a compound which is more or less electropositive or electronegative, depending on which charge predominates, and compounds of this kind of opposite polarity can still further combine for more complete neutralization. Combinations of certain elements thus gave compounds of an acid character while others gave compounds of a basic character, and these combine to form salts, which, if not completely neutralized, can still further combine to form double salts.

After the establishment of the Berzelius theory, no great progress was made along electrochemical lines until about 1835, when Faraday announced his discovery of what are now known as Faraday's laws, which will be discussed later. Faraday received his taste for scientific work and the training that led up to it while serving as a helper in the laboratory of Sir Humphrey Davy, and Davy is said to have once replied, in answer to a question, that his most important scientific discovery was Michael Faraday. Besides the laws governing the quantitative relations of electrochemical reactions, we also owe to Faraday our system of electrochemical nomenclature. To explain the reactions taking place he assumed the passage of the electricity to be associated with the movement in the solution of particles of matter which he called *ions*; the poles themselves were in general termed *electrodes*, the positive pole being the *anode* and the negative pole the *cathode*; the ions that moved to the positive pole were *anions*, and those moving toward the negative pole were *cations*; the solution undergoing decomposition was the *electrolyte*, that surrounding the anode being the *anolyte*, and that surrounding the cathode the *catholyte*; the process of decomposition was called *electrolysis*.

When the decomposition of water was first noticed, an explanation was sought for the simultaneous appearance of hydrogen at one electrode and of oxygen at the other. In 1805 Grothius proposed a theory to explain the mechanism of the conduction of the electric current through the solution and opened the discussion of a problem for which we still have no entirely satisfactory solution. According to the Grothius theory, the current charges one electrode positively and the other negatively,

and these charged surfaces in turn act on the molecules of water in such a way that the hydrogen of the water becomes positively charged and the oxygen negatively charged. The attraction of the negative pole for the positively charged hydrogen and of the positive pole for the negatively charged oxygen then causes the molecules to arrange themselves as shown in A of Fig. 1. If the charge on the two electrodes

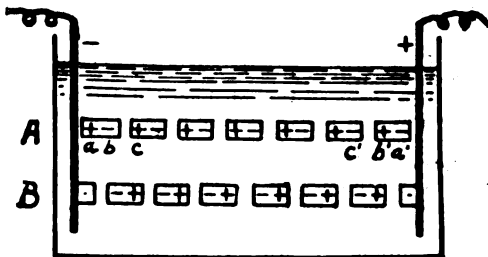

FIG. 1.

is then sufficient, the atoms *a* and *a'* have their charges neutralized at the electrode and become free gas; the atoms *b* and *b'* then recombine with *c* and *c'* and so on throughout the line, forming new molecules of water, as in B, which then, under the continued influence of the current, will reorient themselves as before and the whole process is repeated. This theory held its own for about 50 years, but as the science developed, imperfections were discovered that made it no longer tenable, and it was eventually replaced by the Clausius theory. Clausius assumed that the positive and negative portions of the molecule in the electrolyte were not firmly combined with each other, but were in a state of continuous vibration, which if it became vigorous enough would cause the positive part of one molecule to come within the sphere of influence of the negative part of another molecule, with which it would unite, the negative and positive particles thus left temporarily free in turn soon come within the sphere of other oppositely charged particles with which to unite, so that there would be going on through the solution all the time a continuous interchange between the particles. But when an electric current is sent through the solution, a force is generated in the direction of the flow of the current and the vibration and exchange is no longer irregular, and in all directions, but is intensified in the direction of the current flow, thus causing a movement of positive particles toward the negative pole, and vice versa.

The Grothius idea of fixed ions was thus replaced by the vibrating ions of Clausius, and this in turn, some 30 years later, was replaced by the Arrhenius theory of free ions. This theory has probably given a greater impulse to electrochemical research and has, directly and indirectly, been an aid to more discoveries than any other conception in the field of electrochemistry. The Arrhenius theory, or as it is frequently called, the electrolytic dissociation theory (see SOLUTIONS) was based on the assumption that when an acid, base or salt was dissolved, yielding a solution that was a conductor of electricity, the molecules of the dissolved substance were by the act of solution de-

composed into part-molecules, or ions. At any finite concentration the solution will still contain a certain amount of undissociated material, and only at infinite dilution is the substance completely dissociated into ions. These dissociated ions are positively and negatively charged, and it is the ions that act as carriers of the current, the conductivity of the solution being dependent on the degree of dissociation of the dissolved substance.

The discrepancies that constantly cropped out in the development of the details of the Arrhenius theory led up to what is known as the Hydrate theory, which assumes that part of the water present in the solution is combined with the dissolved substance, thus leaving as free solvent only a portion of the total amount present, which from a concentration standpoint would bring about the same results as the assumption according to the Arrhenius theory of an increase of the ultimate particles in the solution by dissociation. And this idea, in turn, becomes the Solvate theory when its principles are extended from aqueous to all solutions, both aqueous and non-aqueous. This Solvate theory, supplementing the Arrhenius theory, extends the latter from its former constricted field of dilute solutions to a theory of solutions in general. There are still, however, many points that need further development, particularly with regard to the exact relation between dissociation and solvation.

If the law of conservation of energy holds, there must necessarily be a direct relation between electrical energy and chemical energy on the one hand and heat energy on the other. This brings us first to the discussion of *Faraday's laws* (q.v.), two of the most fundamental statements in natural science. Faraday's first law specifies that the amount of chemical action produced by an electric current in a circuit is directly proportional to the quantity of electricity which passes through the circuit. The second law specifies that the quantities of different substances which are produced by the same amount of electricity passing are directly proportional to the chemically equivalent weights of the substances concerned. These effects are entirely independent of the concentration or temperature of the solution, the size or distance apart of the electrodes, and all other conditions. These laws hold with great exactness not only for ordinary aqueous solutions, but also for non-aqueous solutions and for fused salts. The quantity of electricity that is necessary to deposit the chemically equivalent weight of any substance is 96,500 coulombs (ampere seconds) and this unit quantity is known as a Faraday, after its discoverer. Another, and possibly better, way of stating this is to say that one Faraday of electricity, 96,500 coulombs, is required to make a unit change in valence of any element or radical. One Faraday then will deposit as metal 56/3 grams of iron from a solution of ferric iron (a change of three valences) or it will reduce 56 grams of iron from ferric to ferrous, a change of one valence. This holds equally well whether it is a decrease of valence accompanying a chemical reduction, or whether it is an increase of valence accompanying an oxidation. The fact that 96,500 coulombs will deposit one chemical equivalent of an element makes it possible to calculate from this rela-

tion the amount of any element that would be deposited by any given amount of current. According to this, one coulomb should deposit

$$\frac{1.008}{96,500} = 0.00010446 \text{ grams of hydrogen or}$$

$$\frac{63.57}{2 \times 96,500} = 0.0003294 \text{ grams of copper. These}$$

values are known as the *electrochemical equivalents* (q.v.) and can readily be calculated for any material. The ampere-second values are usually used for scientific work, but for practical work in the plant, larger units for the ampere hour or ampere day may be used. Faraday's laws refer only to *quantities of electricity* involved in bringing about certain changes, but say nothing about the *quantities of electrical energy* necessary for the change. To arrive at values for the energy involved, we must consider not only the *quantity* factor of the current used, but also the *intensity* factor. In other words, Faraday's laws deal with ampere changes, while the energy involved is concerned with amperes  $\times$  volts, or watts.

All chemical reactions can be compared from an energy standpoint on the basis of the thermochemical changes accompanying the reaction.

$$1 \text{ calorie} = 4.186 \text{ watt seconds}$$

$$1 \text{ watt second} = 1 \text{ coulomb} \times 1 \text{ volt}$$

$$\text{or } 1 \text{ volt-coulomb} = 0.2389 \text{ calorie.}$$

Then 1 volt-Faraday =  $0.2389 \times 96,500 = 23,054$  calories. Any given reaction involving one Faraday will then require as many volts as the heat balance of the reaction will contain 23,054. For example, the heat of formation of water is 69,000 calories, and to decompose it an equivalent amount of energy must be supplied. A molecule of water,  $H_2O$ , includes two chemical equivalents, so per chemical equivalent, there must be supplied 34,500 calories. The voltage required for the decomposition will

$$\text{then be } \frac{34,500}{23,054} = 1.495 \text{ volts. The decom-}$$

position of one molecular weight (18 grams) of water then by electrical energy would require  $2 \times 96,540 = 193,080$  ampere seconds of electricity

$$\text{at a voltage of } 1.49 \text{ volts, or } \frac{193,080 \times 1.49}{3600 \times 1000} = 0.08 \text{ kilowatt hours of electrical energy.}$$

This same principle can be applied to the calculation of the electromotive force of primary or secondary batteries (q.v.) when applied to the thermochemical balance of the chemical reaction that takes place in the cell. The chemical reaction in the Daniell cell is



The heat of formation in dilute solution of  $CuSO_4$  is 197,500 cal. and of  $ZnSO_4$  is 248,000 cal., leaving an excess of  $248,000 - 197,500 = 50,500$  cal. for two Faradays, or 25,250 cal. for

$$\text{one Faraday. } \frac{23,250}{23,054} = 1.094 \text{ volts supplied by}$$

the cell.

The reaction on charging a lead storage battery is

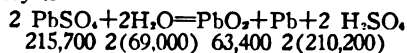

$$215,700 \quad 2(69,000) \quad 63,400 \quad 2(210,200)$$

This reaction shows a deficit of  $569,400 - 473,800 = 95,600$  cal. for 1  $PbO_2$  (two Faradays) or

47,800 cal. for one Faraday. It will then require  $\frac{47,800}{23,054} = 2.073$  volts to charge the cell,

and since the reaction is reversible, when once charged, it will be capable of generating the same voltage.

Of the phenomena accompanying electrolysis with unattackable electrodes, two of the most interesting are polarization and over-voltage. With electrolyses that are more or less reversible, it may be noted that after the passage of the current has caused some decomposition, there is a tendency for recombination of the materials present at the electrodes. If the current is stopped, it will be noted that for a short time there will be generated a small current in the opposite direction from that of the current originally imposed. This is known as the *polarization current* and the voltage generating it is known as the *polarization voltage*. This polarization voltage, being in the reverse direction from the voltage causing the original electrolysis, will reduce the electromotive force on the cell, and the current passing. In an electrolysis involving the separation of a free gas on an unattacked electrode, it is well known that the voltage required for decomposition is greater than that calculated from the heat of formation. This excess of voltage required over the theoretical is called *over-voltage*, or more recently, *gas voltage*. These voltages vary widely for various metals and an explanation of the differences has long been sought. Recent investigations seem to indicate that the differences are mechanical rather than chemical. Calorimetric measurements show that the amount of electrical energy disappearing as chemical work is the equivalent of the normal decomposition voltage for the reaction taking place, and that the over-voltage appears in the solution as heat. This would indicate that the nature of the over-voltage was mechanical, and the probable explanation is that it represents the amount of energy necessary to overcome the resistance of the film of gas on the electrode. The gas as first formed on the electrode is a thin film over the entire surface, and then as the amount of gas increases surface tension begins to act to form the film into bubbles of gas which detach themselves from the electrode and escape from the solution. The amount of energy necessary to force the current through this gas film over the surface of the electrode will of course increase with the thickness of the film, and in turn the thickness of the film will be dependent on the ease with which the gas mechanically separates itself from the surface of the electrode. This will naturally vary with the material of the electrode and with the condition of its surface.

When the products of an electrolysis are stable and can be removed from the cell in the form in which they were deposited, there is no reaction taking place except the electrolytic decomposition itself and this is said to be a *primary* reaction. In many cases, however, the products of electrolysis undergo further reaction and appear in some other form than that in which they were originally deposited. In this case the reaction is said to be *secondary*. These secondary reactions may be divided into two classes, depending on whether the products of decomposition react on the material of

the electrodes, or whether they react on the electrolyte. If desired, each of these classes can be still further subdivided into two classes, the first as to whether the action is on the cathode or on the anode, and the second as to whether the action is on the catholyte or anolyte. For example, if a solution of sodium sulphate were electrolyzed the primary reaction would result in the deposition of metallic sodium on the cathode and of the  $\text{SO}_4$  radical on the anode. The sodium would then react with the water in the electrolyte with the formation of  $\text{NaOH}$  and hydrogen, while the  $\text{SO}_4$  would react with the water, forming  $\text{H}_2\text{SO}_4$  and oxygen. On the other hand, if a solution of  $\text{NaCl}$  were electrolyzed with a mercury cathode and a silver anode the sodium set free at the cathode would react on it with the formation of an amalgam, and the chlorine set free at the anode would combine with it with the formation of  $\text{AgCl}$ . Since the electrolysis of the water of an aqueous solution results in the formation of hydrogen at the cathode and of oxygen at the anode, we can have in the solution as the result of secondary reaction either a reducing or an oxidizing action by using conditions which favor the absorption in the solution of whichever is desired. A large electrode and a low current density favor the absorption of the gas in the nascent condition as fast as formed, while a small electrode and a high current density tend to cause the throwing off of the gas as free bubbles almost as fast as formed and with only a limited opportunity for absorption. Low current density at the cathode and high at the anode will then give a strong reducing action, while high density at the cathode and low at the anode will give strong oxidizing action. For further discussion of the phenomena accompanying the passage of a current of electricity through a solution, see the article on ELECTROLYSIS.

In electrothermal applications it is the heating action of the current that is sought rather than its chemical action at the electrodes during electrolysis. An apparatus for the utilization of the heating action of the current for carrying on a high-temperature reaction is known as an electric furnace. In case the combined action of the high temperature and the chemical action of the current are both used, the apparatus is called an electrolytic furnace. In the former, as a matter of convenience and economy in handling the current, alternating current is usually used; in the latter, since electrolysis is sought, direct current is a necessity. See ELECTRIC FURNACES and ELECTROCHEMICAL INDUSTRIES.

Many of our present day commercial operations require temperatures higher than are attainable from the combustion of a fuel, and for operations of this kind electric heating is a necessity. In many other cases it has been found more economical to substitute electric heating for combustion heating. The particular economy in electric heating is due to the fact that the heat is generated within the charge being heated and does not have to be forced through the refractory wall of the container which, on account of its low conductivity, imposes a heavy loss in efficiency. It is also possible to secure certain electrochemical effects by the passage of a high tension electric discharge through gases. The two chief reactions

of this kind are the conversion of oxygen, O<sub>2</sub>, into ozone, O<sub>3</sub>, and the oxidation of atmospheric nitrogen to nitric acid. (See **ELECTRO-CHEMICAL INDUSTRIES**). Both of these reactions were first noted in the early years of electrical development, the former by Van Marum in 1785, and the latter by Priestly in 1779, but in both cases nothing was done in the way of study or development of the reactions until many years later, mainly within the last 30 years.

**Bibliography.**—Allmand, A. J., 'Applied Electrochemistry' (New York 1912); Jones, H. C., 'Outlines of Physical Chemistry' (New York 1915) and 'The Theory of Solutions' (New York 1917); Le Blanc, M., 'Textbook of Electrochemistry' (New York 1916); Thompson, M. deK., 'Applied Electrochemistry' (New York 1914); 'Transactions of the American Electrochemical Society' (Bethlehem, Pa., semi-annually).

G. A. ROUSH,  
*Assistant Secretary, American Electrochemical Society.*

**ELECTROCHRONOGRAPH.** See **CHRONOSCOPE**.

**ELECTROCIDES**, the amber islands of Greek mythology, at the mouth of the river Eridanus. The name was applied also to the islands on the northern coast of Europe.

**ELECTROCULTURE OF PLANTS**, the employment of electric light in agriculture and horticulture. It was determined at the Agricultural Experiment Stations of Cornell University and of West Virginia, in experiments made with the arc and the incandescent lights, respectively, that certain crops are forwarded by the light. The most remarkable instance is that of lettuce, which was brought to maturity in from 5 to 10 days earlier than other plants grown in the same house and under otherwise identical conditions. This discovery has led to the commercial application of the arc light, if not of the incandescent also, to the forcing of lettuce under glass in several of the larger New England forcing houses, with the result that a gain of about three weeks' time is calculated upon for the season, thus enabling the gardener to devote his benches to one more crop than formerly or to follow his lettuce crops with cucumbers, the favorite successor, much earlier than would otherwise be possible. Several flower crops, such as Easter lilies and sweet-pease, have been experimented upon, with the result that they were forced into bloom several days in advance of others grown without the stimulus. In such cases the plants are always grown without the light until within about a month of maturity, when the light is applied for about half the night. It has been found that unless the light pass through a glass globe or pane there is a noticeable "scorching" of the foliage or flower. It is concluded that this is due to the action of the ultra-violet rays of the spectrum rays, which do not pass through the glass. Consult various bulletins of the Massachusetts, Hatch, Cornell University and West Virginia Experiment stations. See **ELECTRIC VEGETABLE GARDENING**.

**ELECTROCUTION**, capital punishment by the agency of electricity. See **ELECTRICITY, CAUSE OF DEATH BY**.

**ELECTRODE** (Greek, *hodos*, "a way"), a term introduced by Faraday to denote the conductors by which electricity either enters or leaves an electrolytic bath or solution. He termed the electrode by which the current enters the bath, the anode (positive terminal), and the electrode by which the current leaves, the cathode, sometimes spelled *kathode* (negative terminal). The terms anode and cathode have been introduced generally in metallurgical practice, and also in connection with Crooke's tubes and X-ray work, and the term electrode has become common in the more extended sense of signifying either of the terminals of an electric source, instrument or electrolytic bath or cell.

**ELECTRODEPOSITION.** See **ELECTRO-CHEMISTRY; ELECTROPLATING**.

**ELECTRODYNAMIC INDUCTION.** See **INDUCTION**.

**ELECTRODYNAMICS**, that branch of electrical science which treats of the attractions and repulsions exhibited between wires or other conductors along which currents are passing. If two wires are parallel they will attract each other when currents are passing the same way along them both and will repel each other when the currents are opposite. If the wires are inclined to each other at any angle there is not only an attraction or repulsion but a still more marked tendency to rotation which is not satisfied until the wires have become parallel and the currents flow in the same direction along them both. When there are only two straight wires these forces are feeble and require delicate apparatus for their exhibition, but by employing coils of wire the forces are multiplied and an instrument constructed on this principle called the electro-dynamometer has been much employed for the measurement of currents. The basic principles of electro-dynamics were discovered by Ampere in 1821 by many ingenious experiments, the results of which he expounded in a series of statements known to this day as Ampere's Laws.

**ELECTRODYNAMOMETER.** See **DYNAMOMETERS; ELECTRICAL MEASURING INSTRUMENTS**.

**ELECTROKINETICS.** See **ELECTRIC DIRECT CURRENT; ELECTRIC ALTERNATING CURRENT MACHINERY; ELECTRICITY**.

**ELECTROLYSIS.** With respect to their ability to conduct electricity, all substances are divided into the two general classes, conductors and non-conductors; there is, however, no hard and fast boundary line between the two, but a more or less gradual merging from one into the other. The conductors are again divided into two classes, those which conduct the current without any apparent decomposition and those in which the conduction is invariably accompanied by decomposition. In this latter class, the conduction of the current with concomitant decomposition is called electrolysis, and the liquid subjected to decomposition is termed the electrolyte. These are the names originally proposed by Faraday. True electrolysis is almost entirely confined to liquids. Evidences of electrolysis have been found, however, in a few cases in solids and similar phenomena have been observed in connection with high-tension discharges through gases. A large number of liquids, particularly of organic na-

ture, fall in the class of non-conductors. Water, and a number of other liquids of inorganic origin are also non-conductors when carefully purified. Liquids that conduct without decomposition are limited to liquid metals. Liquids that conduct with decomposition—that is, electrolytes, may be a pure liquid, a fused salt, or a solution, either aqueous or non-aqueous. In the case of solutions the conductivity is not necessarily dependent on the conductivity of the constituents of the solution, but may be a property of the solution itself. A solution of one non-conductor in another may give a solution of good conductivity.

Also, in the case of a solution, the decomposition caused by the electrolysis may affect the solvent or the solute or both, and may vary with the conditions of electrolysis. If the constituents of the solute are obtained directly at the anode and cathode, the reaction is said to be a *primary* one; but if for any reason, these constituents react on either the electrodes or the solution, the reaction is said to be *secondary*. (See **ELECTROCHEMISTRY**). Primary reactions are dependent only on the amount of current acting, and are not subject to modification by physical conditions (see **FARADAY'S LAWS**), but secondary reactions may be modified by temperature, concentration, current density and other physical conditions and in this type of reaction with its various modifications lie many of the possibilities in the field of industrial electrochemistry. (See **ELECTROCHEMICAL INDUSTRIES**). The problem of the mechanism of electrolysis is one that has attracted more attention than any other in the field of electrochemistry. A brief discussion of the early history and the present status of this problem will be found in the article on **ELECTROCHEMISTRY**. This question is also closely related to, and to a certain extent dependent on, the problem of the nature of solutions, and a further discussion of the principles involved will be found in the article on **SOLUTIONS**.

G. A. ROUSH,

*Assistant Secretary, American Electrochemical Society.*

**ELECTROLYSIS OF GAS AND WATER MAINS.** In the system of street railway traction in which an overhead trolley wire is employed, with direct current, in which the tracks are utilized as a return circuit for the current to the power-house, it has been found that damage has almost invariably ensued to the gas and water mains adjacent to the tracks, from electrolysis. This is due primarily to the electric current leaving the tracks and following the gas or water mains for some distance. At the points where the current leaves these pipes to return to the tracks or to the power-house, if the soil is damp and contains soluble chlorides of magnesium, sodium or potassium, the current sets free acids or chlorine which attack the iron of the pipes; the rapidity and extent of the damage done thereby being dependent upon the strength of the current, the duration of its application and the constituents of the soil. The electrolytic action results in "pitting" the pipes, and bursting of water pipes and leakage of gas pipes is not uncommon from this cause. (See illustration). Experiments have shown that with as low a potential as 0.5 volt and a current of 0.03

ampere, noticeable electrolysis of an iron pipe has occurred in sand moistened with sea water. Pipes on which the difference of potential was found to be about six volts have burst in a few years. To prevent electrolysis due to this cause greater precautions are now taken, and with considerable success, to preserve the continuity



Electrolytically Pitted Water Pipe.

of the rails by bonding, welding them *in situ* by electricity by providing separate metallic return circuits and by connecting the water and gas mains by means of heavy copper wire at places where the current would otherwise return to the tracks via the earth.

**ELECTROLYTE.** Any liquid which conducts the electric current with concomitant decomposition is called an electrolyte. It may be either a pure liquid, a fused salt or a solution, aqueous or non-aqueous. In the case of a solution, the decomposition may involve the solute, the solvent, or both. The name is often incorrectly applied to designate a salt which when dissolved in water will form a conducting solution.

#### **ELECTROMAGNETIC INDUCTION.**

See **INDUCTION**.

**ELECTROMAGNETISM.** The art or process of magnetizing by means of an electric current, as distinguished from so-called natural magnetism as in the lodestone, or transient magnetism, as established in a wrought-iron bar. A magnet not only attracts steel and iron in a less degree, but cobalt, nickel, manganese, cerium and chromium. Hans Christian Oersted (q.v.) is credited with being the first to recognize the identity of magnetic and electric phenomena. In 1820 he observed that wires connecting the poles of a voltaic pile affected the magnetic needle. In 1821 he wrote a long paper on electro-magnetism. Arago, Ampere, Davy and Faraday all studied and contributed to knowledge of the phenomena. In 1825 William Sturgeon of Woolwich, England, began to experiment. His two first electro-magnets were made in the shape of a horseshoe and a straight bar. The former was made of a bent rod of iron one foot in length and half an inch thick, around which a bare copper wire was wound 18 times, the iron having been previously covered with varnish to insulate the wire from the iron. The current was supplied by one large primary cell. This magnet was able to sustain a weight of nine pounds, though weighing itself only seven ounces. Subsequently Sturgeon constructed a horseshoe electro-magnet 18 inches in length,  $2\frac{3}{4}$  inches thick and wound with 980 feet of copper wire one-twelfth of an inch in diameter, which upheld 1,386 pounds. In 1831 Joseph Henry made electromagnets for both Yale and Princeton universities that lifted 3,000 pounds. Large electromagnets are now used in foundries and machine shops of a capacity of 12 or more tons.

The phenomena of electro-magnetism may be briefly described as follows: It is known that

when iron filings are strewn over a cardboard or glass, if a bar or horseshoe magnet be placed under the cardboard the filings will tend to arrange themselves symmetrically when the cardboard is tapped. This is due to magnetic lines of force which are assumed to flow from the north to the south pole of the magnet, and the iron filings, becoming temporarily magnetized by these magnetic lines of force, tend to set themselves parallel thereto. Similarly, when an electric current flows in a wire (electro) magnetic lines of force surround the wire in circles or hoops which increase in density with the strength of the current. It is known that iron is a much better conductor of magnetic lines of force (or magnetism) than air, in the ratio of 1 to 100 or 150, depending on the quality or "permeability" of the iron. Hence when the wire is made in the form of a coil into which is inserted a soft iron bar, the magnetic lines of force, so to speak, use the iron as a circuit and the latter becomes a magnet having north and south poles. A simple form of electromagnet consists of a U-shaped bar of soft iron, around which a copper wire is coiled in spirals, beginning at one extremity and extending to the other. If the iron core is placed in this position,  $\Omega$ , and winding begins at the lower left side, turning the wire around clockwise, the south pole of the magnet will be at the starting point on the left.

The space between the poles of a magnet or wherever its magnetic lines of force extend, or in the space around a wire conveying a current of electricity, is termed a magnetic "field." The substances through which the lines of force pass, including the iron of the magnet, constitute the magnetic circuit. The expression *number of lines of force per square centimeter* in the material, is at present used as a measure of magnetic density. The total number of lines of force in a magnetic circuit is termed the *magnetic flux*, and is obtained by multiplying the total cross-sectional area of the field in square centimeters by the density of a square centimeters of the circuit. The *magneto motive force* (that is, the force that, as it were, drives the lines of force through the circuit) is equal to the product of the strength of current in amperes in the coil by the number of convolutions of the coil. This is also termed the *ampere turns*. The magnetic flux may be increased by increasing the magneto motive force or by decreasing the resistance (termed the *reluctance*) of the magnetic circuit. Hence the relation of the foregoing terms to one another is analogous to that between electromotive force, resistance and current, in an electrical circuit, and may be expressed by the equation:

$$\text{Magnetic flux} = \frac{\text{Magneto motive force}}{\text{Reluctance.}}$$

It is to be noted, however, that the reluctance of a magnetic circuit containing iron is not a constant, but increases in other words, its permeability to magnetization decreases, after a certain degree of magnetization, which is termed *saturation*, has been reached.

Electro-magnets are extensively used in electric bells, in telegraph and telephone apparatus, in dynamo machines, electric motors (q.v.), and for many other purposes. See **ELECTRIC MACHINERY**.

**ELECTROMETALLURGY.** That branch of electrical science that deals with the reduction or refining of metals by electrical processes, including electrolysis (q.v.) or decomposition of chemical compounds by electricity; electro-deposition, or the depositing of metals in solution by an electric current (see **ELECTRO-CHEMISTRY**); and the fusing of metals in the electric furnace (q.v.). The electric current is capable of performing the entire work of reducing a metal from its ore, but in practice this is usually too expensive, and it is used only where there is a commercial gain. The first important application of electricity in the separation of a metal was to aluminum, which industry is based wholly on electrical processes. (See **ALUMINUM**). In copper refining, electricity has become more and more important, owing to the purity of the product which is valued commercially. There is increasing use of electrometallurgy in the production of gold, silver, zinc and the ferro-alloys. It may be used also for separating and refining platinum, lead, nickel, tin, bismuth, cadmium, etc., in fact all the metals. A perusal of the article on **ELECTRIC FURNACE** will afford the student a clear idea of the methods of electrometallurgy. Various electrolytic processes are also outlined under **COPPER**; **GOLD**; **ZINC**, etc. See also **ELECTROLYSIS**; **METALLURGY**.

**ELECTROMETER**, an instrument for determining difference of electrostatic potential (or electric charge) between two charged conductors. The electroscope (q.v.) and Coulomb's torsion balance are primitive forms. The attracted-disc electrometer was designed by Volta and developed by Snow-Harris. It consists of a battery or Leyden jar to the wires of which is attached a horizontal disc. A balance is placed close by, having on one end of the beam a disc which is positioned a short distance above the disc connected with the jar, and on the other end of the beam a pan for containing small weights. In this manner the degree of force that will pull the two discs together is weighed in ounces or pounds. To secure a correct result it was found necessary to place a guard ring around the upper disc, and this later form was named the absolute electrometer. Through this mechanism it was demonstrated that the attraction between the discs at different distances varied as the square of the difference of potential. Lord Kelvin constructed an electrometer located in the interior of a Leyden jar, and employing the torsion of a wire to measure the difference of potential. This invention was outclassed later by his quadrant electrometer. This was designed to measure the electrostatic charge by the attraction of quadrants of metal of known attractive force on a very light aluminum needle. He hung a paddle-shaped aluminum foil needle, enclosed in a box, between the four insulated metal quadrants. Opposite quadrants were connected by platinum wires. The difference of potential when connected with one pair of quadrants or the other pair was made use of to deflect the needle, and a mirror and light being provided, the needle threw a spot of light on a scale. It was found necessary to provide the instrument with a "replenisher" to preserve the charge of the Leyden jar. The quadrant electrometer was so much more delicate in its meas-

urements that it superseded the cruder instruments, and being later improved by Dolezalek and others became a standard instrument. See ELECTRIC MEASURING INSTRUMENTS.

**ELECTROMOTIVE FORCE.** Electric pressure or voltage, equivalent to difference of potential; the force that causes electricity to flow along a conductor: commonly abbreviated E.M.F. The force which gives rise to an electric current is called electromotive force and is comparable with the force exerted by water under pressure or "head," resulting from water seeking its level. In a somewhat similar way, electricity seeks a balance. When a conductor is earthed, that is connected with the earth, the electric potential becomes the same as the earth's, balance is restored and there is no flow of current and no electrical manifestation, the electromotive force being at zero.

**ELECTROMOTOGRAPH,** a name given to a peculiar telephone receiver invented by Edison and constructed virtually as follows: A short metal strip, fastened at one end to the centre of a mica diaphragm, rests on a rotating cylinder, the surface of which is composed of moist gypsum impregnated with mercuric acetate and potash. The strip and cylinder are placed in series in a telephone circuit. When variations in current pass through the gypsum surface it is found that the friction between the strip and the cylinder varies directly with the current. When the current is weak the strip is drawn along in the direction of the cylinder's rotation against the natural tension of the mica diaphragm. When the current increases, the strip slips back in response to the pull of the diaphragm and in this way the diaphragm is set into vibrations corresponding to those set up by the telephone transmitter. An explanation of this phenomena is that the current electrolytically sets free a thin layer of gas between the cylinder and strip, reducing the natural friction.

**ELECTRON THEORY** or **CORPUSCULAR THEORY.** The physical theory that the atoms of bodies are composite systems, consisting in part (at least) of corpuscles of a still higher order of minuteness. The theory has heretofore concerned itself mainly with the study of one special form of corpuscle, which is exceedingly prominent in sub-atomic phenomena, and which appears to constitute a sort of basic and omnipresent structural element in the architecture of material atoms of all kinds, inasmuch as it has identically the same properties in every respect, whatever the kind of matter from which it is obtained. These fundamental corpuscles usually occur in combination with structural elements of other kinds to form the atoms, but they are also capable of existing in the free state, and they can be isolated by suitable experimental means. Each corpuscle carries a certain definite and constant charge of negative electricity, which is the same for all of them; and many authorities believe that the corpuscles are, in fact, mere isolated, disembodied electric charges. Whether this be so or not, experimental evidence indicates that the charge associated with a corpuscle has one definite value, and that it is incapable of variation. An atom is supposed to consist of a certain number of these negative corpuscles, associated in some definite way with a positively-

electrified nucleus,—there being, normally, just enough of the negative corpuscles present to neutralize the effects of the positive electrification of the nucleus. According to this view, bodies acquire positive charges by losing some of their negative corpuscles, and acquire negative charges by picking up additional negative corpuscles. If this hypothesis be correct, it is evident that communicating an electric charge to a body is not a continuous process. It is, on the other hand, essentially discontinuous, and consists in adding to the body (or subtracting from it) a number of definite (though exceedingly small) units of electricity,—being roughly analogous to filling (or emptying) a barrel by means of a bucket, instead of by the use of a hose. Moreover, the belief that the charging process is essentially discontinuous is no longer based upon theory alone, for Millikan has obtained direct experimental evidence of such discontinuity, in connection with charges communicated to oil drops by friction.

It happens that the investigation of the positive nucleus of the atom is more difficult than the investigation of the negative corpuscles that are normally associated with this nucleus,—or perhaps it would be more accurate to say that the experimental methods thus far devised are mainly applicable to the study of the negative corpuscle. Under certain circumstances atoms can lose positive charges as well as losing or gaining negative ones; but the loss of a positive charge appears to involve a fundamental change of some kind in the nature of the atom. (See MOLECULAR THEORY.) That there is probably an exceedingly important difference between positive and negative electricity is plainly indicated by the fact that no positive charge has yet been demonstrably observed in connection with a mass smaller than that of the hydrogen atom, while negative charges (as will presently appear) are known to occur in connection with masses far more minute than this.

The definite charge carried by the negative corpuscle appears to be identical in magnitude with the charge carried by the hydrogen ion (or any other monovalent ion), in electrolysis. For this charge Dr. G. Johnstone Stoney, as long ago as 1891, proposed the name "electron" (Lord Kelvin preferred "electron," but his suggestion has not been followed); and this name has been applied quite generally, in recent years, to the negative corpuscles themselves, instead of being restricted to the electric charges that they bear. Present practice among authoritative writers, however, is toward the restoration of the word "electron" to its original sense as the name of a definite quantity (or unit) of electricity, and toward the adoption of J. J. Thomson's original name, "corpuscle" or "negative corpuscle," for the actual particle that bears (or consists of) a charge of one electron of negative electricity. In the present article we shall follow the tendency here noted, and shall call the particle itself a "corpuscle" or "negative corpuscle," and the charge that it bears an "electron" or "negative electron."

The corpuscular theory of matter has been developed in many directions, and its bearing upon the varied phenomena of physics has been extensively investigated by both mathematical and experimental methods. To indicate all its bearings and relations would require a volume,



and the present article will therefore be devoted to an explanation of the origin of the corpuscular theory, and to an account of the numerical results that have been obtained in studying the mass, charge, speed and size of the negative corpuscle. Further data concerning the application of the corpuscular theory to specific physical phenomena may be had from the references given below.

The corpuscular theory of matter, in its modern sense, originated in connection with the study of the discharge of electricity through rarefied gases. Previous to the experimental investigation of this subject it was customary to regard positive and negative electricity as being of the same general nature, but differing from each other somewhat as a right-handed helix or spiral differs from a left-handed one, or (more accurately) as a positive number differs from a negative one. The study of vacuum-tube phenomena indicated, however, that there is a far more profound difference than this between the two kinds of electricity. It was shown by the researches of Plücker, Hittorf, Crookes and others that when electricity is passed through a tube containing air or any other gas in an extremely rarefied condition, the discharge from the negative electrode (or "cathode") is wholly different from the discharge that takes place at the positive electrode (or "anode"). The negative discharge (when the vacuum in the tube is high enough) takes place along straight lines that are everywhere at right angles to the surface of the cathode from which they proceed, and the phenomena observed at the positive electrode are altogether different and far less striking.

The negative discharge that proceeds from the cathode (or negative electrode) at right angles to its surface, in a "vacuum tube," is called the "cathode ray," and special attention was naturally paid to this ray, in an effort to discover its nature. The most strikingly obvious fact about it is, that it excites a vivid fluorescence in the glass wall of the tube, where it strikes it. Hittorf, in 1869, showed that a solid object, placed in the course of the ray, intercepts it and casts a shadow, its outline being plainly visible because there is no fluorescence on the part of the tube that is shielded by the obstacle. Crookes, following Hittorf, took up the study of vacuum phenomena in a fascinating and masterly way and obtained many results that were not only beautiful and striking, but also exceedingly suggestive and stimulating to further inquiry. By placing a very light paddle-wheel in the tube, so that its paddles were within the cathode stream (or ray) on one side, and out of it on the other side, he obtained mechanical rotatory effects. By giving the negative electrode a concave form, and thereby bringing the cathode ray to a focus at a point within the tube, he showed that marked heating effects could be produced by it. These phenomena, together with many others that were observed, suggested that the cathode ray consists of a stream of material particles, negatively electrified by contact with the cathode and then repelled from the cathode on account of the charge they have acquired. This had in fact been strongly urged by Varley (in 1871), and very likely by others also, as it was a fairly obvious inference, though it was not the only explanation possible. (In Germany the

cathode ray was quite generally believed to be due to some form of wave-like disturbance in the ether, and this view was held by Goldstein, who first introduced, in 1876, the name "Kathodenstrahlen," or "cathode rays"). One difficulty was, to identify the nature of the charged particles that were thus repelled. There were reasons for believing that they are not ordinary molecules or atoms. It was known, for example, that when an electrically-charged liquid is evaporated, the vapor does not carry away the electrical charge with it, and this appeared to indicate that the individual atoms or molecules of a gas cannot be separately electrified. Moreover, if the cathode ray consists merely of electrified molecules, it was hard to understand why the effects that were observed in connection with the cathode were not also manifested in connection with the *anode*, or positive electrode. Crookes, as a result of his researches, concluded that the projectile theory (or charged-particle theory) of the cathode ray is correct, but as he fully realized the difficulties in the way of that theory, he announced his belief that in vacuum-tube phenomena we are dealing with matter in a previously unknown state, which he called the "radiant state." It is fair to say that his views appeared to physicists in general as rather too mystical, though the eminence and ability of their author ensured them a respectful reception.

Following the experiments of Crookes there was a lull in the activity with which the phenomena of vacuum tubes were studied, but intense interest in the subject was again aroused by two exceedingly striking discoveries. Lenard, in 1894, showed that the cathode ray can be made to emerge from the tube and pass into the outside air of the laboratory, if a "window" of very thin aluminum (instead of glass) is provided at the point at which the cathode ray strikes the tube. Two years later (namely in 1896) Röntgen discovered that a previously unknown form of radiation is emitted from the point at which the cathode ray strikes against the tube, or against any other solid obstacle. The prospective usefulness of the Röntgen rays (or "X-rays") to the surgeon gave them an intense practical interest, in addition to the interest that they had for purely physical reasons; and from this time onward the study of the electric discharge was prosecuted with renewed vigor and earnestness, and by a large number of physicists—further stimulation being presently added by the discovery of radioactivity (1896) and of polonium and radium (1898). Exceedingly prominent among the physicists who took up the study of the cathode discharge at about this time was Sir J. J. Thomson. Beginning his researches by investigating the general phenomena attending the passage of electricity through gases, and guided by a wonderful scientific imagination, supplemented by a profound knowledge of mathematics and marked experimental skill, he established the soundness of Crookes' views, generalized them amazingly, developed a new "corpuscular theory" of matter and placed that theory on a firm foundation.

It is not possible, in the present article, to give more than a superficial idea of the way in which the reality and general properties of the negative corpuscle have been established. The strength of the corpuscular theory lies in the

fact that it has been tested from many angles, and that the results obtained by approaching it from the most diverse viewpoints have, in the main, harmonized with one another astonishingly. Doubts that may be felt with regard to the legitimacy of the assumptions made in any one line of investigation tend to lose their force when confronted by cumulative evidence from widely different sources. It is true that inconsistencies and other difficulties have developed here and there in connection with the corpuscular theory, but that could only be expected, because the entire subject is still new, and progress in the application of the theory has doubtless been retarded and distorted to a considerable extent by the persistence of certain of our older conceptions and postulates that are no longer defensible, but to which we still cling because we have not yet learned wherein our error lies. In the main, the data that have been obtained are singularly consistent. Moreover, the corpuscular theory has proved to be extraordinarily rich in its suggestiveness, and has led to many lines of investigation that have been fruitful and productive of good results. This alone would justify us in following it still further, to see where it will ultimately lead.

Prominent among the quantities that we should like to determine in connection with the negative corpuscles of which we may for the time being assume the cathode ray to consist, are the following: (1) The mass ( $m$ ) of a corpuscle, (2) the electric charge ( $e$ ) that it bears, and (3) the speed ( $u$ ) with which the corpuscle is moving under given conditions. Let us see how these magnitudes were first obtained:

It has long been known, from the general theory of electricity, that a charged particle, when moving in a magnetic field and at right angles to the lines of magnetic force, is deflected so that it tends to describe a circular arc (instead of a straight line), in a plane perpendicular to the direction of the magnetic lines. It is, in fact, a simple matter to show that when the charged particle is moving freely in space, its charge per unit of mass (denoted in symbols

by the ratio  $\frac{e}{m}$ ) bears to its velocity the same

ratio that the reciprocal of the radius of the circle in which it moves bears to the intensity of the magnetic field that causes the path to be circular. Now it is easy enough to subject the cathode ray to the action of a magnetic field, and the deflection of the cathode ray thus produced is quite marked even when the field is not very strong. The radius of the circular arc that is described by the ray in a field of known strength is also measurable without any special difficulty, and hence we can determine, with a

fair degree of precision, the ratio of  $\frac{e}{m}$  to  $u$ .

This, however, is only one step in the solution of the problem, for we do not yet know either  $\frac{e}{m}$  or  $u$ , separately. Some experimenters,

assuming that the ratio  $\frac{e}{m}$  of the charge on the particle to the mass of the particle is the same in the cathode ray as it is in the case of

the ions that are involved in electrolysis, substituted this value and then proceeded to determine, by means of the experiment just cited, the value of  $u$ ,—that is, the speed of the particles in the cathode ray. By this means a value of  $u$  was obtained that was not greatly different from the speeds "appropriate to atoms of matter." This result was illusory, however,

because the fundamental assumption that  $\frac{e}{m}$  is the same in the cathode beam as it is in electrolysis was wholly gratuitous, and was also, as the event proved, entirely wrong.

Wiechert succeeded in measuring the speed of the cathode-ray particles directly, by means of an exceedingly ingenious apparatus, which, although it is apparently incapable of giving results of any high order of precision, is at least competent to show the order of magnitude of the speed, and hence to check the validity of assuming that it is similar to the ordinary molecular speed, or that the ratio  $\frac{e}{m}$  in the cathode-ray particles is the same as it is in the ions that are concerned in electrolysis. His method depends upon the deflection of the cathode ray by a magnetic field, but he used two magnetizing coils, energized by a rapidly alternating current having a period commensurate with the time required by the cathode-ray particles to traverse a considerable length of the tube. The cathode was placed at one end of the tube and at the other end was a fluorescent screen, which, by its luminosity, showed where the ray came in contact with it. Between the cathode and the fluorescent screen two diaphragms were placed, so that the ray was wholly intercepted except for a small part that could pass through a central perforation in each diaphragm. The first magnetizing coil was placed between the cathode and the first diaphragm, and as the alternating magnetic field that it produced varied, the cathode ray vibrated to and fro across the surface of the first diaphragm. The apparatus was so adjusted that the ray passed through the opening in this diaphragm only when the magnetic field produced by the coil was at its maximum in one particular phase—the oscillating beam being then at the extreme end of (say) its upward swing. At this moment the ray would pass through the opening in the first diaphragm, proceed down the tube to the second diaphragm, pass through the central opening in this, and then register itself by producing a round, luminous spot in a fixed position on the fluorescent screen beyond—the alterations in the magnetic field being so rapid that the spot appeared steady, although the illumination was really intermittent, because the cathode ray, since it could pass the first diaphragm only when at the extreme upward part of its periodic sway, traveled down the tube in a series of spurts or pulsations. The second magnetizing coil was placed at or just beyond the second diaphragm, and in the absence of a certain special adjustment or relation (to which we shall presently refer) the alternating magnetic field produced by this second coil, acting upon the cathode ray as it passed the second diaphragm, would again deflect it, and cause it to impinge upon the fluorescent screen above or

below the spot at which it would strike if the second coil were absent or inactive. It is evident, however, that if the magnetic field of the second coil were always in the zero phase when the cathode-ray pulsation reached it, there would be no second deflection produced, and the luminous spot on the screen would occupy the same position that it would have if the second coil were absent. With the apparatus disposed as described, it was known that the magnetic field of the first coil was at its maximum phase when the cathode ray passed through the first diaphragm, and (if the second coil did not displace the luminous spot on the screen) it was also known that the magnetic field of the second coil was at its zero phase when the cathode-ray pulsation reached the second diaphragm. In performing the actual experiment the two magnetizing coils were made identically alike and were placed in the circuit in parallel and with symmetrically-arranged leads, so that the phase of the current at any given instant would be the same in each. The magnetizing current was furnished by a modified Tesla high-frequency coil, provided with a pair of condensers of known capacity; and from the known electrical constants the frequency of the magnetic oscillations in the two fields could be calculated. The experiment then consisted in determining the shortest distance by which the two magnetizing coils could be separated, consistently with the second one having no effect. (We say the "shortest distance" because it is evident from the nature of wave-motion that a similar zero effect would be observed whenever the time of transit of the cathode ray from one field to the other happened to be one-fourth, three-fourths, five-fourths or any *odd* number of fourths, of the time of a complete period of the current in the magnetizing coils). In one experiment this least distance was found to be 39 centimeters, and the number of complete oscillations of the magnetic field, from either coil, was found to be 32,000,000 per second. Hence the time required for the cathode beam to travel 39 centimeters, in this case, was the 128,000,000th part of a second. Therefore its speed was 4,992,000,000 centimeters per second — or, to express it in the usual way, and to as high a degree of precision as the data will warrant,  $5.0 \times 10^9$  centimeters per second. (The symbol  $10^9$  stands for the ninth power of 10. In the same way  $10^{-9}$  stands for the *reciprocal* of the ninth power of 10. A notation of this kind is in common use in physics for expressing large numbers, as it avoids the use of long rows of ciphers, which are not only confusing to the eye but are also likely to lead to error from misreading, or from the accidental addition or omission of ciphers in copying or printing). It is evident from the foregoing result that the speed of the cathode-ray corpuscles is of an entirely different order of magnitude from the usual speed of translation of gas molecules. The average molecular speed in hydrogen gas, for example, at atmospheric pressure and at the temperature of melting ice, is only about  $17 \times 10^4$  centimeters per second. On the other hand, the velocity of light, in a vacuum, is about  $3 \times 10^{10}$  centimeters per second, so that the velocity of the cathode-ray particles, in this experiment, was about one-sixth of that of light, or about 30,000 times as

great as the speed of translation of hydrogen molecules. It should be understood that no great degree of accuracy is claimed for the particular numerical result just quoted, and it should also be understood that the speed of the cathode-ray particles varies considerably with the degree of exhaustion in the tube, and with the intensity of the electric field in the vicinity of the cathode. It is evident, however, (1) that we are here dealing with speeds entirely transcending anything previously known in connection with the translatory motion of matter, and (2) that Crookes was in all probability right when he expressed the view that cathode-ray phenomena bring us in touch with matter (if indeed these particles are "matter" in the ordinary sense) in a very different state from any with which we have had previous experience.

As might be expected, a large number of experimenters turned their attention to the investigation of the nature and properties of these cathode-ray particles or negative corpuscles, and many exceedingly difficult, beautiful and ingenious lines of research were carried out in this direction. One of the most interesting was Sir J. J. Thompson's determination of the speed of translation of the corpuscles in the cathode ray, by a method wholly different from that of Wiechert. By the aid of a magnet he deflected the cathode stream so that for a definite time it entered an insulated hollow vessel that was connected with an electrometer, which served to measure the aggregate electrical charge of the entering corpuscles. Inside the vessel the beam impinged upon a delicate thermoelectric couple of known thermal capacity, by means of which the total kinetic energy of the torrent of corpuscles could be determined (in the form of heat). The curvature of the beam, outside the closed vessel and under the influence of the magnetic field, was observed at the same time. If  $N$  is the number of corpuscles entering the closed vessel in a given time, and  $e$  is the negative electrical charge on each one of them, then  $Ne$  is the total aggregate charge on all the  $N$  corpuscles taken together. This was one of the quantities measured. Let us represent it by  $Q$  and write  $Q = Ne$ . Again, if  $u$  is the velocity of the particles (assumed to be the same for all) and  $m$  is the mass of any one of them, the kinetic energy of each corpuscle will be  $\frac{1}{2}mu^2$ , and the total aggregate kinetic energy of the  $N$  corpuscles that entered the enclosure will be  $\frac{1}{2}Nmu^2$ . This quantity, which we will denote by  $W$  (so that  $W = \frac{1}{2}Nmu^2$ ), was given by the thermoelectric couple. Finally, if  $H$  is the intensity of the magnetic field (in electromagnetic units) and  $r$  is the radius of curvature of the cathode beam where it traverses this field, we have, from general electrical principles, the relation  $mu = Her$ . We find that it is possible, from these three equations, to eliminate  $N$  and to find the values of  $u$  and  $\frac{e}{m}$ , respectively. In fact, we

have  $u = \frac{2W}{QHr}$  and  $\frac{e}{m} = \frac{2W}{QH^2r^2}$ . When the experiment was performed and the observed values of the measured quantities were substituted on the right-hand side of each equation, the value of the speed,  $u$ , proved to be about 10,000 miles

(or  $1.6 \times 10^9$  centimeters) per second. The value simultaneously found for  $\frac{e}{m}$  (or the electrical charge of a corpuscle, per unit of its mass) was about  $10^7$ , the mass being supposed to be measured in grammes, and the electric charge expressed in absolute electromagnetic units. According to this result, the charge of the negative corpuscle, per unit of mass, is about the thousandth part of the charge observed on the hydrogen atom, per unit of mass in ordinary electrolysis.

It was, of course, highly important to confirm these extraordinary results in as many ways as possible. Another method that suggested itself for determining the speed of cathode-ray corpuscles depends upon the fact that a static electric field tends to deflect a moving electrified particle and cause it to describe a curved arc—circular or parabolic, according to the conditions of the experiment. By subjecting the cathode ray, simultaneously, to a static electric field of intensity  $E$  and to a magnetic field of intensity  $H$ , it is possible, if the directions of the lines of force are properly chosen, and the respective intensities  $H$  and  $E$  are properly related, to cause the two fields to neutralize each other, so far as the deflection of the cathode ray is concerned. An application of the principles of theoretical electricity shows that if the deflection of the ray is to be zero, the two fields acting on its particles must fulfil the relation

$$E = Hu,$$

from which we obtain the very simple result,

$$u = \frac{E}{H}.$$

In other words, if we find, by experiment, a combined magnetic and electrostatic field in which the cathode ray remains sensibly straight, the velocity of the particles of the ray may be found at once by merely dividing the strength of the observed magnetic field by the strength of the observed electric field. The actual application of this method involves special difficulties, but J. J. Thomson overcame them all, and obtained numerical results indicating that the velocity  $u$  lay between  $3 \times 10^9$  and  $2 \times 10^9$  centimeters per second; and this, combined with the result obtained by applying the equation  $mu = Her$ , which holds when the magnetic field acts alone ( $r$  being then the radius of curvature of the cathode ray), led to the further conclusion that the value of  $\frac{e}{m}$  lies between

$0.7 \times 10^7$  and  $0.9 \times 10^7$ , if  $m$  is measured in grammes and  $e$  in absolute electromagnetic units.

It should not be inferred that all our information with regard to the negative corpuscle is obtained from the study of the cathode ray, because this is far from being the case. According to the views at present held, the negative corpuscle plays a leading part in many physical phenomena, and the study of various other departments of physics has led to confirmatory conclusions with regard to the properties of these corpuscles. The Zeeman effect, for example, affords a means of determining

the ratio  $\frac{e}{m}$ , and gives results that are in

harmony with determinations obtained from the cathode ray. The Zeeman effect, in its simplest form, consists in the doubling of the spectral lines of substances, when the radiating source, from which the light giving the spectrum proceeds, is subjected to the action of a powerful magnetic field, in which the lines of force are parallel to the direction of radiation. There is much to be done in the way of clearing up our ideas of the mechanism by which radiation is effected (see RADIATION and MOLECULAR THEORY), but for the moment let us assume that light-waves originate in the disturbances produced in the ether by negative corpuscles executing orbital motions within the atoms of the radiating substance. The planes in which the corpuscles perform these orbital motions will, in general, be distributed equally in all possible positions, and the projections of their orbits upon any selected fundamental reference plane will be described, by the corresponding projections of the corpuscles themselves, equally in a clockwise and a counter-clockwise direction. Now if the radiating source be subjected to a strong magnetic field, the lines of force of which are parallel to the direction of the ray under consideration, the speed of the respective corpuscles will be differently affected, according as their projections are revolving clockwise or counter-clockwise, in their orbits as projected upon a plane perpendicular to the lines of force. Those that are revolving in one direction will be accelerated and those that are revolving in the opposite direction will be retarded, in accordance with known principles in the theory of electricity and magnetism. But a difference in the periods of revolution of the corpuscles will mean a difference in the wavelength of the emitted light, and hence if the magnetic field is sufficiently intense, it will cause a visible separation of the spectral lines into doublets. Lorentz, basing his calculation upon considerations of this kind, has shown that if  $T$  is the original period of the undisturbed vibration causing any given spectral line, and  $t$  is the difference in period corresponding to the two components into which the line is resolved by means of the magnetic field, we have

$$t = \frac{e}{m} \frac{HT^2}{4\pi}$$

where  $e$ ,  $m$  and  $H$  have the same significance as above, and  $\pi = 3.14159$ . . . . With the exception of  $e$  and  $m$ , all these quantities are either known or obtainable by direct observation; and hence the equation affords us an independent means of determining the ratio of  $e$  to  $m$ . Upon performing the experiment Zeeman

found values of  $\frac{e}{m}$  ranging from  $1.4 \times 10^7$  to

$1.8 \times 10^7$ , which agrees fairly well with the results previously obtained from the study of the cathode ray.

Other methods, based upon the action of ultraviolet light, and upon radioactivity and phenomena of various other kinds, have been used for determining this ratio, and from the general agreement among the results obtained by different methods and different experimenters it has become evident that although the velocity with which the corpuscles move depends upon the circumstances under which they

are liberated or set in motion, the electric charge of a corpuscle per unit of its mass,  $\frac{e}{m}$ , is always the same, no matter what the condition of the corpuscle is, or from what source it is obtained. It is evidence of this kind that has led physicists to conclude that the negative corpuscle is a fundamental and omnipresent constituent of matter of every kind. The best value of  $\frac{e}{m}$  that has been obtained up to the present time is certainly Bucherer's. He found

$$\frac{e}{m} = 1.767 \times 10^{11},$$

if  $m$  is measured in grammes and  $e$  in absolute electromagnetic units. This is believed to be correct to within about one-half of 1 per cent. It applies only to slowly-moving corpuscles, however, because, as we shall presently see, the apparent mass of a corpuscle increases with the speed of the corpuscle, while the charge presumably remains unchanged. (Bucherer's value of  $\frac{e}{m}$  is  $5.299 \times 10^{11}$ , if the electric charge is expressed in absolute electrostatic units.)

The fact that the ratio  $\frac{e}{m}$  is nearly 2,000 times as great as the charge per unit mass observed in connection with the hydrogen atom in electrolysis shows, most conclusively, that one of two things must be true: Either (1) the charge on the negative corpuscle is far greater than the charge accompanying an ion in electrolysis, or (2) the mass of a negative corpuscle is far less than the mass of any ion or atom previously known to us. Of course these may *both* be true, but certainly *one* of them is true, and as soon as this fact was recognized, it was also recognized that the discovery of the negative corpuscle was an event of fundamental importance in the history of physics.

In order to find out which alternative must be adopted, J. J. Thomson undertook to determine the electric charge on a single corpuscle—and hence also the mass of the corpuscle, since the ratio of the two was known. More accurate values of these quantities have since been obtained by other means, but Thomson, it should be remembered, was a pioneer in a new field, and the work that he did in solving his problem has justifiably been called by Sir Oliver Lodge "one of the most brilliant things recently done in experimental physics." We can only outline his method in a rough way. It depends (1) on the fact, discovered by Aitken in 1880, that condensation of aqueous vapor in air does not occur, even when the air is supersaturated, unless there are nuclei of some sort for the mist-particles to form about; (2) on the fact, demonstrated by Lord Kelvin in 1870, that the surface tension of small droplets of water, suspended in the air, tends to cause evaporation even though the degree of saturation is enough to cause condensation on a water-surface that is flat, or that has a large radius of curvature; (3) on the fact, announced by J. J. Thomson himself in 1888, that the electrification of such a drop-

let tends to neutralize the effect of the surface tension, so that condensation can take place on a water droplet, or on any other curved surface of exceedingly short radius, if this droplet or surface is electrified, even though no such condensation could take place in the absence of the electrification; (4) on the investigation, by Sir George Stokes in 1849, of the limiting speed at which small spherical bodies will fall, by their own weight, through a fluid of known viscosity; and (5) on the method devised by Mr. C. T. R. Wilson, in 1887, for precipitating, by adiabatic expansion, a definitely-known quantity of aqueous vapor in the form of mist, from saturated air.

Thomson's experiment consisted (1) in partially ionizing, in a closed vessel and by means of X-rays or ultra-violet light, air containing a suitable quantity of water vapor; (2) in causing the deposition of droplets of mist, by Wilson's method of quick adiabatic expansion, about the ions thus set free; (3) in observing the rate at which the mist thus formed subsides—a process which really consists in the falling of the individual droplets through the air; (4) in calculating, by means of Stokes' formula, the diameter (and subsequently the weight) of the spherical droplets constituting the mist—this being made possible by the fact that he knew the viscosity of the air and had observed the rate of fall of the droplets; (5) in calculating the total mass (or weight) of water precipitated, in accordance with Wilson's method, from the known degree of expansion of the air; and (6) in dividing the total weight of precipitated water by the weight of a single droplet, and thereby determining the number of droplets. The number of droplets produced being assumed to be the same as the number of available ions about which condensation was theoretically possible, the experiment manifestly gave the total number,  $N$ , of the ions present in each cubic centimeter of the air, under the conditions prevailing in the experimental apparatus. In one experiment  $N$  was found to be 30,000.

The total aggregate charge of the ions was determined by means of a pair of parallel metallic plates in the vessel in which the mist was produced—one of them being insulated and connected with an electrometer. If the space between the plates contained positive ions, for example, then by suddenly communicating a strong positive charge to the non-insulated plate these ions could be quickly repelled against the insulated plate, to which they would give up their charges; and the aggregate charge that they were carrying could then be measured by the electrometer. By means of this principle the total charge on the ions in a cubic centimeter of the air in the mist-chamber was determined; and by dividing this total charge by  $N$ , the number of ions in a cubic centimeter of the air, the charge on one individual ion became known.

The charge on each ion was assumed to be due to the excess or defect of one electron, and hence the experiment gave an estimate of the charge,  $e$ , associated with each corpuscle. The value of  $e$  at first obtained by Thomson in this way ranged from  $5.5 \times 10^{-19}$  to  $8.4 \times 10^{-20}$  electrostatic units, and he adopted  $6.5 \times 10^{-20}$  as the concluded value. In 1903 he

published a later determination of  $e$ , obtained by following the same general plan as before but with certain improvements in technique, and gave the value  $e = 3.4 \times 10^{-10}$ .

Beautiful and ingenious as this determination of the charge on the individual corpuscle was, the method was open to certain criticisms, inasmuch as it involved certain assumptions which had not been shown to be valid, and which, in fact, were only approximately true. They were near enough to the truth for the method to yield a rough estimate of the value of  $e$ , but they were too imperfect to provide us with an accurate and dependable determination. It was not known, for example, that Stokes' formula for the rate of fall of spheres in a viscous fluid would apply with sufficient accuracy in the case of droplets of the exceedingly small size here under consideration. Nor was it known that every ion actually did surround itself by a liquid droplet, nor that there were no droplets containing more than one ion. Nor did the method make allowance for the effect of differences in the sizes of the droplets, nor for possible evaporation from their surfaces after they were formed. It is not possible, in the present place, to discuss these various points, but it must suffice to say that they have all received the most careful consideration in later researches, and Prof. R. A. Millikan, of the University of Chicago, has recently been able to publish a definitive and probably very accurate value of  $e$ , obtained by a method which apparently leaves little to be desired on the score of soundness or of experimental excellence. It does not detract in any way from the admiration that we must feel for Thomson's original work, to say that Millikan's research was still more ingenious and beautiful. He succeeded in trapping single corpuscles, and in measuring the value of the "electron" directly; and the account of his work that he gives in his book, 'The Electron,' is extremely fascinating.

Millikan's fundamental idea was exceedingly simple, but in its practical application it called for an immense amount of ingenuity, experimental skill and patient labor. A tiny spherical droplet of oil was electrified and caused to take up a position, suspended in the air, between two horizontal metallic plates that could be electrified or grounded, at will. The drop was strongly illuminated from two opposite sides, and was observed by means of a telescope directed at right angles to the light-rays. It appeared, in the field of the telescope, "like a bright star against a black background." The drop was first allowed to fall freely through a known distance (approximately equal to half a centimeter or one-fifth of an inch), the limits of which were marked by a pair of cross-hairs in the telescope. The time of fall through this distance, in one set of experiments, was about 13 seconds. Before the drop reached the lower metallic plate, both plates were electrified by connecting them to the terminals of a battery having a total electromotive force of from 5,000 to 10,000 volts, the charge of the lower plate having the same sign as the electrification on the oil drop. When the experiment was rightly conducted, the drop (already carrying an electric charge) would begin to rise, under the influence of the electric field to

which it was exposed, and the time required for it to make its upward journey from the lower cross-hair of the telescope to the upper one was noted. Before it reached the upper plate the electric field would be destroyed by grounding the metal plates. The drop would then fall again, and the time of its descent from the upper cross-hair to the lower one was once more observed, and so the experiment proceeded—keeping the droplet always in the air, and continually recording the times of its ascent and descent. (A single drop could thus be kept under constant observation for hours.) The size of the drop was determined from the measured time of its fall by means of a modified form of Stokes' formula for the descent of small spheres in viscous media—the original formula having been studied with great care (especially by Dr. H. D. Arnold) with reference to its accuracy in connection with droplets of the size used in these experiments. The diameter of the droplet being known, its weight was readily ascertained, because the density of the oil of which it was composed was known. Then from a knowledge of the weight of the drop, and of the time of its downward passage under the influence of gravity and of its upward passage under the influence of the known electric field, it was easy to calculate the electric charge on the drop. An ingenious means was provided for changing the electrification of the drop at will, and in either direction, by ionizing the air between the plates by means of an X-ray discharge, and then throwing ions against the drop by electric repulsion. The original positive electrification of the drop was reduced every time a negative ion was taken in, and increased every time a positive ion was received. After a positive ion had been taken in, the upward journey would be performed more quickly than before, and the inclusion of a negative ion would cause a corresponding slowing of the upward motion. It was found to be quite possible to determine, from the circumstances of the motion, the number (as well as the sign) of the ions thus entering the drop; and by calculating the electric charges for all the different upward journeys that were observed, it became evident that these various charges either showed no change, or differed from one another either by a certain constant quantity, or by a low multiple of that quantity. It was even found that the original charge of the droplet was also an apparently exact multiple of this same quantity. The doctrine that electrification is a discontinuous process, and that it consists in adding to a body (or subtracting from it) a certain number of small-sized yet finite and equal charges, or "electrons," thereby received an exceedingly striking and definite confirmation; and the data available made it quite easy to calculate the magnitude of this elementary unit charge. After several years of study and observation, culminating in two years of work with a special apparatus constructed with exceeding care, the final conclusion was, that the charge on the electron is invariably  $e = 4.774 \times 10^{-10}$  absolute electrostatic units; and Millikan believes (apparently with good grounds) that the uncertainty in this result is not greater than the thousandth part of its own magnitude. (The

corresponding value of the charge, in absolute electromagnetic units is  $e = 1.592 \times 10^{-20}$ ).

Millikan obtained his oil drop by perforating the upper of the two metallic plates by means of a minute pinhole, and then sending a fine spray of the oil into the space above the plate, by blowing a puff of air through an atomizer. In the course of time one of the droplets of the spray would fall through the pinhole into the region between the plates, and the experiment could be started. The friction to which the oil was subjected in the atomizer electrified the droplets of spray positively, and, as has been stated above, the charge communicated to the droplet in this way was always found to be an exact multiple of the value given above. This fact is highly interesting, because here we have, for the first time, direct evidence that an electric charge communicated to a body by friction consists in an excess or deficit of a definite, finite number of electrons. In one experiment, for example, the positive charge communicated to the droplet by the initial friction of the atomizer was found to correspond to a loss (or deficiency) of nine negative electrons.

Millikan varied his drop-experiments in many ways, using numerous substances (including mercury) for the drops, and experimenting with drops of widely different sizes, and with various gases between his electrified plates; and he concludes that "the apparent value of the electron is not in general a function of the gas in which the particle falls, of the materials used, or of the radius of the drop on which it is caught." In other words, he strikingly confirmed the theory that the negative corpuscle has an actual, physical existence, apart from the existence of the kinds of matter heretofore contemplated by the chemist.

The determination of the mass  $m$  of a free, slowly-moving negative corpuscle is an easy

matter after  $\frac{e}{m}$  and  $e$  have been separately determined; for we have the simple relation  $e + \left(\frac{e}{m}\right) = m$ . With Millikan's value of  $e$  and

Bucherer's value of  $\frac{e}{m}$  (both expressed in terms of absolute electrostatic units) we have  $m = (4.774 \times 10^{-20}) + (5.299 \times 10^{21}) = 0.901 \times 10^{-27}$  grammes.

(It may be shown, from this, that it would require 1,845 slowly-moving negative corpuscles, to have a combined mass equal to the mass of one hydrogen atom.)

We do not yet know the *shape* of the negative corpuscle, nor do we positively know that the word "shape" has any definite meaning when applied to it. Larmor, for purposes of discussion, assumed the corpuscle to be a mathematical point endowed with a finite charge of electricity, which creates a certain type of strain in the surrounding ether; but the prevailing conception (in which Larmor would doubtless concur) is that the actual, physical corpuscle has some kind of spatial extension, though it may not have definite boundaries. Nicholson, in a paper read before the Physical Society of London in October 1917, suggested that the corpuscle is a region of strain in the ether, the strain being intense in the immediate

vicinity of a certain central point, and diminishing with extreme rapidity as we pass away from that point. According to this view the corpuscle would have no definite boundaries, and therefore (in a strict sense) no definite shape, though on account of the intense localization of the region in which the strain is really significant, we might treat the corpuscle for most purposes almost as though it were a mathematical point. If we desired to assign a "radius" to such a corpuscle, we should have to define the radius arbitrarily, either as extending to a region where the strain is some definite fraction of the maximum central strain, or in some other way.

In the absence of data concerning the shape of the negative corpuscle, it is natural to try, first, the simplest assumption we can make with regard to it and to see how well this fits such facts as we have. The simplest shape, from a mathematical standpoint, is a sphere; and we find that the three best-known theories as to the shape of the negative corpuscle assume it to be spherical, at all events when it is at rest.

(1) Abraham considers the corpuscle to be rigid and spherical at all times, whether it is moving rapidly or at rest.

(2) Lorentz considers it to be spherical when at rest, but assumes that when it moves it becomes transformed into an ellipsoid of revolution with its equatorial radius unchanged, but with its polar radius (which is parallel to the direction of the motion) shortened to  $r\sqrt{1-x^2}$  where  $r$  is the original radius and  $x$  is the ratio that the speed of the corpuscle bears to the speed of light.

(3) Bucherer and Langevin also consider the corpuscle to be spherical when at rest and assume that when it is in motion it takes the form of an ellipsoid of revolution with its polar radius shortened and directed parallel to the motion; but they assume that the polar radius becomes  $r(1-x^2)^{\frac{1}{2}}$  and that the equatorial radii are *increased* in consequence of the motion, so that each becomes equal to  $r(1-x^2)^{-\frac{1}{2}}$ , where  $r$  and  $x$  have the same significance as before. (It is to be observed that these relations of Bucherer and Langevin leave the *volume* of the corpuscle unchanged, whatever the speed may be).

Each of these conceptions has something in its favor, and each has something against it, but they should all be regarded merely as convenient mathematical fictions for the present—fictions that are worth considering because they may serve to suggest further researches when their consequences are investigated. The experiments of Kaufmann (to which reference will presently be made) appear to be incompatible with Lorentz's conception of the corpuscle, while the theory of relativity suggests that those of Abraham and of Bucherer and Langevin are untenable.

The general theory of electricity, as applied to static charges moving rapidly through space, brings us face to face with an exceedingly interesting topic in connection with the negative corpuscle,—namely, that its apparent mass is doubtless in some measure of electrical origin, and that it is quite within the bounds of possibility that it is wholly electrical. Sir J. J. Thomson pointed out, as long ago as 1881, that a moving body (for example, a sphere) pos-

sesses a somewhat greater apparent inertia, or mass, when it is electrically charged than it does when it is not charged. ('Recent Researches in Electricity and Magnetism,' p. 21.) This is due to the fact that the charged body has Faraday "tubes of force" radiating from it, and these tubes are supposed to carry a certain amount of ether along with them and to encounter a sort of hydrodynamic resistance from the surrounding ether. This resistance is not analogous to friction, however. It does not necessarily entail any dissipation of energy, but has the general effect (when considered mathematically) of increasing the apparent mass of the charged body. Thomson showed, for example, that a sphere having a radius of  $r$  centimeters, and bearing an electric charge of  $e$  absolute electromagnetic units, has an apparent mass equal to  $\left(m + \frac{2}{3} \cdot \frac{e^2}{r}\right)$  grammes, if it is stationary or moving with a speed that is small in comparison with the speed of light;  $m$  being its mass, in grammes, when the electric charge is absent.

When a charged sphere is caused to move with greater and greater speed, the Faraday tubes of force shift their positions in relation to it, and Heaviside showed (in 1889) that as the speed increases, each tube, whatever its original direction, will be displaced more and more toward a plane passing through the centre of the sphere perpendicularly to the line of motion. In other words, if we call the diameter that coincides with the direction of motion of the sphere its "polar axis," the tubes of force that radiate from the sphere will crowd closer and closer toward the equatorial plane, the faster the sphere moves. Moreover, the shifting of each tube (according to Heaviside's analysis) will take place in such a way that the original distance of every point in the tube from the equatorial plane will be reduced by the motion in the proportion of  $\sqrt{V^2 - v^2}$  to  $V$ , where  $v$  is the speed of the sphere, and  $V$  is the speed of light. (It is to be observed, in particular, that the tubes approach the equatorial plane in the same way, whether they lie in front of it or behind it, as the sphere moves through space).

Now the effect of the ether upon a Faraday tube is very different when the tube is moving *endwise* than when the tube is moving *side-wise* (or perpendicularly to its own length); and in consequence of this fact, the part of the apparent mass that is due to the electrification increases when the speed of the sphere becomes great enough for the equatorial crowding of the tubes of force to become significant. It is not possible to deal with this phase of the subject more than superficially in the present article, but it should be specially noted that mathematical analysis has shown (1) that owing to the existence of the Faraday tubes of force that stretch out into the ether from an electrified body, that body, whether its charge be positive or negative and whether it be stationary or in motion, has an apparent mass greater than the mass it has when the charge is absent; (2) that owing to the crowding of the Faraday tubes toward the equatorial region when the speed of the body increases, the apparent mass of the body increases as the speed increases; (3) that at any ordinary speed this increase in apparent

mass is insignificant and does not have to be reckoned with; but (4) that it becomes significant as soon as the body attains a speed equal to a few tenths of the speed of light, and (5) the apparent mass increases with extreme rapidity as the speed approaches closely to the speed of light, and (6) it would become infinite if that speed were fully attained.

Now until the last few years this rather striking conclusion was of academic interest only and it had no practical bearing because we could not produce any such prodigious speeds, in electrified bodies, as were necessary in order to give rise to any sensible increase in their apparent mass. When, however, it was discovered that the negative corpuscles in high vacuum tubes are moving with speeds comparable with (though always materially less than) the speed of light, the conclusions summarized above began to have an important practical bearing and physicists asked themselves whether any increase in the apparent mass of these corpuscles could be detected, that could be assigned to the causes indicated—that is, whether any experimental evidence could be adduced, to show that the apparent mass of a swiftly-moving electrified particle increases with the speed with which the particle is traveling. The question became far more interesting and important when it was shown that the so-called "beta rays" emitted by radium are identical with the negatively electrified corpuscles observed in vacuum tubes, because the speed of these beta particles has been found to be as high as from 95 to 97 per cent. of that of light in some cases, and hence they should show a marked increase of apparent mass, if the previous theoretical conclusions about the effect of speed upon mass were sound.

Partly with the object of testing this point, and partly with the broader idea of gaining a general insight into the nature of mass and inertia and into the constitution of the negative corpuscle, W. Kaufmann, of Göttingen, undertook to determine the ratio of charge to mass for these rapidly-moving particles, at various speeds. An interesting semi-popular account of his best-known experiments will be found in Sir Oliver Lodge's 'Electrons.' (For the original papers, see *Comptes rendus*, 13 Oct. 1902; *Physikalische Zeitschrift*, 4, 1902-03, p. 55; *Annalen der Physik*, Vol. XIX, 1906). The method employed by Kaufmann was a modification of the one outlined above for determining the speed of cathode-ray corpuscles by subjecting the particles simultaneously to magnetic and electrostatic fields of force, except that Kaufmann made use of a stream of beta particles, emitted by radium, and arranged his apparatus so that the magnetic field tended to deflect each corpuscle toward (say) the north, while the electric field, instead of being disposed so as to neutralize this effect, was arranged so that it tended to deflect the corpuscle (say) toward the east. The stream of beta particles impinged against a photographic plate in such a way that a small, round, single spot was registered upon it when neither field was active. When the magnetic field alone was excited, the spot would have been merely displaced toward the north if the beta particles all had the same speed; but inasmuch as they had a great variety of speeds, it was drawn out into a straight line, extending in a north-and-



south direction. Similarly, the electric field, when acting alone, caused it to be drawn out into a straight line extending in an east-and-west direction. In the actual experiment, with both fields acting at once, the line that was observed was a curve; and from a study of the shape and position of this curve it was found to be possible to determine, separately, the velocity,  $u$ , of the particles impinging upon any given part of it, and the ratio  $\frac{e}{m}$  for these

same particles. If it is assumed (in accordance with all the other evidence that we have) that  $e$  remains invariable, the data thus obtained show the relation between the mass,  $m$ , of a negative particle and the speed,  $u$ , with which the particle is moving.

The relation between speed and mass, as revealed by these experiments, was very marked. For example, at the highest speed observed (which was about 97 per cent. of that of light) the apparent mass of a corpuscle was found to be about three times as great as the mass of the same corpuscle when at rest.

Kaufmann's experiments provide us with means of testing, to a certain extent, theories of the constitution of the negative corpuscle, inasmuch as for every theory concerning the general nature of the corpuscle there will be a corresponding law of variation of mass with speed. This was recognized immediately, and was, in fact, largely what led to the making of the experiments to which we have just referred. A curious fact that has to be reckoned with, in applying tests of this kind to the observational data, is, that every negative-corpuscle theory yet proposed indicates that the mass of a body moving at high speed is a *vector* quantity—that is, that the mass of the body, as measured in the direction of the motion (i.e., the so-called *longitudinal* mass) is different from the mass of the same body as measured at right angles to the direction of the motion (i.e., different from the so-called *transversal* mass). It is the transversal mass, as Abraham pointed out in 1902, with which we have to deal in discussing experiments such as Kaufmann's.

If  $R$  is the ratio that the speed of a given negative corpuscle bears to the speed of light when the electrical part of the transversal mass of the corpuscle is  $m$ , and if  $m_0$  is the electrical part of the mass of this same corpuscle when it is at rest, then for  $m \div m_0$  we have the following values for the respective theories of negative-corpuscle structure mentioned above:

$\frac{3}{4} \cdot \frac{1}{R^2} \left\{ \frac{1+R^2}{2R} \cdot \log \left( \frac{1+R}{1-R} \right) - 1 \right\}$  for the Abraham theory;  $\frac{1}{(1-R^2)^{1/2}}$  for the Lorentz theory; and

$\frac{1}{(1-R^2)^{3/2}}$  for the Bucherer-Langevin theory.

When the several hypotheses as to the constitution of the negative corpuscle are judged by comparing these formulas with Kaufmann's experimental data, it appears (1) that the Lorentz corpuscle, which is the only one of the three that conforms with the theory of relativity, does not fit the data at all well; and (2) that the experimental evidence agrees quite well with either the Abraham or the Bucherer-Langevin corpuscle.

From experiments of this nature we may

obtain a certain amount of information with regard to the proportion of "electrical mass" to "real mass" in a corpuscle; for the experimental data reveal the law in accordance with which the total mass varies with speed, while the theory of the nature and constitution of the corpuscle yields a formula showing merely how the electrical part of the mass varies. If there is a "real mass" to the corpuscle, we may therefore reasonably hope, by comparing experiment with good theory, definitely to solve this question of the quantitative relation between the two kinds of mass. Kaufmann, soon after his original experiments were made, believed that they indicated that only a fraction of the total mass is electric; but he had not then taken account of the difference (noted above) between longitudinal and transversal mass. Later, when due allowance was made for this difference, he came to the conclusion that most and perhaps *all* of the mass is electric; and there is a growing tendency among physicists not only to accept this view with regard to negative corpuscles, but also to generalize it broadly, and to assume (at least tentatively) that mass, wherever it is found, is exclusively electrical in nature, and due to the motion, within the atoms of bodies, of electrified corpuscles moving with great speeds. This conception is as fascinating as it is revolutionary. Many of its advocates, however, overlook the fact that even if this should prove to be the case, we have "explained" mass only by shifting it to the ether, which, at the same time, we should apparently have to conceive as a medium far denser than anything we know of, in the visible and tangible world of direct experience.

Before attempting to estimate the size of a negative corpuscle, it is necessary clearly to understand that we have no way, as yet, to determine the dimensions of corpuscles, if we assume that the mass that they possess is only partially electrical and that the rest of it is mass in the usual or non-electrical sense. If, however, we assume that the mass is wholly of electrical origin, we can easily obtain an estimate of the size of the corpuscle. The value that we obtain will depend in some measure upon the views that we hold with regard to the shape of the corpuscle; but if, for present purposes, we consider it to be spherical, the estimate of size obtained will probably be of the right general order of magnitude, even if the spherical shape ultimately proves to be untenable, so far as concerns the relation of the negative corpuscle to phenomena in general.

To obtain the desired estimate of size (in conformity with the assumptions here outlined) we may make use of the expression given by J. J. Thomson, and already quoted above, for the electrical mass of a slowly-moving electrified sphere. Thus if  $m$  is the mass of the (stationary or slowly-moving) corpuscle in grammes,  $r$  its radius in centimeters and  $e$  its charge in absolute electromagnetic units, we have

$$m = \frac{2}{3} \cdot \frac{e^2}{r}, \text{ or } r = \frac{2}{3} \cdot \frac{e^2}{m}$$

Hence, with the values given above for  $e$  and  $m$ , we have

$$r = \frac{2}{3} \cdot \frac{(1.592 \times 10^{-20})^2}{0.901 \times 10^{-27}} = 1.875 \times 10^{-12} \text{ centimeters}$$

In other words if 10,000,000,000,000 negative

corpuscles were placed in a line and just touching one another, they would make a row about an inch and a half long. (An equal number of oranges, each three inches in diameter and placed in a row in like manner, would reach from the sun to the orbit of Jupiter). Atoms differ in size, but in a rough and general way it may be said that it would require something like 100,000 negative corpuscles, placed in a straight line and in contact with one another, to reach across the diameter of an atom.

The corpuscular theory has developed marvelously in the last 15 years, and it has been applied, in one form or another, to the explanation of the mechanism of many phenomena, such as radiation, X-rays, radioactivity, and electrical and thermal conduction. It has also been pressed into service to explain chemical affinity and valency and to elucidate the structure of atoms and molecules. It has proved to be a fruitful conception, and some modification of it will no doubt remain with us, as a permanent addition to our physical theories. It should be recognized, however, that when, in discussing particles so exceedingly small, we apply the general physical and mechanical laws and principles that we have deduced from observation in our grosser world of experience, we are very likely committing a serious error—an error which, though it will no doubt be corrected in the course of time, may be blinding us, meanwhile, to some very large facts. Many of the "laws" that apply to larger masses of matter are probably statistical laws, due to the averaging of many millions of separate events that do not individually follow these laws. That the properties of the negative corpuscle are far different from those that we have heretofore assigned to "gross" matter is already sufficiently shown by what we have learned about the mass of such corpuscles. In a general way, however, it may be said that we have made progress enough in the study of the negative corpuscle to have it become a real thing to us—or at least a *symbol* of a real thing; and J. J. Thomson has well said that although the negative corpuscle is a recent discovery, we already know more about it than we do about the atom. See also ELECTRICITY; MOLECULAR THEORY; RADIATION; RADIOACTIVITY.

**Bibliography.**—A creditable and interesting popular account of the negative corpuscle and its various relations is given in E. E. Fournier d'Albe's 'Electron Theory,' though the numerical data therein given have now been largely superseded by better values, as indicated in the present article. A more recent and more authoritative review of the relation of the corpuscular theory to physical phenomena in general is given by J. P. Minton in a series of papers printed in *The General Electric Review* for 1915 (Vol. 18.) Consult also Thomson, J. J., 'The Corpuscular Theory of Matter,' 'The Conduction of Electricity through Gases' and 'Electricity and Matter'; Campbell, 'Modern Electrical Theory'; Lodge, 'Electrons'; Larmor, 'Aether and Matter'; Millikan, 'The Electron'; Comstock and Truland, 'The Nature of Matter and Electricity'; Bucherer, 'Mathematische Einführung in die Elektronentheorie'; Abraham, 'Theorie der Elektrizität' (Vol. II).

ALLAN D. RISTEEN, Ph.D.

**ELECTROOPTICS**, a branch of electrical science treating of the relation of electricity to light. See LIGHT.

**ELECTROPHORUS**. See ELECTRIC MACHINE.

**ELECTROPHOTO MICROGRAPHY**, the art of photographing, by means of the electric light, certain objects magnified by the microscope.

**ELECTROPHOTOGRAPHY**. See PHOTOGRAPHY.

**ELECTROPLATING**, the art of plating or covering solid objects with a coating of metal by electro-deposition. This is the most common method of applying silver or gold plate for ornament, or copper or nickel plate, as for rendering an article more durable. Given a solution of the salts of a metal, say, for instance, sulphate of copper (the constituents of which are sulphuric acid and copper oxide), in which are immersed a copper plate connected with the positive pole of a source of electromotive force and a metal plate connected with the negative pole; when an electric current is passed through the solution an action takes place which may be described as follows: First, the salt is decomposed into sulphuric acid and oxide of copper. At the same time a portion of the water of the solution is also decomposed, setting free hydrogen and oxygen. The oxygen of the oxide of copper is drawn to the negative pole, where it unites with a portion of the hydrogen just freed, forming water, and the metallic copper thus set free is deposited uniformly on the negative metal plate. Simultaneously with this action sulphuric acid and oxygen arrive at the positive plate, where the oxygen unites with a particle of the copper plate, forming oxide of copper, with which the sulphuric combines, forming sulphate of copper; which process is continued as long as there is any metal left in the positive plate. For each atom of copper thus dissolved at the positive plate another is set free at the negative plate. Actions analogous to these underlie all electroplating and electrotyping operations. If it is desired to deposit nickel, silver, gold or other metal on the object, salts of those metals instead of copper will be used in the solution or *bath*, as it is termed.

Silver is the easiest metal to use in plating. one ampere of current depositing 4.02 grams of metal per hour; with the same current copper deposits 1.17 and nickel 1.09 grams per hour. If 10 baths are worked in series of eight hours a day, depositing each 10 pounds of copper, they will require 4,830 amperes of current all the time; and with copper anodes the pressure will be about 16 volts for the 10 baths.

The art of electroplating is extensively practised. The current for the decomposition of the electrolyte, in solution, is usually supplied by continuous-current dynamo machines which are specially designed to give large currents at low electromotive force, rarely exceeding three to five volts. Sufficient electromotive force must be provided to decompose the solution, but the amount of chemical decomposition depends altogether on, and is proportional to, the rate or amperage of the current. If too high electromotive force is employed the plating is uneven and granular. Storage or primary batteries may also be used for this purpose.

and are so used for planting on a small scale. Much care and special knowledge is required to obtain the best results in electroplating. The process is begun by thoroughly cleaning, as by pickling and scouring the article to be plated to remove all trace of oxide or other impurity from its surface. In the case, for instance, of gold, silver or nickel plating the bath or solution employed by some electroplaters consists of 100 parts water, 10 of cyanide of potassium and 1 of the cyanide of gold, silver or nickel, as the case may be. Plates of either of these metals are suspended in the bath as the positive pole, while the article to be plated is suspended in the bath as the negative pole. When the plating has proceeded to the desired depth or thickness the articles are taken out and burnished. Such parts of the article as it may not be desired to plate are covered with grease, oil or wax. When non-metallic articles are to be plated they are first given a coating of wax, over which is laid a film of powdered plumbago, upon which the plating then takes place.

**ELECTROPNEUMATIC BLOCK SYSTEM.** See BLOCK SIGNAL SYSTEM.

**ELECTROPOION**, a mixture of sulphuric acid, bichromate of potash and water used as the liquid for batteries in which zinc and carbon are the poles. See ELECTRIC BATTERY.

**ELECTROPYROMETER.** See PYROMETER.

**ELECTROSCOPE**, an instrument for detecting or determining the presence of electricity upon a conductor, and showing whether it is positive or negative. It has many forms, of which the simplest consists of pith balls hanging from silk threads in a dry, closed glass case. On contacting with an electrified body the piths are excited and swing apart. In the gold leaf electrometer there is a wide-mouthed vial stoppered with a cork, through the centre of which a metal rod passes into the middle of the vial. There is a brass knob at the top of this rod and its lower end is bent or hooked to support a narrow strip of gold foil, which is folded in equal lengths over the hook. When a rubbed glass rod is brought near the brass knob, negative electricity is attracted and positive electricity is repelled to the gold leaves, which diverge by reason of the repulsion of the similar electricity on the leaves. To show the kind of electricity with which the leaves are charged, or with which another body may be charged, a finger is placed on the brass knob while yet the glass rod is near it. This allows the positive electricity to escape. When next the finger and then the rod are removed the negative electricity is dispersed over the gold leaf system and the leaves again diverge. If now, while the leaves are charged with negative electricity, a negatively charged rod be brought near the knob, the leaves tend to diverge still farther. If a positively charged rod is used the negative electricity in the leaves is attracted and the leaves tend to collapse.

Electroscopes of this general type are now utilized, on account of their great susceptibility to the presence of electricity, to detect and measure the radioactivity of weakly radiating substances like uranium and thorium, advantage being taken of the ionizing properties of such substances by which the particles of gases become carriers of electric charges proportional

to the radioactivity of the substances. For this purpose the gold leaf system is placed in metallic connection with the upper plate of a small air condenser, on the lower plate of which is spread a layer of the radioactive material. A source of electromotive force is connected with the lower plate and the movement of the gold leaf is noted. As the rate and extent of this movement vary with the radioactivity of the substance, comparisons can be readily made of different substances or with a standard. See ELECTROSTATICS; ELECTROMETER.

**ELECTROSMELTING.** See ELECTRO-CHEMICAL INDUSTRIES.

**ELECTROSTATICS**, that branch of electrical science dealing with electricity at rest, or static; opposed to electrodynamics, which deals with electricity as a force, in action. In the period of early research the electrical phenomena produced by friction came to be called static electricity, and it has been convenient to retain the nomenclature, although it is recognized that all divisional names of electricity are arbitrary, for in all of them we deal with the same unknown thing whose phenomena we observe largely through its high vibrations. The terms free electricity and atmospheric electricity (q.v.) were formerly much used to describe the electricity which we recognize as resident in the air and clouds above us; but to-day the term static electricity is the one most commonly employed to describe that drawn from the atmosphere on a kite-string; or that which accumulates in a pile of printing paper which has been subjected to some frictional contact that causes the sheets to adhere to each other; or to electrification in a driving belt caused by some accidental rubbing in the course of its travel.

The first discoveries regarding electricity were regarding its static qualities. In the handling of amber, which is a fossilized vegetable resin, it was found to display peculiar phenomena when rubbed, attracting light particles of matter. This phenomena came to be called electric, after Greek elektron, the name for amber. Later glass was found to display similar yet opposite phenomena on being rubbed, and there arose the terms "vitreous" and "resinous" electricity, for the sort produced by rubbing glass or amber respectively, and which have since been identified as simply positive and negative electricity. It was also learned that there is always a balance maintained between positive and negative electricity, and that the development of a given amount of one means an equivalent amount of the other. For a fuller description of the development of knowledge regarding frictional electricity which we now call static electricity, see the article on ELECTRIC MACHINE.

An understanding of induction is essential to an appreciation of static electricity. Static induction is the production of an electrical charge upon one body by another body that is statically charged. It might be termed electrical influence.

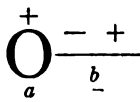

If the circle *a* becomes charged by friction, so that it is positively and electrostatically

charged, as indicated by the sign +, then on being brought near to another body *b*, the near end of *b* will become negatively charged, as indicated by the minus sign —, and the far end positively +. By touching *b* with the finger the electricity may be drawn off, or "earthed" or "grounded," passing through the body of the toucher to the earth if he is not insulated. The electrophorus is the simplest device for illustrating this principle and is described under ELECTRIC MACHINE. But it should be understood that the current producible by a static electric machine does not differ from that of a battery or a dynamo, except that it is naturally and usually much less in quantity, being a primitive form of apparatus. From these early experiments it was demonstrated that every body positively charged repelled another body of positive charge; and any negatively charged body repelled another negatively charged body, while attracting a positively charged body. It was soon apparent, however, that the forces of attraction and repulsion varied greatly when the bodies were exposed in some other medium than the ordinary atmospheric air. The word dielectric was coined to express the material medium in which a body statically charged was located, and the term has been extended by common consent to mean any non-conductor, as glass or mica. A static machine was sometimes termed a dielectric machine, and the transmitting of electric forces by induction instead of conduction was dielectric; while the power of a dielectric to resist stress caused by induction across it, as measured by difference of potential necessary to break through in a violent disruptive discharge, was denominated dielectric strength.

Referring again to the positively charged circle *a*, let it represent a sphere. The electric charges it has been determined by various experiments are on the outside surface of the sphere and not inside. This is apparent in the case of a cylinder open at the ends through which something may be passed; and also in the transferring of a charge on a globe by enclosing it with larger hemispheres. If an electroscope be covered by a wire cage and insulated below a charge may be brought near or in actual contact without any disturbance of the sensitive mechanism of the instrument. The surface being the thing affected, it becomes apparent that if one wishes to increase the capacity of a conductor, as a trolley-wire, the simple way is to increase its surface, as by making it twice as thick. Capacity may also be increased by filling the space through which the lines of force tend to pass with some dielectric other than air, as with petroleum, mica or glass. Large quantities of mica are so used in electrical machinery.

To measure the force of electricity obtained in primitive electric experiments a delicate instrument was necessary, and Coulomb invented the torsion balance, using a needle suspended at the centre of its gravity by a very fine wire or silk thread, etc. A minute electrical force of repulsion allowed to operate against one end of the needle so as to twist the thread was therefore measurable as a mechanical force. This principle is used in the torsion electrometer and various other instruments. Experimenting with a torsion balance, Coulomb demonstrated that the transfer of static electricity by in-

duction involved an expenditure of force, the force varying inversely as the square of the distance of the centre of the bodies affected. See ELECTRIC MACHINE — *Static Electric Induction Machine* and ELECTROTHERAPEUTICS, where various static machines are described and illustrated.

**ELECTROTAXIS.** See ELECTROCULTURE OF PLANTS.

**ELECTROTHERAPEUTICS,** or the treatment of disease by electricity, began to be a science with the work of Duchenne of Boulogne. Working chiefly with a faradic current he determined the motor points of the various muscles or the places upon the skin where the application of the current produces contraction of the individual muscles. And for a long time the testing and treatment of paralysed muscles was the principal function of the electrotherapist. The burning and sometimes fatal effect of lightning had always been known and our countryman Benjamin Franklin had charged a Leyden jar with electricity collected from the clouds during a thunder storm. Franklin, after whom static electricity is denominated Franklinic electricity, was among the first to experiment with the shocks and muscular contractions produced by static electricity.

One of the types of electricity employed in electrotherapeutics and electrodiagnosis is Galvanic or Voltaic electricity or the constant direct current. This is obtained from a voltaic battery or from a storage battery, or from the direct current electric light circuit (suitably controlled) or from the alternating current electric light circuit employed to actuate a motor generator of direct current.

For various purposes the strength of the current may be regulated in the case of a battery by selecting the proper number of cells, and in the case of the other sources of voltaic currents by rheostats or variable resistances placed in the path of the current or by volt controllers. The latter regulate the voltage at the terminals applied to the body by offering the current a side path of variable resistance through which a greater or less part of the current may pass. A milliampere meter to show the strength of current traversing the patient is essential. For many purposes the current should have such or such a strength; and for all kinds of electrodiagnosis we must be able to determine the strength of current required to produce certain physiological effects. Conducting cords or flexible insulated wires pass from the control table to electrodes in contact with the patient. The simplest example is a flat metal disk covered with fabric wet with a dilute solution of bicarbonate of sodium, preferable to salt which discolors the metal, and provided with an insulated handle. Some other electrodes are a needle in an insulated handle; a carbon plate covered with a wet pad in a non-conducting tray partly filled with bicarbonate of sodium solution; a metal plate in an insulated bathtub of water; a metal sheet thickly covered with damp clay; or a bare metal cylinder which may be grasped in the hand. The galvanic or voltaic current is a bipolar application, passing through the patient's body between two separate electrodes, one the anode from the positive and the other the cathode from the negative pole of the battery or other generator. A switch

is essential for turning the current on or off. A pole changer alters the polarity of the electrodes by changing the connections at the control table by simply turning a switch. A pole detector is a necessary apparatus and a convenient one contains a colorless liquid which changes to red at the negative terminal.

**Effects of the Galvanic Current.**—One important effect is muscular contraction. This does not occur during the uniform passage of the current, but at the moment of any great variation in the strength of the current, as when a strong current is suddenly turned on or off. If the current were gradually increased from zero to the same maximum, no muscular contraction would result. In electrodiagnosis one electrode is called the indifferent one and is placed at some place remote from the region

of the motor neuron itself. It occurs in poliomyelitis, labioglossopharyngeal paralysis, and paralysis accompanied by lesions of the motor roots or of the motor nerves. In its complete form there is (1) abolition of galvanic and faradic excitability of the nerve; (2) abolition of the faradic excitability of the muscle; (3) hyper or hypoexcitability of the muscle with or without inversion of the normal formula,  $Ca C C > C C$ ; (normally cathode closure contracture exceeds the anode, positive, closure contracture) but the muscular contraction is slow instead of the normal sharp jerk. The presence of the reaction of degeneration shows what nerves are affected and to what extent; and the return to a normal reaction indicates progress toward recovery of voluntary muscular power.

The auditory reactions to the application of electricity form a very delicate and important means of the diagnosis of lesions in the labyrinth of the ear. For example, one of the normal reactions is obtained when an electrode is placed in front of the tragus of each ear and a galvanic current is applied. The patient feels dizzy and the outside world seems to be moving toward the cathode and the head is inclined toward the anode. He may see sparks before the eyes and hear a noise in the ears, and if the current is quite strong there is nystagmus or oscillation of the eyeballs.

A sensation of taste accompanies any application inside the mouth and often applications to other parts of the face.

The heating effect of electricity is well known but suitable galvanic currents are so weak that the sensation of warmth or even the reddening of the skin in contact with the electrode is usually due to electrolysis and not to the frictional resistance to the passage of the current. Very heavy galvanic currents of over 100 milliamperes, applied inside the uterus in the Apostoli treatment for fibroid tumors, did produce a great deal of heat but treatment by radiotherapy (X-ray and radium) is now more usual.

**Galvano-cautery.**—Instruments which are connected with both poles of the battery so that no current passes through the patient, are arranged so that a certain part becomes red hot owing to the passage of a heavy current through a thin metal strip in the same way that the filament in an electric light bulb is heated by the passage of the current. Only the portion which is to be applied to the diseased surface becomes appreciably hot because the conducting wires are larger and capable of transmitting the current with less resistance. Familiar examples of galvano-cauterization are in the treatment of growths in the nose and larynx.

Electrolysis is an effect of the passage of a constant current through an electrolyte such as the human body. A chemical compound such as water is separated into its elements such as hydrogen and oxygen, and in the case of the human body an accumulation of sodium hydrate and a liberation of oxygen take place at

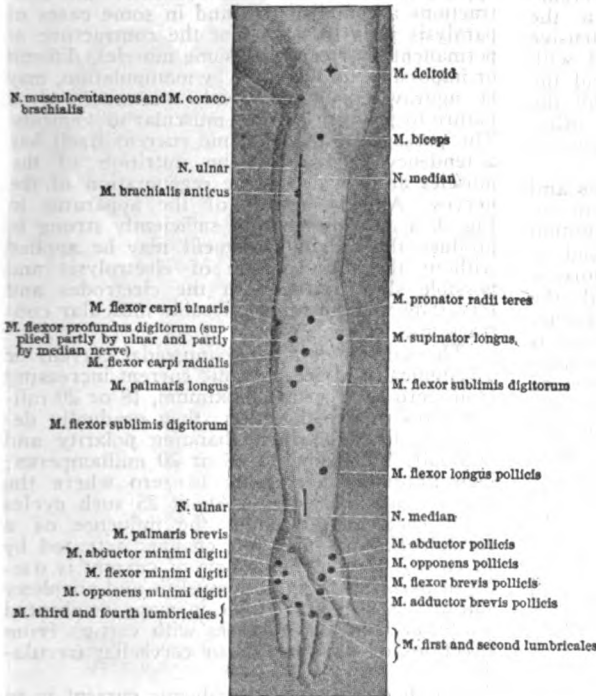

Motor points, palmar surface, of the upper extremity.

FIG. 1.

(From 'Medical Electricity,' courtesy W. B. Saunders & Co.)

under examination. The other, active, electrode is applied to the skin either over the nerve at the place where the nerve is nearest the surface, or over the muscle at the place where the motor nerve enters the muscle. These two places are called the motor points for the nerve and muscle respectively, because at these the application of electricity is most effective in producing muscular contraction. Figure 1 from a standard text-book is a chart of the motor points in the arm and is used as a guide in electrodiagnosis or treatment. The threshold of excitability is the weakest strength of current which when suddenly turned on or off will cause muscular contraction. The *reaction of degeneration* takes place in many cases of paralysis and indicates a degeneration in the substance

the negative electrode and an accumulation of hydrochloric acid and a liberation of oxygen at the point of contact with the positive electrode. If the negative electrode is a fine needle thrust into a hair follicle, a current of about four milliamperes causes a liquefaction of the tissues and loosening of the hair, the root of which may be permanently killed. A needle connected with the positive pole of the battery would stick fast and could not be withdrawn until a negative current had been turned on for a short time to loosen it by liquefying the tissue around it. The *anodal* needle has a coagulating effect. Electrolysis is employed also for the destruction of warts, birth-marks and keloids, in the treatment of strictures of the urethra and œsophagus and such lesions as anthrax.

For most of these cases the "indifferent" electrode is a sponge electrode held in the patient's hand; but for a more extensive destruction of tissue, needles connected with each pole of the generator are used and the needles are near enough together for all the intervening tissue to be destroyed. Rhy-nophyma, a bulbous swelling of the nose, is removed in this way.

**Iontophoresis, including Cataphoresis and Anaphoresis.**—A galvanic current tends to separate the electrode itself or the solution with which it is moistened into ions and to carry these into the tissues, iontophoresis. Metals and alkalis are carried toward the negative electrode or cathode and the introduction of these ions by an electric current is called cataphoresis. For example the positive electrode may be moistened with a solution of a cocaine salt and the cocaine will penetrate the tissues; they leave the anode and pass toward the cathode but their anesthetic effect is upon the tissues into which they first penetrate.

Some of those who have experimented most with iontophoresis assert that it is a more reliable way of administering many drugs, than giving them either by the stomach or hypodermically. Two rabbits were experimented upon by Leduc, as in Fig. 2. Rabbit A died with symptoms of strychnine and rabbit B of

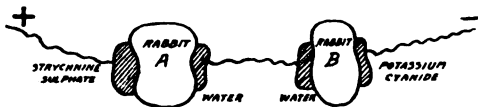

FIG. 2.

cyanide poisoning. Two other rabbits were subjected to the same experiment except that the direction of the current was reversed so that the strychnine ions did not tend to enter rabbit A, nor the cyanions the rabbit B, and neither was poisoned.

Another example of cataphoresis is electric ionization of the root canals of devitalized teeth. The positive active electrode may be a zinc needle moistened with a solution of a zinc salt. The method is employed to remove infection from the root canal and the area of the jaw around the apex of the root.

Very extensive destruction of cancerous tissue is accomplished by the introduction of metallic ions from large zinc needles amalga-

mated with mercury and connected with the positive pole while the patient lies upon the large indifferent negative electrode.

Anaphoresis or the introduction of acid radicals which the current carries toward the anode, is illustrated by the introduction of salicylic ions from a cathode wet with a solution of sodium salicylate, in rheumatism and neuralgia.

The old theory about the use of electricity in paralysis was that the involuntary contractions produced by the abrupt makes and breaks of the galvanic current and especially as we shall see later by the faradic current, tended to maintain the nutrition of the paralysed muscles until regeneration of the nerve took place. Certainly the patient and friends could see that something was happening during the application. It is doubtful whether the contractions accomplish this and in some cases of paralysis it is thought that the contracture or permanent shortening of some muscles, difficult or impossible to overcome by manipulation, may be aggravated by electrical treatment of a nature to produce marked muscular movements. The passage of the galvanic current itself has a tendency to maintain the nutrition of the muscles and to aid in the regeneration of the nerves. And by means of the apparatus in Fig. 3, a galvanic current sufficiently strong to produce the maximum benefit may be applied without the disadvantage of electrolysis and possible skin irritation at the electrodes and especially without any noticeable muscular contractions.

This current is a slow sinusoidal current or a rhythmically varied galvanic current increasing from zero to a certain maximum, 18 or 20 milliamperes in one direction; then gradually decreasing to zero; then changing polarity and gradually increasing to 18 or 20 milliamperes; then gradually decreasing to zero where the polarity again changes. About 25 such cycles occur each minute under the influence of a variable rheostat and pole changer actuated by an electric motor. This type of current is useful in paralysis from poliomyelitis and apoplexy and also as a general tonic in many debilitated conditions and also in cases with vertigo from affections of the cerebral or cerebellar circulation.

Another effect of the galvanic current is to stimulate the secretion of glands. Another is to promote the return of sensation in paralysis of a sensory nerve. By its sclerolytic effect it aids in the treatment of pleuritic adhesions and of ankylosis or joints stiffened by some previous inflammatory condition. Galvanic electricity has a sedative or calming effect valuable in many general disorders and this effect is often best produced by hydroelectric baths. Its analgesic effect makes it valuable in the treatment of neuritis and neuralgia.

**Faradic electricity** is made up of alternating currents induced in a coil with many turns of insulated wire surrounding a coil with few turns of wire through which passes a current rapidly made and broken by a vibrating interrupter. The faradic current is of very small electrical quantity as measured by its heating effect. A couple of dry cells may supply the current for a portable faradic coil but for an office equipment the electric light circuit suitably controlled is best because it does not re-

quire renewal and affords also power for the galvanic, galvanofaradic and sinusoidal currents. It produces marked muscular contraction of a tetanic type continuous during the entire time the current is applied, not merely at the beginning and end as with a galvanic current.

Two electrodes are necessary for applying the faradic current; one of which may be at an indifferent place. And in contrast with the galvanic current there is usually no difference in the effect of the two electrodes, practically

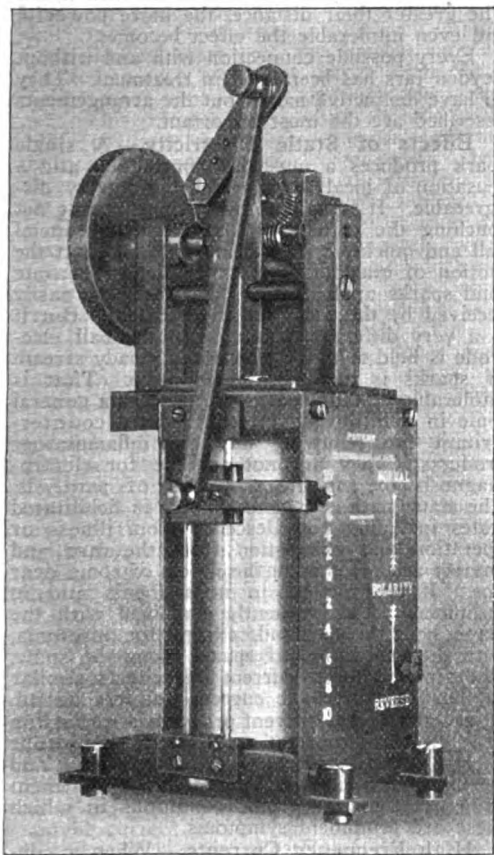

FIG. 3.

Sinusoidal Apparatus, gradually and rhythmically changing the polarity and strength of a galvanic current.

no polarity. Testing the faradic excitability of a muscle or nerve is an important part of electrodiagnosis, but, as explained above, the treatment of paralysis through involuntary muscular movements induced by faradic stimulation is not always best. Faradic currents from a secondary coil with a comparatively small number of turns and a slowly vibrating interrupter, are more effective in producing muscular contractions, and a great many turns of wire in the coil and very rapid interruptions are best for producing a sedative effect upon neuralgic nerves.

There are several other effects of faradic electricity. As a general stimulant it is used in debility from any cause. As an excito-motor;

the Bergonié method is used for the treatment of obesity by producing marked muscular contractions without any effort on the part of the patient. Straps or weights prevent excessive movement of the patient's limbs. As a sensory stimulant it is used in sensory paralysis. It stimulates the secretion of glands. It is re-ulsive or counterirritant in the later stages of inflammatory processes. Lumbago may be treated by applying faradic electricity with a dry wire brush electrode. It is excito-nutritive and tonic as a hydroelectric bath, in such diseases as gout, diabetes, obesity, neurasthenia, convalescence from a long illness, and muscular atrophies. And the same baths are useful in combating various toxæmias. It may be used as a sedative.

The same conducting cords and electrodes may transmit to the patient a combination of faradic and galvanic current, in series; the De Watteville or *galvano-faradic* current.

*Galvano-faradic* or De Watteville currents are applied by connecting a faradic and a galvanic apparatus in series with a conducting cord leading from one pole of each to the different parts of the patient. One example of its use is in the treatment of spasmodic constipation. Large electrodes are over the abdomen and back; the faradic coil has many turns and the interruptions are rapid, producing very slight muscular contractions; and the galvanic current is quite a strong one, perhaps 30 milliamperes.

Sinusoidal currents are so called because the graphic curve in which forward motion represents time and up or down motion represents strength and direction of the current makes a sine wave. In effect it is an alternating current varying gradually as described in one of the paragraphs on galvanic electricity, but these gradual alternations may be of any desired number up to 1,800 per minute. The alternating electric light current is a sinusoidal current of 1,800 cycles per minute and controlled by a suitable rheostat it can be used for treatment. The apparatus previously referred to and shown in Fig. 2 is used for changing the direct to a sinusoidal current of from 12 to 120 alternations per minute. It is useful as a local and general tonic application in a wide range of chronic general and local disease characterized by debility, congestion, motor atony and pain. It is applied from the same kind of electrodes as the galvanic current.

**Static Electricity.**—Lightning is an example of a discharge of static electricity and so is the spark which we produce by shuffling our feet on the woolen carpet as we cross the room in winter and then touch another person or a metallic object. A charge of static electricity upon a hard rubber comb rubbed over our hair or over wool or fur causes the comb to attract small light objects to it. By suitable means any object may be given either a positive or a negative static charge. Similar charges repel each other and unlike charges attract, and if the charged bodies are light and freely moveable, they will come together in the latter case and the two charges be more or less completely neutralized with an accompanying discharge which would be a loud spark between two large metal balls, or a silent and almost invisible brush discharge between two sharp metal points. Static electricity is of small quantity but of

such high voltage that it tends to escape from a charged body; in fact no body can be charged at all unless it is more or less insulated. Condensers are sheets of metal separated from contact with each other by sheets of glass or some other insulating material. One metal sheet is charged from one pole of a static machine and the other is charged from the other pole. Owing to the great attraction which charges of the two opposite polarities have for each other, when in such close proximity each will receive a much greater charge than it could contain separately. And if both are disconnected from the source of electricity the two opposite charges are actually self retaining, so that either can be touched by a conductor without losing its charge; but if a person touches both of the metal coatings at one time he receives a loud spark. Leyden jars with a dozen or more square inches of condensing surface are charged with a very small quantity of high tension electricity from a static machine and their discharge is used in electrotherapy under the name of the static induced current. A single electrode passes to the patient from the outer coating of a Leyden jar whose inner coating is connected with one pole of the static machine. The outer coating of the Leyden jar at the other pole is grounded (has a metallic connection with the earth). The patient need not be insulated. The distance between the discharging rods determines the voltage and consequently the degree of effect upon the patient. A wide separation of the discharging rods makes the static induced current suitable only for the application of sparks which are powerfully stimulant to both striated and smooth muscles and to all other tissues.

Condensers having a great many square inches of condensing surface interleaved like a book may be charged from the two poles of a galvanic battery. They receive a very large charge at a low voltage; and when they are discharged through the human body they produce marked muscular contraction. Since the capacity of the condenser and the voltage to which it is charged can be regulated, these low tension condenser discharges form a very exact means of electrodiagnosis. They may be used for treatment chiefly of paralysis, and for some of the same purposes as the static induced current.

The modern static machine, also called an influence machine, has its initial charge produced by friction upon a revolving glass plate. This is communicated to other glass or mica or fibre plates arranged in such a manner that as they revolve the mutual attractions of positive and negative static charges separated by insulating disks, result in the accumulation of very strong charges at the two poles of the machine.

Static insulation or the static bath is applied by connecting one pole of the machine with an insulated platform upon which the patient is seated. A static breeze is a silent, almost invisible discharge from a metal crown with sharp points connected with one pole of the machine, suspended within 6 or 12 inches of the patient. The effect is increased if at the same time the patient is insulated and receiving a static bath from the other pole of the machine. Static sparks are applied by bringing near any part of the patient, either clothed or not, a metal ball having an insulating handle

and connected by a flexible conductor with one pole of the machine. Here, again, the effect is intensified if the patient is insulated and receiving a static bath from the other pole.

The static induced spark is described in another paragraph.

The Morton wave current is a bipolar application from the two poles of the machine by two wet electrodes which make a very perfect contact with the patient to avoid any spark effect. The patient had better be upon an insulated platform. The discharging rods of the machine are only a fraction of an inch apart. The greater their distance, the more powerful and even intolerable the effect becomes.

Every possible connection with and without Leyden jars has been used in treatment. They all have distinctive names but the arrangements described are the most important.

**Effects of Static Electricity.**—A single spark produces a muscular contraction and a sensation of local shock which is not very disagreeable. It is applied by striking at but not touching the patient with the insulated metal ball and quickly withdrawing it; somewhat the motion of cracking a whip. A dozen separate loud sparks applied along the spine are easily received by the most sensitive patient. But it is a very different matter when the ball electrode is held near the skin and a steady stream of sparks is applied at one place. That is intolerable. Static sparks are used as a general tonic in debilitated states and as a counter-irritant for removing any old inflammatory products. They are not suitable for electrodiagnosis or for the treatment of paralysis. The static bath is a general tonic in debilitated states including convalescence from illness or operation and exhaustion from the care and anxiety attendant upon the illness of some dear one. It is excellent in neurasthenia and in insomnia. It is frequently combined with the static head breeze, and, except for insomnia, with the application of sparks along the spine. The static induced current has effects similar to those of the wave current but less useful.

Morton's wave current produces a succession of muscular contractions which should be slight. It is of value in relieving hyperemia and swelling and pain, and is used in the treatment of a great many chronic conditions in which these are prominent symptoms.

**High Frequency Currents.**—When a condenser is discharged by touching its two metal surfaces, the result is not an immediate change to an uncharged condition in each metal surface. Taking the surface that was positively charged we find that its charge drops not only to zero but to a certain distance on the negative side then back to zero and a certain lesser distance in a positive direction and so through thousands of oscillations in a small fraction of a second it comes to rest at zero. The oscillations are analogous to the vibrations of a piano wire after being pulled out of a straight line and released. The static induced current is the simplest example of a high frequency current but the discovery of the D'Arsonval current and of the resonator current has lately added a method of wonderful value.

The D'Arsonval current may be obtained from an induction coil, static machine or transformer, capable of producing sparks four to



eight or more inches long. The two poles are connected with the inner coatings of two Leyden jars whose outer coatings are connected with the extremities of a solenoid or cylindrical spiral of perhaps 20 turns of coarse wire about  $\frac{1}{2}$  inch apart. Conducting cords lead to the patient from each of the extremities of the solenoid or from any two turns of it. The apparatus but not its connection with the patient is similar to that shown in Fig. 4.

The inner coatings of the two Leyden jars are oppositely charged and are connected with the terminals of a spark gap of adjustable length or preferably, an adjustable number of short spark gaps in series. With each impulse from the induction coil, the Leyden jars are charged to such an extent that a discharge of their inner coats occurs through the spark gap. This releases the opposite charges in the outer coatings of the two Leyden jars and their high frequency discharge passes partly through the solenoid and partly through the parallel path formed by the patient's body.

One would suppose that with each discharge of the Leyden jars the current would almost all pass through the solenoid which is a relatively short length of thin wire whose resistance measured in ohms is trifling compared with that of the human body. There is however, a counter-electromotive force generated in a coil of wire at the making of the current which adds a great inductive resistance to the passage of the current and increases enormously the percentage of the current which will pass through any other path open to it. The current passing through the patient may be measured by a hot wire milliamperemeter and may be all the way from 50 to 1,000 or more milliamperes. It is also a current of much higher voltage than the galvanic and the fact that it does not cause muscular contraction or a shock of any kind is due to its very rapid oscillations, a million or more per second. The motor nerves respond actively to alternations of 20 to 2,000 or 3,000 per second but are inert in the presence of much higher than 5,000 oscillations per second. The oscillatory character of the current prevents the electrolysis which would render a constant current of 1,000 milliamperes intolerable. One principal effect of the passage of the D'Arsonval current through the tissues is the production of heat in the tissues themselves by ohmic resistance of the same nature as the production of heat by a current passing through a galvano-cautery wire or through the filament of an electric light bulb. Whether all the other effects are due to this generation of heat or whether some are due to direct stimulation of the tissue cells, is uncertain but the effects themselves are of the greatest value in therapeutics. D'Arsonval high frequency currents of moderate milliamperage may be applied by two wet electrodes or by bare metal electrodes; or by one glass electrode and a glass vacuum bulb or by autocondensation. Diathermy (or less properly called thermopenetration) is simply a D'Arsonval high frequency current of very great milliamperage tending consequently to produce a great deal of heat in the tissues. Two metal electrodes may be applied to a piece of raw meat and after the current has passed through for some time, the

meat will be found to be cooked all the way through. The electrodes themselves do not become too warm to be touched by the finger — are not warm at all until contact is made with the meat. This is the underlying principle of the *Deforest Cold Cautery* which is suited to all the purposes of a hot metal cautery.

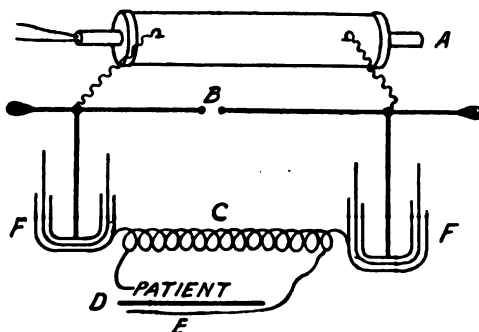

FIG. 4.—High frequency Autocondensation.

Diathermy may be applied by two wet electrodes, for instance at opposite sides of a joint, for producing a local effect. Or it may be used for producing a constitutional effect by means of *Autocondensation*. One conducting wire passes to a very large metal surface close to the patient's body but separated from it by a thick sheet of some complete and impenetrable nonconductor. The patient may hold one or more metal terminals from the other pole of the D'Arsonval apparatus or may be in close proximity to a second insulated surface charged from the other pole. During the application currents of high frequency, medium tension and high milliamperage (about 1,000) surge through the patient's body. The application produces very little sensation except a slight warmth and no shock or muscular contraction. The metal terminal must, however, be grasped before the current is turned on and not released during the flow of the current. Otherwise the patient will receive a succession of exceedingly hot sparks.

#### High Frequency Resonator Discharges.—

The Oudin resonator shown in Figure 5 is an apparatus for this purpose. The outer coat of one of the two Leyden jars is connected with the end of a wire spiral and the outer coat of the other with some part of the spiral between its two ends. With each discharge of the Leyden jars, a current passes through the turns of the spiral between the two connections and this induces a current passing toward the free end of the spiral and increasing in voltage until from its terminal a long spark or a violet colored effluve may be drawn; or a glass vacuum electrode may be used to apply this high tension high frequency current. The application is a unipolar one. When the vacuum electrode is held near the surface of the body a shower of sparks passes to the skin and this may be more or less disagreeable. This spark effect is largely avoided by keeping the electrode in contact with the surface. But even then tiny sparks may be seen passing from parts of the bulb not in close contact with the skin. These are not disagreeable. A sensation of

warmth is produced and the entire glass vacuum tube becomes heated in proportion to the strength of the high frequency current. The glass stem where the current enters from the insulated handle and the surface in contact with the patient are hotter than other parts of the electrode. The bulb is filled with a violet and ultraviolet light. The latter is invisible but its presence is easily demonstrated by fluorescence induced in Willemite. It doubtless is partly concerned in the effect produced upon the tissues.

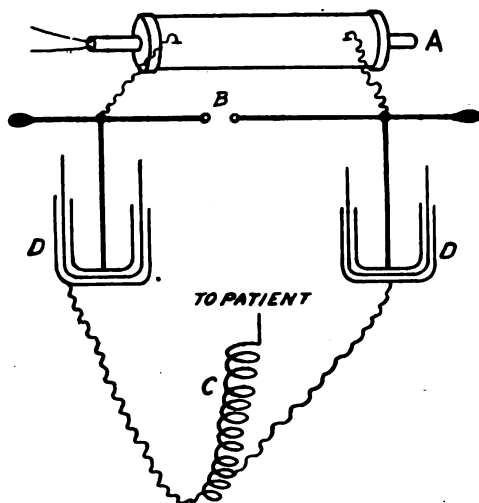

Fig. 5.—High frequency Resonator.

High frequency currents have little or no tendency to produce muscular contraction and are not used for electrodiagnosis. The spark effect is useful as a general tonic, to stimulate sensory nerves, to cause constriction of blood vessels locally and vasodilatation generally. Sparks applied from a metal point held close to the surface have a counterirritant or a destructive effect depending upon the strength of the current and the length of time sparks are applied to one spot without intermission. D'Arsonval currents, locally, raise the temperature and increase the circulation, increase the activity of glands and are a sedative. Autocondensation increases the production of heat in the body, increases the urinary solids and acts as a sedative. And especially it reduces the blood pressure when that is unnaturally high. The vacuum electrode actuated by the Oudin resonator has the effect of heating the tissues and promoting cellular activity of every kind as well as increasing local circulation. It is a counterirritant when the current is strong or is so regulated as to produce considerable spark effect even with the electrode in contact with the surface. In this case its general effect is stimulating; but with the current adjusted to produce very little spark effect and a great deal of warmth from the vacuum electrode in contact with the skin it has a sedative effect, and tends to reduce unnatural high blood pressure.

Some of the conditions treated by high frequency applications are growths varying from warts to skin cancers; various skin diseases including acne; high blood pressure and

arteriosclerosis or hardening of the arteries; rheumatism; gout; neuritis and neuralgia; angina pectoris; hemorrhoids.

**Bibliography.**—Consult Gould and Pyle, 'Cyclopedia of Medicine' (Philadelphia 1912); Guilleminot, 'Electricity in Medicine' (New York 1906); Jones, 'Medical Electricity' (6th ed., Philadelphia 1913); Martin, 'Practical Electro-therapeutics' (Saint Louis 1912); Neiswanger, 'Electro-therapeutical Practice' (18th ed., Chicago 1912); Rockwell, 'Electricity in Medicine' (New York 1904); Tousey, S., 'Medical Electricity and Roentgen Rays' (Philadelphia 1910, 1915).

SINCLAIR TOUSEY, M.D.  
New York City.

**ELECTRONIC STATE**, a term invented by Faraday (q.v.) to designate the total magnetic flux due to a conductor conveying a current, which linked with any secondary circuit in the field or even with itself. By careful experiment he proved that electromotive forces set up in conductors by the induction of other currents in the field were caused by the cutting lines of the secondary circuit. See ELECTRICITY.

**ELECTROTHERMAL PROCESS**, the term applied to electrometallurgic operations in which electricity is employed solely as a heating agent, to distinguish them from electrolytic processes. In special electrothermal processes, as the manufacture of calcium carbide, the mixture of substances is raised by the electric current to the temperature at which the chemical reaction desired will take place. In other electrothermal processes the heat is applied to produce molecular or physical changes, as in the manufacture of graphite from gas-carbon or coke. The continuous current only can be used in electrolytic work, whereas an alternating current is also available in electrothermal work. See ELECTROMETALLURGY.

**ELECTROTROPISM**. The sensitiveness of plants to cultivation by electricity. See ELECTROCULTURE OF PLANTS.

**ELECTROTINT**, a method of tracing drawings, etc., for printing, by the action of electricity on a copper plate. The design is drawn in some varnish not affected by acid and placed in an electro-bath, the lines being thus brought out in relief.

**ELECTROTYPE**, a metallic copy, made by electro-deposition, a form of type, a "cut," engraving, etc., and manufactured into proper shape for printing. Wax is heated in a kettle, poured out on a molding-case and placed in a press to receive a reverse impression of the form, engraving, etc. The face of the wax mold is covered with plumbago to give it a conducting surface to which the metal will adhere. The negative pole of a battery is attached to the mold and the positive to a piece of copper (or occasionally nickel or iron) and both are placed in a bath of sulphate of copper in solution. The copper is deposited on the face of the mold in a thin film, which increases in thickness as the process continues. The shell having attained the thickness of a stout sheet of paper the mold is removed from the bath, the shell detached and strengthened by a backing of electrotype metal, this being a composition of lead, tin and perhaps a little antimony. The electrotype shell being washed is laid face down

on a metal surface and a sheet of tin foil melted on to the back, after which the backing metal is poured on in a molten condition. After cooling, the electrotype plate goes to a planer, shaver, trimmer, etc., until reduced to the proper form for printing. Later it is remounted on a base of wood or metal to bring it to the same height as type, that it may be printed in a form with type; or sometimes the plate is curved in a bending machine for rotary printing. For details of the electric bath employed, see **ELECTROCHEMISTRY**. When the copper electrotype is faced with nickel it is sometimes called nickel-type, or if with iron, steeltype. The electrotype plate has almost wholly superseded the stereotype for book and miscellaneous printing, though the stereotype is retained for rotary newspaper printing.

**ELECTRUM**, a substance mentioned by Greek and Latin writers, with regard to the nature of which there has been much discussion. The term was used with different meanings; it originally meant gold, and was then applied specially to native gold, containing quantities of silver, copper and other metals. The term employed for this native alloy was transferred to the artificial alloy of gold and silver, afterward made, and was also applied to amber on account of its color and inferior lustre. The natural alloy occurring in Placer County, Cal., and Humboldt and Nye counties, Nev., contains about 40 per cent of silver. It is the principal mineral in the ore at National, Humboldt County, Nev.

**ELEGY**, properly, a poem of mourning. The Greeks and Romans, however, employed the term to denote a poem written in elegiac verse, whatever its character. This elegiac verse was the distich, consisting of the hexameter alternating with pentameter. Catullus, Propertius, Tibullus and Ovid were masters of the elegiac style. In modern times the term elegy is usually applied to any serious piece in which a tone of melancholy pervades the sentiments, as in Gray's 'Elegy Written in a Country Churchyard.'

In music, the term is used to denote a sad or suppressed theme.

**ELEGY WRITTEN IN A COUNTRY CHURCHYARD**, a poem by Thomas Gray, often said to be the most popular piece of verse in the language. It is thought to have been begun at Stoke-Poges in 1742, resumed at Cambridge in 1749 and finished at Stoke in June of the next year. Gray at once sent a copy to his friend Horace Walpole, who showed it about. Early in February 1751 the poet received a letter from the editor of a magazine announcing the intention to print it. Gray thereupon through Walpole arranged for its publication by Dodsley on 16 Feb. 1751. Its success was instantaneous. Eleven editions were published in speedy succession, translations were made into Latin and into numerous modern languages, and parodies and imitations flooded the world. Subsequent reprintings, especially in anthologies, have secured for it an enormous circulation, and, although it has not escaped the disparagement sure to be vented upon what is hackneyed, it has retained an unparalleled hold upon public affection. It would be a rash critic who should attempt to deny classic rank to Gray and his best-known poem.

Three copies exist in Gray's handwriting, and a study of the readings and the suppressed stanzas, as well as of the poet's borrowings from himself and others, is a valuable exercise for the student of poetic style. Owing to the almost flawless felicity of the diction and to the admirable fitness of the pentameter quatrain to the purposes for which it was employed, there are but few of the 32 stanzas that do not yield some memorable phrase or line, many of which have become stock quotations, such as "The short and simple annals of the poor," and "Far from the madding crowd's ignoble strife."

As has been intimated, the 'Elegy,' through its own popularity due to its own excellence, has contributed to its own decline in favor among those exigent persons who feel that it is an offense against taste to praise what the masses like. A moment's thought, however, should convince even the most fastidious that the masses are right. The 'Elegy' is not profound, or subtle, or exceptionally imaginative, or full of ravishing surprises in phrase and cadence. Had it been it would have failed of its purpose to express with consummate dignity and felicity the thoughts and feelings common to humanity in the presence of death and its monuments. The 'Elegy' is popular because the honest critic will confess that he could not improve it if he would and because the average reader has never thought it needed improvement. It is about as perfect a poem of pensive melancholy as the world can show, and if all its predecessors and successors in the so-called churchyard poetry were lost and it alone preserved it would suffice to voice practically all the pertinent reflections and emotions connected with "the great leveller." Consult editions of Gray's poems by Gosse, Rolfe, Bradshaw, Phelps, etc.

WILLIAM P. TRENT.

**ELEMENT**, in chemistry, a primary substance that cannot be decomposed as may be done with compound substances. The different substances now admitted by chemists to be elements, together with those which are tentatively assumed to be so, until further evidence is accumulated, number (1918) 82. They are aluminum, antimony, argon, arsenic, barium, beryllium, bismuth, boron, bromine, cadmium, caesium, calcium, carbon, cerium, chlorine, chromium, cobalt, copper, dysprosium, erbium, europium, fluorine, gadolinium, gallium, germanium, gold, helium, holmium, hydrogen, indium, iodine, iridium, iron, krypton, lanthanum, lead, lithium, lutecium, magnesium, manganese, mercury, molybdenum, neodymium, neon, nickel, niobium, niton, nitrogen, osmium, oxygen, palladium, phosphorus, platinum, potassium, praseodymium, radium, rhodium, rubidium, ruthenium, samarium, scandium, selenium, silicon, silver, sodium, strontium, sulphur, tantalum, tellurium, terbium, thallium, thorium, thulium, tin, titanium, tungsten, uranium, vanadium, xenon, ytterbium, yttrium, zinc and zirconium. Whether any of these apparently elementary substances will be proved to be in reality compounds cannot be definitely foretold. The most that can be said is that up to the present time no force has been brought to bear on them sufficient to disrupt the atomic attraction which holds each in its individual form. Much speculation has been

indulged in concerning the fundamental structural differences that subsist between the atoms of the different elements, but no universally acceptable explanation has yet been offered to account for the fact that the thousands of compounds that have been studied are all composed of so small a number of essentially different constituents. The alchemists believed that every apparent "element" can be modified, or "transmuted," into every other one, and much labor was expended in the effort to transmute the baser metals into the "nobler" or more valuable ones. We now know that the problem of transmutation, if it is capable of solution at all, is at any rate far more serious than it was believed to be in the early history of chemistry. But there are numerous indications which suggest a relationship among the substances that are now accepted as elements, and it may yet prove to be possible to transform lead into gold, or tin into platinum. For some years past Sir William Crookes has been a consistent advocate of the theory which teaches that all matter is fundamentally the same, and he has shown that some of the "elements" can be resolved, by fractionation, into substances which exhibit spectra that differ from one another in a marked manner, any two consecutive members of the series showing close similarity in their spectra, while the extreme members of the series are totally dissimilar. (Consult his lecture before the Berlin Congress of Applied Chemistry, entitled 'Modern Views on Matter,' in *Science* for 26 June 1903). The theory of matter which is in favor at the present writing teaches that all atoms are composed of electrons (q.v.), which are all alike, but which are grouped together in various ways, and in various numbers, to form the atoms of the elements. If this view stands the test of further research the possibility of transmuting the elements into one another may not be altogether fanciful. The element radium (q.v.), which appears to possess the singular power of continuously emitting streams of free electrons, occurs in nature in certain varieties of the mineral uraninite. It is notable that the inert gas helium (q.v.) also occurs in this same mineral, though it appears to be present in the free state and never in actual chemical combination. It has been suggested that we are here face to face with a real case of transmutation of elements, the electrons that are emitted by the radium being slowly built up, within the uraninite, into new systems, which are nothing less than atoms of helium. See MOLECULAR THEORY; PERIODIC LAW; RADIATION; RADIUM.

**ELEMENTAL SPIRITS**, beings who, according to the popular belief of the Middle Ages, presided over the four elements, living in and ruling them. The elemental spirits of fire were called salamanders; those of water, undines; those of the air, sylphs; and those of the earth, gnomes. Paracelsus wrote a treatise upon them, and they play a part in Pope's 'The Rape of the Lock.'

**ELEMENTS**, Conscious. As is the case with any other process of analysis, the analysis of experience must disclose certain component factors from which more complicated experiences are built, and these are called conscious elements. It is by no means obvious that the psychical fragments which form the elements

in the psychology of the present day are not subject to further fragmentation, nor, for the matter of that, that there are any conscious elements whatever insusceptible to further fragmentation. Furthermore, the subdivision of an experience into its elements does not exhaust its analysis any more than the analysis of a mosaic is exhausted by an enumeration of the constituent bits of stone. Just as the arrangement of the constituent bits of stone is the really vital part of a mosaic, so the arrangement of the constituent bits of experience is the vital part of a mental state. The tentative character of conscious elements and the inadequacy of a psychology which confines itself to cataloguing them are all but entirely overlooked by perhaps the majority of experimental psychologists.

The general consensus of opinion among psychologists is that the structural elements—the items—out of which experience at any one moment is built are sensations and affections (qq.v.), and these alone. In determining what constitutes a single sensation, our knowledge of the physiological processes of the sense-organs often yields us indications which are contradicted by introspection, as in the case of the sensation of a color, which does not show upon introspection the division into separate light and color processes which is indicated by its physiology.

There is not so much agreement as to the nature of the simple psychological functions, or temporal sequences of psychological units. Stout assumes that the simple processes are cognition—i.e., sentience, simple apprehension, and belief and will—i.e., hedonic tone and desire or aversion. Brentano separates ideation or awareness from belief. Wundt regards all experience as a manifestation of the volitional process of impulse, which involves both sensory and affective factors. Consult Brentano, 'Psychologie' (Leipzig 1874); Stout, 'Analytic Psychology' (London 1896); Titchener, 'An Outline of Psychology' (New York 1907); Wundt, 'Grundriss der Psychologie' (Leipzig 1897); id., 'Physiologische Psychologie' (ib. 1902-03).

**ELEMI**, as commercially used at the present day, an oleo-resin obtained from the *Canarium lusonicum* of the Philippine Islands, also known as "Manila elemi." As found in the market it has the appearance of old honey, due to admixture with extraneous material, but when pure it is colorless, and has a pleasing fragrance. It is a mixture of resin with a volatile oil, the resin being compound, part (61 per cent) amorphous and part (25 per cent) crystalline; the latter known by the specific name, *amyrin*. The amorphous resin dissolves in cold alcohol; the crystalline only in hot alcohol. The hard elemi, most abundant in the West Indies, is obtained from species of *Bursera*, and is either yellowish or greenish, sometimes opaque and sometimes translucent, has a fatty lustre, is easily pulverized and very fusible. It is heavier than water, in which it is insoluble, although it is readily dissolved in either turpentine or alcohol. The Oriental elemi of ancient times was the African elemi, an extract of *Boswellia Frereana* or *Santiriopsis balsamifera*. The Mauritius variety is obtained from *Canarium paniculatum*. A large part of the elemi of commerce is produced from trees of different genera of the same family growing in tropical America. Brazilian elemi,

or *anime*, is the product of *Hymenaea Courbaril*. Mexican elemi, now rarely found in commerce, is the product of *Amyris plumieri*. It was formerly the base of a highly valued lacquer. Elemi is a regular constituent of spirit varnishes, and the Manila kind is used in plasters and ointments, and in the preparation of certain high grade printing inks. In Eastern countries it is also used as incense. Its active principle is a volatile oil obtained by distillation.

**ELEPHANT**, the largest of living land animals, the two species of which constitute the family *Elephantida*, of the sub-order *Proboscidea*. The better-known species (*Elephas* or *Evelephas maximus*) is native to the jungles of India; while the other species (*Elephas* or *Loxodon africanus*) is found in the forests of Africa.

The elephant is a huge, ungainly creature with an enormously heavy body, mounted on four short, columnar legs, the hinder ones bending like knees when he lies down, as he doubles them behind, and not under him; his tail is long and tapered, ending in a bunch of coarse hair; otherwise the wrinkled bluish-gray hide is quite hairless. His head is large, with big pendulous ears, small eyes, and a nose, prolonged into a proboscis or "trunk," which reaches to the ground when he stands erect. The average male elephant is 8 or 10 feet high, and weighs five tons or more. There is a pigmy race of the African elephant, however, found in the Kongo, which is not over seven feet in height. The incisors of his upper jaw are prolonged into tusks, which are, however, less useful to him, as weapons, than is his trunk. This organ enables the animal to pick up things from the ground, and to reach fruits or leaves many feet above his head, and it also conveys water to the mouth. Indeed, so great is the tactile sense of this singularly flexible proboscis that it has been likened to a hand. It is also its owner's chief weapon of offense and defense; for with it he can catch and crush a man with ease, or hurl aside the tiger. The nasal bones are rudimentary, to give room for the trunk. The powerful muscles of the trunk demand a large surface for their attachment, and accordingly the skull is very large, and yet is prevented from being excessively heavy by the presence of large air spaces between the inner and outer tables. The end of the trunk forms a prehensile organ with two flaps in the Indian elephant, one in the African. The tusks are not present in all elephants, and vary much in size. They lack all coating of enamel. The digestive system is typical of that of the herbivorous animals in general, except for the long, narrow form of the stomach, and for a peculiar muscle attached to the gullet, which renders regurgitation of water possible. The female has a single pectoral pair of mammae. Gestation lasts two years, and the young are suckled for two years more. The age which this huge creature attains is proportionate to its size; for captive specimens have been known to live a hundred years, and scientists believe that, in a wild state, it may live many years longer. The Indian elephant (*Elephas asiaticus*) differs from the African in having smaller ears and a longer head with concave forehead and smaller eyes; in this species, also, the hind feet are often five-hoofed, whereas in the African

they are never more than four-hoofed, though five digits are always present in both limbs. Though the two species present some differences as to dentition, the special peculiarity in the structure of the molars is common to both. These teeth are of great size, and are formed of vertical plates of dental bone, separately covered with enamel, and welded together by a bony "cement," so that each tooth looks like a number of teeth, cemented together. In both species, also, there are no canine teeth, and no incisors in the lower jaw; while the incisors of the upper jaw are developed into tusks, often weighing 150 to 200 pounds each. These tusks furnish the ivory (q.v.) which is so much esteemed for ornamental purposes. The Indian elephant for thousands of years has been the servant of man. From the earliest ages he has borne the Oriental warrior into battle, has hauled his stores and ammunition, and has even been taught to wield weapons. In peace he has piled logs and huge blocks of stone as unremittingly as a derrick, and has been the main feature in the processions of the native princes. In these last and always spectacular functions, the elephant's anklets, saddlecloth and trappings are often encrusted with gold and jewels; and the prince who sits in the canopied howdah on his back is not more gorgeously attired than his elephant. In this connection, also, the albinos of the elephant are prized far more highly than the ordinary sort; in Siam, indeed, the white elephant is royal and venerated. The catching of these elephants singly, or in herds, is by no means an easy task. In former years they were caught in pitfalls, but this practice has been abandoned, because the creatures were frequently injured. Modern methods are varied. Sometimes male elephants are decoyed by tame females trained for that purpose, until they are in close proximity to the hunters. These entangle their unconscious victim's legs in stout ropes, and when, eventually he finds himself trapped, he fights until exhausted. When, however, herds are hunted, they are driven by an ever narrowing circle of hunters toward the mouth of a strongly built stockade, or "keddah." When, after many days, surrounded and enclosed by their pursuers, they rush into the stockade, the great gate is shut upon them. They are then tamed by a variety of methods, which differ as the stockades do, according to locality. Once caught, the elephant is easily trained, a few months being, usually, sufficient to teach him all he needs to know. Methods of training vary in detail; but, after the first severe lessons, the trainer usually finds gentleness effective. The driver or mahout sits upon the elephant's neck and manages him by words and by the use of a small iron-pointed stick. Once tamed, elephants, except in cases where they become "bad," and have to be shot like mad dogs, often are so gentle that children may be trusted to play with them. Besides the differences between the two species, already noted, the African elephant is not as amenable to domestication and confinement as the Asiatic, and is the chief source of the world's supply of ivory. Indeed, the African elephant generally succumbs to disease and dies in confinement, while the only change noted in the Asiatic under the same circumstances is that the species generally does not breed in captivity. The African elephant is peculiar in that the great tusks, twice

as large as those of the Asiatic species, are present in both male and female, while in the Asiatic species they are found only in the male. Because of the demand for these, the African natives have made war upon the female as well as the male, and this leads naturally to a diminution of the species, as the number of tusks shipped has increased rather than decreased each year. The African elephant is now never used as a beast of burden, though in ancient Egypt he may have been so utilized. Elephants generally live in large herds, each herd led, and apparently governed, by a leader, usually the largest of the party. So marked a family resemblance exists between members of the same herd that, in India—where they are classed as "high caste" and "low caste"—different herds are easily distinguishable. The African elephants live in mountainous regions, the Asiatic ones in deep forests, whence they can issue to play in and drink of the waters in which they find so much enjoyment. Here, too, their trunks are serviceable. They are used to squirt water over the creatures' backs, or to spout it, playfully, at their neighbors. Elephants also caress each other by means of their trunks. The anecdotes illustrating the docility, affection, sagacity, irritability, capriciousness and revengeful spirit of the elephant are innumerable, and may be found in various well-known books on natural history. The natural enemies of the elephant, besides man, are the tiger and the rhinoceros, and the nasal horn of the latter often proves a more formidable weapon than the trunk and tusks of the elephant, and the sight of even a dead tiger is said to be enough to excite most elephants into a transport of fury. Consult Anderson, 'The Lion and the Elephant' (London 1873); Hornaday, 'Two Years in the Jungle' (New York 1885); Kipling, J. L., 'Beast and Man in India' (London 1891); Lydepper, 'The Game Animals of Africa' (ib. 1908); Neumann, 'Elephant Hunting in East Equatorial Africa' (ib. 1898); Sanderson, 'Wild Beasts of India' (ib. 1893); Selous, 'A Hunter's Wanderings in Africa' (ib. 1890).

**ELEPHANT MOUND.** See MOUND BUILDERS AND MOUNDS.

**ELEPHANT, Order of the,** an ancient Danish order of chivalry. It is said to have been instituted about the end of the 12th century by Canute VI to perpetuate the memory of a Danish crusader who had killed an elephant in the Holy Land. It was renewed by Christian I in 1462, and placed on its present footing in 1693 by Christian V. It is the highest of the Danish orders. The number of members, not counting those of the royal family, is restricted to 30. Foreign sovereigns are exempted from these restrictions. The fête of the order is held on 1 January, when the knights meet in the chapel of the order in the castle of Fredericksburg, taking rank by seniority upon seats over which are suspended their arms and devices. The insignia of the order are an enameled white elephant, with a negro mahout, bearing on a blue housing, bordered with gold and crossed with white, a sculptured tower. On state occasions the elephant is worn attached to a chain composed of elephants and castles of gold, with a letter D in gold to represent *Dania* (Denmark). The device of the order is *Magni animi pretium*.

**ELEPHANT-APPLE,** a large and handsome East-Indian tree (*Feronia elephantum*). It belongs to the orange family, and produces a large gray-colored fruit with a very hard rind.

**ELEPHANT BEETLE,** one of the great cetonian beetles of the genus *Megasoma* of Central and South America; especially *M. elephas*. It reaches a length of three to four inches, and is black, delicately pitted. A related species (*M. thersites*) occurs in California.

**ELEPHANT BUTTE DAM,** the largest of the government's irrigation projects, located in Sierra County, N. M., in the valley of the Rio Grande, 120 miles above the point where the river strikes the Mexican border. The lake formed by this dam is about 45 miles long and averages  $1\frac{3}{4}$  miles in width, submerging 40,000 acres and storing 2,642,292 acre-feet, or 862,200,000,000 gallons. The water is intended to irrigate 183,000 acres of very fertile land in the States of New Mexico and Texas and 25,000 acres in Mexico. The water stored is sufficient to irrigate all the crops which can be grown on this acreage for two years in case there should be no rainfall. The dam is of cyclopean concrete. It was begun in 1910 and completed in May 1916. The crest is 1,310 feet long and is 305 feet above bed-rock at its lowest point, 100 feet below the bed of the river. At its base the dam is 215 feet thick and it tapers to 18 feet at the crest, which carries a permanent roadway. The masonry content of the structure is 608,000 cubic yards, making it the third largest dam in the world (see DAMS). In addition to the irrigation feature it is estimated that from 25,000 to 30,000 electric horse power can be delivered at El Paso, besides the many smaller powers which will be developed when the high level canals are in operation.

**ELEPHANT FISH** (*Callorhynchus antarcticus*), a fish of the sub-class *Chimæroidea* or *Holocephali* (q.v.), found in southern seas, where it is the sole representative of its kind. The name alludes to the prominent projecting appendage of the snout. The young remain until an advanced stage of development within the remarkable seaweed-like horny egg-cases. The fish attains a considerable size and is sometimes eaten in New Zealand.

**ELEPHANT RIVER,** a river of Cape Colony, running into the Atlantic after a course of 140 miles.

**ELEPHANT SEAL,** the largest of the hair seals (*Macrorhinus leominus*), usually over 20 feet long, with a circumference of 12 feet around the thickest part of the chest. The female is much smaller than the male. In color this seal is grayish; its body is covered with short hair, growing in patches, which gives a spotted look to the animal. The head is proportionately large, with prominent eyes and thick eyebrows; the whiskers are long; and the canine teeth are so large as to form heavy tusks. The nose of the males is prolonged into a proboscis about a foot long, which, seemingly useless, hangs loosely over the face. When this is dilated it gives a new character to the creature's voice. This species has been almost exterminated, owing to the demand for its oil, though less than a century ago it was plentiful in the southern hemisphere. The skin is not valued for its fur and the flesh is not edible.



**ELEPHANT BEETLE**





The herds migrate southward in summer and northward in winter to avoid the extremes of temperature. The northern elephant seal *M. angustirostris*, is also nearly extinct, being confined to the island of Guadalupe, off Lower California. Consult Moseley, 'Notes by a Naturalist on the Challenger' (London 1879); Townsend, 'The Northern Elephant Seal' (*Zoologica*, Vol. I, No. 8, New York 1912).

**ELEPHANT-SHREW**, the typical species *Macroscelides*, of the family *Macroscelididae*, belonging to the order of insect-eating mammals. The body, in general appearance and size, resembles that of the common rat. The popular name alludes to its peculiar, elongated nose, which looks like an elephant's trunk. The hind legs, which are long and out of all proportion to the length of the fore legs, fit the animal for jumping, giving it the additional name of jumping-shrew. This insect-eater is confined to Africa. It moves by jumps, lives on the sandy plains, makes burrows in the sand and finds its prey among the grass and bushes.

**ELEPHANTA**, ɛl-ɛ-fān-tā, or **ELEPHANT ISLE**, called by the natives *Gharipur*, a small island in the Bay of Bombay, seven miles northeast of Bombay. It consists of two long hills and an intervening valley. It is celebrated for a cave temple 130 feet long, 123 broad and 18 high, supported by pillars cut out in the rock. Many of these were cut down by the Portuguese. There are 36 columns in six rows and in the centre is a gigantic trimurti or three-formed god—Brahma the creator in the middle, with Vishnu the preserver on one side and Śiva the destroyer on the other. There are other pieces of sculpture and also several other rock-caves. The date of these constructions is not known. A large stone elephant, which once stood near the landing place, gave name to the island. Pop. of the island about 500.

**ELEPHANTIASIS**, properly speaking, a peculiar and rare disease, sporadic or endemic in warm climates, and characterized by a chronic thickening of the skin and the underlying tissues, usually limited to a definite area, and subsequent to an impairment of the lymphatic circulation. The disease is of great antiquity and exhibits a great variety of forms, by reason of which it has received a large number of names, medical as well as popular. The term is now applied by the best dermatologists to one disease, and not to several as heretofore. Elephantiasis exists in an endemic form in Africa, India, the Indian Archipelago, the West Indies and South America. The extra-continental possessions of the United States bring this disease in their train. The endemic form of the disease commences rapidly. There is pain, heat, swelling and temperature. The lymphatics and blood-vessels soon become involved and the part affected seems to be attacked by erysipelas. In a few days the acute symptoms may subside. A recurrence of the attack leaves the arm, or leg, or scalp, or face, or genitals somewhat thicker, and repeated attacks may result in enormous deformities of the affected parts. In the most characteristic cases of the tropical countries the disease seems to be due to a blood parasite, the *Filaria sanguinis hominis*. This worm gets into the blood, at times through the agencies of mosquito bites, and blocks up the lymphatic channels. In other cases the disease is regarded

as a form of chronic erysipelas. In a few instances it is congenital. The treatment will depend largely on the type of the disease. Rest in bed, elevation of the limb, quinine for the *Filaria* and prompt medical attendance are the essentials. See **FILARIAL**; **PARASITISM**.

**ELEPHANTINE**, ɛl-ɛ-fān-tī-nē (Arabic, *Djesiret-az-Zaher*, "isle of flowers"), a small island in the Nile, opposite Assouan (Syene), remarkable for its ruins. The island is almost covered with ruins piled up on each other—Egyptian, Roman, Saracen and Arabic. At the beginning of the present century there were the remains of two temples in Elephantine, one a very interesting one built by Amunoph III. They were destroyed in 1822 by the governor of Assouan in order to obtain stone for building a palace. The greater part of the Nilometer, mentioned by Strabo, which stood at the upper end of the island, was restored in the 19th century. The quay built of blocks taken mostly from older monuments is from Roman times. Many fragments of pottery with inscriptions in Greek have been found, some of these being receipts for taxes.

**ELEPHANTINE PAPYRI**. Elephantine is a small island in the Upper Nile and the most southern of the old Egyptian fortresses. In the ruins of a small city which was on the southern end of the island Aramaic papyri in considerable quantities have been found. These reveal the fact that soon after the destruction of Jerusalem by Nebuchadnezzar a colony of the Jews found their way to the southern frontier of Egypt. In them is mentioned the house of Yahu which is probably Jehovah. They cover the period extending from 471 B.C. to 411 B.C. and bring much light to bear on Jewish customs and worship of the times of this important document. One contains a petition for the restoration of the house of Yahu which had been destroyed by Egyptian soldiers.

**ELEPHANTS, Fossil**. The present genus (or genera) of elephant had many now extinct representatives in the Pleistocene. Among these the best known is the hairy mammoth (q.v.) of Siberia and northern North America. The mammoth was smaller than the largest existing elephants, but a similar species, *Elephas columbi*, ranging over the entire United States, equalled the extant species in size. *E. imperator* from the Southwest stood even larger, being 13 feet high at the shoulder. Another Pleistocene elephant was *Mastodon Americanus*. This differed from the true elephants in its lower skull and breast-like molar teeth, of which several were in simultaneous use in each side of each jaw. The teeth were covered with enamel, but had no cement on the crowns. Straight traces of tusks remained in the lower jaw of the males. The Pliocene beds contain, besides several species of *Mastodon*, the genus *Stegodon*, with the molar teeth intermediate in character between those of *Elephas* and of *Mastodon*. In the Miocene the interesting genus *Gomphotherium* or *Tetraodon* is found. The skull resembles that of *Mastodon*, but is much lower and flatter. The mandibular symphysis is prolonged and bears the well-developed tusks. Upper and lower tusks alike are relatively short and banded with enamel. The molars have four cross-ridges in the later forms, three in the earlier ones. The height at the shoulder is less than six feet.

The body and limbs have their present structure. The next earlier form in the line of ascent was *Palæomastodon* from the lower Oligocene and upper Eocene of Egypt. The dentition was

$i \frac{1}{1}, c \frac{0}{0}, p \frac{3}{2}, m \frac{3}{3}$ . Both lower and upper tusks

were very short and banded with enamel. All the grinders were in use together. There was probably a snout more or less like that of a pig instead of a well-developed trunk. The lower jaw was longer than the upper. The occipital bones extended nearly to the top of the parietals. There was a third trochanter on the femur. The size varied between that of a small elephant and that of a tapir. There is a considerable gap between *Palæomastodon* and any known ancestral form, but it appears that *Mærritherium* of the middle Eocene of Egypt is not very far removed from its line of descent. *Mærritherium* has the dental formula

$i \frac{3}{2}, c \frac{1}{0}, p \frac{3}{3}, m \frac{3}{3}$ . Both first and third upper

incisors and the canines are very poorly developed; the second upper and lower incisors form short tusks. The molars are quadritubercular. The skull is quite unlike that of *Palæomastodon* and is long and narrow, with enormous cheek bones. The cranial capacity is relatively large. There appears to have been only a very slight trace of a trunk. The body was essentially like that of the elephants, though less specialized. An aberrant offshoot of the proboscidean stock is characterized by the possession of tusks in the lower jaw only. This offshoot, containing the genus *Dinotherium*, is quite like typical elephants in its body and limbs. The tusks point downward and are curved to the rear. The molars resemble those of the tapirs. The skull is low and flat and probably bore a trunk. (See MAMMOTH; MASTODON). Consult Andrews, C. W., 'Catalogue of Tertiary Vertebrata of the Fayûm, Egypt'; Scott, W. B., 'A History of Land Mammals in the Western Hemisphere' (New York 1913).

**ELEPHANT'S-EAR**, a name frequently given to plants of the genus *Begonia* (q.v.). It is applied more frequently to a plant bearing the name *Caladium esculentum*.

**ELEPHANT'S-FOOT**, or **HOTTENTOT'S-BREAD** (*Testudinaria elephantipes*), a plant of the yam family (*Dioscoreaceæ*), of which the rootstock forms a large fleshy mass, curiously truncate, or somewhat resembling an elephant's foot, and covered with a soft, corky, rough and cracked bark, recalling the shell of a tortoise, whence its generic name. From this springs annually a climbing stem, which bears the leaves and flowers, the latter being small and yellow. The starchy rootstock is used as food by the Hottentots. The plant is not infrequent in hothouses. The American plants known as elephant's-foot belong to the genus *Elephantopus* of the *Asteraceæ*. The genus comprises 16 species, natives of tropical or warm regions. Four are found in the United States, mostly to the south of Delaware. The best known is the Carolina elephant's-foot (*E. carolinianus*). This is an erect hairy herb, with thin oval leaves and bracted heads of blue or purple flowers in branching corymbs. It grows as far north as southern New Jersey and

west to Kansas, and is abundant in all the region to the south. Another species is known in the Southern States as tobacco-weed and devil's grandmother.

**ELEUSINE**, *ël-û-sî'nê*, a genus of grasses comprising six species, all natives of the Old World. The genus is represented in America by *E. indica*, the crab-grass or yard-grass, which is found in waste places all over North America except in the extreme north, naturalized from Asia. In its native places it is an important article of commerce. *E. corocana*, called in the west of India natchnee, nagla, ragie and mand, forms a principal article of diet among the hill people of the western Ghauts in India. It is cultivated also in Japan. *E. stricta* is also used for food.

**ELEUSINIAN MYSTERIES**, festivals held annually at Eleusis, a town of Attica, in honor of the goddess Demeter, or Ceres, the patroness of agriculture and procreative power of nature. According to the Homeric hymn to Demeter, the festival was established by the goddess to commemorate the hospitality of King Celeus of Eleusis, who received her as a wayfarer. The usual opinion is that they were begun by Eumolpus, the first heirophant, 1356 B.C. Great secrecy was observed in the celebration of the festivals, consisting of the greater and lesser mysteries. The greater mysteries were celebrated toward the end of September and the first of October, lasting nine days. The lesser mysteries took place at Agræ on the Ilissus during springtime. It was a capital offense to reveal any of the rites. They existed about 18 centuries and ceased during the invasion of Alaric, in 396. Consult Pater, Walter, 'Greek Studies; Demeter and Proserpina'; Cooper, Jacob, 'The Eleusinian Mysteries.' See MYSTERIES.

**ELEUSIS**, *ë-lû'sis*, a ruined village of Attica, but in ancient times a city of Greece, 12 miles from Athens. It was celebrated as the chief seat of worship of Ceres (Greek Demeter), whose temple here was the largest sacred edifice in Greece. The Greek government began here an elaborate system of excavations in the year 1882, with the result that many remarkable ruins have been discovered. Even the site of the ancient temples is a matter of debate, so completely have they vanished. There are not wanting, however, ancient remains, which include two propylæa, a sacred well, an ancient council hall and small temples. The great hall of initiation was a modest structure until after the Persian War when it was greatly enlarged, first by cutting into the rock at the back, and later by constructing another hall alongside the first. A great portico was added by Philon in the 4th century B.C., making a common front to both, and during the Roman occupation the interior was made into one great hall 178 feet by 170, with seven rows of columns. A little Albanian village, poor and mean looking, called Leusina, stands on the site of what was once powerful Eleusis. Consult Diehl, 'Excursions in Greece'; Philios, 'Eleusis, ses mystères, ses ruines, et son musée' (Athens 1896); Frazer, 'Pausanias' (2d ed., 1913). For a plan of the excavations, consult Baedeker's 'Handbook to Greece' (4th English ed., Leipzig 1909).

**ELEUTHERA**, ě-lŭ'thĕ-rā, British West Indies, one of the largest of the Bahama Islands, lying east of Nassau, near New Providence, the second most populous island of the group. It is, like most of the islands of the group, long and narrow, its length being about 70 miles, area 164 square miles. It exceeds the neighboring isles in fertility, and produces more oranges, onions and pineapples than any. Its chief town is Governor's Harbor with a fort and good harbor. Pop. 6,533.

**ELEUTHERIA**, ěl-ŭ-thĕ'ri-ā (Gr. *ελευθερια*, freedom), among the ancient Greeks a festival commemorative of deliverance from the armies of Xerxes. It was instituted after the battle of Platæa (479 B.C.) and celebrated annually at that place in the month Maimacterion, nearly corresponding to our September. At the dawn of day a procession marched through the town, at the head of which trumpeters blew the signal for battle. At midday a chariot was driven toward the altar crowned with myrtle and various garlands and leading behind it a black bull. In front of the altar the archon of Platæa immolated the bull to Jupiter and Mercury, eulogized the heroes who had fallen at Platæa and sprinkled the ground with wine. Every fifth year these solemnities were attended by contests, chaplets being the reward of the victors. See GREEK FESTIVALS.

**ELEVATED RAILWAYS.** See RAILWAYS, ELEVATED.

**ELEVATION**, in the liturgy of the Roman Catholic Church, the act of lifting up by the celebrating priest and presenting to the sight of the faithful the Host and the Chalice immediately after the consecration; this is the elevation by eminence. There is both in the Latin and in the Greek Church liturgies another elevation shortly before the communion. Prior to the promulgation and condemnation of the teaching of Berengarius in the 11th century the elevation after consecration appears to have had no place in the Latin liturgy; but from the beginning of the 12th century, when this custom was introduced, it spread rapidly and became universal and obligatory. It was the Church's way of confessing her faith in the truth of transubstantiation, attacked by Berengarius. In the Latin Church in the 12th century began and in the next century became universal the custom of ringing a small bell at the moment of the elevation, as is the present usage. But the ringing of the great bells in the church steeples and towers at the elevation which was pretty general in the 13th century is now not common.

**ELEVATION**, in astronomy and geography, means generally the height above the horizon of an object on the sphere, measured by the arc of a vertical circle through it and the zenith. Thus, the elevation of the equator is the arc of a meridian intercepted between the equator and the horizon of the place. The elevation of the pole is the complement of that of the equator and is always equal to the latitude of the place. The elevation of a star or any other point is similarly its height above the horizon, and is a maximum when the star is on the meridian. In architecture the term is applied to a geometrical delineation of the front or any face of a building in which all the parts are drawn according to the scale and not shown as they would

appear in perspective. It is one of the three designs necessary in outlining any work of architecture, the other two being the plan and the section.

**ELEVATORS.** The modern elevator is a direct evolution from the machine which Elisha G. Otis exhibited in 1853 at the World's Fair in the Crystal Palace, New York. Hoists of various kinds had been built before that time, but this was the first elevator wherein provision was made for stopping the fall of the car in the contingency of the breaking of the hoisting cables. During the next five years a number of machines were built similar to that exhibited, all being driven from line shafting. In 1859 the same inventor introduced an independent reversible steam-engine directly connected to the hoisting machinery, and from that date the era of the elevator as a separate institution of the age began. In 1871 the hydraulic elevator was introduced, soon to attain predominance in the elevator art and displacing the steam-engine. The year 1888 witnessed the first application of the electric motor to elevator machines, destined in turn to eclipse the hydraulic elevator. The first type of electric elevator machine, still in use to-day for low and moderately high buildings, consisted of an electric motor actuating a hoisting drum through the intermediary of worm gearing. Although this machine has been developed to operate satisfactorily at comparatively high speed, it could not satisfy the requirements imposed on the elevator art with the advent of the skyscraper. Thus in 1903 a new type of electric elevator machine was developed, known as the 1:1 gearless traction machine, which has since completely ousted the hydraulic machine from the field of high-rise, high-speed elevators. Another development in the electric elevator art is the so-called microdrive machine, first introduced in 1915. This machine is capable of accurately and automatically stopping an elevator platform level with the landing under any condition of loading. It is extensively used in all cases where heavy loads have to be wheeled on or off the elevator platform on trucks.

It is quite evident that the high state of development of the electric elevator to-day could not have been accomplished without improvements in the design of electric motors and controlling devices. At the time of the introduction of the electric elevator in 1888 the design of the direct-current motor was already well advanced, while alternating-current motors were yet in their infancy. In the next decade the energy of designers was mostly bent upon the further development of the application of direct current, resulting in 1897 in the introduction of the direct-current magnet controller. With this invention the direct-current electric elevator at once entered the field of high-speed elevator service and became a dangerous competitor of the hydraulic elevator.

The electric power systems at that time were mostly direct current, but began gradually to make place for the more economic two- or three-phase alternating-current systems. Along therewith polyphase induction motors had been introduced and began to be applied to elevators. The first attempts were not very promising. It would seem for a time that the polyphase alternating-current elevator never would be suitable

for high speed, owing to the fact that the motor operated only at a fixed single speed and to the inability to design suitable alternating-current magnets. To-day all of these difficulties have been overcome; polyphase induction motors are now easily built for two or more speeds as well as alternating-current magnets of sufficient power to operate controller and brake. In fact, the number of alternating-current installations to-day equals the number of direct-current installations and is doubtlessly destined to exceed the latter in the near future. Safety appliances were developed hand in hand with the development of the various types of machines. Grips to arrest and stop a falling cage were first designed to operate upon the breaking of the hoisting rope only. These soon proved to be inadequate, since they remained inactive in runaway accidents from various causes not due to the parting of the ropes. This defect was removed with the introduction of centrifugal governors, which actuate the safety grips when the car speed exceeds a predetermined maximum. In 1890 steel began to be used for guide rails, which previously to that date consisted exclusively of wood. This brought about a new type of safeties. Other demands came with the increase in elevator speeds, necessitating the design of safety grips capable of arresting a falling car without shock or injury to the passengers. Other safety appliances gradually developed but which have now become part of the standard equipment are: automatic stop at the terminals of the travel; slack cable devices to prevent further motion of the machine in case the car is obstructed in its descent; door locks to prevent the starting of the cage as long as the door is open, and to prevent the opening of door unless the car is at rest at the landing.

According to the foregoing there are, therefore, four general classes of elevators—belt, steam, hydraulic and electric.

**Belt-driven Elevators.**—This class of elevator, Fig. 1, is usually installed for slow-speed freight service in factories, is reliable and yet low in cost. The speed seldom exceeds 75 feet per minute. The machine is usually bolted to the ceiling of one of the floors. The middle one of the three flat-faced pulleys shown in the illustration is tight on the shaft and is adapted to actuate the hoisting drum through the intermediary of a worm-and-worm gear. The two outer pulleys are loose on the shaft and are belted, one by straight belt and the other by crossed belt to a line shaft pulley. To operate the elevator in the one or other direction the straight or crossed belt is shifted onto the tight middle pulley. The machines are provided with brake, slack cable device and automatic stop at terminal landings.

**Steam Elevators.**—Steam machines for elevator service may be dismissed with the reference that they are no longer in use. This has been due to the very large consumption of power with no compensation for the disadvantage in the matter of ease of control.

**Hydraulic Elevators.**—The hydraulic elevator installed in large numbers up to about the year 1900 is the so-called vertical hydraulic type (Fig. 2). In this type a cylinder of a diameter of 8 to 24 inches is placed in a vertical position in the elevator shaft or in any other

convenient location. Within this cylinder works a piston. The pull exerted thereon by the water pressure is transmitted through the piston rods to a number of sheaves, which in turn operate on the hoisting ropes. The sheaves introduce a gear ratio varying from 2:1 to 12:1 between the car and piston travel. The elevator is controlled by a lever placed in the car, which actuates the operating valve. For the ascent, the valve admits water to act on the piston, at the same time discharging the water underneath. The descent of the car occurs by

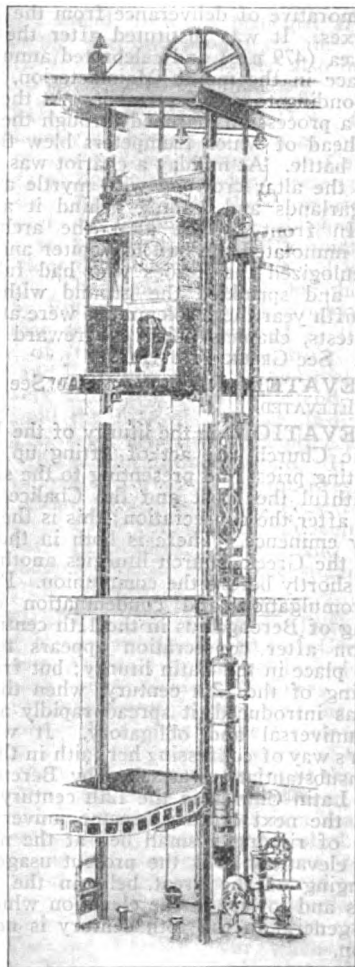
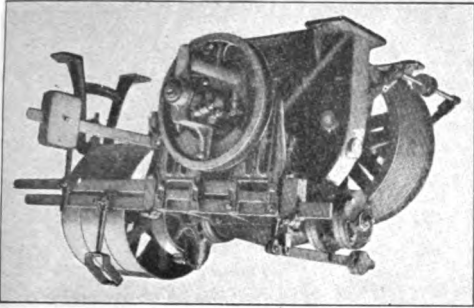

FIG. 2.—Standard Hydraulic Elevator Vertical Cylinder Geared Type Lever Control.

reason of its unbalanced weight, the water above the piston being allowed to flow through a circulating pipe to the space underneath. About the year 1900 the plunger type of hydraulic elevator (Fig. 3), (before that date applied only to low rises) began to be introduced for high speed passenger service. In this type a cylinder of a length equal to the car travel is set vertically in the ground. In this cylinder works a piston or plunger of the same length, carrying the car on its top. The weight of car and plunger is partially counter-

**ELEVATORS**



**1 Double Belt Ceiling-type Machine**

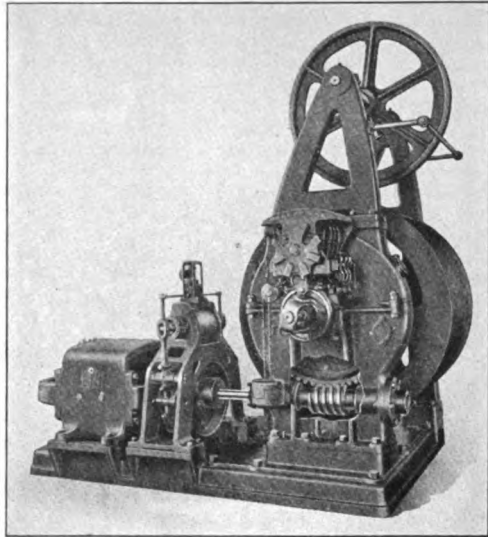

**6 Direct Current Single Screw Electric Elevator Machine**

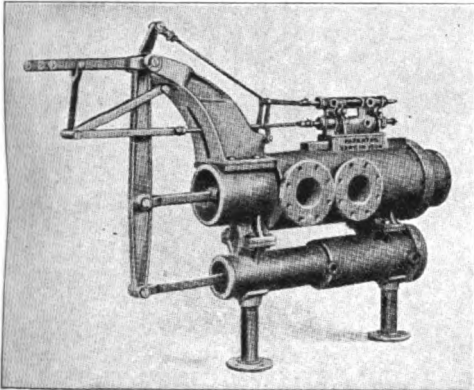

**4 Hydraulic Pilot Valve**

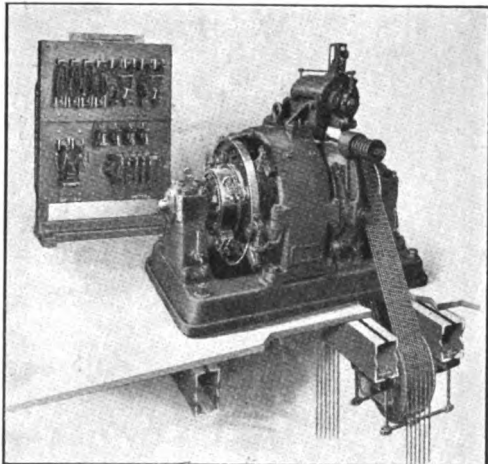

**7 Direct Current 1:1 Gearless Traction Elevator Machine Overhead Type**

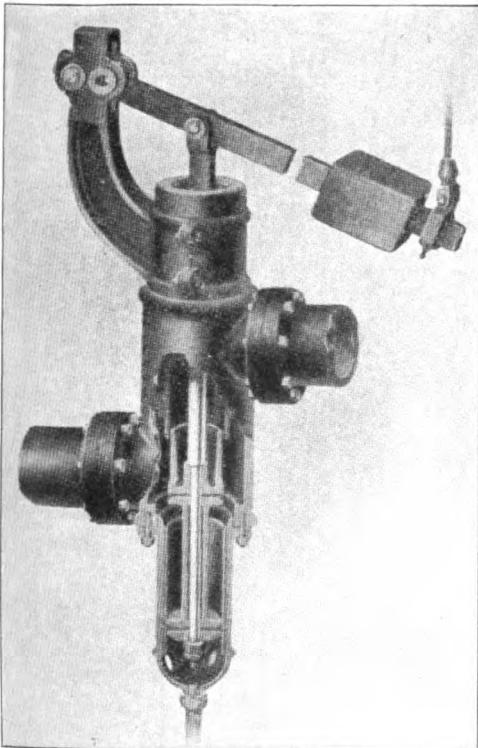

**5 Automatic Cut-off Valve for limited car travel, at top and bottom of hatchway**

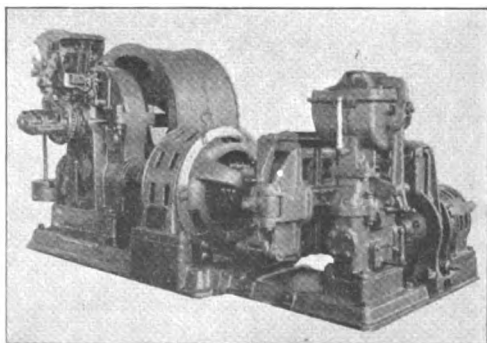

**8 Electric Micro Drive Drum Machine**

**ELEVATORS**

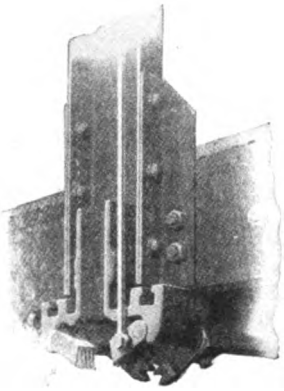

**9 Detail of Safety for Wood Guides**

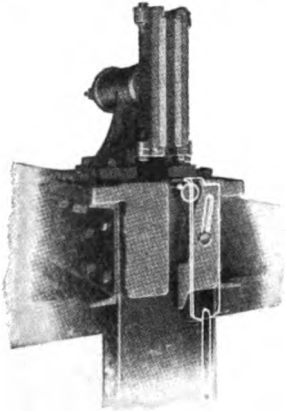

**11 Steel-roller Safety Appliance for Low Car Speed**



**14 Speed Governor**

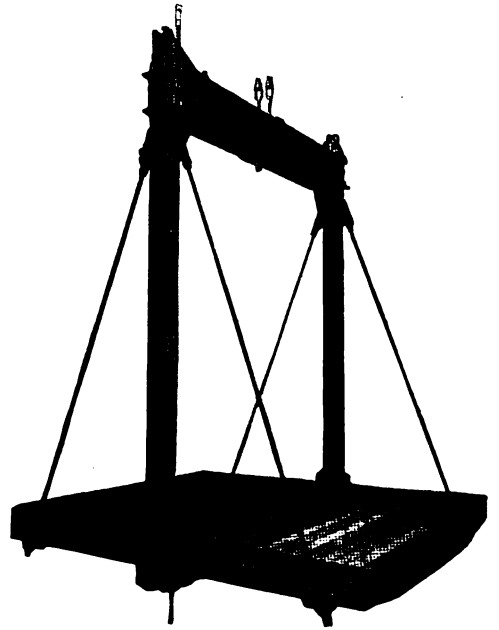

**10 Steel Freight Platform with Double Grip Safety**

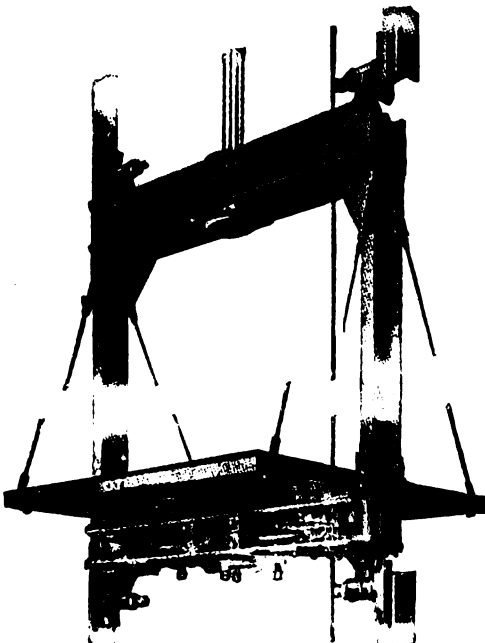

**15 Steel Car Frame Fitted with Wedge Clamp Safety**

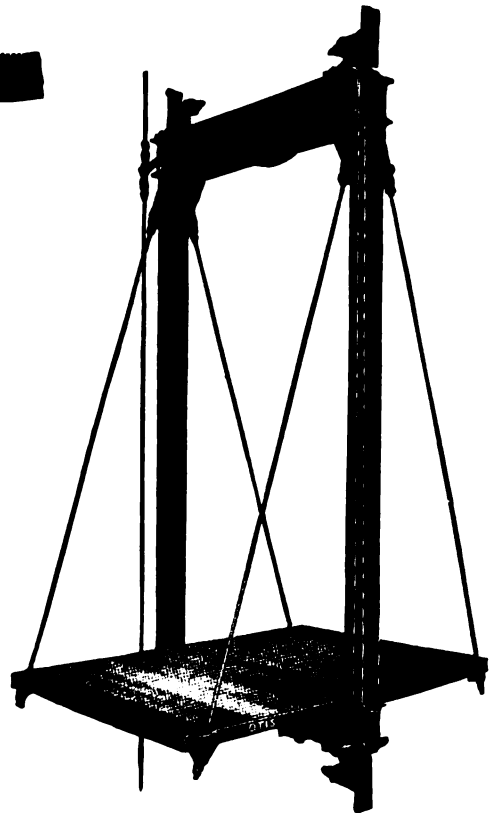

**12 Steel Platform with Roll Safety**

balanced by a weight attached to the car frame. Although this type of elevator had a larger power consumption and was more difficult to control than the vertical geared elevator, it succeeded in driving the latter from the field. This was due to the popular belief in the greater safety of the plunger elevator, since the load to all outward appearance was supported on a steel column and not suspended from ropes as in other types. As a matter of fact the plunger consisted of ordinary commercial tubing, finished to size and screwed together. That columns of this nature and of lengths up to about 300 feet could carry loads without buckling was due to the counterbalance, which for high rises exceeds the weight of live load and car. In reality therefore part of the plunger was in tension, and the load, instead of being supported on a steel column, was again suspended from ropes overhead. As the plunger rose out of the cylinder, its buoyancy decreased. To compensate, therefore, the weight of the counterweight ropes per foot is made equal to half of the weight of water displaced by one foot of plunger. In a high rise plunger elevator the masses to be set in motion and stopped are quite considerable. For a rise of 200 feet, for example, the plunger may weigh 4,000 pounds, the car 4,000 pounds, the ropes 2,000 pounds, counterweight, 4,000 pounds, live load, 2,500 pounds. For this reason, the control of the elevator at high speeds became difficult, notwithstanding the allowance of a liberal amount of underbalance and surplus pressure. The control of the elevator is effected by means of a lever actuating an operating valve (Fig. 4), which at the will of the operator permits water to flow into the cylinder for the ascent, or out of the cylinder for the descent. In addition, two automatic top valves (Fig. 5) are furnished, automatically to stop the elevator at the limits of its travel. Another type of hydraulic elevator machines, which may be dismissed with simple reference, is the horizontal hydraulic machine. It consists of a cylinder set horizontally. As in the vertical geared machine, the piston operates a number of multiplying sheaves. This type is distinguished as of the pushing or pulling type depending on whether the piston rod is in compression or tension. The desired water pressure is generally obtained by steam or electrically driven pumps. On low pressure systems of about 150 pounds per square inch, the pumps deliver the water into a pressure tank, which absorbs the pump pulsations

and serves as a storage of power. In high pressure systems, generally of about 800 pounds per square inch, the pumps deliver the water into a weighted accumulator. The water discharged by the machines is collected in a discharge tank from which again the pumps are supplied.

In addition to the types of hydraulic elevators mentioned above, there are the so-called aero-hydraulic and hydro-steam elevators. The elevator proper may be of any one of the hydraulic types already described, but they differ in respect to the manner in which the hydraulic pressure is obtained. In the aero-hydraulic machine a tank partly filled with water is connected to a supply of air pressure. The elevator ascends by simultaneously admitting air into the tank and water into the cylinder. For the descent, the air is discharged, while the machine returns the water to the tank. In the hydro-steam elevator, steam is employed in place of air. All hydraulic elevators absorb the same amount of power in each cycle of their operation, independently of the live load in the cage. The power consumption for this reason, notwithstanding an excellent mechanical efficiency, is quite large. In addition, the speed of the hydraulic elevators varies largely with the load in the car.

**Electric Elevators.**—These excel the hydraulic elevator by reason of a speed practically independent of the load and by a lower power consumption. They may generally be classed as having machines with winding drums or machines with traction sheaves. Further, distinction is made in respect to the type of gearing employed, into worm gear, worm and spur gear, herring-bone gear, gearless or 1:1 and 2:1 gearless machines.

Fig. 6 shows a typical worm gear machine with winding drum. The motor in the illustration is of the direct current type, but may be alternating of single or polyphase. The brake is placed between motor and gear housing and is of the shoe type with springs to hold the shoes in frictional contact with the brake pulley. The brake is released only upon the admittance of current to the brake magnet and is applied immediately upon the interruption of the current supply thereto. The hoisting cables lead from the cage to the face of the drum, where they are solidly anchored. At the opposite side of the drum a counterweight is attached, adapted to counterbalance the cage and live load. Frequently also a second counterweight is employed, suspended directly from the cage. The weight of the counterweight where one is used, or their aggregate weight where two are used, is made to exceed the weight of the cage by an amount of from 30 to 50 per cent of the maximum load. On account of this arrangement a relatively small motor can be employed since it will be subject only to from 70 to 50 per cent of the maximum load when lifting the same. When lowering the empty cage the load on the motor corresponds to from 30 to 50 per cent of the maximum load. The worm runs partially submerged in oil (preferably castor oil) and owing to the excellent lubrication the efficiency of worm gearing is higher than usually anticipated. The roping employed in a traction elevator installation is shown diagrammatically in

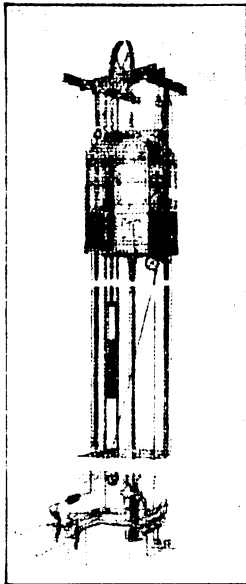

FIG. 3.—Plunger passenger elevator lever control.

Fig. 7 and will also be evident from Fig. 8. The machine is usually and preferably located overhead. The ropes pass from the car to the traction sheave, thence to an idler or secondary sheave and again over the traction sheave to the counterweight. The tension due to the weights of car and counterweight and the approximately two half wraps of contact between the ropes and traction sheave furnish the necessary adhesion to transmit motion from the traction sheave to the elevator without slip. This adhesion is instantly destroyed if either car or counterweight is obstructed in its descent, in which case motion of the elevator must cease even though the machine keeps on revolving. This property is a most valuable safety feature of the machine with traction sheave. By arranging the car to land on an oil buffer at the lower landing and by similarly obstructing the further descent of the counterweight when the car is at the upper landing, the car travel is absolutely fixed between two limits. Another advantage of the traction machine lies in the fact that the width of the traction sheave is independent of the height of the building. For a given capacity therefore, a standard machine can be provided, irrespective of the elevator travel. In the 1:1 traction machine (Fig. 7) the traction sheave is mounted directly on the motor shaft. As the illustration shows, the construction of the machine is simplicity itself. It consists of an armature with extended shaft, carrying a brake pulley and a traction sheave, all supported on two bearings. At full speed the motor runs at about only 60 revolutions per minute. Reductions in speed are obtained by means of field control and by manipulation of resistance in series and parallel with the armature. Contrary to popular belief motors for such low speeds can be made with as high efficiency as high speed motors, although, of course, the motor frame assumes considerable dimensions. Owing further to the absence of gears, the 1:1 traction machine has the highest efficiency of any elevator machine yet designed. Wherever it has replaced existing hydraulic elevators, the saving in power consumption has paid for the new installation within a few years. The microdrive machine shown in Fig. 8 derives its name from the fine adjustments in the stopping, which can be made with this machine in a manner not unlike the action of a micrometer.

To obtain accurate stops level with the landing it is necessary to slow down the cage to an extremely slow speed. In the microdrive machine this is obtained by having a main machine (which may be of any desired type) for ordinary hoisting purposes and an auxiliary machine for the stop. The main and auxiliary machines may be coupled together by a magnetically operated clutch carried on an extension of the main motor shaft. At the start, the coupling is released leaving the main machine free to hoist the load. Shortly before the stop the current supply to the main motor is interrupted while simultaneously the auxiliary motor is started up and the coupling applied. The effect of this operation is that the load is now transferred to the auxiliary machine, which drives the drum through its own and the main gear reduction. The cage therefore proceeds to the landing at extremely slow

speed controlled by an automatic leveling device. The function of this device is not only to stop the cage flush at the landing, but to maintain the alignment between cage and landing during loading and unloading. If for example a heavy loaded truck is rolled onto the car, the stretch of the hoisting ropes will cause the platform to sink below the landing as soon as the front wheels of the truck rest on the car floor. This will cause the auxiliary motor immediately to restore the alignment between car and landing before the rear wheels pass onto the platform. The controlling device most in use with electric elevators consists of a lever in the car operating a number of contacts. These in turn energize magnets assembled on a controller panel near the machine. The operator controls only the direction in which the car is to travel, the fast and the slow speed. Operations such as releasing the brake and stepping out the starting resistance occur automatically. In push button controlled elevators, each landing is provided with a button to call the elevator to that landing. The cage is provided with a series of buttons to dispatch the cage to any desired floor. A passenger desiring to use the elevator presses the button placed near the elevator shaft, and the car, if not in use, immediately travels to that floor and stops automatically. When the car has come to rest, the door can be opened. The passenger enters, closes the door and presses a button corresponding to the floor to which he wishes to travel and the car at once proceeds thereto. It will be seen that the push button elevator is entirely automatic in its operation, having the advantage of not requiring an attendant.

Although this type of control was developed many years ago, it has in the past found application only to slow speed residence and apartment-house elevators for the lack of a machine capable of making accurate stops level with the landing. With the advent of the microdrive machine, however, this type of control is receiving increased attention and it is safe to predict that it is destined to come into general use.

**Safety Appliances.**—While the factor of safety in the standard make of elevators is such that accidents rarely occur and practically never where proper attention is paid to the machinery, still all elevators (except plunger elevators) are equipped with safety grips. Of the very large variety of safeties, only those types which have found extensive application will here be described. With wood guides the type of safety generally used consists of an arrangement of planer teeth forced into the guides and producing resistance by planing or grooving the wood as the car descends. Figs. 9 and 10 show one form of this type of safety. With steel guide rails the types in use are the roll, wedge clamp and the flexible guide clamp safeties. The roll safety—shown on Figs. 11 and 12—employs a corrugated steel roller, adapted to be forced into the apex of an angle, formed by the guide rail and the inclined surface of the safety block. The angle usually is small so as to make the roller self-locking. This in turn causes an abrupt stop, so that the safety can be used only for low car speeds. In the wedge clamp safety, the rails are gripped between the



jaws of two clamps. As shown in Fig. 13 the safety is actuated by a drum having a hub provided with right and left hand screw threads which engage with two screws. Rotation of the drum in the proper direction moves the screws outwardly, forcing the wedges at the ends of the screws between the rollers of the clamp levers and causing the jaws to grip the rails. The drum is provided with a few wraps of rope, one end of which is fastened to the drum and the other to the governor rope.

Let us now imagine a falling car, equipped with a wedge clamp safety as here described, and analyze what will happen. Let us further assume that the normal speed of the car is 600 feet per minute. The governor (Fig. 14)—so as not to interfere with moderate speed variations from natural causes—will be set to trip at 800 feet per minute; that is to say, as soon as the speed of the car reaches 800 feet per minute, the governor jaws will grip the governor rope, causing the latter to come to rest quickly. As a consequence, the rope on the safety drum, having one end fastened to the governor rope, will unwind while the car keeps on falling. This will cause the safety drum to rotate, actuating the safety mechanism. Before, however, the jaws grip the rail, all of the clearances must have been taken up. During this

acceleration of the governor rope. It will therefore be seen that there is, at high speed, a considerable increment in the retarding force exerted by the clamps, resulting in undesirably heavy retardations. Another disadvantage is due to the fact that the safety must be made self-locking so that it will not release its grip on the rails, should the governor rope break. If, therefore, during the slide of the jaws on the rails, variations in the thickness of the rails occur, the jaws can yield only by virtue of their elasticity. That this will cause enormous variations in the retarding force in the one or the other clamp is plain and it is therefore no surprise that the platform frequently comes to a stop altogether out of level. These disadvantages have led to the development of the flexible guide clamp safety, first introduced in 1916 and now rapidly superseding the type described above. Each of its clamps has two jaws, one solid and the other provided with a wedge having its face slightly inclined toward the guide rail. Both jaws are pivoted and are adapted to compress a spring held between the clamp levers. The spring is normally free from compression. A roller is adapted to be brought in contact with the inclined face of the wedge on one side and the guide rail on the other. The inclination of the former is such that once

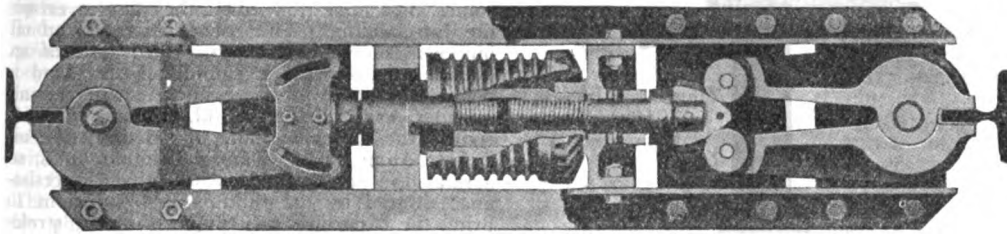

FIG. 13.—Wedge clamp safety.

time the car falls another 4 or 5 feet, equivalent to an increase in speed of approximately 1,000 feet per minute. At the time that the application of the safety begins, the car speed therefore has assumed very considerable overspeed, amounting in the present example to 1,800 feet per minute. This is decidedly a disadvantage. The jaws now grip the rail and, as a consequence, the rotation of the safety drum stops. The governor rope, previously at rest, is therefore suddenly accelerated to the car speed of 1,800 feet per minute and begins to slip through the governor jaws. The force then exerted on the periphery of the safety drum, which is a direct measure for the retarding force exerted by the clamp, is the sum of friction caused by the grip of the governor on the governor rope and of the force necessary to suddenly accelerate the same to car speed. Now it will be clear, that in the present example the safety should be designed to stop the car at any speed above 800 feet per minute. At a speed of 800 feet per minute, however, the effect of the sudden acceleration of the governor rope is small and most of the work is done by the friction caused by the grip of the governor on the governor rope. If, however, the car actually falls, action of the safety begins at a speed of 1,800 feet per minute with a very considerable effect of the sudden ac-

this contact is established, the roller continues to climb upwards until its motion is arrested. In doing so, it first forces the solid jaw to engage with the rail, after which it will cause the wedge—and therewith the jaw containing the wedge—to recede from the rail. The latter jaw thereby swings around its pivot and compresses the spring. The rail, therefore, will be gripped between the solid jaw on one side and the roller on the other side with a force corresponding to the spring compression. Since the travel of the roller is limited, the maximum amount of spring compression is also fixed and, with that, the retarding force which the clamps exercise can be arranged to be just sufficient for a smooth stop from any speed. It will be seen that the operation of the safety begins immediately from the moment that the roller makes contact with the wedge and rail. The time lag between the operation of the actuating mechanism and the gripping of the rails, existing with the wedge clamp safety, is here practically eliminated; indeed, the flexible guide clamp safety responds immediately to any demand for its operation.

Another advantage of this type of safety lies in the fact that it is practically not affected by slight changes in the thickness of the rail. This is, of course, due to the very flexible arrangement of the jaws. A slight increase in

the thickness of the rail will merely result in a somewhat higher spring compression without much increase in the retarding force of the clamps. The operation of a safety by means of a speed governor always has the disadvantage that no action occurs, except at a certain overspeed. If, for example, the hoist ropes break while the car is at rest, it is rather contrary to common sense to permit the car to fall and gather speed before the safety is applied. For this reason, the flexible guide clamp safety is arranged to be actuated in three different manners, viz., first, in the ordinary way by means of a speed governor; secondly, immediately upon the breaking of the ropes and thirdly, at the will of the operator.

**Air Cushions.**—An air cushion is the enclosure of the bottom part of the shaft to a height of from one-sixth to one-third of the car travel with just sufficient clearance for the



FIG. 16.—Oil buffer with spring return.

normal operation of the elevator. At high speed, therefore, the action is that of a piston within a cylinder. It is intended as an additional safeguard in case all other safety devices fail. The speed of a falling car within the air cushion is controlled in various manners, all tending to decrease the area through which air is permitted to escape, as the car nears the bottom of the shaft.

One of the advantages claimed for the air cushion is that it has no moving parts, so that no disarrangement can occur to prevent its operation. This claim, however, is not justified since, of course, there must be a number of doors within the air cushion zone for the ingress and egress of passengers. One of these left open or blown open by the air pressure may be sufficient to put the entire air cushion out of commission.

The main defect, however, is that a car at the top of the shaft is permitted to fall free for a distance of from five-sixths to two-thirds

of the height of the shaft before entering the cushion. As a consequence, the speed of the car at the entrance of the cushion is enormous and large retardations—dangerous to life and limb—have to be allowed to bring the car to rest within a comparatively small distance. By actual tests, velocities at the entrance of the air cushion as high as 10,000 feet per minute have been measured. Retardations observed have been as much as 10 times gravity, subjecting a person standing in the car to 11 times his weight. Air pressures have been measured as high as 16 pounds per square inch from which it will be evident that a heavy construction of the cushion and doors is required.

**Oil Buffers.**—With particular reference to high speed electric elevators, it is highly improbable, but yet conceivable, that all of the switches, which constitute the automatic stopping device at the terminal landings, fail. Under such conditions, the car will proceed at normal speed and since—in the absence of overspeed—the safety remains inactive, there is no agent to prevent the cage from striking the limits of its travel. Accidents of this kind are made impossible by the installation of oil buffers. One or more of them are placed in the pit and are struck by the cage as it overruns the bottom landing. Another buffer is usually attached to the counterweight and comes into operation when the cage overruns the top landing. The construction of an oil buffer is shown in Fig. 16. It consists of an outside casing with a cylinder within and a piston operating in the cylinder. Casing and cylinder are filled with oil. When the car strikes the buffer and the piston descends, oil is forced out of the cylinder through holes, so arranged in number and position that the resistance offered by the fluid is just sufficient to bring the car to an easy stop within the stroke of the buffer. The piston is returned to the upper position by a spring. Consult Baxter, William, 'Hydraulic Elevators'; Hymans, F., 'Elevators in the Oliver Building' (in *Electric Journal* 1911); Bethman, H., 'Der Aufzugbau'; Ernst, Adolf, 'Die Hebezeuge'; Lindquist, D., 'Modern Electric Elevators and Elevator Problems' (in *Transactions of the American Society of Mechanical Engineers*, Vol. XXXVII); id., 'The Micro-drive Machine' (1917).

DAVID LINDQUIST,  
*Engineering Department, Otis Elevator Company.*

**ELEVENTH CENTURY, The.** The 10th century is commonly said to have been an especially backward period in human achievement, due to the belief then prevalent that the world was coming to an end in the year 1000. This superstition is supposed to have placed an inhibition upon human effort which kept men from serious work. An interesting commentary on this generally accepted impression is to be found in the fact that the two men in the world's most prominent positions of the time, that is as emperor and Pope, who lived over from the 10th to the 11th century, are distinguished in history for their intellectual abilities while their lives are striking examples of the deep mental interests of the time. The Pope was Sylvester II (999–1003) who before he became Pope was known as the famous Gerbert, the most distinguished scholar of the

period. Gerbert wrote a series of works on philosophical, mathematical and physical subjects which have been preserved and which serve to illustrate the breadth of intellectual interest of the men of his time. He was no merely academic scholar but a man of very practical ability, for he is said to have introduced the use of Arabic figures into western Europe and to have invented the pendulum clock. A great improvement in the organ is also attributed to him and he is said to have notably influenced the development of music. As Pope, he is known for his determined insistence on the elevation only of men of unblemished character to the episcopal office and his consistent reformation of abuses. He maintained Church discipline firmly, especially in matters of the moral law, even where it concerned kings and was undoubtedly a man of saintly character. In spite of this, popular legend gradually attributed to him the powers of a magician in league with the devil and after some generations his name became a byword. The incident is illuminating because it demonstrates how little the Church was able to prevent such perversions on the part of the people of the real significance of scientific knowledge and original discovery.

The emperor of the transition to the second millennium was Otto III, an orphan brought up by his grandmother Adelheid, assisted by a civil and ecclesiastical council who assumed the government and made every effort to give the boy, who was destined to be the ruler of the larger part of Europe, a fitting education. Nothing shows so clearly how much they valued education, nor how well founded were the ideas with regard to it at this time, than the details of Otto's training as they have come to us. The council thought first about his body, and his physical training was entrusted to Count Hoiko of Saxony. His mental education was begun under Berward, late bishop of Hildesheim, known both as litterateur and artist, and famous for his interest in schools of the arts and crafts. To him the Bernward Cross and other beautiful objects of high artistry are due. Later Otto's education was entrusted to the famous Gerbert, deservedly considered the greatest scholar of the period. Special provision was made for the teaching of Greek to the young prince, and John of Calabria, where Greek was still a spoken language, was chosen for this purpose. These measures were so successful that Otto III as a young man received the title of "wonder of the world." When he reached the age of 15 he assumed the imperial power, and his tutor, Gerbert, took the occasion to remind him "how much had been given to him and therefore how much must be expected of him; by Divine Providence he was by birth a Greek (his mother was Theophano, the daughter of the Byzantine Emperor, Romanus II), by dominion a Roman, and that he had inherited the treasures of Greek and Roman wisdom; as a monarch he was obeyed in Germany, France and Italy as well as by the Slavs, and that he wore the greatest crown in the world."

Young Otto as he approached the age of 20 had high aspirations and dreams of restoring the ancient glories of Rome so as to make it the capital of his empire and to surround it

with the magnificent circumstance of the Byzantine court. Personally, however, he exhibited a humility in striking contrast to his position as a monarch and his talent as a scholar. He proclaimed himself the "slave of Jesus Christ and his Apostles," and on his visit to Rome insisted on spending a fortnight in the catacombs of the great church of Saint Clement in fasting and prayer. He spent some time in the cave of Saint Benedict at Subiaco in order to testify his admiration for the man who had begun the organization of modern civilization in the trying times of the transmigration of the nations, but also in order to ask for help in his own work as he looked forward to it of turning the attention of the world to higher things.

Unfortunately neither of these men was destined to live long to influence the new millennium. The young Emperor Otto died 23 Jan. 1002, and Gerbert followed him to the grave on 12 May 1003. "Short as was his life and few his acts, Otto III is in one respect more memorable than any who went before or came after him. None save he desired to make the seven-hilled city again the seat of dominion, reducing Germany and Lombardy and Greece to their rightful place of subject provinces. No one else forgot the present to live in the light of the ancient order; no other soul was so possessed by that fervid mysticism and that reverence for the glory of the past whereon rested the idea of the mediæval empire." (Bryce, 'The Holy Roman Empire'). Thus opened the second millennium.

Otto III was the last of the Ottos, and as he died unmarried three claimants to the throne brought confusion and warfare to the world of the time and opened a century that was to be full of war. Henry II the Saint who succeeded was the last of the Saxon emperors. His reign is a bright spot in the century and after him the crown passed to the Franks in the person of Conrad II who reigned for some 15 years and then was buried in the cathedral of Spire which he had founded. After him came Henry III and then Henry IV who succeeded to the empire at the early age of six years and is known in history for his recurring quarrels with Pope Gregory VII.

It is not surprising to find that a century which opened thus auspiciously for the intellectual life in its greatest representatives should have witnessed the development of what is practically the first university of modern times, that of Salerno. It was founded around a medical school largely under the influence of the Benedictines whose mother house of Monte Cassino was not far away. The greatest teacher of this century was Constantine Africanus who afterward became a Benedictine, withdrawing to Monte Cassino. According to an old document published by De Renzi in his 'Collectio Salernitana' it is definitely recorded that the school was founded by four doctors, a Greek, a Saracen, an Arab and a Jew, each of whom lectured in his native language. This is probably only a tradition invented to account for the wide interest in the school. The Greek influence as is not surprising here in southern Italy, which used to be called Magna Græcia, was the strongest. As has been pointed out by Gurlt in his 'History of Surgery,' the writ-

ings of the Salernitan physicians contain Grecisms and not Arabisms. The influence of the Arabs was comparatively slight and was due entirely to the fact that certain of the old Greek authors were available only in Arab translations and this gave Arab physicians a certain prestige. The medical school at Salerno became so famous that it attracted students and patients from even distant parts of Europe and Duke Guiscard sent his son Bohemund to Salerno for the cure of a wound which had refused to heal under the ordinary surgical treatment of the time. Robert, the son of William the Conqueror of England, is said to have passed some time in Salerno for a similar reason. From very early in its history Salerno not only permitted, but seems to have encouraged, women medical students, and the department of women's diseases was placed entirely in their charge. As a consequence of the high standards maintained in medical education at Salerno the king of Sicily issued rather stringent laws with regard to the regulation of the practice of medicine "for the protection of the subjects of our kingdom from the dangers arising from the ignorance of practitioners." The development of the history of medicine in recent years has shown that the Salernitan School made magnificent achievements in surgery and that its favorite remedial measures were fresh air, good food, water internally and externally and rest. The 'Regimen Sanitatis Salernitanum,' the little book of abstracts from the medical advice of the teachers at Salerno, written originally just before the close of the 11th century, was for centuries the most popular medical book in Europe. It has been printed in more than 300 editions since the invention of printing and has been reprinted in most of the modern languages in our time.

The important political events of the century were due to the continuation of the incursions of the Northmen. King Aethelred II. "The Unready," had tried at the end of the 10th century to buy off the Danes from further invasions of his territory in England, but the 10,000 pounds of silver only whetted their appetite for conquest. A second and third ransom were no more effective, and then an organized massacre of the invaders (1002), in which the Saxons tried to repay all the cruelty of their oppressors, only prompted organized reprisals. Sweyn invaded England time after time, and finally (1013) assumed the title of king of England. Edmund Ironside, son of Aethelred, fought with a heroism that has made his name forever memorable, but in vain. Canute after Edmund's death (1016) established the Danish rule, and as he was the monarch also of Denmark, Sweden and Norway as well as of most of Scotland, had an imperial domain. He proved an excellent ruler once he had securely established his power, and the familiar incidents related of him, as when he showed his flattering courtiers how little his power really was on the seashore, is typical of the man. He made a visit to Rome, organized the government of his states and well deserves a place among the great rulers of history. His death was the signal for internal dissensions in his empire and it was not until rebellions had been put down that Hardicanute succeeded him.

The Irish suffered also from the invasions

of the Danes, but the Northmen were definitely defeated by Brian Boru at the great battle of Clontarf not far from Dublin, 1014. Brian had secured his place of High King by previous defeats of the Danes and gave the example of military success as a claim for the position of ruler with very unfortunate effects during the next two centuries. Brian himself and his son and grandson were killed at the battle of Clontarf, and after this Ireland was plunged into internal dissensions.

England was destined to have a quarter of a century of peace and goodwill in the reign of Edward the Confessor who on Hardicanute's sudden death in 1042 was called by acclamation to the throne, at the age of about 40. There were no wars except to repel an inroad of the Welsh and to assist Malcom III of Scotland against Macbeth the usurper. Edward devoted himself to the welfare of his people. His royal patrimony sufficed for even his generous donations to the poor and for religion without taxes. "The good Saint Edward's laws" were often demanded by the English of subsequent generations in times of oppression. In their affection and reverence for him the people came to be touched by his hands in certain ailments and so "the King's Touch" became a tradition for English royalty.

For the west of Europe the significant event of the century was the Conquest of England by the Normans, 1066. The duchy of Normandy, the district at the north of France which had been given over to the sea rovers from the Scandinavian countries in the hope thus to create a barrier against further invasion, had been growing in power and prosperity for several generations. William the Conqueror became one of the most important sovereigns by his acquisition of England. He led some 60,000 soldiers of fortune on the expedition. Emerson in 'English Traits' sums it up as "these founders of the House of Lords were greedy and ferocious dragoons, sons of greedy and ferocious pirates." The English people had given the crown to Earl Harold, "the Last of the Barons," but on the strength of a promise made by King Edward the Confessor, who was through his mother a kinsman of the Duke of Normandy, William claimed the throne. The English King Harold found himself compelled to defend himself against Harold Hardrada, king of the Northmen, so that he had two enemies to contend with. He defeated Harold of Norway, but was himself defeated and slain in the famous battle of Hastings or Senlac. The English still opposed the Normans after the victory but William succeeded in spreading his dominion over the country and the opposition, often fomented for the purpose, only served to give excuses to get the large estates and the highest offices in England into the hands of Normans and those on whom he could depend to support him in his policy. The Norman dynasty and its descendants have since ruled England. Britain which up to this time had been outside the circle of European affairs was now drawn into Continental politics. With a ruler who had domains on the Continent nothing else could well have happened. Royal claims on various parts of France embroiled England in war for centuries. Conflicts between sovereigns and various petty rulers continued to be constant

during the century. More and more the nobility refused to acknowledge obligations to their feudal lords in the matter of abstaining from war, and private wars of various kinds became almost the rule. As a consequence, the religious and intellectual life as well as the commercial and agricultural life of the people suffered severely. Feudalism at the beginning of the 11th century had broken down as an instrument for maintaining peace. It is interesting then to see what was accomplished, and how successfully, to put an end to this state of affairs. It is almost the last place at the beginning of the second millennium of modern history to find a great movement for peace, but here it is.

In order to save bloodshed and protect people generally, the Church succeeded in bringing about the introduction of the "The Truce of God." Councils of the Church early in the 11th century forbade hostilities from Saturday night until Monday morning. This prohibition was subsequently extended to other days in the week, and Friday in honor of the Passion and Saturday the day of the Resurrection were declared illegal for military or judicial contests. About the middle of the century ecclesiastical regulations made it unlawful to fight during Lent and then during Advent. The Truce was first successfully proclaimed in France and spread to Italy and Germany to the great advantage of the people of the time. The Truce required that people were to be allowed to go quietly to and fro on their business without being disturbed by soldiers on the designated days and special regulations were issued protecting the peasant and his cattle and his agricultural implements. Before this councils had proclaimed the Peace of God which protected consecrated persons, places and times from warlike invasion. This protection was extended to the poor, pilgrims, Crusaders, and eventually even merchants on a journey. The further development in the Truce of God gave the impetus to peace which was finally taken up by the public authorities, through leagues for the enforcement of peace, and municipal federations until war was restricted to international conflict.

One of the most noteworthy features of the history of the 11th century is its interest in architecture. This began at the very beginning. "About three years after the year 1000," said Rodulf Glaber, "the churches were renovated almost throughout the whole world especially in Italy and the Gauls, although the greater part were still in good enough condition not to need repairing." The movement included not only the churches, but also the public buildings of various kinds.

This interest in architecture naturally led to important developments and the creation of that form of architecture called Romanesque, which was to prove only a step but a very great one toward the magnificent Gothic architecture of the later Middle Ages. The supreme examples of Romanesque are the cathedral of Speyer, finished in 1030 as a mausoleum for the so-called Salian emperors; the cathedral at Treves or Trier, planned and conceived toward the end of the century; the new cathedral of Mainz, which followed the one erected by Willigis the Regent (who saved the empire from disintegration during the minority of the

Emperor Otto III), but which was unfortunately burned down on the day of its consecration, but was immediately rebuilt and completed by Bardo von Oppertshafen in 1037. This Romanesque cathedral of Saint Martin at Mainz is one of the most interesting monuments in the history of architecture and has been the fruitful source of ideas for architects in our generation. The limitation of the width of the Gothic nave makes Gothic churches less suitable for preaching to large crowds, and so even Boston and New York chose to have great churches modeled on Romanesque lines.

The 11th century witnessed some precious social development, especially in the establishment of hospitals, which at that time were not only for the ailing poor, but also for the crippled and needy of many kinds as well as lodging for strangers. Archbishop Lanfranc erected a series of hospitals and "the good Queen Maud," the wife of Henry I, who was the daughter of Saint Margaret of Scotland, acquired a special repute in connection with her care for the ailing poor. King Henry, after the death of his son by drowning in the famous incident of "the White Ship," caught something of his lady's spirit, and Matilda, their daughter, followed their example. The lepers particularly were cared for, and the beginning of the eradication of this disease, said to be as common then as tuberculosis is with us, was made through segregation, the hardships of which were mitigated to no inconsiderable degree by the lively interest of royalty and the nobility in the afflicted and the spirit in which their ailment was taken.

The 11th century saw the beginning of the organization on a broad scale of the Christian nations against Mohammedanism. The first active reaction against them in the countries where they had maintained themselves for some centuries came in Spain where the Moors in possession since early in the 8th century felt themselves at home. Just about the beginning of the 11th century the three Christian kingdoms—Castile, Aragon and Navarre—began to play a rôle of importance in the northern part of Spain. Castile led the movement, and before the end of the century had reconquered Toledo. The rivalry between the Christian countries hampered their progress for a time, but they grew stronger by the intermarriage of their royal houses and were able to advance their frontiers at the expense of the Moors. Aragon took possession of Barcelona and the valley of the Ebro. Nearly 500 years of struggle remained however before the Moors were finally expelled. The advantage to Spanish character of the ceaseless contest was seen in the rôle played by the Spaniards in the New World after its discovery and the magnificent development of Spanish power at home and abroad which followed the final expulsion of the Moors in 1492.

The great hero of the century is Ruy or Rodrigo Diaz de Bivar, known as The Cid (Arabic, master) or *El Campeador* (Spanish, the champion or challenger). His life fills the whole of the second half of the century and his exploits animated the Spaniards against the Moors for all the centuries afterward until their complete expulsion. The romantic chronicle of 'The Cid' the substance of which was compiled by Alfonso the Learned only half

a century after the hero's death contains much that is literal history, and the obviously legendary incidents can be rather readily eliminated. Southey's translation made the work familiar in English. The *Cid* of the romances is another creature entirely, quite as much the nucleus for myths as Charlemagne's Paladins or King Arthur and the Knights of the Round Table. Undoubtedly Rodrigo's real victories apart from all romance form the core of Spanish history at the time.

The other phase of Christian opposition to Mohammedanism is also the greatest event of the 11th century, the first Crusade. Jerusalem had fallen into the hands of the Arab Mohammedans shortly after the death of Mohammed in the 7th century. This Semitic race shared in the Christian reverence for the Holy Places and permitted the Christian pilgrims who came in large numbers during the Middle Ages to pursue their devotions without molestation. In the 11th century, however, the Seljukian Turks, reconquered long before by the caliphs, now invaded the caliphate as the Germans the Roman Empire, replaced the Arabs as the rulers of Jerusalem and at once initiated a very different policy toward the Christians. Great hardships were inflicted upon the pilgrims, and the stories of the cruel ties imposed aroused the feelings of Europe. The Seljuks, continuing their victorious career, defeated the Eastern Empire in 1071 and thus became rulers of Asia Minor. They took possession of Nicæa, just across the straits from Constantinople, and Europe itself was menaced. Pope Urban II, whose training as a churchman had come under Pope Gregory VII, after six years of wandering from the time of his election had, in 1094, at last succeeded in gaining entrance to Rome and set himself to the task of unifying Christendom. In spite of rather serious breaks with the Emperor Henry and King Philip of France who had repudiated their wives, Urban devoted himself to the great problems of arousing Christianity against the Turks.

The first incentive to the Crusades has often been attributed to Peter the Hermit, but it really came from Pope Gregory VII and was popularized by the address of Pope Urban at the Council of Clermont (in Auvergne). After excommunicating Philip of France for adultery in having taken to wife Bertrada, the wife of Fulk of Anjou, the urgent question of the East was taken up. The Council had attracted immense crowds of all classes, but particularly of the nobility and knights. The Pope's address asking for an army to be sent to redeem the Holy Places aroused great enthusiasm, and all present exclaimed with one voice "It is the will of God." The Pope declared that this should be their rallying cry, and all were to wear a cross as a sign of their acceptance of whatever hardships might be involved. It is from this cross that the word crusade is derived. Each participant was "crossed." Pope Urban suggested that particularly those who were in the midst of contentions with brethren and relatives might thus find a holy vocation. Most of those who took up the cross did so out of the highest motives of pure devotion. It would be idle to think that in so great a mass of men there should have been no hypocrites, but they must have been surprisingly few.

In his great-heartedness the Pope proposed that those who had been robbers and brigands might now become soldiers of Christ with the feeling that here was a chance for the redemption of such men from evil ways, though doubtless also with the conviction that no matter what their motives they could work less harm in the army than at home, and that at any rate all should have their chance in the great cause.

Many privileges were granted to the Crusaders by the Church, and these have sometimes seemed to modern historians violations of justice. The payment of debts for instance could be put off, and the Crusaders were even freed from the payment of interest upon their debts and permitted to mortgage their property for the purposes of the Crusade without the consent of their feudal lords, though this was required by the laws of the time. We in our time who have seen another great World War with its moratoria, its prorogation of rents and notes, its shutting up of stock exchanges and its taking over of the resources of countries, are not likely to misunderstand similar events of the Crusade. Crusaders' wives and children and property were taken under the direct protection of the Church and those who disturbed them found that they had to do with the ecclesiastical authorities. The youth of all the country gave themselves unstintedly to the cause quite as they have in our time and have always done for idealistic purposes. Within a year after the great wave of enthusiasm which had begun at Clermont had spread through Europe there was, according to the Pope himself, some 300,000 soldiers collected under the leadership of the great nobles of the time. If it is recalled that at this period the European countries whose census of population we have, had much less than one-tenth as many inhabitants as in our time, the immensity of the effort thus put forth will be properly appreciated. The important leaders were Godfrey of Bouillon and his brother Baldwin, from Brabant, with Count Raymond of Toulouse who led a great army from Provence. The French troops were not led by Philip, who was in disgrace, but were joined with those of the Normans from southern Italy under the command of Bohemund, the son of Robert Guiscard, and his cousin Tancred who was the son of Otto the Good and of Emma, the sister of Robert Guiscard. Tancred came to be the rival in the later legends of the Crusades even of Godfrey of Bouillon and to be the centre of romances for centuries in modern European life.

After many hardships the army of the Crusaders succeeded in finding its way to Constantinople only to discover that the Greeks expected to turn the great Christian expedition into a military campaign for the benefit of the empire. The Crusaders encamped in the suburbs of the capital not only were not welcomed, but were actually declared enemies because they refused to take the oath of homage to the emperor. Contemporary documents which show the complaints of traitorous cruelty on both sides used to be held up as flagrant testimony to the essential barbarity of the people of the time, but recent experiences have demonstrated that the trait thus disclosed is human and not merely mediæval. The emperor's daughter Anna, writing a history of the times, has made a

document almost as bitter in denunciation of the Crusaders as any that appeared on either side in our own great war. The Crusaders did not hesitate to call the Greeks traitors, cowards, liars and worse, but above all to deprecate their cruelty toward small parties of Crusaders unable to defend themselves. The Byzantines replied with accusations of attacks upon women and children and thieving depredations of various kinds.

It was not until the spring of 1099 that an army of 20,000 Crusaders under Godfrey of Bouillon reached Jerusalem. The Holy City was stormed and taken 15 July 1099. Elected king of Jerusalem Godfrey refused that title in deference to the higher King whose spirit reigned over the world from there, and chose the simple designation of Protector of the Holy Sepulchre. He completed the conquest of the Holy Land by defeating the sultan of Egypt in the plain of Ascalon, 12 Aug. 1099. Godfrey had been wounded during the siege of Jerusalem and died just a year later, 11 July 1100. He was succeeded by his brother Baldwin. Altogether four principalities were created by the Crusaders in Mohammedan territories, the capitals of which were Edessa, Antioch, Tripoli and Jerusalem. Baldwin succeeded in taking possession of Acre, Sidon and some other important towns along the coast of Asia Minor. The news of the fall of Jerusalem caused great rejoicing throughout Europe and brought many accessions to the armed forces of the city's ruler. Unfortunately many of these were lost at sea and many were cut off in various ways by the Turks so that the consolidation of the recent conquests became very difficult. Luckily the Mohammedans were engaged in fighting among themselves and could not combine against the Franks as they called the Crusaders generally. Altogether at the end of the 11th century the Crusaders occupied a small strip of land not 50 miles wide and some 500 miles long from which the Turks were for long unable to displace them.

This was the beginning of the great movement, the Crusades, which was destined to influence Europe so deeply for the next two centuries. There was scarcely a generation until the end of the 13th century that did not witness the going out from some part of Europe of large bodies of men who had nobly taken up the task of securing the possession of the Holy Places to the Christians. In the end they failed of that object and the Holy Land fell once more under the domination of the Turks, but in the meantime an immense amount of good was accomplished. The loss of men in battle and by disease so far from draining the human resources of the countries rather added to them. Men developed new energies. A great surgeon said during the Great War that for every man killed two men were being made. Something like this happened in the Crusades. They aroused men's energies, brought the East and West in contact, broadened men's interests, lessened the power of the nobles, strengthened national feeling and accomplished great good for the race which was manifest in the achievements of the 13th century.

The character of the 11th century most disputed about in history is Pope Gregory VII, whose name Hildebrand has been translated "a bright flame" by those who felt that he ac-

complished wonderful work for Christendom and "a brand of Hell" by those who declared that he was an influence for evil. There is no doubt at all that he exerted a deep influence over his own and succeeding generations. He was a self-made man of lowly birth, one of those who in President Wilson's words make it clear "why government did not suffer dry rot in the Middle Ages under the aristocratic systems which then prevailed . . . there was no peasant so humble, that he might not become a priest and no priest so obscure that he might not become Pope of Christendom and every Chancellor in Europe was ruled by those learned, trained and accomplished men."

As Pope he took up at once the reform of Church matters and the definite regulation of the relations of the Church to the State. By abuse bishops had come to be almost more state officials than Church dignitaries. Gregory labored to have them independent in their ecclesiastical functions except of the head of the Church, but it was difficult to correct long standing abuses. The most serious contest in this matter is between Pope Gregory and the Emperor Henry IV of Germany. Hildebrand dissolved the oath of allegiance of Henry's subjects and the nobility, glad of the opportunity to put down a tyrant, fell away from him and made Henry realize that unless he regularized his relations with the Church he could not hope to continue as a ruler. After many attempts to avoid the humiliation Henry made the famous journey to Canossa to be reconciled with the Pope, when he was required to do penance so severe that Hildebrand's conduct in this matter has often been censured. But Hildebrand maintained the rights of the Church as he saw them and continued to purify the Church itself of abuses of various kinds and to uphold the moral law as binding upon rulers as well as the people. Reformers are not likely to be popular and Gregory was in constant trouble. His own last words sum up his life better than any others. He had been compelled to leave Rome and was dying in Salerno when he said "I have loved justice and hated iniquity, therefore I die in exile."

Hildebrand both before and after his election as Pope did more than anyone else to lay that foundation of the ascendancy of the Papacy in Europe which culminated a century later in the pontificate of Pope Innocent III. During the time when popes were looked up to as guardians of the moral conscience of Europe, the best historians admit that there was a magnificent development of culture in the best sense of that word. Few if any epochs in the whole history of mankind present achievements higher than those of the 12th and 13th centuries. The loftiest aspirations of mankind were finely fostered. Beautiful architecture, painting that has never lost its interest, magnificent hospitals and great literature, charming arts and crafts all developed at this time and have come to be the loving study and reverent admiration of our generation. If a career is to be judged by its fruits, Hildebrand's influence in making the popes a moral centre as well as ecclesiastical power in Europe must be considered one of the great factors for a great era of human development.

A great scholar of the 11th century whose works are still republished in many languages

and whose influence continues to be felt is Anselm, archbishop of Canterbury. His little book, 'Cur Deus Homo,' is still frequently read by those who are deeply interested in the philosophic side of Christianity and his 'Monologium' and 'Proslogium' are well known by philosophic students. He was one of the most important links in the chain of philosophic thinking known as scholasticism, which has had a very interesting and significant revival mainly through Cardinal Mercier in our own generation. Though Anselm was the archbishop of Canterbury and had been the abbot of Bec in Normandy, he was neither Norman nor Saxon, but Italian, born in 1033 near Aosta. His father was a simple citizen of the little town and Anselm owed his rise entirely to his own abilities. He entered the abbey of Bec as a young man just when it had been made famous by the learning of Lanfranc and three years later became prior and filled that office and that of abbot for some 30 years when he was made archbishop. He succeeded Lanfranc as archbishop of Canterbury under most difficult circumstances, refusing the archbishopric at first as he had refused the election of abbot and consenting to be honored only when it was made clear to him that he could probably do great good in the new office. Lanfranc had had serious difficulties with the king over the matter of investiture and Church revenues and Anselm inherited these. He succeeded in finding a mode of compromise and laying down the principles on which the relations between the Church and State could be safeguarded without violation of the rights of either. Historians have recognized the genius and character of the man, and Freeman did not hesitate to say "stranger as he was he has won his place among the noblest worthies of our Island." Curiously enough Anselm's contribution to the borderland between philosophy and theology, the ontological argument for the existence of God put forth in his 'Proslogium,' was revived in modern times by Descartes, became the cardinal point of difference between Kant and Hegel at the end of the 18th century, to be revived by Rosmini in Italy and adopted by Brownson in America in the 19th century. An argument that sways such minds all down the centuries must surely have in it something that has a deep appeal to some essential quality of the human intellect apart from training and environment.

The rise of the Seljukian Turks gave a period of peace in Persia under the viziers of Toghrul Beg and his son and grandson, Alp Arslan and Malik Shah, during which a series of contributions of enduring interest to the intellectual life of humanity were made. At the beginning of the 11th century Abul Kasim Mansur of Tus in Persia (d. 1020), known as Firdusi or Firdausi "the Paradisiac," finished the *Shahnamah*, the great Persian epic of about 60,000 distichs, which sings the deeds of Persian heroes and rulers for 500 years. A little later Avicenna, "the prince of physicians" (d. at Hamaden, Persia, 1037), "at once the Hippocrates and the Aristotle of the Arabians" (Whewell) wrote the books that for five centuries influenced medicine in Asia and Europe more than any others. They are only compilations of Hippocrates and Galen, but when Greek was no longer known they served as sources of

ancient knowledge for a great many writers. Avicenna's work is typical of much of what the Arabs did. There is little of originality, he was merely a channel for the older medical writers and for Aristotle. The second half of the century Al Gazali (b. at Tus 1058) was for a time professor of Mohammedan theology in the school at Bagdad. In his earlier years some of his writings were sceptical and these have a special appeal to the moderns, but later he became the greatest of Mohammedan apologists and continued to be studied for long afterward. Omar Khayyam, the Persian poet-astronomer, whose 'Rubaiyat' attracted so much attention at the end of the 19th century was the fourth of these Mohammedan writers destined to an enduring influence. He corrected the calendar successfully and wrote books on algebra and astronomy, but these have had no influence beyond a generation or two in its own time, while his quatrains on life and death and love and God and the problems men face forever, struck off at idle moments, caught the vein of thought of the distant Western peoples eight centuries later. He had been the schoolmate of the vizier of Alp Arslan, and the third of a little trio who at school swore eternal friendship and to share whatever fate might bring them was the notorious Hasan, "the Old Man of the Mountains," from whose name because of his infamous deeds very probably the word "assassin" in our modern languages is derived. Manifestly Omar's experience of life and its vicissitudes in person and through his friends was ample to enable him, if he had the mind to, to write of humanity's problems with fullness of knowledge.

There are two great women of the century whose names are still well known and lives of whom have been written in our generation. One of these was Matilda of Canossa, Countess of Tuscany and heiress of the Marquess Boniface of Tuscany. She knew Latin well, was fond of serious books, took a deep interest in the philosophical and religious discussions so common at the time and came to exert an immense influence, not only in Italy but throughout Europe. She was a great personal friend of Hildebrand before his election to the Papacy as Gregory VII, and constantly supported him in the conflicts which his reforms involved. It was in letters to the Countess and her mother that Pope Gregory discussed the question so dear to his heart of the organization of the Crusade for the winning back of the Holy Land. It was at her castle of Canossa that Pope Gregory received the repentant Emperor Henry. At her death Matilda bequeathed her estate in central Italy to the Church, feeling the necessity of strengthening the Pope's political situation and this bequest was confirmed by the Emperor Frederick II.

The other great woman of the century was Margaret of Scotland, whose life runs almost parallel with the second half of it. She was intimately related to many of the well-known characters of the time. She was the granddaughter of Edmund Ironside, and when exiled under Canute spent some years with King (Saint) Stephen of Hungary. She returned to be close to Edward the Confessor for a time, but, with her mother, set out for France



when the Normans won the battle of Hastings. Their ship was driven by storm to Scotland where Malcom III, having defeated Macbeth, was king. Margaret became his wife and did so much to soften the barbarous manners of the Scotch that ever since she has been in benediction. A favorite occupation was the securing of justice for the poor and a stone is still pointed out near Edinburgh, called Saint Margaret's stone, on which she sat to hear their causes. Her favorite son David is the Saint David of Scottish history, and the building of great churches and monasteries was initiated by Margaret. She was untiring in zeal for education and for the encouragement of book-making and is looked upon by the Scotch as one of the great founders of their civilization.

JAMES J. WALSH,  
*Author of 'The Thirteenth, the Greatest of Centuries.'*

#### PRINCIPAL EVENTS OF THE ELEVENTH CENTURY.

- 1001. The Eastern Empire loses territory to the Bulgarians and is attacked by the Russians.
- 1002. Emperor Otto III of the Western Empire dies.
- 1003. Pope Sylvester II previously known as Gerbert, the greatest scholar of the age, dies.
- 1013. Danes conquer England.
- 1014. The Irish under Brian Boru defeat the Danes at Clontarf.
- 1017. Canute, king of Scandinavia, becomes king of England.
- 1042. Edward the Confessor reigns over England.
- 1060. The Normans invade Sicily.
- 1066. The Norman Conquest of England. William the Conqueror reigns; institutes feudalism; forest laws; the Domesday Book.
- 1071. The Turks defeat the Eastern Empire, occupy Asia Minor and threaten Constantinople.
- 1076. The Turks capture Jerusalem.
- 1077. Henry IV of Germany does penance at Canossa for disobedience to Pope Gregory VII.
- 1087. The Moors enter Spain to assist the Arabs and Saracens.
- 1094. Ruy Diaz de Bivar the Castilian Cid Campeador defeats the Moors and becomes lord of Valencia, Spain.
- 1094. Urban II after six years of wandering re-enters Rome and actively engages in uniting Christendom.
- 1095. The European Truce of God proclaimed at the Council of Clermont by Pope Urban II.
- 1095. Peter the Hermit stirs Europe to save Jerusalem from the Turks. Celibacy enjoined.
- 1096. The First Crusade.
- 1099. Christian Crusaders capture Jerusalem.

**ELF-ARROWS, ELF-BOLTS, ELF-SHOT**, are the names given to implements of stone, especially flint, of various sizes and forms, which are found abundantly in many countries, and are the remains of arrow-heads, darts and other rude ancient weapons from the Palæolithic period. They belong to the same class of ancient implements that are generally known as Celts (stone hatchets). These rude and ancient implements are objects of some extraordinary superstitions. The names given above are, of course, of popular and comparatively modern origin, and imply that those who gave them were completely ignorant of the real origin and use of those weapons. These names are found independently among the peasantry in Scotland, England and Ireland, and the superstitions associated with them are much more widely spread. According to the popular belief the stones are of supernatural origin, and various virtues are attributed to them. They are worn as charms, and used as a protection against lightning; but they are chiefly suspected of mischievous consequences. A cavern has been pointed out where the archfiend carries on the manufacture with the help of attendant imps, who rough-hew them while

he finishes the work. Similar superstitions prevail in Italy, Africa and Turkey. Consult Evans, 'Ancient Stone Implements of Great Britain.'

**ELGAR, SIR Edward William**, English composer: b. Broadheath, Worcestershire, 2 June 1857. Among his compositions are 'The Black Knight' (1892); 'Choral Suite: from the Bavarian Highlands' (1895); 'Lux Christi,' produced at the Worcester Festival (1896); 'Te Deum,' sung at the Hereford Festival (1897); 'Caractacus,' produced at the Leeds Festival (1898); 'Sea Pictures,' for the Norwich Festival (1899); 'Dream of Gerontius,' for the Birmingham Festival (1900), which is considered his masterpiece. It was reproduced at the Niederrheinische Musik Fest in 1902. Other of his compositions are 'Coronation Ode' (1902); 'The Apostles' (1903); 'The Kingdom' (1906); 'Coronation March' (1911); a masque, 'The Crown of India' (1912); 'The Music Makers' (1912); 'Falstaff,' a symphonic study (1913), and 'Carillon' (1915). Besides these he has written symphonies, several concert overtures and a violin concerto.

**ELGIN, James Bruce, 8TH EARL OF, and 12TH EARL OF KINCARDINE**, English statesman: b. London, 20 July 1811; d. Dhurmsala, North India, 20 Nov. 1863. He was educated at Eton and Oxford; in 1841 entered Parliament as member for Southampton, and in the same year succeeded to the earldom. In 1842 he was appointed governor of Jamaica. His rule in Jamaica was so successful that in 1846 he was appointed governor-general of Canada, and there he succeeded by a conciliatory policy in allaying the discontent which had broken out and for some time continued. It was through his efforts that reciprocity between the United States and Canada in natural products was established (1854-66). In 1849 he was raised to the British peerage as Baron Elgin; was sent in 1857 as special ambassador to China, where in the following year he succeeded in concluding the Treaty of Tientsin. He also concluded a treaty with Japan. When he returned to England he was given the office of Postmaster-General and elected lord rector of Glasgow University. In 1860, the Chinese emperor having manifested unfriendliness, Lord Elgin was sent to enforce the treaty, which he did by seizing Peking. The treaty which followed was successful in regulating Chinese relations with Europe until 1890. In 1861 he was appointed governor-general of India. He maintained internal peace and exerted himself unceasingly for the development of the country. His 'Letters and Journals' were edited by Walrond (London 1872).

**ELGIN, Thomas Bruce.** See **ELGIN MARBLES.**

**ELGIN, Victor Alexander Bruce, 9TH EARL OF**, British statesman: b. Montreal, 1849; d. Scotland, January 1918. His grandfather, the 7th earl, best known by his connection with the Elgin Marbles (q.v.), was British Ambassador at Constantinople from 1799 to 1802. Lord Elgin was educated at Eton and Oxford and entered Parliament as a Liberal under the banner of Gladstone. In 1893 he was appointed viceroy of India, a post which his father had held — and

died in—30 years before. The five years of Elgin's administration, 1894 to 1899, were marked by numerous and serious problems, financial, economic, plague, famine and war. The difficulties were met by the viceroy and his advisers with courage, resource and success, and much was done to improve public works in general and railroad construction in particular. Lord Elgin was chairman of the royal commission appointed in 1902 to inquire into the military preparations for, and conduct of, the South African War. In the Campbell-Bannerman Cabinet (December 1905) he became Colonial Secretary, in which capacity he was primarily responsible for framing the Constitution for the Union of South Africa. He retired in 1908, but his services were employed on important government commissions where judgment and impartiality were needed. As chairman of the Carnegie Trust he took a strong interest in the application of the fund. Lady Elgin, who died in 1909, had six sons and five daughters.

**ELGIN, Ill.**, city of Kane County, 36 miles west by north of Chicago, on the Fox River. Two railroads supply adequate shipping facilities, the Chicago, Milwaukee and Saint Paul and the Chicago and Northwestern. It is also the terminus of the Aurora, Elgin and Chicago Railway, which is a third-rail electric line between these cities. Two products make Elgin famous—butter and watches. The dairy interests have probably had more to do with the development of the community than any other factor. Early in its history, The Borden Condensed Milk Company located a large plant here and since that time has established many more in the immediate vicinity. The current quotations of the Elgin Board of Trade fix the market price of high grade butter throughout the entire country. The other industry to which Elgin largely owes its growth and prosperity is the making of fine watch-movements. The watch factory was started in the spring of 1864 and has been a success from the beginning. There are many other industries in Elgin, all of which are prosperous concerns. Two watch-case factories and as many shirt factories distribute their products throughout the country. Besides these, there are shoe, pipe-organ, silver-plate, automobile, coffin-fixtures, canning, malted milk, rug factories, foundries, flouring mills, etc. Two large publishing houses are located here and there are several machine shops and foundries. The United States census of manufactures for 1914 showed within the city limits 91 industrial establishments of factory grade, employing 5,974 persons; 5,529 being wage earners, receiving annually \$3,320,000 in wages. The capital invested aggregated \$17,371,000 and the year's output was valued at \$10,492,000; of this, \$6,221,000 was the value added by manufacture. Elgin is sometimes called the "City of Churches." Nearly all denominations are represented and the various houses of worship are large and handsome. The city is noted for its public school system, which is highly developed and very efficient. The buildings are handsome in architecture and a new high school is in the process of construction. The Elgin Academy of the Northwestern University is a well-known preparatory school for the latter institution, which is located at Evanston, Ill.

Saint Mary's Academy is also well known throughout the State and bears a high reputation as a place of learning. The Illinois Northern Hospital for the Insane is located in Elgin. The Elgin Woman's Club has built and operates a large hospital, which is famed throughout the country and State for its high standing and great efficiency. Its cost was about \$1,000,000. The banks are six in number, four national and two savings. They have a combined capital of over \$650,000 and are prosperous and strong financial institutions. Founded in the spring of 1835, Elgin has grown rapidly in size and importance until it now is the most beautiful and the second largest city in Kane County. Elgin was incorporated in 1854 and Dr. Joseph Tefft was chosen the first mayor. The waterworks and sewer system and an electric-lighting plant are the property of the municipality. The city has commission form of government. Property is in demand, owing to the number of Chicago people who, on account of good transportation facilities, are seeking more room and pleasanter homes within the confines of the beautiful city on the Fox River. Pop. 27,485.

**ELGIN MARBLES**, the name given to a peerless collection of antique sculptures brought from Athens to England by Thomas Bruce, 7th Earl of Elgin, in the early part of the 19th century. While Ambassador at Constantinople (1799-1802) he conceived the plan of securing some portion of the ruins of ancient Athens and to that end secured permission of the Porte to take "any stones that might appear interesting to him." At his own expense (the British government having refused aid) he set a corps of artists to work who toiled for 10 years detaching various specimens from the Parthenon, consisting chiefly of the colossal statues on the tympana of the pediments, the metopes and the frieze around the cella. Among the best preserved examples which this splendid effort brought forth were the tympanum representing the birth of Minerva, the 15 metopes showing in high relief the combats of the Centaurs and Lapithæ and the slabs from the cella frieze depicting in low relief the great Panathenaic procession. In addition to these Lord Elgin procured the colossal statue of Bacchus from the choragic monument of Thrasylus, one of the caryatides from the temple of Pandrosus, a portion of the frieze from the Erechtheum and fragments of the columns of the Parthenon and Erechtheum; also numerous inscriptions, urns, etc., found in the neighborhood. When these treasures of antiquity arrived on the English shores they were received with a mixture of admiration and indignation—the latter because of supposed vandalism. It is said that Lord Byron was so outraged by the alleged depredations that when he visited the Parthenon he inscribed conspicuously: *Quod non fecerunt Gothi, hoc fecerunt Scoti*. However, as it afterward proved, had not Lord Elgin obtained these sculptures they would have been destroyed in the subsequent war of Greek independence and especially in the last siege of Athens in 1826-27. After much hesitation and bickering as to the price, in spite, too, of their value vouched for by experts, the British Parliament purchased the marbles from Lord Elgin for £35,000, easily a

third less than he had expended upon them. They are now to be seen in the British Museum as priceless examples of the highest in Greek art which matured under the genius of Phidias. Many casts have been taken of these unsurpassed relics of which the city of New York possesses a set. Consult 'Ancient Marbles in the British Museum' (Vols. VI-IX, London 1830-39, 1842).

**ELHORST, Hendrik Jan**, Dutch biblical scholar: b. Wisch, Guelderland, 1861. He received his education at the University of Amsterdam. He entered the Mennonite ministry and held pastorates successively at Insum, Friesland, Arnhem, The Hague and Haarlem. In 1906 he was appointed to the chair of Hebrew language, antiquities and literature in the University of Amsterdam. He has published critical commentaries on Micah (1891), Amos (1899) and 'Israel in Thet lichte der jongste onderzoekingen' (1906).

**ELI**, ʿēlī, Hebrew judge and high-priest of Israel. After a turbulent rule of 40 years, he died 1116 B. C. Failing to punish the misdoings of his sons, Phineas and Hophni, the downfall of his house followed.

**ELI PERKINS**. See LANDON, MELVILLE DE L.

**ELIA**, ʿēlī-ā. See LAMB, CHARLES.

**ELIE DE BEAUMONT**, a'lē de bō-môn, **Jean Baptiste Armand Louis Léonce**, French geologist: b. Canon, France, 25 Sept. 1798; d. there, 22 Sept. 1874. He was educated in the Polytechnic School; became professor at the School of Mines (1829); professor of geology in the College of France (1833); chief engineer of mines (1833); member of the Institute (1835) and perpetual secretary of the Academy of Sciences (1853). He published 'Carte géologique de France' (1843); 'Notices sur les systèmes de montagnes' (1852); and with Dufrenoy, 'Voyage métallurgique en Angleterre' (1827), the record of a scientific journey he had made in England and Scotland in 1823. His principal services to science were in the establishing of the geological survey of France and the stimulating of interest in mountain geology.

**ELIGIUS**, ɛ-līj'ūs, or **ELOI**, ā-lwā, **Saint**, bishop of Noyon: b. Cadillac, near Limoges, 588; d. Noyon, 1 Dec. about 660. Having in boyhood shown a decided aptitude for fine art he was placed by his parents under the direction of the master of the mint at Limoges and there acquired skill in the goldsmith's craft. Appointed coiner to the Frankish king, Clotaire, and to his son and successor, Dagobert, he executed at their order the bas-reliefs on the tomb of Saint Germanus, bishop of Paris, and other works in the precious metals which were regarded as the masterpieces of decorative art in that time. He was a favorite at court, which he was obliged to frequent because of his connection with the king; but he took more pleasure in relieving the needy than in the society of the worldly. He daily fed a large number of poor people, he buried the bodies of malefactors, and he ransomed captives, especially the Saxon slaves who were often sold in the markets. Both Clotaire and his son Dagobert bestowed costly presents upon Eligius, but they could not make him rich, he gave so much to

the poor and to the founding of charitable institutions. At about the age of 50 he decided to abandon the world entirely and devote himself to the conversion of the pagans. Two years later he was ordained priest and in 546 was made bishop of Noyon. As bishop he gave special attention to the conversion of the Flemings and Frisians, and the greater part of Flanders was converted through his efforts. Consult Lebeuf, 'Histoire du diocese de Paris'; Fleury, 'Vita S. Eligius.'

**ELIHU**, a friend of the patriarch Job, introduced as speaking after the three intimate friends. His portion in chapters xxxii-xxxvii is supposed by many critics to be a later addition to the book. Lightfoot and others conjecture that Elihu was the author of the book of Job.

**ELIJAH**, whose name ("Jehovah is God<sup>h</sup>") indicates his mission and his work, was one of the greatest prophets of Israel. His prophetic activity began in the days of Ahab of Israel, and ended in the days of his son, Ahaziah, or, as is on the whole more probable, in the days of his son-in-law, Jehoram of Judah. His first appearance is strange; the end of his life on earth still more strange. Throughout his career he comes and goes in an unusual and remarkable way. His special work was to save his nation from falling into heathenism, and thus making impossible the great history which has resulted in the Christian civilization of our own days. Ahab, the king of northern Israel, had married Jezebel, the daughter of Ethbaal, king of Tyre, and formerly a priest of the Tyrian religion. Among the Semitic peoples an alliance of nations meant a mutual honoring of gods. Thus the marriage of Ahab and Jezebel introduced into the kingdom of Israel the worship of the Tyrian Baal. Gradually, through the determined efforts of Jezebel, who was a fanatic for her faith, the worship of Baal displaced that of Jehovah, and seemed likely altogether to destroy it. Later, by the marriage of Athaliah, the daughter of Ahab and Jezebel, to Jehoram, king of Judah, the same course of things began in the kingdom of Judah (2 Kings viii, 18). To bring back the nation to the worship of Jehovah, and to the recognition of him as God, was the work of Elijah. This work began with the sudden appearance of the prophet to Ahab, to announce to him the coming drought and famine, which the nature god Baal would be powerless to prevent (1 Kings xvii, 1). The life of the prophet up to this time had probably been spent in the lonely and wild region on the eastern side of the Jordan, although it is uncertain where his birthplace was. During the three years and more of drought and famine which followed Elijah's first appearance to Ahab, the prophet found a home and the means of life, first by the brook Cherith, and afterward in the home of a widow in Zarephath, a city of Phœnicia. At the end of this time he had his great contest with the prophets of Baal on the Mount Carmel, where, in answer to his prayer, Jehovah revealed himself by fire, and was acknowledged by the people to be God. The same day the falling rain ended the drought and the famine (1 Kings xviii). The triumph of the prophet was followed by a flight to Mount Horeb to escape the wrath of the angered Jezebel. On this mountain he received

from God a revelation in regard to the real part his work had in the history of his nation, and was commanded by God to call Elisha to be his successor in the work for the nation. In obedience to this command, he went from Horeb to Abel-meholah, the home of Elisha. Having given to Elisha the call to be his successor, he disappeared for a time from the view of men (1 Kings xix). About six years later, the prophet again appeared to Ahab in the vineyard of Naboth, in Jezreel, to denounce him for his wicked disregard of the rights of his brother, made sacred by the law of Jehovah (1 Kings xxi, 17-24). The final work of the prophet on behalf of his people is recorded only in the book of Chronicles (2 Chron. xxi, 12-15). This was the sending of a letter to Jehoram, the king of Judah, to tell him that, because he had endeavored to introduce the Baal worship of the northern kingdom into Judah, and because he had cruelly murdered his brothers to make his own throne more secure, Jehovah would send great evils upon his people, his family and himself. How long the prophet lived we do not know (2 Kings li, 1-12). Consult Milligan, 'Elijah: His Life and Times' (in 'Men of the Bible'); Farrar, 'First Book of Kings' (Chaps. xxxiii-xlviii, in the 'Expositor's Bible' 1893); and 'Second Book of Kings' (in the same, Chaps. i and ii, 1902); Strachan, 'Elijah' (in Hastings' 'Dictionary of the Bible,' 1899).

SYLVESTER BURNHAM,  
*Professor of Old Testament Interpretation,  
Theological Seminary of Colgate University.*

**ELIJAH**, The, an oratorio by Mendelssohn, first performed at Birmingham, England, 26 Aug. 1846. It is one of his best-known works and is more popular in England and America than any other oratorio, with the exception of Handel's 'Messiah.'

**ELIMINATION**. In mathematics we often meet with instances where, given several statements concerning several distinct quantities, we wish to discover precisely what is affirmed of a smaller group of these quantities. For example, in the solution of simultaneous equations, such as

$$\begin{cases} a_1x + b_1y + c_1 = 0 \\ a_2x + b_2y + c_2 = 0, \end{cases}$$

to obtain the value of  $x$ , we must derive from these two equations a single one not involving  $y$ . This process is called the *elimination* of  $y$ . In the case of linear simultaneous equations such as the above, the elimination may be performed by multiplying the first equation by  $b_2$  and the second by  $b_1$  and, subtracting or by solving the first equation for  $y$  and substituting this value in the second, or by solving both equations for  $y$  and equating the values thus obtained. All these methods give the result

$$x = - \frac{\begin{vmatrix} a_1c_1 \\ a_2c_2 \end{vmatrix}}{\begin{vmatrix} a_1b_1 \\ a_2b_2 \end{vmatrix}}$$

(see DETERMINANTS), and throughout all forms of elimination determinants are very convenient.

Elimination between equations not linear is apt to be very complicated and difficult. However, in the case of the elimination of a single unknown from two consistent algebraic equa-

tions, Sylvester's dialytic method forms an easy solution to the problem. This consists in obtaining from two equations in  $x$  of the  $m$ th and  $n$ th degrees, respectively, the  $n$  equations formed by multiplying the first equation by the powers of  $x$  from the 0th to the  $(n-1)$ st and the  $m$  equations formed by multiplying the second equation by the powers of  $x$  from the 0th to the  $(m-1)$ st, and by eliminating from these the powers of  $x$ , considered as independent variables. We thus get  $m+n$  equations in  $m+n-1$  variables, and the condition (see DETERMINANTS) that these be consistent is that the determinant of the coefficients should vanish. For example, if our two equations are

$$\begin{cases} a_1x^4 + a_2x^3 + a_3x^2 + a_4x + a_5 = 0 \\ b_1x^3 + b_2x^2 + b_3x + b_4 = 0 \end{cases},$$

we obtain from these the equivalent family of equations

$$\begin{cases} a_1x^4 + a_2x^3 + a_3x^2 + a_4x + a_5 = 0 \\ a_1x^3 + a_2x^2 + a_3x + a_4 = 0 \\ b_1x^3 + b_2x^2 + b_3x + b_4 = 0 \\ b_1x^2 + b_2x + b_3 = 0 \\ b_1x + b_2 = 0 \\ b_1 = 0, \end{cases}$$

which give the relation between the coefficients

$$\begin{vmatrix} 0 & a_1 & a_2 & a_3 & a_4 & a_5 \\ a_1 & a_2 & a_3 & a_4 & a_5 & 0 \\ 0 & 0 & 0 & b_1 & b_2 & b_3 \\ 0 & 0 & b_1 & b_2 & b_3 & 0 \\ 0 & b_1 & b_2 & b_3 & 0 & 0 \\ b_1 & b_2 & b_3 & 0 & 0 & 0 \end{vmatrix} = 0.$$

In certain cases an analogous method may be applied to systems of three or more equations. A method of similar application to that of Sylvester had been discovered previously by Euler. (See ALGEBRA, ELEMENTARY; DETERMINANTS). Consult Burnside and Ponton, 'Theory of Equations' (Dublin 1901); Dickson, 'Introduction to the Theory of Algebraic Equations' (New York 1903); Muir, 'Theory of Determinants' (London 1890); Young, 'Monographs on Modern Mathematics' (New York 1911).

**ELIOT, Charles William**, American college president and educator: b. Boston, Mass., 20 March 1834. He was graduated from Harvard in 1853, was tutor in mathematics there 1854-58, and assistant professor of mathematics and chemistry in the Lawrence Scientific School, Harvard, 1858-63. After spending two years in Europe studying chemistry and investigating educational methods he was professor of analytical chemistry in the Massachusetts Institute of Technology 1865-69. In the last-named year he became president of Harvard University, which position he resigned in 1909. He is one of the foremost writers and speakers of the day upon educational and social problems and has exerted a strong influence upon the trend of American thought. During his incumbency Harvard College introduced what is commonly known as the elective system—a system since adopted by most American colleges, whereby students no longer must pursue a rigidly prescribed curriculum, but may choose (within certain groups) any of the subjects taught. Under President Eliot, too, Harvard's college course could be covered in three years instead of four, thus making it possible to complete both the college and a professional course in six, instead of seven, years. Numerous other educational reforms were advocated by Dr.

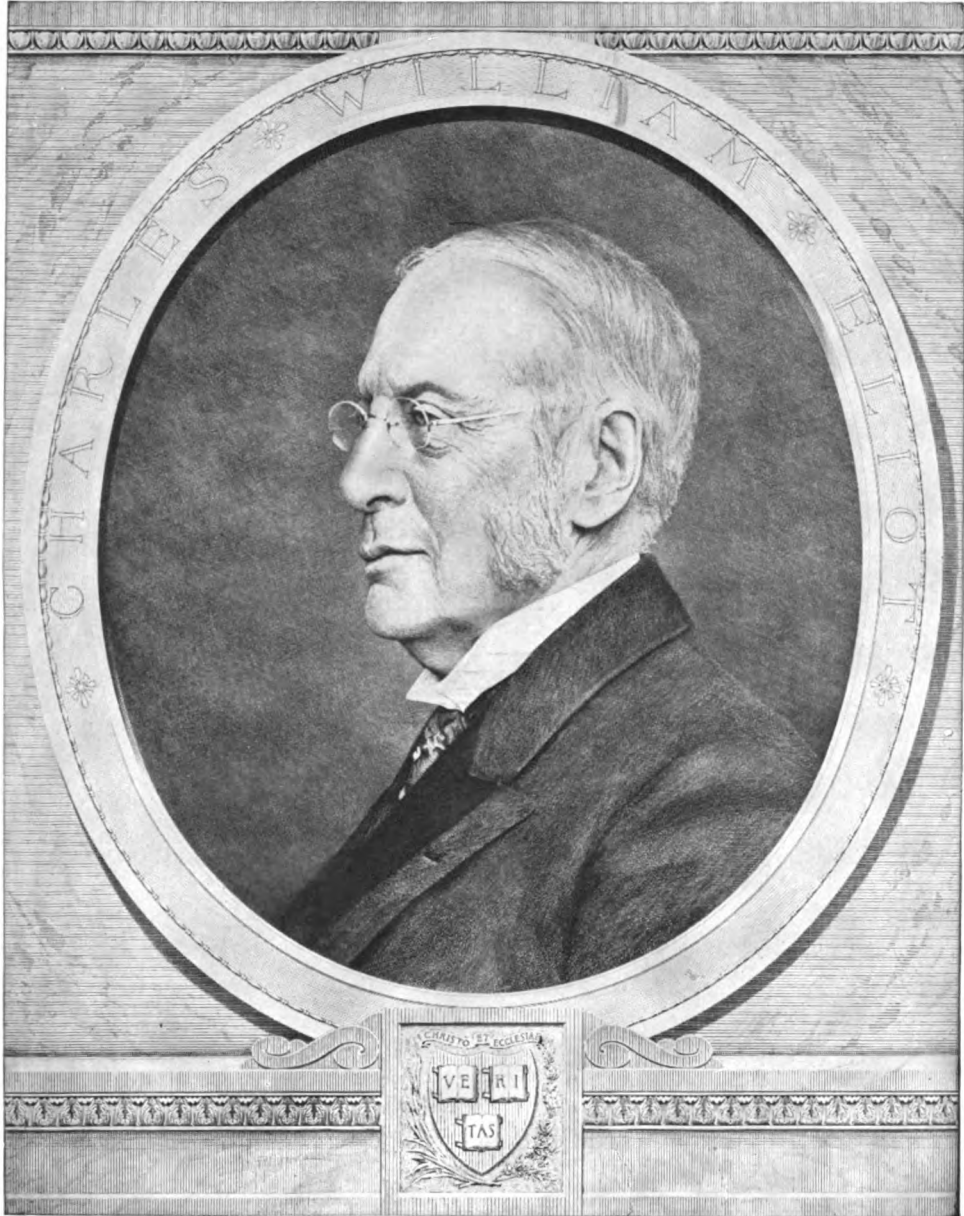

From the etching made by John A. Lowell & Co., Boston. Copyright, 1904

**CHARLES WILLIAM ELIOT**



Eliot in his long career at Harvard, which have placed him among the greatest American educators and have won great prestige for the university over which he presided. He has published 'Manual of Qualitative Chemical Analysis' (with F. H. Storer); 'Manual of Inorganic Chemistry' (with F. H. Storer); 'Five American Contributions to Civilization and Other Essays'; 'Educational Reform'; 'More Money for the Public Schools' (1903); 'John Gilley' (1904); 'The Happy Life' (1905); 'The Road Towards Peace' (1915).

**ELIOT, George** (the pseudonym of **MARY ANN** or **MARIAN EVANS CROSS**), the most distinguished of English women novelists: b. Arbury farm, near Nuneaton, Warwickshire, 22 Nov. 1819; d. Chelsea, 22 Dec. 1880. Her father, Robert Evans, who was of Welsh extraction, was agent on the estates of Francis Newdegate; and the future novelist was the second daughter and third child of his second marriage. When Marion was a few months old, the family removed to Griff, a "cheerful red-brick, ivy-covered house," and there the first 21 years of her life were spent amid scenes and among a people that she was destined to immortalize. Her first school was at Attleborough, and from there she went to a boarding school at Nuneaton, one of the governesses at which, Miss Lewis, became a warm friend, and succeeded in awakening religious impressions that were deepened in the years she spent between the ages of 13 and 16, at Miss Franklin's school in Coventry. The death of her mother, to whom she was tenderly devoted, which occurred in 1836, was succeeded soon after by the marriage of her sister, and the care of her father's home then devolved upon her. The duties of the household were accompanied by lessons in Italian and German, Greek and Latin; she was already an omnivorous reader and one with a fine power of selection; she was passionately fond of music, and an excellent player on the piano on which instrument she might have attained some distinction as an executant but for the "agonies of shyness" with which she was afflicted. Her father's retirement from active life was followed by her brother's appointment to succeed him, and Marian and her father removed in 1841 to Toleshill Road, Coventry.

Up to this time Marian was deeply imbued with evangelical religion, which had been stamped upon a mind of singular receptivity by the example and instruction of her teachers. Then with expanding intellect came vanishing faith. Among the new friends was Charles Bray, whose wife was a sister of Charles Hennell, the author of a work entitled 'An Inquiry Concerning the Origin of Christianity,' published in 1838, and rationalistic in tone. The reading of this and similar works effected a complete revolution in the inner life of Marian Evans; she abandoned the creed of her girlhood, and determined in the spring of 1842 not to go to church. This was the occasion of a temporary breach with her father, who was a churchman of the old school and little disposed to brook rebellion in his own household. After a short absence from home and through the efforts of friends a reconciliation was effected; Marian returned and resumed her attendance at church, and although she never retraced by a step the course she had taken, her works are witness to the insight and tenderness, born of

understanding, with which she approached evangelical beliefs.

The years from 1842 to 1849 were devoted to attendance on her father during his recurrent illnesses, and by the translation of Strauss's 'Life of Jesus,' a work which entailed two years of exacting labor and was published anonymously in 1846, and for which she received the sum of £20. The completion of this work left her "Strauss-sick—it makes her ill dissecting the beautiful story of the Crucifixion." After the death of her father (1849) she went to the Continent and passed about eight months in Geneva. On her return she took up work on the *Westminster Review*, acting as sub-editor, and in 1853 went to reside at the office of the magazine at 142 Strand. In the same year she published a translation of Feuerbach's 'Essence of Christianity,' the only work published under her own name, and the leading idea in which is that man has made God in his own image—the spiritualized form of his hopes and desires. At this period she made the acquaintance of Froude, J. S. Mill, Carlyle, Harriet Martineau, Herbert Spencer and George Henry Lewes (q.v.).

With Lewes, whom she describes as "a man of heart and conscience, wearing a mask of flippancy," she entered into a connection which she regarded as a marriage without the sanction of law. He had a wife already, from whom he was separated under circumstances that precluded the possibility of divorce. This alliance is regarded by many as the one fatal step in her life, and to it they attribute the somewhat obtrusive self-consciousness that is apparent in some parts of her writings, and note that the novelist's own conduct does not square with her teachings. There is no doubt however that they lived happily together, and that their union exercised a profound mutual influence on their literary life and fortunes. Lewes undertook all business matters for her, acted as critic and mentor; and tactfully shielded her from the perusal of unfavorable or inept reviews. Indeed but for the constant encouragement and stimulus given by Lewes, the chances are that Marian Evans would never have discovered herself as a creative artist, for although possessing singular robustness and health of intellect she was of low physical vitality, subject to acute fits of depression, and only by strong effort was able to undertake creative work. Lewes and Marian Evans left England in July 1854 and wintered in Germany. On their return she labored at a translation of Spinoza's 'Ethics' and wrote reviews for the *Leader*. An article contributed to the *Westminster Review* entitled "Evangelical Teaching: Dr. Cumming," in which the famous preacher of Crown Court was subjected to a criticism that was at once informed, witty, pointed and scathing, revealed to Lewes that he had mated with genius, and under his encouragement, 'The Sad Fortunes of the Reverend Amos Barton' was begun in September 1856, and appeared in *Blackwood's Magazine* in January 1857. This was followed by 'Mr. Gilfil's Love Story,' and 'Janet's Repentance,' the three stories being published in book form in 1858, under the pen name of 'George Eliot.' Discerning critics like Thackeray and Dickens recognized that a new force had arisen in England fiction, and the latter divined that the creator was a woman.

It may be questioned if the author ever bettered those faithful sketches of old-fashioned life in the Warwickshire of her girlhood, with their genial and kindly humor, warmth of sympathy, power of description and moving but unforced pathos. 'Scenes of Clerical Life' could not be called a popular success, but with her next novel 'Adam Bede' (1859) written partly in England, partly at Munich and Dresden, the reading public was taken by storm, and it has remained the most popular of George Eliot's works. The genesis of the story came to the author through an aunt, a Methodist preacher, who had occasion to pass a night with a girl condemned for child murder, the aunt and girl respectively becoming the Dinah Morris and Hetty Sorrel of the novel. George Eliot was put to considerable annoyance by the claims made to its authorship, especially by one Liggins in her native county, and only the intervention of Blackwood the publisher set the matter at rest. It then became known that Marian Evans, the *Westminster* reviewer, and George Eliot were identical. 'The Mill on the Floss' (1860) is to some extent autobiographical, the charming portraits of Maggie and Tom Tulliver being drawn from her own and her brother Isaac's childhood. 'Silas Marner,' which many regard as her most perfect story, followed in 1861. In 1860 George Eliot had spent the summer in Italy collecting material for her great historical romance, 'Romola,' first published serially in *Cornhill*, for which she received the then unheard-of sum of £7,000, and which appeared in book form in 1863. In order to write this she went through a course of reading that would have qualified her to write a history. Her husband says that, "it ploughed into her more than any of her works," and she herself says she "began it a young woman, and finished it an old woman." Although it must be pronounced a masterpiece, reflecting her powers at their very highest, it cannot be regarded—in spite of the fine character drawing in it, especially of Tito Milema and Tessa—as a faithful and lifelike reproduction of the Florence of the Renaissance. The appearance of 'Felix Holt the Radical' in 1866 seemed to betoken diminishing powers. She then essayed poetry, 'The Spanish Gypsy' appearing in 1868, and 'Agatha' in 1869; and these revealed that her art did not lie in that direction. The only poem of hers that is certain to live is the noble piece beginning 'O may I join the choir invisible.' 'Middlemarch' (1871-72), a novel which may be regarded as inspired by her life at Coventry, as her early works drew their stimulus from childhood and girlhood, is notable for some fine characterizations of middle and upper class life in an English provincial town, and is replete with pregnant thought. 'The Legend of Jubal and Other Poems' appeared in 1874. 'Daniel Deronda,' her last great work, was published in book form, and in the opinion of at least one noted critic is the best of her novels and marks the culminating point in her career. On 28 Nov. 1878, Lewes died. This bereavement was a crushing blow to George Eliot; for weeks she saw no one and wrote no letters; and she busied herself preparing his unpublished work for the press, and founded a scholarship in his memory for scientific investigation. 'Theophrastus Such,' written sometime earlier, appeared in 1879. She never really got over the

shock of Lewes's death. In the months of sorrow and depression following on that event she had been lifted somewhat by the forethoughtfulness and helpful sympathy of J. W. Cross, an American—an old friend of her own and of Lewes—to whom she was married on 6 May 1880. But their married life was cut short, for, after contracting a chill at a concert, she died on 22 December of the same year. The first collected edition of her novels appeared 1878-80, and a 25-volume edition was issued at Boston in 1908. See ADAM BEDE; MIDDLEMARCH; MILL ON THE FLOSS, THE; ROMOLA; SILAS MARNER.

**Bibliography.**—Consult her 'Life and Letters,' by J. W. Cross (3 vols., London 1885); biographies by Blind (London 1883); Browning, O., (London 1892); and Stephen, L. (New York 1902); Deakin, 'Early Life of George Eliot' (Manchester 1913); Dowden, E., 'Studies in Literature' (London 1878); Hutton, 'Modern Guides of English Thought' (London 1887); James, 'Partial Portraits' (1888); Mottram, 'The True Story of George Eliot in Relation to Adam Bede' (New York 1905); Myers, 'Essays Modern' (1883); Parkinson, 'Scenes from the George Eliot Country' (Leeds 1888).

**ELIOT, SIR JOHN**, English orator and statesman: b. Port Eliot, Cornwall, 20 April 1592; d. London, 27 Nov. 1632. He studied at Exeter, but did not take a degree. He then took up law, and traveled in Europe, where he became an intimate friend of George Villiers, later Duke of Buckingham. In 1614 he was sent to the "Addled" Parliament for Saint Germans. In 1618 he was knighted and in the following year, through the patronage of the Marquis of Buckingham, was made vice-admiral of Devon. In this capacity he was energetic in suppressing piracy. His arrest of a notorious pirate named Nutt brought him into collision with Nutt's protector, Sir George Calvert, then Secretary of State; and Eliot was imprisoned on trumped-up charges for three months. The return of the Duke of Buckingham accomplished his release. He was returned to Parliament in 1624, where his remarkable independence and fluent oratory at once brought him into prominence. He supported the proposed war with Spain and began his life-long opposition to encroachments on the rights of the House of Commons, which he considered the backbone of the national government. He was re-elected in 1625, during which session he opposed the leniency toward Catholicism and became an ardent supporter of constitutional rights. In 1626, the accumulated mismanagements and instances of the selfish policies of Buckingham completely undermined Eliot's faith in him and an impeachment followed. This, together with Eliot's opposition of forced loans, led to his imprisonment. At the protest of the Commons he was shortly released and returned to Parliament in 1628. He joined Coke in promoting the Petition of Right which was signed by Charles on 7 June. In 1629, after the murder of Buckingham, Eliot devoted himself to the earnest support of Protestantism. His attempts to resist the king's tonnage and poundage taxes were met by the monarch with contempt and with the adjournment of Parliament. When this last measure was to be carried out a second time, Eliot insisted that the





From the etching by Hajon

**GEORGE ELIOT**



speaker be held in his chair while a speech was read indicating the king's encroachments on constitutional rights. When summoned to trial he declared that he was answerable to Parliament alone for his actions and would not reply to charges brought against him by any other body. He was confined in the Tower, and finally tried with Holles and Valentine for conspiracy against lawful order. Eliot refused to yield an inch in submission to the king and was fined and imprisoned in 1629, where he sickened and died. During his imprisonment he wrote a work on constitutional monarchy entitled the 'Monarchy of Man,' and also an account of the first Parliament of Charles I under the title 'Negotium Posteriorum'; 'An Apology for Socrates,' a vindication for his own public conduct, and 'De Jure Majestatis,' a treatise on government. Eliot was not republican in his views, but believed rather that the ideal state was a constitutional monarchy in which the powers of the king would be strengthened and interpreted by Parliament. He was distinguished by the enthusiasm rather than the logical depth of his speeches. The king's treatment of Eliot was one of the causes of the unpopularity of that monarch which led to his downfall. Pym did much to systematize the political theories of Eliot. Consult Forster, 'Life of Sir John Eliot' (London 1871); and Gardiner, 'History of England' (London 1893-95).

**ELIOT, John**, American colonial missionary, "the Indian Apostle": b. probably at Widdford, Hertfordshire, 1604; d. Roxbury, Mass., 20 May 1690. He was graduated at Cambridge in 1622, and, after taking orders in the Church of England, quitted his native country for conscience's sake and landed at Boston, New England, in 1631. In 1646, after two years study of the Indian language, he delivered a long sermon in the native dialect at Nonantum, and other meetings soon followed. He shortly after began to establish his converts in regular settlements, his work meeting with approval both in the colony and at home; in England a corporation was founded in 1649 "for the promotion and propagating the Gospel among the Indians of New England," which defrayed the expenses of the preachers and the cost of printing translations. At one time there were over a dozen townships of "praying Indians" within the bounds of Massachusetts, and many more outside these limits, with numbers estimated in 1674 at 3,600; but, although the organization survived until the death of the last native pastor in 1716, the decay of the "praying towns" was rapid after the war with King Philip (1675), in which the converts suffered equal cruelties at the hands of their countrymen and of the English. There are monuments to Eliot's memory in the Indian burying-ground at South Natick, and at Newton, near the scene of his first Indian sermon. A man of earnest piety and devotion, warm-hearted and of a singularly attractive manner, he has left a memory that is honored among the first in the history of New England. With Thomas Weld and Richard Mather, Eliot prepared an English metrical version of the Psalms, the 'Bay Psalm-book' (Cambridge 1640), as the first book printed in New England. He was also the author, among other works, of 'The Christian Commonwealth'

(London 1659), suppressed by the court and now extremely rare; 'The Communion of Churches' (1665), the first book privately printed in America; and of translations into the Indian tongue of Baxter's 'Call'; Bayly's 'Practice of Piety' (abridged); and Shepard's 'Sincere Convert.' But the great work of his life was the translation of the Bible into the tongue of the Indians of Massachusetts (Algonquin), of which the New Testament appeared in 1661, and the whole work, with a version of the Psalms in metre and a page of "catechism" in 1663. The longest single word in it is "Wutappesittukqussunnoohwehtunkquoh," signifying "kneeling down to him," in Mark i, 40; which illustrates the jest of Cotton Mather, who said he thought the words of the language must have been growing ever since the dispersion at Babel. Only 14 complete copies of the first and second editions are known to be in existence. A scientific study of Eliot's Indian Bible was made by J. H. Trumbull (q.v.), and his manuscript published 1903 as 'Bulletin 25' by the Bureau of American Ethnology, Washington. Its title is the 'Natick Dictionary' and it is divided into two parts, the first giving the Natick words with English definitions and the second giving the English words with Natick definitions. While it is devoted to the Natick language it is practically a dictionary of all the Algonquin languages of Massachusetts, for the tribes of that part of the country spoke practically the same language, though each had its dialectic variations. Eliot's 'Indian Grammar Begun' was printed in 1666; his 'Indian Primer' in 1669. The finest collection of unique and scarce copies of Eliot's works is in the Lenox Library, New York; many of them have been reprinted. The best 'Life of Eliot' is that by Francis (Vol. V); Sparks' 'American Biography' 1st series (1836); the earliest that by Cotton Mather (1691). Consult also articles in the 'Cyclopædia of American Biography' (Vol. II, 1887); and the 'Dictionary of National Biography' (Vol. XVII, 1889).

**ELIOT, Sir John**, English colonial clergyman: b. 7 Nov. 1685; d. 22 April 1763. He was a grandson of John Eliot, the "Apostle to the Indians," and was long a pastor at Killingworth, Conn. He was an able preacher, a botanist and a scientific and practical agriculturist; was the first to introduce the white mulberry tree into Connecticut, and discovered a process of extracting iron from ferruginous sands. He was also regarded as the first physician of his day in the colony; and such was his success in the treatment of insanity and chronic complaints, that he was sometimes sent for to Newport and Boston, and was more extensively consulted than any other physician in New England.

**ELIOT, Samuel**, American educator and historian: b. Boston, Mass., 22 Dec. 1821; d. Beverly, Mass., 14 Sept. 1898. He filled the chair of history and political science in Trinity College, Hartford, Conn. (1856-64); was its president (1860-64); and lecturer on history at Harvard (1870-73), and head master of the Girls' High School in Boston (1873-76). From 1876-80 he served as superintendent of the Boston public schools. Among his publications are 'The History of Liberty' (1853); 'The

Liberty of Rome' (1849); 'Life and Times of Savonarola' (1856); 'Manual of United States History Between the Years 1492 and 1850' (revised ed., 1873); and 'Stories from the Arabian Nights' (1879); 'Selections from American Authors' (1879).

**ELIOT, Samuel Atkins**, American Unitarian minister: b. Cambridge, Mass., 24 Aug. 1862, son of Charles W. Eliot (q.v.). He was graduated at Harvard College 1884; was pastor of Unity Church, Denver, 1889-93, and of the church of the Saviour, Brooklyn, 1893-98. He was secretary of the American Unitarian Association 1898-1900, becoming its president at the latter date. He is a member of the United States Board of Indian Commissioners; the president of the trustees of the Hackley School, an editor of the *Hibbert Journal*; vice-president of the Massachusetts Federation of Churches, etc. He holds the honorary degree of D.D. from Bowdoin and LL.D. from Western Reserve University.

**ELIS**, ἔλις, (1) a country in the west of Peloponnesus, where Olympia was situated. It was bounded on the east by Arcadia, on the south by Messenia and ran along the coast, watered by the river Alpheus. There were three districts in their country—Colle, or Hollow Elis, Pisatis and Triphylia; the two latter being subject districts. It was the seat of the greatest national festivals. The Athenians were the first to raid the coast during the Peloponnesian War and frequent conquests followed. After the suppression of the games at Elis by the Emperor Theodosius in 394 A.D., the Eleans lost their prestige entirely. Elis and Archaia now form a nomarchy of Greece with the capital at Pyrgos. (2) Elis, once the capital of Elis, is now called Kaloskopi. (See OLYMPIA). Consult Curtius, 'History of Greece.'

**ELISHA**, a member of the tribe of Issachar, a citizen of Abel-meholah, was a disciple of Elijah, and his successor in the prophetic office. His prophetic ministry, which was exercised, as was that of Elijah, in northern Israel, began in the reign of Ahab, and continued through the reigns of Jehoram, Jehu, Jehoahaz, and during a part of the reign of Joash, thus covering a period of more than half a century. He was a man of very different character and mode of life from Elijah, although master and disciple seem to have been most warmly attached to each other. Elijah was a son of the desert; Elisha came from a quiet farm in the Jordan Valley. Elijah lived apart from men; Elisha, for the most part, dwelt in the city, either at Jericho among the sons of the prophets, or in his own home at Dothan or Samaria. Elijah had nothing to do with kings except to rebuke them; Elisha was their friend and counsellor. Yet it is easy to make too much account of their difference of character and life and to suppose that it affected essentially the prophetic aim and religious attitude, so that these were quite different in the case of each prophet. But to claim that the work and spirit of Elisha were in marked contrast to those of Elijah would be to claim too much. The declaration of Jehovah to Elijah on Mount Horeb, "Him that escapeth from the sword of Jehu, shall Elisha slay" (1 Kings xix, 17), shows that it was Elijah's work of vengeance and, destruction which

Elisha was to continue. It was Elisha, moreover, who devised the plan for the destruction of the house of Ahab (2 Kings ix, 1-3). It was Elisha, also, who reproved King Joash for his lack of zeal for the utter overthrow of Syria (2 Kings xiii, 19). It is to be remembered in this connection that the accounts which we have concerning the career of Elisha, whatever the cause may be, relate rather to his deeds as a man, than to his work as a prophet.

For some six or seven years after his call to the office of prophet by Elijah at Abel-meholah (1 Kings xix, 19-21), he was a helper and disciple of Elijah. But we do not know just where he was in all this time, or the exact nature of his work. At the close of this time, after the ascension of Elijah, he began his own independent work as a prophet (2 Kings ii, 13-22). The character of the narrative in the Second Book of Kings makes it impossible to arrange the events of his life in chronological order. It is better, therefore, to group them under two headings: (a) his deeds in private life; (b) his deeds in public life.

Under the first class, we may put (1) the healing of the waters of Jericho (2 Kings ii, 19-22); (2) the punishment of the lads of Bethel (2 Kings ii, 23-25); (3) the saving of a widow's son from slavery (2 Kings iv, 1-7); (4) the restoring of the Shunammite's son to life (2 Kings iv, 32-36); (5) the rendering of some poisonous pottage harmless (2 Kings iv, 38-41); (6) the miraculous feeding of a hundred men (2 Kings iv, 42-44); (7) the healing of Naaman the leper (2 Kings v); (8) the causing of the iron head of an axe to swim (2 Kings vi, 1-7).

Under the second class we may put (1) his helpful work in the campaign against Moab (2 Kings iii, 11-24); (2) his bringing of the Syrian army into Samaria, where they were made prisoners (2 Kings vi, 8-23); (3) his activity in the siege of Samaria (2 Kings vi, 24, vii, 2); (4) his visit to Damascus to announce to Hazael that he shall be king of Syria (2 Kings viii 7-13); (5) the sending of a messenger to anoint Jehu to be king of Israel (2 Kings ix, 1-3); (6) the assuring of King Joash that Israel should be victorious over Syria (2 Kings xiii, 14-19).

But the power of Elisha for good did not end with his life. Of him alone of all the prophets it is recorded that he wrought a miracle after his death. A dead man who was hastily cast into the sepulchre of the prophet, on touching the prophet's bones, came to life, and stood upon his feet (2 Kings xiii, 20-21). Consult Grove, 'Elisha' (in Smith's 'Dictionary of the Bible,' 1868); Strachan, 'Elisha' (in Hastings' 'Dictionary of the Bible,' 1899); Farrar, 'Second Book of Kings' (Chaps. iii-xvii in the 'Expositor's Bible,' 1902).

SYLVESTER BURNHAM,  
Professor of Old Testament Interpretation,  
Theological Seminary of Colgate University.

**ELIXIRS**, in pharmacy, are aromatic, sweetish, spirituous preparations, containing small quantities of active medicinal drugs. They are now mostly used as vehicles for other remedies and have very little potent action save that of the alcohol which they contain. Elixir aromaticum and Elixir glycyrrhizæ (licorice) are the only two elixirs recognized by the 1917 revision of the United States Pharmacopœia.

**ELIZABETH**, the wife of the priest Zacharias and mother of John the Baptist, and a relative of Mary, the mother of Jesus. An angel foretold to her husband the birth of a son in her old age; and it was also foretold by the angel Gabriel to the Virgin Mary, as an assurance of the birth of the Messiah.

**ELIZABETH**, queen of England: b. Greenwich, 7 Sept. 1533; d. Richmond, Surrey, 24 March 1603. She was the daughter of Henry VIII and of Anne Boleyn. After her mother had been beheaded (1536) both she and her sister Mary were declared bastards, but finally she was placed after Prince Edward and the Lady Mary in the order of succession. Thus, while the first two marriages of King Henry were both still held to be illegal, the children of both were legitimized. Elizabeth received a classical education, as was customary with women of rank in her time, and under her tutor, Roger Ascham, is said to have attained very considerable proficiency in Latin and Greek. During her father's life, as well as in the reign of her brother, various negotiations were entered into for her marriage. The duke of Angoulême and Philip of Spain, who afterward married her sister, were among the matches proposed for her, but the only affair of this kind in which she may be supposed to have been personally interested was the suit of Lord Seymour of Dudley, the Protector Somerset's brother. It is certain that even during the life of Catharine Parr, the widow of Henry VIII, whom he married, his attentions to the Lady Elizabeth were only too well encouraged. Both before this marriage and after the death of his wife he was a suitor for the hand of the princess; but his ambitious designs in this and other matters were not countenanced by the council, and ultimately cost him his life.

On the death of King Edward, Elizabeth vigorously supported the title of Queen Mary against the pretensions of Lady Jane Grey, by which her own title as well as her sister's were barred. She rode to meet her sister, accompanied by 1,000 horse, and this bold proceeding was of no small service in confirming the doubtful in their allegiance; but Elizabeth gained little for herself by a policy in which it was well understood she had her own interest in view. After Wyatt's conspiracy her life was in great danger, and was probably saved only by the intercession of Philip. She was committed to the Tower, from whence she was removed to Woodstock, where she was confined with great strictness. She afterward, through Philip's intercession, obtained greater liberty; but throughout the whole reign continued an object of suspicion and surveillance. The danger she now incurred developed traits in her character which ever after continued conspicuous, her prudent self-control and power of dissimulation. She made every demonstration not only of conformity, but of zealous adherence to the established religion. Her conduct in this must not be judged from the point of view of rigid Protestantism, which Elizabeth never professed; but there were some at least among the Roman Catholic ceremonies and customs to which she could not be supposed to give a sincere adherence. Nevertheless, her simulated zeal must have been well and ably sustained, for her conduct was not left to the report of friends, but carefully

watched by spies and informers. Philip was most anxious to have her married out of the kingdom; and if the Duke of Savoy, whom he proposed, was unacceptable from his Roman Catholicism, there was Eric, son of the king of Sweden, who long after continued to press his suit; but Elizabeth refused both. She felt in herself a capacity for rule, and her sister's ill health opened up for her an early prospect of the throne, which she was unwilling to peril. Mary's reign was not without advantage to Elizabeth. It tried her councillors as well as herself, and gave her the opportunity of selecting them to advantage. Her adviser throughout the whole of it was William Cecil, afterward Lord Burleigh, who had already been a minister under Edward VI, and continued for the rest of his life to be one of the chief councillors and ablest ministers of Elizabeth, to whom he was in many respects a congenial spirit.

On 17 Nov. 1558 Mary's disastrous reign came to a close, and Elizabeth was immediately recognized queen by Parliament. On entering London she was met by the bishops, whom she permitted to kiss her hand, with the exception of Bonner, "whom she omitted for sundry severities in the time of his authority." It was now that the caution and secrecy characteristic equally of Elizabeth and Cecil, and which enabled them to do such great things, appeared in spontaneous exercise. The Roman Catholic religion was still predominant in the House of Lords, and any attempt to overthrow it suddenly might have been attended with the greatest danger. Elizabeth made no immediate change in her habits. For a full month the ceremonies of the Roman Catholic Church were retained in all their state. A solemn funeral service was held for Queen Mary in Westminster Abbey, at her interment on 13 December. The Queen even intimated her accession to the Pope. She retained the greater part of her sister's council, choosing only seven new councillors, who were Protestants, it is true, but not then known as such. Like Cecil and herself, they had all conformed, and possessed the necessary qualification for Elizabethan councillors of accomplished dissimulation. Such were her difficulties, notwithstanding her great prudence, that at her coronation only one of all the bishops, Oglethorpe of Carlisle, could be found to set the crown on her head. The obstacle lay in the terms of the oath of allegiance, which affirmed that the sovereign was the supreme head of the Church, and to which no loyal Catholic could subscribe. She had also before this authorized the reading of the liturgy in English. The first great object of her reign was the settlement of religion. A Parliament was immediately called, to which this work was assigned. It met on 25 January, and was dissolved 8 May, but its object was already accomplished. The nation was prepared for a return to the reformed faith or rather to the *via media* which is embodied in the Anglican Church—and Parliament was at the bidding of the court. The reformation of religion in England was the work of Cranmer, and had already been accomplished in the reign of Edward VI; the re-establishment of the ecclesiastical system of the national Church on the basis on which it has remained to the present day was the work of Cecil and Elizabeth, and it was nearly completed in this Parliament. Elizabeth had less extreme opinions than many sup-

porters of the new faith. She was tolerant, for instance, in regard to images and was fond of ceremonial and is said to have entertained scruples as to the extent of the royal supremacy in spiritual matters; but if she did, they must have been purely speculative. They certainly vanished on the first taste of power.

If the formal establishment of the reformed religion was easily completed, the security and defense of the settlement was the main object of the policy and the chief source of all the struggles and contentions of her reign. What made the position so difficult was the intolerance by which at this period and for long after all religious sects were characterized. No sooner were the Puritans freed from the restrictive measures of Mary's reign than they began to claim predominance for their own dogmas. But it was far from the intention of the Queen and the supporters of the Established Church, notwithstanding the common persecutions they had endured, to grant them even liberty of worship. Elizabeth's own determination, as expressed by herself, was that none should be allowed to turn aside either to the right hand or the left from the drawn line of prescribed duty, and in insisting upon uniformity of worship she was not singular, but was acting in the spirit of her age. This principle was not less firmly held in her reign than in her sister's; and Roman Catholics on the one hand, and Puritans on the other, restrained only by their dread and hatred of each other, were made the irreconcilable enemies of the existing order. Moreover, from the necessities of the struggle the severities of Elizabeth's reign went on increasing as time advanced. At first no one suffered death for his opinions; but eventually many were executed for this cause. The struggle against Roman Catholics was the most severe, chiefly because they were supported by foreign powers; so that while their religion was wholly prohibited, even exile was forbidden them in order to prevent their intrigues abroad. Simple non-conformity, from whatever cause, was pursued with the severest penalties. The fine imposed for non-attendance at church was £20 per month, while so straight were the lines of conformity drawn, that many more clergymen were driven out of the Church by differences about the position of altars, the wearing of caps and such like matters, than were forced to resign by the change from Rome to Reformation. These stringent measures were, however, the rigid consequences of the false position assumed.

Elizabeth's first Parliament approached her on a subject which, next to religion, was the chief trouble of her reign, the succession to the crown; they requested her to marry. She replied in a long speech, declaring her intention to live and die a virgin. It is certain, from her conduct both before and after, that this declaration was only a convenient affectation of prudery, which at once served to flatter her vanity and to veil her real indecision. She saw too clearly for her own interest the restraints to which each particular marriage might subject her and therefore she shunned them all, thus leaving open the question of the succession.

On Elizabeth's accession the country was at war with France. Peace was easily concluded 1559; but the assumption by Francis and Mary of the royal arms and titles of England led to an immediate interference on the part of Eliza-

beth in the affairs of Scotland. She entered into a league with the Lords of the Congregation, or leaders of the Reformed party; and throughout her reign this party became distinctively an English one, and was frequently serviceable in furthering her policy. She also gave early but half-hearted and dubious support to the Huguenot party in France, and to the Protestants in the Netherlands. Though she disliked war as an occasion of expense and had no toleration for any kind of nonconformity, throughout Europe she was looked on as the head of the Protestant party. She roused the implacable resentment of Philip, who strove in turn to excite the Roman Catholics against her, both in her own dominions and in Scotland. After the detention of Mary queen of Scots in England, he fomented the various rebellions in her favor, formed in England and Ireland and at her death declared himself her avenger. Mary, as is well known, was imprisoned 19 years in England, whither she fled to the protection of Elizabeth. Her imprisonment was followed by a series of conspiracies, beginning with that under the earls of Northumberland and Westmoreland and ending with the plot of Babington, which finally determined Elizabeth to proceed to extremities with her captive. The execution of Queen Mary was, nevertheless, the chief political blunder of Elizabeth's reign. If the death of Mary did not raise up new enemies to Elizabeth on the Continent it at least gave a just cause of offense to those she already had. Elizabeth had for some time been engaged in a negotiation for marriage with the Duke of Alençon (afterward of Anjou); and in 1580 the Duke arrived in London to pursue his suit, which had lasted nearly 12 years, in person. He was well received, but still the Queen hesitated. She was now 47. The following winter the Duke paid another visit and the marriage was all but concluded, but she finally informed him she could never marry.

The state of France, as indicated by the change of government consequent on the accession of Henry IV, who was assisted by Elizabeth, obviated any danger that might have arisen from the indignation which the execution of Queen Mary had caused in that country. Nowhere, however, was that event more meekly borne than by King James. The Scottish Solomon had thought his mother's danger a favorable opportunity for sententious observations about the strangeness of her case, and now his philosophy was nonplussed. His awe of Elizabeth and his dread of interfering with his own right of succession to England made him powerless, and he accepted an addition to his pension in full of his grievances. Philip was not to be so appeased. He had other grievances, to which the execution of Mary lent edge. The fleets of Elizabeth had galled him in the West Indies, her arms and subsidies had helped to deprive him of the Netherlands; the Armada was already in preparation. Therefore he called the Queen of England a murderer, and refused to be satisfied even with the sacrifice she seemed prepared to make of her Dutch allies. The Armada sailed on 2 May 1588. Its fate is too well known to need recapitulation. The war with Spain dragged on till the close of Elizabeth's reign.

During her long rule Elizabeth showed her judgment in nothing so much as in the counsellors she trusted. But while the splendor of

her government at home and abroad was sustained by such men as Burleigh, Bacon, Walsingham, Throgmorton and Davison, who served her with a zeal which did not always spare even their own reputations, she had personal favorites of less merit who were often more brilliantly rewarded. It is sufficient to name Dudley, whom she created Earl of Leicester; and Essex, who was still more a personal favorite, though much less a courtier. The latter had some merit as a soldier; but his violent temper, ill-suited to the Queen's haughty disposition, brought about his ruin. He was beheaded in 1601 and Elizabeth never forgave herself his death. Her own health soon after gave way, and she died, naming James of Scotland as her successor.

Besides its political glories, won in despite of the Queen's somewhat insular and narrow outlook, the reign of Elizabeth was the golden age of English literature. If all else could be forgotten, it would be remembered as the age of Spenser and of Shakespeare, not to mention a host of minor names. The naval achievements of Drake and the discoveries of Raleigh concurred to do it honor. Thus everything conspired to throw a halo round the name of Elizabeth, when regarded as a sovereign, and seen as she would be in her own day, especially by foreign beholders, through the drapery of state. If a minute criticism has exposed some of the weaknesses of the individual woman who bore this burden, it must be remembered that the process is only half fair. As a sovereign she is entitled to her surroundings, and as an absolute ruler, as to a great extent she undoubtedly was, she must have her share of praise for the good that was done in her name. It is no small merit to select good councillors and to adhere to them. Elizabeth knew how to do both; and yet she was no puppet in the hands of her advisers. Though haughty and imperious to the Commons, she knew both when and how to yield. She studied with rare sagacity the temper of the people; and high as were her notions of prerogative, she may fairly be considered the first constitutional monarch of England.

**Bibliography.**—Cambden, 'History of Queen Elizabeth' (1622); D'Ewes, 'Journals of all the Parliaments of the Reign of Queen Elizabeth' (1682); Bruce (ed.), 'Letters of Elizabeth and James VI' (1849); Wright, 'Queen Elizabeth and Her Times' (1838); Strickland, 'Lives of the Queens of England'; Wiesener, 'La jeunesse d'Elisabeth d'Angleterre' (1878); Froude, 'History of England' (Vols. VII-XII, 1870); Hume, Martin, 'Calendar of Spanish State Papers: Elizabeth'; *ibid.*, 'Courtships of Queen Elizabeth' (1896); *ibid.*, 'The Year After the Armada' (1896); *ibid.*, 'The Great Lord Burghley' (1898); Creighton, 'Queen Elizabeth' (1899); Beezley, 'Queen Elizabeth' (1902); Jessop, 'Queen Elizabeth,' in 'Dictionary of National Biography.'

**ELIZABETH**, empress of Austria: b. Possenhofen, Bavaria, 24 Dec. 1837; d. Geneva, 10 Sept. 1898. She was the daughter of Duke Maximilian Josef of Bavaria, and married her cousin, the Emperor Franz Josef, on 24 April 1854. Together they were crowned with the insignia of Saint Stephen when the inauguration of the dual system was solemnized. She

was greatly admired by Austrians and Hungarians alike. While visiting Geneva, Switzerland, she was assassinated by an Italian anarchist. Consult Friedmann, 'Kaiserin Elizabeth' (Berlin 1898).

**ELIZABETH, Madame** (ELISABETH PHILIPPINE MARIE HÉLÈNE), French princess: b. Versailles, 3 May 1764; d. Paris, 10 May 1794. She was a sister of Louis XVI. She was the faithful friend and companion of the royal family in their flight to Varennes, and during their imprisonment was executed, on the pretense of corresponding with her other brothers, afterward Louis XVIII and Charles X.

**ELIZABETH, Pauline Ottilie Luise**, dowager queen of Rumania (pseudonym "CARMEN SYLVA"): b. Neuwied, 29 Dec. 1843; d. Bucharest, 2 March 1916. Her father was Prince Hermann of Wied and her mother, Princess Marie of Nassau. She married Charles of Rumania, 15 Nov. 1869. She was the patroness of arts and letters in Rumania, did much to promote native artistic industries and founded several charitable institutions. She is well known as a writer over the signature "CARMEN SYLVA," her works including 'Sappho' (1880); 'Hammerstein' (1880); 'Stürme' (1881); 'Leidens Erdengang' ('Sorrow on Earth') (1882); 'Les pensées d'une reine' (1882); 'Pelesch Märchen' (1883); 'Le pic aux regrets' (1884); 'Es klopf' (1887). She was very much interested in collections of Rumanian legend and folklore. In English she wrote 'Pilgrim Sorrow,' 'A Real Queen's Fairy Tales' and 'From Memory's Shrine.' In 1882 she became a member of the Academy of Science at Bucharest, and in 1914 an honorary Fellow of the Royal Society of Literature of the United Kingdom.

**ELIZABETH, Saint**, of Hungary, daughter of Andrew II, king of Hungary, and Gertrude, daughter of the Duke of Carinthia: b. Presburg 1207; d. Marburg, 19 Nov. 1231. Early in life she displayed a dislike for things worldly, as the pomp with which she was surrounded, ambition, avarice and vain pleasures, and began to cultivate humility, piety and great charity. According to the custom of the times, when she was only four years old she was betrothed by her parents to Louis, the son of the Landgrave of Thuringia, who was about her own age. When Elizabeth was 14 years old they were married. Her husband admired his wife's piety and approved her great charity, especially during the famine in Germany in 1225, although members of his own family severely censured her. She founded hospitals in Marburg and other places within her husband's dominion. (Louis' father died the year after the betrothal, and he was the landgrave when he married Elizabeth). In 1227 Louis left home with Frederick Barbarossa to engage in the war for Palestine; but before reaching the Holy Land Louis died from fever. Great misfortunes soon befell Elizabeth. She was deprived of her regency by the brother of her deceased husband and driven out of her dominion on the plea that she wasted the treasures of the state by her charities. The inhabitants of Marburg, whose miseries she had frequently relieved, refused her any asylum, for fear of the new regent. At last she found refuge in the monastery of Kitzingen, where her aunt

was abbess, and later with her uncle, bishop of Bamberg, and when the warriors who had attended her husband in the Crusade returned from the East with his body, she gathered them around her, and recounted her sufferings and the wrongs done to her three children. Steps were taken to restore to her her sovereign rights. She declined the regency, however, and would accept only the revenues which accrued to her as landgravine. The remainder of her days were devoted to almsgiving, mortifications and prayer. She became a member of the Third Order of Saint Francis, and in pictures she is often represented clothed in the Franciscan habit. She was canonized by Gregory IX four years after her death. Consult Montalembert, 'Life of Saint Elizabeth of Hungary' (trans. into English by F. D. Hoyt 1904); Starr, 'Patron Saints'; Butler, 'Lives of Saints'; Bonaventure, 'Sermon on Saint Elizabeth'; Theodoric and Montague of Spire. There are extant manuscripts on her life, by contemporaries, Conrad of Marburg, Siegfried of Mentz, and others.

**ELIZABETH Farnese**, fār-nā'zē, queen of Spain: b. 25 Oct. 1692; d. 1766. She was a daughter of Edward II, Prince of Parma. On becoming the second wife of Philip V she surprised those who had counseled the marriage by assuming the practical headship of the kingdom; her ambition to place her sons Carlos and Philip in power over principalities in Italy and the aggressive policies of her Minister, Alberoni, disturbed the whole of Europe.

**ELIZABETH PETROWNA**, empress of Russia: b. 29 Dec. 1709; d. 5 Jan. 1762. She was the daughter of Peter the Great and Catharine, and ascended the throne on 7 Dec. 1741, as the result of a conspiracy, in which Ivan VI, a minor, who had reigned only one year, was deposed. Elizabeth is said to have rivaled her mother in beauty and to have surpassed her in her love of pleasure. Her reign was stained both by her unbridled licentiousness and the tyranny of her government, which was conducted by favorites. Banishment to the mines of Siberia and imprisonment in dungeons were awarded for the slightest political offenses. She was a patron of literature and corresponded with Voltaire, to whom she supplied materials for his 'Life of Peter the Great.' She also founded the University of Moscow and the Academy of Fine Arts of Saint Petersburg. Elizabeth sent an army, in 1748, to assist Maria Theresa in the war of the Succession, which contributed to bring about the Peace of Aix-la-Chapelle; and she joined in the Seven Years' War against Prussia. Consult Bain, 'The Daughter of Peter the Great' (London 1899).

**ELIZABETH STUART**, queen of Bohemia: b. Falkland Palace, Fifeshire, 16 Aug. 1596; d. London, 13 Feb. 1662. She was a daughter of James I of England and was married to the Palatine Frederick at Whitehall, 14 Feb. 1613. Her husband was then at the head of the Protestant interest in Germany, and in 1619 he accepted the crown of Bohemia offered to him by the revolted Protestants of that country. This he was only able to retain for a very short period; and after his defeat by the Imperialists at the battle of Prague in 1620, he and his wife were obliged to flee, first to Bres-

lau and Berlin, and then to The Hague. Elizabeth had 13 children, several of whom died early. Charles Louis, the eldest surviving, was reinstated in the palatine by the Treaty of Westphalia in 1648. His daughter, Elizabeth Charlotte, was the second wife of Philip, Duke of Orleans, brother of Louis XIV. Her descendants were excluded by their Catholicism from the crown of England, but one of them was regent of France during the minority of Louis XV; and another, Louis Philippe, ascended the throne after the revolution of 1830. Her sons, Princes Rupert and Maurice, distinguished themselves in the civil war in England. Her daughter, Sophia, married into the house of Brunswick, became electress of Hanover and mother of George I. Elizabeth Stuart's cause was extremely popular with the English nation and after her husband was deprived of the crown of Bohemia she still retained among them the endearing epithet of "Queen of Hearts." She returned to England at the Restoration with her nephew, Charles II. Consult Green, Mrs. E., 'Lives of the Princesses of England' (London 1854).

**ELIZABETH OF VALOIS**, vāl-wā', or **ISABELLA**, Queen of Spain: b. Fontainebleau, France, 22 Nov. 1545; d. Madrid, 3 Oct. 1568. She was a daughter of Henry II, of France, and Catherine de Medici. She was destined to be the wife of the infante, Don Carlos, but his father, Philip II, being left a widower, became fascinated and married her himself. The story of a romantic relationship between Elizabeth and Don Carlos has furnished tragic subjects to Otway, Campistron, Chénier, Schiller and Alfieri.

**ELIZABETH, N. J.**, city, county-seat of Union County, on Newark Bay and the Arthur Kill, and on the Pennsylvania, Lehigh Valley, Baltimore and Ohio, Philadelphia and Reading and New Jersey Central railroads, 14 miles southwest of New York. Elizabeth has a good harbor admitting vessels of 25 feet draught. Coal and iron reach tidewater here from the Pennsylvania fields and are transhipped here. The city has steamer communication with New York and is the residence of many who commute daily to the latter city. It has many fine homes and wide streets, well paved. The chief articles manufactured are sewing-machines (one of the shops of the Singer Manufacturing Company, employing about 10,000 people, being located here), oilcloth, hats, saws, mill-machinery, stoves, hardware, edge-tools, harness, cordage, combs, leather and rubber works, oil refineries, foundries, chemical works, ship-building plants, wire and cable, tools, electromotors, castings and bronze powder. The United States Census of Manufactures for 1914 showed within the city limits 184 industrial establishments of factory grade, employing 14,297 persons, 12,871 being wage earners, receiving \$8,198,000 annually in wages. The capital invested aggregated \$31,037,000 and the year's output was valued at \$31,228,000: of this, \$14,921,000 was the value added by manufacture. The shops of the Central Railroad, employing about 1,000 hands, and the Crescent Steel Works and shipyard are located here. There are three banks, one savings bank and a trust company with a combined capitalization of \$700,000 and deposits of \$7,154,000, and building and loan



associations. Among public institutions are the Alexian Brothers' Hospital, General Hospital, Saint Elizabeth Hospital, Orphan Asylum, Old Ladies Home and Public Library. The educational institutions include the Battin and Pingry high schools, the Vail-Deane School, a business college and 11 public schools. The city has electric lights and street railways, many handsome churches and contains an old tavern where Washington stopped on his way to New York for his inauguration. Gen. Winfield Scott's home the Boudinot House and the old Livingston Mansion are located here. It was settled in 1664 as Elizabethtown and four years later the first General Assembly of New Jersey met here. For two years after 1755 it was the capital of the Colony of New Jersey. During the Revolution it suffered from its position between the contending forces. In 1789 it was chartered as a borough, as a town in 1796, and as a city in 1855. Its revenue averages about \$2,250,000. In 1746 the college of New Jersey (now Princeton) was established here. Among its early citizens were the great rivals Alexander Hamilton and Aaron Burr. There are many fine types of architecture of the Revolutionary period still standing. Pop. 82,411. Consult Hetfield, 'History of Elizabeth' (New York 1868).

**ELIZABETH, Cape.** See CAPE ELIZABETH.

**ELIZABETH CITY, N. C.**, town, county-seat of Pasquotank County, on the Pasquotank River and the Norfolk and Southern and the Virginia and Carolina Coast railroads, about 145 miles northeast of Raleigh. A State normal school and United States custom-house are located here. The town has a good trade in the produce of the neighboring truck farms, also in cotton, fish and oysters. The region about is adapted for agriculture, lumbering and cotton raising. The manufactures of the town are varied, including cotton, saw- and planing-mills, shipbuilding, brick yards, carriage and wagon factories, shingle factories, hosiery mills, flour and grist-mills, ironworks, machine-shops, barrels and baskets, boxes, etc. The town was founded in 1793 and now has a government consisting of a mayor, elected every two years, a board of aldermen and a board of control. A naval victory was gained here by the Federals, 10 Feb. 1862. Pop. 9,292.

**ELIZABETH ISLANDS, Mass.**, group of 16 in number, forming the town of Gosnold, in Dukes County. They are situated between Vineyard Sound and Buzzards Bay; area, 14 square miles. In 1602 the first New England settlement was made on one of these islands, Buttyhunk, by Bartholomew Gosnold; but after a residence of a few weeks it was abandoned and Gosnold returned to England (see GOSNOLD, BARTHOLOMEW). The climate is healthful and the islands are popular with anglers and as a vacation resort. Naushon and Nashawena are the largest of the group, which in 1864 were incorporated as the town of Gosnold. Pop. 164.

**ELIZABETHAN ARCHITECTURE**, a style of architecture, which began to prevail in England during the reigns of Elizabeth and James I. It was a mixture of inferior Gothic with debased Italian, often very picturesque,

but without purity and unity of design. It was characterized by deeply embayed windows, galleries of great length, very tall and elaborate chimneys, strap work in the parapets and window-heads, and many dormanted details of surface-carving characteristic of the bizarre influence of the combined Renaissance forms from Germany and Holland. The names of Holbein and John of Padua are associated with this style of architecture in which they had hoped to revive classic models. The mansions erected for the nobility during the reigns of Elizabeth and James I are examples of this style of architecture, particularly the palace erected in the mixed style for Protector Somerset by John of Padua and the mansion of Longleat for his secretary, Sir John Thynne. Others which may still be seen near London and which represent the architecture of the 17th century are: Knowle, belonging to the Duke of Dorset, the Marquis of Salisbury's at Hatfield, Holland House, Campden House in Surrey, Bramshill in Kent, Sir T. Willow's at Charlton, Burton Agnes, Blickling, Montacute, Audley End, Mogus Park, Aston, etc. This style was succeeded by the Jacobean in which Gothic details disappeared. The greatest architects of the Elizabethan period were Gerard Christmas, John Thorpe, Thomas Holt and Rodolph Symonds. Consult Gotch and Brown, 'Architecture of the Renaissance in England' (London 1894); Richardson, 'Architectural Remains of the Reigns of Elizabeth and James I' (ib. 1840); Blomfield, 'History of Renaissance Architecture in England' (ib. 1897).

**ELIZABETHTOWN, Ky.**, city, county-seat of Hardin County, on the Louisville and Nashville and the Illinois Central railroads, about 40 miles south of Louisville. The city is the centre of the trade in asphalt for which the county is noted. It has flouring mills, stave and overall factories, and dairying interests, and carries on a considerable trade in live stock, grain, flour, fruit, brick and tobacco. It has municipal waterworks. Pop. 1,970.

**ELIZAVETPOL**, ě-lě-zā-vet-pol, or **YELIZAVETPOL, Russia**, (1) government of Transcaucasia, Asiatic Russia; area 16,991 square miles; pop. 1,098,000, of whom about 60 per cent are Azerbaijan Tartars, 30 per cent Armenians and the balance Kurds, Russians, etc. It is bounded on the north by Tiflis, Daghestan and Zakataly, east by Baku, south by Persia and west by Erivan. It belongs partly to the region of the Little Caucasus and is partly covered with steppes, in the west consisting of high mountains whereas the east is more level. The Kur River and several smaller streams are the chief waterways. Agriculture is the principal industry, the valleys being fertile and well cultivated. Wine is produced in considerable quantities; also cotton, the acreage in 1914-15 being 142,570 producing 23,652,500 pounds. The rearing of live stock is largely carried on in the steppes. The mountain slopes are well wooded and there are rich deposits of minerals, especially of copper, cobalt and iron ore which are found and mined in large quantities. The Transcaucasian Railway crosses the government, which is divided into eight districts, Elizavetpol, Zangizur, Aresh, Jebraïl, Javanshir, Shusha, Kazakh and Nukha.

(2) A city of the same name is the capital of the government, located on an affluent of the Kur River about 120 miles by rail southeast of Tiflis. It is situated in a rich agricultural region and besides trading in the agricultural products and fruit, the inhabitants are extensively engaged in the silk-worm industry. The city consists of two sections, the old and the new; the former is poorly built with crooked streets and low-roofed houses and is occupied chiefly by Mohammedans; the latter is well built and contains several handsome buildings, churches, mosques, etc., and a bazaar. Ancient remains are found in the vicinity of the city and the old Turkish fortifications may still be seen. The city changed hands between Persians, Arabs and Khozars as early as the 7th century, later came into the possession of the Mongols, Georgians, Persians and Turks, was taken by the Russians in 1796 and finally annexed to Russia in 1813, receiving its name in honor of Elizabeth, daughter of Alexander I. In 1826 the Persians were defeated here. Pop. 60,500.

**ELK**, the name of various deer, but originally and properly belonging to the great, flat-horned deer of northern Europe (*Alces machilis*), of which the American moose is substantially the counterpart, although regarded by naturalists as a distinct species. The European elk is now restricted to northern Russia, northern Scandinavia and the wilder forests of eastern Prussia; but in Pleistocene times it had a far more southerly range, together with other species now extinct. The great-antlered "Irish Elk," whose remains are found abundantly in peat-bogs and similar places not only in Ireland but in England and on the Continent, is not a true elk (*Alces*), but a deer of the genus *Cervus* related more nearly to our wapiti, despite the palmation of its horns. See MOOSE.

The American deer called elk, by the ignorance or carelessness of early colonists, is the large, round-horned stag, related not to the true elk but to the red deer of Europe, and the white-tailed and other deer of this country, and would better be called, as commonly nowadays by its Indian name Wapiti. See WAPITI; DEER.

**ELKESAITES.** See ELCESAITES.

**ELKHART**, Ind., city in Elkhart County, at the confluence of the Saint Joseph and Elkhart Rivers, and on the Cleveland, Cincinnati, Chicago and Saint Louis, the Lake Shore and Michigan Southern and other railroads, 101 miles east of Chicago. It is a railroad centre and shipping point for a large agricultural region. The rivers afford excellent water power. A large dam and power-house, erected in 1913 at a cost of \$750,000, furnishes abundant power for its industries, which include railroad shops, musical instrument factories, automobile works, bridge and iron works, and establishments for the manufacture of carriages, invalid tables, machinery, gocarts, corsets, telephone supplies, furniture, brass sundries, gas generators, paper boxes, rubber and paper. The United States census of manufactures for 1914 showed within the city limits 105 industrial establishments of factory grade, employing 3,815 persons; 2,993 being wage earners, receiving annually \$4,382,000 in wages. The capital invested aggregated \$9,511,000, and the

year's output was valued at \$8,649,000: of this, \$4,267,000 was the value added by manufacture. The city has a Carnegie library and a fine high school building. Elkhart is the seat of Elkhart Institute and has public schools, business colleges, daily and weekly newspapers, gas and electric lights, electric railways, waterworks and two national banks. The control of the government is vested almost entirely in the mayor and there is a city council. Pop. 21,028.

**ELKHORN**, a river in Nebraska formed by the junction, in Madison County, of the North Fork, which has its rise in Brown County, and the South Fork, which rises in Knox County. The general course is southeast, 260 miles, when it flows into the Platte River. Logan Creek is the largest tributary.

**ELKIN**, William Lewis, American astronomer: b. New Orleans, 29 April 1855. He was educated at the Royal Polytechnic School in Stuttgart, Germany, and was graduated in 1880 at the University of Strassburg. He then went to the Cape of Good Hope on the invitation of Sir David Gill, English astronomer there, and took part with him in observations with the heliometer for the determination of stellar parallax, these determinations being the most accurate of the kind ever made up to that time. He became astronomer in 1884 and director in 1896 of the Yale College observatory. His work there was mainly in the lines of determinations of stellar parallax, the solar parallax from asteroids and the photography of meteor trails.

**ELKINS**, Stephen Benton, American politician: b. Perry County, Ohio, 26 Sept. 1841; d. 4 Jan. 1911. He removed to Missouri when a child; was graduated at the University of Missouri in 1860; and admitted to the bar in 1864. During the latter year he went to New Mexico, where he was a member of the Territorial legislature in 1864-65; and the Territorial delegate in Congress in 1873-77. Subsequently he removed to West Virginia where he acquired large business interests. He married the daughter of Henry Gassaway Davis. He secured control of great coal fields in West Virginia and also became a large stockholder in several railroads, serving also as vice-president of the West Virginia Central and Pittsburgh Railroad. In 1891-93 he was Secretary of War and in 1894, 1900 and 1907 was elected to the United States Senate. The Elkins Railroad Law of 1903 bore his name. See ELKINS ACT.

**ELKINS**, W. Va., city and county-seat of Randolph County, on both sides of the Tygarts Valley River and on the West Virginia Cincinnati and Pennsylvania (Wabash) and its branches, the Coal and Iron and the Coal and Coke railways, 60 miles south of Grafton and 130 miles northwest of Charleston. Elkins is in the centre of vast timber areas, and nearby are large deposits of coal, glass, sand, limestone, potter's clay, fire clay and shale suitable for the manufacture of pressed brick and tiling. The industries include railroad car and machine shops, brick works, ice plant, foundries and machine shops, tannery, boiler works, pail factory, several planing mills, etc. The principal streets are paved with brick or macadamized limestone, and walks are laid with brick. The city owns the waterworks,

which pump the water from the Tygarts Valley River. The streets are lighted by electricity and natural gas is furnished for domestic and manufacturing purposes. There are a national bank and a trust company in the city, with combined capital of \$300,000 and deposits of about \$1,200,000. The city contains seven churches, representing the leading denominations. There are a graded public school and a high school. Elkins is also the seat of Davis and Elkins College and has an Odd Fellows home, two hospitals and an orphans' home. Under a charter of 1905 it is governed by a mayor, chosen annually, and a unicameral council. Pop. 6,000.

**ELKINS ACT**, a law enacted 19 Feb. 1903, to prevent secret railroad rebates and discriminations. The acceptance as well as the offer of a rebate or unlawful discrimination was a violation of the law; the published rate was declared to be the only lawful charge, and the United States Circuit Courts were authorized to enjoin carriers to charge only the published rates. The penalty was not less than \$1,000 nor more than \$20,000 for each offense, the corporation as well as the officer giving the rebate receiving the penalty. The law was most effective and with slight changes was incorporated in the Hepburn Act (1906) and the Mann-Elkins Act (1910). See DIFFERENTIALS IN RAILROAD TRAFFIC; SHERMAN ANTI-TRUST ACT.

**ELKS, Benevolent and Protective Order** of, a fraternal association, founded in 1868 in New York from an older social and benevolent society, the Jolly Corks. The grand lodge was incorporated 10 March 1871, and was composed of past members of New York Lodge No. 1, the premier regular association. In the same year it was empowered to form branch lodges. Lodges were formed in Philadelphia, San Francisco, Chicago, Cincinnati, Sacramento, Baltimore, Louisville, Saint Louis, Boston, Pittsburgh, Indianapolis, Providence, Washington and Denver and in every other city of any size throughout the country. The order has been noted for the prompt assistance given its members and also its ready response to calls for aid from the outside. In all great calamities of recent years it gave liberally of its funds to aid the needy. Its membership is close to 500,000, and its annual disbursements are about \$600,000. There are 1,392 lodges, and subordinate lodges in Alaska and the island possessions of the United States. White male citizens of 21 years or over and of good character are eligible for membership. In any city there may be but one lodge, and the population of such city must be at least 5,000. On the first Sunday of December is held a memorial service for the deceased members of the order. Property and cash to the extent of over \$11,000,000 are owned by the order. Its official organ is the *Elks Aniler*, a monthly published in New York. Consult Ellis, C. E., 'Authentic History of the Benevolent and Protective Order of Elks' (Chicago 1910).

**ELKTON**, Md., town and county-seat of Cecil County, 50 miles northeast of Baltimore, on the Philadelphia, Baltimore and Washington Railroad and on the Elk River. It contains a hosiery mill, fertilizer works, boat yards, textile mills and pulp mills. First settled in 1681. Elkton was incorporated in 1787. It has

adopted the commission form of government. Pop. 2,487.

**ELKUS, Abram Isaac**, American lawyer and diplomat: b. New York, 6 Aug. 1867. He was educated at the College of the City of New York and at Columbia. He has been prominent at the New York bar since 1888 and was considered by President Wilson for a place on the Federal court in New York. He is one of the leaders of the American Jewry and has frequently appeared for Jewish immigrants who have faced detention at Ellis Island and deportation because they had less than \$25 in cash when they reached this country.

In 1896 he became a member of the law firm of James, Schell and Elkus. On the deaths of his partners he became senior member in the firm now known as Elkus, Gleason & Proskaner. He has appeared in all branches of his profession. He was elected by the United States judges as a special United States attorney to prosecute fraudulent bankruptcy cases and met with great success in that work.

He acted as counsel for the Merchants' Association and president of the Hebrew Technical School and as trustee of the Baron de Hirsch Fund. In July 1916 he was nominated by President Wilson as Ambassador to Turkey to succeed Henry Morgenthau, who had retired to become chairman of the finance committee of the Democratic national committee. He is the author of a treatise on 'Secret Liens and Reputed Ownership.'

**ELL**, an old linear measure, originally denoting the length of the forearm and later denoting different lengths. The English ell equalled one and one-quarter yards (45 inches).

**ELLAGIC ACID** or **BEZOARIC ACID**,  $C_{12}H_6O_6$ , is separated from Oriental bezoar stones (concretions found in the stomachs of goats and other animals which have fed upon plants containing ellagitannin) by dissolving them in cold strong potash, away from the air, passing a current of carbonic acid, collecting the ellagate of potassium, washing and recrystallizing it, and then liberating the ellagic acid by hydrochloric acid. When crystallized from pyridine it forms prismatic needles. After washing these with alcohol ellagic acid becomes pale yellow, tasteless, crystalline powder, insoluble in water, decomposing at 680°, at which temperature it has still refused to melt. With the bases it forms salts, which are not very well known; they are crystalline and insoluble or sparingly soluble in water. The lead and barium compounds are yellow. This acid can be prepared synthetically by oxidizing gallic acid with arsenic acid. Though not in itself a tanning agent it is considered of great value in the tanning industry.

**ELLE ET LUI** ('She and He') is a novel by George Sand which excited a good deal of comment and enjoyed a kind of celebrity because it was accepted as her version of her unfortunate love affair with Alfred de Musset. After the rupture which brought to a pitiful end their Venetian adventure (1834), many bitter accusations were brought against each by the friends and partisans of the other, and neither hesitated to exploit the experience for literary purposes. George Sand's 'Lettres

d'un Voyageur,' written immediately afterward, already drew largely upon it and echoes of it are frequent in the subsequent poetry of Musset (*Nuit de mai, Souvenir*) and in his 'Confession d'un enfant du siècle.' The appearance of 'Elle et Lui' (1859) shortly after the poet's death (1857) revived the bitter memories and recriminations of the affair. It was evidently substantially the story of their relations, under the transparent disguise of a novel, though George Sand's intention, as she tells us elsewhere, was not to tell their story, but to 'present, under the veil of fiction, a certain situation in which others than they may have found themselves.' It provoked from Paul de Musset, Alfred's brother, the answering volume, 'Lui et Elle,' in the poet's defense. The 'true story' of 'Elle et Lui' has been told by Spoelberch de Louvenjoul ('La véritable histoire de Elle et Lui,' *Notes et documents*, 1897). The original correspondence of George Sand and Alfred de Musset has been published by Félix Decori (1904).

ARTHUR G. CANFIELD.

**ELLENBOROUGH**, ɛl'ɛn-būr-ō, Edward Law, Lord, English lawyer: b. Great Salkeld, Cumberland, 16 Nov. 1750; d. London, 13 Dec. 1818. He was educated at Cambridge, became the pupil of the celebrated special pleader, George Wood, in 1771, and was called to the bar in 1780. In 1787 he was made a king's counsel. On the trial of Warren Hastings in 1788, Erskine having refused to undertake the defense, Law served as leading counsel. It required no little courage to encounter such opponents as Burke, Fox, Sheridan and other eminent men of the time, who conducted the impeachment. Law, as is well known, obtained the victory. In 1801 he was made Attorney-General and in 1802 became Lord Chief Justice of the king's bench and was created baron. In Parliament he opposed the emancipation of the Catholics. Believing that the criminal laws were not severe enough he succeeded in establishing 10 new capital felonies by the passage of the so-called Ellenborough Act, afterward repealed in toto. He held the office of chief justice for 15 years.

**ELLENBOROUGH**, Edward Law, 1st EARL OF, English statesman: b. 8 Sept. 1790; d. near Cheltenham, 22 Dec. 1871. He was educated at Eton and Cambridge; entered Parliament as representative of Saint Michael's in 1814, and in 1818 succeeded his father as 2d baron and entered the House of Lords. He was Lord Privy Seal in 1828, and in 1841 accepted the governor-generalship of India. He arrived in Calcutta in time to take control of the Afghan war, which was brought to a successful issue. Scinde was conquered by Sir Charles Napier and annexed in 1843. This was followed by the conquest of Gwalior. The conduct of the governor-general, however, gave great dissatisfaction at home. He was consequently recalled by the East India Company early in 1844. Under Lord Derby's government in 1858 he held the office of President of the Board of Control from February to June, during which he wrote a dispatch censuring the policy of Lord Canning as governor-general of India, which caused much discussion and led him to resign his office.

**ELLENVILLE**, N. Y., village of Ulster County, at the foot of Shawagunk Mountain, on the main line and on the Ellenville and Kingston division of the New York, Ontario and Western Railroad, 18 miles north of Middletown. The first house was built in 1805, a post office established in 1823 and the village incorporated in 1856. It has several denominational churches, a high school and other educational establishments, two national and one savings banks, and its industries include zinc mining, manufactures of cutlery, paints, handkerchiefs and shirt waists, overalls, artificial stone, and wooden wares, employing about 300 operatives. Ellenville is a popular summer resort. It has finely shaded streets and is near several places of interest, including Mount Meenahga, the Ice Caves, Sun Ray Spring and many beautiful waterfalls. The village owns its waterworks. Pop. 3,114.

**ELLER**, Johann Theodor, German chemist: b. Plötzkau, in Anhalt-Bernburg, 29 Nov. 1689; d. Berlin, 13 Sept. 1760. In 1721 he was appointed Anhalt-Bernburg physician; in 1724, professor of anatomy in Berlin; in 1735, physician to Frederick the Great; in 1755, privy councillor and director of the physical class of the Academy of Sciences. His papers were published in the 'Memoirs of the Berlin Academy,' and among them is a long and interesting review of the opinions held respecting the elements from the earliest times down to his own day. He also published a series of curious microscopic observations upon the change of blood corpuscles by the addition of different salts, tinctures of plants and other solutions. Eller was undoubtedly a man of great learning and abilities, but his writings do not indicate a high degree of originality.

**ELLERIANS**, a sect of fanatics which arose in 1726, and had for its founder Elias Eller, a ribbon-weaver, who was born in 1690 at Ronsdorf in Berg. He was influenced in his religious beliefs by reading the works of Jacob Böhme, and other mystical writings. The sect committed great excesses, and became very numerous. See BÖHME, JACOB.

**ELLERY**, William, American patriot: b. Newport, R. I., 22 Dec. 1727; d. there, 15 Feb. 1820. He sat in the Congress of 1776, and was one of the signers of the Declaration of Independence. He became Chief Justice of Rhode Island in 1785 and in the following year commissioner of the Continental Loan Office for Rhode Island. From 1790 till his death, he retained the office of collector in his native place.

**ELLESMERE LAND**, the most northern region of the continent of North America, discovered by Baffin in 1616. The western part of this region was explored and mapped by Otto Sverdrup (q.v.) in 1899. Ellesmere Land is a high plateau, without human inhabitants; a few reindeer, musk-oxen and wolves find sustenance there. It is separated from Greenland by Smith Sound. Consult Sverdrup's account of his discoveries: 'Four Years in the Arctic Region' (2 vols., New York 1904).

**ELLET**, Charles, American engineer: b. Penn's Manor, Bucks County, Pa., 1 Jan. 1810; d. Cairo, Ill., 21 June 1862. He was educated at the Polytechnic School in Paris, and on his return to America held various responsible en-

gineering posts. He built at Fairmount, Philadelphia, the first wire suspension bridge in the United States, and in 1845 built at Niagara below the Falls a suspension bridge adapted for railway purposes. He constructed also the railway suspension bridge at Wheeling, W. Va., which is owned by the Baltimore and Ohio Railroad. In the Civil War he became colonel in the engineering corps and equipped nine Mississippi River steamboats as rams, and with them defeated a fleet of Confederate rams, but died of wounds on that occasion.

**ELLET, Elizabeth Fries Lummis**, American prose writer: b. Sodus Point, N. Y., October 1818; d. New York, 3 June 1877. She was popular in her day, and among her books are a translation of Silvio Pellico's 'Euphemia of Messina' (1834); 'Poems, Original and Selected' (1835); 'Characters of Schiller' (1842); 'Pioneer Women of the West' (1852); 'Novellettes of the Musicians' (1852); 'Queens of American Society' (1867); 'Court Circles of the Republic,' with Mrs. R. E. Mack (1869); 'The Practical Housekeeper'; 'Evenings at Woodlawn'; 'Women Artists in All Ages.'

**ELLICE**, ɛl'is, or **LAGOON ISLANDS**, a group of coral islands, situated north of the Fiji and northwest of the Samoan group between lat. 5° and 11° S. and long. 176° and 180° E. They extend for 360 miles in the direction northwest to southeast, and form nine groups, the largest islands being Sophia or Rocky Island, Nukulailai or Mitchell, Elice, Nukufetau, Vaitupu, Netherland and Lynx. The inhabitants almost all speak a Samoan dialect, and have traditions of a migration from the Samoan Islands. They have long been Christianized, and reading and writing are general. The islands are of coral formation. Guano, yams, fruit, coconuts and copra are the chief products. They were discovered in 1781 by Maurelle, and were annexed by Great Britain in 1892. Area, 15 square miles. Pop. 3,084.

**ELlichPUR**, ɛl-ich-poor', India, town in Amraoti district, Berar, on the Bichan, 32 miles northwest of Amraoti and was once large and prosperous. It contains manufactories of cottons and carpets, and is an important trading centre in lumber. Imperial troops have a regular station here. The town contains many interesting ruins, including a palace and several fine tombs. Pop. 13,909.

**ELlicOTT, Andrew**, American astronomer and civil engineer: b. Bucks County, Pa., 24 Jan. 1754; d. West Point, N. Y., 28 Aug. 1820. His father founded the town of Ellicott's Mills, Md., where the younger days of his son Andrew were devoted to the study of the sciences and practical mechanics. The latter's scientific attainments early attracted public attention, and from the Revolution to the day of his death he was employed in the fulfilment of trusts conferred by the general or State governments. About 1785 he removed to Baltimore, and represented the city in the State legislature. In 1789 he was appointed by President Washington to survey the land lying between Pennsylvania and Lake Erie, and during that year made the first accurate measurement of the Niagara River from lake to lake, with the height of the falls and the fall of the rapids. In 1790 he was employed by the government to

survey and lay out the Federal metropolis. In 1792 he was made Surveyor-General of the United States, and in 1795 superintended the construction of Fort Erie at Presque Isle (now Erie, Pa.), and was employed in laying out the towns of Erie, Warren and Franklin. In 1796 he was appointed by President Washington commissioner on behalf of the United States under the Treaty of San Lorenzo el Real, to determine the southern boundary separating the United States territory from the Spanish possessions. The results of this service, embracing a period of nearly five years, appear in his 'Journal' (published 1803). Upon the completion of this service he was appointed by Governor McKean of Pennsylvania secretary of the State land office, the duties of which he performed to the year 1808, and in 1812 became professor of mathematics at West Point. In 1817, by order of the government, he proceeded to Montreal to make astronomical observations for carrying into effect some of the articles of the Treaty of Ghent.

**ELlicOTT, Charles John**, Anglican prelate: b. Whitwell, Stamford, England, 25 April 1819; d. 15 Oct. 1905. He was educated at Saint John's College, Cambridge, and after being professor of divinity in King's College, London, Hulsean lecturer and professor of divinity at Cambridge, and dean of Exeter, was appointed bishop of Gloucester and Bristol in 1863. In 1897 the diocese of Bristol was separated from that of Gloucester, Bishop Ellicott remaining at the head of the latter diocese. He was for 11 years chairman of the scholars engaged on the revision of the New Testament translation, and published commentaries on the Old and New Testament, as well as 'Historical Lectures on the Life of Christ' (1860); 'Modern Unbelief' (1877); 'Some Present Dangers of the Church of England' (1878); 'The Revised Version of Holy Scripture' (1901), which is the best popular account of the work of the revisers, etc.

**ELlicOTT CITY**, Md., city and county-seat of Howard County, on the Patapsco River, nine miles west of Baltimore, and on the Baltimore and Ohio Railroad. Saint Charles College (R. C.) in charge of secular clergy, and Rock Hill College, in charge of Brothers of the Christian Schools, are located here. It has manufactures of flour, cotton, silk and woolen goods. Founded in 1772, Ellicott City was incorporated in 1867.

**ELLIOT, Arthur Ralph Douglas**, English lawyer: b. 17 Dec. 1846. He is second son of the 3d Earl of Minto, was educated at Edinburgh University and at Trinity College, Cambridge. From 1880 to 1892 and from 1898 to 1906 he was a member of Parliament. In 1903 he was Financial Secretary to the Treasury and from 1895-1912 was editor of the *Edinburgh Review*. He has published 'Criminal Procedure in England and Scotland' (1878); 'The State and the Church' (1881; 2d ed., 1889); 'Life of the First Viscount Goschen' (1911).

**ELLIOT, Benjamin**, American jurist: b. Charleston, S. C., 1786; d. 1836. He was graduated at Princeton in 1806, studied law, was admitted to the bar in 1810 and entered on his practice in his native State of South Carolina. He was the author of numerous literary,

historical and political productions. Among his works is a 'Refutation of the Calumnies circulated against the Southern and Western States respecting the Institution and Existence of Slavery' (1822). He also prepared and published 'The Militia System of South Carolina,' which was adopted as the military code for the State.

**ELLIOT, Daniel Giraud**, American zoologist: b. New York, 7 March 1835; d. 22 Dec. 1915. He made zoology a special study from his youth; traveled in Europe, Africa and parts of Asia in 1856-78; subsequently in Canada, Alaska, South America and the greater part of the United States. He afterward became curator of zoology in the Field Columbian Museum. He has published 'The Pheasants' (1871-72); 'Birds of North America' (1897); 'The Grouse' (1865); 'Birds of Paradise'; 'Hornbills' (1877-82); 'North American Shore Birds' (1895); 'Gallinaceous Game Birds of North America' (1897); 'Synopsis of the Mammals of North America and the Adjacent Seas' (1901); 'A Review of the Primates' (Vols. I-III, 1913). He has been decorated 10 times by various European governments for his researches in natural science.

**ELLIOT, Sir Gilbert**, Scottish philosopher and poet: b. Teviotdale, September 1722; d. Marseilles, 11 Jan. 1777. His song of 'Amynta' beginning "My sheep I neglected, I broke my sheep hook," is famous; he also wrote occasional philosophical papers.

**ELLIOTT, Charles**, American Methodist clergyman: b. Glenconway, County Donegal, Ireland, 16 May 1792; d. Mount Pleasant, Iowa, 3 Jan. 1869. He came to the United States in 1814 and became prominent in the Methodist denomination. He was a professor of languages at Madison College, Uniontown, Pa., 1827-31, and president of Iowa Wesleyan University 1856-60 and 1864-67. He was editor of *The Western Christian Advocate*, Cincinnati 1836-48, *The Central Christian Advocate*, Saint Louis 1852-56. He published 'Treatise on Baptism' (1834); 'Delineation of Roman Catholicism' (2 vols., 1841); 'Life of Robert R. Roberts' (1844); 'Sinfulness of American Slavery' (1851); 'The Bible and Slavery,' etc. His most important book was 'The History of the Great Secession from the Methodist Episcopal Church in the year 1845.' 'Southwestern Methodism' was edited by L. M. Vernon (1868).

**ELLIOTT, Charlotte**, English hymn-writer: b. 17 March 1789; d. Brighton, 22 Sept. 1871. She wrote a number of religious poems, which were published under the titles 'Hymns for a Week'; 'Hours of Sorrow'; 'Invalids' Hymn Book.' The last collection included 'Just as I Am,' a hymn which is widely used, and has been translated in "almost every living language."

**ELLIOTT, Edward Charles**, American educator: b. Chicago, Ill., 21 Dec. 1874. He was graduated at the University of Nebraska in 1895, studied also at Jena and at Columbia University. In 1898-1903 he was superintendent of schools at Leadville, Colo., in 1905-07 associate professor, and after 1907 professor of education at the University of Wisconsin, where after 1909 he also served as director of the pedagogi-

cal seminar. In 1906-10 he conducted special investigations for the United States Bureau of Education, in 1911-12 for the New York Board of Education and in 1913 for the State of Vermont. He has published 'Some Fiscal Aspects of Public Education in American Cities' (1905); 'State School Systems' (3d ed., 1910); 'Legislation upon Industrial Education in the United States' (1910); 'City School Supervision' (1914).

**ELLIOTT, Jesse Duncan**, American naval officer: b. Maryland 1782; d. 1845. He entered the United States navy as a midshipman 1804, and in October of 1812 won the first American naval success on the lakes, capturing two British brigs, the *Detroit* and the *Caledonia*, near Fort Erie. He commanded the *Niagara*, in the battle of Lake Erie, September 1813, being second in command to Perry, whom he succeeded in October of the same year as commander of the Lake Erie fleet. In 1815, during the war against Algiers, he was in command of the sloop of war *Ontario*, under Decatur, being appointed captain in 1818. He was court-martialed and suspended for four years, after his service in the Mediterranean squadron. He resumed his duties in 1843 and was given charge of the Philadelphia navy yard.

**ELLIOTT, Maud Howe**, American novelist: b. Boston, Mass., 9 Nov. 1854. She is a daughter of Julia Ward Howe (q.v.), and was married to John Elliott, an artist, in 1887. Her writings include 'A Newport Aquarelle' (1883); 'The San Rosario Ranch' (1884); 'Atlanta in the South' (1886); 'Mammon' (1888); 'Honor'; and 'Phyllida' (1903); 'Roma Beata' (1904); 'Two in Italy' (1905); 'Sun and Shadow in Spain' (1908); 'Sicily in Shadow and in Sun' (1910); 'The Eleventh Hour in the Life of Julia Ward Howe' (1911); 'Life and Letters with Julia Ward Howe,' with Laura E. Richards (1915).

**ELLIOTT, Maxine**, American actress: b. Rockland, Me., 5 Feb. 1873, daughter of Thomas and Adelaide Dermot. Making her debut with E. S. Willard, she played Felicia Umfraville in 'The Middleman' (1890), and later in 'The Professor's Love Story.' She was with Rose Coghlan, and in 1895 went to London with Augustin Daly's company. A member of N. C. Goodwin's company 1896, she played in Clyde Fitch's 'Nathan Hale' (1898); was married to Mr. Goodwin that year, appeared with him in 'When We Were Twenty-One,' and played Portia in the 'Merchant of Venice' (1901). She starred in Fitch's 'Her Own Way' in 1903 and thereafter appeared in several light comedies. She is owner and manager of the Maxine Elliott Theatre, New York, since 1908. She appeared there in 'The Chaperon' and 'Deborah of Tods,' etc. She has since appeared in the film drama and with the greatest success.

**ELLIOTT, Sarah Barnwell**, American novelist. She is a granddaughter of Stephen Elliott. Her best-known works are 'The Felmeres' (1879); 'Jerry'; 'John Paget'; 'The Durket Sperrret' (1898); 'An Incident and Other Happenings' (1899); 'Sam Houston' (1900); 'The Making of Jane' (1901); and a play 'His Majesty's Servant.' She is a member of the Society of Colonial Dames and the United Daughters of the Confederacy.

**ELLIPSE** (Lat. *ellipsis*, from Gr. *elleipsis*, omission), a plane curve of such a form that, if from any point in it two straight lines be drawn to two given fixed points, the sum of these straight lines will always be the same. The ellipse is a species of conic section (q.v.), and is obtained by a plane which cuts all the elements of one nappe of a right circular cone. Projectively considered, an ellipse is a conic which cuts the line of infinity in two distinct imaginary points. If these are the two circular points, the ellipse becomes a circle. These two fixed points are called the foci. In the ellipse A B C D E and F are the foci. If a straight line (E Q F) be drawn joining the foci, and be

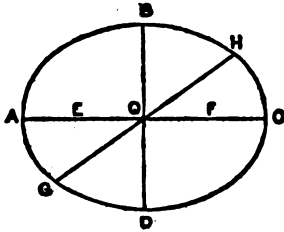

then bisected, the point of bisection is called the centre. The distance from the centre to either focus (E Q or Q F) is called the linear eccentricity. The straight line (G Q H), drawn through the centre and terminated both ways by the curve, is called the diameter. Its vertices are G and H. The diameter A C, which passes through the foci, is called the major axis; the points in which it meets the curve (A and C), the principal vertices. The diameter (B D), at right angles to the major axis, is called the minor axis. Practically, a tolerably accurate ellipse may be drawn on paper by sticking two pins in it to represent the foci, putting over these a bit of thread knotted together at the ends, inserting a pencil in the loop, and pulling the string tight as the figure is described. The importance of the ellipse arises from the fact that the planets move in elliptical orbits, the sun being in one of the foci—a fact which Kepler was the first to discover.

The equation to an ellipse, referred to its centre as origin, and to its major and minor axes as rectangular axes, is

$$\frac{x^2}{a^2} + \frac{y^2}{b^2} = 1, \text{ where } a \text{ and } b \text{ are the semi-major}$$

and semi-minor axes respectively. From this equation it may be shown, by the integral calculus, that the area of an ellipse is equal to  $\pi ab$ ; or is got by multiplying the product of the semi-major and semi-minor axes by 3.1416. It may also be shown that the length of the circumference of an ellipse is got by multiplying the major axis by the quantity

$$\pi \left\{ 1 - \left( \frac{1}{2} \right)^2 \frac{e^2}{1} - \left( \frac{1.3}{2.4} \right)^2 \frac{e^4}{3} - \left( \frac{1.3.5}{2.4.6} \right)^2 \frac{e^6}{5} - \&c. \right\}$$

The eccentricity  $e$ , is  $= \sqrt{1 - \frac{b^2}{a^2}}$  and the

ellipticity is the ratio  $a-b$  to  $a$ . See GEOMETRY and CONIC SECTIONS.

**ELLIPSIS**, in grammar, the omission of one or more words, which may be easily sup-

plied by the connection. It is common, especially in colloquial language, for the sake of brevity, and frequently adds to the strength and perspicuity of the sentence; hence a more extended use of the ellipsis in rhetoric and poetry. In the hands of a genuine poet or orator the ellipsis has a very telling value. In natural language, from the brevity it affords, the ellipsis becomes in all its phases the language of passion, and especially of sudden and intense emotion; and the imitation of its natural use in this way is to the poet the most powerful instrument for painting passion to the life. The works of all the greater poets, and especially the Hebrew poetry of the Old Testament, abounds with familiar instances of this use of the ellipsis.

**ELLIPSOID**, in geometry, a real quadric surface with no real points at infinity. Its equation may be reduced by a transformation

$$\text{of axes to } \frac{x^2}{a^2} + \frac{y^2}{b^2} + \frac{z^2}{c^2} = 1, \text{ } a, b \text{ and } c$$

being real. Every real plane section of an ellipsoid is an ellipse. If  $a, b$  and  $c$  are not all distinct, the ellipsoid is a figure of revolution, and is known as a spheroid. An oblate spheroid is one where the axis of revolution is less than the chords of the spheroid bisecting it perpendicularly; a prolate spheroid is one where the chords are less.

**ELLIPSOIDAL STRUCTURE IN IGNEOUS ROCKS.** Certain extrusive igneous rocks when viewed at a distance seem to be made up of aggregates of bowlders varying from a few inches to several feet in diameter. If these masses are studied more closely, however, they are seen not to be bowlders at all, but merely ellipsoidal shaped masses of the rock that have a slightly different texture and color from the remaining mass. This difference is believed to be the result of certain differences set up during the cooling and solidification of the molten rock. The cause is obscure but there is some reason to believe that it is due to the lava being poured out into a body of water, as in a lake or the ocean.

**ELLIS, Alexander John** (originally **Sharpe**), English scientist and philosopher: b. Hoxton, 4 June 1814; d. London, 28 Oct. 1890. He was educated at Shrewsbury, Eton and Trinity, Cambridge, and devoted himself to mathematics, the scientific side of music, and more especially to philology and phonetics. His translation of Professor Helmholtz's 'Sensations of Tone' (1875) has taken a place as a standard work on scientific music. In 1848 he published two small works: 'The Essentials of Phonetics'; and 'A Plea for Phonetic Spelling,' and collaborated with Sir Isaac Pitman (q.v.) in framing a phonetic system. His *magnum opus* on 'Early English Pronunciation,' with special reference to Chaucer and Shakespeare, appeared between 1869 and 1889. His other works include 'Horse Taming' (1842); 'Phonetics' (1844); 'On Glosik, a Neu Sistem ov English Speling' (1870); 'English Dyonisian and Hellenic Pronunciations of Greek' (1876); 'Logic for Children' (1882), which consists of two addresses; 'Original Nursery Rhymes for Boys and Girls' (1848); 'Algebra Identified with Geometry' (1874); 'Practical Hints on the Quantitative Pronuncia-

tion of Latin' (1874); 'Pronunciation for Singers' (1877).

**ELLIS, Alston**, American educator: b. Kenton County, Ky., 26 Jan. 1847. He was graduated at Miami University in 1865 and from 1867 to 1892 was principal of schools at Covington and Newport, Ky., and superintendent of schools at Hamilton and Sandusky, Ohio. From 1892 to 1900 he was president of the State Agricultural College of Colorado and for the greater part of that time served also as director of the Colorado Experiment Station. In 1901 he was chosen president of Ohio University. He was president of the Ohio Superintendents' Association in 1875, of the Ohio Teachers' Association in 1888, of the Ohio College Association in 1892-93, and of the Ohio Association of Presidents and Deans in 1910-11. He published a 'History of the Ungraded Schools of Ohio,' and many educational reports.

**ELLIS, Edward Sylvester**, American writer of school textbooks and juvenile literature: b. in Geneva, Ohio, 11 April 1840. For some years he was superintendent of public schools at Trenton, N. J. He has published more than 100 juveniles, most of which have been reissued in London and are sold in every part of the world. He is joint author of 'The World's Great Events,' and of a school history of New Jersey. His 'History of the United States' (8 vols., Cincinnati 1887) has sold to the extent of 114,000 sets or 912,000 separate volumes. A number of his historical productions have appeared in the moving pictures. His latest literary work is the editing of some 60 translations, devoted to a full history of all the nations engaged in the great European War.

**ELLIS, George**, English author: b. London, England, 1753; d. 10 April 1815. He was educated at Westminster School and Trinity College, Cambridge, and was one of the junta of wits concerned in the well-known political satire, 'The Rolliad.' He published 'Specimens of the Early English Poets, with an Historical Sketch' (1790); 'Specimens of Early English Metrical Romances' (1805); and was an intimate friend of Sir Walter Scott.

**ELLIS, George Edward**, American Unitarian clergyman and historical writer: b. Boston, Mass., 8 Aug. 1814; d. there, 20 Dec. 1894. He was pastor of the Harvard (Unitarian) Church, Charlestown, Mass. (1840-69); and held the professorship of systematic theology in the Cambridge Divinity School (1857-63). He was also a lecturer of Lowell Institute in 1864, 1871 and 1879, and was editor of the *Christian Register* and *Christian Examiner*. As president of the Massachusetts Historical Society he made valuable contributions to an early colonial history. He published 'A Half-Century of the Unitarian Controversy' (1857); 'History of the Battle of Bunker's Hill' (1875); 'The Red Man and the White Man' (1882); 'The Puritan Age and Rule in the Colony of Massachusetts Bay, 1629-85'; various memoirs, and several biographies in Sparks' 'American Biography.'

**ELLIS, Henry Havelock**, English scientist and literary scholar: b. Croydon, Surrey, 2 Feb. 1859. He taught school in New South Wales 1875-79, and on his return to England practised

medicine for a short time and then devoted himself to literary and scientific work. He was editor of the 'Contemporary Science Series' (1889); and of the 'Mermaid Series of Old Dramatists' (1887-89); and is the author of 'The New Spirit' (1890); 'The Criminal' (1890); 'Man and Woman: a Study of Human Secondary Sexual Characters' (1894); 'Sexual Inversion' (1897); 'Affirmations' (1897); 'The Evolution of Modesty' (1899); 'Analysis of the Sexual Impulse' (1903); 'Sexual Selection in Man' (1905); 'Erotic Symbolism' (1906); 'Sex in Relation to Society' (1910); 'The World of Dreams' (1911); 'Impressions and Comments' (1914).

**ELLIS, John**, English naturalist: b. Ireland about 1710; d. 1776. He was the first who suggested the idea that the South Sea islands were constructed and raised from the bottom of the ocean by means of zoophytes or the polypi inhabiting different species of coral ('Essay towards the Natural History of Corallines' 1755). He was for some time agent for the colony of West Florida and the island of Dominica. Among his works is a posthumous one entitled 'The Natural History of Many Uncommon Zoophytes' (1786).

**ELLIS, John Valentine**, Canadian statesman: b. Halifax, Nova Scotia, 1835. He was educated in the public schools of his native city; worked several years in a printer's office and in 1857 removed to Saint John, New Brunswick, where he became a reporter. He bought the *Globe* of that city in 1862 and thereafter was its editor and publisher. In 1882 he entered the political arena, served in the New Brunswick legislature as Liberal for Saint John from 1882-87. In the latter year he went to the House of Commons as member for Saint John. In connection with his election court proceedings were instituted which involved Ellis in contempt of court and he was imprisoned and fined. His popularity was greatly increased by these proceedings and the fine was made up by public subscription. He sat in the Commons until 1891, was again elected in 1896 and in 1910 became a member of the Senate. In 1911 he was chairman of the Senate Committee on Debates and in the same year was also president of the Natural History Society of New Brunswick.

**ELLIS, John Willis**, American statesman: b. Rowan County, N. C., 25 Nov. 1820; d. Raleigh, N. C., 1861. He was graduated at the University of North Carolina in 1841, was admitted to the bar in 1842 and soon acquired a large practice. He was a member of the State House of Commons from 1844 to 1848, when he was elected a judge of the Superior Court of North Carolina. This office, in which he succeeded his former preceptor, R. M. Pearson, who was elevated to the Supreme bench, he held until 1858, when he was elected governor of North Carolina. He was re-elected in 1860 and died in office. On 2 Jan. 1861, Governor Ellis took possession of Fort Macon at Beaufort, the works at Wilmington and the Federal arsenal at Fayetteville, professedly on behalf of the State. On 20 April he ordered the seizure of the United States mint at Charlotte. He was active in promoting the passage of the secession ordinance in North Carolina.



**ELLIS, Mina A.**, Canadian explorer: b. Bewdley, Ontario, about 1875. She was graduated at the Brooklyn (N. Y.) Training School for Nurses; later became assistant superintendent of the S. R. Smith Infirmary (now the Staten Island Hospital) and superintendent of the Virginia Hospital, Richmond, Va. She married Leonidas Hubbard, journalist and explorer, in 1901; he perished two years later in Labrador. She organized an expedition and in 1905 succeeded in completing the exploration work undertaken by her husband by crossing the northeastern part of Labrador, now known as the District of Ungava, Province of Quebec. She was the first white person to cross the ridge dividing the Naskaupi and George watersheds. An account of the expedition, which resulted in some important discoveries, is given in her 'A Woman's Way through Unknown Labrador' (1908) and in 'The Bulletin of the American Geographical Society.'

**ELLIS, Powhatan**, American jurist and politician: b. Virginia, about 1794; d. Richmond, Va., about 1844. In 1813 he was graduated at William and Mary College, settled in Mississippi while it was a Territory, gained a high reputation as a lawyer and in 1818 was raised to the supreme bench of the State, being one of the first judges of that court. He remained in office until 1825, when he was appointed by the governor to serve out the unexpired term of David Holmes in the United States Senate. He failed of election by the legislature, but at the next election he was chosen senator for a full term, but served only from 3 Dec. 1827 to 1832, when he resigned to take his seat on the bench as United States judge for the district of Mississippi. While in the Senate he joined Thomas H. Benton and William Smith in opposing the ratification of the treaty of 1823 with Mexico, which established a boundary-line intersecting the Red and Arkansas rivers, thus leaving only Florida and Arkansas for the expansion of slavery. While on the bench he delivered more opinions than any contemporary judge. On 5 Jan. 1836 he was appointed by President Jackson chargé d'affaires in Mexico, and on 28 December he closed the American legation. President Van Buren appointed him minister to Mexico on 15 Feb. 1839, in which post he was succeeded by Waddy Thompson in 1842. After his return he resided in Virginia.

**ELLIS, Robinson**, English classical scholar: b. Barming, Kent, 5 Sept. 1834; d. 9 Oct. 1913. He was educated at Rugby and Balliol College, Oxford, and in 1870 became professor of Latin in University College, London. From 1883 till 1893 he was university reader in Latin literature at Oxford, and in the latter year he was elected to the corpus professorship of Latin. His name is chiefly associated with the elucidation of the poems of the Roman poet Catullus. In 1867 he published a critical edition of Catullus ('Catulli Veronensis Liber') and in 1871 'The Poems and Fragments of Catullus' in the metres of the original, these works being followed by a 'Commentary on Catullus' (1876). Other publications of his include Ovid's 'Ibis,' with commentary (1881); 'Fables of Avianus' (1887); 'Ovintii Carmina' (1887); 'Noctes Manilianæ' (1891); 'The

Fables of Phædrus' (1894), and a new recension of 'Velleius Paterculus,' with commentary (1898); 'Aetna' (1900); 'Appendix Vergiliana' (1907); 'Licinianus' (1908). Consult *American Journal of Philology* (Vol. XXXIV, pp. 494-496; 1913).

**ELLIS, William Hodgson**, Canadian chemist: b. Bakewell, Derbyshire, England, 1845. He came to Canada in early youth and was graduated at the University of Toronto in 1867, afterward studying medicine there and in Great Britain. On his return he became professor of chemistry in Trinity Medical School and lecturer on chemistry at Trinity University. Afterward he became instructor in chemistry in the Provincial College of Technology, and in 1900 was appointed to the chair of toxicology in the University of Toronto. He also served as official analyst of the Inland Revenue office at Toronto. He is widely known as an expert chemist.

**ELLIS, William Thomas**, American journalist: b. Allegheny, Pa., 25 Oct. 1873. He was educated in the public schools and until 1894 was on the staff of Philadelphia newspapers, when he became editor of the *International Christian Endeavor* organ. In 1897 he became editor of *Forward* and in 1903-08 was editorial writer for the *Philadelphia Press*. He investigated social conditions in foreign countries in 1906-07 and in 1910-11 in the interest of a news syndicate. He wrote Sunday-school lessons and also contributed to religious periodicals. He has lectured frequently before religious bodies and has published 'Men and Missions' (1909) and 'Foreign Missions through a Journalist's Eyes.'

**ELLIS ISLAND**, small island situated in New York Bay, one mile southwest of the Battery, where the old immigrant station, Castle Garden, was located. The United States immigrant commissioner has his offices on this island. Immigrants detained for investigation as to compliance with the United States immigration laws are kept on this island until allowed to land or are deported. It was sold by New York State to the United States in 1808, and for many years was used as a powder magazine. In 1891 it was made an immigrant station. The present buildings were erected in 1897, when the original structures were burned.

**ELLORA**, ě-ló'rā, **ELORA**, or **ELURU**, ě-loo'rā, India, village in the province of Aurungābād Hyderābād State; situated in 20° 21' N., and 75° 10' E., about 15 miles northwest of Aurungābād city. Near by is the red stone temple of Ahalyā Bai, the Rānē of Indore (1767-95), a good example of modern Hindu architecture. Ellora is celebrated for some remarkable cave temples, excavated in the solid rock, which in magnitude and perfection surpass all other constructions of the kind in India. The temples are divided into three series, Buddhist, Brāhmanical and Jain and are arranged chronologically. There are 12 Buddhist caves at the north end, 5 Jain caves at the opposite end, with 17 Brāhmanical caves between. Important inscriptions have been found on them, dating from the 5th to the 9th centuries. The Kailās temple at Ellora is a remarkable specimen of Indian architecture. Its court is about 154 feet wide by 276 feet long,

entirely cut out of the solid rock, backed by a scarp 107 feet high. A curtain of stone has been left at the front on which forms of Siva, Vishna and the other gods are carved. Rooms inside face an entrance passage at the end of which are a colossal Lakshmi and her attendant elephant and lotuses. An inscription dates from the 8th century. A bridge leads to the temple proper, guarded by posts. The temple was built by Krishna I, the Rāshtrakūta King of Malked (760-83). Consult Fergusson and Burgess, 'The Cave Temples of India' (London 1880).

**ELLORE**, è-lōr', India, town, in the Godavari district of the Madras presidency, on the river Jammaler, once the capital of the Northern Circars. It has magisterial and judicial establishments, police station, post office, etc., a number of Christian missions and a garrison. There are some manufactures of carpets and saltpetre. Pop. 33,500.

**ELLSWORTH**, Ephraim Elmer, American soldier: b. Mechanicsville, N. Y., 23 April 1837; d. Alexandria, Va., 24 May 1861. He organized about 1859 a zouave corps which became noted for the excellence of its discipline. In March 1861 he accompanied President Lincoln to Washington, and in April he went to New York, where he organized a zouave regiment of firemen, of which he became colonel. Ordered to Alexandria, he lowered a Confederate flag floating over a hotel, for which act the hotelkeeper shot him dead.

**ELLSWORTH**, Oliver, American jurist: b. Windsor, Conn., 29 April 1745; d. there, 26 Nov. 1807. He was graduated at the College of New Jersey in 1766, and soon after commenced the practice of law. In 1777 he was chosen a delegate to the Continental Congress, and in 1780 was elected a member of the council of Connecticut, in which body he continued till 1784, when he was appointed a judge of the Superior Court. In 1787 he was elected to the convention which framed the Federal Constitution, and was afterward a member of the State convention, where he earnestly advocated the ratification of that important instrument, which his exertions had essentially aided in producing. In 1789 he was chosen a Senator of the United States, which station he filled till 1796, when he was nominated by Washington Chief Justice of the Supreme Court of the United States. In 1799 he was appointed envoy extraordinary to Paris, and with his associates successfully negotiated a treaty with the French. He resigned his office of chief justice in 1800. In 1803 he was made a member of the governor's council of Connecticut, and in 1807, chief justice of that State. His biography was written by W. G. Brown (New York 1905).

**ELLSWORTH**, Maine, city, port of entry and county-seat of Hancock County, on both sides of the Union River, and on the Maine Central Railroad; 30 miles southeast of Bangor. It is the trade centre of the county and has extensive timber, ship-building and fishing interests, exporting over 50,000,000 feet of lumber annually. It has shoe, woolen, leather, carriage, sails, gasoline engines and other manufacturing industries. The city contains a court-

house, custom-house, public library and a city hall. The Union River is crossed by several bridges and furnishes good water power for manufacturing purposes. A fish hatchery is maintained here by the Federal government. The city was settled in 1763, was incorporated as a town in 1800 and as a city in 1869. A mayor and a board of aldermen administer the affairs of the municipality which controls the water-supply system and the electric plant. Pop. 3,549.

**ELLWOOD**, Charles Abram, American sociologist: b. near Ogdensburg, N. Y., 20 Jan. 1873. He was graduated at Cornell University in 1896 and studied also at the Universities of Chicago and Berlin. For one year he was lecturer and instructor at the University of Nebraska and in 1900 became professor of sociology at the University of Missouri. He became also advisory editor of the *American Journal of Sociology* and associate editor of the *Journal of Criminal Law and Criminology*. In 1904 he served as president of the Missouri Confederated Charities. He has published 'Sociology and Modern Social Problems' (1910); 'Sociology in its Psychological Aspects' (1912; French trans., 1914); also monographs and special articles on social psychology.

**ELLWOOD**, Thomas, English Quaker: b. Crowell, near Thame, Oxfordshire, 1639; d. Amersham, 1 March 1714. About 1660 he was induced to join the Society of Friends, and subsequently became reader to Milton, with whom he improved himself in the learned languages, but was soon obliged to quit London on account of his health. In the year 1665 he procured a lodging for Milton at Chalfont, Bucks, and was the occasion of his writing 'Paradise Regained' by the following observation made on rereading the 'Paradise Lost' which the poet had lent him to read in manuscript: "Thou hast said much of paradise lost, but what hast thou to say of paradise found?" In 1705 he published the first part of 'Sacred History, or the Historical Parts of the Old Testament'; and in 1709 'Sacred History, etc., of the New Testament.' His other works are numerous; among them 'Davideis, the Life of David, King of Israel,' a poem, which is more distinguished for piety than poetry. His life, written by himself, and published the year after his death, affords many interesting particulars of the history of his sect.

**ELM**, *Ulmus*, a genus of trees and a few shrubs of the family *Ulmaceæ*. The species, of which about 20 are known, are natives of the North Temperate zone and the southern portions of the Arctic zone. Their southern limits seem to be the Himalayas in Asia and the mountains of southern Mexico. None are natives of the Pacific slope of North America. They are characterized by short-petioled, alternate, rough, usually deciduous leaves with serrate edges; axillary racemes of perfect, apetalous flowers which appear in early spring before or with the leaves; and compressed, winged, dry fruits. Many of the species are of wide economic importance. Their hard, heavy, tough, pliable wood is largely used in the manufacture of barrels, agricultural implements, boats, wagon wheels, buildings, etc., and for fuel. The inner bark of some species furnishes an article of food, and that of others a tough

**ELM TREES**

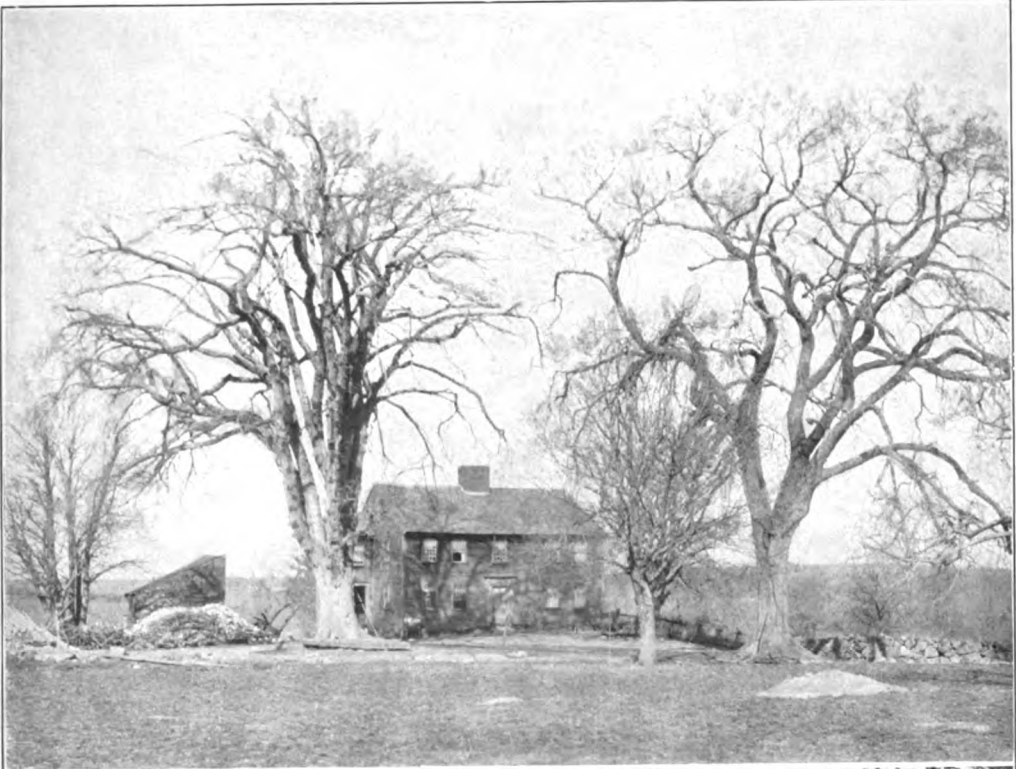

**Famous New England Elms**



bast fibre used for cordage and cloth making. The outer bark of some is used in dyeing and sugar refining. Various parts of several species were formerly popular remedies employed in medicine, but except in domestic and local practice are rarely prescribed. Most of the species are highly valued as ornamental trees in street and park planting, those specially popular being the straight-trunked, tall-growing, vase-formed species, which quickly over-arch the streets and cast an abundant shade. Many cultivated varieties of fantastic form, color of foliage, or habit of growth are also planted as curiosities.

The best-known American species is the white, water, or American elm (*U. americana*), which grows in rich moist woods, especially on the shores of streams, from Newfoundland to Florida and westward to the eastern side of the Rocky Mountains. It is a tall tree, often attaining a height of 120 feet when growing in the forest, and with a wide-spreading, less lofty top when growing in the open, where it may be seen in several different forms, popularly known as vase, plume, oak-tree, etc., according to the arrangement of the branches. Some specimens of each one develop numerous twiggy growths upon the trunk and main branches, which are thus rendered very attractive because of their feathery appearance. The most common form is the vase, in which the main branches develop at about 20 feet or more, and at their bases gradually, and toward their extremities widely diverge. This is probably the most popular street form in America. Another well-known American species is the slippery or red elm (*U. fulva*), which attains a height of 70 feet in rich soils and is found from Quebec to Florida and westward to Texas and the Dakotas. It is called red because the bud scales are reddish and conspicuous when unfolding in spring; and it is called slippery because of its mucilaginous inner bark. Its wood is less valued than that of the English elm, but more than that of the white elm. The cork or rock elm (*U. racemosa*), which grows on river banks from New England to Nebraska and as far south as Kentucky and Tennessee, attains a height of 100 feet and is noted for the corky developments resembling wings on the smaller branches. Its wood is specially valued for its great durability, strength, pliability and toughness. Another species with corky, winged branches is the wahoo or winged elm (*U. alata*), which ranges from Virginia to Florida and westward to Texas and Illinois. It rarely exceeds 70 feet in height, is very attractive in habit, and is planted for ornament in the South, but not in the North, as it is not sufficiently hardy for the rigors of winter.

The most noted European species is the English elm (*U. campestris*), which ranges through middle and southern Europe, northern Africa, and eastward to Japan. It reaches 100 feet in height and has a rather round-topped or open head, on account of its spreading branches. It is frequently planted for ornament at home and abroad, and in America is valued because its foliage continues green for several weeks after that of the white elm. It has several distinct varieties, which are sometimes considered as distinct species, and of which there are a large number of horticultural varieties. The next most important European species is probably the Scotch or wych elm (*U. scabra*),

which has much the same range as the preceding species, like which it attains a height of about 100 feet. It is a variable species with many cultivated varieties, one of the best-known of which is the Camperdown elm, which has long, pendulous branches, on account of which the tree is frequently planted as a curiosity in parks and gardens. The Chinese elm (*U. parvifolia*) is a semi-evergreen shrub or small tree, a native of eastern Asia, which has proved hardy in America as far north as Massachusetts.

Elms are readily propagated from seed which ripens in late spring or early summer and should be sown at once. The seedlings are easily managed, both as to cultivation, transplanting and pruning. The trees do best in rich soil, especially if moist. The choice varieties are generally grafted. The trees, especially of the American or white elm, are specially liable to the attacks of certain insects and diseases, which often defoliate them. The latter may be kept in check by the timely and proper application of a standard fungicide (q.v.).

The name elm is also given to various unrelated trees, the best-known of which are probably the following: Water elm (*Planera aquatica*); Spanish elm or Bois-de-Chypre (*Cordia gerascanthus*). Several Australian trees are also known as elms, especially *Duboisia myoporoides* and *Aphananthe philippinensis*, each of which is valued for its timber.

**ELM, Slippery**, in medicine, the bark of *Ulmus fulva*, is widely used as a demulcent. It is probable that the ancient Indian inhabitants of the country introduced it into medicine. Slippery elm bark is noted for the large amount of mucilage which it contains, thus rendering it a pleasing demulcent for sore throat, diarrhoea, dysentery, and inflammation of the intestinal tract in general.

**ELM-INSECTS.** Few ornamental trees are more subject to the attacks of insects than are the elms, and especially the American elm. The European species are, however, attractive to the European insects, of which many have been brought over unintentionally, and have spread remarkably because of the absence of their enemies. One of the most notable is the plant-louse known as *Colopha ulmicola*, which produces the cockscomb galls upon the foliage. It is rarely very troublesome, and has usually done its damage before it can be attacked. Kerosene emulsion, if applied in time, will prove effective. (See INSECTICIDE). A borer (*Saperda tridentata*) is sometimes troublesome, but there seems to be no satisfactory way to control it, though it has been suggested that the trunk should be washed with lime or soft soap during June and July. Most of the other insects that attack the elms are beetles, their larvæ, or the caterpillars of various moths. These all bite their food, and hence may be attacked with arsenites or other stomach poisons sprayed upon the foliage. Among these insects are the four-horned sphinx-moth (*Ceratonia amyntor* or *quadricornis*), a green caterpillar with four little horns near the head and the long anal horn characteristic of the sphinx-moth. The bag-worm (*Thyridopteryx ephemeraformis*), the gypsy-moth (*Ocneria dispar*), the tussock-moth (*Notolophus* or *Orgyia leucostigma*),

and several other general feeders are frequently troublesome. But the most important leaf-eating enemy of the elm is the elm-leaf beetle (*Galeruca xanthomelana*), a reddish-yellow, two-striped European insect which appears and eats the leaves in spring. The bottle-shaped yellow eggs are laid in rows on the under sides of the leaves, and the hairy, black-spotted, yellow larvæ eat circular holes between the leaf-veins. Spraying with arsenites is effective, but where more than one brood is produced the sprayings must be repeated frequently throughout the summer. Consult Marlatt, 'Elm Leaf Beetle,' Circular 8, Division of Entomology, United States Department of Agriculture (Washington 1895).

**ELMAN, Mischa**, Jewish violinist: b. Talnoje, Russia, 1892. He showed such remarkable talent that at the age of six he was taken by his father to Odessa and there studied under competent masters for four years. He met Leopold Auer in 1902 and so impressed the latter that he secured the permission of the Tsar for Elman's admission to the Imperial Conservatory at Saint Petersburg, hitherto closed to members of the Jewish race. Elman spent two years there under Auer and at his début in 1904 he was at once acclaimed as an artist of first rank. He toured Germany and everywhere scored a triumphant success. He visited the United States in 1908 and again in 1911, 1912, 1913 and 1914, being eminently successful on every occasion. On the violin he is now recognized as a veritable genius.

**ELMENDORF, Theresa Hubbell West**, American librarian: b. Pardeeville, Wis., 1855. She was graduated at Miss Wheelock's Seminary, Milwaukee, in 1874 and from 1880 to 1896 was deputy librarian and librarian of the Milwaukee Public Library. In 1896 she married Henry Livingston Elmendorf (d. 1906), and in 1906 was appointed vice-librarian of the Buffalo Public Library. In 1903-04 she was president of the New York Library Association and in 1911 became president of the American Library Association — the first woman to fill that office. She was also coeditor of the 'American Library Association Catalogue' and has published many articles in library periodicals on professional topics.

**ELMINA**, ɛl-mé'nā, or **SAINT GEORGE DEL MINA**, West Africa, town belonging to Great Britain, formerly the capital of the Dutch settlements on the Gold Coast, five or six miles west of Cape Coast Castle. The Castle of Saint George del Mina was the first European establishment on the coast of Guinea, having been erected by the Portuguese in 1481. The castle is the residence of the government officials of the district. It is the chief outlet for the trade of Ashanti. It came under English control in 1872, when it was claimed by the King of Ashanti the result being the Ashanti wars of 1873-74. Pop. about 4,000.

**ELMIRA**, N. Y., city, county-seat of Chemung County, on both sides of the Chemung River, and on the Delaware and Lackawanna, the Lehigh Valley, the Northern Central and the Erie railways; 100 miles southeast of Rochester, 149 miles east-southeast of Buffalo, and 46 miles south-southwest of Ithaca. Among the more important establishments are railroad-

car shops, iron and steel bridge works, steel-plate works, valve and radiator works, manufacturing of boots and shoes, automobile parts, tables, bicycles, glass, fire engines, tobacco and cigars, boilers and engines, doors, sashes and blinds, hard-wood finishing works, silk and knitting mills, tobacco warehouses, dyeworks, breweries and aluminum works. The district is fertile, and there are also stone-quarters in the vicinity. Here are located Elmira College (q.v.), a State armory, the State reformatory (see ELMIRA REFORMATORY), the Arnot-Ogden Memorial Hospital, the Steele Memorial Free Library, a Federal government building housing the Federal courts, the post office, etc., and various charitable institutions. The park system includes Wisner, Riverside, Eldridge and Hoffman parks. Elmira is finely laid out, and has an excellent water supply, and gas and electric lighting. Elmira was permanently settled in 1788, was incorporated as the village of Newtown in 1815, and in 1828 was reincorporated as the village of Elmira. In 1836 it became the county-seat of Chemung County, and in 1864 obtained its city charter. During the Civil War it was the State recruiting and military rendezvous, and in 1864-65 one of the Federal prisons for Confederate prisoners of war was here situated. Near the present site of Elmira the battle of Newtown was fought, 29 Aug. 1779. General Sullivan, with an American force numbering 5,000, defeating a combined band of Tories and Indians commanded respectively by Sir John Johnson and Joseph Brant (Thayendanegea) and numbering approximately 1,500. The battle-ground is now marked by a memorial to Sullivan. Elmira is governed, under a charter of 1906, by a mayor, who is biennially elected, and a common council, which is unicameral. In addition to the aldermen who are chosen by wards for terms of two years, the recorder, municipal judge and 12 supervisors, to act as a county board, are also chosen by popular vote. Pop. 37,816.

**ELMIRA, Battle of**, 29 Aug. 1779, in the Revolution. See CHEMUNG, BATTLE OF.

**ELMIRA COLLEGE**, at Elmira, N. Y. The first college founded exclusively for women in the United States (1855). Under the auspices of the Presbyterian Church, its course of study from the first demanded as high a grade of work as is usual in first-class colleges. The degrees conferred are bachelor of arts, bachelor of science, bachelor of music and master of arts. The college maintains a graduate department and also a summer session. The average enrolment is about 260, with 20 members in the faculty. There are 11,000 volumes in the library. The annual income is about \$90,000, and the productive funds amount to \$140,000.

**ELMIRA HEIGHTS**, N. Y., village in Chemung County, adjoining Elmira, on the Delaware, Lackawanna and Western, the Erie and the Lehigh Valley railroads. Bridgeworks, machine shops, knitting mills and pump factories give employment to a very great number. Pop. 2,732.

**ELMIRA REFORMATORY**, State institution, located in Elmira, N. Y. It is a reformatory to which may be sent only males between the ages of 16 and 30 who have not served a period in a State prison. The court

of the State of New York, in sentencing a prisoner to this institution, has no authority to limit the time; that is determined by the managers of the institution, and is almost wholly dependent upon the conduct of the prisoner. However, the term of imprisonment shall not, according to the law of the State, "exceed the maximum term provided by law for the crime for which the prisoner was convicted and sentenced." This reformatory, which takes the place of a State prison for male offenders who have not become hardened in crime, has effected a radical change in methods of dealing with the class of law-breakers intended to benefit. Although the law authorizing the institution was passed in 1866 it was not until 1876 that the institution was opened. The plan has been a splendid success and has had many imitators. About 22,000 prisoners have passed through its regimen. About 1,300 is the average detained there. Consult Winter, 'The Elmira Reformatory'; New York State Laws of 1877, sec. 2, ch. 173. Wines, 'Punishment and Reformation' (1895); and the *Yearbooks of the Reformatory*.

**ELMO, ERMO, or ERASMUS, Saint**, a martyr who suffered death at Formia, a town of ancient Italy, during the persecution under Diocletian, in 303. He is considered the patron saint of sailors, and is usually invoked by Italian sailors during a storm. His feast is kept on June 3.

**ELMO'S FIRE, Saint**, is the popular name of an electric appearance, especially in southern climates during thunderstorms, of a brush or star of light at the tops of masts, spires, or other objects. Greek superstition embodied this phenomenon in the story of Castor and Pollux.

**ELMORE, Alfred**, Irish artist: b. Clonakilty, Ireland, 18 June 1815; d. London, 24 Jan. 1881. He studied at Royal Academy, London, traveled through Europe to Rome, where he lived two years, returning to England in 1844, becoming an associate of the Royal Academy, 1845, and Royal Academician, 1856. Among his works are 'Martyrdom of Thomas à Becket' (1840), Saint Andrew's Church, Dublin; 'The Novice' (1843); 'Rienzi' (1844); 'Death of Robert, King of Naples' (1848); 'Griselda' (1850); 'Charles V at Yuste' (1856); 'Marie Antoinette in the Temple' (1861); Louis XIII and Louis XIV' (1870); 'Ophelia' (1875); 'Mary Queen of Scots and Darnley' (1877); 'Pompeii,' 'John Alden and Priscilla' (1878); 'After the Ruin,' and 'Lenore.'

**ELMWOOD PLACE**, Ohio, village of Hamilton County, adjoining Cincinnati, to which it has repeatedly refused to be annexed, and on the Cincinnati, Chicago and Saint Louis and the Dayton and Cleveland railroads, the Miami River and the Erie Canal. It contains large steel manufacturing plants and extensive railroad freight yards. Pop. 3,423.

**ELOBEY ISLANDS**, a-lo-bā'ē. The name of two small islands off the coast of Guinea, in Africa, belonging to Spain. Elobey Chico is the smaller and Elobey Grande the larger. Pop. 350.

**ELOCUTION** (Latin *elocutio*, *e*, out, *loqui*, to speak), the science and art of expression by voice and action. Though expression is depend-

ent upon the thought or emotion to be given, elocution applies only to the manner of delivery. In a larger sense it relates to all forms of expressive art, such as music, painting or sculpture; but the treatment here is confined to its uses in human action and speech. As a science it discovers and sets forth the elements or principles of expression; as an art it embodies these elements in the portrayal of our physical, mental and emotive moods.

The principles of elocution are as old as the human race and are exemplified in nature whenever the vibration of vocal cords produce sound or muscular activities reveal a psychic state. They are heard and seen in animate nature, and their proper use constitutes that naturalness so desirable in public speech. The laws governing the use of these elements are as fixed and definite as those of other well-established sciences, and a violation of these laws results in unnatural, ineffective expression. The relation between psychic conditions and the elements and laws through which impressions are received and expressed presents a useful and consistent philosophy by which all students of the art of expression in any of its forms may be guided.

Man is endowed with a vital, a mental and an emotive nature. Through these three natures he receives all impressions, and through the elements of elocution corresponding to these triune natures he must communicate all expression.

#### PART I.—ELEMENTS OF VOCAL EXPRESSION.

There are four generic vocal elements of elocution, namely, *Quality*, *Force*, *Time* and *Pitch*, all of which are embodied in every utterance, while, in turn, every shade of human expression may be traced in its various subdivisions and combinations. A tabular view of the vocal elements is given on p. 262.

**I. Quality.**—Quality is the tone-color or kind of voice, the purity or impurity of the tone, and is dependent upon the size, shape and physical condition of the vocal organs and cavities. Broadly speaking it is an emotive element which subdivides into eight varieties, each having a definite correspondence to man's triune nature. Each quality is determined by its resonance, which Helmholtz defines as "the strengthening or reinforcing of sound" in the cavities of the head, throat and chest. By changing these resonances at will the speaker can employ the qualities to express his various moods and emotions.

(1) *Normal*.—The normal is the ordinary, predominant, characteristic quality of voice peculiar to each individual. Its resonance is in the upper and back part of the mouth, and the tone should be pure. By this quality we recognize the voices of different persons. It belongs to the mental division and is the natural expression of our ordinary thoughts, such as solemnity, tranquillity, mild pathos, conversation, didactic thought, gladness, and joy.

(2) *Orotund*.—The orotund is a strong, clear, deep, voluminous quality, the resonance of which is in the upper part of the thoracic cavity. It represents about equally the mental and vital natures and is used to express thoughts and emotions of a lofty nature, such as reverence, sublimity, grandeur, courage, patriotism and oratorical intensity.

(3) *Oral*.—The oral is a thin, feeble, shallow quality with the resonance in the forward part of the mouth. It is the physical result of a low state of inherent or exerted vitality and logically belongs to the vital division. It is generally used by a speaker in a personative sense to express sickness, feebleness, idiocy, timidity and fatigue.

(4) *Nasal*.—The nasal is an impure twanging, head-tone with the resonance in the front nasal cavities. It represents a vital condition and belongs to that division. As an habitual

(6) *Guttural*.—The guttural is a harsh, grating, impure quality the resonance of which is in the upper part of the throat. It represents a vital condition under a strong emotion and belongs about equally to the vital and emotive natures. It is used to express the malignant passions such as malice, scorn, anger, revenge, violent hate and rage.

(7) *Pectoral*.—The pectoral is a hollow, hoarse, sepulchral quality with the resonance in the lower part of the chest. It is emotive in nature and is never used except under the influence of the deepest emotions such as veneration, dread, amazement or horror.

(8) *Aspirate*.—The aspirate is a hissing, breathy, whispered quality in which intensity of emotion forces out more breath than can be vocalized. It belongs to the emotive division. The resonance varies according to the position of the organs and resonant cavities; and its use ranges from the gentlest whisper of secrecy or caution to the intense, half-whispered emotions of fear, terror or consternation.

II. *Force*.—Force is the power or energy with which sound waves are sent forth from the vocal organs. Figuratively speaking, it is the exploding powder back of the projectile and clearly represents the vital nature in speech. It has three divisions.

(1) *Form*.—Form is the manner of exerting force, the smoothness or abruptness with which a sound or word is begun and ended. It reveals the sentiment or emotion implied and belongs to the emotive division. It has three divisions which also correspond to the trine nature of man.

a. *Effusive*.—The effusive is that form of voice in which the sound flows forth smoothly and evenly without abruptness of force either in the beginning or the ending of the tone. It represents the emotive nature and is used to express such gentle and solemn emotions as pathos, tranquillity, reverence, awe or suppressed fear.

b. *Expulsive*.—The expulsive is that form in which the force is applied abruptly causing the sound to rush forth from the vocal organs. It is the ordinary form and represents the mental nature in the expression of narration, didactic thought, gladness, patriotism, etc.

c. *Explosive*.—The explosive is that form in which the force is exerted very abruptly, causing the sound to burst forth from the vocal organs. It belongs to the vital nature and is used to express those emotions in which great physical vitality is aroused such as in the excitement of ecstatic joy, great earnestness, defiance, alarm, anger, etc.

(2) *Degree*.—Degree of force is the measure or power with which sounds are uttered. Its subdivisions are *subdued*, *moderate* and *energetic*, all of which correspond to the vital nature and mark the degree of energy used. This scale of degrees is relative and dependent upon individuality and the acoustic properties of the auditory which, in turn, depend upon the size and shape of the room and whether or not it is filled with an audience.

(3) *Stress*.—Stress is the application of force to the different parts of a sound or syllable. Any change of the location of the strongest impulse of force from one part of a word to another invariably changes the meaning of the utterance; hence stress responds to

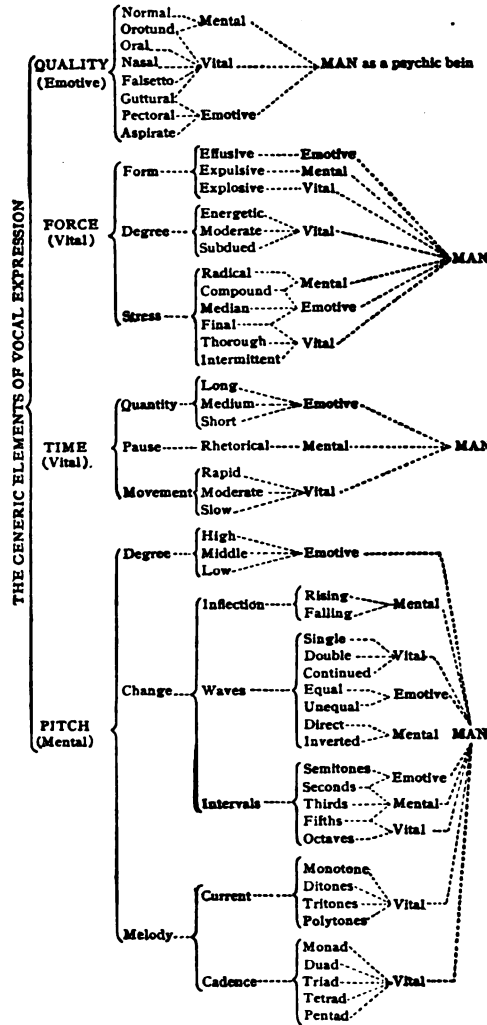

quality it is a grave defect in a speaker. Under control of the will it may be used in an impersonative way to express laziness, mockery, burlesque or drollery; and in more serious thought, it is often employed to give pungency to irony, insinuation or contempt.

(5) *Falsetto*.—The falsetto is a pure, shrill, penetrating quality ranging above the ordinary pitch. Its resonance is in the upper part of the pharynx and it belongs to the vital division. Its use shows a lack of physical poise and expresses great excitement, fright, yelling, screaming, calling, etc.



the mental division of man's triune nature. There are six varieties of stress.

a. **Radical.**—In the radical stress the force is applied strongest in the first part of the sound. It is the ordinary stress representing the mental nature and is expressive of didactic thought, narration, gaiety, patriotism, courage, etc.

b. **Compound.**—In the compound stress the main force is put upon the first and the last parts of the sound. It represents the mental and emotive natures and expresses any irony of purpose or insinuation of statement such as mockery, satire, sarcasm, taunt, derision, etc.

c. **Median.**—Median stress represents the placing of the force chiefly upon the middle part of the sound. It belongs to the emotive division and is used to express pathos, sorrow, wailing, reverence, awe, etc.

d. **Final.**—In the final stress the force is placed mainly upon the last part of the sound. It represents the emotive and vital natures and expresses self-assertion, determination, stubbornness, courage, amazement, hate or revenge.

e. **Thorough.**—The force continues in about the same intensity throughout the sound in the thorough stress which represents the vital nature and is appropriate in the expression of calling, command, triumph, shouting, apostrophe, lofty appeal, etc.

f. **Intermittent.**—In the intermittent stress the force is placed upon periodic parts of the sound which represents a physical unsteadiness or trembling of the body; hence it belongs to the vital division. It is used to express laughter, crying, ecstatic joy, deep sorrow, tenderness, sympathy, extreme fright and defiant courage.

**III. Time.**—Time is the duration of utterance and relates to the length of vocal sounds, syllables and words, the rests which occur between them and the rate of speed with which they are given. It is one of the vital generic elements with three specific divisions which represent the three psychic natures.

(1) **Pause.**—Pause is the time spent between the impulses of the voice in the utterance of sounds and syllables or between words or groups of words in speech. By correct pausing words are grouped into their ideas, hence this element belongs to the mental division of the triune nature. Rhetorical pauses should be used (a) *Before* relative pronouns always and conjunctive words, prepositional phrases and infinitive phrases generally; (b) *between* words of a series, words marking an ellipsis and clauses; (c) *after* nominative phrases, words or phrases used independently and words of strong emphasis or emotion; (d) *before and after* words or phrases transposed or used in apposition, direct quotations and parenthetical expressions.

(2) **Quantity.**—Quantity is the length of time given to the utterance of sounds, words and syllables. It is especially adapted to the vocal utterance of the different shades of feeling or emotion and belongs to the emotive division. It naturally divides into (a) *long quantity* which expresses sorrow, pathos, reverence, sublimity, apostrophe, command, calling, etc.; (b) *medium quantity* which is ordinarily used to express narrative, descriptive and didactic thought and all unemphatic words of unemotive language; and (c) *short quantity*

which is the shortest prolongation of sound consistent with the requirements of articulation and is expressive of joy, laughter, impatience, contempt, fright, excited anticipation, etc.

The use of the various lengths of quantity depends upon the length of the inherent phonetic sounds composing the words. Long quantity, especially, should never be placed on a short sound.

(3) **Movement.**—This is the rate or degree of rapidity with which a series of sounds or words or a sentence is given. Since the various degrees of movement are but an expression of the physical activities of speech this element belongs to the vital division of man's triune nature. Its degrees are *slow*, *moderate* and *rapid*, and are dependent upon the individuality of the speaker and the acoustic conditions. Very naturally the inner or reflective life requires a slow utterance, while the impulsive, lively, joyous moods find their expression in rapid movement, and the ordinary states of mind require the moderate degrees.

**IV. Pitch.**—Pitch is the range or compass of voice and relates to the location, variation and succession of notes upon the scale of degrees. It has three specific divisions which may be subdivided to suit greater varieties of shading in expression. Broadly speaking, it is mental in significance and belongs to that triune division.

(1) **Degree.**—The degree of pitch is the range of voice from the lowest to the highest tone, and the position in that range given to a particular note or word. Its subdivisions are *high*, *middle* and *low*, which may be further subdivided; and like all other scales of degrees in elocution depends upon individuality and acoustic conditions. The degrees of pitch mark plainly the speaker's emotive state, and the scale ranges from the deeply serious of reverential emotions of low pitch, through the ordinary thought of middle to the cry of excitement, joy, alarm or defiance of high pitch.

(2) **Change.**—Change is the transition from one degree of pitch to another and is accomplished by a concrete glide or a discrete step. By changes of pitch we convey the various shading of meaning in expression and thus represent the mental nature. There are three varieties of change or transition which correspond to the triune classification.

a. **Inflection.**—Which corresponds to the mental nature is a simple concrete change of pitch of which there are two varieties, *rising*, expressing anticipation or questioning, and *falling*, which denotes decision and conclusion.

b. **Waves.**—Waves are emotive and consist of two or more inflections united in a continuous concrete movement. They may be *single*, composed of two inflections; *double*, composed of three; or *continued*, made up of four or more inflections, all of which are used to extend the vocal quantity without overstepping the interval of pitch that the sentiment requires; and they represent the vital nature. Waves are also *equal*, expressing pleasantry; or *unequal*, implying irony; both of which represent the emotive; and *direct*, expressing assertion, and *inverted*, indicating anticipation, both of which are representative of the mental nature.

c. **Intervals.**—An interval is the distance between two points on the scale and marks the

length of the vocal slide or step taken. As a measure of the physical act of vocalization it belongs to the vital division. The five relative intervals of pitch are: *Semitones*, expressing plaintiveness or sorrow; *seconds*, reverence and sublimity; *thirds*, ordinary conversation and oratorical thought; *fifths*, animated conversation and triumph; and *octaves* representing extreme surprise, horror or impassioned exclamation.

(3) *Melody*.—Melody is the succession of speech-notes in utterance and represents the vital nature in the vocal placing of all degrees and changes of pitch upon the scale. There are two divisions.

a. Current melody relates to the body of the sentence and is made up of *monotones*, *ditones*, *tritones* and *polytones*, all of which show the vital notation of intervals and notes and record the vocal trend in speech or song.

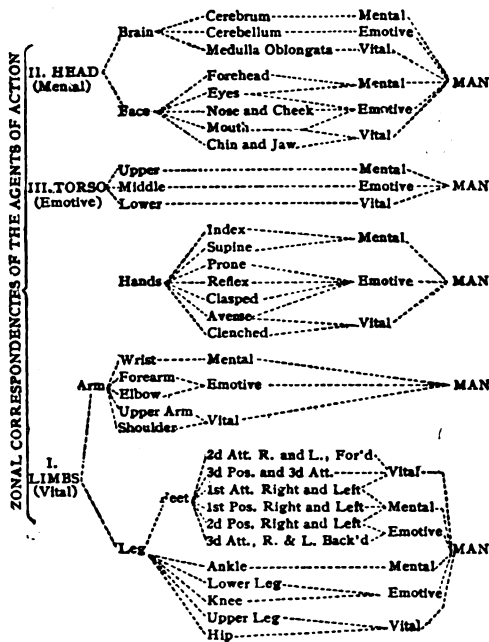

b. The cadence, which is that part of melody which gives repose at the close of a sentence when the thought is complete. Its technical varieties are (a) the *monad*, in which the lowering of pitch occurs on one syllable; (b) the *first and second duads*, on two syllables; (c) the *rising and falling triads*, on three syllables; (d) the *tetrad*, on four; and (e) the *pentad*, on five syllables.

The distance over which the line of repose is reached is dependent upon the range of the current melody.

PART II.—THE PRINCIPLES OF ACTION.

Action in elocution is that part of delivery which addresses itself to the eye. The main principles of gesture and position, the common property of students of expression since the days of the ancient Greeks, were set forth in the 'Chironomia,' a voluminous work of a century ago, by Dr. Gilbert Austin, of London; but the eminent French psychologist, François Delsarte, was the first to show the relation of

the whole physical activities to man's triune nature and present anything like a philosophy of actional expression. More recent writers have presented the subject in textual form and made it practical for the student. Combining the expressional use of the hands and feet, as explained in the 'Chironomia,' with the zonal correspondencies of Delsarte, we dismiss the subject by referring to the diagram.

For the history of elocution and its relation to the material used in speaking, see ORATORY.

**Bibliography.**—Bartlett, B. R., 'The Practical Reader' (New York 1822); Bassett, 'A Handbook of Oral Reading' (Boston 1917); Belle, A. M., 'Essays and Postscripts on Elocution' (New York 1886); Brewer, J. M., 'Oral English' (Boston 1916); Burgh, J., 'The Art of Speaking' (New York 1785); Fulton, R. I., 'Practical Elements of Elocution' (Boston 1883); Jennings, H., 'Voice and its Natural Development' (New York 1911); Kliser, G., 'How to Develop Power and Personality' (New York 1909); 'How to Read and Declaim' (New York 1911); 'How to Speak in Public' (New York 1906); Knowles, A., 'Oral English' (Boston 1916); Pertwee, E., 'The Art of Effective Public Speaking' (New York 1911); Porter, E., 'Rhetorical Reader' (New York 1835); Rush, J., 'The Philosophy of the Human Voice' (Philadelphia 1885); Sheridan, T., 'A Course of Lectures on Elocution' (Troy 1803); Staley, D. M., 'Psychology of the Spoken Word' (Boston 1914); Winans, J. A., 'Public Speaking' (New York 1916). Among the organs devoted to elocution is *The Quarterly Journal of Public Speaking* (official organ of Society of Teachers of Elocution, published at Menasha, Wis.).

**ELOHIM**, ʔl'ō-hīm or ʔ-lō'hīm (plural of Eloah), one of the Hebrew names for God, of frequent occurrence in the Bible, especially in those parts of the Pentateuch attributed to the earliest writers in the northern domain of the Semitic race. Elohim is used in speaking both of the true God and of false gods, while Jehovah is confined to the true God. The plural form of Elohim (literally signifying "the great Eloah" or God) has caused a good deal of controversy among critics. By some it has been considered as containing an allusion to the doctrine of the Trinity, others regard it as the plural of excellence, while others hold it as establishing the fact of a primitive polytheism. This word, together with "Jehovah," has played a great part in modern criticism. Critics have professed to find in the comparative frequency of the two terms an evidence of the date of the manuscripts in which they occur; but on this controversy we cannot enter. See ELOHIST.

**ELOHIST**, ʔl'ō-hīst, also called **Yahwist**, both used in contradistinction to Jehovist (q.v.), one of the biblical writers, hypothetically assumed to have written part of the Pentateuch, who habitually, if not exclusively, used the Hebrew name Elohim for God. The Elohist passages in the Old Testament, as determined upon by biblical scholars, are simple, straightforward, and bear no signs of rhetoric or poetic effort, therein contrasting with the Jehovistic paragraphs. Gen. i, 27 is Elohist; Gen. ii, 21-4 is Jehovistic.

**ELOISE**, ɛl'ō-ɛz, Mich., a hospital settlement in Wayne County, on the Michigan Central Railroad, 15 miles from Detroit. Here are situated a large hospital, an infirmary and a sanitarium. These are controlled by the Wayne County Superintendent of the Poor, a board established in 1832. Pop. 1,750.

**ELON COLLEGE**, a coeducational institution, situated at Elon College, 64 miles north of Raleigh, N. C. It was founded under the auspices of the Christian Church, in 1889, succeeding the Graham Normal College, founded in 1865. Courses are given leading to the degrees of bachelor of arts, music, philosophy and literature; and master of arts. The advanced degrees of doctors of literature, divinity and laws are also awarded. Certificates are given in music, art, expression and domestic science. The instructors number 27, the students 400. The library contains 10,000 volumes.

**ELONGATION**, in astronomy, the angle that measures the apparent distance of two stars as seen from the earth. The term is, however, by usage confined exclusively to the distance of a planet from the sun, and of a satellite from its primary. The greatest elongation of Mercury amounts to about 28 degrees 30 minutes; that of Venus to about 47 degrees 48 minutes, and that of the superior planets may have any value up to 180 degrees. When two fixed stars or planets are spoken of the word "distance" is employed.

**ELOPEMENT**, in law, an act of unlicensed departure, especially when a wife forsakes her husband and flees with a paramour, or when a daughter or ward accepting the protection of a lover leaves her natural or legal guardians. In almost every one of the States, the male principal in an elopement is held guilty of an abduction provided his associate in the act is under age. Marriage, however, checks all consequent criminal proceedings unless the female alleges coercion. All persons guilty of aiding or abetting an elopement of a male with a female are deemed in law accessories, and liable to legal proceedings. Elopers themselves are not safe from arrest, their act coming within the purview of the criminal statutes.

**ELOTHERIUM**, an extinct suilline animal of the Lower Miocene Epoch, remotely related to the hippopotami and pigs. The skull suggests that of the hippopotamus, but it has a narrow elongated muzzle; and the front teeth resemble those of the carnivora rather than the shearing tusks of the hippopotami and pigs. The limbs and feet are tall and stilted, the lateral toes reduced to small rudiments, as in ruminants. Different species ranged in size from that of a sheep to that of a rhinoceros.

**ELPHINSTONE**, Mountstuart, East Indian administrator: b. Scotland, 6 Oct. 1779; d. Limpsfield, Surrey, 20 Nov. 1859. He joined the Bengal civil service in 1795; was Ambassador to the Afghan court in 1808; resident at the court of Poonah from 1810 to 1817; and British commissioner to that province from 1817 to 1819, when he became lieutenant-governor of Bombay. During a government of seven years he established a code of laws, lightened taxes and paid great attention to schools and public institutions. He resigned in 1827. A college

established by the natives was called after him Elphinstone College. He twice declined the governor-generalship of India and devoted the remainder of his life to literary pursuits. He was the author of an 'Account of the Kingdom of Cabul and Its Dependencies' (1815); and a 'History of India' (1841).

**ELPHINSTONE**, William, Scottish prelate: b. Glasgow 1431; d. 25 Oct. 1514. Having gone to France he studied law for three years, and was appointed professor of law, first at Paris and subsequently at Orleans. He was later made general of the diocese of Glasgow (1471); rector of that university (1474); archdeacon of Lismore (1478), and commissary of the Lothians, and in 1479 became archdeacon of Argyle, and Privy Councillor. Soon after he was made bishop of Ross; and in 1483 was transferred to the see of Aberdeen. In 1488 he was appointed Lord High Chancellor of the kingdom. In October of that year he assisted in the coronation of James IV. He was afterward sent on a mission to Germany, and on his return was installed in the office of Keeper of the Privy Seal, which he held till his death. In 1494 he obtained a papal bull for the erection of a university at Aberdeen, and King's College and University soon came into existence. He was the author of 'Breviarium Aberdonense' (1509-10, reprinted London 1850).

**ELSBERG**, ɛlz'bɛrg, Louis, American physician: b. Gerlohn, Prussia, 1836; d. in the United States in 1885. His family settled in the United States in 1849 at Philadelphia. He introduced the art of laryngoscopy in the United States, wrote many papers on the throat and its diseases, notably, 'The Throat and the Production of the Voice'; was the first to illustrate the character of undertones and divisions of sound in articulation, and invented many instruments which are used in surgical treatment of the throat and ear.

**ELSHEIMER**, ɛlz'him-er, Adam, German painter: b. Frankfort-on-the-Main 1578; d. probably at Rome 1620, called the "Roman Painter of Germany." He studied in Rome and settled there while still very young. He painted many biblical and mythological scenes and was a master of landscape, being the chief German artist of the end of the 16th century to acclimatize Roman art in Germany. Among his principal works are 'Jupiter and Mercury with Philemon and Baucis'; 'Joseph in the Pit'; and 'Judith' (at Dresden); 'Martyrdom of Saint Lawrence,' and 'Flight into Egypt' (Munich); his portrait and 'Triumph of Psyche' (Florence); many landscapes at Naples, Venice and Madrid; 'Good Samaritan,' and another 'Flight into Egypt' (Louvre) and a large collection of drawings.

**ELSIE VENNER**, the first novel of Oliver Wendell Holmes, was originally published as 'The Professor's Story' in the *Atlantic Monthly* for 1860, where it followed 'The Professor at the Breakfast Table.' The story centres about a young woman whose nature has a strange element not human, which she acquired before birth when her mother was bitten by a rattlesnake. The author aims to enforce his ideas regarding heredity, and especially regarding heredity as modifying moral responsibility

— ideas which he had advanced in the 'Autocrat' and the 'Professor at the Breakfast Table,' and which had been vigorously challenged by orthodox New Englanders. His moralizing is not, however, obtrusive, and his strange heroine is fascinating and not in the least repulsive. As in all Dr. Holmes' novels, the plot is of the old-fashioned, obvious sort, and some of the incidents are almost melodramatic. The humorous and realistic picture of New England village life, and of a young ladies' boarding school are delightful, and some of the more serious scenes are portrayed with force. The work has the limitations that might be expected from an author who began to write fiction at the age of 50, and who was by nature an essayist and a social philosopher rather than a novelist; but the conception is striking, and the execution not unworthy. The story has a strange power of impressing itself on the reader and is usually remembered longer than many novels of far greater technical merit.

WILLIAM B. CAIRNS.

**ELSNORE**, ɛl-sj-nōr', or **ELSINEUR** (Danish, Helsingør), Denmark, seaport, on the island of Zealand, 24 miles northeast of Copenhagen. The town has a charming site, with several interesting buildings, notably the town hall and the hospital. Its inhabitants are engaged chiefly in commerce and seafaring. The castle of Kronborg, built about 1580, is the chief defense of the town. It is a Gothic-Byzantine edifice, built by Frederick II in the boldest style, and is said to be one of the finest structures of its kind in Europe. Until 1857 tolls were exacted of all ships navigating the strait. Scenes in Shakespeare's 'Hamlet' are laid here. It is now chiefly used as a prison, and was the place of confinement of the unfortunate Matilda, sister of George III of England. The manufactures are chiefly fishing-nets and a coarse cloth, iron founding, shipbuilding, marine engines and net weaving. It has a good harbor, with excellent dry-docking facilities for repairing vessels. Coal is imported in great quantities. To the northwest lies the bathing place of Marienlyst, once a royal summer residence. Pop. 13,783.

**ELSON, Arthur**, American musical critic: b. Boston, 18 Nov. 1873. Son of Louis C. Elson (q.v.). He studied music with his father and with Prof. J. K. Paine, at Harvard. He has degrees from Harvard and the Massachusetts Institute of Technology, and has been prominent as a teacher. His chief works are 'A Critical History of Opera' (1901); 'Orchestral Instruments and their Use' (1902); 'Woman's Work in Music' (1903); 'Modern Composers of Europe' (1904); 'Musical Club Programmes from all Nations' (1907); 'The Book of Musical Knowledge' (1915); and 'The Pioneer School Music Course' (1916). He is editor-in-chief of the 'Musician's Guide' (10 vols., 1913) and author of many musical essays. He contributes occasional concert reviews to Boston *Advertiser* and many articles to magazines.

**ELSON, Henry William**, American author: b. Muskingum County, Ohio, 29 March 1857; spent early life on farm; took classical college course at Thiel College, Greenville, Pa., after which he spent three years in the Lutheran Theological Seminary at Philadelphia and later

two years in the University of Pennsylvania. After six years in Lutheran pastorates, at Kittanning and Philadelphia, Pa., he left the active ministry and took up the work of writer on historical subjects and lecturer in the University Extension Society of Philadelphia. In 1912 Dr. Elson was elected a member of the Constitutional Convention of Ohio in which he took a very active part in the debates and proceedings, especially as champion of the short ballot and as one of the leaders in bringing about a reform in the judicial system of the State. He introduced and piloted through the proposal to enable three-fourths of a jury to render a verdict in civil cases. This was made a part of the constitution of the State. Since 1905 Dr. Elson has been the head of the history department in Ohio University at Athens, Ohio. He was president of the Ohio Valley Historical Association in 1915-16.

He published 'Side Lights on American History' (2 vols., 1898-99); 'History of the United States' (1 vol., 1904); 'History of the United States' (5 vols., 1906); 'Guide to American History'; 'Guide to English History' (1906-07); wrote most of the first four volumes of the 10-volume set of the 'Photographic History of the Civil War' (1911).

**ELSON, Louis Charles**, American writer on music: b. Boston, Mass., 17 April 1848. After studying music at Leipzig he returned to Boston and has been a teacher and lecturer on music there from 1880. He has been musical editor of the Boston *Advertiser* since 1888. He has published 'Curiosities of Music' (1883); 'German Songs and Song Writers' (1886); 'Our National Music and Its Sources' (1896); 'Theory of Music' (1890); 'Realm of Music' (1892); 'European Reminiscences' (1893); 'Great Composers' (1897); 'Shakespeare in Music' (1900); 'Famous Composers and Their Works,' new series (1901). His later activities have been wide-spread. He has twice been a Lowell Institute lecturer, giving one course of eight and one of 10 lectures before that institution. He has been city lecturer of Boston, giving about 250 lectures on music to the general public of that city, assisted by an orchestra, and he has traveled over the United States and Canada with musical lectures. His 'Shakespeare in Music,' and 'Great Composers' have been reprinted in London. He has written a 'History of American Music' (1905) and a revised edition of the same (1915); 'Mistakes and Disputed Points of Music' (1912); and he is editor-in-chief of 'The University Musical Encyclopedia' (10 vols.). He has written two musical dictionaries, numerous magazine articles, and is teacher of the advanced courses in theory of music at the New England Conservatory of Music, Boston.

**ELSSLER, ɛlz'ler, Fanny**, Austrian dancer: b. Vienna, 23 June 1810; d. there, 27 Nov. 1884. She was the daughter of Johann Elssler, Haydn's factotum, and was educated at Naples for the ballet, with her elder sister Theresa (b. 1808; d. 1878), who in 1851 became the morganatic wife of Prince Adalbert of Prussia and was ennobled. Fanny Elssler during her visit to the United States gave an entertainment in order to raise money for the Bunker Hill Monument. She retired in 1851.

**ELSTER**, ɛl'stɛr, two German rivers. (1) The White, or Great Elster, rising in the west of Bohemia, flows north into Saxony, receives the Pleisse and Parde at Leipzig, and joins the Saale between Halle and Merseburg, after a course of about 115 miles. It is navigable for small vessels as far as Leipzig. (2) The Black Elster, rising in Saxony, flows north into Prussia, then northwest, receives the Pulsnitz and Röder, and joins the Elbe between Wittenberg and Torgau, after a course of about 130 miles. It is navigable for 40 miles.

**ELSTRACKE**, Reginald or Ronald, English engraver: b. probably in London and lived there early in the 17th century. His plates were made with the graver solely, their chief value being historical. He executed portraits of Mary Queen of Scots, Darnley and Queen Elizabeth. Among his works was a volume of 32 plates called 'Basiliologia: a Book of Kings, being the true and lively effigies of all our English Kings from the Conquest until this present' (1618).

**ELSWICK**, ɛlz'wɪk, England, suburb of Newcastle, containing the great ordnance works of Sir William Armstrong, Mitchell and Company. These works are probably the largest of their kind in Europe, employing in normal times about 14,000 persons. Pop. 58,352.

**ELTON**, Charles Isaac, English jurist and archaeologist: b. Somerset 1839; d. Chard, Somerset, 23 April 1900. He was educated at Oxford and was called to the bar in 1865. He represented West Somerset in Parliament as a Conservative 1884-85 and 1886-92. On legal subjects he published 'Tenures of Kent' (1867); 'Commons and Waste Lands' (1868); 'Copyholds and Customary Tenures' (1874-93); 'Improvement of Commons Bill' (1876); 'Custom and Tenant-Right' (1882); and 'Robinson on Gavelkind' (1897). Other works of his are 'Norway, The Road and Fell' (1864); 'The Career of Columbus' (1892); 'The Great Book-Collectors' (1893); and 'Shelley's Visits to France' (1894). His greatest work, however, is his 'Origins of English History' (1882). It is chiefly characterized by its thorough investigation of the evidence furnished by Greek and Roman writers regarding the condition and circumstances of early Britain, by its discussion of the ethnology and prehistoric archaeology of the country, and by the importance assigned to the Celtic and even pre-Celtic element in forming the English nation.

**ELTON**, James Frederick, English explorer: b. 3 Aug. 1840; d. 13 Dec. 1877. He entered the Indian army in 1857. In 1871 he found himself in the Transvaal and Natal; in 1873 he was vice-consul at Zanzibar, two years afterward as consul in Mozambique he explored the coast of East Africa for the sake of repressing the slave trade. With Cotterill he reached Lake Nyassa in 1877 and scaled the Konde range of mountains at the north end of the lake, to the height of 10,000 feet. After his death Cotterill published his journal under the title 'Travels and Researches among the Lakes and Mountains of Eastern and Central Africa' (1879).

**ELTON**, Oliver, English literary historian: b. 1861. He was educated at Marlborough School and at Corpus Christi College, Oxford. From 1890 to 1900 he was lecturer on English

literature at Owens College, Manchester, and in the latter year became professor of English literature at the University of Liverpool. He published an edition of Milton's 'Comus and other Poems'; 'The Mythical Books of Saxo Grammaticus,' 'Historia Danica,' translated for the Folklore Society; 'The Augustan Ages' (in 'Periods of European Literature,' 1899); 'Michael Drayton' (1906); 'Life, Letters and Writings of Frederick York Powell' (1906); 'Modern Studies' (1907); 'Survey of English Literature from 1780 to 1830' (1912); contributions and reviews in the *Manchester Guardian*, the *Quarterly Review*, etc.

**ELTON**, a shallow lake in the government of Astrakhan, in Russia; area, 60 square miles. Eight salt-water streams flow into this lake, and it has no visible outlet; thus a large salt deposit rests on the bed of the lake. From about the middle of the 17th century for 100 years, the salt from this lake was in demand; but since the opening of the salt fields in the southern part of Russia (1860) the Elton salt has not been on the market.

**ELTZBACHER**, ɛlts'bah-ɛr, Paul, German jurist: b. 1868. He was educated at the universities of Heidelberg, Leipzig, Strassburg and Göttingen. He was appointed a judge; in 1900 privatdozent at Halle, and in 1906 professor of law at the Berlin Handelshochschule. He has published 'Ueber Rechtsbegriffe' (1900); 'Die Handlungsfähigkeit' (1903); 'Die Unterlassungsklage' (1906); 'Gross-berliner Mietsverträge' (1913). His best-known work is 'Anarchismus' (1900; Eng. trans. by Byington, 1908), the most complete and unbiased treatment of the subject; it has appeared in most modern languages. The article in 'Handbuch der Politik' on anarchism was written by Eltzbacher in 1910.

**ELVAS**, ɛl'väs (Rom., Alpessa; Moorish, Balesh), Portugal, the strongest fortified city of the republic, in the province of Alemtejo, near the Spanish frontier, 10 miles west of Badajoz. Standing on a hill, it is defended by seven large bastions and two isolated forts. The city contains a 15th century cathedral, in which are housed some fine paintings; a theatre, hospital and an ancient aqueduct of remarkable construction. It was completed in 1622. Fire arms and jewelry are the only articles manufactured. The Moors fortified the place and the city suffered from the wars between the Moors, Portuguese and Spaniards. It fell to Portugal in 1226, was taken by the French in 1808, but was ceded to Portugal after the Convention of Cintra. Pop. 14,018.

**ELVES** (O. Eng., ɛlf; Germ. Alp; phantom, spirit), imaginary creatures of the northern mythology, forming, according to some classifications, with the undines, salamanders and gnomes, groups of elementary sprites identified respectively with the water, fire, earth and air. The elves are of the air, and have been more widely received in the faith and poetry of Europe under this name than under that of sylphs, invented by Paracelsus. They are capricious spirits, of diminutive size but preternatural power. Their stature is less than the size of a young girl's thumb, yet their limbs are most delicately formed, and when they will they can hurl granite blocks, bind the strongest man or shake a house. They are divided in the sagas

into good and bad, or light and dark elves, the former having eyes like the stars, countenances brighter than the sun, and golden yellow hair, the latter being blacker than pitch, and fearfully dangerous. The elves ordinarily wear glass shoes, and a cap with a little bell hanging from it. Whoever finds one of these slippers or bells may obtain from the elf who has lost it any thing which he asks for. In the winter they retire to the depths of mountains, where they live in much the same way as men, and in the first days of spring issue from their grottoes, run along the sides of hills, and swing upon the branches of the trees. In the morning they sleep in blossoms or watch the people who pass by, but at the evening twilight they meet together in the fields, join hands and sing and dance by the light of the moon. They are generally invisible, but children born on Sunday can see them, and the elves may extend the privilege to whomsoever they please. In England and Scotland they became fairies in the former, and brownies in the latter country, and were subject to a king and queen. The islands of Stern and Rugen, in the Baltic, are especially subject to the king of the elves, who rides in a chariot drawn by four black horses, and whose passage from island to island is recognized by the neighing of the steeds, the blackness of the water, and the bustle of the great aerial company who follow in his train. The elves sometimes become domestic servants, and would be valuable as such if they were less easily offended and less dangerous after taking offense. As long as their caprices are gratified, their food and drink regularly left at an appointed place, and no attempt made to interfere with their freedom, the furniture is sure to be dusted, the floor to be swept and every chamber to be perfectly in order. But the brothers Grimm, in their 'Deutsche Sagen,' have chronicled the misfortunes of many a young girl, who, having called an elf to her aid, repented too late of having offended it.

**ELVIRA COUNCIL OR SYNOD.** This council was held at Illiberis or Elvira in Granada, Spain, at the beginning of the 4th century. Three dates are assigned, May 15, 303, 305, 309. Felix, bishop of Accis, presided. The town is no longer in existence. The council was attended by 19 bishops and 26 priests. Hosius of Cordova, adviser of the Emperor Constantine, was the most important personage present. Eighty-one canons were adopted, which reveal the fact that the Spanish Church was largely influenced at the time by Noratian and Montanist teaching. The regulations are many of them very stringent and are largely negative in character. They deal with idolatry, marriage, unchastity, penance and the prohibition of communion to specified classes.

**ELWELL, Frank Edwin,** American sculptor: b. Concord, Mass., 15 June 1858. His early instruction in art was from May Alcott and Daniel C. French. He studied subsequently at the School of Fine Arts, Paris, the Ghent Academy, and with Falguière of Paris. He settled in New York soon after his return home in 1885. His principal works are 'Death and Strength' at Edam, Holland; 'Diana and the Lion,' now in the Chicago Art Institute; statue of General Hancock at Gettysburg battlefield; 'New Life,' in the cemetery of Lowell,

Mass.; monument to Edwin Booth, Cambridge, Mass.; 'Charles Dickens and Little Nell,' at Philadelphia; statues of Greece and Rome on the New Customs House, New York; busts in the Senate, Washington, D. C.; 'Water Boy of Pompey,' in the New York Metropolitan Museum. From 1902 to 1905 he was curator of a department at the Metropolitan Museum and in 1910 was chosen director of the School of Applied Design for Women, New York.

**ELWOOD,** Ind., city in Madison County, on the Pittsburgh, Cincinnati, Chicago and Saint Louis and the Lake Erie and Western railroads, about 50 miles northeast of Indianapolis. It is surrounded by an agricultural region and is in a natural-gas belt. Its industries are chiefly lumber, flour, tin-plate mills, window, iron works, saw and planing mills, brickyards, canneries, plate glass and lamp chimney and other factories. The United States census of manufactures for 1914 showed within the city limits 40 industrial establishments of factory grade, employing 2,216 persons, 1,969 being wage earners, receiving annually \$1,484,000 in wages. The capital invested aggregated \$4,624,000, and the year's output was valued at \$8,199,000; of this, \$2,507,000 was the value added by manufacture. Its shipping trade consists in the agricultural products of the surrounding country and the articles manufactured in the city. The city maintains a public library. Pop. 12,000.

**ELY, Richard Theodore,** American political economist: b. Ripley, N. Y., 13 April 1854. He was educated at Columbia College (A.B. 1876, A.M. 1879, Fellow in Letters, 1876-79), and studied at the universities of Halle, Heidelberg (Ph.D. 1879) and Geneva; Royal Statistical Bureau, Berlin, 1879-80; LL.D. Hobart College, 1892. He was head of the department of political economy at Johns Hopkins, 1881-92, when he became professor of political economy in the University of Wisconsin. He was member of the Baltimore Tax Commission, 1885-86; of the Maryland Tax Commission, 1886-88, and founded the American Bureau of Industrial Research in 1904 and has since been one of its directors. He was one of the founders of the American Economic Association, 1885; its secretary, 1885-92; its twice elected president, 1899-1901, and was first president of the American Association for Labor Legislation, 1907-08. In 1913 he was appointed lecturer at the London University; has traveled in Great Britain and Ireland and Germany investigating land problems; was invited in 1914 by the New Zealand government to visit New Zealand; member of the International Statistical Institute. He published 'French and German Socialism in Modern Times' (1883); 'Taxation in American States and Cities' (1888); 'Outlines of Economics' (1893); 'Monopolies and Trusts' (1893); 'Socialism and Social Reform' (1894); 'Studies in the Evolution of Industrial Society' (1903); 'Property and Contract in their Relation to the Distribution of Wealth' (1914); editor of 'Macmillan's Citizen's Library of Economics, Politics and Sociology,' also 'Macmillan's Social Science Text-books.'

**ELY, Theodore Newel,** American civil engineer: b. Watertown, N. Y., 23 June 1846. He was graduated at the Rensselaer Polytechnic Institute in 1866. From 1868 to 1910

he was a member of the engineering department of the Pennsylvania Railroad. He also held directorships in the Pennsylvania Steel Company and the Cambria Steel Company; was trustee of the Drexel Institute and director of the Philadelphia Academy of Fine Arts. He is honorary member of the American Institute of Architects and vice-president of the American Academy in Rome. In 1904 he was president of the Eastern Railroad Association.

**ELY**, England, an episcopal city in the county of Cambridge, about 15 miles northeast of Cambridge, on the Ouse. The place is noted for its cathedral, one of the most remarkable edifices of the kind in England. It was founded in 1083 and displays in itself all the styles of architecture from early Norman to late Perpendicular. It is a cruciform building, 537 feet long and 190 feet across the transepts. The nave is 208 feet long and the tower 215 feet high. It occupies the site of a monastery founded about the year 673 by Saint Etheldreda (or Audry), daughter of Anna, king of East Anglia. Its ancient history is most interesting. In 1071, Hereward, the noted English outlaw, defended Ely against the Normans. (See **HEREWARD**). Market gardening and fruit preserving are among the important industries. Pop. 7,917. Consult Van Rensselaer, 'English Cathedrals'; Bond, F., 'English Cathedrals'; Stewart, 'Architectural History of Ely Cathedral.'

**ELY**, Minn., city and summer resort in Saint Louis County, 115 miles northeast of Duluth, on the Duluth and Iron Range Railroad. It is in the centre of the Vermilion Iron Range, and nearby are several lakes and waterfalls. There is a large trade in fish, furs, lumber and iron. The government is vested in a mayor, elected annually, and a board of aldermen. The city has a fine high-school building and city hall, and owns the waterworks and electric-lighting plants. Pop. 3,572.

**ELY**, Isle of, a district in England, in the county of Cambridge, separated on the south by the Ouse from the remaining portion of the county and forming in itself an administrative county; area, 283,073 acres. It rests about 100 feet above the general level of the fen country, and was formerly surrounded by marshes, which at times became sheets of water. The whole has by drainage been converted into fertile fields and is a most productive fruit-growing district. Pop. 69,752.

**ELYMAS**. See **BAR-JESUS**.

**ELYOT**, ɛl'j-ot, **SIR THOMAS**, English author: b. Wiltshire not later than 1490; d. Carlton, Cambridgeshire, 20 March 1546. In 1511 he became clerk of assize, in 1523 clerk of the king's council. In 1531-32, as Ambassador to Charles V, he visited the Low Countries and Germany, having orders to procure, if possible, the arrest of Tyndale. 'The Boke named the Governour, devised by Sir Thomas Elyot, Knight,' was published in 1531. It may be described as the earliest treatise on moral philosophy in the English language, the author's principal object being "to instruct men in such vertues as shall be expedient for them which shall have authoritie in a weale publike." An elaborate 10th edition appeared in 1880, with life notes and glossary by H. H. S. Croft.

Elyot's 12 other works include 'Of the Knowledge which maketh a Wise Man' (1533); 'Pasquill the Playne' (1533); 'Isocrates', 'Doctrinal of Princes' (1534); Picus de Mirandola's 'Rules of a Christian Lyfe' (1534); 'The Castel of Helth' (1534); 'The Bankette of Sapience' (1534); 'Bibliotheca' (1538), the first Latin-English dictionary; 'The Image of Governance' (1540); 'Defence of Good Women' (1545); and 'Preservative against Deth' (1545). These books went through edition after edition in their author's lifetime, and have now become among the rarest treasures of book collectors.

**ELYRIA**, Ohio, city and county-seat of Lorain County, on the Black River and on the Baltimore and Ohio and Lake Shore and Michigan Southern railroads, 25 miles southwest of Cleveland. It has a public library, a hospital and a fine natural park. Agriculture is the chief industry of the surrounding country; the sandstone quarries furnish employment to a number of people. The chief manufactures in the city are supplies for automobiles and bicycles, saddles, telephones, home-lighting plants, flour, feed, canned goods, concrete blocks, moldings, paints, metal polish, switchboards, screws, machine parts, iron pipe, angle iron, strip steel, etc. The United States census of manufactures for 1914 showed within the city limits 63 industrial establishments of factory grade, employing 3,236 persons; 2,735 being wage earners, receiving \$1,759,000 annually in wages. The capital invested aggregated \$9,485,000, and the year's output was valued at \$8,792,000; of this, \$3,776,000 was the value added by manufacture. The waterworks are owned by the city. Pop. 17,396.

**ELYSÉE**, Palais de l', pã-lã de lâ-lë-zã, the official residence of the President of France, in Paris, on the Rue du Faubourg Saint Honoré, with its garden extending to the Champs Elysées. It was built in 1718 for the Count d'Evreux; in the reign of Louis XV it became state property and was the residence of Madame de Pompadour. It was also used as a residence by Napoleon I and by Louis Napoleon, and became the presidential residence in 1871.

**ELYSIAN FIELDS**, or **ELYSIUM**, in classical mythology, the residence of the blessed after death. Elysium was supposed by Homer to have been at the western end of the earth; other poets placed it in the Fortunate Isles; later it was supposed to be in the under world. It was represented as a region of perfect happiness, where the sky was always cloudless and a celestial light shed a magic brilliancy over every object; where each one was free to follow his favorite pursuit, and cares and infirmities were unknown.

**ELZE**, ɛl'tsë, **KARL**, German historian of literature: b. Dessau, 22 May 1821; d. Halle, 22 Jan. 1889. His specialty was English literature, and he was professor of English philology in the University of Halle 1875-89. One of his first works was a compilation entitled a 'Treasury of English Song.' He produced critical editions of Shakespeare and other English dramatists, and wrote biographies of Byron and other English authors. Specially noteworthy is his 'Grundriss der englischen Philologie.'

(1877). 'Westward' (1860) contains translations of English and American poems.

**ELZEVIR**, *ě'zě vır*, name of a notable family of printers descended from Ludovic Elsevier or Elzevier, Latinized Elzeverius, a native of Louvain: b. 1540; d. 1617. Having learned the bookbinders' trade, he practised it for some years in his native town, but in 1580 he removed to Leyden in the United Provinces and there set up a printing press. His five sons, Matthew, Ludovic, Egidy, Joost and Bonaventura, were also printers and booksellers; but it was the youngest of the five, Bonaventura, born 1583 at Leyden, that gave the name Elzevir its great celebrity. The first work published by the house of Elzevir appeared in 1583, the 'Ebraicæ Quæstiones et Responsiones' of Drusius, not the whole three books, but only the second and third. In 1608, nine years before his father's death, Bonaventura Elzevir founded a separate printing and publishing establishment in the same city and then commenced the issue of works in Greek, Latin and other languages which have ever since been regarded as models of correct and elegant typography. He conducted the business of his house more than 42 years, till his death in 1652, having had as partner from 1626 Abraham Elzevir, his nephew, whom he survived one month. He was succeeded by his son Daniel and Abraham's son John; this partnership was soon dissolved, John carrying on the business in Leyden, Daniel migrating to Amsterdam in 1655 and entering into partnership there with another of his cousins; both of these were dead 1680. The last of the Elzevirs to figure in the history of typography was Abraham, son of Abraham, one of the five sons of Ludovicus; from 1681 to 1712 he was printer to the University of Leyden. The Elzevir editions of the ancient classics, especially Latin, while admirable in point of typography, are mostly reproductions of the texts adopted by previous printers and hence are inferior from the critical point of view. The number of works published by the different Elzevir houses nears the 2,000 mark.

**EMANCIPATION**, the act by which freedom of various kinds is granted to individuals, races or nations. In Roman law the dissolution of paternal authority (*patria potestas*) in the lifetime of the father. It took place in the form of a sale by the father of the son to a third party, who manumitted him. The Twelve Tables, the foundation of Roman law, required that this ceremony should be gone through three times. In general, the son was at last resold to the father, who manumitted him, and thus acquired the rights of a patron which would otherwise have belonged to the alien purchaser who finally manumitted him. In the case of daughters and grandchildren one sale was sufficient. This form of emancipation continued in the Empire until the time of Justinian, who substituted a declaration by the father before a proper tribunal. This emperor also changed the succession law, by making kinship by blood decisive. According to Teutonic law the marriage of a daughter freed her from parental control and a son became free upon setting up a home of his own. In modern states liberty from parental authority comes on attaining full age. If a person receives his freedom before attaining full age he is said

to be "emancipated." For full information on this question it is necessary to consult the various codes. The Catholic Emancipation Act was the act signed 13 April 1829, which removed the most galling of the Roman Catholic disabilities in England. See **EMANCIPATION, CATHOLIC; EMANCIPATION PROCLAMATION; SLAVERY.**

**EMANCIPATION, Catholic**, the customary designation of a measure of relief from penalties and civil disabilities granted to professors of the Catholic religion in England and Ireland by acts of the British Parliament 1829: the act did not extend to Scotland. The necessity of granting relief to the Catholics of Ireland became apparent soon after the outbreak of the war against the American colonies, and the first relaxation of the penal laws against the professors of the Catholic religion was made in 1780. At that time it was high treason for a priest, native of the kingdom, to perform any of the duties of his office. Catholics could not own land in fee. Roman Catholics whose titles to land antedated the penal laws were ousted if the legal heir professed Protestantism. A Catholic could not practise law, nor conduct a school. In 1780 a bill for removal of some of the disabilities was passed for England and Ireland. When the act of union of the kingdom of Ireland with that of Great Britain was passed in the Irish Parliament 1800, solemn pledges were given by the British Cabinet that the disqualifying statutes should be repealed; but after the union the promise was ignored. In 1824 in Ireland was formed the Catholic Association to agitate for civil rights, such as the right to vote for members of the Parliament, to be elected members of the same and to occupy various offices in the government, national and local. In 1829 it was seen by English statesmen that to withhold these rights and franchises any longer would provoke a rebellion in Ireland; and a bill of relief was introduced in the Parliament 5 March, and passed in both houses and approved by King George IV 13 April, permitting Catholics to elect and be elected to the Parliament, and to hold offices under the Crown; but they remained still expressly excluded from certain high offices—that of lieutenant-governor of Ireland, that of regent of the universal kingdom, or lord chancellor of the United Kingdom, or of Ireland, etc. In 1867 the last named disability was removed, as was, many years after, the disability of a Catholic to be lord chancellor of the United Kingdom. But the Act of Grace of 1829 contained a clause forbidding Catholic ecclesiastics, monks, friars and nuns from wearing the attire or habit of their respective station or order in public under a penalty of \$250 for each offense. This proviso was ostentatiously violated in Ireland, and with impunity, for, like the \$500 forfeiture for violation of the Ecclesiastical Titles Acts (q.v.), no penalty was ever exacted. Another clause of the Catholic Emancipation Act, which was also ignored and condemned, required that Jesuits and members of religious orders of the Roman Catholic Church living within the kingdom should register in the office of the clerk of the peace of the county under a penalty of \$250. (See O'CONNELL, DANIEL). Consult Butler, 'Historical Memoirs'; Milner, 'Supplementary Memoirs'; Lingard, 'History



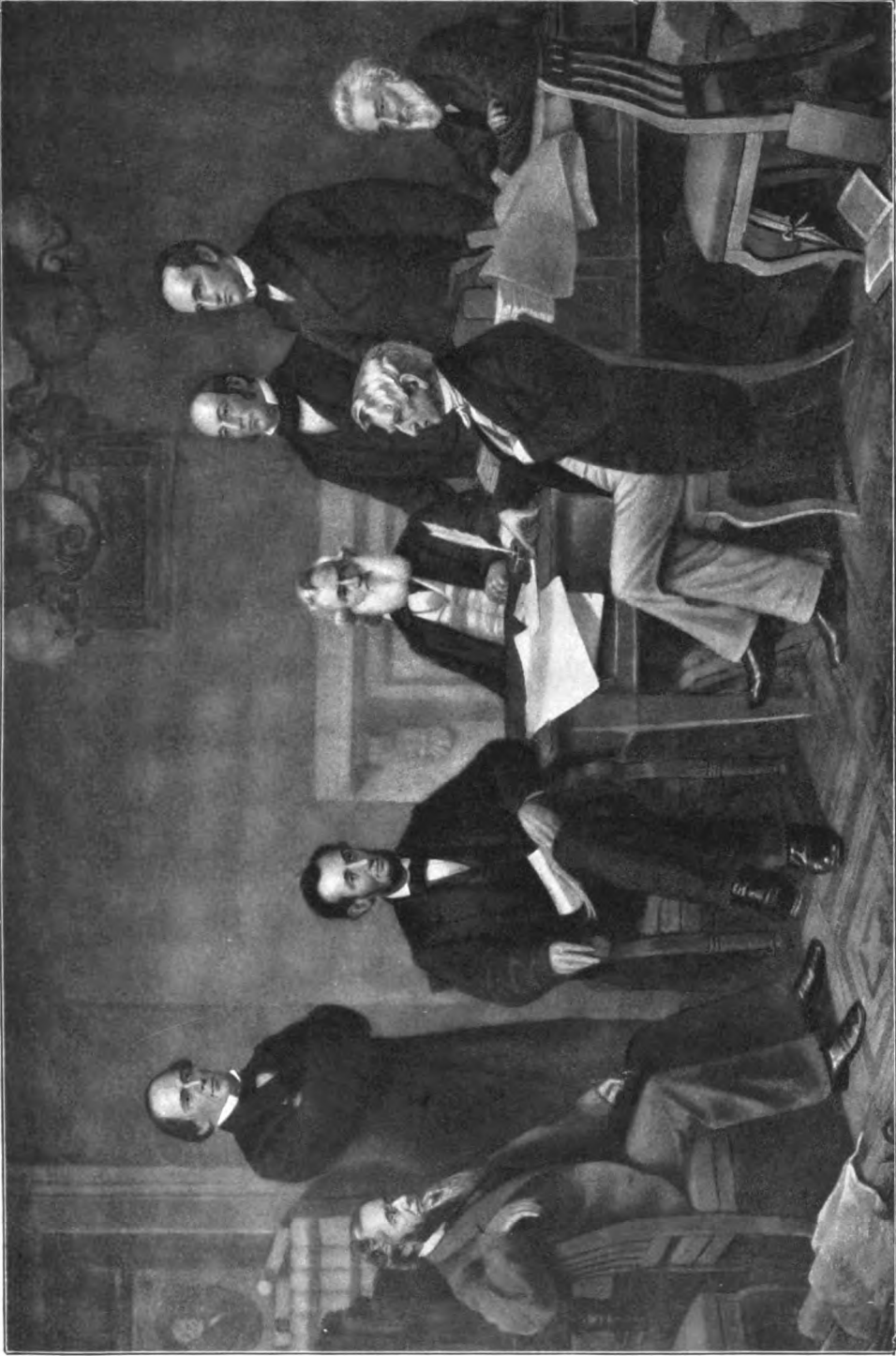

From the Painting by Carpenter

**SIGNING THE EMANCIPATION PROCLAMATION**



of the Church in England'; Green, 'History of England.'

**EMANCIPATION IN LATIN-AMERICA**, the Manumission of Slaves in Relation to the several Declarations of Independence. In Haiti, where African slavery was first introduced into America, the negroes received as a gift "the full liberty, equality, and fraternity" of the French republic in 1794, and by fighting established their independence in 1804. In Central America (when Guatemala, Salvador, Honduras, Nicaragua, and Costa Rica were united in the Central American republic), the laws of 31 Dec. 1823 and 17 and 24 April 1824 emancipated all slaves, and made free, slaves of other countries coming to Central America. The slave trade was prohibited, under penalty of forfeiture of the rights of citizenship. H. H. Bancroft, in his 'History of the Pacific States,' says "Of all the nations of North America, to the Central American republic belongs the honor of having first practically abolished slavery." We shall presently show, however, that this distinction fairly belongs to Mexico. Ecuador, which made its first effort to gain independence at Quito, 10 Aug. 1809, and actually threw off the yoke of Spain on 9 Oct. 1820, abolished slavery during the presidential term of General Urquina, 1852-56. The Argentine nation began its struggle for independence 25 May 1810, and at the Congress of Tucuman, 9 July 1816, the formal separation from Spain was declared. Article XV of the constitution of 25 Sept. 1860 provides that "there shall be no slaves in the Argentine nation. Those few who now exist in it shall become free at the very moment this constitution goes into effect. The indemnification which the declaration may involve shall be provided for by special law. Any contract involving the purchase or sale of a person shall be held to be a criminal offense. . . . Slaves introduced in any way whatever into the country shall become free by virtue of the fact that they have trodden the soil of the republic." In Colombia (New Granada) the number of negroes was never very great; it was estimated at 80,000 in the middle of the 19th century. The struggle for independence, beginning 20 July 1810, or as a vigorous insurrection in 1811, was continued after the union with Venezuela (December 1819), and the republic of New Granada was formed in 1831. In 1821 a law was passed by the republic of Colombia for the gradual manumission of slaves, and all born after that date were declared free at the age of 18,—that gradual process applying, of course, to all the territory of the Greater Colombia at the time of the law's enactment. (See *COLOMBIA, History*). A law of 1851 abolished slavery entirely in New Granada, by giving liberty to all who remained slaves on 1 Jan. 1852, provision being made for the payment of indemnity to the owners. The beginning of the war for independence in Mexico dates from 16 Sept. 1810 (see *DOLORES, EL GRITO DE*); on 6 Nov. 1813 the first Mexican Congress, installed in the town of Chilpancingo, issued the declaration of independence and decreed the emancipation of slaves. This, therefore, was the starting point of emancipation on the mainland of America. Venezuela's declaration of independence (5 July 1811) was followed after 10 years by the

law for the gradual manumission of slaves which we have mentioned above, that is, the law of the Greater Colombia of 1821. Paraguayan independence should be dated from 11 June 1811, when an assembly of deputies began its sessions; for the resolution passed by this assembly, renouncing allegiance to Spain, was ratified as a declaration of independence by the Paraguayan Congress of 1 Oct. 1813. The question of African slavery was comparatively unimportant in Paraguay. "In 1865 there were negroes and mulattoes at Emboscada, Tabapy, and Aregui; but the negroes have now almost completely disappeared" ('Handbook of Paraguay,' September 1902, issued by International Bureau of the American Republics). Chile entered upon a contest with Spain on 18 Sept. 1810, and the independence of the country was proclaimed 12 Feb. 1818. The negro problem did not weigh upon that country, the population being recruited from Europe quite largely. The independence of Peru was declared at Lima 28 July 1821; that of the Dominican republic 1 Dec. 1821; that of Brazil 7 Sept. 1822; and Bolivia became an independent republic 6 Aug. 1825. In Brazil the conservative statesman, Silva Paranhos, obtained from the Parliament the passage of a bill (28 Sept. 1871) for the gradual extinction of slavery, which provided that thereafter every child born of a slave mother should be free, and created a special fund for emancipation by redemption. Private philanthropy, largely directed by the Masonic lodges, effected more than the fund created for this purpose; and the number of slaves began to decrease. A bill for the immediate and unconditional abolition of slavery in Brazil was signed by Princess Regent Isabel 13 May 1888; the monarchy was overthrown 15 Nov. 1889; the new constitution approved 24 Feb. 1891. In Cuba the slaves were emancipated on the conclusion of the Ten Years' War, that is, in 1878, and Cuba became a republic 20 May 1902. The experiences of the French, Danish and British possessions may be referred to briefly in conclusion. Napoleon restored slavery in French Guiana, Martinique and Guadeloupe, although his efforts to accomplish the same result in Haiti were, as mentioned above, frustrated by the resistance of the blacks themselves. The freedom of all who were held in bondage throughout the French dominions was declared in 1848. Slavery in the Danish West Indies (Saint Thomas, etc.) was abolished also in 1848. The act to abolish slavery throughout the British colonies, providing £20,000,000 for compensation of the owners, was dated 28 Aug. 1833, and its effect was to free 770,280 slaves on 1 Aug. 1834, the number thus emancipated in Jamaica being 309,000.

MARRION WILCOX.

**EMANCIPATION PROCLAMATION**, the announcement issued by Abraham Lincoln 1 Jan. 1863 abolishing slavery in all military sections of the South except those territories occupied by Union arms. The Republican administration at the outbreak of the Civil War was awkwardly placed for dealing with slavery. To assail it in its own territory was not only to belie the past professions of the party, but to alienate so much Northern support as to assure failure; nor indeed had the great bulk of the party any thought beyond fettering the slave

power for future aggression. On the other hand, to leave slavery untouched was not only to chill the energies of the most reliable upholders of the War, but to give foreign countries a pretext for asserting that the North was fighting merely for dominion, and that the Southern cause was that of liberty and morally entitled to help. The former horn of the dilemma was much the sharpest; and the government moved very cautiously, restraining its subordinates like Fremont (30 Aug. 1861) and Hunter (9 May 1862) from forcing its hand by emancipation orders. On 9 Aug. 1861 an act had declared masters employing slaves against the government barred from further claim to them; but that was a mere warning and rule of court. The first embarrassing problem was how to deal with slaves in conquered districts, or who had come within its lines: was the government to act as slaveholders' trustee and return them to servitude? The growing resentment against slavery as a convertible term for the rebellion, and disgust at being slave-catchers to the behoof of their enemies, supplied the answer, and on 13 March 1862 all army officers were forbidden to return fugitive slaves; their surrender from any quarter was made harder (though the Fugitive-Slave Law was not formally abolished till 28 June 1864); on 17 June 1862 all captured, deserted or fugitive slaves of owners in rebellion were freed. As to the main body who plainly could not be left in unchanged status as the core of a fresh abscess, Lincoln's wish was for compensated emancipation; he sent a special message to Congress 6 March, and that body passed a joint resolution 10 April, declaring that the United States ought to co-operate with any State which would adopt gradual abolition, by paying for the slaves, and on 16 April those in the District of Columbia were thus emancipated; but despite his repeated urgencies, the border States would take no measures of the kind. On 19 June the slaves in the Territories were freed.

The final blow came, as John Quincy Adams 20 years before had forecast that it would, by using the President's war power to suppress insurrection. As the second year of the conflict wore on, the majority demanded the crippling of its enemy by the most efficient means, and very many believed that a threat of general emancipation would bring about a general surrender. Lincoln wished for a great victory first, that it might not appear the selfish resource of an overmatched power; but the discouraging Peninsular campaign obliged him to satisfy his supporters by holding this bludgeon over the enemy. On 22 Sept. 1862 he issued a proclamation announcing that 100 days after, on 1 Jan. 1863, the Executive would issue another proclamation designating the States or parts of States then deemed in rebellion, evidence to the contrary being the presence of bona-fide representatives in Congress, that all slaves in the designated sections should be permanently free, and that the civil and military authorities of the United States would maintain their freedom, and would not repress any effort of theirs to make it good. The only result was a retaliatory proclamation by Jefferson Davis 23 December, ordering that captured negro Federal soldiers and their officers should be turned over to the States, and that Gen.

B. F. Butler should be hanged if captured. On the 1st of January the threatened proclamation was issued, as "by virtue of the power in me vested as commander-in-chief of the army and navy of the United States, and as a fit and necessary war measure for repressing said rebellion." It designated Arkansas, Texas, Louisiana except 13 "parishes" or counties, Mississippi, Alabama, Florida, Georgia, South Carolina, North Carolina and Virginia except West Virginia and seven other counties, as in rebellion, emancipated all the slaves in them; enjoined these freedmen to abstain from all violence except in self-defense, and to work faithfully for reasonable wages; announced that suitable members of them would be received into United States military and naval service, and for this act invoked "the considerate judgment of mankind and the gracious favor of Almighty God."

The curious feature of this proclamation is that it abolished slavery only in the sections not under the military power of the United States, and left it untouched in those which were, namely, the ones specially excepted by it, "which are, for the present, left precisely as if this proclamation were not issued." Hence it was argued by the Democrats that it had no legal force whatever, and emancipated no one; a question the Supreme Court never passed on. It was always accepted by the majority party, however, as a continuing act, applying as fast as any of that territory fell into the Union power, and not necessary to repeat. Politically, the results were enormous. Recognition of the Confederacy thenceforward meaning a flat maintenance of slavery instead of freedom, the entire anti-slavery sentiment of France and Great Britain was thrown against those countries' interference, which at once became unthinkable. It drove away many lukewarm Northern Republicans, and brought many local and State defeats to the administration; but it took the party "off the fence" and made it a coherent organization with one firm, open principle, for many years unassailable. In the South, as defeat meant emancipation by their enemies and it would be no worse if done by themselves, some of the leaders (as Lee) seriously thought of offering freedom to slaves to fight in their armies in the latter part of the war, hoping to save independence and the control of their own destinies at least.

**EMANTS**, ém'ants, Marcellus, Dutch poet and descriptive writer: b. Voorburg, near The Hague, 12 Aug. 1848. His volumes of travels display his keen observation and his poetical imagination. Among his best are 'A Journey Through Sweden' (1877); 'Monaco' (1878); 'Along the Nile' (1884); 'From Spain' (1886). He holds a permanent place in the literature of the Low Countries through his charming narrative poems, 'Lilith' (1879); 'The Shimmer of the Gods' (1883).

**EMANUEL THE GREAT**, king of Portugal: b. 31 May 1469; d. Lisbon, 13 Dec. 1521. He ascended the throne in 1495. During his reign were performed the voyages of discovery of Vasco da Gama, of Cabral, of Americus Vesputius and the heroic exploits of Albuquerque, by whose exertions a passage was found to the East Indies (for which the way was prepared by the discovery of the Cape of

Good Hope in 1486 by Bartolomeo Dias), the Portuguese dominion in Goa was established, the Brazils, the Moluccas, etc., were discovered. The commerce of Portugal under Emanuel was more prosperous than at any former period. The treasures of America flowed into Lisbon and the reign of Emanuel was justly called "the golden age of Portugal." He died deeply lamented by his subjects, but hated by the Moors and Jews, whom he had expelled. As a monument of his discoveries Emanuel built the monastery at Belem, where he was buried. He was a friend to the sciences and to learned men. He left 'Memoirs on the Indies.'

**EMBA**, ěm'bä, a river in the district of Orenburg, Asiatic Russia; the Russians call it Jemba, the Kirghiz, Dchem. It rises at three sources in the western slope of the Mugodchar foothills, flows sluggishly through an area of steppes, is about 200 feet wide and 500 miles long, and forms a delta at its embouchure in the Caspian. It is not navigable, but abounds in fish. The fortress Embinsk is built on its upper waters.

**EMBALMING**, the art of preserving the body after death. It was probably invented by the Egyptians, whose bodies thus prepared for preservation are known as mummies, but it also prevailed among the Assyrians, Scythians and Persians. It is at least as old as 4000 B.C. The Egyptian mummies were placed in costly coffins ready for sepulture; but were frequently kept some time before being buried—often at home—and even produced at entertainments, to recall to the guests the transient lot of humanity. The usual method of embalming among the ancients was as follows: The intestines and brains were taken out, and the cavities filled up with a mixture of balsamic herbs, myrrh, cassia, etc.; the arteries and other vessels were injected with balsams. The ancient Egyptians filled the cavities of the trunk with aromatic, saline and bituminous stuff. The cloths in which the mummies were swathed were saturated with similar substances. So effectual were some of the processes that after 2,000 or 3,000 years, the soles of the feet are still elastic and soft to the touch. By 700 A.D., when embalming practically ceased in Egypt probably 730,000,000 bodies had been thus treated; many millions of them are still concealed. In 1881 upward of 30 mummies of potentates, including that of Rameses II, were discovered together at Deir-el-Bahari. (See MUMMY). The Persians employed wax for embalming; the Assyrians, honey; the Jews aloes and spices. Alexander the Great was preserved in wax and honey. Desiccated bodies, preserved by atmospheric or other influence for centuries, have been found in France, Sicily, England and America, especially in Central America and Peru. The art of embalming was probably never wholly lost in Europe. The body of Edward I, buried in Westminster Abbey in 1307, was found entire in 1770. The body of Canute, who died in 1036, was found very fresh in Winchester Cathedral in 1776. The bodies of William the Conqueror and of Matilda, his wife, were found entire at Caen in the 16th century.

Chaussier's discovery, in 1800, of the preservative power of corrosive sublimate, by which animal matter becomes rigid, hard and grayish, introduced new means of embalming; but, ow-

ing to the desiccation, the features do not retain their shape. The discovery of the preservative power of a mixture of equal parts of acetate and chloride of alumina, or of sulphate of alumina, by Gannal, in 1834, and of arsenic by Tranchini, pyroxilic spirits by Babington and Rees in 1839, and of the antiseptic nature of chloride of zinc, have led to the application of these salts to the embalming of bodies required to be preserved for a limited time. The latest method common in the United States is an injection of a fluid into the femoral artery and the cavity of the abdomen. The most efficient agents are mercuric chloride, arsenic and zinc chloride. Embalming has taken the place of ice in preserving the dead until funeral services are ended. The reasons for this are its preservation of the body for transportation and leisurely disposal and its absolute prevention of communication of infection, either before the body is buried or after it has crumbled and mingled with earth in a cemetery. Consult Budge, 'The Mummy' (2d ed., London 1894); Dhonan and Nunnamaker, 'Hygiene and Sanitary Science' (Cincinnati 1913); Eckles, 'Practical Embalmer' (Philadelphia 1904); Gannal, 'Traité d'embaumement' (Paris 1838; trans. by Harlan, Philadelphia 1840); Myers, 'Champion Textbook of Embalming' (5th ed., Springfield, Ohio, 1908); Pettigrew, 'History of Egyptian Mummies' (London 1834); Smith, G. E., 'A Contribution to the Study of Mummification in Egypt' (Cairo 1906); Suquet, 'Embaumement' (Paris 1872). See DEAD, DISPOSAL OF THE; MUMMY.

**EMBANKMENT**. See LEVEE; MISSISSIPPI LEVEE SYSTEM.

**EMBARGO IN THE UNITED STATES**. Prohibition of foreign commerce, to distress foreign countries and obtain the revocation of hostile measures; "peaceful war," intended to be cheaper than actual warfare and equally efficient, but in fact injuring ourselves deeply and the others little, and ending in real war at last. Our embargoes belong exclusively to the French-English wars of 1794-1814. Their ultimate cause was that the agricultural classes, who controlled the administration, did not believe in commerce, and preferred abolishing it to spending anything for its protection; moreover, they were mainly Southern and Democratic, the commercial interests mainly New England and Federalist, and the former were not loath to spare themselves the cost of war by impoverishing the latter. The first embargo was for 60 days, due to mutual orders of France and England for seizure of neutrals which placed the United States between hammer and anvil. Jay's Treaty (q.v.) of 19 Nov. 1794, for 12 years measurably protected our commerce, but near its end conditions became infinitely worse. In 1806-07 the thronging mutual blows of England and Napoleon, ending in the former's Orders in Council of 11 November, and the latter's Milan Decree of 7 Dec. 1807, made practically every neutral vessel good prize to one or the other. Even more intolerable were the rights of search and impressment claimed by Great Britain, which swept several hundred American sailors every year into the British fleets, and in one massacre (see CHESAPEAKE AND LEOPARD) outraged and humiliated this country beyond forgiveness. But aside from the reasons above given, few landsmen believed

till the victory of Old Ironsides (see CONSTITUTION, THE) that American ships could fight English on equal terms, and it was the general conviction that in case of war our entire fleet would at once be "Copenhagenized" (that is, captured bodily and added to the British fleet, as was the Danish). At Jefferson's recommendation, therefore, The Embargo was passed 22 Dec. 1807, forbidding all foreign commerce till the obnoxious decrees were repealed. The havoc not only in trade but in the interior life of the people was terrific; the exports fell from \$110,084,207 in 1807 to \$22,430,960 in 1808. The farming sections were dismayed to find that commerce meant part of their daily bread as well as the carrier's profits and that they raised and sold much of that \$87,000,000; but they clung all the more stubbornly to their anti-war recipe, though England and France approved it highly. Napoleon was glad to see his enemy drifting into war with a western power; England was glad to regain her carrying trade and see Canada and Nova Scotia receive American capital. Meantime New England fought it with the fierceness of a struggle for life; evaded it largely by sea and sent armies of smugglers overland to Canada. Congress then extended the act to rivers, lakes and bays, and allowed collectors to seize on suspicion; and the next Congress, 9 Jan. 1809, passed a savage enforcing act with all the fury of baffled doctrinaires, imposing enormous fines, forfeitures and bonds and making the collectors supreme despots of their districts. New England was nearly in insurrection; the collectors were in danger of the fate of those under the Stamp Act, some resigned, others were sued in the State courts; the judges would give no findings against smugglers; finally the States threatened nullification and John Quincy Adams (a victim to its support) declared that they had resolved to withdraw from the Union at least temporarily, if force were used, and had opened negotiations with Great Britain. A Federalist declared in the Senate that blood would flow. The Democrats were frightened and hastily fixed (3 Feb. 1809) 4 March for its discontinuance. But the next month they had regained courage and passed a "non-intercourse act" to take its place; still prohibiting intercourse with France or Great Britain, but restoring it with other countries and allowing free coasting trade. This policy was continued till the War of 1812 opened. The hostility of New England to the war, only less destructive than the embargo and against her political feelings, induced the British government ostentatiously to relieve that section from the blockade, to sow discord and make a base of naval supplies; and on 17 Dec. 1813 a new embargo was laid to 1 Jan. 1815, which, however, was repealed 14 April 1814. Jefferson always asserted that the policy was the best and the embargo would have accomplished its object if New England would only have helped. It is now pretty generally agreed that the laying of the embargo was a great political and economic mistake and it is certain that, as a result of it, American shipping sustained between 1807 and 1815 almost irreparable damage. Consult histories of the United States through this period, as Schouler, McMaster, etc.; especially Henry Adams' 'History,' covering 1801-15, devoted to the causes and consequences of these measures.

**EMBASSY** (*ambassy*, from O. Fr. *ambassée*, from low Lat. *ambachus*, a servant, vassal) in its strict sense, signifies a mission presided over by an ambassador, that is, a diplomatic agent of the first rank, as distinguished from a legation or mission entrusted to an envoy or agent. The difference between the powers and privileges of an ambassador and an envoy is, that the former, as the representative of the person of his sovereign, can demand a private audience of the sovereign to whom he is accredited, while the latter must communicate with the Minister for Foreign Affairs.

**EMBER-DAYS**, called in the Roman Missal and Breviary *Quattuor Tempora* (the four seasons) and in the Anglican 'Book of Common Prayer' 'Ember-days at the four seasons,' are in the Roman and in the Anglican calendar the Wednesdays, Fridays and Saturdays which come next after 13 December, the first Sunday of Lent, the Feast of Pentecost (Whitsunday), and 14 September, respectively. In both the Latin Church and the Anglican these days are days of fasting. The *Quattuor Tempora* were observed at Rome in the time of Saint Augustine (the bishop of Hippo, early in the 5th century) and doubtless the observance was already of ancient date. The custom was brought into Britain by that other Saint Augustine who was the herald of the gospel to the Anglo-Saxons. It was anciently the custom for bishops to hold ordinations only on the Saturdays of the *Quattuor Tempora*. The origin of the phrase Ember-days cannot be definitely ascertained; but it is probably a corruption of *Quattuor Tempora*, as in German *Die Quatember* signifies the Ember-weeks.

**EMBEZZLEMENT** (O. Fr. *besiler*, to rifle, lay waste) is the fraudulent appropriation, as by a clerk, public officer, agent or other person of property entrusted to him. It must not be confounded with larceny, which is the wrongful taking and carrying away of the personal property of another, with the felonious intent of converting such property to one's own use without the consent of the owner. This "taking" implies a trespass, which does not exist in embezzlement. By common law, embezzlement was not a crime, but it has been universally made so by statute both in the United States and Great Britain. The earliest statute recognizing the offense was that of Henry VIII, c. 7 (1529). This act was passed with the object of remedying an admitted defect in the existent criminal law, by which persons who had fraudulently appropriated goods or money, coming into their possession legally, escaped all punishment, although their moral guilt was great. Obviously they could not be convicted of larceny, as their offense lacked some of the essential elements of that crime. The above-named statute, however, restricted the offense to servants and in 1799 another statute was passed extending it to include clerks. This act, not proving completely satisfactory, the Larceny Act, passed in England in 1901, which amended sections 75 and 76 of the Larceny Act of 1861, further extended the offense to include trustees, directors of companies and others. This act makes the offense a misdemeanor and provides that the punishment therefor shall be penal servitude for a term not exceeding seven years, or imprisonment, with or without hard

EMBROIDERY

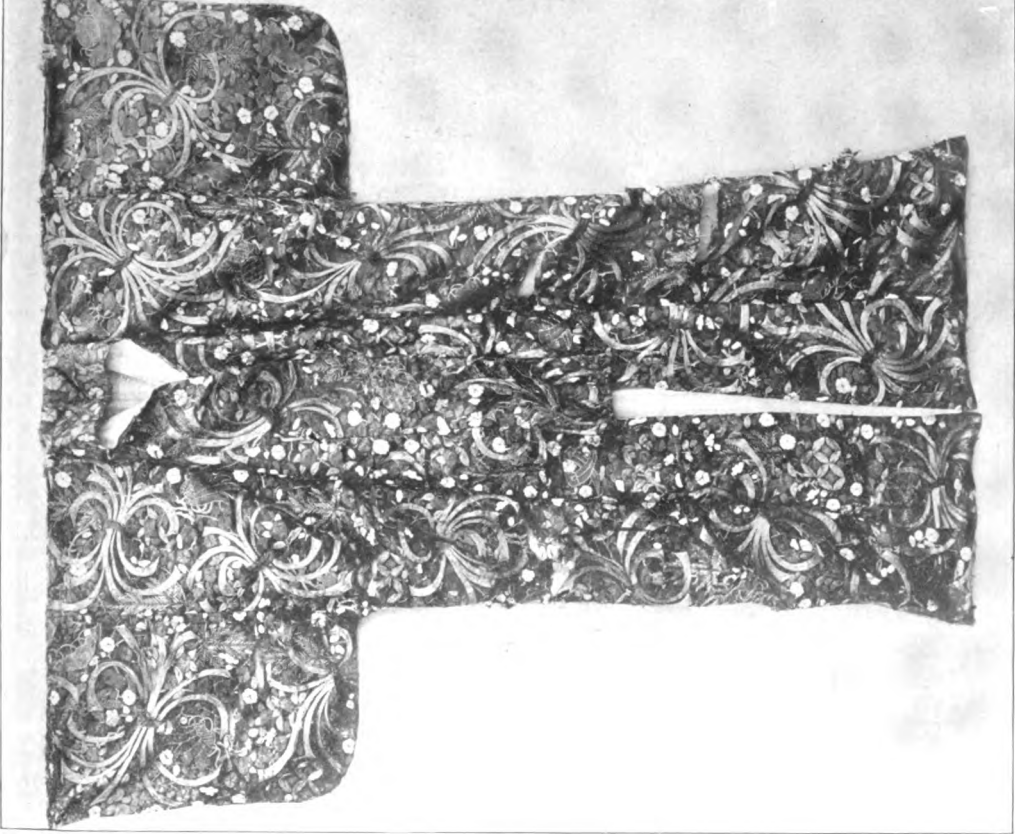

1 Japanese. Hoyo Period, 1704-1711. Costume for Uo Dance

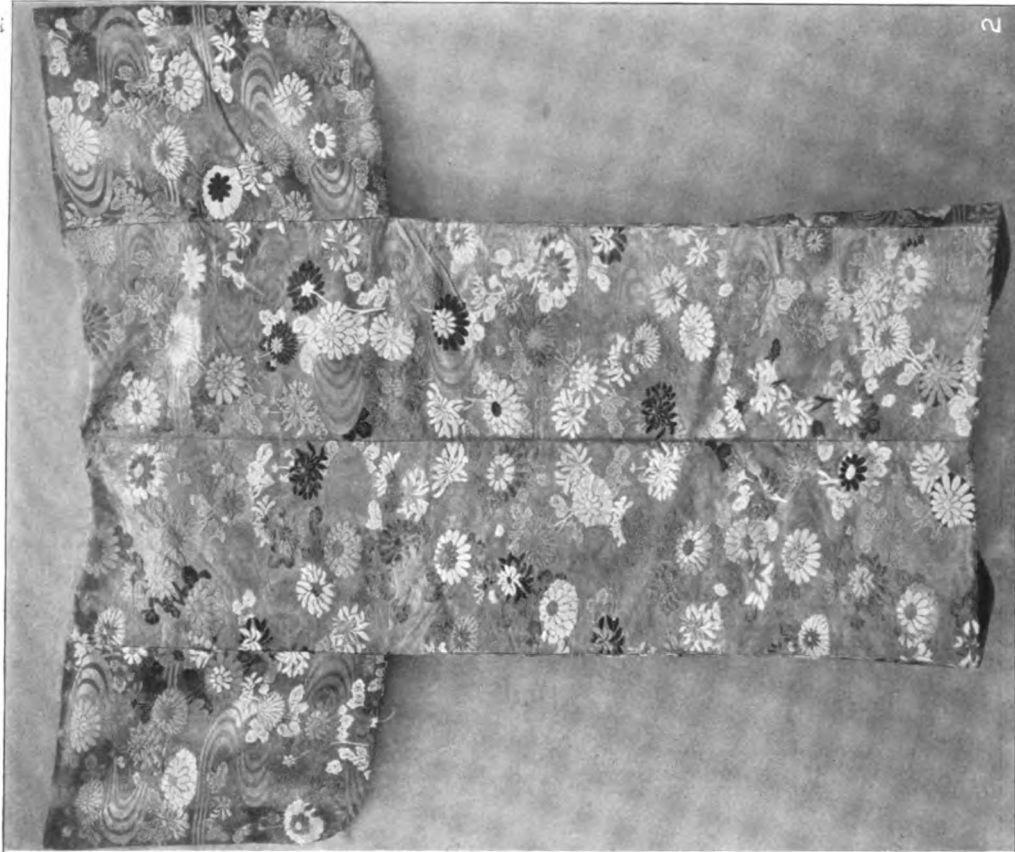

2 Chinese. Silk, crimson and gold. (In Metropolitan Museum, New York)

## EMBROIDERY

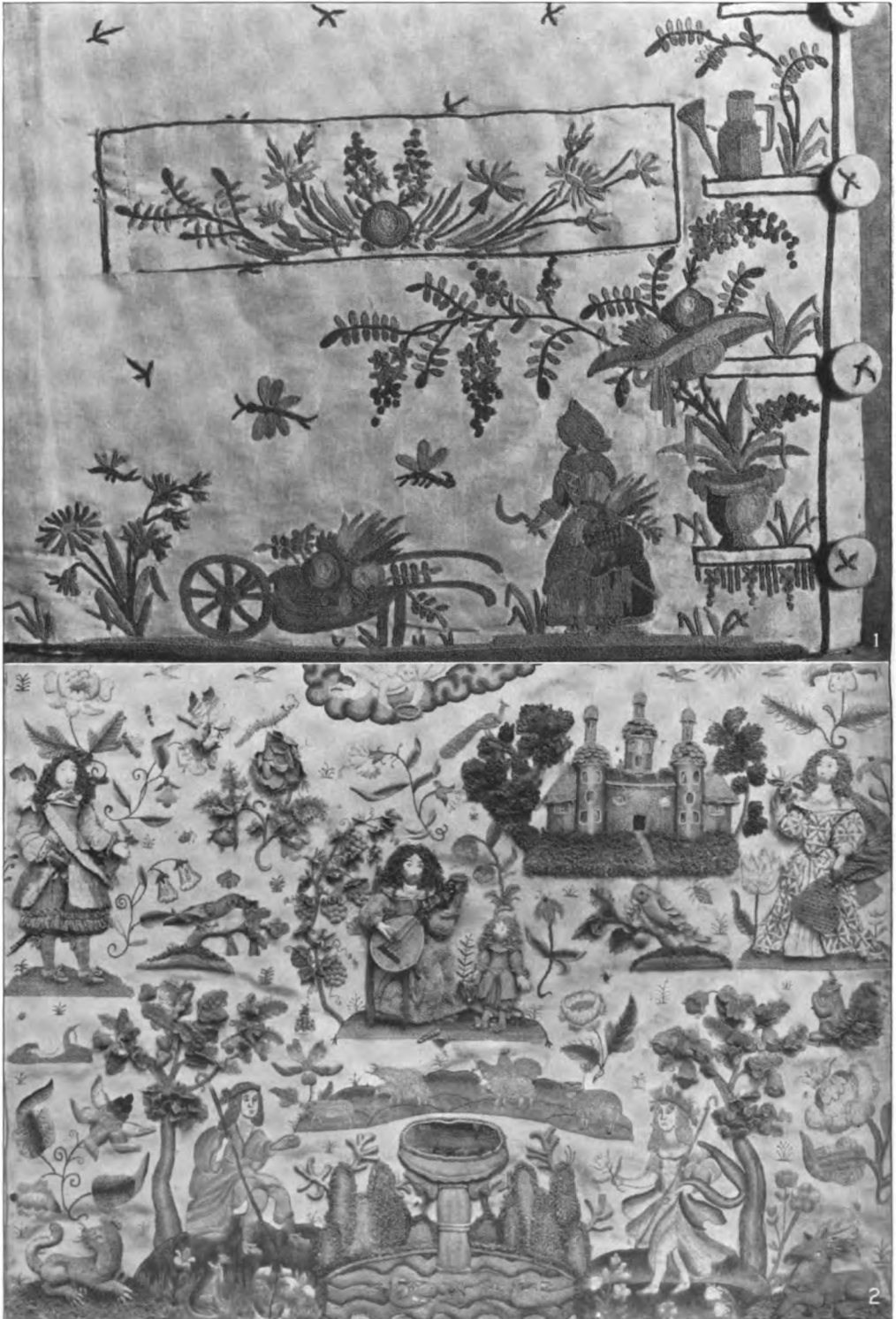

1 French. Louis XV  
2 English-Period, Charles I. A fine example of "stamp-work" (see article) characteristic design: figures, castle, animals, flowers and birds. (In Metropolitan Museum, New York)



labor, for a term not exceeding two years. In Scotland certain designated courts have inherent jurisdiction to punish all offenses, even when not declared to be crimes by statute, with the result that no legislation on the subject has been found necessary in that country.

Most of the statutes in the United States are based on the English act of 1799, but are much broader in their scope. In this country embezzlement is a misdemeanor or a felony, depending usually on the value of the property appropriated, although in some States embezzlement by an officer of a corporation or embezzlement of certain animals is a felony irrespective of the value of the property converted. Statutes often define embezzlement and mention is frequently found therein of the persons who may be guilty of the crime, as administrators, guardians, trustees, public officers, servants, agents and others who occupy fiduciary relations. It is essential to constitute the crime that the person charged therewith should have come into possession of the property by virtue of his employment and that he intentionally violated some confidence. There must also be a criminal intent to appropriate the property of another. Thus one holding property which is legally in his possession in the honest though mistaken belief that he owns it cannot be convicted of the crime. In some States, as Massachusetts and New York, embezzlement is included in the offense of larceny. The punishment differs in the various States, usually being imprisonment for a term varying from 2 to 10 years.

**EMBLEMENTS** (O. Fr. *emblaement*, from *emblaer*, to sow with grain), a term applied to the growing crops of land when the lease of a tenant for life has expired by the death of the tenant, or when an estate at will has been determined by the lessor. In either case the emblements belong to the tenant or his executors. But when the tenant puts an end to his occupation by his own voluntary act, he will not be entitled to the crops.

**EMBOLISM**, ěm'bō-lizm (Gr. *εμβολισμος*, intercalation, 'εν in, and *βάλλειν*, to cast). In the calendar, an intercalation of a day, as in the second month of our year in leap-year, or of a lunar month, 28 days, in the Greek calendar. In medicine, the blocking up of a blood-vessel by a clot of blood that comes from some distance till it reaches a vessel too small to permit its onward progress. The immediate cause or clot is called thrombus and the disease is known as thrombosis. See **PATHOLOGY**; **THROMBUS**; **THROMBOSIS**.

**EMBOSSING** (Fr. *bosse*, a protuberance), the art of producing raised figures upon plane surfaces, such as leather, paper, cardboard, metal, textiles, etc., by means of powerful presses furnished with dies of the desired pattern. Color embossing is done by two processes: (1) By applying the color to the raised part of the design, in which case the color is spread on the die with a brush and the whole surface cleaned, leaving the ink in the depressed parts of the engraving only; (2) by leaving the design uncolored and applying the color with a printing-roller to the flat portions of the die. For large designs, engraved plates or electrotypes are used with a counterpart of mill board faced with gutta-percha. Book-binding makes

extensive use of the art of embossing. Embossed wall-paper designs are effected by means of copper cylinders on which the design has been engraved, with counter parts of rollers of a softer surface. These are mounted on calendar frames. A common type of embossing machine has been adapted from the fabric printing cylinder machine, by engraving the cylinders in a suitable fashion. For some purposes the cylinders must be heated and kept at a high temperature while being used. Metal ornaments are likewise often made by an embossing process and finished and polished later. See **CHASING**; **REPOUSSÉ**.

**EMBRACERY** (O. Fr. *embraser*, to set on fire), an attempt to corrupt or influence a jury by money, promises, letters, threats or persuasions. This offense in the United States is punished by fine and imprisonment.

**EMBRASURE**, ěm-brā'zūr, in fortification, an opening made in the breastwork or parapet of a battery or fortress, to admit of a gun being fired through it.

**EMBRO**, a corrupted form of the name Edinburgh.

**EMBROIDERY**, the art of working on an already existent material a decoration with needle and thread. Form and shading are expressed by means of stitches; and it is essential in embroidery that the stitches must be frankly visible. Stitches are never concealed, nor disguised.

**Technique.**—A stitch is the thread left on the surface of the cloth after each ply of the needle. A piece of embroidery may be worked in one kind of stitch only, or a number of different stitches may occur in the one article. Embroidery stitches are ancient and have special names: Canvas (including cross, tent [*petit-point*] and cushion), crewel (also outline and stem), chain (simple, twisted, cable, zigzag and chequered), button-hole, feather, rope, fern, herring-bone, back, satin, basket, brick, braid, interlocking, overcast, plait, rococo, running, split-stroke, tambour, coral, darning, insertion, snail-trail, leviathan, ladder (Creton), two-sided Italian, trellis, old English knot, German knot, French knot, Rumanian, Holbein and many others.

Couching is the word used to define the method by which one thread is sewn down by another thread upon the material. Cord and braid, or a bundle of tiny threads, may also be "couched." Couching is much used in gold thread embroidery. Geometrical open fillings of leaves and backgrounds are often composed of lines of threads thrown across and couched down at regular intervals. The basket-stitch, which imitates wicker-work, is much used for couching.

Laid-work is an elaborate kind of couching. The stitches are laid down loosely on the surface of the material and then sewn down by cross lines of stitching. The Japanese use laid-work more extensively than any other nation. The Chinese, on the other hand, prefer to sew through the material, and, as a rule, their decoration is as beautifully embroidered on the wrong side of the material as on the right side.

"The Chinese and Japanese," writes Mr. Townsend, "are remarkable for flat treatment of plant-forms and are supreme in effects produced with one or two shades, partly through

their skill in placing the stitches. Constantly changing the direction of the stitches, they work for a pleasant play of light and shade acquired by the placing of the silk. They shade with the intention of showing where one shade ends and another begins. They are also fond of *voiding*, i.e., leaving the ground to show between the petals of flowers, similar to the use of 'ties' in stencilling."

Raised-work is formed by a layer of padding placed on the material and worked over with threads. It was popular in the 14th century and was carried to excess in the 18th century (particularly in England), when stump-work, in which figures were stuffed like dolls, was developed. Turkey-work, in imitation of Oriental rugs and carpets, appeared in the 16th century. It was worked in worsted and was used for table-covers, cushions and chair-seats. Eastern patterns were superseded by floral ones characteristic of the Renaissance; and these, in turn, by 18th century designs. Turkey-work chair-seats were plentiful in American homes in the 17th and 18th centuries. *Petit-point* or tent-stitch, is often used generically to describe the needlework that most nearly imitates tapestry. It enjoyed favor in the 16th, 17th and 18th centuries. Bargello, or Florentine, work is produced by the cushion-stitch on a canvas foundation, a blunt needle being used. Sometimes the satin-stitch is employed in combination with the cushion; the one for the pattern and the other for the background. Zigzag patterns are characteristic. Bargello was much used in the 17th century. It has lately been revived and is now very fashionable. Delicate line-work and color in mass are sought for by the expert and artistic embroiderer, who also takes delight in producing effects in shading and a beautiful finish by a perfect control of the stitches. Occasionally the worker uses a frame on which the material to be embroidered is stretched. The tambour-frame, shaped like a sieve, or drumhead, said to have originated in China, gave its name to the tambour-stitch. Chinese embroidery, exquisite in design and workmanship, has been unchanged for centuries. The devices and motives resemble those on porcelain vases and *cloisonnée* enamels. Nothing more beautiful than the embroidery on the robes of mandarins and noble ladies has ever been produced. Sometimes to the dragons, phoenix, flowers, butterflies, pagodas, clouds and temples the embroiderer adds something from his own fantastic imagination. The treatment of flowers in Chinese embroidery, in color, form and technique, is alone worthy of special study. The most beautiful Japanese work is on ceremonial robes on sashes for women and on the squares, called *fukusa*, used for covering fine presents. The best Japanese embroiderers live in Kioto. In the Mikado's collection at Nara there are specimens of Indian embroideries worked 1,200 years ago. India is said to have had some influence upon Japanese embroidery, though the chief source of inspiration was China.

Indian embroidery is done on silk, velvet, cotton, wool and leather. Most famous of all is the embroidery on wool, both loom-wrought and by the needle, of Cashmere, as shown in the Cashmere shawl. Muslin is embroidered at Dacca, Patna and Delhi. Rich embroidery in colored silk and gold and silver is made in Hy-

derabad and other places in Sindh. The embroidery of Nauanager and Gondal in Kathiwar (of which Cutch gets the credit) resembles that of Resht on the Caspian. Gold is also used in Cutch for embroideries in the Persian style of Isphahana and Delhi. The gorgeous gold-embroidered velvets of Lucknow, Gulbargah, Aurangabad and Hyderabad in the Deccan, used for canopies of state, umbrellas of dignity, elephants' cloths and state-housings, have remained unchanged from the earliest periods of Indian history; but their sumptuous gold-scroll ornamentation resembles Italian design of the 16th century. The Portuguese used to send satin to India to be embroidered in European designs and Oriental workmanship. Of such exquisite material were made many of the beautiful coats and waistcoats worn in the European courts in the 17th and 18th centuries. The embroidered native apparel of Cashmere, Amritsar, Lahore, Delhi, Lucknow, Murshedabad, Bombay and Vizagapatam are highly prized.

**History.**—Whether embroidery originated in China or India is a disputed point. The Chinese claim to have practised it 3,000 years B.C. India also boasts similar antiquity in this beautiful art. All ancient nations carried embroidery to perfection; for the art of the needle was developed before that of the brush. Thousands of years before the Bayeux Tapestry (q.v.) was worked with the needle to chronicle the Norman Conquest (1066 A.D.), if Homer may be believed, "Helen embroidered in her palace a large cloth, white as alabaster, with the story of the conflicts in which Trojans and Greeks contended for love of her." Embroidery was, therefore, not only an artistic enrichment of material, but it was used for centuries as a means of record and commemoration. Sacerdotal vestments, draperies and curtains for temples, robes of ceremony, clothes for ordinary use and household articles were embroidered with appropriate symbols and designs in colored wools, silks and threads of gold in every country of civilization. The Egyptians excelled in embroidery, rivaling the gorgeous work of the magnificent Babylonians. The Jews learned the art from Egypt, as is proved by the veil that Moses had made for the Holy of Holies "of fine linen embroidered with cherubim of blue and purple and scarlet."

The Greeks attributed the invention of embroidery to Athene; and a magnificently embroidered *peplos* hung behind her statue by Phidias in the Parthenon, and was renewed every five years. Persia was also famous for this art. Strabo speaks of the impression made upon the Greeks by the aerial and delicately embroidered fabrics, as well as the heavy and magnificent ones. Phrygia was so celebrated that all splendid embroideries were known in Rome as "Phrygian." Roman emperors were not behind others in patronizing the art. Even more sumptuous were the Byzantine emperors, whose robes were stiff with gold and of enormous weight with woven stitches. The favorite scheme of Byzantine embroidery consisted of pairs of birds or animals (often enclosed in circles), separated by the sacred tree of Persia, a kind of palm—the "tree of life." This Byzantine style dominated ecclesiastical embroidery throughout Europe during the Middle Ages when monasteries and convents had special rooms for male and female em-

# EMBROIDERY

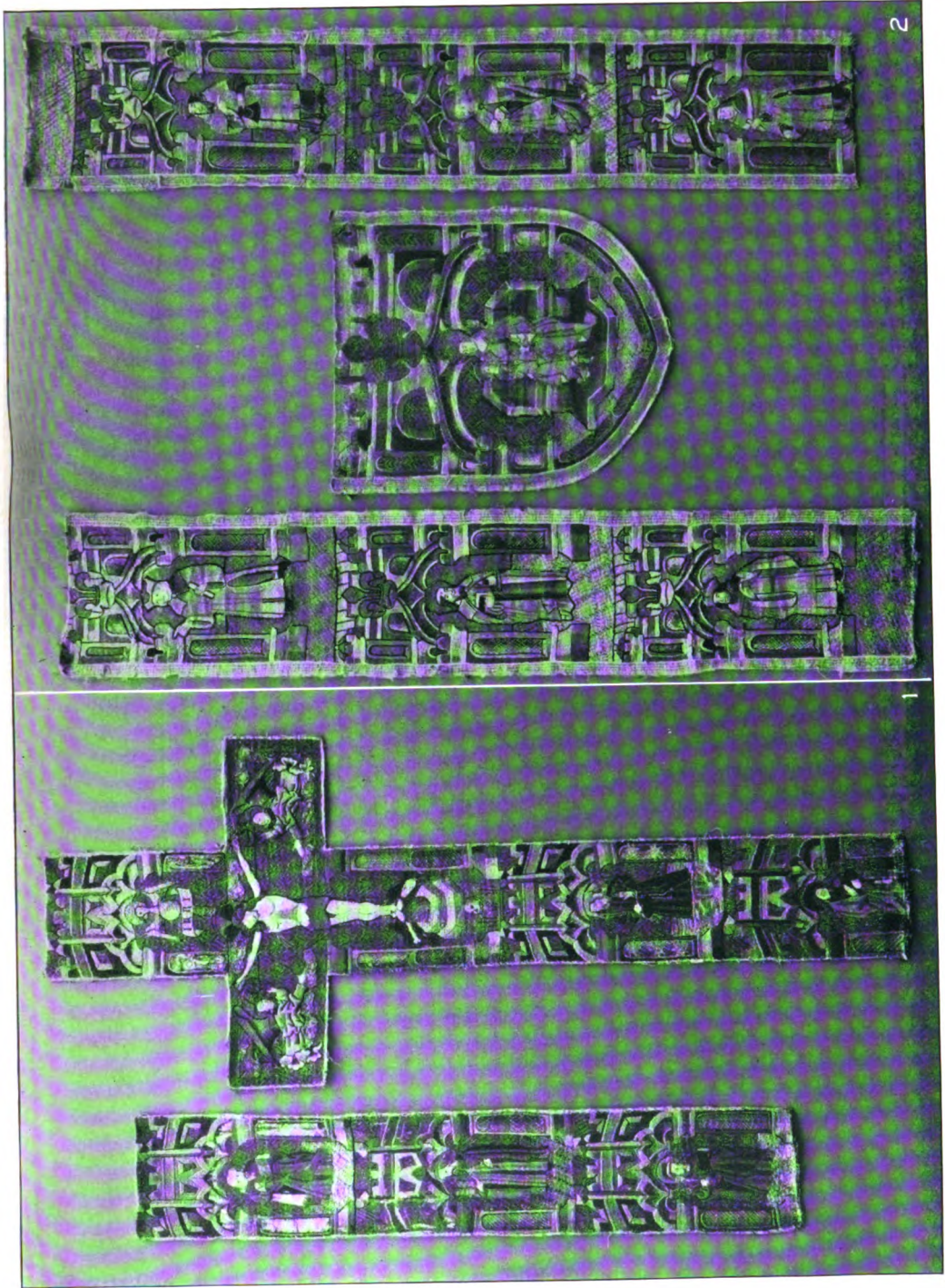

Ecclesiastical English Embroidery of the 15th Century ('opus anglicum'), representing orphreys (name given to this golden embroidery). The background is completely overworked and hidden by the needlework in gold, silver and silks of various colors in the style of the illuminated manuscripts of the period. (In Metropolitan Museum, New York)

## EMBROIDERY

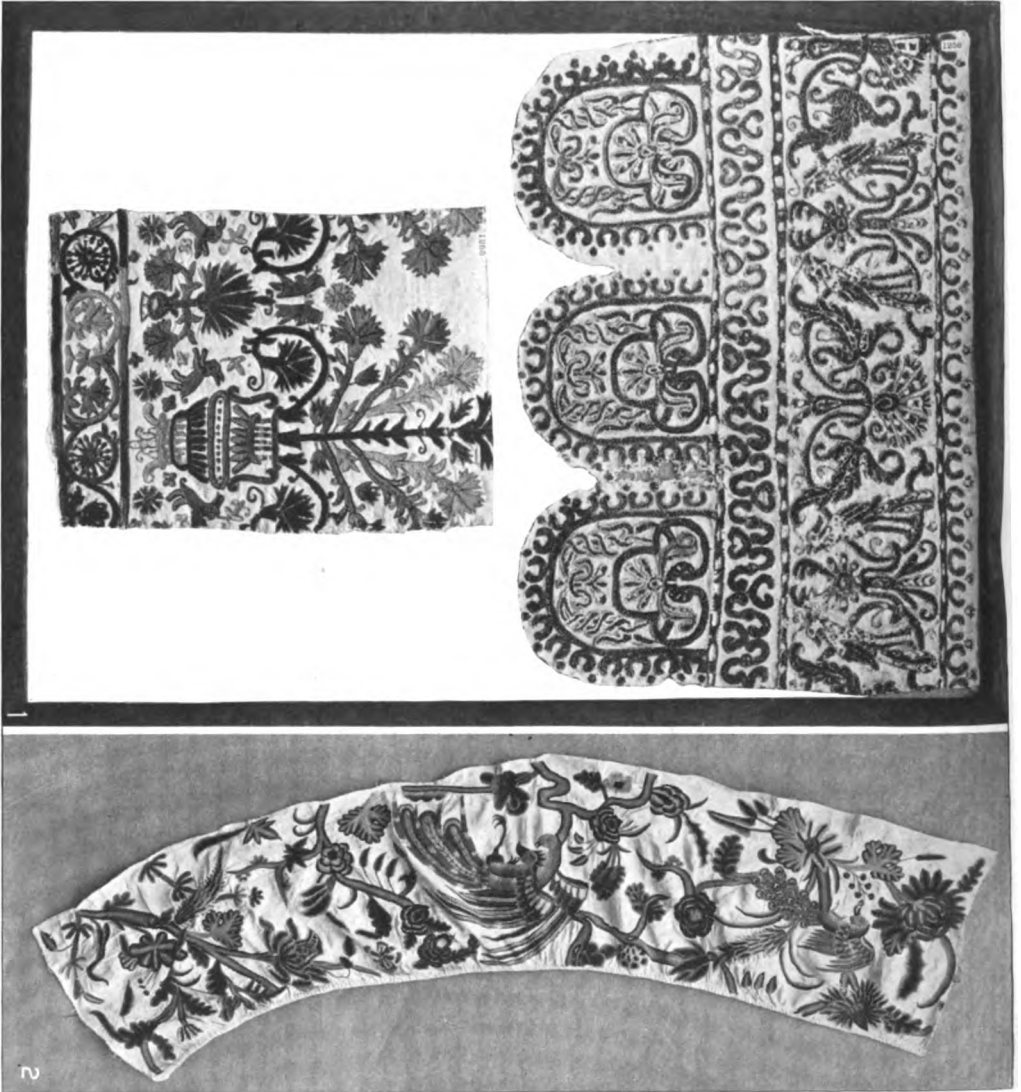

1 Italian, 16th-17th Century  
2 Valence; linen background with brightly colored crewels, or worsteds, design showing Indian influence. English, 17th Century. (In Metropolitan Museum, New York)

broiderers. Embroidery was also one of the most important subjects of instruction, ranking in dignity with painting and sculpture. Superb articles were worked on linen grounds with worsteds, silk and gold threads. Sometimes the entire material was covered with embroidery in the style of the miniature paintings in the illuminated manuscripts of the time; and it is noticeable that the great period of church embroidery, from the 12th to the 14th century, is also the great period of the illuminated manuscripts. In these "paintings with the needle," as contemporary writers call them, the English were the most celebrated. Their special work was known as *Opus anglicum*. It became so famous that great lords had to have specimens in their collections and many churches throughout Europe received gifts of this artistic production. The Syon Cope, now in the South Kensington Museum, is the most celebrated specimen in existence.

Embroidery was lavished not only on copes, chasubles, dalmatics, mitres, gloves and shoes for church ceremonials in the Middle Ages, but was also used to decorate the costumes of men and women and for draperies and household decoration. Beds were magnificent with embroidered draperies and counterpanes. Nor was it sufficient to embroider one set of bed and window hangings, but several sumptuous "sets of hangings" were produced to suit the changing seasons and various occasions. Hangings for tents were also marvelously embroidered and so were the armorial bearings of the knight on his surcoat and on his banners. Much of this work was done in the convents and monasteries and by the groups of embroiderers supported in wealthy homes and much of it was done by the accomplished and noble ladies. We know this from allusions in contemporary literature and in the detailed and descriptive entries in inventories and wills.

In the 16th century embroidery was no less used. It submitted, however, to Renaissance influence. Superb work was produced in Spain, Italy, France and England. Beautiful specimens exist in private and public collections and in the treasuries of cathedral and abbey churches; and, moreover, we have the paintings of the old Italian, Flemish and Spanish masters to show what gorgeous embroideries people wore. Household articles received much work from the embroiderer and also such small articles as purses, bags, handkerchiefs, gloves and covers for books. Sets of hangings for windows and beds were embroidered and "Turkey work" and *petit-point* chair-seats and cushions were made. Queen Mary and Queen Anne, like Queen Elizabeth and their Stuart ancestor, Mary Queen of Scots, were expert embroiderers. They followed in their designs the general taste of the day led by the artists of Louis XIV and inspired by the growing Eastern influence. Still employed to adorn costume, the art of embroidery grew ever more and more delicate; and in the days of Louis XV, when there was a rage for Chinese decoration, the handsome coats of courtiers and men of fashion were often sent to China to be embroidered according to order with European patterns. Floss and spun silks were now made up into various new threads, such as the fluffy velvet chenille, or caterpillar cord. Delicate gold and silver

threads were also produced; and with these pretty materials beads and spangles were often mingled to make the fantastic and graceful designs even lovelier by their added brightness and sparkle.

Embroidery was still exquisite in the days of Louis XVI and in the time of Napoleon. Josephine favored delicately embroidered and filmy muslins, which shared their vogue with Cashmere shawls. French, English and American fingers were soon able to produce lovely flowered and figured muslins and to decorate tulle and nets with "tambour" until machinery was invented to make their beautiful work unnecessary.

Within the last 30 or 40 years there has been a revival of artistic needlework—a movement in which Walter Crane and William Morris took the lead. Many art schools have been formed in the United States similar to that of the South Kensington Museum in London in which the stitches and styles of ancient and decorative embroidery are taught.

**Bibliography.**—Christie, Mrs. Archibald H., 'Embroidery' (London 1899); Day, Louis F., 'Art in Needlework: a Book about Embroidery' (ib. 1900); Dreger, 'Weberei und Stickerei' (Vienna 1904); Drew, Joan H., 'Embroidery and Design; a Handbook of Patterns' (London 1915); Higgin, L., and Alford, Lady Marian, 'Handbook of Embroidery' (ib. 1880); Jourdain, M., 'English Secular Embroidery' (ib. 1910); Kendrick, A. F., 'English Embroidery' (ib. 1905); Migeon, 'Les arts du tissa' (Paris 1909); Townsend, W. P. Paulson, 'Embroidery' (London 1907).

ESTHER SINGLETON.

**EMBRUM**, ön-brün (ancient *Eburodunum Caturigum*), France, town in the department of Hautes-Alpes, on a rocky eminence in the centre of a large plain watered by the Durance, 20 miles east from Gap. It is an ancient place, surrounded by walls and ditches, and of very picturesque appearance. The principal buildings are a cathedral and the archiepiscopal palace. It was pillaged successively by Vandals, Huns and Saxons, and its inhabitants almost exterminated by the Moors in 966. It is still a bishop's, and was once an archbishop's see. The manufactures consist of broadcloth, hats, yarns and farm tools. Pop. 3,812.

**EMBRYO.** See EMBRYOLOGY.

**EMBRYOLOGY**, that branch of biological science which is concerned with the development of the organism from the egg. The term is applied to the development of plants as well as animal organisms, but in the present article only the latter will be considered. Though every species of metazoan or multicellular animal produces eggs, not every individual arises directly from the egg. Indeed, in some groups asexual reproduction is commoner than sexual. It may occur by fission, or division of the organism into two or several individuals, as in certain flat-worms and annelids, or by gemmation, where new individuals bud or sprout out from the older ones, and either separate completely, or remain attached, forming colonies as in hydroids and bryozoans. However, strictly speaking, embryology applies only to the development of the organism from the zygote or fertilized egg-cell, or in some cases from eggs which develop by partheno-

genesis, i.e., without fertilization by a male gamete.

**Historical.**—Before the invention of the microscope observations on development were of the most superficial sort and the genesis of the organism from the egg was chiefly a problem for the philosopher. The relation of the embryo to the two parents was not in any sense comprehended and as late as the middle of the 17th century spontaneous generation was believed to occur in some animals, even by so great a physiologist as William Harvey. During the 17th and 18th centuries the theory of "evolution," later known as *preformation*, of which Bonnet, Leibnitz and Haller were among the greatest exponents, was the dominant view. Evolution in this sense denotes mere unfolding, like the flower from the bud, and has no relation to evolution in the sense of a theory of descent with modification. In brief, preformation is the doctrine that all the structures of the adult body are present in miniature in the germ and that development consists merely in their unfolding and growth. According to this theory nothing arises anew; as a corollary, known as the "emboitement" or box-within-box-theory, the germ must contain in diminishing series the germs of all succeeding generations. Naturally, most of the preformationists believed the germ to be contained in the egg, but after the discovery of the spermatozoa by Hamm in 1677, a new school arose known as the spermists or animalculists, who adopted the view that these minute motile bodies, so obviously living, contained the germs, the egg serving merely as a nutrient medium in which the minute but fully formed offspring of male origin was enabled to grow. Some of the spermists even published figures showing a miniature human body, the homunculus, enclosed in the spermatozoön.

An important advance was made in 1759 by C. F. Wolff, who demonstrated, from observations on the developing hen's egg, that bodily parts are not performed but actually arise anew in an orderly sequence, a theory which had been advocated though not proved by Harvey a century earlier and even vaguely stated by Aristotle. This conception, which is termed *epigenesis*, shortly supplanted the purely speculative preformation theory, but what regulated this epigenetic differentiation remained a problem and still remains the great problem of embryology, notwithstanding a vast amount of observation and experimental research. During the 19th century great progress was made in morphological or descriptive embryology and if space permitted many important discoveries might be enumerated. The greatest of the early investigators in this field is generally admitted to be Karl Ernst von Baer (1792-1876), sometimes called "the father of embryology," who, working mainly on the chick, was the first to give an orderly account of the chief phenomena of development, including cleavage of the egg, formation of germ-layers and the differentiation of organs. Von Baer also laid the foundations of comparative embryology.

The cell theory, formulated by Schleiden and Schwann in 1838, which has so completely revolutionized biological thought, led only gradually to the recognition of the unicellular character of the gametes, egg and spermatozoön, and despite the much earlier germ

theory of the spermists it was not until nearly the middle of the 19th century that the spermatozoa were generally recognized as the agents of fertilization; indeed by many naturalists they were regarded as parasitic micro-organisms, accidentally present in the fertilizing fluid. In 1843 Martin Barry witnessed the penetration of the rabbit's egg by the spermatozoön, but strange to say the unicellular character of the two gametes, a fact of fundamental importance, was not clearly demonstrated until after 1860. As a consequence of the rapid development of comparative embryology during the middle and latter part of the 19th century, together with the newly awakened interest in organic evolution, came the recognition of embryology as one of the greatest sources of evidence of phylogenetic relationship, and it is not surprising that a generalization known as the "recapitulation theory," namely, that the individual in its development repeats in brief its racial history, should have been developed. Though this theory has frequently been forced farther than the facts warrant, it is unquestionably true that embryology has yielded highly important data as to the relationships of classes and smaller groups within the same phylum, thus confirming in many instances evolutionary evidence from comparative anatomy and paleontology. The latter part of the 19th century and the earlier years of the 20th witnessed the development of a school of experimental embryology, concerned with the physiology and the philosophy of development, with the old problem of what makes the egg develop and what factors regulate the progressive differentiation of the embryo. In this field of morphogenesis some of the leaders have been Roux, Herbst and Driesch in Europe, and Loeb, Morgan and Lillie in America. Experimental studies have shown that while organs are not preformed in the egg, still in many cases the egg substance is differentiated into formative zones at, or even before, fertilization, that it exhibits in greater or less degree "germinal prelocalization" of material for future organs, but not the organs themselves. This predeterminism in the egg has been termed "promorphology." In eggs of some animals this is so definite that removal of a portion of the egg will result in the building up of an incomplete embryo, while in other cases a fragment of an egg, or each of the first four or eight cells of the segmenting egg if artificially separated, will give rise to an entire dwarf embryo; hence it is not possible to make categorical statements regarding promorphology in general. It is, however, a very different conception from the old preformation theory and does not imply a negation of epigenesis. In some types the normal promorphology, even though very early established, is readily alterable, in other cases it is not. As to the general factors of differentiation, the majority of physiologists undoubtedly incline toward a purely mechanistic explanation, or interpretation in terms of chemical and physical laws, but vitalism also has able exponents, notably Hans Driesch. A discovery of peculiar interest in connection with promorphology is the phenomenon known as "polyembryony," or the development of two or more embryos from a single zygote. The most familiar example is the production of the so-called "identical twins"

EMBRYOLOGY

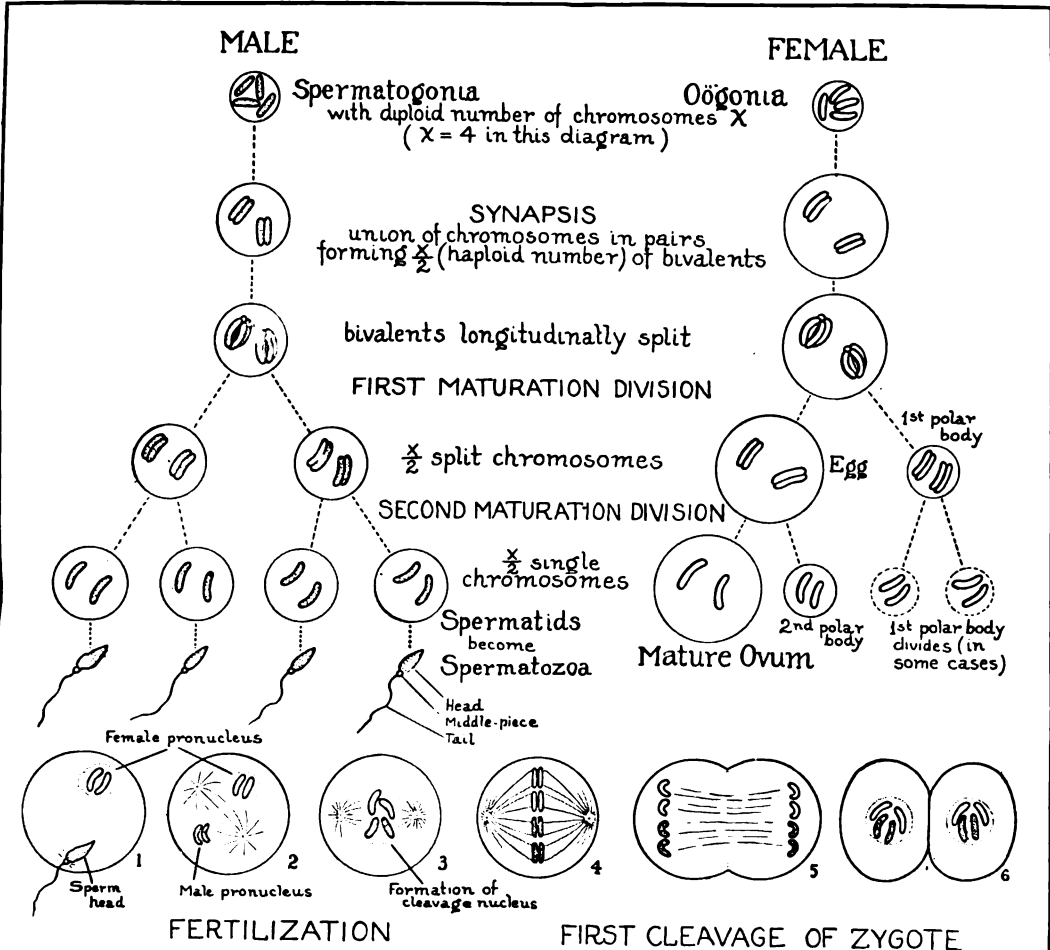

Fig. 1 Diagram of maturation of male and female germ cells, fertilization and the first cleavage of the zygote. (The paternal chromosomes are here differentiated by stippling)

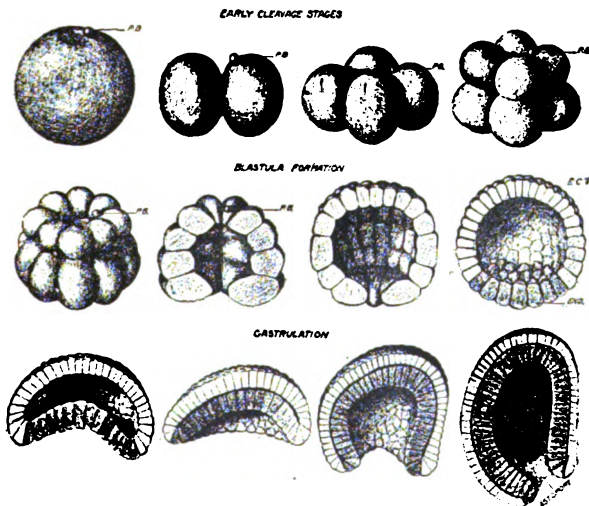

Fig. 2 Holoblastic cleavage, and formation of blastula and gastrula in *Amphioxus*, a low vertebrate. (The first five stages figured are surface views, the last six are represented as cut in the median plane.) From Calkins' Biology



Fig. 3 Diagram illustrating relations of extra-embryonic membranes in chick embryo at ninth day of incubation





in man and other species. These are always of the same sex. Ordinary or dissimilar twins, of course, arise from different ova and may or may not be of the same sex, as is the case in ordinary litters of young in mammals. In the nine-branded armadillo a litter contains four young, all of the same sex, and these have been conclusively shown to come from a single egg, and in a related species the polyembryonic litter contains eight or nine. In certain hymenopterous insects (chalcids) a single ovum produces a great number, in some cases hundreds of individuals. It follows from the method by which sex is determined at fertilization that all embryos thus arising from a single zygote must be of the same sex.

**The Germ Cells.**—The great generalization on which modern embryology is based is the cell concept as applied to the gametes. This is the fact that the ovum and spermatozoon are single cells of the parent organisms, and correlated with this the relatively new knowledge of the physical basis of heredity as located in the chromosomes. It is essential to realize not only that the gametes are true cells, but that they are exactly equivalent as regards their chromatin content and consequently their heredity-carrying capacity (with the exception of the sex-chromosomes, for which see the articles CELL and HEREDITY), and that their great diversity in size and form represents only a physiological differentiation by which the spermatozoon, minute and capable of locomotion is enabled to reach the egg, which as it is supplied with foodstuff for the future embryo is much larger and non-motile. It is scarcely possible to conceive of two types of cells more widely different in form and appearance, yet both are the descendants of similar primordial germ cells, and their differences, except for the sex-chromosomes above mentioned, are entirely in the extranuclear structures. The spermatozoa are proliferated in the testis in enormous numbers. In their commonest form, often described as tadpole-shaped, there is a head composed of condensed nuclear chromatin, a middle piece containing a centrosome, and a vibratile flagellum or tail by means of which the spermatozoon is actively propelled and enabled to reach the egg. Frequently also a pointed body, the acrosome, is present at the anterior end and facilitates penetration into the ovum. There is no relation between size of spermatozoon and size of organism. In man the entire length is 52-62 thousandths of a millimeter. In many minute invertebrates it is very much greater. In a few animals, the spermatozoa are non-motile and not of the usual flagellated form. The ovum, or egg, is always much larger than the spermatozoon, non-motile and usually of spherical form. During the elaboration of the egg in the ovary granules of inert food-yolk or deutoplasm are stored up in its extranuclear protoplasm. This food-yolk is rich in protein, fats, lecithin, etc., and serves during development as food for the embryo. The difference in size of eggs of different species is largely a difference in the amount of yolk and according to distribution of this substance eggs are described as (a) *alecithal* or *homolecithal*, having very little yolk evenly distributed as in the minute ova of mammals; (b) *telolecithal*, with the yolk massed toward one pole of the egg, the condition in most vertebrate eggs; and

(c) *centrolecithal*, in which central mass of yolk is surrounded by a superficial layer of protoplasm, a type occurring in some arthropods. The amount of yolk affects the development of the egg profoundly. The largest eggs are those of sharks, reptiles and birds, which are of extreme telolecithal type and comprise the largest cells known. Those of placental mammals are very minute, that of man only 17 hundredths of a millimeter in diameter. In oviparous animals the eggs are usually enclosed in protecting envelopes of which some are formed in the ovary and others secreted by the lining of the oviduct. In the hen's egg, to cite a familiar example, the delicate membrane surrounding the yolk is of ovarian origin, while the albumen, shell membrane and shell are oviducal secretions. Frequently, as in insects and bony fishes, the egg membrane is pierced by one or more minute pores, *micropyles*, which permit ingress of the spermatozoon at fertilization.

**Maturation.**—A phenomenon long known to be of almost universal occurrence in the history of the egg is the successive extrusion from it coincident with or shortly preceding fertilization, of two minute globules known as "polar bodies." The significance of these bodies long remained a problem, the solution of which during the later years of the 19th century constituted one of the most brilliant discoveries of cellular biology. It invested chromatin with a new importance, rendered possible a new understanding of germ-cells and fertilization and opened a new avenue for the investigation of the mechanism of heredity. It is a well-established fact that the cells composing the body (somatic cells) of every animal contain a definite number of rods of chromatin called chromosomes, this number characteristic of the particular species; also that these chromosomes are in even number and composed of two equivalent groups derived respectively from the two parents (an exception to this occurs in the case of the sex chromosomes. See articles on CELL and HEREDITY). By a series of researches beginning in 1883, in connection with which the names of E. Van Beneden, Theodor Boveri and Oscar Hertwig are especially identified, it was demonstrated that the ripe germ-cells of both sexes have only one-half the somatic number of chromosomes, though in the earlier primordial germ-cells the full somatic number occurs. This reduction is accomplished through a phenomenon known as "synapsis" or union in pairs of the chromosomes of paternal and maternal origin. Thus the somatic "diploid" number of single chromosomes becomes reduced in germ-cells to the "haploid" number of bivalent or double chromosomes, this reduction occurring in the spermatocyte or oocyte cell generation prior to the last two cell divisions known as maturation divisions, by which the definitive gametic cells are formed. During the maturation divisions the bivalent chromosomes are twice divided and the resultant univalent chromosomes distributed, still in haploid number, to each of the four resulting cells. In the male these four cells all develop into functional spermatozoa, but in the female the divisions are so unequal as to consist merely in the successive extrusion from the egg of two abortive eggs or polar bodies. In some cases the first of these bodies again divides so that

the end result is one functional egg and three polar bodies, which differ from the egg only in the smaller amount of cytoplasm and yolk, their chromatin content being exactly equivalent. The racial significance of the reduction of the number of chromosomes to one-half in both gametes will be obvious in connection with the union of these cells in fertilization. Fig. 1.

**Fertilization.**—"Fertilization" as applied to the union of gametic cells is a somewhat inadequate term, a relic of earlier days when it was supposed that the male semen merely activated the germ contained in the egg. While it is quite true that the spermatozoon does initiate development of the egg and thus "fertilizes" it in the same sense in which artificial treatment with chemicals may fertilize many kinds of eggs, another essential fact of the conjugation of the two gametes is the combination in the new zygote of two equivalent groups of chromosomes from the two parents. In many invertebrates and some aquatic vertebrates eggs and sperm are shed in the water, where conjugation occurs, but in many other animals the spermatozoa are transferred to the genital ducts of the female and fertilization is internal. Only one spermatozoon is normally concerned in the fertilization of an egg, though polyspermy, or the penetration of several into the egg-cytoplasm, frequently occurs, especially in forms having large eggs, but such supernumerary sperms always degenerate eventually and take no part in the formation of the embryo. When a spermatozoon comes in contact with the ovum it penetrates the cytoplasm and in many cases a delicate membrane, the fertilization membrane, is instantly secreted from the surface of the egg, thus preventing the entrance of any more sperms. At the same time other marked evidences of disturbance of the physico-chemical equilibrium occur, often with violent streaming and new arrangement of formative zones in the protoplasm, and in some eggs the promorphology is rapidly established at this time. The tail, which is of no further use after the sperm has reached the egg, is frequently left outside. The head upon entrance speedily enlarges and assumes a vesicular appearance, becoming the *male pronucleus*. The egg nucleus after the last maturation division is called the *female pronucleus*. Each of these pronuclei, as a result of previous reduction, has the haploid or halved number of chromosomes and by the union of pronuclei to form the zygote nucleus the normal diploid number characteristic of the species is restored. Thus reduction maintains the specific number of chromosomes from generation to generation. A centrosome, the function of which is to initiate the process of cell-division, is also introduced by the spermatozoon, usually in the middle piece, replacing the egg centrosome which disintegrates after the last maturation division. The zygote, as the fertilized ovum is called, is now a complete cell, really a new individual in the stage of a unicellular embryo, with its chromatin, the vehicle of heredity, derived equally from the two parents.

**Cleavage.**—Development of the zygote may be defined briefly as a progressive differentiation accompanied by cell-division and sooner or later by growth, but it must not be assumed that differentiation is determined by the cell division, for experimental embryology indicates

rather that the converse is the case. The term cleavage or segmentation is applied to the mitotic divisions by which the zygote is divided into numerous cells or blastomeres. When this process involves the entire zygote, it is described as total or holoblastic. In some cases the cells may for some time be equal in size, but where there is a unipolar aggregation of yoke, cleavage is mechanically retarded at the vegetal pole, the result being unequal cleavage, well shown in the egg of the frog, while if the yolk be very abundant cleavage may be partial or meroblastic, limited to a small disc of yolk-free protoplasm at the so-called animal pole, as in the hen's egg. In such cases this small disc, the blastodisc or blastoderm, gives rise to the entire embryo which gradually encloses, digests and absorbs the inert mass of yolk. In centrolecithal eggs of arthropods the cleavage is superficial over the entire egg. As a result of cleavage the egg in most cases soon attains the form known as the *blastula*, which in its most typical condition is a hollow sphere of cells containing a central segmentation cavity or blastocoel. Where yolk is very abundant the blastula is greatly altered and in some forms there is no true segmentation cavity and strictly speaking no blastula. See Fig. 2.

**Gastrula and Primary Germ Layers.**—The single-layered blastula becomes transformed into a *gastrula*, a two-layered sac-like stage, in which there is an outer cell-layer called *ectoderm* (or *ectoblast*) and an inner layer, the *endoderm* (or *endoblast*). This two layered stage is variously formed; in some cases, as in certain coelenterates, cells wander inward from one pole of the blastula forming a solid inner mass which later becomes hollowed out, but a far commoner method of gastrulation is that known as the embolic type, in which a part of the gastrula wall, generally the part richest in yolk, becomes turned in or invaginated as a result of unequal growth to form a cup-like endoderm. The new cavity thus formed in the endoderm is the *archenteron* or primitive gut cavity; the mouth of the sac is the *blastopore*, which in various animals may form the mouth or the anus or neither. This simple sac-like gastrula is found only in eggs which have very little yolk, thus among vertebrates it is met with in typical form only in amphioxus, though readily recognizable in lamprey, amphibian and some other forms, while in most vertebrates the abundant yolk masks the sac-like character of this stage. Frequently in eggs with abundant yolk invagination of endoderm is mechanically impossible and in such cases gastrulation may be effected by an overgrowth of the ectodermal layer which surrounds the large yolk-filled portion of the egg. Such overgrowth is termed *epiboly* in contradistinction to *emboly*, or in-turning of endoderm. However formed, the gastrula has considerable differentiation and foreshadows the orientation of the future body and some of the great organ systems. Its ectoderm is the source of the epidermis and the nervous system. The endoderm forms the lining of the gut and later gives rise to out-growths which become the chief digestive glands. These two layers are called the primary germ layers and are of well-nigh universal occurrence. In those vertebrates which have very abundant yolk and consequent partial cleavage, as well as in mammals which seem to

retain the developmental mode of forms with large eggs, the two-layered stage is so modified as to be scarcely recognizable as a gastrula and in such cases the blastopore becomes compressed and drawn out into a longitudinal *primitive streak* which is almost the earliest evidence of the body axis.

**Mesoderm.**—In all animals above the cœlenterates a third germ layer called the *mesoderm* (or *mesoblast*) develops between the two primary layers and gives rise to the connective tissue, muscles, blood system and gonads. This layer arises in very diverse ways. In many worms it is segregated very early in cleavage as special mesoblast cells. Usually it appears much later as a differentiation from the endoderm or in rare cases even from the ectoderm. In its origin from the endoderm it either delaminates as a sheet of cells from the outer surface of that layer, or arises as a series of hollow, sac-like outgrowths from the endoderm called enterocoels or gut-pouches. When formed by the latter method the mesoderm from the beginning contains cavities which were originally parts of the primitive gut cavity. In cases where it splits off as solid masses similar cavities appear within it later. Such cavities in the mesoderm become the cœlome or true body cavity. In animals in which the body is segmented or metameric, such as the annelid worms, arthropods and vertebrates, the first evidence of segmentation appears in the mesoblast. In certain embryos a rather ill-defined tissue appears composed of loose cells and called mesenchyme. It may be produced very early, before the true mesoderm, or it may be proliferated from that layer. In general it gives rise to connective tissues.

**Germ-Layer Theory.**—All metazoa, excepting sponges and cœlenterates, exhibit three germ layers, a fact to which great significance has been attached by many embryologists. The sponges are so aberrant in their development that it is impossible definitely to identify their two layers with ectoderm and endoderm; while the cœlenterates, as suggested by Haeckel, may be regarded as a primitive group which has not progressed morphologically beyond the gastrula stage of complexity. The question of the homology of the three germ layers in the other phyla is one which has evoked much discussion and has led to considerable difference of opinion. As comparative embryology became known, the well-nigh universal occurrence of three layers and the general similarity of their respective derivatives naturally led to the assumption of their homology, a generalization known as the "germ-layer theory," though, as stated above, the middle layer differs greatly in its mode of origin in different groups. In nearly all cases, however, the ectoderm gives rise to the epidermis, the lining of the mouth and anal region, the nervous system, and in some invertebrates, to the kidneys. The endoderm, with which from the beginning the nutritive yolk is especially identified, becomes the lining epithelium of most of the alimentary canal and the chief digestive glands and in vertebrates gives rise to the germ cells which later wander into the mesoderm. The mesoderm, the latest layer to appear, is the source of the connective tissues, including the internal supporting hard parts when such are present, the blood and blood vessels, the muscular sys-

tem, the gonads with the germ cells in most cases, and usually the kidney system. The methods by which germ layers become differentiated into their derivative tissues and organs are so varied that limitation of space precludes their present discussion, but it may be stated that common accompaniments of histogenesis are thickening, folding and delamination (splitting) of layers and also localized proliferation of free cells. The assumption of homology of the germ layers in different groups was quite natural, but of late years evidence has accumulated which indicates that many of the developmental resemblances of different phyla are to be interpreted rather as similar but quite independent reactions to like environmental factors; or in a word, as homoplastic rather than truly homologous.

**Nutrition of Embryo.**—Throughout the entire course of development the mechanical effect of food-yolk is very marked, not only in its retardation or prevention of cleavage in certain parts of the egg but in its mechanical effect on the formation of the germ layers and its physiological relation to development of the nutritive system. In general, though there are many exceptions, large eggs rich in yolk develop slowly and the resulting embryos hatch in an advanced state, often with essentially the adult form, while small eggs poor in yolk must early develop some means of securing food and usually in such cases the embryonic period is very brief, the embryo hatching in the form of a *larva*, often totally different from the adult. Such larvæ are especially common among marine invertebrates, in which usually they have the form of minute free-swimming organisms, often with no resemblance to the adult either in form or habit. Examples are the trochophores of annelids and molluscs, the nauplius of the crustacean, bipinnaria of the starfish, etc. In some cases the larva represents only a small portion of the future adult animal, occasionally only a portion of the head precociously equipped with an alimentary system and means of locomotion. These larvæ feed on various micro-organisms and eventually become made over into the adult form by a more or less complete metamorphosis.

**Extra-embryonic Membranes.**—In some animals extra-embryonic membranes are produced which subserve a temporary function in the protection or nutrition of the embryo and which are lost at hatching or at birth. In the higher vertebrates such structures include the chorion, a membrane forming the outer wall of the entire embryonic vesicle; the amnion, a closed water-sac lined with ectoderm and completely enclosing the embryo, and the allantois, an extension outside the body of the urinary bladder which in reptiles and birds and also in the primitive egg-laying mammals known as monotremes spreads its vascular wall inside the chorion close to the porous egg shell and serves physiologically as an embryonic respiratory organ. In the marsupial mammals, such as the kangaroo and opossum, the young are nourished during the very brief period of gestation by "uterine milk," a secretion of uterine glands which the embryo absorbs by means of its vascular membranes, chiefly the yolk sac. Uterine milk is also an important source of nutriment to the embryo even in some placental mammals, where it contains leucocytes and the detritus of

disintegrated cells of various sorts in addition to glandular secretion. The placental mammals are so called because an organ named the placenta is developed, which is essentially composed of villi or vascular tufts developed on the surface of the chorion and supplied with blood vessels by the allantois. These chorionic villi come into intimate contact with the mucous membrane lining the uterus, which becomes profoundly modified during pregnancy, and through their rich vascular supply the blood of the embryo is brought into close osmotic relation with that of the mother, thus permitting the diffusion into the embryonic circulation of soluble foods and oxygen from the maternal blood and at the same time removing carbon dioxide, so that the placenta serves the functions of embryonic nutrition and respiration. It is important to note that there is no admixture of maternal and embryonic blood, the two in all cases being separated by an osmotic membrane. In some mammals the placental villi are minute and scattered over almost the entire chorion, forming what is known as a *diffuse placenta*, as in the horse and pig. In others they are aggregated into a number of brush-like tufts, the *cotyledonary* type, found in most of the ruminants, as the deer, ox, etc. In other cases the villi are limited to a broad girdle forming a *zonary placenta*, as in most carnivora and in the elephant. In insectivores, rodents and most of the primates, including man, a *discoidal* type of placenta is found in which the villi are limited to a single cake-like mass. In many cases, especially the diffuse and cotyledonary types, the villi fit into corresponding crypts of the uterine mucous membrane from which they are drawn at birth without injury. In other cases, the so-called deciduate placenta, the uterine lining becomes greatly altered and its union with the villi becomes so firm that at birth portions of the maternal tissue are torn away with the embryonic placenta. Recent investigation, however, favors the view that even in deciduate types the maternal portion is largely absorbed before full term, so that the placenta at birth is almost wholly of foetal origin. Though the eggs of mammals are very minute and undergo complete cleavage, their development is remarkably like that of the large eggs of reptiles and birds in the mode of germ-layer formation, organogeny and relations of extra-embryonic membranes, and strongly indicates the descent of mammalia from ancestors whose eggs had abundant yolk and underwent partial cleavage. This, indeed, is often cited as one of the classic examples of the persistence of ancestral developmental habit. In this particular case the evidence is confirmed by the occurrence of oviparous habit, large eggs and reptile-like mode of development in the primitive monotreme mammals.

**Bibliography.**—Among numerous works on embryology the following may be mentioned as of especial value: Balfour, F. M., 'A Treatise on Comparative Embryology' (Vols. I and II, London 1885); Ziegler, H. E., 'Lehrbuch der vergleichenden Entwicklungsgeschichte der niederen Wirbelthiere' (Jena 1902); Lillie, F. R., 'Development of the Chick' (New York 1908); Kellicott, W. E., 'General Embryology' (New York 1913); Jenkinson, J. W., 'Verte-

brate Embryology' (Oxford 1913); MacBride, E. W., 'Textbook of Embryology' (Vol. I, Invertebrates, London 1914); Hertwig, O., 'Elemente der Entwicklungsgeschichte: Vertebrates' (5th ed., Jena 1915); Marshall, F. H. A., 'The Physiology of Reproduction' (London 1910).

J. H. MCGREGOR,

Professor of Zoology, Columbia University.

**EMBRYOLOGY, Human.** In the human female, at birth, the ovaries contain several thousand ova. These remain quiescent during the years of childhood, but beginning at puberty and continuing until the climacteric or menopause, ovulation or the dehiscence of ripe ova occurs, usually a single egg escaping from one of the two ovaries at intervals of four weeks. There is without doubt a correlation between the phenomena of ovulation and menstruation, though difference of opinion exists regarding their exact time-relation. During the reproductive life, some 30 years or more, approximately 400 ova may be thrown off, but pregnancy and lactation temporarily suspend ovulation and menstruation. After the climacteric the ovaries, which still contain vast numbers of ova, undergo very gradual degeneration. Maturation, fertilization and cleavage have not been studied in the human egg, but on the basis of studies of the early stages of many other mammals, especially mouse, cat, bat and rabbit, the corresponding conditions in man can be inferred with great probability. Early embryos of monkeys and apes, which in their later stages, where direct comparison is possible, show practical identity with human development, have also supplied important evidence. The human ovum at maturity is spherical, about .17 millimeter in diameter, and is surrounded by a transparent *zona pellucida*, and a mass of follicle cells, the *corona radiata*, and the whole enclosed in a vesicle, the *Graafian follicle*. Ovulation is accomplished by the rupture of the follicle, and the egg thus escaping from the ovary passes into the funnel-like end of the *oviduct* or *Fallopian tube*, being carried along by the cilia which line this structure. In most mammals thus far studied the egg undergoes the first maturation division, producing one polar body while still in the ovary and before rupture of the follicle. Fertilization occurs in the upper portion of the oviduct in case spermatozoa are present, and shortly after penetration of the egg by a spermatozoon the second polar body is extruded. Fertilization in mammals is frequently termed "conception." Judging from conditions in other mammals, including monkeys, the zygote undergoes cleavage in the oviduct while it is being slowly swept along by cilia and reaches the uterus or womb in the stage of the early *blastocyst*, a minute hollow sphere or vesicle of cells with an inner mass of cells adherent at one side. This inner mass is the embryonic mass and from it come all the cells which form the embryo, while the wall of the vesicle, the *trophoblast*, has only protective and nutritive functions, becoming later the outer layer of the *chorion*. At the time when the vesicle reaches the uterus the mucous membrane lining that organ is soft, thick and congested. During pregnancy this membrane becomes profoundly modified and is called the *decidua*. Apparently in consequence of some

# EMBRYOLOGY, HUMAN

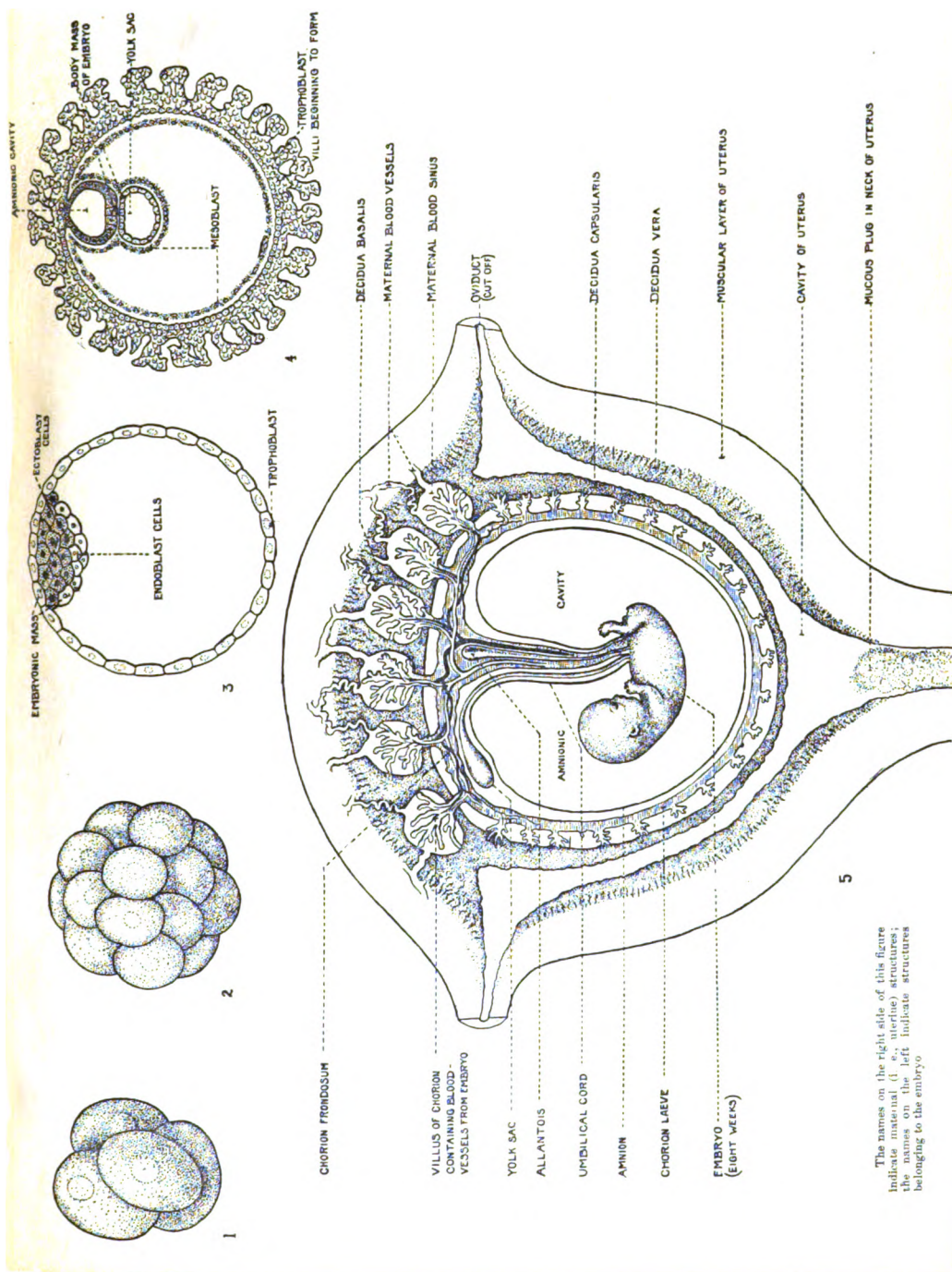

**Fig. 1** Early cleavage. Four-cell stage of monkey. After Selenka. **Fig. 2** Slightly later cleavage of mammalian egg. **Fig. 3** Section of early blastocyst of mammalian embryo. The "Embryonic mass" gives rise to the entire body. **Fig. 4** Section (slightly diagrammatic) of Peters' ovum, one of the youngest human embryos which has been carefully studied. **Fig. 5** Frontal section (diagrammatic) of human uterus and embryo about the end of the second month of pregnancy, to illustrate the relations of the embryonic membranes, and the vascular relations of embryo and mother in the placenta. The placenta is formed by the Decidua basalis and maternal blood vessels, together with the Chorion frondosum.



chemical interaction the embryonic vesicle undergoes "implantation," sinking into the superficial layer of the decidua, which grows over and encloses it, thus separating it from the uterine cavity. Implantation is usually on the posterior wall of the uterus, though it may occur elsewhere, and in abnormal conditions the embryo may become attached in the oviduct, causing a tubal (extrauterine) pregnancy.

The earliest human embryos studied had already become implanted. In one of these (Peters' ovum) the entire blastocyst was about one millimeter in diameter, the embryo one-fifth millimeter, or about one one hundred and twenty-fifth of an inch in length. The age was estimated by Peters at three or four days, but it is now believed to be several days older. The three germ layers are distinguishable and the amnion and yolk-sac are already formed. The chorion is covered with villi which have invaded the capillaries of the uterine mucosa, thus bringing the embryo even at this early stage into nutritive relation with the maternal blood by osmosis. (Fig. 4).

In a slightly older embryo (Graf Spee's embryo) measuring 1.54 millimeters in length, the neural plate or rudiment of the spinal cord and brain is formed. Blood-channels representing some of the chief veins and arteries are distinguishable, and also the two heart rudiments, not yet united in the median line. The chorionic villi already contain blood vessels. The yolk-sac, though quite empty of yolk, is of considerable size, and the allantois has appeared. Several embryos of the third week have been described. At this age the spinal cord and brain form a closed canal, the heart is a twisted tube, and from comparison with other mammals there can be no doubt that the heart-beat is already established. By the 21st day the embryo is four or five millimeters in length, and head, tail, gill-clefts and rudiments of eyes and inner ears are clearly distinguishable. By the end of the first month the arms and legs appear as lateral buds and the rudiments of the face are formed. There is a well-marked tail, and head and tail are so flexed as nearly to meet. Measured from neck to rump the embryo is about one centimeter in length. The yolk-sac has not kept pace with the body and is a small pedunculate vesicle. Practically all the great organs are indicated by the beginning of the fifth week. For example, from the alimentary canal the rudiments of thyroid, thymus, lungs, liver and pancreas have budded out. In general structural plan the embryo up to this stage is rather more like a fish than like the adult human. This is especially true of the blood-vascular and urinary systems.

During the second month growth is rapid, and by the end of this period the embryo is about 30 millimeters in length. Even the layman could now identify it not merely as a mammal but as human, or at least as a primate. The face is now fairly well formed, even to mouth and nostrils, and the external ear is taking shape. The tail diminishes after the sixth week and has almost disappeared by the eighth. Elbow and knee flexures are well marked and hand and foot exhibit digits. The third month witnesses an increasing humanness in the appearance of the embryo — or "fœtus," as it is commonly called after the establishment of its ex-

ternal form. About the 11th or 12th week it becomes possible to distinguish the sex from the external genitalia. Before this time these organs were present but different in development, though sex is actually determined at fertilization and can be distinguished about the end of the first month by microscopic examination of the genital ridges, the structures which later give rise to ovary or testis. About the middle of pregnancy, toward the fifth month, muscular movements of the fœtus become strong enough to be felt by the mother, a fact which has given rise to a vulgar belief that life begins at this period of "quicken-ing" as it is called. About this time the face and most parts of the body become covered by a dense growth of fine hair, the "lanugo." This fetal hair increases for a month or two, but is shed to a great extent before birth. With the growth of the fœtus great changes have taken place in the embryonic membranes, the later conditions of which and their relations to the decidua or uterine mucous membrane are illustrated in the diagram (Fig. 5). It may be stated in brief that the amnion enlarges greatly, becoming adherent to the chorion. The yolk-sac and allantois virtually disappear. The chorionic villi disappear except on the portion of the surface directed toward the original site of attachment, where they persist, forming the *chorion frondosum*, which comes into close relation with the corresponding part of the decidua, and with it forms the *placenta*, the vascular organ by which the fœtus, physiologically a parasite, derives its nourishment and its oxygen from the maternal blood.

Birth occurs approximately 280 days after fertilization, though a fœtus born as early as the seventh month may survive. The average weight at birth is near seven pounds. The fœtus is expelled by involuntary contraction of the uterus, aided by contraction of the abdominal muscles. Rupture of the amnion by muscular pressure precedes birth, and shortly after the child is born the placenta, torn loose by further uterine contraction, is expelled, together with the amnio-chorion. The entire mass is called the "afterbirth." Tremendous physiological changes occur suddenly in the child at birth. Cessation of placental oxygenation of the blood stimulates the lung-breathing reflex. Dilation of the lungs at the first breath brings into service the pulmonary circulation, including the functioning of the left side of the heart, and also effects the closure of the *foramen ovale*, an opening between the two auricles. Certain arteries and veins, hitherto very important, suddenly become non-functional and undergo rapid atrophy. Thus, almost in an instant a fundamental alteration is effected in the respiratory, circulatory and nutritive mechanisms by which the physiologically passive fœtus is transformed into the active breathing and feeding infant.

**Bibliography.**—Many excellent works on human embryology have been published. Among the best textbooks are McMurrich, J. P., 'The Development of the Human Body' (Philadelphia 1907); Bryce, T. H., 'Embryology' (Vol. I of Quain's 'Elements of Anatomy,' London and New York 1908); Keibel and Mall, 'Manual of Human Embryology' (Vols.

I and II, Philadelphia and London 1912), a very exhaustive work; Bailey and Miller, 'Textbook of Embryology' (3d ed., New York 1916).

J. H. MCGREGOR,

*Professor of Zoology, Columbia University.*

**EMBRYOLOGY OF PLANTS.** That phase in the life history designated as the embryology begins within the fertilized egg, but its end is not marked by any such definite feature. In general, the embryo represents the early stages in the development of an individual from the egg. In the ferns and their allies, somewhat later stages, in which one or more leaves are visible to the naked eye, are called sporelings. There is no definite feature to mark a line between the sporeling and the adult plant. In the seed plants, the series is embryo, seedling, adult, with no features to mark the transitions. The difficulty is the same as that in defining baby, boy and man. The early stages in the development of the embryo are fairly well known in all groups from the liverworts to the

inches. (Figures of some of these features may be found under SPOROPHYTE, EVOLUTION OF). In the ferns and their allies, the embryo begins to develop in the same way, forming a spherical mass of cells, but definite growing regions soon appear, marking the root, stem, leaf and foot. The embryo is parasitic upon the gametophyte until the root becomes developed and begins to get nutrition from the soil and the leaf begins to secure materials from the air. When this stage has been reached, we no longer call the young plant an embryo, but a sporeling. In the seed plants, which include the Gymnosperms and Angiosperms, the development of the embryo presents great variation and complexity. In the cycads (q.v.) which represent the lower living Gymnosperms, the fertilized egg does not immediately give rise to a mass of cells, but nuclear divisions, without any separating walls, take place, until there may be as many as 1,000 nuclei lying free in the cytoplasm of the egg (Fig. 1, A). Cell walls then appear at the lower part of the egg (Fig. 1, B). The cells, thus formed, become differentiated into three regions, (1) a group of cells remaining within the limits of the egg, (2) a region of rapidly elongating cells called the suspensor and (3) at the tip of the suspensor some small cells with dense protoplasmic contents (Fig. 1, C). The root, stem, cotyledons and leaves of the embryo come from these small cells, the other two regions being temporary structures which function only during the early development. After the embryo breaks out from the seed and becomes independent, it is usually called a seedling. The eggs of the cycads are very large, reaching one-eighth of an inch or even one-fourth of an inch in length. In the higher Gymnosperms, the eggs are much smaller, in most Pines not more than one-hundredth of an inch in length. In these higher forms there is a constant tendency to reduce not only the size of the egg, but also the number of free nuclei. There are still the three regions mentioned above, but each consists of only a few cells. In a few Gymnosperms, the free nuclear period is entirely eliminated, a cell wall following the first division of the egg nucleus. In the Angiosperms the eggs are still smaller, all being microscopic in size, and in all the cases the first division of the nucleus of the fertilized egg is followed by the formation of a cell wall so that there is no free nuclear stage. Even under the microscope, the eggs of this group look so exactly alike that it hardly seems possible for one to develop into an herb, another into a shrub and another into a tree. We say the course of development is determined by heredity, and those who are satisfied with the mere naming of a phenomenon may be satisfied with this explanation. Although the eggs and embryos are very small, modern technic is so efficient that the embryology is well known from the willows and crowfoots to the sunflowers and orchids. A simple and fairly typical type of embryology is illustrated by the Shepherd's Purse (*Capsella*), a familiar and widely-distributed weed (Fig. 2). The first division of the fertilized egg is transverse (A). Divisions then take place so that a filament consisting of a single row of cells is produced (B); the terminal cell of the row then divides vertically and from the two resulting cells the stem, cotyledons, leaves and nearly all the root

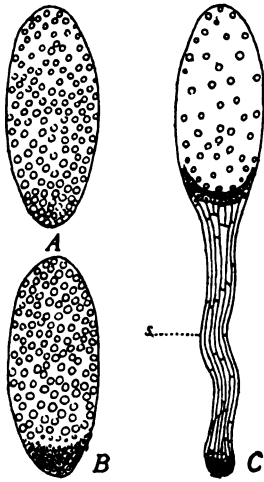

FIG. 1.

highest flowering plants. In the liverworts and mosses, the development of the embryo from the fertilized egg up to the adult stage, and even to the death of the individual, is rather short. The embryo, and even the adult, are small, are parasitic upon the egg-bearing plant (gametophyte), and do not produce any leaves. In the lowest liverworts the egg divides into halves, then into quarters and continues dividing until a spherical mass becomes differentiated into an outer protective layer enclosing a large number of spores. In the higher liverworts and in the mosses, the embryo starts in the same way, but later becomes differentiated into three regions called the foot, stalk and capsule, the latter producing the spores. In the lower liverworts, the adult is a small spherical body not more than one-sixteenth of an inch in diameter; in the higher liverworts and in the mosses the diameter is not much greater, but there is considerable elongation. A couple of inches is rather long; but a few liverworts reach a length of five or six inches and one of the higher mosses is said to reach a length of 10 or 12



are produced (C). The cell in which the vertical division has appeared is generally called the embryo cell, and the rows of cells below it, the suspensor. A second vertical wall at right angles to the first one gives rise to four cells, each of which immediately divides transversely, so that eight cells, apparently just alike, are produced (D). Each of the eight cells now divides, forming a wall parallel to its outer surface (E). These outer cells (dotted in the illustration) continue to divide, but all walls are perpendicular to the surface, so that the result is an extensive layer of cells only one cell in thickness. Since this layer, at maturity, is the epidermis, it is called the *dermatogen*, which means the epidermis producer. In the lower half of the more or less spherical embryo, the four central cells, inside the dermatogen, divide longitudinally (F). The four inner cells resulting from this division (dotted in the illustration) constitute the *plerome* and give rise to

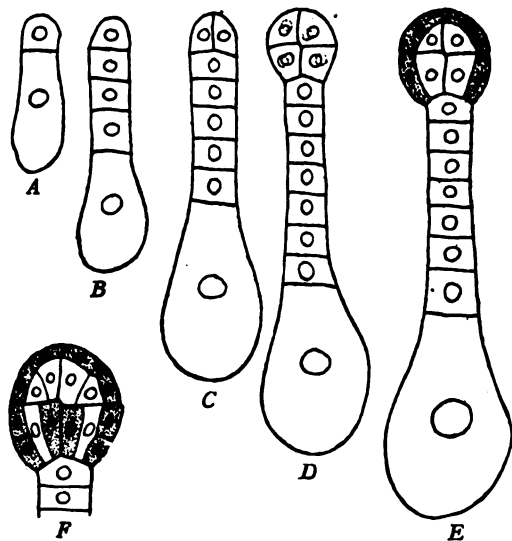

FIG. 2.

the vascular system of the root; the outer four give rise to the periblem which gives rise to the cortex of the root. In the upper half of the embryo, which is to form the stem and leaves, the differentiation into cortex and vascular region takes place much later, after a large number of cells has been produced. Thus there are three embryonic regions, one producing epidermis, another producing the vascular system and the third producing cortex. These three regions, established in the early development of the embryo, are also found in the adult plant.

There are other types of embryology in the flowering plants. Many have no filamentous stage; some have a single, very large suspensor cell, while some have a massive suspensor. In many the differentiation into the three embryonic regions takes place much later; some do not differentiate at all until the seed germinates; while in others, like the bean, the embryo, while still in the seed, has not only cotyledons but well-developed leaves. Some special features of embryology will be found under PLANTS, RECAPITULATION IN, and SPOROPLYTE, EVOLUTION

OF. Consult 'Morphology of Gymnosperms,' by John M. Coulter and Charles J. Chamberlain; 'Morphology of Angiosperms,' by the same authors; 'College Botany,' by G. F. Atkinson; 'Mosses and Ferns,' by D. H. Campbell.

CHARLES J. CHAMBERLAIN,  
*Professor of Cytology and Morphology, University of Chicago.*

**EMBURY, Philip**, Methodist clergyman: b. Ballygaran, Ireland, 21 Sept. 1729; d. Camden, N. Y., August 1775. He joined John Wesley's society and became a local preacher at Court-Mattress in 1758. Emigrating to New York in 1760, he began to preach in his own house in 1766 and two years later erected a chapel on the site of the present "Old John Street Church." Being a carpenter by trade, he worked on the building with his own hands and completed the pulpit, in which he preached the sermon of dedication 30 Oct. 1768. This was the first Methodist chapel of the New World and he has been called "the founder of American Methodism." It was, however, at Camden, Washington County, N. Y., that he did his greatest work, forming there a congregation which grew into the flourishing and influential Troy Conference. Consult Buckley, 'History of Methodism' (Vol. I, New York 1898).

**EMDEN**, Germany, town, in the province of Hanover, on the Ems, near where it discharges itself into the Dollart estuary. Emden has an excellent roadstead and its harbor is connected with this by a canal admitting large vessels. The Dortmund-Ems and other canals connect it with the interior. The town has a Dutch appearance due to its quaint architecture and the dykes which protect it from inundation. The town hall, dating from the 16th century, has a remarkable collection of ancient armor and is one of the finest public buildings in Germany. The town contains also a 12th century church, a museum, art gallery, barracks, a public library, trade and industrial schools, and a deaf and dumb institute. Emden has cable communication with Great Britain, America, and other countries. Its export trade includes grain, dairy produce, cattle, tallow, wool, hides, etc.; and it imports coal, timber, wine and colonial produce. A considerable number of vessels are built here annually; and the manufactures include leather, paper, dairying instruments, basketware, cement, wire ropes, bricks, soap and tobacco. There are also oil-mills, breweries and distilleries. Emden was founded in the 10th century or earlier and in 1433 was added to Hamburg. It became a free city in 1595, and a free port in 1751. In 1806 it was taken by Holland, but nine years later was added to Hanover, which in 1866 was itself made part of Prussia. Pop. 24,038.

**EMELEÉ**, ä-mä-lä, Wilhelm, German painter: b. Buchen, Odenwald, 1830; d. 1905. He first adopted a military career but studied art with Dietz at Munich and later at Antwerp and Paris. His canvases are noted for exact knowledge of military detail and are spirited in conception, his subjects being military. He lived in Vienna after 1861 where he attained great popularity as a painter of equestrian portraits and hunting scenes. Among his works are 'Battle of Stockach'; 'Capture of Heidelberg Bridge in 1799' (1857), purchased by the

Austrian emperor; 'The Fight Near Aldenhoven' (1859); 'The Square of the Battle of Aspern' (1860); 'Capture of Camp Near Farmers'; 'Attack on the English by French Cuirassiers at Waterloo'; 'Battle of Wurzburg' (1867), his best work; 'The Archduke Charles at Battle of Neerwinden' (1872); 'Attack of the Bournernain Division Near Elsasshausen'; 'Battle of Dijon'; 'Meeting of Patrols of Seventh and Fourteenth Corps, Prussian Army, Near Vesoul'; 'Headquarters of 14th Army Corps in Battle of Belfast'; 'Episode of Battle of Wörth'; 'Victory of George II over the French at Dettingen' (1879). His 'Cavalry Encounter near Langenbrück' gained first medal at the Vienna Exposition in 1873.

**EMERALD** (O. Fr. *emeraude*, Gr. *σμάραδος*), a gem of pure green color, often very rich and beautiful. It is a variety of the mineral beryl and is, therefore, a silicate of aluminum and glucinum (q.v.), its green color being due to the presence of a little chromium. It is usually found in nodules or in distinct six-sided prisms of the hexagonal system. It is a little harder than quartz and has a specific gravity of about 2.69. It is not acted on by acids. Many of the most intensely colored and valuable emeralds that we are acquainted with were brought from Peru, the largest from Takowaja, in the Urals, a specimen of which is seen in the 634-pound stone at Saint Petersburg. Most modern emeralds come from the republic of Colombia, which quite supplies the current market. In the United States emerald crystals up to nine inches in length and of rich color have been found in Alexander County, N. C., while extensive mining in Mitchell County, N. C., has yielded beautiful gems and much so-called "emerald matrix." The rarity, rich color, brilliancy and hardness of emerald have made it one of the most highly prized of gems. "Oriental emerald" is green sapphire, "lithia emerald" is hiddenite (q.v.), "Uralian emerald" is demantoid, "Brazilian emerald" is tourmaline (q.v.). See also **BERYL** and **PRECIOUS STONES**.

**EMERALD GREEN**, known also as **SCHWEINFURTH** or **PARIS GREEN**, and by a great number of other names, is one of the most beautiful green pigments. It appears to contain copper, arsenic and acetic acid and is usually regarded as an aceto-arsenite of copper. It is a crystalline powder, which becomes paler by grinding, is not affected by light and air and is insoluble in water, but is decomposed by alkalis. It is employed as a water and as an oil color and is used for tinting wall-papers, though with much less frequency since the danger of that practice has been discovered.

**EMERALD ISLE**, an epithet applied to Ireland, from the freshness and bright color of the verdure, produced by the abundant heat and moisture continually reaching it from the Atlantic. This epithet was first used by Dr. W. Drennan (1754-1820), in his poem entitled 'Erin.'

**EMERSON, Edward Waldo**, American physician, writer and lecturer: b. Concord, Mass., 10 July 1844; son of Ralph Waldo Emerson (q.v.). He was educated at Harvard, where he was graduated in 1866 and from the

medical school in 1874. After retiring from practice he was instructor in art anatomy at the School of the Museum of Fine Arts 1885-1906. He published 'Emerson in Concord' (1888); he edited 'Correspondence of John Sterling and Ralph Waldo Emerson' (1897); 'Centenary Edition of Ralph Waldo Emerson,' annotated (1903); 'Life and Letters of General Charles Russell Lowell' (1907); 'Emerson's Journals,' with W. E. Forbes (1909); joint author with M. Storey of 'The Life of E. R. Hoar' (1911) and many contributions to magazines.

**EMERSON, George Barrell**, American educator: b. Kennebunk, York County, Me., 12 Sept. 1797; d. Newton, Mass., 14 March 1881. He was graduated at Harvard College (1817), and was the tutor in mathematics and natural philosophy there (1819-21). In 1823 he opened a private school for girls in Boston, which he conducted until 1855, when he retired from professional life. He wrote the second part of the 'School and Schoolmaster,' of which the first part was written by Bishop Potter of Pennsylvania. He was appointed chairman of the commissioners for the zoological and botanical survey of Massachusetts, in which capacity he published a 'Report of the Trees and Shrubs Growing Naturally in the Forests of Massachusetts' (1846); and was also the author of 'A Manual of Agriculture' (with C. Flint, 1861) and 'Reminiscences' (1878).

**EMERSON, Luther Orlando**, American composer: b. Parsonsfield, Me., 3 Aug. 1820; d. Hyde Park, Mass., 29 Sept. 1915. He studied music and later taught for eight years in Salem, Mass. He then served as organist and musical director in various churches in Massachusetts, and was the director of about 300 musical festivals and conventions. He published 'The Romberg Collection' (1853); 'The Golden Wreath' (1857); 'The Golden Harp' (1858); 'The Sabbath Harmony' (1860); 'The Heart of Judah' (1863); 'Jubilate' (1866), etc.

**EMERSON, Oliver Farrar**, American educator: b. Traer, Iowa, 24 May 1860. He studied at Iowa College, taking a post-graduate course at Cornell University, where he received the degree of D.Ph. in 1891. After serving as superintendent of schools in Grinnell and Muscatine, Iowa, he was principal of the Academy of Iowa College (1885-88); instructor in English (1889-91) Cornell University, and assistant professor of rhetoric and English philology in the same institution (1892-96), when he took the same chair in Western Reserve University. He is member of the Modern Language Association, American Dialect Society, Simplified Spelling Board, and is a regular contributor to philological papers. He has published 'History of the English Language' (1894); 'A Brief History of the English Language' (1896); an edition of 'Dr. Jonson's Rasselas' (1895); and 'Memoirs of the Life and Writings of Edward Gibbon' (1898); 'A Middle English Reader' (1905); 'Poems of Chaucer' (1911); 'Outline History of the English Language' (1906); and contributions to various philological journals and magazines.

**EMERSON, Ralph Waldo**, American poet and philosopher: b. Boston, 25 May 1803; d.

Concord, Mass., 27 April 1882. The celebration in 1903 of the 100th birthday of Ralph Waldo Emerson served as a meter to mark how wide and deep was the influence which a single original thinker gifted with literary expression can exert at the end of his first century; for there was public recognition of his ethical and poetic genius in every quarter of the globe. Along with this appreciation went also the perception that a distinct Emersonian school of thought had arisen, modified in some degree by the circle of striking writers and talkers—men and women of thought, fancy, imagination and eloquence—who gathered around Emerson early or late in his career and now constitute the group known as the "Concord Authors," or the Concord School of Philosophy. Most of these at one time or another lived in the rural village of Concord in Massachusetts, where Emerson spent a half century of his life. Such were Alcott, Hawthorne, Thoreau, Ellery Channing, Louisa Alcott, George William Curtis, Elizabeth Hoar, Elizabeth Peabody, Julian Hawthorne, J. W. Chadwick, W. T. Harris, John Albee, F. B. Sanborn, F. P. Stearns—all of whom lived for longer or shorter times in Concord; and on the outside of the circle, yet not far away, Margaret Fuller, Theodore Parker, Dr. Bartol, David Wasson, Mrs. Ednah Cheney, Christopher Cranch and John S. Dwight. All these stood in relations more or less direct to Emerson, and were influenced in varying degrees by his fertilizing mind and gentle social attraction. Several of them, as Hawthorne, Thoreau, Channing, Margaret Fuller and Alcott, were as original as Emerson, though less gifted with the qualities that form a school or coterie; and none of them could properly be styled satellites or Emersonidæ although that term has been applied to several of them. Emerson was the eldest born of all these, except Alcott. He was the son of a Boston pastor, Rev. William Emerson of the First Church, which had become Unitarian instead of Calvinistic. Most of his male ancestors as far back as the English Reformation were clergymen, and his middle name, Waldo, was said traditionally to come from one of those Waldenses who incurred the censure of the popes as heretics far away in the Middle Ages. His oldest American ancestor founded the Christian Church in Concord in 1635 (Rev. Peter Bulkeley) and by that line Emerson was related to the noble English family of Saint John, of which was Pope's brilliant friend Bolingbroke. From another clerical ancestor, Rev. William Thompson, through the Cogswells, he was related to Wendell Phillips, Phillips Brooks and other men famous for eloquence; and by another line he descended from a clerical family of Moodys, whose genius verged upon insanity. This last name was perpetuated in Emerson's aunt, Mary Moody Emerson, his father's sister, who had more to do with his intellectual and spiritual training than any other of his early instructors. With this strong clerical bent in his ancestry young Waldo Emerson was destined to the pulpit from his cradle, and was carefully educated in Boston and Harvard College with that view. He entered college early and came under eminent teachers, Edward Everett in Greek, George Ticknor and Edward Channing in literature and Caleb Cushing in mathematics—but for the last-named study he

had no inclination, and did not stand high in general scholarship at his graduation in 1821. He read widely, however, and the discipline of teaching in his elder brother William's school for young ladies at his mother's house in Franklin street, Boston, gave him exactness in Latin, French and Greek. He presently (1823) took up the study of divinity with Dr. Channing and Prof. Andrews Norton, and began to preach sermons in 1827. He spent much time in youth at his grandmother's, who owned the Old Manse in Concord, and there he preached for some months in 1828, during the absence of her second husband, Rev. Dr. Ripley. His own grandfather, Rev. William Emerson of Concord, who built the Old Manse, died as a chaplain in the Revolutionary army in 1776.

The clerical life of Emerson was a distinct era, marked by originality and independence in the young divine. His first and only settlement was at the Second Church of Boston, which had been Cotton Mather's, and was Henry Ware's when Emerson was ordained as a colleague in 1829. He became sole pastor in 1830, and in the meantime had married a delicate young Bostonian, Ellen Louisa Tucker, who died in 1832. In 1833, upon a point of doctrine concerning the rite of the Lord's Supper, in which he found himself at variance with his deacons, he preached a sermon gently setting forth his scruples and resigned his place, much against the wish of his people. But he had been ill and despondent since the death of his wife and the illness of his brother Edward; and a foreign tour was prescribed for him, which broke the continuity of his preaching, although he continued to officiate in pulpits here and there for some six years after his first visit to Europe. Miss Elizabeth Peabody, who had often heard Emerson preach, said at the Concord School of Philosophy in 1883:

From 1834 I never omitted an opportunity of hearing Emerson preach. I sought and obtained leave to read the sermons he had in manuscript. They were all as truly "transcendental" as any of his later writings in prose or verse. If a volume of them could be printed to-day in their own form it would interpret his later revelations, of which they are but a varied expression. From first to last he never shut in his vision of the living God to the limitations of his own or any other individual conception. I once repeated to him the reply of an unconsciously wise and pious woman of the Lexington congregation, when asked why they did not settle an eminent preacher (Dr. Hedge). "Oh, we are a very simple people in East Lexington; we can hardly understand anybody but Mr. Emerson." He did not laugh; on the contrary, with an accent almost pathetic, he replied, "If I had not been cut off untimely in the pulpit, perhaps I might have made something of the weekly sermon."

No doubt he would have made much of it. But what he did was better; he turned the lecture desk into a pulpit, and for more than 30 years preached righteousness there. From 1835, the date of his second marriage, to Miss Lidian Jackson of Plymouth, lecturing was his chief occupation during half the year. His essays were first lectures and were generally given to many audiences before he thought them good enough to print.

His first book, 'Nature,' published in a small edition in 1835, was not a course of lectures, but rather genuine essays, thought out for years, and mostly written out in their final form at the Old Manse, or finished in his own study at the home he made for himself in 1835 at the east end of Concord village, and where he died, 27 April 1882. The book attracted little notice in America or England at first,

and a second edition was not issued until 1849, a dozen years having been required to sell 500 copies. But Carlyle, whom he had visited at Craigenputtock in 1833, and with whom he formed then a strict friendship and corresponded until Carlyle's death, saw its value, and so did Alcott, Hawthorne, Parker, Thoreau and a circle of high-minded women, who became his constant hearers. It now takes rank as the nearest approach to a system of philosophy which he put forth in successive chapters during his whole active life. He planned another and more elaborate work, which he called 'The Natural History of Intellect,' and of which he wrote several chapters, intended to set forth the function and operation of the qualities of the human mind—memory, imagination, reason, volition, etc.—but he never brought it to such completion that it could be published as a whole, either by himself or his successive editors, Mr. Cabot, Dr. Emerson, etc. When invited to lecture on philosophy at Harvard, as he was in 1870, he threw these chapters and copious notes and readings into 18 lectures, two in a week, but the effort was too great for him at his age and in his failing strength, and he could never afterward bring the papers into form for printing. Several of the chapters appear separately; and perhaps some future scholar may combine them with 'Nature' into a single work.

Emerson was actually introduced to noisy public notice by two of his early addresses, which are now printed in the same volume with 'Nature'—his Phi Beta Kappa oration of 1837 and his Divinity School Address of 1838. The first attracted attention and praise, mingled with surprise; the second, from its bold appeal to preachers to revise their theology and meet their hearers with original truths, not with traditional forms of religion, aroused the native intolerance of New England to shrill protest and uncharitable malediction. His own college, of which he was the most illustrious graduate, drew back in timid aversion from thoughts alleged to be revolutionary, and it was not until 1867, 30 years after his first Phi Beta oration, that he was again invited to address the student-body, or to receive any collegiate honor. About the same time (1837-38) he identified himself with the unpopular cause of negro emancipation, with the advanced ideas of Alcott in education, and with several schemes of social reform, which the commercialism of the period viewed with dislike or scornful indifference; and so he alienated another class in the New England and New York communities, who might otherwise have been charmed with his literary skill and his peculiar eloquence. Thus his audiences continued small and his writings had little general circulation, until the gradual education of people in his ideas and his phraseology gave him the hearing that his genius deserved.

Meanwhile Emerson was drawing about him in Concord and Boston, in Plymouth, Salem and other New England towns a circle of friends and a school of thought. The number of these persons was small at first, but their enthusiasm was fervent, and their intellectual and social force was considerable. Prominent among them was Margaret Fuller, a woman of genius who drew other women by her

talent and her sympathies, and who had formed a circle of her own in Cambridge and Boston. Among men, the most prominent for a time was Bronson Alcott, an educational reformer, who had shown insight and eloquence in dealing with the young, but whose talent for conversation was not accompanied by any corresponding gift of expressing himself in writing. Others of the circle were F. H. Hedge, an accomplished student of German literature, afterward distinguished in theology; Dr. Convers Francis, a learned pastor and professor at Cambridge; Theodore Parker, equally learned and more radical in opinion; with younger men like William Henry Channing, James Freeman Clarke, Henry Thoreau, Wentworth Higginson, Ellery Channing, S. G. Ward, Marston Watson of Plymouth, J. Elliot Cabot; and in his own immediate acquaintance, Mrs. Sarah Ripley, the most learned woman of New England, who had married Emerson's uncle, Rev. Samuel Ripley; her brother, George Bradford; Miss Elizabeth Hoar, an accomplished woman, betrothed to Emerson's brother Charles (who had died in 1836), and Emerson's own aunt, Mary Emerson, who at times favored and at times opposed the movement in which her nephew was engaged. This movement presently was called, rather than called itself, "Transcendental"—the term borrowed from the phraseology of German philosophy, but hardly corresponding in New England to the meaning it had in Germany, and indeed used loosely in America with no fixed meaning. Its followers were in fact idealists of various shades and divisions of thought and speculative philosophy, whose organ, the quarterly review called *The Dial*, existing four years (1840-44), became the receptacle of much youthful literature and many earnest essays toward the reformation of society in education, morals and politics. Its first editors were Margaret Fuller and Rev. George Ripley, the founder of the famous community at Brook Farm; but from the first Emerson had great influence in its councils, and ultimately became its proprietor and editor, associating Thoreau with himself in editing it. Hence much of the earlier writing of Thoreau first came out in *The Dial*, as did that of Emerson and Margaret Fuller and Theodore Parker. For this review Emerson wrote the introductory essay, as he did in December 1847 for a kindred venture, the *Massachusetts Quarterly Review*, in which Parker and Elliot Cabot were frequent writers. In these two brief essays must we still look for a characterization of the so-called transcendental movement, so unimportant in its first appearance, yet so momentous afterward in determining some of the chief results of the Civil War of 1861-65. In *The Dial* Emerson spoke of it as "the progress of a revolution," and such it proved indeed to be. He added:

Those who share in it have no external organization, no badge, no creed, no name. They do not vote or print, or even meet together. They do not know each other's faces or names. They are united only in a common love of truth and love of its work. . . . Without concert or proclamation of any kind, they have silently given in their several adhesion to a new hope; and in all companies do signify a greater trust in the nature and resources of man than the laws or the popular opinions will well allow.

Seven years later, approaching the same topic from another point of view, and with more experience of his countrymen, Emerson said in

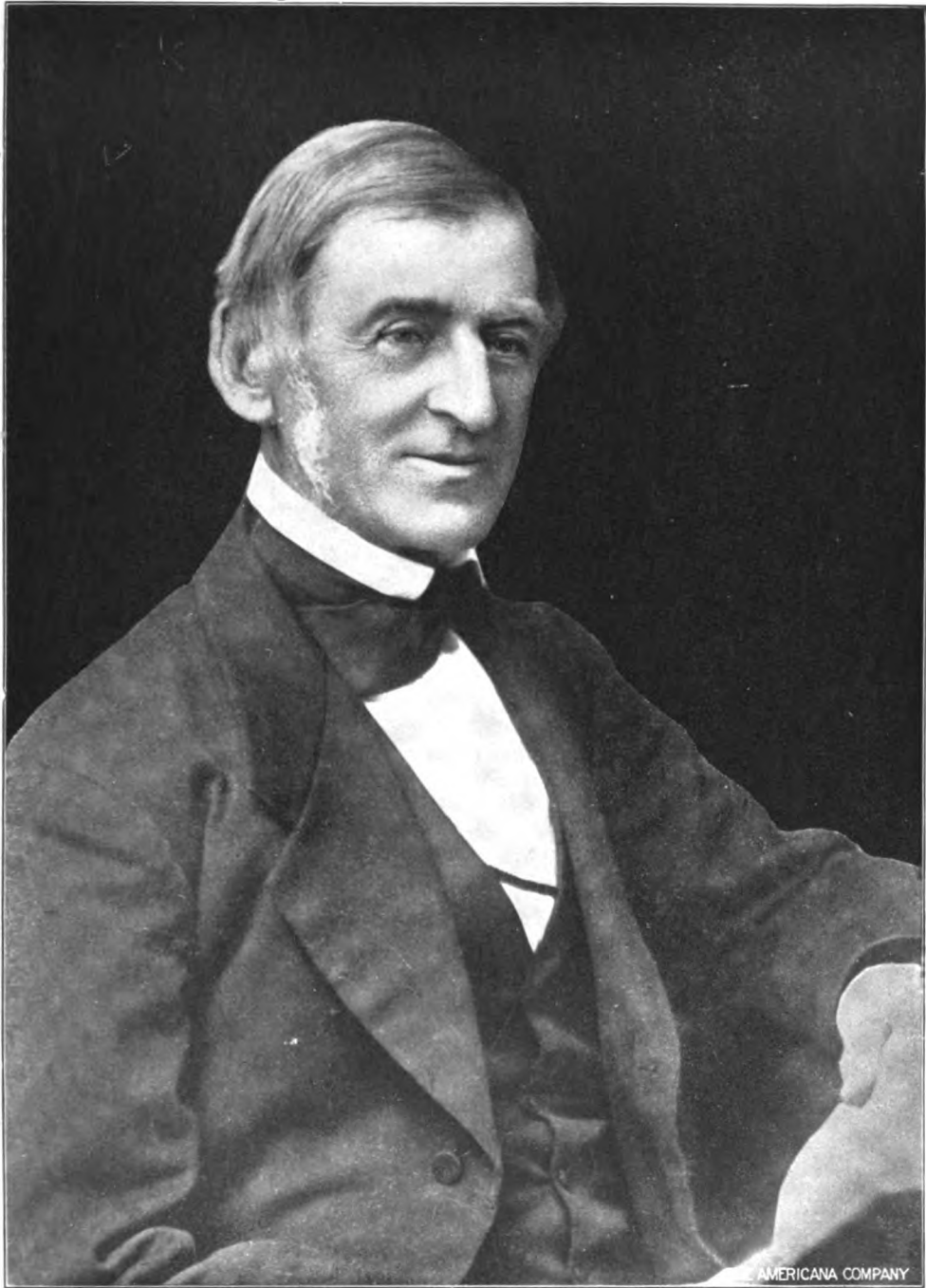

**RALPH WALDO EMERSON**



the first number of the *Massachusetts Quarterly*:

The aspect this country presents is a certain maniacal activity, an immense apparatus of cunning machinery, which turns out at last some Nuremberg toys. Has it generated, as great interests do, any intellectual power? One would say there is nothing colossal in the country but its geography and its material activities; that the moral and the intellectual effects are not on the same scale with the trade and production. . . . It is a poor consideration that the country wit is precocious, and, as we say, practical; that political interests on so broad a scale as ours are administered by little men with some saucy village talent; by deft partisans, good cipherers, strict economists, quite empty of any superstition. . . . The state, like the individual, should rest on an ideal basis. As soon as men have tasted the enjoyments of learning, friendship, and virtue—for which the state exists—the prizes of office appear polluted, and their followers outcast.

The profound discontent so manifested, yet lightened by an ideal hope of better things, was working in the mass of the Northern people, as well as in this small nucleus of Platonists and agitators of New England, New York and Ohio. While *The Dial* had to perish for want of subscribers, the *Tribune* of New York rose up to more than fill its place; and Margaret Fuller, Thoreau, George Ripley and George William Curtis found Greeley ready to give them a hearing in his daily and weekly newspaper, which had readers everywhere. It reported Emerson's lectures, the sermons of Parker and printed the higher criticism of Ripley, Dana and Margaret Fuller. Political parties began to be formed on ideal issues and courageous minorities began to grow into triumphant majorities here and there.

In this escape out of the ideal into the practical Emerson rather unwillingly found himself involved. He began to be popular, and his books, which up to 1850 had scarcely paid for the cost of publishing them, became a source of moderate income. He had followed up the publication of essays in *The Dial* by the issue in 1841 of a volume selected from his earlier lectures and essays, a second series in 1843, a collection of his orations annexed to a reprint of 'Nature' in 1849, and in 1850 his most effective book for European recognition of his high quality, the 'Representative Men.' All these books had been lectures mainly, though much changed in publication, as may be seen by reading the omitted passages cited in the 'Notes' to Dr. Emerson's 'Centenary Edition' of his father's books, issued in 1904. And by 1850 Emerson had become a widely-sought lecturer and went as far west as Galena and Saint Louis, though practically shut out of the slaveholding States by his pronounced anti-slavery opinions which began to be made public by him in 1844. This wider hearing as lecturer was needful to him now pecuniarily, for his small fortune which had made him independent since 1832 had become involved in railroad speculations by the ambition of a classmate at college and yielded him little revenue for years. The way had been prepared for his extended reputation in England and on the continent by his visit there in 1847-48, when he lectured extensively in England and Scotland under arrangements made for him by Alexander Ireland of the Manchester *Guardian* and by his friend Carlyle and others in London. He had even aroused the envy of Mrs. Carlyle by his welcome in England among the aristocratic circle to which he had access through his friends

George Bancroft and Charles Sumner, as well as by the simple dignity of his own manners, which admitted him everywhere in the exclusive society of great cities. On this visit he saw something of the French Revolution of 1848, and made acquaintance in England with Arthur Hugh Clough, Matthew Arnold, Froude and others of the rising young men in literature, as well as the older men of letters whom he met at the breakfasts of Rogers and in the circle to which Carlyle, long resident at Chelsea, belonged.

Emerson had ever been more forward to publish his friends' books than to hasten to the press with his own. The first edition of 'Sartor Resartus' in America was introduced by him in a preface, and he took charge later of American editions of the 'French Revolution' and the earlier essays of Carlyle, by all which the author received from sales in America before 1842 about \$1,000, which he assured Emerson was more than he had then got from his books (not his review articles) in Great Britain. Emerson also edited the first edition of Jones Very in 1839, and promoted the earlier volumes of Ellery Channing and Thoreau from 1840 to 1854, when Thoreau issued the second of the only two volumes published in his lifetime. Altogether, for Carlyle, Margaret Fuller and his other friends, he had caused to be printed three times as many volumes as appeared of his own writing during the 20 years after his second marriage in 1835. In 1852, while in the midst of his lecturing popularity, he paused at Buffalo, N. Y., from one of his extended tours to urge on his friends at Plymouth to gratify the ambition of Ellery Channing, who would figure as a lecturer as well as a poet. Emerson wrote then to Marston Watson, the "Plymouth Evelyn," as Alcott styled him, thus (4 Jan. 1852):

Mr. Scherb is a very proper person to take a part in your series of Sunday lectures, and will gladly do so. One other person I should like well to have engaged, my friend Ellery Channing. But I dare not quite say he has any lecture for your purpose, until I hear his lecture on the 'Future.' Both the others of his three I have heard; and though they are full of wit and criticism or sarcasm all round the compass, he needs practice and pruning. I am sorry on his very account to leave home just now; for I wish more that he should lecture than that I should.

As a poet Emerson had been slightly known to his youthful associates in college and elsewhere, and in 1834 he had been invited to write the customary poem for the Phi Beta Kappa anniversary at Harvard and did so. But he was dissatisfied with it and for some years after did not publish verses. In 1837 he sent to his friend J. F. Clarke at Louisville, Ky., for printing in the *Western Messenger* of Louisville and Cincinnati three poems of his earlier composition, and he continued to print others in *The Dial*. In 1846 he collected these and others in a small volume, printed in Boston and London in 1847, and he issued another volume, largely made up from contributions to the *Atlantic Monthly*, in 1867. His son has added many poems and fragments in the final edition, so that it is now possible to judge of Emerson as poet by a perusal of all that he wrote in metre. At first his verse attracted little attention, except by parodists, who viewed it as something comical and to be satirized; this he had expected, for it had happened with his

prose also. But even those who admired and quoted his poetical prose were rebuffed by his irregular and difficult verse, and only some 20 years after the volume of 1847 did it begin to be recognized that here was a philosopher putting his thought into oracular verse, some of which was becoming proverbial, as oracles are wont to be. Since 1884, when at the summer session of the Concord School of Philosophy this feature of his poetry was set forth, it has become a fashion to interpret it in readings; and the essence of his deeper philosophy is best given in his verse; a key to the whole Emersonian theory of the universe being found in the oracular 'Sphinx' of the first 'Poems,' where it stands at the beginning as befits a key. Besides this philosophic quality there is also much of the high literary character in single poems devoted to love, friendship, patriotism and the cause of liberty.

Had it been predicted in 1847, when Harvard professors were scoffing at Emerson's verse and declaring his philosophy unintelligible, that 60 years later Harvard would be teaching philosophy in a spacious hall named for Emerson and built in part by the contributions of his followers and friends, the prophecy would have been classed with almanac presages of the weather. Yet that very thing has happened and happened partly in consequence of the 10 years' continuance, from 1879 to 1888, of the summer school of philosophy and literature just mentioned. This school carried out an early dream of Emerson and Alcott, who both took part in it till Emerson's death in April 1882 and Alcott's stroke of paralysis in the following October. It brought together speculative men of different schools, all in their way idealists, and it raised into prominence Emerson's share in quickening and deepening philosophic ideas in America.

Emerson had published his 'English Traits,' a masterly summary of English history and character, in 1856; in 1857 he became a leading writer for the new *Atlantic*; in 1860 published the 'Conduct of Life'; in 1864, 'Society and Solitude'; in 1874 a selection of poems (omitting his own) called 'Parnassus'; and in 1876 'Letters and Social Aims,' edited by his subsequent biographer, Elliot Cabot. During the Civil War he was a frequent orator for the Union and emancipation, and his political speeches have been posthumously collected in a volume of 'Miscellanies,' published in 1883 and enlarged in the Centenary edition. A volume of 'Lectures and Biographical Sketches' (1883 and 1904) gives his posthumous lectures and personal tributes, and a final volume (1893 and 1904), 'Natural History of Intellect,' gives others, and a general index, long needed.

The classification of topics in these later books does not well agree with the titles, and there are still other volumes promised from Emerson's journals and letters, although these have been much drawn upon in notes to the 12 volumes already issued. It remains for some future editor to arrange the writings with a better regard to their chronological sequence, since the estimate of Emerson as a writer depends somewhat on the observed growth and decline of his powers as in the analogous cases of Plato and Goethe.

It is in the class with these two world-renowned authors that Emerson will stand

hereafter. Less copious and less imaginative than either Plato or Goethe, he is not less original than they, and his expression of profound thought and ethical truth was guided by a taste often better than theirs. Much mannerism and many repetitions are found in his books as in theirs; many apparent inconsistencies also, as with them. But these last grew out of the development of his thought and his increasing perception of the complexity of the two worlds, Nature and Man. Of his many biographers and critics few have fully comprehended him—they furnish material for final judgment rather than a statement to satisfy future readers. The best, in this view, are Elliot Cabot and Dr. Emerson, to whom the world is indebted for much material drawn from the manuscripts and not found in type elsewhere.

Emerson's health and vigor failed after the partial burning of his house in 1872, and his last tour abroad, in 1872-73, did not restore him. He continued active for years, though withdrawing more and more from publicity by reason of his failing memory. His virtuous and serene nature remained unshaken by these accidents of mortality, and his final illness, though pathetic from his anxiety to avoid burdening others, was short and hardly afflictive. His wife and three of his four children survived him—Mrs. Emerson, the mother of all, dying in 1892 at the age of 90. His descendants are numerous, by various names; his friends are numberless, for he never had a personal enemy and he inspired affection almost as much as admiration. See EMERSON'S ESSAYS; TRANSCENDENTAL PHILOSOPHY.

**Bibliography.**—Memoirs of Emerson in various forms began to appear even before his death in 1882, the first good one being by G. W. Cooke (Boston 1881), 'Ralph Waldo Emerson, His Life, Writings and Philosophy'; followed in 1882 by Alcott's last book, 'An Estimate of Emerson's Character and Genius in Prose and Verse.' In 1883, supplemented in 1885, appeared 'The Correspondence of Carlyle and Emerson,' edited by Prof. C. E. Norton, containing much not found in any biography of either. 'The Genius and Character of Emerson, Lectures at the Concord School of Philosophy' (Boston 1884) contains estimates by 12 or 15 literary and philosophic friends. The authentic biography is 'A Memoir of Ralph Waldo Emerson' by J. Elliot Cabot (Boston 1887); the best brief biography is Dr. Richard Garnett's 'Life of Ralph Waldo Emerson' (London 1888). Dr. E. W. Emerson's 'Emerson in Concord, a Memoir' (Boston 1889), is a supplement to Cabot's memoir, dealing chiefly with Concord incidents. The largest recent addition to our knowledge of Emerson's life and writing is found, however, in Dr. Emerson's 12 volumes of the Centenary edition of 1904, containing at least 1,000 pages of new matter, with many dates and incidents not elsewhere recorded (Boston 1903-04). Consult also 'Letters from Ralph Emerson to a Friend,' edited by C. E. Norton (ib. 1899); Cooke, G. W., 'Bibliography of Ralph Waldo Emerson' (ib., 1908); Howells, 'Literary Friends and Acquaintance' (New York 1900); Eliot, 'Emerson as a Seer' (Boston 1904); Morley, John, 'Critical Miscellanies' (Vol. I, London 1893); Cary, 'Emerson, Poet and Thinker' (New York 1904);



Sanborn, F. B., 'Personality of Emerson' (ib. 1904); Dugard, M., 'Ralph Waldo Emerson; sa vie et son œuvre' (Paris 1907); Harrison, I. S., 'Teachers of Emerson' (New York 1910); Maeterlinck, Maurice, 'Emerson and other Essays' (English trans., ib. 1912). An extensive literature concerning Emerson exists in French, German and Italian, and he is studied to some extent in Scandinavia, Russia, Greece, Persia and India. The autobiographies of M. D. Conway and A. D. White (1904-05) contain something on these points.

F. B. SANBORN,  
*Author of 'Life of Emerson.'*

**EMERSON'S ESSAYS.** In 1841 Emerson published a volume which he called simply 'Essays.' When he published another volume of the same kind he called it 'Essays: Second Series.' So these two books—the First and Second Series—may properly be called 'Emerson's Essays.' The name, however, may also be taken to cover all of Emerson's work, for although his later volumes, which were generally collections, often had lectures as well as essays, there was no very striking difference between the two forms. Emerson usually wrote as if he were speaking to some one, so that his essays always have the spoken tone; and in the actual lectures which he really delivered, he gave his thoughts much the same turn as if he were writing a book. The 'Essays: First Series' are, however, both in thought and expression the most characteristic thing Emerson ever did. In the matter of style 'Emerson's Essays' are like Bacon's (q.v.) in one way; they are series of reflections and meditations rather than finished treatises. If Emerson writes on history or on art, we are not to expect a systematic account of the subject, complete within the range allowed by its length; we have something very different. While the course of thought is not rambling or disconnected, yet the essay makes its impression chiefly by the sense and meaning of each idea as we come to it, by the illustrations or the figures; by the interest of each element, in short, rather than by the round of completed thought which it presents. This kind of expression has one great advantage at least, for it gives us Emerson's thought with the utmost sincerity and genuineness and permits him to say exactly what he wants to say and exactly as he wants to say it. His method of writing aided in this effort; he used to write down his thoughts day by day in a 'Journal,' and when he wrote an essay on any subject he would gather up whatever he had said on the matter at any other time and use it. His 'Journals' have relatively little as to his goings and comings about Concord or about the house, but they are very full of what he was thinking about. And his thoughts were very likely to be not about everyday things, but about larger questions and the philosophies of life. One finds in the 'Essays,' then, the real essence of Emerson's thought—sincere, original, independent, undistorted, unadorned, unmingled. Here we have, not merely what he might think on sitting down to write, but the sum and substance of his thinking on the matter, as it had for years simmered and distilled in his mind till it left the pure and concentrated essence. Thus his writing has a very personal quality,

although there is none of the gossipy character which we often think of as belonging to the personality of the essayist. It is Emerson himself, so intent on his thought that we forget that it is Emerson. As to what the thought is, that will be better found in the article on Emerson. It may be said here, however, that Emerson was interested in philosophy in its broad sense, namely as the knowledge of himself and the universe that enables a man to get the best out of life. Two comments may be quoted: one by Lowell from 'My Study Windows' who said of Emerson's later lectures that even if the meaning were not always clear, one always felt that something beautiful had passed that way; and the other by Matthew Arnold in 'Discourses in America,' that whatever Emerson might be as poet and philosopher, he was pre-eminently the guide and companion of those who wish to live by the spirit. The 'Essays' and 'Journals' may be compared in the recent authorized editions edited by Edward Waldo Emerson and Waldo Emerson Forbes.

EDWARD E. HALE.

**EMERTON, Ephraim,** American historian: b. Salem, Mass., 18 Feb. 1851. He was graduated at Harvard 1871 and studied in Leipzig, becoming instructor in Harvard 1876, and professor of ecclesiastical history there 1882. His works include: 'Synopsis of History of Continental Europe'; 'The Study of Church History'; 'The Practical Method in Higher Historical Education' (1885); 'An Introduction to the Study of the Middle Ages' (1888); 'Medieval Europe' (1894); 'Desiderius Erasmus'; 'Heroes of the Reformation'; 'Sir William Temple und die Tripleallanz vom Jahre, 1668'; 'Unitarian Thought' (1911).

**EMERTON, James H.,** American naturalist and illustrator: b. Salem, Mass., 1847. He is the illustrator of Packard's 'Guide to the Study of Insects'; Scudder's 'Butterflies of North America'; Verrill's papers in 'Reports of the United States Fish Commission' (1884); and Minot's 'Embryology.' He is the author of seven papers on "New England Spiders" in the 'Transactions' of the Connecticut Academy; 'The Structure and Habits of Spiders' (1878) and 'Common Spiders of the United States' (1902). Emerton constructed anatomical and zoological models for museums at Cambridge, New Haven, New York and Washington.

**EMERY, Henry Crosby,** American economist: b. Ellsworth, Me., 21 Dec. 1872. In 1892 he was graduated at Bowdoin and later studied at Harvard, Columbia and Berlin. From 1894 to 1900 he was instructor and professor of political economy at Bowdoin and from 1901 to 1909 was professor of political economy at Yale. In 1909 he was made chairman of the United States Tariff Board, but returned to his chair at Yale in 1913. He has written 'Speculation on the Stock and Produce Exchanges of the United States' (in 'Columbia University Studies' (1896)); 'The Tariff Board and Its Work' (1910); 'The Work of the Tariff Board in Connection with the Cotton Industry' (1911); 'Politician, Party and People' (1913); 'Some Economic Aspects of War' (1914).

**EMERY, John Runkle,** American jurist: b. Flemington, N. J., 6 July 1842; d. Morris-town, N. J., 30 Jan. 1916. He was graduated

at Princeton in 1861 and at the Harvard Law School 1864. He was admitted to the New Jersey bar in 1865. He was vice-chancellor of New Jersey from 1895 to 1 Jan. 1916, when he retired under the veteran retirement act.

**EMERY, Stephen Albert**, American musician: b. Paris, 1841; d. 1891. He studied at Leipzig where among his masters were such lights as Hauptmann, Plaidy and Richter. He removed later to Dresden and continued his studies under Spindler. Shortly after his return to America he became instructor at the New England Conservatory in Boston. He was three years in this position when he became professor of harmony and counterpoint at the newly founded College of Music of Boston University. He wrote pianoforte pieces, songs, string quartets and textbooks on pianoforte playing and the elements of harmony.

**EMERY**, an impure variety of the mineral corundum (q.v.), reddish brown, black, blue black or gray in color and next to the diamond the hardest mineral known but is not crystallized. It consists of nearly pure alumina (65 to 75 per cent) and oxide of iron and a small amount of silica and water. Emery occurs in large boulder-like masses, closely resembles a fine-grained magnetite ore in texture and is often mistaken for it. In its native form its value as an abrasive has been known from the earliest times and many references are made to it in books by Greek authors. Then as now it was used in cutting and polishing jewels and intaglii in the sculpture of statuary from the harder rocks and in polishing marble. It was undoubtedly used by the Egyptians and there are many evidences of the use of it or as hard a substance in the manufacture of prehistoric stone implements.

As now used, in its pulverized form, it is one of the most useful substances known to the arts. The rock is broken in powerful crushers and stamping-mills and separated into powders of varying degrees of fineness by screens or by elutriation. These powders, varying from particles one-tenth of an inch in diameter to the finest flour, are sprinkled with water or oil upon the lead wheel of the lapidary, or spread upon wood, paper or cloth to which a thin layer of glue has been previously applied; or as has been found to be its most effective application, mixed with various adhesive substances and molded into solid wheels. Emery-stones of various shapes and sizes are also made in the same manner.

Emery-wheels are now made up to 36 inches in diameter and from four to six inches in thickness and in every variety of coarseness from rough shapers to fine polishers for brass and steel. The cementing material is usually a secret with the manufacturer and upon this and upon the quality of emery used depends the cost and the subsequent life and usefulness of the wheel. Properly mounted and turned at a proper speed it is our most effective cutting tool, tearing its way rapidly into chilled castings that the best file will not cut, or taking the teeth instantly off the hardest file. Special points to be observed are uniformity of texture, that the wheel may wear away evenly under use; carefully fitted bearings, that there may be no vibration under the high speed at which it is run;

the wheel must not be fitted closely to either mandrel or flanges, lest expansion by heat burst the wheel; and the cementing material of the wheel must be able to resist the tendencies to centrifugal disruption and to melting under the heat generated by its friction with the object being cut. Its effective speed must have been determined and tested and the degree of pressure with which the work is to be applied must likewise be ascertained. Emery wheels that have become misshapen through use are turned true by various special contrivances, all of which must have a cutting edge of rough diamond. Wheels are often shaped for special work in the same manner.

The present supply of emery is chiefly from the island of Naxos and from near Smyrna, Turkey. A small amount is mined near Chester, Mass., and Peekskill, N. Y., and it is found in insignificant quantities elsewhere in the United States. Corundum and precious sapphire have been found in Georgia and North Carolina. Consult Merrill, 'Non-Metallic Minerals' (New York 1910) and Pratt, 'North Carolina Geological Survey' (1905).

**EMERYVILLE**, Cal., city in Alameda County, on San Francisco Bay, near Oakland, on the Atchison, Topeka and Santa Fe Railroad. It has large stockyards, packing-houses, iron foundries, paint and rubber works, cracker factories and fertilizer plants. Shell Mound Park, so named from an Indian mound, is the most noteworthy feature. Pop. 2,613.

**EMESA**, an ancient town, now called Hems. See HEMS.

**EMETIC**, any agent used to induce vomiting. In medicine the emetics that are used are now few in number. The main object to be attained by their use is to empty the stomach of irritating or poisonous contents. As most emetics act strongly on the sympathetic nervous system, they also cause muscular relaxation, dilated arteries and a sense of weakness, amounting at times to collapse. Emetics are usually classified as local or as systemic — those acting directly on the stomach walls, such as lukewarm water, mustard, alum and the more violent corrosive metallic salts, or those, as copper sulphate, whose influence is exerted on the central nervous system, after first being absorbed into the blood. Of these tartar emetic, ipecacuanha and apomorphine are examples. Emetics should be given with caution. In children particularly the stronger emetics often cause great prostration and if a child be suffering from a disease that causes heart weakness, such as diphtheria, emetics are not advisable. In cases of poisoning emetics should be promptly given, but washing out the stomach by means of a flexible rubber tube is preferable. It is sometimes justifiable to give emetics when there seems to be danger of asphyxiation from retained mucus in the bronchial tubes. The relaxation following emesis is sometimes remarkable. See TOXICOLOGY.

**EMETINE**, an alkaloid occurring in ipecacuanha and constituting its chief active principle. It can be extracted from ipecacuanha by moistening the finely powdered root with ammonia and extracting with alcohol. From the total alkaloids so isolated, emetine is separated by extraction with ether in the presence

of alkali. Its chemical formula has not been established with certainty, but is considered to be  $C_{12}H_{16}O_4N_2$ . Emetine is sparingly soluble in water and in ether, though it dissolves readily in alcohol, chloroform, carbon disulphide and various essential oils. It is colorless, but is turned to a yellow by the action of sunlight. When taken internally in considerable doses it acts as a powerful emetic, to which circumstance it owes its name.

**EMEU.** See EMU.

**EMIGRATION**, the removal of the population of a country or region for the purpose of settling elsewhere. Within the United States the movement of population from the Eastern States to the Western, or from the Northern to the Southern is properly termed emigration, but no statistics are kept as to such movements. The removals from the United States to foreign countries, however, are recorded by the Commissioner General of Immigration and embodied in his annual report to the Secretary of Labor.

In the United States two classes of emigration are recognized: first, the flow of aliens who came into the country as immigrants back to their native lands; second, the emigration of United States citizens to other countries.

For the fiscal year ended 30 June 1917 the departing emigrants included in the first class numbered 66,277—a figure which must be compared with those of previous years to gain a fair estimate of emigration under normal conditions. In 1915-16 the number was 129,765; in 1914-15, 204,074; in 1913-14, 303,338; in 1912-13, 308,190; in 1911-12, 333,262—the largest record for any one year. The influence of the war is readily noticeable. Of the total alien emigration for the year 1916-17, 15,924 were women and children. The chief occupations of the 38,649 men who emigrated were as follows: laborers, 24,801; mechanics, 5,700; servants, 4,005; professional men, 1,930; miners, 1,049. The destinations of the larger groups of these departing aliens were: British North America, 18,994; Italy, 12,542; Russia, 5,947; West Indies, 5,891; England, 2,798; Spain, 2,491; France, 2,064; Greece, 2,034; China, 1,871; Norway, 1,633; Portugal, 1,353; Ireland, 1,027; South America, 993; Sweden, 969; Mexico, 812.

The number comprised in the second class cannot be determined from the United States records, but as the only considerable emigration of United States citizens is into Canada, the figures must be obtained from the records of the Canadian Immigration Office. From these it appears that 61,389 former residents of the United States entered Canada as immigrants in the fiscal year ended 30 June 1917. It is a significant fact noted by Canadian officials that this immigration from the United States constituted 81 per cent of the total immigration for that year. In addition to this large number admitted, 17,988 residents of the United States who attempted to enter Canada in that year as immigrants were rejected as undesirable. It is of interest to note in passing that the Canadian reports show that since emigration from the United States into Canada began in 1898 and 1899, the number of such immigrants totals 1,178,764 persons—out of a grand total of immigration of about 3,250,000 from

all countries; and about 225,000 other residents of the United States have been refused admission in the same period because of their undesirable character or destitute circumstances. The earlier emigrants were chiefly former Canadians who had settled in the United States, but returned to take advantage of improved conditions. Later there were added to this group numbers of European immigrants who did not become naturalized in the United States. The larger part of the more recent emigration from the United States into Canada has been of American-born citizens who have been attracted by the inducements of the Canadian Provincial land offices and by the great mining opportunities in Western Canada, made available by the completion of the Canadian transcontinental railroads. See UNITED STATES—IMMIGRATION TO.

**EMIGRÉS**, ā-mē-grā', a French term for those who have been compelled to leave their country on account of religious persecutions, as did the Huguenot, for instance, in the 17th century, or for some other causes. The term, however, is now most commonly applied to those Frenchmen, many of them of noble family, who left France at the commencement of the first French Revolution. Princes, nobles and prelates crossed the frontier into Switzerland, Germany and Holland, and even penetrated as far as Italy. Their conduct made the position of Louis as a constitutional monarch untenable, for they were constantly plotting with the enemies of France. Proscription followed: between October 1792 and the dissolution of the convention more than 300 laws were passed against the emigrés and their relatives. The relatives who remained behind were formed into an ostracised class; deprived of civil rights and obliged to live under police supervision, and exposed to all manner of special fines and exactions. In 1796 relatives were on the list of proscribed. Vast interests depended on the maintenance of the laws against them: their property formed part of the security on which the assignats had been issued, and the granting of an amnesty and reclamation would have made the assignats so much waste paper and brought the social fabric to ruin. At the head of the emigrants stood the royal princes of Condé, Provence, and Artois, the first of whom collected a part of the fugitives to co-operate with the allied armies in Germany for the restoration of the monarchy. At Coblenz a particular court of justice was established to settle causes relating to the French *émigrés*. But the invasion of the Netherlands by Dumouriez drove them from these provinces in mid-winter in a deplorable condition, while their number was daily increased by the system of violence and terror carried on in France. The corps of Condé was finally taken into the Russian service, and was disbanded in the Russo-Austrian campaign in 1799. When Napoleon became emperor it was one of his first acts of grace to grant permission to all but a few of the *émigrés* to return to their country, but by the terms of the charter of 1814 they were precluded from regaining either their status or their ancient privileges. During the Restoration period they persistently petitioned Louis XVIII and subsequently Charles X for reinstatement and indemnification, but though

a government grant was made for their compensation, the measure was rendered abortive by the July revolution. One of the largest settlements comprising several thousand acres near Towanda, Pa., was made at the place now called Rummersfield on the Lehigh Valley Railroad in Bradford (and formerly in Luzerne) County. Here, from 1793 to 1800, was a centre of French refinement, to which luxury-loving parties from the coast cities came for the purchase of articles from Paris and students for the language. The place was called Azilum, Asylum or Frenchtown. Consult Murray, 'The Story of Some French Refugees and their Asilum' (1903).

**EMILE.** After all deductions have been made Rousseau's 'Emile' or 'Emilius' (1762) remains our most important treatise on education. It is so, not necessarily because its principles are sound or its logic always convincing, but because it is a clear and unequivocal statement of a theory formulated by one, who whatever his weaknesses as philosopher, was incontestably one of the greatest artists of the 18th century.

Rousseau's artistic instinct led him to cast his work in the form of a romance, as is indicated by the title 'Emile' and it should be considered as such, the story of a lad's progress from infancy to maturity, from helplessness and dependence to complete mastery of self and assurance in independent activity. It is unfair therefore to consider it as a practical manual or guide for teachers, the details of which can be transferred without change to the schoolroom. It was its character as romance, furthermore, that helped give it its astonishing popularity. Rousseau realized that the situation there assumed was most unusual and could not often, if ever, be duplicated in real life. He sought, therefore, to inculcate not so much a practical method of procedure as the principles on which any such method should be based. These principles attach themselves very closely to his general philosophy, and it is by them that his theory of education must stand or fall.

Underlying his treatise we find everywhere the two cardinal Rousseauistic assumptions which are the heart of his doctrine—man is by nature good, society and civilization corrupt his native goodness. For this reason a large part of the work of Emile's tutor is negative, consisting in preventing misleading contacts, and the remainder lies in guiding and directing natural desires and tendencies rather than in inculcating aims, aspirations, or what is generally termed culture. His object is not to teach any traditional body of knowledge, but is entirely utilitarian, directed toward developing a healthy, vigorous, right-minded citizen. He insists everywhere on the *natural*, the *normal* and the favor which these words have since enjoyed in connection with education is sufficient testimony to his influence. As any just criticism of Rousseau's philosophy involves a criticism of his doctrine of education, we refer to the article on Rousseau where his theories are considered more at length.

CHRISTIAN GAUSS.

**EMILIA**, ā-mēl'ē-ā, division of Central Italy, comprising the provinces of Bologna, Ferrara, Forlì, Modena, Parma, Piacenza, Ravenna and Reggio nell'Emilia. The name is derived from the ancient Via Æmilia and was

built by the censor Æmilius Lepidus in a.c. 186. It is a continuation of the Via Flaminia, which passed through these territories. Area 7,993 square miles; pop. 2,740,316. Prior to its inclusion in the kingdom of Italy, in 1860, it consisted of the former duchies of Parma and Modena and the papal Romagna.

**EMIN PASHA**, a'men pash-a, or pash'a (EDUARD SCHNITZER), African army surgeon, governor and explorer: b. of Jewish parents at Oppeln, Prussia, 28 March 1840; d. October 1892. He was educated at Breslau, Berlin and Königsberg, going to Turkey in 1864 and being appointed surgeon in the Turkish army 1865. In 1875 he went to Egypt, becoming surgeon-general of the Egyptian army under General Gordon, who made him governor of the equatorial provinces in Sudan. He made several exploring expeditions, his route surveys extending to over 4,000 miles, and gave to the world much information in reference to the fauna and flora of that region, together with much geographical knowledge. He also showed himself an enlightened ruler, and was strongly opposed to the slave trade. He was cut off from relations with the rest of the world by the insurrection of the dervishes under the Mahdi in 1883, although maintaining his position. The Egyptian government made him a pasha 1887. Rescued by Stanley in 1888 he entered the service of the German East Africa Company in 1890. He went with Dr. Stuhlman to East Africa upon an exploring expedition and was assassinated at the instigation of Arab slave raiders. Consult Schweitzer, G., 'Emin Pasha' (2 vols., London 1898).

**EMINENCE**, as a designation of cardinalitial dignity, is of comparatively recent introduction; it dates from the 17th century. Down to that time the cardinals were addressed by the titles Most Illustrious (*Illustrissimus*), and Most Illustrious Lordship (*Illustrissima Dominatio*); but in 1630 Pope Urban VIII promulgated a decree, drawn up in accordance with a report of the Congregation of Rites, substituting for the previous formulas Most Eminent (*Eminentissimus*), and Eminence (*Eminentia*), respectively. No dignity but a cardinal (or by exception the Grand Master of the Knights Hospitallers of the Order of Saint John of Jerusalem) was to be addressed in this form. Further, a cardinal was to ignore any communication addressed to him in any other form; and any prelate who assumed the title Eminence, or Most Eminent, was made liable to penalties. The title was also applied in the Roman Empire in its later days to the emperors and the highest officials.

**EMINENT DOMAIN**, the power of the State to appropriate private property for public use on payment of just compensation to the owner. A superior right of property subsists in a sovereignty, by which private property may, in certain cases, be taken, or its use controlled for the public benefit, without regard to the wishes of the owner. The highest and most exact right of property is immanent in the government, or in the aggregate body of the people in their sovereign capacity, giving the power to resume the possession of the property, in the manner pointed out by the constitution and the laws of the various States, when the

public good requires it. There seems to be no objection to considering this right, theoretically at least, as so much of the original proprietorship retained by the sovereign power in granting lands or franchises to individuals or corporations, wherever the common-law theory of original proprietorship prevails. Extraordinary and unforeseen occasions arise in cases of extreme necessity in time of war, or of immediate and impending danger, in which private property may be impressed into the public service, or may be seized and appropriated to the public use, or may even be destroyed, without the consent of the owner. The power exists only in cases where public exigency demands its exercise. It makes no difference whether corporeal property, as land, or incorporeal, as a franchise, is to be affected by the exercise of the right. It is part of the constitutional law of the United States that no person can be deprived of his property by eminent domain except it be taken for public use, by due process of law, and for just compensation. The first condition has been held by the courts to include not only public improvements carried on directly by the State, as the construction of docks, fortifications, etc., but also private or semi-public undertakings, as railroad bridges, etc. There exists some difference of opinion as to what constitutes "due process of law." The usual method is by condemnation proceedings, determined by general law. These are instituted before a court of competent jurisdiction, or a referee appointed for the purpose, just as any equity suit. The final step is an order of condemnation and award. The legislature may, however, substitute any other process, provided the owner is given notice of the proceedings contemplated. Just compensation means payment of the full value of the property taken or of any interest therein, whether vested or contingent, present or future. (See *SOVEREIGNTY*; *TAXATION*). Consult Cooley, 'Treatise on the Constitutional Limitations which Rest upon the Legislative Power of the State' (7th ed., Boston 1903); Kent, 'Commentaries on American Law'; Lewis, 'Eminent Domain' (2d ed., Chicago 1900); Mills, 'Eminent Domain' (2d ed., Saint Louis 1888); Randolph, 'Eminent Domain' (Boston 1894).

**EMINESCU**, ē-mēn-ēs'koo, Michael, Rumanian lyric poet: b. Botuschani 1849; d. Bucharest, 27 June 1889. After receiving his education at Vienna and Berlin, he returned to Rumania and was appointed librarian at the University of Jassy. He was for a time editor of *Timpul*, a strong Conservative journal, and the fierceness of political strife would seem to have spoilt his fine poetical genius. He died in a madhouse. His fame rests on his first volume of 'Poems' (1st ed., 1834); they are mostly elegiac, and touch questions political, social, religious and moral; all of his thought being pervaded by the philosophic pessimism of Schopenhauer, who influenced him profoundly.

**EMIR**, ē'mēr, or **AMEER**, ē-mēr' (that is, noble, princely), a title of honor given in the East and in North Africa to those who claim descent from Mohammed and his daughter Fatima. These emirs are found in Arabia, where they are the chieftains of the Bedouins. Their origin, however, is doubtful. In Turkey they

form a kind of hereditary nobility, and wear as a badge a green turban, as Mohammed is said to have done. They have certain privileges, but otherwise no higher claims to civil offices than other Mussulmans. The word emir is also applied to certain offices and employments, for example, *emir hadji*, conductor of the pilgrims to Mecca; *emir-akhor*, commander of the Turkish horse; *emir-bazar*, overseer of the markets; *emir-alem*, the Turkish standard-bearer; *emir-al Umara*, prince of princes. The title *emir-al-mumenin*, commander of the faithful, was borne by the caliphs. In earlier times the title emir was much more generally assumed by nobles and princes of high rank. It was borne, for instance, by the Thaherids and Samanids in Persia, by the Tulunids in Egypt and by the first seven Omniads of Cordova, Spain. There were also Christian emirs in the Lebanon region of Palestine, who represented Mohammedan clans converted to Christianity.

**EMMA**, Adelheid Wilhelmine Therese, queen dowager of Holland: b. Arolsen, Germany, 2 Aug. 1858. She was the second daughter of Prince George Victor of Waldeck and Pymont, and was married 7 Jan. 1879 to King William III of Holland. She is the mother of Queen Wilhelmina of Holland, and was queen regent of the Netherlands after the death of William III 23 Nov. 1890 until 6 Sept. 1898, when her daughter ascended the throne. She took an active interest in charities, especially hospitals for consumptives.

**EMMA**. From the time of its publication in 1816, this has been one of the most highly regarded of the novels that Jane Austen wrote. It is the fruit of matured artistry, meditated observation and ripened judgment. The plot involves rather more strands than is customary in her work, but the main line of action is simple. Emma Woodhouse, the youthful heroine, is much given to matchmaking. Having married off her governess before the opening of the story, she sets herself to bring about other marriages among her friends and acquaintances. But the men and women around her are not mere pawns; they act in unanticipated ways; unsuspected factors alter situations; and in the resulting comedy of errors Emma eventually awakens to the fact that she herself has fallen in love. Difficulties and misunderstandings are smoothed away and she is happily married. The easy, natural development of the action, by means of incidents and conversations so normal in aspect as to conceal the artistry of their conception, is especially noteworthy. Plot, however, is subsidiary to characterization. The book abounds in living personalities: the aggressive, vulgar Mrs. Elton; the valetudinarian father of Emma, with his taste for thin gruel; the immortally loquacious, tender-hearted Miss Bates; the admirable, thoroughly sensible Knightley; and Emma herself. It is one of the triumphs of Miss Austen's art that, despite the writer's fears—"I am going to take a heroine whom no one but myself will much like," she had observed—Emma is one of her most fascinating creations; the girl is fundamentally generous, sincere and affectionate; her obvious faults but serve to make her more richly human and appealing. In recounting the experiences of these delightfully normal but highly individualized char-

acters, the author has presented us with an account of English village life remarkable for vitality, wholesomeness and unassuming insight, related with amused tolerance and unobtrusive irony, in a style easy, limpid and absolutely adequate. The novel is not a complete picture of life. The awe and mystery of the world, the stormy passions of men, have no place here. But what is done is done supremely well. The ordinary occurrences of ordinary lives are transmuted into the pure gold of literature. Consult Howells, W. D., 'Heroines of Fiction'; Cornish, Francis Ware, 'Life of Jane Austen'; Smith, Goldwin, 'Life of Jane Austen'; Scott, Sir Walter, 'Review of Emma' (*Quarterly Review*, Vol. XIV, 188).

GEORGE B. DUTTON.

**EMMANUEL COLLEGE**, founded in connection with Cambridge University in 1584, by Sir Walter Mildmay as a Puritan institution. The chapel was designed by Wren. John Harvard, who gave so liberally to education in America, was from this college. It consists of a master, 16 fellows and 36 scholars. In 1913-14 there were 74 undergraduates.

**EMMANUEL MOVEMENT**, The, so named after the Emmanuel Church, Back Bay, Boston, Mass. The movement was started by the rector of the church, Rev. Elwood Worcester, D.D., and his associate, Rev. Samuel McComb, D.D. Dr. Worcester had been residing in Philadelphia, where he enjoyed the friendship of Dr. S. Weir Mitchell, one of the great nerve specialists of the country. Neither of the leaders of the movement had studied medicine, but Dr. Worcester had not only studied psychology under Wundt at Leipzig but for several years had taught the subject at Lehigh University. Dr. McComb had studied the subject at Oxford University. In 1905 work was begun with a tuberculosis class and in 1906 a similar work was begun "among the nervously and morally diseased." From the first, the movement had the co-operation of several leading physicians. Dr. Cabot of Boston, Dr. Barker of Johns Hopkins University, Dr. Putnam and others discussed before the class such subjects as worry, anger, habit, suggestion, insomnia, nervousness, what the will can do, what prayer can do and similar topics. Patients were given mental treatment along with the reading of Scripture and prayer. For some time the movement attracted considerable attention and the Emmanuel Church had many imitators in nearly all denominations. At the present time it seems to have nearly passed away. Consult 'Religion and Medicine—The Moral Control of Nervous Disorders,' by Elwood Worcester, Samuel McComb and Isador H. Coriah, M.D. (1908); 'Faith and Health,' by Charles Reynolds Brown (1910).

**EMMAUS**, ě-mā'us or ěm'mā-ūs, Palestine, (1) A village, about eight miles from Jerusalem, the place mentioned in Luke xxiv, 13. The exact location of this village is not known; the modern El Kubebe, 60 furlongs northwest of Jerusalem, on the road to Lydda, has in its favor as the location of Emmaus its distance from Jerusalem and the fact that in 1099 A.D. the Crusaders found the name Castellum Emmaus given to the place. Recently the modern Koloniyeh has been favored by expert

opinion as the site of Emmaus. In its favor is cited the evidence of its name to the colonizing of the place and the statement by Josephus that Titus planted a colony of 800 veterans at a village called Emmaus, 30 stadia from Jerusalem. (2) Modern Amwas, the place mentioned in Macc. iii, iv and ix. In ancient times and down to the conquest of the Mohammedans, this Emmaus was a place of importance. Its position, about 18 miles northwest of Jerusalem and near the Roman road from Jerusalem to Jaffa, on the seacoast, made it prominent. It was the capital of one of the 10 toparchies into which Judæa was for a time divided. It was known as Nicopolis after the 3d century. Consult Sanday, 'Sacred Sites of the Gospels' (Oxford 1903), and Schürer, 'History of the Jewish People' (Eng. trans., 5 vols., New York 1896).

**EMMENAGOGUES**, ě-měn'a-gōgz, are agents that stimulate the pelvic organs and are used to bring about a restoration or regulation of the menstrual function if it should be absent or abnormal. Occasionally absence of menstruation is due to anæmia or lack of iron in the blood, in which case taking iron internally, by overcoming the anæmia, restores menstruation and may be thus termed an emmenagogue. More properly speaking, however, the term is applied to such drugs as ergot, quinine and hydrastis. These bring about direct stimulation of the unstriped muscles of the body and hence act most forcibly on the uterus, it being the largest mass of unstriped muscular tissue in the body. Aloes, myrrh and the active cathartics act as emmenagogues by increasing the amount of blood in the large intestine and other pelvic organs, thereby increasing the nutrition of the uterus. Occasionally massage and electrical applications are used to bring about the restoration of the menstrual flow and hence may be included in this group.

**EMMERAN**, or **EMMERAM**, Sa'n't, martyr, bishop of Poitiers: b. the last of the 6th century; d. 653. His feast is kept on 22 September, but the exact date and place of his death is not known. In his own day he was renowned for his piety and learning. His biographer says of him "For his great learning and sanctity he was chosen bishop of Poitiers in the 7th century; he preached the pure maxims of the gospel with indefatigable zeal, without respect of persons." After a time his zeal led him to ask permission to go to Bavaria to preach to the "infidels and idolators." After three years' work in Bavaria he began a journey to Rome. On the way he was assassinated by men who believed false accusations which a wicked woman had made. He is the patron saint of Ratisbon, where he was buried.

**EMMERICH**, ěm'měr-ĭh, Germanv. town in Rhenish Prussia, on the Rhine, five miles northeast of Cleves. It is enclosed by walls and ditches, contains several ancient and modern churches, a gymnasium, ecclesiastical seminary and orphanage, and has manufactures of woolen and linen cloth, hosiery, leather, machinery, oil, soap, cigars, tobacco, etc.; some shipping and a free port, at which an active trade is carried on, chiefly with Holland. Its history dates from the 7th century. In 1233 it came under the dominion of the counts of

Geldern, by whom it was raised to the rank of a city, but in 1402 it passed to Cleves. In 1407 it belonged to the Hanseatic League and is believed to have contained then a population of 40,000. It subsequently shared the fortunes of the duchy of Cleves. Pop. 13,418.

**EMMERSON, Henry Robert**, Canadian lawyer and politician: b. Maugerville, N. B., 25 Sept. 1853. He entered the New Brunswick legislature in 1888 and was Premier of the province, 1896 to 1900, when he was elected to the Dominion House of Commons and was Minister of Railways and Canals in the Laurier administration, 1900-07.

**EMMET, Robert**, Irish patriot: b. Dublin 1778; d. 20 Sept. 1803. He intended to practise law and with that view studied at Trinity College, Dublin, from which, however, in 1798 he was expelled on the ground of exciting rebellion. Subsequently he became an object of suspicion to the government and accordingly quitted Ireland and traveled on the Continent. He interviewed Napoleon and Talleyrand, the former of whom promised aid to the Irish revolutionary movement. He returned to Ireland on the repeal of the suspension of the Habeas Corpus Act. He now became a member of the Society of United Irishmen, whose object was the establishing the independence of Ireland. In July 1803 he was the ringleader in the badly planned rising which had for its object the seizing of Dublin Castle, and in which Lord Kilwarden and several other persons were killed, but which was almost immediately suppressed. Emmet was arrested a few days afterward, tried and executed by the sentence of a special court. His fate excited considerable interest from the circumstance of his attachment to Sarah Curran, daughter of the celebrated barrister. Moore has immortalized his memory in 'O breathe not his name,' and that of Miss Curran in the poem beginning "She is far from the land where her young hero sleeps." Consult Madden, 'Life and Times of Robert Emmet' (Glasgow 1902); O'Donoghue, 'Life' (Dublin 1902); 'Robert Emmet: Causes of the Rebellion' (London 1871).

**EMMET, Rosina**. See **SHERWOOD, ROSINA**.

**EMMET, Thomas Addis**, American lawyer: b. Cork, Ireland, 24 April 1764; d. New York, 14 Nov. 1827. He was a brother of Robert Emmet (q.v.), and being tried for the crime of treason was sentenced to exile. He came to the United States and became a noted lawyer in New York. In 1812 he was elected attorney-general of the State.

**EMMET, Thomas Addis**, American gynecologist: b. Charlottesville, Va., 29 May 1828. He is of a distinguished Irish family. His father was professor at the University of Virginia and his grandfather, after whom he was named, was a prominent leader of the Irish movement for independence in 1798 and after coming to America served as attorney-general of New York. He was a brother of Robert Emmet (q.v.). He was graduated at Jefferson Medical College 1850. He served as physician at the Ward's Island Hospital for Immigrants and established his practice in New York in 1852. He was successively assistant surgeon, after 1862, chief surgeon after 1872, and visiting surgeon after 1900 at the Women's Hos-

pital. He was also consultant of Roosevelt Hospital. He has published 'Principles and Practice of Gynecology' and 'Ireland under English Rule' (2 vols., New York 1903). He is inventor of several special surgical instruments and operations.

**EMMETSBERG, Iowa**, city, county-seat of Palo Alto County, on the Des Moines River, the Burlington and M., the Chicago, Milwaukee and Saint Paul and the Cedar Rapids and other railroads, about 123 miles northeast of Sioux City. It is in an agricultural section of the State and it has several grain elevators. Some of the industries are the manufacturing of butter, cheese, flour, brick, cement and tile works. It contains a fine lake and a Carnegie library and owns its waterworks. Pop. 2,325.

**EMMETT, Daniel Decatur**, American song writer and negro minstrel: b. Mount Vernon, Ohio, 1815. He served in the army, joined a circus company 1835 and formed the first negro minstrel company 1842 with Frank Brown, William Whitlock and Richard Pelham, appearing at the old Chatham Theatre, New York, and later in Boston and in England, where Emmett remained till 1844. He was with Dan Bryant 1854-65, writing the famous song 'Dixie' in 1859. He became a manager 1865, returning to his native town 1878. He was a most prolific song writer and among his productions were 'Old Dan Tucker'; 'The Road to Richmond' and 'The Boatman's Dance.'

**EMMITSBURG, Md.**, town in Frederick County, on a branch of the Western Maryland Railroad, about 45 miles northwest of Baltimore. The town is known chiefly for its two large educational institutions, Mount Saint Mary's Theological Seminary (q.v.), just outside the town's limits, and Saint Joseph's Academy, within the town. It contains also the mother-house and seminary of the Sisters of Charity of Saint Vincent de Paul, from Paris. Emmitsburg was the scene of the labors of Mother Eliza Seton (q.v.) when establishing the Sisters of Charity in the United States. There are about 1,800 sisters working in different parts of the country who belong to this mother-house. The city contains a public library and a museum. Its industries include cattle raising and the manufacture of furniture, brooms and hosiery. Settled about 1757, Emmitsburg received its present name in 1785, was incorporated in 1824, and under a charter of 1911 is governed by a burgess and three commissioners. Pop. 1,054.

**EMMONS, Ebenezer**, American geologist: b. Middlefield, Mass., 1799; d. 1863. He was educated and afterward taught at Williams College, later becoming geologist-in-chief, second district, New York State Geological Survey. He introduced the new Taconic stratigraphic system, not now in vogue. He was made professor of chemistry in the medical college at Albany 1838, and had charge of the geological survey of North Carolina 1858. His works include 'Manual of Mineralogy and Geology' (1826); and 'American Geology' (1856), and the monographs published in the reports of the geological surveys of New York and North Carolina.

**EMMONS, George Foster**, American naval officer: b. Clarendon, Vt., 23 Aug. 1811; d. Princeton, N. J., 2 July 1884. He entered the

navy as midshipman in 1828; was promoted lieutenant in 1841; rear-admiral 1872; and was retired the next year. He was a member of the South Sea exploring expedition under Captain Wilkes in 1838-42; took part in the Mexican War; and during the Civil War captured Cedar Keys, Fla., and Pass Christian, Miss., with 20 prizes, in 1862. He served as captain of the fleet under Dahlgren, off Charleston, 1863; and raised the American flag over Alaska in 1868. He published 'The Navy of the United States, 1775-1853' (1853).

**EMMONS, Samuel Franklin**, American geologist: b. Boston, Mass., 29 March 1841; d. 1911. He was graduated at Harvard, taking post-graduate courses at the Ecole Imperiale des Mines, Paris, and Freiberg, Saxony, Mining School, and was a member of several scientific societies, including the National Academy of Sciences and the Geological Society of America, of which he was president in 1896 and 1903. He was in the employ of the government almost uninterruptedly after 1867 and geologist upon the United States Geological Survey, Colorado division, after 1879. He made a survey in 1870 of Mount Rainier, the loftiest point in the State of Washington. Among his writings are 'Descriptive Geology of the Fortieth Parallel Region' (1877); 'Statistics and Technology of the Precious Metals' (1885); 'Geology and Mining Industry of Leadville, Colorado' (1886); 'Geology of Lower California' (1890); 'Geological Distribution of the Useful Metals in the United States' (1893); 'Progress of the Precious Metal Industry of the United States' (1893); 'Geology of the Denver Basin in Colorado' (1896); 'Ten-mile District, Colorado' (1898); 'The DOWNTOWN District of Leadville, Colorado' (1907); 'Ore-Deposits' (1913).

**EMODIN**, one of the active constituents in *Cascara sagrada* and in other species of the genus *Rhamnus*. Emodin acts as a cathartic.

**EMORY COLLEGE**, an educational institution in Oxford, Ga., founded in 1836 under the auspices of the Methodist Episcopal Church; reported at the close of 1915: Professors and instructors 17; students, 260; volumes in the library, 35,000.

**EMOTION**, a complex mental state intimately associated with our actions and with extensive and often sudden physiological changes. Among the more familiar emotions are fear, anger, hate, joy, love, pity, pride, shame, grief, awe, contempt and surprise. They almost invariably seem to involve all the following factors: (1) an experiencing subject; (2) an object toward which they are directed; (3) a set of coexisting actions and physiological changes on the part of the experiencing subject; (4) the mental representation of a future course of action, together with the intention to pursue or to avoid it; (5) a general pleasantness or unpleasantness. The best-known theory of the emotions is that due to William James and C. Lange. These authorities regard an emotional state as entirely constituted by factor (3), the set of coexistent actions and more especially of physiological changes on the part of the experiencing subject. In their opinion, fear consists in a feeling "... of quickened heart-beats, ... of shallow breathing ... of trembling lips, ... of weakened limbs, ... of

gooseflesh ... [and] of visceral stirrings." Rage is constituted by "... ebullition in the chest, ... flushing of the face, ... dilatation of the nostrils, ... clenching of the teeth, ... [and an] impulse to vigorous action." Each of our emotions is subject to a similar analysis and nothing is found beyond our awareness of an active response to some excitant object.

The consciousness of our own reactions is indeed a factor of the utmost importance in the generation of an emotional state. Whether it is the sole factor is a disputable point. Certain recent experiments as to the nature of the vascular and organic changes characteristic of emotional states appear to tell very strongly against the James-Lange theory. As Prof. W. B. Cannon writes in his 'Bodily Changes in Pain, Hunger, Fear and Rage,' "In terror and rage and intense elation, for example, the responses in the viscera seem too uniform to offer a satisfactory means of distinguishing states which, in man at least, are very different in subjective quality. For this reason I am inclined to urge that the visceral changes merely contribute to an emotional complex more or less indefinite, but still pertinent, feelings of disturbance in organs of which we are not usually conscious." The peculiar marks which separate emotion from emotion cannot always reside in the grosser concomitant actions, for these are by no means invariably present, while on the basis of what Professor Cannon has shown, the visceral aspect of the immediate emotional act is too generalized to serve as a principle of individuation. The main differentiae of the emotions are to be found in the courses of purposive conduct intended by the subject and the shadings of pleasantness or unpleasantness with which the emotional states are tinged. It is not the involuntary organic preparation for flight which makes fear distinct from rage, but the conscious intent to flee; while no state of excitement can be called elation unless it is distinctly and intensely a state of pleasure.

The intimate association between emotion and hedonic tinge demands a more thorough analysis, for it is closely connected with one of the most interesting features of an emotion — its *directedness*. Both pleasure and the most complex emotion may have an object. To be pleased or angry or afraid is usually to be pleased or angry at something, or in fear of something. The relation between the emotion and its object is not one of the simple coexistence of an awareness of the object and the emotion; it is possible, for example, to be conscious of many things and to be annoyed at but one of them. The object need not be the efficient cause of the emotional state — one's annoyance may be caused by indigestion, but directed toward those whom one chances to meet. Furthermore, the object of an emotion does not gain its rank as object by virtue of a place in the focus of attention. One may be annoyed at the buzzing of a mosquito of which he is but dimly aware, while his main attention is directed toward a book which he is reading. It is by no such extraneous means as these that the reference of mental states can be explained. The reference of one experience to another is due to the fact that the unity of the content of the mind is the unity of a system and not the unity of a mere fortuitous aggregate. The definite directions of



pleasure or emotion can only be explained on the basis of the existence at each stage of psychological analysis of some unanalyzed state with a definite reference. However, pleasure and emotion are not themselves simple unanalyzable directed states. From what had already been shown of emotion, it is clear that it involves many undirected experiences of the nature of organic and kinæsthetic sensations or images. Pleasure likewise appears to have the dual aspect of a mass of organic experiences, going to make up what may be called a sense of well-being and of an attribute of other mental states. Now, if we strip all sense of well-being from our pleasure, say, at a dinner, all that remains is an act of bare approval. This approval does not appear to be qualitatively distinct from that involved in an æsthetic judgment, an ethical judgment or a normative judgment of any kind. (See *NORM*). Similarly, active displeasure is apparently composed of a sense of ill-being, accompanied by, and possibly forming a portion of the object of, an act of disapproval. The hedonic tone of an emotional experience thus generally seems to involve: (a) a diffuse organic experience of well-being or ill-being; and (b) an act of approval or disapproval directed toward some definite object. It is almost, if not quite, impossible to think of a case where an emotion involves an act of approval or disapproval of this sort, but where the objects of the emotion and those of the act are distinct. There seems to be no valid objection to identifying the objective reference of the emotion with the objective reference of the act. On the basis of this and of what has been said previously concerning the emotions, it is easy to account for the coexistence of different emotions in the same individual: the physiological excitement characteristic of all emotion is present; but it is accompanied by a background of organic sensations conforming in its entirety neither to that of well-being nor to those of definite ill-being though sensations of both sorts are present; by the approval of certain objects and the disapproval of others; or by the intention of pursuing different courses of conduct with regard to the different emotional objects.

The emotions are clearly indispensable for the propagation of the species, the nurture of young, the protection of the individual in times of danger, and for many other essential needs of the race. They have undergone a strict process of natural selection. Among the emotions showing the deepest and most recent effects of this natural selection are those that form the basis of the moral conduct. In many ways our emotions and their modes of expression show traces of the needs of a more primitive existence—thus a sneer is a rudimentary unflinching of the teeth for combat. (See *ÆSTHETICS*; *FEELING*). Consult Cannon, W. B., 'Bodily Changes in Pain, Hunger, Fear and Rage' (New York 1915); Darwin, C., 'Expression of the Emotions' (London 1873); James, W., 'Principles of Psychology' (New York 1890); Mantegazza, 'Physiognomy and Expression' (tr. London 1904); Ribot, 'Psychologie des sentiments' (Paris 1896); Stout, 'Manual of Psychology' (London 1899).

NORBERT WIENER,

*Editorial Staff of The Americana.*

**EMPALEMENT**, a mode of executing criminals, mentioned by Juvenal, often inflicted in Rome, and still used in Turkey and Arabia. In England the dead bodies of murderers were sometimes staked in this manner, previous to being buried; but the custom was abolished in 1823.

**EMPÁRAN**, *Diego de*, *dē-ā'gō dā ěm-pā-rān*, Mexican writer: b. Puebla, 5 April 1718; d. Ravenna, Italy, about 1807. His book, 'The Jesuits and the Pope' (1746), published soon after entering the priesthood, gained him five years' imprisonment. The year after his release he issued a bitter criticism of Church dignitaries, for which he was deposed from the priesthood and imprisoned in the Castle of Sant' Angelo, but released later. His work was burned by the executioner. His other works include 'The Tombs of Mohammed and Christ'; 'Voltaire and His School'; 'Science and Superstition'; and 'Religion and Hygiene.'

**EMPECINADO**, *ěm-pā-thē-nā'dō*, *Don Juan Martin Diaz*, Spanish patriot: b. Cestrillo de Duoso, Valladolid, 1775; d. 1825. He joined the army at 17, and for his activity in the war against the French in the Peninsula was appointed colonel and later made a field marshal. Losing favor with King Ferdinand VII on account of his action in petitioning him to restore the Cortes, he was thrown into prison, his imprisonment being followed by banishment to Valladolid. Taking part in the insurrection 1820 he saw much fighting, but was captured 1823, cruelly treated while a prisoner and after two years he was stabbed while resisting the executioners by whom he was about to be hanged.

**EMPECINADO, EL**. See *DIAZ, DON JUAN MARTIN*.

**EMPEDOCLES**, Greek philosopher: b. Agrigentum, Sicily, about 460 B.C. His fellow-citizens esteemed him so highly that they wished to make him king; but being an enemy to all political forms which elevate a few above their fellows, he refused their offer, and prevailed on them to abolish aristocracy and introduce a democratical form of government. Aristotle states that he died in obscurity at the age of 60 years, in the Peloponnesus, but there are various legends respecting the manner and place of his death. Empedocles presented his philosophy in a poetical form. His general point of view is determined by the influence of the Eleatic school upon the physical theories of the Ionic philosophers. He assumed four primitive independent substances—air, water, fire and earth, which he designates often by the mythical names Zeus, Hera, etc. These four elements, as they were called, kept their place till modern chemistry dislodged them. Along with material elements he affirmed the existence of two moving and operating powers, love and hate, or affinity and antipathy, the first as the uniting principle, the second as the separating. The contrast between matter and power, or force, is thus brought out more strongly by Empedocles than by previous philosophers. His theory of the universe seems to assume a gradual development of the perfect out of the imperfect and a periodical return of things to the elemental state, in order to be again separated and a new world of phenomena

formed. Of his opinions on special phenomena may be mentioned his doctrine of emanations, by which, in connection with the maxim that like is known only by like, he thought to explain the nature of perception by the senses. He attempted to give a moral application to the old doctrine of the transmigration of souls, his views of which resembled those of Pythagoras. The fragments of Empedocles have been edited by Sturz (1805); Karsten (1838); and Stein (1852). Consult monographs by Lommatsch (1830); Raynaud (1848); and Gladisch (1858); also Windelband, 'Geschichte der griechischen Philosophie' (3d ed., Munich 1912).

**EMPEDOCLES ON ETNA** is a dramatic poem by Matthew Arnold, based on legendary accounts of a Greek philosopher who lived in Agrigentum, Sicily, in the 5th century before Christ. The interest of the drama centres in the philosophical despair of Empedocles and his suicide, which he accomplishes by leaping into the crater of the volcano. Before his death he discourses at length on the consolations of philosophy for the benefit of his friend, the physician Pausanias, who accompanies him part way to the summit. Dramatic relief and contrast are provided by Callicles, a young harp-player, who on the lower slopes of the mountain sings with unshaken faith in the traditional divinities and the eternal freshness and delightfulness of nature.

Arnold first published this drama in 1852, but the volume in which it was contained was withdrawn from circulation before 50 copies were sold. He reprinted fragments of it in 1853, '54, '55, '57, and in 1867 revived it in its entirety at the instigation of Robert Browning. In an interesting preface to a volume of verse published in 1853 he explains both why he wrote the poem and why he withdrew it. He had been attracted to the theme because Empedocles, like Arnold himself, was a troubled spirit wandering between two worlds, one dead, the other powerless to be born—"the calm, the cheerfulness, the disinterested objectivity have disappeared; the dialogue of the mind with itself has commenced; modern problems have presented themselves; we hear already the doubts, we witness the discouragement, of Hamlet and of Faust." He had seized upon this parallelism between his position in the 19th century and that of the Greek philosopher in the 5th century B.C. to express with penetrating power the profound melancholy of religious disillusion which sorely afflicted his early manhood. As a critic, however, he felt bound to condemn as morbid, monotonous and painful the representation of a situation "in which a continuous state of mental distress is prolonged, unrelieved by incident, hope, or resistance; in which there is everything to be endured, nothing to be done"; and accordingly he suppressed the work. Its restoration was justified by its poetic beauty and power, by its importance to an understanding of Arnold's intellectual development and by its illustrational value in the history of *Weltschmerz* in the Victorian Age. For periodical criticism consult T. B. Smart's 'Bibliography of Matthew Arnold' (1892); books on Arnold, by George Saintsbury (1899); H. W. Paul (1902); G. W. E. Russell (1904); W. H. Dawson (1904); J. M. Dixon (1906); S. P. Sherman (1917).

STUART P. SHERMAN.

**EMPEROR**, the title of the highest rank of sovereigns. The word *imperator*, from *imperare*, to command, had very different meanings among the Romans at different periods. It signified one who exercised *imperium* authority, whether in a civil or military capacity. In the time of the republic consuls were called *imperatores* before they entered on their office. The soldiers afterward conferred the title on their general, after a victory, by hailing him *imperator*; the Senate also called a victorious general *imperator* until he had celebrated his triumph. After the overthrow of the republic *imperator* became the title of the rulers or emperors who assumed to themselves personally every department and privilege of civil and military *imperium*. Victorious generals were still, however, sometimes saluted with the title *imperator*, in its original sense. With the fall of Rome the title was lost in the West, but was kept up in the Eastern or Byzantine empire for nearly 10 centuries. In 800 it was renewed in the West when Charlemagne was crowned, by Leo III, as "Carolus Augustus, the God-sent and pious emperor of Rome," which title was borne by his successors until the dissolution of the Holy Roman Empire in 1806.

The Eastern Empire having been finally overthrown by the conquest of Constantinople in 1453, the imperial dignity in the East became extinct. The sultans, who succeeded the emperors, have never received, in official language, the title of emperor. This title was adopted in Russia by Peter I in 1721, but the right of the Russian sovereign to its possession was not acknowledged by the German Empire until 1747, by France in 1745, and by Spain 1759. Napoleon adopted the old idea of an empire, as a general union of states under the protection, or at least political preponderance, of one powerful state. Napoleon crowned himself as emperor in 1804; the title fell into disuse at his deposition in 1815, but was revived by his nephew in 1852, with whom it again ended on 5 Sept. 1870. In 1806 the first German Empire, 1,000 years old, became extinct and the German emperor, Francis II, adopted the title of Francis I, Emperor of Austria. In December 1870 the second German Empire was formed, King William of Prussia having accepted the imperial office and title offered him at Versailles while engaged in the siege of Paris.

Great Britain is considered as an empire, the crown as imperial and the Parliament is styled the Imperial Parliament of Great Britain and Ireland; but the sovereign has not the imperial title in reference to the home dominions, though the king bears the title of emperor of India. The sovereigns of Japan and Morocco are often, though with little propriety, called emperors.

**EMPEROR**, or **PURPLE EMPEROR**, name of a butterfly of the genus *Apatura*. The antennæ are rather long, the ground color of the wings is rusty black, decorated in the male with a purple lustre wanting in the female; seven white spots in the male; as many faint yellow ones in the female; on the four wings above a transverse white band; an ocellated spot and a darker marginal bar on the hinder ones.

**EMPHYSEMA**, ěm-fi-sĕ-mă, a disease of the lungs, in which there is a dilatation of the air vesicles with lack of elastic recoil. It is most frequently the result of persistent high intra-alveolar tension, acting upon weak lung

tissue. The most important symptoms are bronchitis, loss of breath with harsh and wheezy respirations, and a certain amount of cyanosis or blueness of the face, due to insufficient oxidation in the lungs.

**EMPHYTEUSIS**, em-fī-tū'sis (Gr. "implanting"), in Roman law, a perpetual right in a piece of land, for which a yearly sum was paid to the proprietor. It was secured by contract on condition of improvement, as well as payment of rent, and much resembled a feudal holding in the features of perpetuity, etc. See **FEUDAL SYSTEM**.

**EMPIRE STATE**, a name given to New York State because of its predominant wealth and commerce. The expression "Empire," probably rendered more vivid by Berkeley's prophecy made at Newport, R. I., a generation previous. "Westward the course of empire takes its way" was quite common after the Revolutionary War. It was not necessarily of political significance, as relating to a form of government, but referred rather to the course of progress in civilization; or, as we say "expansion." As such, it was applied especially to New York. When the Free Quakers of Philadelphia, led by Colonel Eyre, built their first temple, at Fifth and Arch streets, in Philadelphia, they dedicated it, as the stone inscribed and set in the façade declared, "Erected in the year of our Lord, 1783, of the Empire."

**EMPIRICAL SCHOOL**. See **EMPIRICISM**.

**EMPIRICISM** (Greek, *empeiria*, trial, experience, from the adjective *empeiros*, which means expert, or experienced in). The philosophical view that experience is the source and the criterion of all knowledge; the theory that all knowledge is derived from material or data existing in the form of particular states of consciousness. As sense, outer and inner, is regarded as the source of this material, empiricism, as a theory of the origin of knowledge, is nearly synonymous with Sensationalism (q.v.). Moreover, since historically it has been customary for representatives of empiricism to explain the connections and relations of ideas by means of the principle of association, the theory is closely connected with Associationism. Empiricism, however, is not alone in its appeal to experience; all modern systems profess to draw their conclusions from this source. But as a philosophical theory, it is distinguished by the particular way in which it envisages the mind and its content. For it, the mind is either merely the place or support of ideas (as for Locke), or (with later writers) simply a general name that is given to the stream of conscious processes; it is not itself a contributing factor in experience and has no power to supply ideas or principles which are not already furnished to it by the original data. At birth the mind is like a blank sheet of paper: it contains no innate ideas, and has no original capacity. In this respect empiricism is opposed to Nativism (q.v.), Transcendentalism (q.v.), and all theories which find in experience some expression of the nature of reason or intelligence.

As a theory of the origin of knowledge, empiricism has the task of explaining how the more complex and general aspects of knowledge and of concrete experience have been derived from the simple psychological elements which it assumes as its data. As these elements are par-

ticular and isolated states of consciousness, the most difficult problem for empiricism has been to explain the connectedness of experience, and more especially the nature and validity of general propositions. How can experience, which is by hypothesis originally constituted of particular states, guarantee the truth of universal statements, such for example as are arrived at by science? Since for this theory the mind possesses no general principles in the form of innate truths from which it might deduce conclusions, it is evident that empiricism will emphasize induction as its method of reasoning and seek to explain universal propositions as derived in this way from particular experiences.

In regard to the validity of knowledge, empiricism holds that only those ideas are valid that have their source in and can be traced back to some original data which can be exhibited in the form of actual impressions or contents of consciousness. In Hume's statement, all ideas are derived from some original impression. If then it is impossible in any case to point to the impression from which our supposed idea is derived, we have to conclude that the idea is no proper idea at all, but only a "fiction" of the imagination. It is by means of this principle that Hume and the empiricists who have constantly followed his lead discredit the idea of the self and all universal principles and categories which cannot be traced back to some particular experience or group of experiences.

Empirical views regarding the origin and criterion of knowledge were maintained by the Greek Sophists, and more systematically by both Stoic and Epicurean schools. In the Middle Ages, the doctrine was maintained in the formula, "Nihil est in intellectu quod priusquam non fuerat in sensu." But it has been in the modern period that empiricism has been systematically developed and applied as a philosophical doctrine. The name is especially connected with the English school that begins with John Locke and includes as its chief representatives, George Berkeley, David Hume, David Hartley, Joseph Priestley, James Mill, J. S. Mill and A. Bain. The views of H. Spencer also are very largely determined by the influence of this school, though his application of the doctrine of evolution leads him to some new conclusions. It should be recognized, however, that the influence of empiricism has not been confined to any single group of thinkers, but that it has in a sense formed a general platform for the sciences of mind and society. By providing a set of conceptions through which the inner life can be readily ordered and made comprehensible, empiricism came to be accepted as a matter of course by writers on psychology, ethics, sociology and education, oftentimes without even being aware that their procedure had committed them to any philosophical position. During the past generation the empirical view of mind and experience has furnished the framework which has largely determined the course of investigations in these fields, even when, as in the case of Spencer, they have been accompanied by professions of allegiance to the principle of development. The truth is that the empirical way of representing experience, as constituted out of atomic "states" or "elements" which unite in accordance with certain principles to form "complexes," is so convincing to "common sense" and at the same time so suc-

cessful in rendering the mind picturable and describable in terms of science that it appears to be both natural and indispensable. It has accordingly happened that the demonstrations of the shortcomings of empiricism as a philosophical doctrine which have been furnished notably from the point of view of Kant and the idealistic school (cf. T. H. Green, 'Introduction to Hume') have failed to overthrow the influence and standing of this doctrine in popular favor. The rival view of experience put forward by Kant and his followers, being more difficult to understand and to envisage, did not so readily form the basis for investigation and discussion in this field, and so the dominance of empiricism remained almost unshaken. In recent years, however, there are signs that investigations into psychological and social phenomena are becoming more fully penetrated with historical and developmental conceptions, and are being carried beyond the atomic and mechanical logic of the older empiricism. This movement beyond empiricism is illustrated by the importance attached to studies of behavior and function at the present time, and especially by the tendency shown to interpret mind and its various types of experience in the light of the categories of historical development.

**Radical Empiricism.**—With the movements described in the last sentences there may be connected the position outlined by William James, to which he gave the name of "radical empiricism." James distinguishes his own empiricism from that of Hume and the English school by insisting that in addition to the substantive states of consciousness to which the latter had called attention, there are also certain "conjunctive relations" given directly through experience, and so to be accepted as equally real in a true empirical theory. Radical empiricism thus professes to give a more accurate description of experience than that of the earlier school; it recognizes the fact that experience presents itself as whole and continuous and not as a series of discrete substantive states or atoms. James' object is to maintain the wholeness and continuity of experience, and at the same time to avoid any appeal to rational elements which cannot be themselves experienced as facts. "Radical empiricism," just by being thoroughgoing in its empiricism, believes itself able to describe the thing just as it is experienced, without imposing upon it any conceptual form through logical interpretation.

**Empiricism in Medicine.**—The Empiric school of medicine arose in Alexandria in the 3d century B.C., in opposition to Dogmatism. The latter supported itself by appeal to the theories of Plato and earlier philosophers, while the empirics took Aristotle as their leader. They avoided the one-sided theorizing tendencies of the dogmatists regarding the ultimate causes of disease, and emphasized the practical ends of medicine as an art of therapeutics. Though the influence of this school was in many respects beneficial in leading to the study of cases and to careful methods of observation, it tended in the end to resolve itself into charlatanism, and to occupy itself exclusively with a search for specifics. Consult Locke, J., 'An Essay Concerning Human Understanding' (1690); Mill, J., 'An Analysis of the Phenomena of the Human Mind' (1829); Hodgson, S. H., 'Metaphysics of Experience' (1898); Green, T.

H., 'Introduction to Hume' (1874); James, W., 'Essays in Radical Empiricism' (1912); Moon, R. O., 'The Relation of Medicine to Philosophy' (1909).  
JAMES E. CREIGHTON,  
*Professor of Logic and Metaphysics, Cornell University.*

**EMPIRICISM, in medicine,** refers to at least two different things. In the age of renovation, or the reform period in medicine, a special group of men, Phalinus and Serapis at their head, founded what was called the Empirical School. They were disciples of Herophilus and Erasistratus, and from 200 to 300 A.D. they formed one of the most important Alexandrian schools. Their followers were mostly opposed to the teaching of the Dogmatic School. Their chief point of view was that of practical observation, as opposed to the theoretical speculations of the Dogmatic School. Their chief alliances were with the skeptics. Anatomy, inasmuch as it could teach nothing of physiology, they believed was of secondary importance.

At the present day what is meant by empiricism is the following of accumulated experience independent of rational explanation. A physician uses a drug empirically because he, or others, believe it to be of service, although no reason can be given by him, nor by others, why it should be of service. Little by little, the real causes of the action of drugs that physicians have used from time immemorial has been revealed by students of medicine and the reproach that medicine is an empirical science has little weight at the present time. See **EMPIRICISM, in philosophy.**

**EMPLOYERS' ASSOCIATIONS,** combinations of business establishments for the purpose of dealing with or fighting labor organizations. They are a special form of capitalistic organization, exclusive of those general combinations (see **COMBINATION, INDUSTRIAL**) which have been formed to advance the political, commercial or legal interests of employers. Their history follows the history of trade unions—they have been weak or strong according to the strength of the unions. Two distinct types of employers' associations prevail (1) bargaining associations; (2) hostile associations. The former recognize the unions while the latter are opposed to every form of collective bargaining.

The bargaining associations aim to check the abuses and excesses of organized labor by endeavoring through deliberation and discussion to work out some system of agreement with their employees. The employment of labor is treated as a simple business proposition. The first employers' association of national importance of this type was the United States Potters' Association formed in 1875. The Stove Founders' Association formed in 1886 stimulated similar organizations in all branches of that industry. By 1905 national employers' associations representing the stove and furnace making, metal foundry work, lake transportation, machine construction, publishing and printing, marble cutting and ready-made clothing industries were successful in making working agreements with employees. Employers' associations have been steadily on the increase. Their organization is essentially similar to that of the unions. They have local bodies with

national federations, and nearly all maintain employment agencies, secret service departments (analogous to the walking delegate system); control the members who are forced to agree to measures adopted by the central organization; issue publications; and have a defense fund.

The class of hostile employers' associations is a comparatively recent development and represents the counteraction of the forces of aggressive industrial unionism. In many cases the associations were first formed for the purpose of negotiating joint agreements with the unions, but after the failure of negotiations or the breakdown of an agreement, they assumed their present form. In some cases associations which have been hostile have resumed relations with unions.

But there is a strong tendency for an organization of this type to develop exclusive principles and policies which make an agreement with the unions impossible. Their platform shows absolute disagreement with unionist principles. They insist that the conditions of employment shall be determined by the individual workman and the individual employer. This generally means that employers, either as an association, or, in many cases, as individuals, have the right to dictate the terms of employment and of discharge. Discrimination is made either against all union workers, or else their number is so limited as to prove ineffective in agitation. Any indication of spread of unionist principles is watched for and instantly suppressed. They deny the privileges of boycott, strike, etc., but do not hesitate to seek redress in event of such crises by employing strike breakers and spies. This extreme form of hostility takes on a highly anti-social aspect. But the more enlightened employers of the hostile associations have begun to realize the vast psychological problems underlying unrest and opposition of laborers; and they attempt to change conditions where there is evidence of dissatisfaction. They also endeavor to ameliorate affairs by profit-sharing and welfare systems, safety devices and offering opportunities for advancement. This minimizes the advantages of unionism and secures satisfactory results. A striking example of this type of reform was evinced by the voluntary introduction of the eight-hour law into the Western Union Telegraph Company in 1917. Among noteworthy hostile employers' associations may be mentioned the National Association of Manufacturers (q.v.) and the Citizens' Industrial Association of America.

The weakness of the first type of employers' association lies in the fact that a considerable number of employers, though accepting results of collective bargaining, do not belong to the associations and thus lessen the force of bargaining power. The United States government through its Board of Mediation and Conciliation recognizes the fact that agreements made between employers' associations and trade unions form a basis for settling trade problems which is equitable, elastic and intrinsically democratic. Consult Hollander and Barnett, 'Studies in American Trade Unionism' (Chap. 12, 1912); Mitchell, 'Organized Labor' (Chap. 22, Philadelphia 1903); Gilman, N. P., 'Methods of Industrial Peace' (Chap. 3, 1904). The 'Reports of the United States Industrial Commis-

sion' contain valuable studies in mediation and conciliation which are pertinent to the workings of these associations. Consult especially 'Senate Documents' (Vol. XIX, Washington 1916).

**EMPLOYERS' LIABILITY**, a term generally used to denote the liability of employers for injuries inflicted upon workmen in their employ. In many States workmen injured in the course of their employment can recover damages from their employers only if the employers be proved guilty of negligence and if such negligence resulted in the injury. Employers are not liable for injuries resulting from the obvious occupational risks or for accidents that are inevitable or for which blame cannot be fixed. Since an employer is responsible for injuries due to his own negligence or that of his servants, an employee thus injured supposedly would be entitled to recover damages from the employer. But under the common-law relation of master and servant, as interpreted in foreign countries until recently, and now discarded in nearly all civilized countries save the United States, an employee, on entering service, agrees to run all the ordinary risks of the service, including injuries that might befall him through negligence on the part of fellow-employees. The so-called absolute duties of the employer are to furnish a reasonably safe and proper place in which employees may engage in their work, suitable appliances, reasonably competent employees, such as superintendents, foremen and other servants, and rules and instructions when they are reasonably necessary. The employer is liable for gross negligence, for risks of an extraordinary nature involved in the service, and for all acts of negligence, whether committed by himself or by employees, occurring outside the regular service. Modern industrial conditions necessitated a modification of these common-law rules, especially in England, where the liabilities of employers has been greatly extended by such acts as the Employers' Liability Act of 1880 (43 and 44 Vict. c. 42) and the Workmen's Compensation Acts of 1897, 1900 and 1906 (60 and 61 Vict. c. 37; 63 and 64 Vict. c. 22; and 6 Edw. VII c. 58). Under this legislation employees are virtually insured by the employer against injury while in his employ, the employer being compelled to pay a limited sum to the injured or to the families of employees killed by such accidents, whether or not due to the negligence of the employer or to that of fellow-employees.

In the United States the employee must prove that in a given instance the master has failed to fulfil one of the above-mentioned absolute duties. In contesting such an action the employer, in general, may rely on three defenses: (1) that the injury sustained by the employee was among the ordinary occupational risks which he assumed when entering the employ of the master, or was caused by a danger of which the employee either was or should have been cognizant, but in spite of which he continued to work; (2) that the injury inflicted upon the employee was not due to negligence on the employer's part but on the part of a fellow-servant of the plaintiff, wherefore the employer is not liable since the employee assumed this risk, too; (3) that the injured employee failed to use reasonable precautions

against accident and that this contributory negligence had resulted in his injury. During the past few years several of the United States have enacted laws of a very diverse character which differ widely from the general principles of the American system as above set forth and considerably extend the liability of employers. Attempts have been made to offset the liability laws by compelling employees to sign contracts waiving the benefits of such legislation, but subsequent enactments have overcome this evasion of the law by forbidding such contracts or rendering them null and void. The liability laws should be studied in connection with the new compensation laws which have been enacted to replace the former in order to provide a system of definite compensation for accident without litigation. Some of these laws have been attacked as unconstitutional on the ground that the forcible grant of compensation to an employee injured through no fault of the employer was confiscation of property for no public purpose and without due process of law. Where the courts have sustained such contentions the tendency has been to amend the constitutions so as to permit such legislation, and acts passed under such amendments have been upheld in the court of last resort. The rapid advancement of the movement to compel compensation to injured workmen led to the extension of the field of insurance, some companies now issuing employers' liability policies, under which, for a stipulated premium, the employer is insured against loss resulting from accidents to employees, any damages for which the employer may be legally liable being paid by the insurance company. The most recent laws make such insurance compulsory, while State insurance funds, placed on a sound actuarial basis, have been created in some States, since, as the New Jersey commission on employers' liability reported in 1915, previous laws have not ensured the payment of compensation in case the employer should become insolvent. Most of the States have compensation laws which apply to public as well as to private employees, while the Canal Zone order and the Federal statute apply to public employees and to persons engaged in interstate commerce. In general either compensation or insurance is provided and either type of law may be elective or compulsory. Alaska, Colorado, Connecticut, Illinois, Indiana, Iowa, Kansas, Louisiana, Maine, Michigan, Minnesota, Montana, Nebraska, New Hampshire, New Jersey, Pennsylvania, Rhode Island, Vermont and Wisconsin provide elective compensation; while in Arizona, California, Canal Zone, Hawaii, Maryland, New York and Oklahoma the compensation is compulsory as it is under the Federal statute. Massachusetts, Nevada, Oregon, Texas and West Virginia have elective insurance laws, while Ohio, Washington and Wyoming have compulsory insurance laws. See ACCIDENTS; WORKMEN'S COMPENSATION; LABOR; FAMILY LAW; FACTORIES AND FACTORY INSPECTION; DISEASES, OCCUPATIONAL.

**Bibliography.**—Consult the files of the *American Labor Legislation Review*; Barnett, H. N., 'Accidental Injuries to Workmen' (London 1909); Beyer, D. S., 'Industrial Accident Prevention' (Boston 1916); Boyd, J. H., 'Workmen's Compensation and Industrial Insurance' (Indianapolis 1913); Cowee, G. A.,

'Practical Safety Methods and Devices' (New York 1916); Connor, J. F., 'Employers' Liability, Workmen's Compensation and Liability Insurance' (New York 1916); Clark, L. D., 'Law of the Employment of Labor' (New York 1911); Dawson, M. M., 'Constitutionality of Workmen's Compensation and Compulsory Insurance Laws' (in *Case and Comment*, Vol. XXII, pp. 275-280, New York 1915); Doherty, P. J., 'Liability of Railroads to Interstate Employees' (Boston 1911); Eastman, C., 'Work-Accidents and the Law' (New York 1910); Forsyth, C. H., 'Workmen's Compensation in the United States' (in *American Underwriter*, Vol. XLV, pp. 89-99, 136-145, 239-250, New York 1916); Glass, W. M., 'The Law of Workmen's Compensation' (Rochester, N. Y., 1916); Henderson, C. R., 'Industrial Insurance in the United States' (Chicago 1911), and 'Workmen's Insurance' (Philadelphia 1912); Hotchkiss, W. H., 'The Case against State Insurance' (New York 1913); 'Legal Liability of Employers for Injuries to their Employees in the United States' (U. S. Labor Bureau 'Bulletin' No. 74, Washington 1908); Otis, S. L., 'Manual of Compensation and Liability Insurance' (New York 1914); Paterson, J. V., 'Workmen's Compulsory Compensation System' (Seattle 1912); 'Risks in Industry' (in 'Annals of the American Academy of Political and Social Science,' Vol. XXXVIII, Philadelphia 1911); Sherman, P. T., 'The Consequence of Accidents under Workmen's Compensation Laws' (in *University of Pennsylvania Law Review*, Vol. LXIV, pp. 417-448, Philadelphia 1916); Seager, H. R., 'Social Insurance' (New York 1910); Thornton, W. W., 'Treatise on the Federal Employers' Liability and Safety Appliance Acts' (Cincinnati 1916); 'Workmen's Compensation Laws of the United States and Foreign Countries' (U. S. Labor Statistics Bureau 'Bulletin' No. 126, Washington 1914); Walgren, J. A., 'Federal Employers' Liability Act' (Chicago 1916).

**EMPLOYMENT BUREAUS**, establishments, whether private or public, at which those seeking employment are put into communication with those who are offering it. Private employment bureaus are found in every large city, but they are often conducted without judgment, sometimes have been accused of dishonesty, in many cases are mercenary, and their usefulness is at least problematical. In order to correct the evils arising from the practice of these bureaus, much remedial legislation has been passed. No agency is now allowed to charge a fee before informing an applicant of a situation that is actually open to him, and should such position, through no fault of the applicant, be found not open to him as understood when the fee was paid, such fee is required to be returned promptly. All employment bureaus are under the supervision of some State bureau, while some cities impose license fees and bonds of varying amounts and limit the amounts of the fees to be charged for registration, also requiring the return of fees should applicants fail to secure positions within a prescribed time. Public bureaus, opened by the national or city government, are non-mercenary and the motive that has prompted their establishment is a sound humanitarian and political motive. Such bureaus have two practical objects. They are a means of communication between employer

and employee—labor exchanges, as they are called in France. In the second place they do something toward settling the wage question, by giving quotations of the amount offered and asked. Ohio was the pioneer in the movement for free public employment offices in the United States, instituting hers in 1890, and the movement has spread so that 19 States now have more or less effective systems of public employment offices in about 60 different cities, the offices usually being under the supervision of a superintendent of free employment offices, or some other State official, such as the commissioner of labor or the chief of the bureau of statistics. These offices find employment annually for about 300,000 wage-earners at exceedingly low cost, ranging from four cents for unskilled workers in Seattle to \$2 or more in some small offices. With two exceptions the various laws stipulate that there shall be no charge to employer or employee for the service rendered. Municipal bureaus are operated independently in seven States. In 1914 the United States Department of Labor, through a bureau called the Federal Employment Bureau, began the establishment of 38 branch offices in various parts of the country and subsequently broadened the scope of the work so as to include a woman's division. The country is divided into 18 zones of distribution, each with headquarters in a large city; besides the station headquarters there are 80 sub-branches.

The public governmental employment bureau originated in France. In 1848 one such bureau was established in each of the mairies of Paris. The institution languished and in 1851 a measure submitted to the legislative assembly for the establishment of a comprehensive system of employment bureaus throughout the country failed to be adopted and nothing of importance was accomplished until 1888 when the Bourse de Travail was opened at Paris, which institution received a subsidy of 150,000 francs from the government. In 1892 a large building was erected and became the headquarters of labor syndicates, but a year later this was closed because of a dispute between the government and the labor syndicates. In 1896 it was reopened under the management of a commission appointed jointly by the government and the labor syndicates. There are also numerous bureaus in France operated and managed by unions of labor syndicates whose chief endeavor is to place members of syndicates but who may aid other workmen in the hope that they will join the syndicate. In order to equalize the supply of labor in the various sections of the country, a national bureau was established, but though this received government aid in 1900, such aid has since been withdrawn because the bureau endeavored to restrain workers from entering districts wherein strikes were in progress. About 50 cities have labor bureaus of some sort. Belgium established such a system in 1870; Switzerland followed suit with a labor bureau at Bern in 1888 and with another at Basel in 1889; and since that time Italy has developed a system, the most important exchange being at Milan.

The first employment bureau in England was opened at Egham, near London, in 1885, but when the Local Government Act of 1894 went into effect this was discontinued. From 1885 to 1906 a voluntary bureau was in operation at

Ipswich but in the latter year the Distress Committee took over its work and within a short time numerous municipal and private bureaus were taken over by the Distress Committees under the local governments. In 1909 an act became law making the establishment of employment bureaus or labor exchanges compulsory throughout the United Kingdom, and there are now more than 425 such exchanges with about 1,100 local agencies, all under the control of a central office at London and eight divisional offices in various cities. This federated system of labor exchanges is chiefly for unskilled labor but it works in conjunction with the trade union bureaus for skilled labor and has been very successful.

Germany's first municipal bureau grew out of a private bureau established at Freiburg in 1892, and the movement has been taken up enthusiastically by almost every city of importance. Ordinary commercial bureaus in Germany concern themselves chiefly with securing positions for domestic servants. The trade unions have their own bureaus. The Berlin public employment bureau is under the charge of various united societies but it is granted a subsidy by the city government and is also strictly supervised. A nominal fee is charged to workmen who register but it is free to all employees. The management is equally divided between employers and employees and prominent citizens are in charge of the important committees. The best system is that of Munich. The Bavarian communes are held legally responsible for the conduct of the employment bureaus; the separate municipal bureaus are federated into a complete system with central bureaus in the largest Bavarian cities. No charge is made for services, the municipality defraying the entire cost with the aid of appropriations by the Bavarian government. In almost every German city of 50,000 or more inhabitants a municipal bureau will be found, and such bureaus are particularly successful in southern Germany, but in the northern part of the country the work of the municipal bureau is performed, to a great extent, by voluntary associations, aided by the municipalities. See LABOR LEGISLATION IN THE UNITED STATES.

**Bibliography.**—Barnes, C. B., 'Public Bureaus of Employment' (in 'Annals of the American Academy of Political and Social Science,' Vol. LIX, pp. 185-193, Philadelphia 1915); Beveridge, W. H., 'Unemployment' (London 1912); Devine, E. T., 'Reports on the Desirability of an Employment Bureau in the City of New York' (New York 1909); Greenwood, Arthur, 'Juvenile Labour Exchanges' (London 1911); Hodges, H. G., 'Statutory Provisions for the Achievements of Public Employment Bureaus' (in 'Annals of the American Academy of Political and Social Science,' Vol. LIX, pp. 165-184, Philadelphia 1915); Kellor, F. A., 'Out of Work' (New York 1904); Leiserson, W. M., 'The Movement for Public Labor Exchanges' (in *Journal of Political Economy*, Vol. XXIII, pp. 707-716, Chicago 1915); Nash, M., 'Municipal Employment Bureaus in the United States' (in *National Municipal Review*, Vol. IV, pp. 429-436, Concord, N. H., 1915); Persons, Parsons, Moses, et al., 'Labor Laws and Their Enforcement' (New York 1911); Willoughby, W. F., 'Employment Bureaus in the United States' (Boston 1900).

**EMPLOYMENT MANAGER.** The new profession of employment manager has within the past few years come to be recognized as one of the most vital factors in industry. Ten years ago, workmen were hired by foremen or clerks simply because they happened to apply for jobs that were vacant but without regard for any particular fitness for the work to be performed. Naturally, there was general dissatisfaction, both on the part of employer and employee, and as this greatly increased the labor cost and tended to reduce production, a closer study of the question of the human element in the industrial organization was made, with the result that many manufacturing concerns have placed their employment work in the hands of a trained executive, with the power to hire, place and handle the working force with a view to more efficient labor management.

The employment manager occupies the position of the representative of his company in the labor market. He must be familiar with all sources of labor supply and be capable of selecting the men and women needed for the different positions in his plant in accordance with their fitness for the jobs, for the duties of the employment manager are not only to keep the machines running but to see that they are operated by workers who are able to maintain a high standard of efficiency in the quality and quantity of the goods produced.

As the connecting link between the management and the worker, the employment manager is entrusted with all matters of personnel connected with the company. The hiring of the help, their assignment to tasks that they are fitted to perform, their change of jobs or transfer from one department to another, and, when necessary, their discharge, are matters that rest in his hands. He is the "friend at court" to whom all requests for assistance are made and it is he who must sit as a judge upon all grievances that are brought to his attention, separating the imaginary from the real.

The employment manager must not only enforce the policies of his company and see that all rules for the management of the help are understood and obeyed, but he must also see that there is effective co-operation between his office and the heads of other departments, for his duties require that he keep as fully in accord with the various foremen as with the workers. The successful maintenance of these varied relations requires both intelligence and executive ability of a high type.

This plan of delegating all personnel problems to a skilled employment manager has proved so successful, both in improving production and in promoting an *esprit de corps*, that it has been adopted in nearly all important industrial concerns and in many financial and mercantile establishments.

**Employment Managers' Associations.**—The development of the profession of employment manager has resulted in the organization of associations, or clubs, where the employment managers could meet to discuss the problems arising in their work, exchange experiences and otherwise fit themselves to handle more efficiently the human element so vital to the success of an industrial enterprise. The first employment management society was organized in Boston, about five years ago, and soon proved so helpful to its members that similar employ-

ment executives' organizations have since been formed in nearly all of the industrial centres of the country. Three conventions have been held, Minneapolis, Minn., 1916; Philadelphia, Pa., in 1917, and Rochester, N. Y., in 1918. At the latter, on 11 May 1918, the several organizations formed a permanent association to be known as the National Association of Employment Managers.

**Employment Manager's Course.**—The success of the employment manager in promoting production and stabilizing industrial employment came to be so generally recognized that, in 1918, as one of its war measures, the United States government established an intensive course in employment management, under the direction of the employment management division of the War Industries Board. The first course was inaugurated at the University of Rochester, where the first class graduated on 9 May 1918, and courses have since been established at Harvard, in connection with the Massachusetts Institute of Technology; Boston University, Boston; Columbia University, New York; Carnegie Institute of Technology and the University of Pittsburgh, Pittsburgh; the Case School, Cleveland; the University of Washington, Seattle, and the University of California, at Berkeley. The courses of instruction occupy from six weeks to two months, and the classes, which are conducted by the foremost employment executives and industrial authorities in the country, devote themselves to such subjects of study as the following:

Functions and organization of an employment department; labor turnover, its causes and how to reduce it; character analysis; science of hiring; transfer and promotion; discharge; following employees' progress in the plant; educational work for employees; recreational work for employees; safety and sanitary engineering; method of wage payment; bonuses and profit sharing; hours of labor and fatigue; industrial organization; sources of labor supply; public employment offices and methods of co-operating with them; labor statistics; causes of labor unrest; employers' liability and compensation; history of the labor movement, etc.

In outlining this course of study, the War Industries Board stated that the introduction of the employment manager into industry and the standardization of the services of an employment department is one of the greatest movements taking place in the manufacturing industry in this country, and employers of labor, particularly those having war contracts, were urged to suggest men or women from their organizations as candidates for the government courses.

JOHN R. MEADER.

**EMPLOYMENT MANAGEMENT.** Employment management embraces the work of recruiting, placing, retaining and discharging the working force. This modern method of handling personnel problems was inaugurated by one or two employers of labor a comparatively few years ago, but the plan quickly demonstrated its value so clearly that it has now come to be quite generally adopted, not only in important industrial plants but by many large mercantile establishments and financial institutions as well.

The development of the present system of employment management began when large em-



ployers commenced to realize the fact that the greatest labor problem confronting industry was that of the proper handling of the working organization. The studies of the efficiency engineer proved conclusively that a plant, to operate effectively, must have something more than the number of hands required to run the machinery. If the highest possibilities of production were to be reached it was necessary to obtain and retain the goodwill and active co-operation of the operatives.

This was a problem that had steadily been assuming more serious proportions for many years. In the old days of industry, when master and man worked side by side at the bench the spirit of co-ordination in the average shop was similar to that in the family, but with the growth of industry came the development of the impersonal corporation and the loss of the human touch that had been so largely the source of the loyalty and friendship existing between the "boss" and the worker. The great industries, therefore, found themselves face to face with the necessity of finding a substitute for the human relations which they had sacrificed and employment management, under a trained director of personnel, is their solution of this problem.

The primary purpose of employment management is to stabilize the working organization by reducing the number of men employed to maintain the necessary average working force, or, in other words, by reducing the "labor turnover." To accomplish this end, employment management includes many and varied functions, ranging from the preliminary work of securing the help to the larger social problems involved in guiding and protecting them.

The functions of the department devoted to employment management begin with the selection of the right type of person for the "jobs" to be performed and this naturally includes an analysis and classification of the various tasks, as it is necessary that all prospective employees shall conform as closely as possible to the specifications of the "job-analysis." Once employed, the new operative, if he is a "learner," must be placed under competent instruction, preferably in a segregated school under a specially trained teacher. Close watch must be kept upon his progress, not only during this period of instruction, but during the length of his stay with the concern, in order that he may find no occasion for discontent or discouragement in the fact that he does not profit in proportion to the degree of efficiency which he attains. The performance of these functions, as well as those of a so-called "welfare" character (which are almost as closely allied to the work of employment management), require close personal contact with the workers, the ability to inspire confidence in the genuineness of the firm's intentions to deal justly with its individual employees and the careful maintenance of a system of records through which thorough supervision may be kept over the development of the plant personnel.

Broadly stated, these are the functions of an employment department. Described in detail, the scope of employment management embraces:

**1. Maintaining a Constant Survey of the Labor Market and a List of Available Applicants for Positions.**—Both are necessary

if the organization is to be maintained at its normal standard. It is assumed that an employment department will receive advance notice from foremen of places to be filled and the men to take these "jobs" must come from one of two sources of supply: the outside labor-market or prospect files built up from information obtained from voluntary applicants or from inside the organization, through personal recommendations by operatives already employed. To accomplish this purpose, however, the data must be easily available, which means that the information must be secured and properly filed in anticipation of every possible demand.

**2. Hiring the Right Type of Employees.**—To meet this demand, the employment department must not only be familiar with the character of every operation to be performed but must employ new operatives in conformity with technically correct "job specifications" for all classes of help required. To assure the best results in hiring, all applicants should be carefully interviewed as to domestic relations and individual responsibilities as well as to records of previous employment. While employment managers differ in their opinions regarding the value of references, the data supplied by a statement of previous employment usually affords an illuminative record of the man's accomplishments and most authorities are agreed that knowledge regarding an applicant's personal responsibilities is important in preventing the possible hiring of men for "jobs" paying a smaller wage than that on which they are accustomed to live, as men employed at less than they have previously earned are likely to regard the place as a make-shift rather than a permanent position. The opinions of employment men also differ regarding the value of character analysis based upon personal appearance or psychological tests, although there is a general agreement that tests are advantageous in the case of operatives who are to perform tasks requiring certain well-established qualifications.

**3. Examination of Applicants.**—Many important concerns now require a physical examination of applicants before actual employment, not only as a safeguard against conditions for which the firm might be held responsible under the compensation laws (such as hernia, etc.), but also as a protection for other employees against possible infection.

**4. Introduction of New Employees.**—The introduction of the newly employed worker also devolves upon the employment department. If the employee is a "learner," he is introduced both to the instructor and to other members of the "school"; if a skilled, or semi-skilled, operative, to the foreman and the operatives working near him. An "introduction" must also include an explanation of the policies and regulations of the concern, a description of its welfare activities and full information regarding the location of such important points as the emergency hospital, lunchroom, lockers, washrooms and toilets, stockroom, etc. Lasting impressions of a plant are frequently gained during the first days of employment and an introduction which shows a personal interest in the welfare of a new employee is of incalculable value.

**5. Following up Employees' Performances.**—The work of following up the performances of new employees is one of the most important functions of employment management. In the schools, it assumes the responsibility of determining when the "learner" has attained a sufficient degree of efficiency to graduate as a skilled operative; with all operatives, the "follow-up" covers such tangible evidences of efficiency as: (a) General conduct; (b) Earning capacity from week to week; (c) Absences and tardiness; (d) General health and accidents; (e) Regular ratings as to efficiency in: (1) Workmanship, covering both quantity and quality of product as well as record of waste; (2) Reliability and industry; (3) Attitude toward work.

A record of this character is of great value to the employment director in many ways. It enables him to see that "learners" are transferred to regular "jobs" as soon as they are capable of assuming greater responsibilities; it supplies the information from which a careful study of the average earnings of the employees can be made, both as a check upon possible decreases in productive ability of the individual worker and as an indication of rate-changes, transfers or promotions that may have become desirable. From this record may be secured the facts regarding tendencies toward absences and tardiness that require further investigation.

**6. Investigations.**—Much of the success in employment management depends upon the thoroughness of the department's investigations. All instances of chronic tardiness should be investigated and, if possible, a means should be found to remedy this defect. Absences must also be investigated and in each case a record should be made of the causes. In cases where the absence is due to illness, injury or personal troubles, advice can often be given and material assistance afforded, and where the failure to report is the effect of a misunderstanding that has inspired the desire to "quit," a personal interview at this early stage in the withdrawal is frequently the means of adjusting the differences and saving a valuable employee.

**7. Arrangement of Transfers.**—Transfers in an industrial plant usually are made for one of two reasons: (1) Because an operative has been found capable of assuming greater responsibilities, and (2) because an operative has failed to "make good" in one "job" but is to be given a chance to perform a different task for which he seems to be better fitted. The practice of filling the higher positions by promotion has proved so valuable in developing an *esprit de corps* that this rule should never be violated except in cases where there is no material available within the plant, while the plan of transferring the more inefficient operatives instead of discharging them has been proved to be a valuable change in practice by many important concerns. It is one of the vital functions of employment management to see that promotions are given to those deserving them and that the "misfit," who may be nothing worse than a round peg in a square hole, is put where he may perform effective service.

**8. Power of Discharge.**—In plants where the hiring and placing of workers is delegated to an employment department, the final discharge of an operative becomes one of the functions of employment management. In concerns

where this rule is in force the authority to discharge unconditionally does not rest with the foreman. A foreman usually is given the privilege of saying when a man shall not continue to work in his department but the authority to decide that an operative shall not be permitted to work in any other part of the plant is delegated to the employment manager, subject, of course, to the approval of the plant manager.

To perform these duties successfully and without weakening departmental discipline requires that all cases shall be handled diplomatically and each case upon its own merits. In fact, where these methods are pursued, the employment manager becomes a man who sits in judgment upon all questions of differences between the employees and their superiors, who is entrusted with the important duty of seeing that the foreman is protected in the exercise of all just methods of directing his help and that every employee is assured a square deal.

**9. Maintaining the Reputation of the Firm.**

—If a desirable class of employees is to be obtained and retained it is necessary that the concern should have a "good name" among the workers. While the wages paid, the hours of labor and other conditions that depend upon the policy of the management, have a great deal to do with the development of the reputation of the firm, fully as much depends upon the character of the employment management, as it is essential that both applicants for "jobs" and those actually working in the plant shall be pleasantly impressed by the treatment they receive at the hands of the employment department. This means (1) All applicants must be handled promptly and treated courteously, applications being taken and filed for future reference where there are no positions to be filled; (2) Employees shall invariably be treated courteously and justly and shall be advised and assisted in every way practicable; (3) Even those who are discharged, or who are leaving the concern because of dissatisfaction, shall be treated so fairly and courteously that they will go away with as agreeable an impression of the firm as possible.

**10. Management of Welfare Activities.**—The various welfare activities of the firm, including those of a social and educational character, also come under the direction of the employment department. See INDUSTRIAL WELFARE.

**11. Keeping Labor Records.**—In order that these various functions may be performed effectively, it is necessary that a system of department records shall be adopted and carefully kept. These include records of (1) Applications for employment and data regarding condition of labor-market. (2) Employment cards, containing such information as: Name and address, date of application, place and date of birth, date of arrival of foreign-born immigrant, degree of education, language spoken, domestic condition and record of previous employment. (3) Physical examination. (4) Daily report of those tardy and absent, with causes. (5) Industrial progress of the individual worker, with special attention to progress of "learners." (6) Labor turnover sheet, detailing the number "quitting" or discharged both by departments and "jobs," with such facts as (a) reasons for withdrawal, (b) length of service, etc. See LABOR TURNOVER.

In plants where these methods have been

adopted there has been a marked improvement in the personnel, a reduction of the labor turnover and general stabilizing effects that have been clearly reflected both in the quality and the quantity of product.

JOHN R. MEADER.

**EMPORIA**, Kan., city and county-seat of Lyon County; on the Neosho River near its junction with the Cottonwood, in the central part of the State, and on the Missouri, Kansas and Texas, and a division point of the Atchison, Topeka and Santa Fe and other railroads; 60 miles southwest of Topeka. It is the commercial centre for a large section of country devoted to farming and dairying and to the fattening of western range cattle for the eastern market. Emporia has a thriving jobbing and export trade and some manufactures, including marble and iron works, carriage and canning factories, woolen mills, corrugated metal works, and flour and grist mills. It has three banks, with a combined capital of over \$250,000 and doing a large annual business and daily and weekly newspapers. Gas is served by a private company, and the waterworks and electric-lighting plant are owned and operated by the city. Emporia is the seat of the State Normal School (2,000 students), and of the College of Emporia (Presbyterian), and the Western Conservatory of Music, and has a business college, railroad and public libraries, nine school buildings, 11 churches, and many handsome business buildings and private residences. It is the largest town in Kansas that never has permitted a saloon to open within its limits since the passage of the prohibitory law in 1880. The city adopted the commission form of government in 1910. Emporia was founded in 1856 by P. B. Plumb, afterward United States Senator, and a group of pioneers from the Middle States; it was incorporated in 1870. Pop. 9,328.

**EMPYEMA**, ěm-pĩ-ě'mā, a collection of pus consequent on pleurisy. True empyema is pus secreted from the pleura; the false, when an abscess of the lung bursts into the cavity of the chest. When the quantity of fluid is so large as to cause great dyspnoea and endanger life, it must be let out by tapping the chest.

**EMPYREAN**, a word used by the ancient Greek philosophers to designate the highest region of the heavens, where the purest and most rarefied elements of fire and light exist; and by mediæval poets to indicate the ninth heaven, the home of the blessed. In modern poetry the empyrean is merely the over-arching dome of the heavens.

**EMPYREUMA**, ěm-pĩ-roo'mā (Gr. "a live coal preserved in ashes"), the smell acquired by organic matter when subjected to the action of fire, but not enough to carbonize it entirely. The products of imperfect combustion, as from wood heated in heaps or distilled in close vessels, are frequently distinguished as empyreumatic.

**EMS**, ěmz, Germany, a celebrated watering place in the Prussian province of Hesse-Nassau; on the river Lahn. The environs are beautiful. As early as 1583 it was a town of resort as a watering-place. The mineral waters at Ems are warm — from 70° to 133° F.; they are of the saline class, containing large quantities of carbonic acid gas, and are used with

much effect in chronic catarrhs, pulmonary complaints and some other diseases. The history of the town dates back to the 9th century, and the lead and silver mines have been worked a number of years. Since 1865 the fame of the springs has overshadowed its industrial and trade advantages. It was here that the memorable interview between the king of Prussia and the French ambassador, Benedetti, took place which formed the prologue to the Franco-Prussian war of 1870-71. Pop. 6,519.

**EMS**, river of Germany, which rises at the southeast extremity of the Teutoburger-Wald, in Lippe-Detmold, flows northwest through Rhenish-Prussia and Hanover, and into the Dollart, near Emden; length about 210 miles. It drains an area of about 4,600 square miles. Its chief affluents are the Aa, the Haase, the Hessel, and the Leda, all from the east. It is navigable as far as Papenburg for light vessels, but it supplies water to numerous canals, which are used for both irrigation and navigation. In 1818 it was connected by a canal with the Lippe, and thus with the Rhine, and its importance has been greatly increased by the opening of the Dortmund-Ems and other canals.

**EMS DISPATCH**. The historical designation of the communication which precipitated the Franco-German War of 1870-71. The history of the famous Ems telegram, with the texts of the original dispatch, is as follows:

Isabella, Queen of Spain, deposed in 1868, formally abdicated 25 June 1870, and the Spanish throne was thus left vacant. On 5 July the foreign governments were notified, and the fact was generally made known that Prince Leopold of Hohenzollern, evidently with the approval of the King of Prussia, had consented to become a candidate for the vacant throne. The announcement created intense excitement in France. Seven days later the withdrawal of Prince Leopold's candidacy was made public.

The next day, 13 July, the French ambassador, Count Benedetti, forced himself upon the presence of the King of Prussia at Ems and insisted that the king make a formal and specific declaration that no Hohenzollern Prince would be permitted to accept the throne of Spain. The king declined to listen to such demands and broke off the interview. When the account of what happened was sent to Bismarck, it was with permission to "use" it. Bismarck used it by giving to the press abridged features of the French demand, with the result that the Germans were inflamed against France, France declared the nation insulted, and war was declared. The details are shown in the texts, which follow:

This is Abeken's telegram of 13 July 1870 to Bismarck:

"His Majesty the King writes to me: 'Count Benedetti caught me on the Promenade and importunately requested me to authorize him to send a telegram at once saying I bound myself not to consent to the Hohenzollern candidature should they recur to it at any future time; this I declined, and rather sternly at last. One cannot enter *à tout jamais* into such an engagement. I, of course, told him that I had no news, but as he got his from Paris and Madrid sooner than I did, he must understand that my government was taking no part in the matter.'

"Since then his Majesty has received a letter from Prince Karl Anton. His Majesty had informed Count Benedetti that he was expecting news from the Prince, but, having regard to the above reasonable demand, his Majesty resolved, on the advice of Count Eulenburg and myself, not to receive Count Benedetti again, but merely to send him a message by an adjutant to the effect that his Majesty had now received from the Prince the confirmation of the news which Benedetti had already received from Paris, and that his Majesty had nothing further to say to the ambassador. His Majesty leaves it to the decision of your excellency whether this new demand of Benedetti and our refusal to comply therewith should not be forthwith communicated to our ambassadors and to the press."

As issued by Bismarck, the telegram read as follows:

"After the news of the renunciation of the Prince of Hohenzollern had been officially communicated by the Spanish government to the French government, the French ambassador in Ems nevertheless demanded that his Majesty should authorize him to telegraph to Paris that his Majesty pledged himself for all future time never again to give his consent to the Hohenzollerns resuming their candidature. His Majesty has thereupon declined to receive the ambassador again and has informed him through the adjutant that he has nothing further to communicate to the ambassador."

Consult Barrett-Lennard (Mrs.) and Hoper (M. M.), Bismarck's Pen: 'The Life of Heinrich Abeken' (London 1911).

**EMSER**, *ēm'zēr*, Hieronymus, German Roman Catholic theologian: b. Ulm, 26 March 1472; d. Dresden, 8 Nov. 1527. In 1502 he became professor at the University of Erfurt, where Luther is said by him to have been among his pupils. In 1504 he established himself at Leipzig, where he also lectured at the university. He served as secretary to Duke George of Saxony, who sent him on a mission to Rome, in order to obtain the canonization of Bishop Benno of Meissen. With Luther and the theologians of Wittenberg generally he was on good terms until the disputation of Leipzig in 1519, from which time he made, in union with Dr. Eck, incessant endeavors to oppose the increasing influence of Luther and the progress of Protestantism. The German translation of the Bible by Luther was attacked by him as erroneous, whereupon it was forbidden in Saxony by Duke George. Emser then himself published a translation of the New Testament into German, made from the Vulgate (1527). He also wrote 'Vita S. Bennonis,' as he ascribed to Saint Benno his recovery from a severe sickness.

**EMU**, the only representative of the family *Dromaiidae*, and with the cassowaries the Australian representatives of the order *Struthionidae*. In size the emu ranks between the African ostrich and the rhea of South America, the African bird being seven feet in height and the emu five. In general appearance and form it is more bird-like than either of the others. Like the cassowary of northern Australia, its head and neck are feathered, and the back is gracefully arched. Its body is covered with a rich brownish plumage. With the rhea and cassowary, it has three toes on the foot, while the African ostrich has but two. The emu is a bird

of the plains, where it feeds upon fruits, herbs, and roots. The nest is scooped in the sand, and the number of eggs is six or seven, of an attractive green, each measuring five inches in length. The feathers have no ornamental value, and the flesh is eaten only by the natives. Coursing the emu has been carried to such an extent that the birds of New Holland, once spread throughout the whole continent, are now in many parts exterminated. It is valued by the natives chiefly for the fat beneath the skin which contains great quantities of oil. The emu utters a faint booming noise and sometimes a shrill piping note. In confinement it is found to be tractable, and is readily tamed.

**EMUCKFAW AND ENOTACHOPCO**, Battles of, in the War of 1812. After the battle of Talladega (q.v.), the volunteers mutinied and on 10 Dec. 1813 demanded their discharge, but on 14 Jan. 1814 Jackson was reinforced by 900 sixty-day militia and therefore decided to co-operate with Gen. John Floyd (who had recently won the battle of Autessee, aiming at Emuckfaw, a town 40 miles north of Tuckaubatchee (q.v.)). On 20 January with 930 militia and about 200 Creeks and Cherokees, he camped on Enotachopco Creek, 12 miles from Emuckfaw, where on the morning of the 22d he was attacked by the Indians but repulsed them with great slaughter and drove them nearly two miles from the field. On the 23d Jackson began the return journey to Fort Strother but the next day, while crossing Enotachopco Creek, the Indians attacked and threw his force into disorder, many of the troops fleeing. But Colonel Carroll with 25 men maintained their ground and, rallying the fugitives, Jackson soon turned defeat into victory. His loss in the two fights was 24 killed and 71 wounded, and that of the Indians 200 dead and many wounded. On 27 January he returned to Fort Strother where he remained until the battle of Horseshoe Bend (q.v.), Floyd in the meanwhile having fought the battle of Tuckaubatchee (q.v.). Consult Adams, Henry, 'United States' (Vol. VII, pp. 247-249); Fay, H. A., 'Official Accounts' (pp. 170-178); Lossing, 'War of 1812' (pp. 773-777); Wiley and Rines, 'The United States' (Vol. V, pp. 452-453); biographies of Jackson by Parton (Vol. I, pp. 487-494), Buell (Vol. I, pp. 318-321), Frost (pp. 205-223).

**EMULSIN** ( $\beta$ -glucase), a mixture of closely related enzymes which hydrolyze the  $\beta$ -glucosides. It contains a  $\beta$ -glucase proper, a cyanase, an amygdalase and a lactase. It is found in many seeds and especially in the bitter almond, but also in the sweet almond and the kernel of the cherry pit. The addition of a small amount of water to this seed develops the characteristic reaction and the formation of the oil of bitter almonds, containing the deadly poison prussic acid in solution. Emulsin is exceptionally wide in its action, owing probably to its compound nature. But it is commonly considered as a unit, and a specific enzyme for  $\beta$ -alkyl glucosides; and all glucosides which are hydrolyzed by it are regarded as derivatives of  $\beta$ -glucose. Some of its properties are erratic: it hydrolyzes isomaltose, but synthesizes glucose to maltose. Emulsin hydrolyzes the natural glucosides: aesculin amygdalin, androsin, arbutin, aucubin, bankanosin, calmatambin, coni-

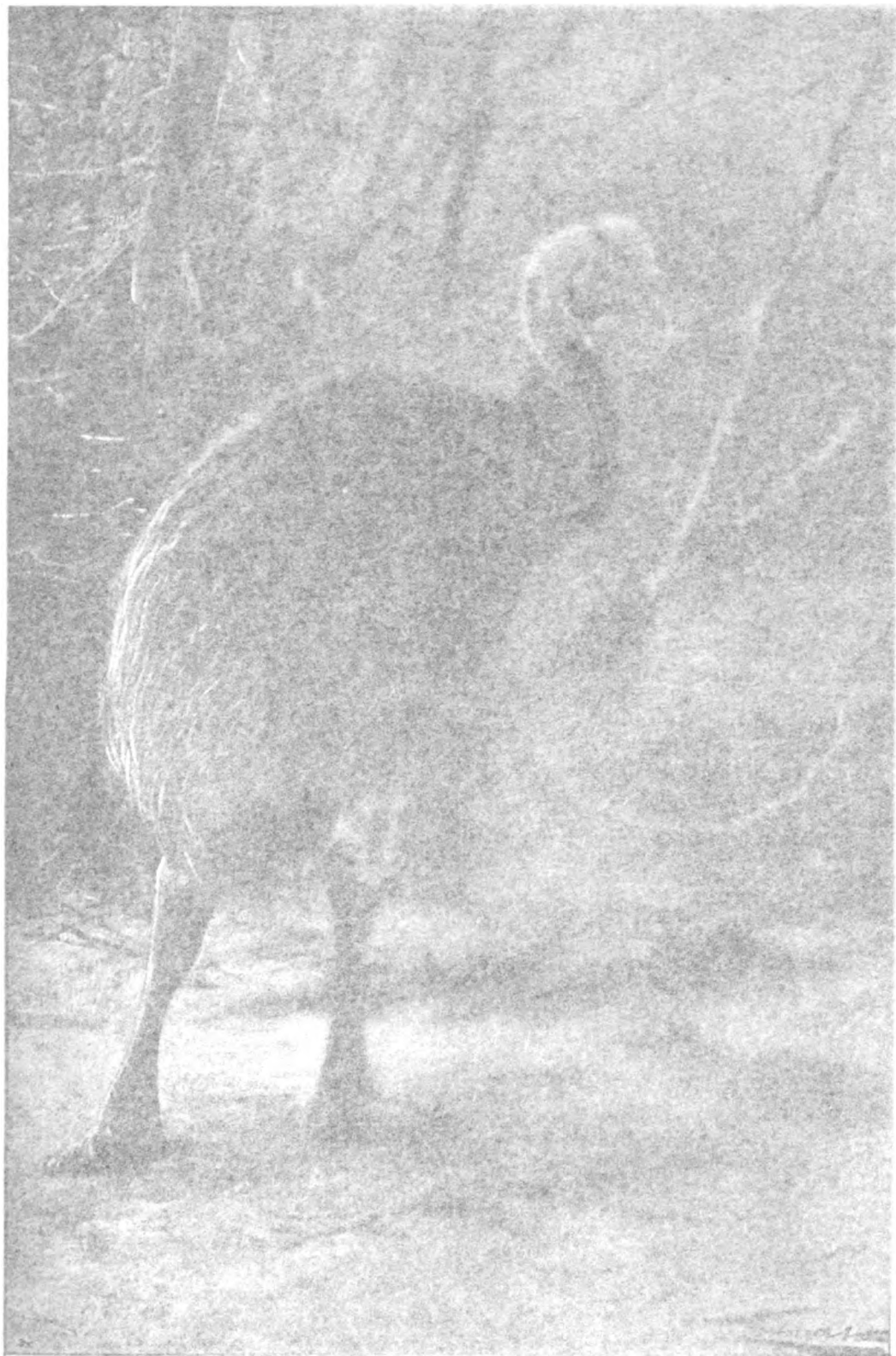



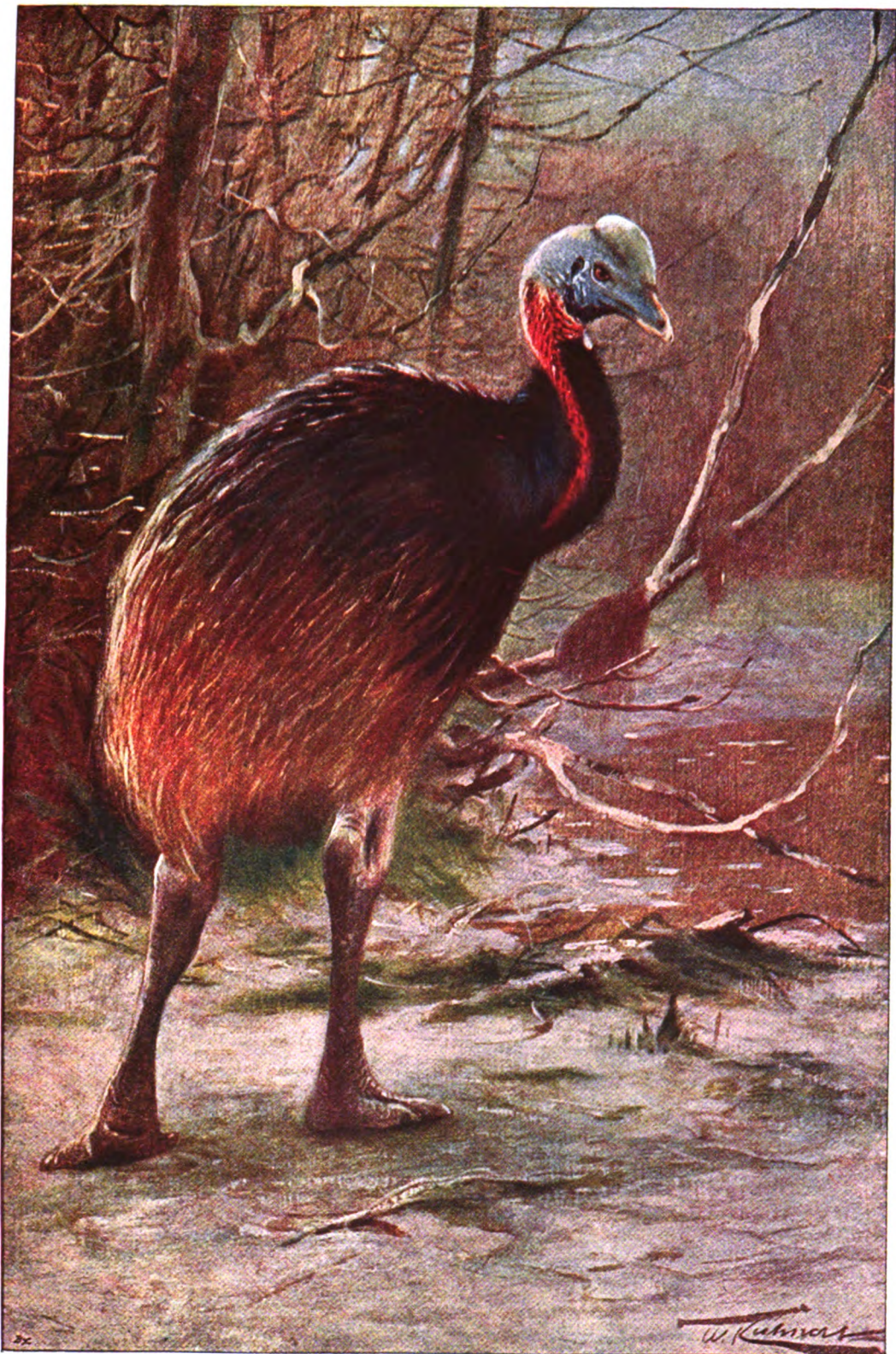

EMU (*Hippalectryo Uniappendiculatus*)





ferin, daphnin, dhurrin, gentiopicrin, helicin, incarnatin, indican, mandelonitrile glucoside, meliatin, oleuropein, picein, prulaurasin, salicin, sambunigrin, syringin, taxicatin and verbenalin, and the synthetic  $\beta$ -glucosides.

Emulsin is prepared by digesting the oil-free pulp of ground sweet almonds with a little toluene or chloroform for several hours, generally overnight. The whole is then put into a cloth bag and the liquid pressed out. This is treated with acetic acid, drop by drop, until the protein has been all precipitated. The clear liquid is treated with alcohol in repeated small quantities until no more precipitate falls. Pouring off the liquid the precipitate is hurriedly washed with absolute alcohol and ether to remove all moisture. It is then thoroughly dried in a vacuum to a soft white powder. Consult Armstrong, E. F., 'Lactase, Maltase and Emulsin' (London 1912).

**EMULSION**, the term applied to those preparations in pharmacy in which oily substances are suspended in water by means of gum, sugar, carrageen, etc., called emulsifiers. In general it will be found that the bulk of the emulsifier must first be taken, while the oil should only be added little by little, rubbing together in a mortar, and taking care that it is completely absorbed or emulsified before further additions. Should too much be added, the effect is to throw out most of what has already been incorporated; it is then practically impossible to remedy the error. The emulsion of cod-liver oil is familiarly known. Milk and the yolk of eggs are natural emulsions. The name is also given to suspensions in water of certain insoluble substances, such as resins. These being reduced to impalpable form are mixed with a syrup of gum or sugar, or other viscid fluid thick enough to prevent their settling. A familiar instance of this form of emulsion is common coal tar, which appears black because of the particles of free carbon suspended in the colorless pitch.

**ENAMBUC**, ä-nöñ-bük, or **ESNAMBUC**, Pierre, French navigator: b. Dieppe about 1570; d. Saint Christopher, W. I., December 1636. Being of an adventurous spirit, he sailed from Dieppe in 1625 in a brigantine of eight guns, for the Antilles. He landed in the island of Saint Christopher on the same day with a party of English colonists, with whom he divided the island, and, until his death, held the French half of the colony with extraordinary tenacity. In 1635 he took possession of Martinique, in the name of the king of France, and founded the town of Saint Pierre (q.v.).

**ENAMELS AND ENAMELING**. The term enamel is used for certain siliceous compounds employed for coating metals. They are, in every sense of the word, glass, either transparent, opaque, white or colored. The art is a very ancient one, some claiming it originated with the Scythians, who are said to have introduced it into China during the reign of a certain Emperor Thaiwonti, but India was acquainted with the art before China. Extant evidence exists that the ancient Egyptians, Phœnicians and Assyrians used enamel coating in the decoration of jewelry, and of the clay beads and scarabs of the Nile-dwellers in our museums many are covered with colored glass. The subject of enamel work on the precious

metals is discussed in another article (see **ART ENAMELS**), so we will confine this article to the technical side of enamel production and the industrial utilization of enamel.

**Raw Materials**.—The ingredients used in the production of the different kinds of enamels are felspar, quartz, fluorspar, borax, boric acid, soda, potash, saltpetre, cryolite, clays, ammonium carbonate, stannic oxide and water. The coloring agents used are cobalt oxide, limonite, iron oxides, chromic oxide, cupric oxide, etc. The felspar composition most desirable consists of siliceous earth 65 per cent, alumina 18 per cent, alkalis 16 per cent. For the creation of white enamels it is essential that the felspar shall be as free from iron oxide especially, as possible. Quartz must be pure but it is frequently replaced beneficially with a fine white river sand, which is pure quartz. Fluorspar or calcium fluoride of the purest quality only can be used, for white enamels especially. The borax needed for enamels is of the monoclinic system of crystallization (containing 10 molecules water of crystallization) not the octahedral crystals regular system, which contain only five molecules water. It is used as a flux or accelerator of fusion. Boric acid functions the same as borax but the former is more frequently used than the latter. Soda and potash have identical action in enamels and their presence heightens the lustre if it is not used too freely. The soda of commerce, being cheaper, is mostly employed; it is first calcined to obtain its anhydrous condition, then finely powdered. Saltpetre (nitre) used is the sodium variety, being cheaper than the potassium salt. It is used chiefly to decolorize; little or none at all is needed in the blue enamels. Cryolite used in the enamel industry may be either the natural or the artificial. This sodium-aluminum-fluoride is utilized for its double reaction of acting as flux and creating opalescence. Ammonium carbonate is supposed by some to be a valuable ingredient to inhibit cracking or crazing of the enamel in firing on account of its making the substance more uniform. Some authorities, however, declare its use a waste of money and useless. Stannic oxide is expensive with the present prices of tin but its use continues as a necessity after many attempts with substitutes. Care must be taken in maintaining the purity of the metal while in the oxidizing process or small black spots will appear in the baked enamel from impurities or may occur from particles of metal not having become oxidized. This chemical produces perfect opacity, which antimony substitutes do not, unless sufficient be used to cause other defects. The poisonous character of antimony has also caused its use to be forbidden in many countries. Lead oxide lends a wonderful brilliance to enamels; it acts also as a flux of great power. The lead oxides were formerly used considerably on earthenware utensils to assist the glaze, but long since they have been eliminated by law on account of their poisonous nature, their solubility rendering them extremely injurious when used on vessels for cooking, or even containing, food-stuffs. The use of the lead oxides is, therefore, restricted to the glazes of ornaments and art work.

**Coloring Matters**.—Cobalt oxide affords an intense blue color when used in strength and can be reduced in tone in lesser proportions.

Aside from its use in pigment cobalt oxide has the physical value of adhesiveness to sheet iron through its coefficient of expansion being the same as sheet iron. It, therefore, forms an ideal ingredient for the enamels used in cooking utensils. Perhaps it is here necessary to the uninitiated to state that one of the first requirements in an efficient enamel body is that it shall adhere to the metal under the stress of changes of temperature. On account of the high cost of cobalt nickel oxide is much used, through its considerably lower price. Limonite is a peroxide of manganese (called also pyrolusite) and is used in enamels to bleach out any impurity of tone in the white enamels. Additional proportions will produce dark violet (the noted *manganese violet* of the ceramist) and mixing a proportion of iron oxide with the limonite gives beautiful brown to black effects. Limonite in small proportions is sometimes blended with the more costly cobalt, producing a reddish blue of much brilliancy. Ferric oxide may be prepared to produce either a bright red or a reddish violet pigment according to the amount of heat applied in its manufacture. Chromic oxide produces a green enamel and cupric oxide gives a dark-green and a bluish-green; again a bluish-green can be obtained by a combination of copper and cobalt salts or chromium and copper salts, varying from bluish-green to greenish-blue according to their equivalents in the mixture. The salts of chromium, cadmium, uranium and titanium can each be used in obtaining yellow enamels. Ferrous chromate produces a lovely brown; it is called Brongniart's brown, after the great French ceramic chemist. Nickel is used in obtaining a gray enamel. The salts of gold produce a beautiful rose enamel as well as the loveliest pink. But a far less expensive pink is produced by chalk, quartz, stannic oxide, borax and bichromate of potash mixed and heated to a frit, the pigment being dissolved in water to separate it from the solids. Antimony produces several yellows including the noted Naples yellow (lead antimonate) of the art porcelains; they are, however, poisonous and forbidden in food utensils.

**Enamel Manufacture.**—In the mixing operations only absolutely trustworthy operators are employed. The working formulæ are kept strictly secret from all but the highest officials. From this point our description will be devoted to practices applied in the sheet iron and steel enamel industry. Every ingredient has to be dry and the degree of pulverization cannot be too fine to obtain a homogeneous enamel. The same care and time has to be given to the process of mixing the different ingredients. The French machine (*mélangeur*) does very effective work. The various chemicals are kept in separate bins, and, in order to maintain secrecy, each ingredient is known only under a letter or number. Taking the raw material from the bins it is loaded into small cars termed "dollies," which are loaded to a height approximating the quantity, then run on to a scale and weighed and the excess shoveled back or fresh added. The precaution is taken to have the scale beam and its graduation marks invisible to all but the person presiding over the work. With the completion of loading all the different materials in correct proportions in their individual "dollies" the material is mixed on a hard maple floor of the machine. First comes

the coarser material at bottom, the finest on top. The mixture made, it is hoisted by an electric elevator and run to its bin and the process is renewed in preparing the next kind of enamel, again to be stowed in its special bin. By means of a traveling bucket holding the correct amount for a melt the mixed raw material (about 1,200 pounds) is carried to the blast furnace (rarely a crucible furnace). The kind of furnace common in American use is the same that is used in the manufacture of glass and is heated with natural gas or crude oil as the most economical fuel, though coal is used in the older factories. The furnace temperature has to be very carefully regulated as insufficient heat produces a slow melt liable to create a decomposition, whereas too high a degree may create combustion or some chemical reaction injurious to the outcome. Some authorities place 1,000° C. for a glaze heat and about 1,300° C. for a ground coat. Control over the heat is permitted by the installation of pyrometers. A furnace can afford from seven to eight melts in 24 hours. As the ingredients fuse separately according to their different melting points great care has to be taken that the mixed mass be kept stirred lest they separate. The length of time needed for the smelt differs according to the enamels, a white fusing well at two hours while ground enamels and blues take from two-and-a-half to three hours, and so forth. The enamel is now a liquid glass, in which state it is drawn off by releasing a fire-clay plug located in the front of the furnace. The molten body flows into a tank of cold water and, with noisy reaction, the vitreous liquid is torn into shreds and small pieces with explosive violence, leaving minute fissures throughout the substance. Besides toughening the enamel body this so-called "quenching" assists in easing the next process, which is grinding. This grinding cannot be too fine, in fact the finer the resulting impalpable powder the brighter the resulting lustre of the enamel. The suddenly quenched glassy mass is known as a "frit." During the grinding other materials are added, such as stannic acid for creating an opaque white, or pigments for the different colors. About 30 hours is required for grinding in the large ball mills. The latter are cylindrical, about five feet in length and have a diameter of about six feet, and are lined with porcelain bricks. To the frit, which should retain about 50 per cent of water, is added a small percentage of white ball-clay. About 2 per cent zinc oxide improves a white. The clay addition is made to help hold the other ingredients in suspension, hindering them from subsiding according to their specific gravities; it also creates opacity, increasing at the same time, the needed quality of elasticity of the enamel. Other additions are added in proportions in accord with the secret formulæ, such as sal-ammoniac, ammonium-carbonate, magnesium-chloride, burnt magnesia, chloride of sodium (table salt), borax, soda, etc. The ground mass should reach the consistency of a rich cream, when it is poured into tanks and left to mature for a week or more.

**Formulæ.**—A German formula for a white enamel is (in kilogram equivalents) borax, 132; quartz, 152; felspar, 130; soda, 26; salt-petre, 6; cryolite, 78; fluorspar, 3; magnesia, 6. An acid-resisting enamel white is borax, 74;

felspar, 100; quartz, 115; cryolite, 47; stannic oxide, 40; fluorspar, 6; soda, 20; saltpetre, 10; magnesium carbonate, 1; pure powdered glass-meal, 53; clay, 12; calcspar, 6. A blue enamel formula is borax, 60.0; alumina, 3.6; felspar, 101.0; soda, 6.2; natural cryolite, 24.0; saltpetre, 3.0; fused enamel fragmentary, 40.0; cobalt oxide, 3.0; limonite, 0.3; ferric oxide, 0.1. A black fused enamel formula is borax, 62; felspar, 120; soda, 14; ferric oxide, 8; cobalt oxide, 2; smalt, 16; limonite, 16.

**The Metal and Treatment.**—In the production of steel enameled kitchen utensils the metal should be as free as possible from sulphur, carbon, silicon or phosphorus and with a general manganese content of about 0.2 per cent. The sheets (oblong or square) run from 27 to 20 gauge. Applying as little heat as possible, they are circled, stamped and spun, using a lubricant that is easily eliminated. A pickling process must, of course, cleanse the metal from impurities before the shaping is done. The additional trimmings (ears, handles, etc.) should be welded on because the enameling of riveted parts is a difficult process.

**The Enameling Process.**—The operation as carried on in American factories is clearly described by R. D. Landrum, an expert. This work starts in the "dipping room," where the liquid enamel is placed in tanks of dish-pan form sunk into tables. The operator, called a "slusher," dips the stamped steel vessel (which has been previously cleansed of all grease and impurities) into the enamel. Coming out of the immersion the vessel is covered with a film of the wet enamel, any drip or excess is eliminated by the slusher gently swinging the object, when it is placed, bottom down, on three metal points that project from a board. After several vessels are placed on the board it is set in a rack, and, when dry and the rack full, they are conveyed to the furnace room, where a bank of muffle ovens receives them. The temperature (about 1,000° C.) here fuses the minute powdered particles of enamel together into a glass coating covering the entire vessel, a process requiring but three to five minutes. Other coats are added, as needed, over this ground coat. In a three-coat piece we wish, perhaps, three coats of white on the inside and turquoise-blue outside. The ground coat enamel having dried and been passed through the oven comes out almost black, from the cobalt and nickel oxides, and the piece is left to cool. The slushing room operator now gives the vessel an immersion in white enamel and adds a black "bead" or edge on the rim. This second coat still shows up grayish as the first coat penetrates through after firing, so it is subjected to another dip at the hands of the slusher in the white enamel. A spray of blue-green enamel is applied to the outside, before drying, with the aid of a wire brush, or the more up-to-date machine which acts as an atomizer. The vessel is next dried and fired again in the oven, leaving turquoise blue spots outside on the white background. The next process is the assorting of the finished wares into "firsts," "seconds" and "thirds" or job lots, according to their perfection or defects. Imperfection in the cleaning of the original vessel may have caused minute spots to appear on the surface, due to rust or dirt. This defect can sometimes be remedied by filing the spots off, or subjecting them to a sand-blast,

and giving the vessel another coat of enamel. The discovery, or invention, of applying enamel coatings to metal ware such as kitchen utensils, bathtubs, etc., in the same manner as the bath tiles and earthen utensils which had been used by our fathers was indeed opportune, for the rising price of the metal had made the process of tinning so exorbitant that the industry was in real distress, with the certain prospect of the price of tin advancing to much higher proportions. The iron-enamel industry has extended its lines into sanitary ware, hygienic implements, chemical apparatus and numerous other branches. The growth of the industry, starting principally in France and Germany on a large scale, has extended to the United States, all in the course of about 25 years. The German output, by 1909 already, was 90,000,000 kilos, employing a capital of near \$15,000,000. In 1914 the industry in Germany and Austria-Hungary employed in the neighborhood of 60,000 wage earners. In the United States the 'Census of Manufactures' (1914), gives us the following interesting statistics of the sheet iron and steel enamel industry. There were 270 factories, employing 28,731 operators. They produced goods valued at \$68,979,005, and had a payroll of \$15,242,586. Consult Gruenwald, J., 'The Theory and Practice of Enameling on Iron and Steel' (translation by H. H. Hodgson, London 1909); id., 'The Raw Materials for the Enamel Industry and their Chemical Technology' (London 1914); Landrum, R. D., 'Enamels' (Cleveland 1918); Millenet, L. E., 'Manuel pratique de l'émaillerie sur métaux' (Paris 1917).

CLEMENT W. COUMBE.

**ENARA**, ä-nä'rä, or **ENARE**, ä-nä'rä, a lake in Finland; area, about 145 square miles. The outlet is Patsjoki River, which flows into the Arctic Ocean. A town of the same name, at the southwest extremity, is inhabited chiefly by fishermen.

**ENAREA**, ë-nä'rë-ä, a country of the Gallas, south from Abyssinia, between lat. 7° and 8° N., and long. 35° and 37° E. In the valley of the Gibbi, immediately beyond Sakha, the chief town of the country, are extensive plantations of coffee, which, along with ivory, is largely exported. The inhabitants are the most civilized of the Gallas, and show much skill in manufactures. Pop. about 40,000.

**ENARGITE**, en-är'jit, a native sulpharsenate of copper, of which it contains 48.3 per cent. It constitutes an important ore of copper and is found in cleavable-granular masses, also in orthorhombic crystals. It has eminent prismatic cleavage, a brilliant metallic lustre, and grayish-black color and streak. Its hardness is 3 and specific gravity 4.44. It is common in Chile, Peru, Mexico, South Carolina, Colorado, Utah, California and Montana.

**ENAUULT**, ä'nö, Louis, French novelist: b. Isigny, Calvados, 1824; d. Paris 1900. He used the pen-name "Louis Vermont." He wrote many novels and books of travel, including among them, 'Promenade en Belgique et sur les bords du Rhin' (1852); 'La terre sainte' (1854); 'Constantinople et la Turquie' (1855); 'Voyage en Paponie et en Norvège' (1857); 'La Méditerranée, ses îles et ses bords' (1862); 'L'Amérique centrale et meridionale' (1866); 'Paris brûlé par la Commune' (1871);

'Valneige' (1887); 'Le Château des anges' (1891); 'Tragiques amours' (1891); 'Jours d'épreuve' (1894); 'La tresse bleue' (1896); 'Myrto' (1898); and a French translation of 'Uncle Tom's Cabin' (1853).

**ENCÆNIA**, ěn-sĕ'ni-a, or **ENCENIA**, a name given to the feast in commemoration of the dedication or consecration of Christian churches. In early times it was applied to the feast in honor of the founding of a city as well as in honor of the founding, or taking possession by dedication or consecration, of churches. The custom of observing the anniversary of the consecration of a church or cathedral dates from the time of Constantine, when Christians were permitted more freedom of worship in the Roman territory; but the Jews before the coming of Christ solemnly dedicated their tabernacles; and in a certain sense, consecrated their houses of worship. The Christian ceremonies became very elaborate on these occasions and were disapproved and finally modified. The name is applied also to commemorating festivals in honor of the founders and benefactors of Oxford and Cambridge universities. At Oxford University "Commemoration," or "Encenia," usually takes place the third Wednesday after Trinity Sunday. The oration in honor of the founders and benefactors is given in Latin.

**ENCALADA**, ān-sā-lā'dā, **Manuel Blanco**, Chilean soldier and statesman: b. Buenos Aires, Argentina, 1790; d. Santiago, Chile, 5 Sept. 1876. He studied at Madrid, and in the Naval Academy at Leon, and after deserting from the Spanish ranks joined the Chilean revolutionary party, and served with distinction both in the artillery and in the navy. He became rear-admiral in 1819, and major-general of infantry in 1820; and in 1825 was appointed head of the army of Chile. He was for two months President of the republic in 1826, governor of Valparaiso 1847-52, and Minister to France 1853-58.

**ENCAMPMENT**, the military camp in its more comprehensive sense, including the occupants of the camp proper, as well as the physical equipment collected and arranged to shelter and provide for them. In military parlance the shorter term "camp" is used to embrace the whole significance of the term encampment — which therefore has lapsed to a greater or less degree into disuse, except among the romantic writers. See **CAMP**.

**ENCAUSTIC**. See **MURAL PAINTING**.

**ENCAUSTIC PAINTING**. See **PAINTING, TECHNIQUE OF**.

**ENCAUSTIC TILES**, a species of ornamental tiles made of a finer kind of clay than the ordinary tiles, but not so fine as porcelain. These are of two sorts: plain and figured. The plain tiles are sometimes square, but more frequently triangular and of different colors; the latter shape renders possible a greater number of designs when the tiles are employed in a sort of mosaic work for the paving of churches, halls, etc. They are made by putting the colored clay into strong steel molds and subjecting it to a pressure of several hundred tons, by means of a plunger fitting accurately into the mold. The under surface of the tile is usually ribbed in order to afford a better hold for

mortar. The clay for figured tiles is pressed into an iron mold, the bottom of which is formed of a plaster of Paris pattern, bearing the desired design. The pattern being removed, the depressions on the surface of the tile are filled with colored clays, and the surface is then shaved to remove all superfluities and ruggedness, leaving the pattern intact. The tile is then dried for two or three weeks and finally fired by being exposed to an intense heat for 60 hours.

**ENCEINTE**, ɔn-sānt, in military engineering and in fortification, the continuous line of works which forms the main enclosure of a town or fortress. The term is also applied to the area within this line.

**ENCELADUS**, son of Tartarus and Gæa in Greek mythology; one of the hundred-handed Titans who made war against the gods. Jupiter slew him with a thunderbolt and burned him under Mount Ætna. The name Enceladus was given to the second satellite of Saturn, discovered by Herschel 28 Aug. 1789.

**ENCEPHALITIS**, an inflammation of the brain proper which may be localized or diffused, and results from coexistent intoxications, or following any acute affection such as ulcerative endocarditis, rheumatism, mumps, etc. It is quite probable that many cases of acute encephalitis occur in children, resulting in the well-known picture of infantile hemiplegia. The symptoms are very indefinite. There is headache, vomiting, somnolence. There may be coma or delirium, the symptoms all pointing to acute inflammation of the brain. Acute encephalitis is usually fatal. In many of the insanities, as acute mania, delirium, dementia paralytica, there is a form of encephalitis usually present. Localized encephalitis usually results in abscess. See **BRAIN, DISEASES OF THE**.

**ENCEPHALOCÉLE**, ěn-sĕf'ā-lō-sĕl, a hernia or a protrusion of a portion of the contents of the cavity of the brain through an opening in the skull beneath the skin. At least three different forms are described: Meningocele, when the dura mater alone protrudes from the cavity, forced out by the pressure of the cerebrospinal fluid; hydrocephalocele, in which the tumor consists of an internal hydrocephalus; and encephalocele, which is made up of true brain-tissue with more or less fluid surrounding it. Most of these tumors are of congenital origin, due to insufficient union of the bones of the skull; a few are acquired later in life. Surgical procedure is the only efficient mode of treatment.

**ENCEPHALON**, the contents of the skull. See **BRAIN**.

**ENCHANTER'S NIGHTSHADE**, a name common to plants of the genus *Circea*, belonging to the family *Onagraceæ*, of which there are three American species, *C. lutetiana*, *C. pacifica* and *C. alpina*. The first is about a foot and a half high, and has delicate ovate leaves, small white flowers tinged with pink, and small roundish seed-vessels covered with hooked bristles. It abounds in woods from Nova Scotia to western Ontario, south to Georgia and west to Nebraska. It is also called the bindweed nightshade. *C. alpina*, which is similar but smaller and more delicate, is found in cold, moist shady woods throughout the north-

ern hemisphere. Both plants are common in Europe and Asia. Neither has any affinity with the true nightshades.

**ENCHASING**, or **CHASING**, the art of enriching, beautifying and finishing ornamental designs in raised work upon metal surfaces, especially gold and silver. When these designs have received their general form by casting or hammering they are ready for the skilled hand of the artisan and his chasing tools. These are of a great variety of shapes and sizes, fitted to correspond with the minute details of the most complex work. Some are grooved or checkered at the ends, and some of the gravers and burins are curved and blunt, while others taper to a needlepoint. The worker possesses a set of hammers, big and little, graded in size to suit any kind of tool. To offset his alternating task of punching and carving he employs sand bags upon which to rest his work. In order that the form of hollow articles may not suffer injury during the operations they are filled with a composition of melted pitch and brick dust or rosin. Articles in copper and brass are sometimes filled with lead to give them firm support within. Fine steel blocks are often used to the same end. Excellent specimens of chased work are seen in pieces of ancient armor, and in vases and other ornaments in gold and silver-plate. Among the most beautiful are those executed by Benvenuto Cellini (q.v.) in the 16th century. Bronze, richly wrought, has taken its place beside gold and silver work.

**ENCINA**, ɛn-thě'nā, **Juan del**, Spanish dramatist: b. La Encina, Spain, 1469; d. there 1534. Little is known of his life; the probable facts are that he was educated at Salamanca, and in 1492 became a member of the household of the Duke of Alba, under whose patronage he began to write his plays. He was appointed *mæstro di cappella* to Leo X at Rome, took orders and was ordained prior at León. His first volume of poems, 'The Song-Book,' contained also a dissertation on 'The Art of Castillian Poesy.' His lyrics are full of charm and lively wit. He wrote 14 dramas, eight of which are shepherd-plays or eclogues; the rest are pieces for church holy seasons. It is to the former that he owes his position in Spanish literature, for these homely scenes were the first secular plays in Spain. He made the Jerusalem pilgrimage, and described it in the poem 'Tribagia; or, the Sacred Way of Jerusalem' (1521). He has been styled "The father of the Spanish drama." His dramatic works were edited by Asenjo Barbieri, in 'Teatro Completo' (Madrid 1893); his lyrics by Francisco Asenjo Barbieri in 'Cancionero musical de los siglos XV y XVI' (Madrid 1894). Consult Díaz Jiménez y Molleda 'Juan del Encina en León' (Madrid 1909).

**ENCISO**, ɛn-thě'sō, **Martin Fernandez de**, Spanish geographer: b. Seville, about 1470; d. after 1528. He came to America in 1500; practised law in Santo Domingo and supplied funds to Alonso de Ojeda for the colonization of Tierra Firme, the region about the Isthmus 1509. Enciso followed in 1510 and founded the city Santa Maria la Antiqua del Darien. His soldiers revolting, he was arrested by Vasco Nuñez de Balboa, and went to Spain, returning to Darien 1514 as *alcalde*, and opposing Balboa

till the latter's unjust execution by Pedrarias Davila at Darien 1517. He was the author of 'Suma de Geographia, que trata de todas las partidas del mundo,' the first Spanish description of America which touched upon the difference in level of the two oceans.

**ENCCKE**, ɛng'kē, **Erdmann**, German sculptor: b. Berlin, 20 Jan. 1843; d. 1896. He was a pupil of the Berlin Academy and of Albert Wolff, his first piece being a group entitled 'A German Struggling With Two Gauls.' He took a prize for the statue of Jahn in 1872, and was made professor at the Berlin Academy in 1883. His art was related to the school of Rauch, his temperament being at the same time realistic and poetical. Among his prominent works are a statue of the Great Elector, Frederick I of Brandenburg (Town Hall, Berlin); a colossal statue of Queen Louise of Prussia (Thiergarten, Berlin); and the sarcophagi of Emperor William I and Empress Augusta in the mausoleum at Charlottenburg.

**ENCCKE**, **Johann Franz**, German astronomer: b. Hamburg 23 Sept. 1791; d. Spandau, 26 Aug. 1865. He studied under the astronomer Gauss, at Göttingen; during the war of liberation (1813-15) served as artilleryman in the German army, and on the conclusion of peace was appointed assistant in the observatory of Seeberg, near Gotha. Here he calculated the orbit of the comet observed by Mechain, in 1786, by Miss Herschel in 1795, and by Pons in 1805-18. He predicted its return in 1822-25-28, and with each reappearance more data were afforded for computing its exact orbit, which, it was calculated, required three and a quarter years to complete. By comparison of the times of its earlier and later appearances, Encke was subsequently led to detect a gradual acceleration of its movement, amounting to about two and a half hours on each revolution. This acceleration he ascribed to a resisting medium, which sensibly affects the body of the extreme rarity of this comet, which is transparent to its centre. The fame of his two publications 'Die Entfernung der Sonne' (1822), and 'Der Venusdurchgang von 1769' (1824), led to his appointment as director of the observatory of Berlin (1825), a position which he held till his death. Many of his works are contained in the 'Astronomische Jahrbücher' (1830-66), a publication during these years issued under his direction. His various scientific publications were collected and published as 'Gesammelte mathematische und astronomische Abhandlungen' (3 vols., Berlin 1889); and 'Astronomische Abhandlungen' (3 vols., Berlin 1868).

**ENCLOSURE**, or conventual seclusion of nuns who have taken solemn lifetime vows, is guarded very strictly by the laws of the Roman Catholic Church. The conventional seclusion of monks is less strict, the prohibition of converse with the outer world being in their case limited to the exclusion of women from the interior of the monasteries and rigid rules on the observance of silence. The Council of Trent forbids nuns to leave their convents, even for a short time, on any account whatever save for a legitimate cause—a cause specified in the law—with the approval of the local bishop. And no person from outside, male or female,

young or old, high or low, lay or clerical, is to be admitted within the *clausura* of a nunnery unless with leave in writing from the bishop or superior. By violation of this rule excommunication is incurred ipso-facto. These rules, however, apply to regularly cloistered nuns, who take solemn life-vows of detachment from the world: they do not apply to the houses or convents of religious women whose work brings them in contact with the outside world, such as Sisters of Charity, of Mercy, Little Sisters of the Poor and the like. In such religious institutes the spirit of the Tridentine law governs, not the letter.

**ENCRATITES**, ěn-křá'ti-tēs (*continentes*, abstainers), a Gnostic sect of the 2d century, disciples of Tatianus, who was himself a disciple of Justin Martyr, and, like him, author of an *Apologia* on behalf of Christian believers. Tatianus held that the material world is essentially evil, proceeding from the evil principle. For him marriage was sinful and animal food an abomination; he employed water instead of wine in the eucharistic rite.

**ENCRINITES**, ěn-kři-n'ťtěz, a division of fossil crinoids or so-called "stone-lilies" distinguished from the more common forms with angular stems (*pentacrinites*) by having stems whose cross section was circular or oval. The Derbyshire "birdseye" marble is noted for the vast numbers of encrinital remains it contains, the silicon skeletons appearing in the polished stone as if in relief. See CRINOID.

**ENCYCLICAL** (*literæ encyclicæ*), a circular letter. The word used in an ecclesiastical sense means a letter addressed by the Pope to all the bishops in the world who are in communion with him, in which he condemns errors prevalent in the world, or explains the line of conduct which Christians ought to take in reference to practical questions pertaining to faith and morals. Pius IX was the author of a renowned encyclical which noted 80 prime errors in current thought. Leo XIII issued a large number of encyclicals on such questions as, rights of labor, education, marriage, Bible study, etc., and Pius X in 1907 condemned certain trends of modern thought and actions. An encyclical differs from a bull or brief, in that the encyclical is to the bishops of the whole world, treats of matter of universal interest and is of concern to the entire Church. A bull or brief is determined by circumstances, is of a special nature and may be of particular value only to some locality. There is a difference in the form of an encyclical from that of a bull or brief,—that is, in the seals used, the signatures and the introductory words.

**ENCYCLOPÆDIA, CYCLOPÆDIA, or CYCLOPEDIA.** This word, formed from the Greek *en*, in, *kuklos*, a circle, and *paideia*, instruction, but not a native Greek compound, originally denoted the whole circle of the various branches of knowledge which were comprehended by the ancients in a liberal education (the *artes liberales* of the Romans). The distinction between the words encyclopædia and cyclopædia is almost too trifling to be comprehended. At a later period the word was applied to every systematic view, either of the whole extent of human knowledge or of particular departments of it. The want of such

general surveys was early felt; and as knowledge increased they became still more desirable, partly for the purpose of having a systematic arrangement of the sciences in their mutual relations, partly for the readier finding of particular subjects; and, for these two reasons, such works were sometimes philosophically, sometimes alphabetically, arranged. The spirit of compiling, which prevailed in the Alexandrian School, soon led to attempts remotely allied to this, and Varro and Pliny the Elder, among the Romans, composed works of a similar kind.

The honor of undertaking encyclopædias on a regular plan belongs to the Middle Ages, which produced not only a large number of cyclopædias of particular sciences, called *Summæ* or *Specula* (for example, the 'Summa Theologiæ' of Thomas Aquinas), but also a Universal Encyclopædia, such as had never been seen before. The indefatigable Dominican, Vincent of Beauvais, about the middle of the 13th century, exhibited the whole sum of the knowledge of the Middle Ages in a work—or rather three works—of considerable size—a real treasure to the inquirer into the literary history of the Middle Ages. An exceedingly popular work was the 'De Proprietatibus Rerum' of Bartholomeus de Glanvilla, an English Franciscan friar, which maintained its reputation from the year 1360 to the middle of the 16th century. In the 17th century various encyclopædic works were compiled, such as the Latin one of John Henry Alsted, 'Encyclopædia vii Tomis distincta' (Herborn 1620), a work in which the subjects are divided into 7 classes, and treated in 35 books. In 1674 appeared the first edition of Moréri's 'Le Grand Dictionnaire Historique.' In 1677 John Jacob Hoffman published at Basel his 'Lexicon Universale,' the first work of the kind in which a summary of art and science was presented in dictionary form. In 1697 appeared Bayle's famous 'Dictionnaire Historique et Critique' (Rotterdam, 4 vols.), a work which is still of great value. Among the greatest works of earlier date would have been reckoned the 'Biblioteca Universale' of Coronelli, had it been completed according to the original plan. It was to have appeared in 45 folio volumes, of which only seven were published (Venice 1701-06). More successful, especially in being brought to a completion, was the 'Grosses vollständiges Universallexicon aller Wissenschaften und Künste' (Grand Universal Lexicon of all the Arts and Sciences), commonly called Zedler's, from the person, a bookseller, who conducted it (Halle and Leipzig 1732-50, 64 vols.; Supplement 1751-54, 4 vols. folio). It has, on the whole, much merit. Lives of living men were included after volume XVIII.

The transition from the ancient type to the modern occurred about the middle of the 17th century and originated in the desire to make books of this kind more easy of consultation. This changed the arrangement of the material by classified subjects to its alphabetical arrangement by key words, names or special topics. The encyclopædia thus approached and was assimilated to the dictionary. The change was not confined to the form, for the alphabetical arrangement inevitably led to a change in the purpose and character of encyclopædic compilation, viz., that from the exposition of the system

of human knowledge to the mechanical arrangement of its contents. In this line of its development the encyclopædia became a work of reference in the strict sense of that word—a work for occasional use, in which any particular topic or item of information desired can be found under the proper word in an alphabetical vocabulary. This practical aim and this method have, however, been adopted by modern encyclopædists in varying degrees. On the one hand, there has been a tendency to approach more and more closely to the dictionary type by increasing the number and variety of the vocabulary words, and correspondingly subdividing the material contained in the book; and, on the other, a tendency (traceable to the ancient systematic type) to restrict the vocabulary and combine the material as much as possible under comprehensive titles. In its extreme form the former tendency has given rise to the modern "encyclopædic dictionary," and the latter to encyclopædias which are little or nothing but aggregations of monographs.

In practice, however, encyclopædia makers incline more and more toward the adoption of the dictionary type, as better suited to the practical needs of scientific and literary workers and as, in fact, essential to the adequate presentation of the vast accumulations of modern science, history and biography. An important characteristic of modern methods is the employment of a large corps of specialists, both as compilers and as editors. In general it may be said that no good general encyclopædia is now possible which does not include in its editorial staff a small army of men of science, historians, theologians, lawyers, and so on. The aim is to collect at first hand the special knowledge of the time and to present it in a manner that is acceptable to specialists. Lastly, the use of pictorial illustrations—plates and diagrams and pictures in the text, which found a place in encyclopædias at an early date—has been extended and their quality improved.

The first encyclopædia written in English and with the articles alphabetically arranged was the 'Lexicon Technicum,' or a 'Universal English Dictionary of Arts and Sciences' (London 1704, 1 vol. folio), by John Harris, a London clergyman. This was a useful and popular work, though it omitted from its scope theology, biography, antiquity and poetry. It was reprinted in 1708 and a second volume was added in 1710. Among other important encyclopædic works in English the following may be mentioned: Ephraim Chamber's 'Cyclopædia'; or a 'Universal Dictionary of Arts and Sciences'—a work published in 1728, in two volumes folio. A second and improved edition came out in 1738. Latterly it was revised and enlarged by Abraham Rees, in which form it was several times reprinted, being finally known as 'Rees' Cyclopædia,' and published in a number of volumes. Then was published the 'Encyclopædia Britannica.' Of this there have been 11 editions. The first edition was completed in 1771, in three volumes and the 11th edition was completed in 1910–11 in 29 volumes and an index volume. The 'Edinburgh Encyclopædia' (1810–30, 18 vols.) was devoted particularly to the sciences and technology and was conducted by Sir David Brewster. The 'Encyclopædia Metropolitana' (London, begun 1815, completed 1845, in 25 vols., was published in four divi-

sions, according to a plan devised by the poet Coleridge). The 'London Encyclopædia,' by Thomas Curtis (22 vols.) and the 'Penny Cyclopædia' (29 vols.), appeared in 1833–46. Chambers' 'Encyclopædia' (in 10 vols.) was published in 1860 and a new edition appeared in 1902.

During the 19th century, the various branches of science and technology, history, biography, theology, commerce, politics, law, the fine arts, etc., are all admirably represented in special works; the growth of the special encyclopædia having kept pace with the advance of knowledge and of industry. Among the most important are the encyclopædias of biography. Some excellent examples of the special encyclopædia date from the 17th and 18th centuries; but those produced in the 19th century are much more numerous and, in several cases, far more comprehensive. The most notable of these later biographical works are the 'Biographie universelle ancienne et moderne' (85 vols., 1811–62, including supplement; 2d ed., 45 vols., 1842–65) of Joseph and Louis Gabriel Michaud; and the 'Dictionary of National Biography' (66 vols., 1st supplement, 3 vols., 1885–1901; 2d supplement, 3 vols., 1901–11; republished in 22 vols., 1913).

In the United States an early work in the general field was the 'Encyclopædia Americana,' edited by Francis Lieber and published 1st ed., 13 vols., 1829. 'The American Cyclopædia,' edited by George Ripley and Charles A. Dana, appeared in 1858–76 in 16 volumes. The publishers of this work have since 1861 published the 'American Annual Cyclopædia,' designed to record the progress of science and the arts, and the world's history from year to year, and to serve as supplements to the 'American Cyclopædia.' It is in the same form as that work, octavo, and comprises about 800 pages per volume. 'Johnson's New Universal Cyclopædia' first appeared in 1874–77, in four imperial octavo volumes. It was especially strong in the departments of natural science—physics, chemistry, mechanics, etc.—and American gazetteer matter. In its later form, 'Johnson's Universal Cyclopædia' (1893–95, 8 vols.), with a change of publishers, the work was thoroughly revised, by a corps of 36 editors, under the direction of Charles Kendall Adams. Then followed 'The International Cyclopædia' (New York 1884), which was succeeded by 'The New International Encyclopædia' in 20 volumes (1902; 2d ed., 24 vols., 1914), and later by the 'Encyclopedia Americana' (1st ed., 16 vols., 1903; 2d ed., 20 vols., 1906; 3d ed., 22 vols., 1910; new and enlarged edition, revised throughout, 30 vols., 1918).

Of the French cyclopædias the most famous is the great 'Encyclopédie, ou Dictionnaire Raisonné des Sciences, des Arts, et des Métiers,' by Diderot and D'Alembert. This was published in 35 volumes 1751–80. Not only information was given in these volumes, but opinions of the most radical character, hostile to the Church, subversive of religion, intensely antagonistic toward everything in the old order of things. The clergy and the court had fought the work, had even broken into it with alterations secretly made at the printers', and left no stone unturned to prevent its circulation. Yet Europe was filled with it and shaken with the effects of it. It was an immense burst of every-

thing which journalism to-day means; a fierce prophecy of changes which are still pending; a wild proclamation of the problems of human aspiration and desire. Not only were the sciences pushed to the utmost by Diderot, but he made industry, labor, human toil in the shop, an interest unceasingly cherished. It was an explosion heralding the Revolution a quarter of a century later. Still more comprehensive is the 'Encyclopédie Méthodique, ou par Ordre des Matières' (Paris 1781-1832, in 166½ vols.), an aggregate of dictionaries rather than a single work. The French have also the 'Encyclopédie Moderne,' begun in 1824, finished in 1832, 26 volumes, and subsequently republished; the 'Encyclopédie des Gens du Monde' (1835-44), 22 volumes; Larousse's more recent and valuable 'Grand Dictionnaire Universel du XIX Siècle,' 16 volumes folio (with two supplementary volumes); 'La Grande Encyclopédie,' an extensive and excellent work which was completed in 1903, and 'Dictionnaire encyclopédique universel, illustré de 20,000 figures,' edited by E. Flammarion and begun in 1895. Of works published in Germany the most famous is 'Brockhaus' Conversations-Lexikon,' now in its 14th edition. It is equaled, if not surpassed, by the similar work of Meyer. The huge 'Allgemeine Encyclopädie der Wissenschaften und Künste,' originally edited by Profs. J. S. Ersch and J. G. Gruber, begun 1818, is not yet completed. To 1916 168 volumes have been issued. Three sections of the alphabet are carried on simultaneously. Other German encyclopædias deserving mention are those of Pierer and Spamer.

In Italian, the 'Nuova Enciclopedia popolare' (14 vols., Turin, 1841-51); the 'Dizionario universale di scienze, lettere ed arti' (Milan 1874), by Lessona and Valle; the 'Enciclopedia popolare italiana' (ib. 1872), edited by Giovanni Berri, and 'Nuova enciclopedia italiana' (25 vols., Turin 1875-88), are the principal. In Spanish Mellando published the 'Enciclopedia moderna' (34 vols., with an atlas) at Madrid in 1848-51. Another Spanish work of note is Montaner y Simon, 'Diccionario enciclopédico Hispano-Americano de literatura, ciencias, y artes' (25 vols., Barcelona 1887-99); the greatest of all such works in Spanish is the new 'Enciclopedia Segui,' begun at Barcelona in 1907 and of which nine volumes had appeared up to 1916. The 'Diccionario popular historico, geographico, mythologico, etc.' (16 vols., Lisbon 1876-90), by Chaga; 'Diccionario universal portuguez illustrado,' by Zeforina, are the standard works in Portuguese. Other works deserving of notice are Salmonsens's 'Store illustrerede Konversationsleksikon' (19 vols., Copenhagen 1891-1911) in Danish; the 'Geillustreerde encyclopedie: woordenboek for wetenschap en kunst' (2d ed., 16 vols., Rotterdam 1884-88); 'Nordisk Familjebok' (Stockholm 1904-, 15 vols. to 1911); 'Entisiklopeditchesky Slovar' (41 vols., Petrograd 1890-1904) and 'Encyclopedya Powszechna, etc.' (16 vols., Warsaw 1898-1904).

The rapid advancement of the sciences and arts and the proportionately rapid communication between all civilized nations, have made a general acquaintance with many different branches of knowledge more necessary than ever before. This is one of the chief causes which have produced in our time so many en-

cyclopædias of various kinds, some very learned and others more adapted for the general reader; some embracing all the sciences and arts, others only single branches.

**END-BRAIN**, a name given to the front part of the brain, which corresponds to the fore-brain or telencephalon. See **BRAIN**.

**END-ORGANS**, important nerve-structures specially designed for particular purposes. Thus the taste-buds in the mouth and tongue, the touch-bulbs in the fingers and the muscle-plates in the muscles are special forms of nervous end-organs. There is a vast variety of nervous end-organs found in the special glands, such as the secretory glands of the skin, of the mucous membranes, in the liver, the spleen, the kidneys, etc.

**ENDE**, ɛn'dê, **Hermann**, German architect: b. Landsberg 1830; d. 1907. He studied at the Academy of Architecture at Berlin; made a tour of Europe, during which he studied all the great models. At Berlin, with Böckmann, he erected the Red Palace, Royal York Lodge, the Bank of Commerce, the Ethnological Museum and the buildings of the Zoological Gardens. In 1866 he designed several public buildings for the city of Tokio, Japan, at the behest of the Japanese government. From 1885 to 1901 he was chief professor in the High School for Technical Arts at Berlin. He was a member of the Berlin Academy of Arts and honorary member of those of Vienna and Saint Petersburg.

**ENDEMAN**, ɛn'dê mǎn, **Wilhelm**, German jurist: b. Marburg, Hesse, 24 April 1825. He studied at Heidelberg and was professor of law at Jena 1862-66 and at Bonn in 1867. He was a member of the Reichstag 1871-73. His writings on German commercial law are highly esteemed. Among his works are 'Die Beweislehre des Civilprozesses' (1860); 'Der deutsche Civilprozess' (1878-79); 'Die Entwicklung des Beweisverfahrens im deutschen Civilprozess' (1895).

**ENDEMIC** (Gr. "prevailing among the people"), a name often applied to diseases which attack the inhabitants of a particular district or country, and have their origin in some local cause, as the physical character of the place where they prevail, or in the employments, habits and mode of living of the people. Every part of the world, every climate and every country has its peculiar endemics. Thus the tropical and warm climates are subject to peculiar cutaneous disorders, eruptions of various kinds, because the constant heat keeps up a strong action of the skin. In northern climates eruptions of the skin occur, but they are of a different kind. Thus in all the north polar countries, especially in Norway, a kind of leprosy, the *radesyge*, is prevalent, arising from the coldness and humidity of the climate, which dispose the skin to such disorders. Hot and moist countries generate the most violent typhoid and putrid fevers; the West Indies and some of the South American coasts, for instance, produce the yellow fever. In different parts of the United States intermittent fevers, arising from local malarial conditions, are common, as they are in countries generally in places that are damp and not warm, on marshes and large rivers, etc. Places in a more dry and elevated situation, northern coun-



tries particularly, are peculiarly subject to inflammatory disorders. In countries and districts very much exposed to currents of wind, especially in mountainous places, we find at all seasons of the year rheumatism, catarrhs and the whole train of complaints which have their origin in a sudden stoppage of the functions of the skin. In large and populous towns we meet with the most numerous instances of pulmonary consumption. In cold and damp countries like England, Sweden and Holland the most frequent cases of croup occur.

Diseases which are endemic in one country may also appear in others and become epidemic if the weather and other physical influences resemble those which are the causes of the endemic in the former place; the climate being for a time transferred, as it were, from one to the other. Endemic disorders in some circumstances become contagious, and thereby spread to other persons, and may be transplanted to other places, the situation and circumstances of which predispose them to receive these disorders. This is known by the migrations of diseases, the spreading of leprosy from Oriental countries to Europe, and the like.

It is favorable to the cure of obstinate disorders for the invalid to remove to a climate where his particular complaint is rare. Thus it is customary for people attacked with pulmonary complaints to remove to localities where the air is pure and dry and sunshine abundant. So it is of advantage to the consumptive to exchange unwholesome city air for pure air in the country. Modern sanitation is learning to deal with conditions which, alike in populous and sparsely peopled places, have hitherto bred diseases; so that immunity from fatal disorders may be said to show the good results of sanitary science, as do also the improved statistics of longevity.

**ENDER, Eduard**, Austrian painter: b. Vienna 1824. He is the son of Johann Ender (q.v.) and is noted alike for his historical and genre works, among which are 'Francis I in the Studio of Cellini'; 'Shakespeare Reading "Macbeth" before the Court of Elizabeth'; 'La Corbeille de Mariage'; and 'A Game of Chess.'

**ENDER, Johann**, Austrian artist: b. Vienna, 4 Nov. 1793; d. 16 March 1854. As a portrait painter he was successful at an early age. In 1818-19 he made a tour of Italy, Turkey and Greece, remaining in Rome 1820-26. Upon his return to Venice he devoted his attention to miniature and historical paintings, being professor at the Academy from 1829 to 1850. Among his works are 'Madonna with Slumbering Christ-Child' (Vienna Museum); 'Marcus Aurelius on His Death Bed' (1814, Esterhazy Gallery); his masterpiece, 'The Crucifixion' (a fresco in the Vienna Cathedral); 'Orestes Pursued by the Furies' (1815); 'Minerva Showing Ithaca to Ulysses' (1816); 'Assumption'; 'Sleeping at Christ's Sepulchre' (1817); 'Judith'; 'Bacchus Finding Ariadne'; and many portraits.

**ENDER, Thomas**, Austrian artist: b. Vienna, 4 Nov. 1793; d. there, 28 Sept. 1875. He was twin brother of Johann Ender (q.v.). He also studied at the Vienna Academy, becoming a noted landscape painter. He won the grand prize at the Vienna Academy 1816. Going to Brazil in 1817, he brought back nearly a thou-

sand drawings and water colors. He visited Italy, Palestine, Greece and Paris. In 1836 he became corrector and later professor at the Vienna Academy, filling that chair until 1849. Among his works are 'View of Grossglockner'; 'Castle Tyrol'; 'Coast of Sorrento'; 'View of Rio de Janeiro' (Vienna Academy); 'Chapel in the Woods' (National Gallery, Berlin).

**ENDERBY LAND**, a region in lat. 65° 57' S., long. 47° 20' E., named by John Briscoe in 1831, when on a whaling voyage, in honor of his employer, Samuel Enderby. Briscoe could not approach within 20 or 30 miles, and was unable to say whether it was an island or a strip of continental coast. It was first discovered by Dirk Gherritoz, in 1599, and named for him.

**ENDERMIC**, a term designating a form of medication once much in vogue, but now almost abandoned, consisting in raising a blister upon the affected part and applying to the raw surface the remedy to be absorbed. It has been superseded by the hypodermic method. See **HYPODERMIC INJECTION**.

**ENDICOTT, Charles Moses** ("JUNIUS AMERICANUS"), American historical writer: b. Danvers, Mass., 1793; d. Northampton, Mass., 1863. He contributed to the 'New England Historical and Genealogical Register' and to the Boston *Gazette*. He wrote a 'Life of John Endicott'; 'The Persian Poet, a Tragedy'; 'Essays on the Rights and Duties of Nations'; and 'Three Orations.'

**ENDICOTT, John**, American colonial governor: b. Dorchester, England, 1589; d. Boston, Mass., 15 March 1665. He was sent out to this country by the "Massachusetts Company" to carry on the plantation at Naumkeag, or Salem, where he arrived 6 Sept. 1628. In April 1629 he was chosen governor of "London's plantation"; but in August it was determined to transfer the charter of the colony to New England, and Winthrop was appointed governor. Endicott was deputy-governor of the Massachusetts colony 1641-44, in 1650 and 1654; and was governor in 1644 and 1649, 1651-54 and 1655-65. He was bold and energetic, a sincere and zealous Puritan, rigid in his principles and severe in the execution of the laws against those who differed from the religion of the colony. So averse was he to everything like popery that he cut out the cross from the military standard. He was opposed to long hair, insisted that the women should wear veils in public assemblies and did all in his power to establish what he deemed a pure Church. In 1659, during his administration, four Quakers were put to death in Boston. Consult Endicott, C. M., 'Memoir of John Endicott' (Salem 1847).

**ENDICOTT, Mordecai Thomas**, American naval officer: b. May's Landing, N. J., 22 Nov. 1844. He was graduated at the Rensselaer Polytechnic Institute in 1868; practised as civil engineer from 1868 until appointed civil engineer in the United States navy in 1874. He served as consulting engineer at various navy yards and in the Navy Department at Washington. In 1895 he was appointed member of the Nicaragua Canal Commission, of the United States naval armor factory board in 1897 and in 1898 became chief of the Bureau of Yards and Docks with rank of commodore. Later he was advanced to the rank of rear-admiral, and reappointed in

1902 and 1906. In 1905 he became a member of the Isthmian Canal Commission, retired in 1906, but continued upon active duties until 30 June 1909. He is a member of the American Society of Civil Engineers and was its president in 1911.

**ENDICOTT, William Crowninshield**, American lawyer: b. Salem, Mass., 19 Nov. 1826; d. Boston, 6 May 1900; was a descendant of John Endicott (q.v.), the Puritan governor of Massachusetts. He was graduated at Harvard College in 1847; served as justice of the State Supreme Court (1873-82); was an unsuccessful candidate for governor of Massachusetts, on the Democratic ticket, in 1884; and was appointed Secretary of War in President Cleveland's Cabinet in 1885.

**ENDIVE**, ɛn'div (*Cichorium endivia*), an annual or biennial herb of the natural order *Compositæ*. It is an East-Indian annual or biennial, with a rosette of smooth radical leaves, more or less lobed or cut, blue axillary sessile flowers and grayish angular seeds. It has long been cultivated as a salad, for which use it probably ranks in Europe next to lettuce, but not quite so high in America. It is as easily cultivated as lettuce, but must be blanched, either by loosely tying the outer leaves up over the inner ones or by covering the plants with large drain-tiles or similar tubes. Of the numerous varieties, those that naturally are most curly-leaved, and that ordinarily develop a white centre without blanching, are the most esteemed. The leaves are also used as a pot-herb and as an ingredient in soups, stews, etc.

**ENDLESS or PERPETUAL SCREW**, a mechanical contrivance consisting of a screw the thread of which gears into a toothed wheel at an oblique angle corresponding to the pitch of the screw. It derives its name from the endless recurring effect its thread produces when in motion. It is in general use as a means of producing slow motion in the adjustment of machines rather than as a transmitter of great power.

**ENDLICH, Gustav Adolf**, American jurist: b. Alsace Township, Berks County, Pa., 29 Jan. 1856. He was educated in Germany and at Princeton; studying law and being admitted to the bar in 1877. He was elected judge of the 23d judicial district, Pennsylvania, 1879, and re-elected 1899. He was member of the United States Assay Commission in 1897, and from 1906 to 1910 was president of the board of trustees of Muhlenberg College. He edited the *Criminal Law Magazine and Reporter* 1890-94. He has published 'The Law of Building Associations' (1882); 'The Law of Affidavits of Defense in Pennsylvania' (1884); Woodward's Decisions' (1885); 'Commentaries on the Interpretation of Statutes' (1888); 'Rights and Liabilities of Married Women in Pennsylvania' (1889); and numerous articles on legal subjects for periodicals.

**ENDLICHER, ɛnd'lɪn-ɛr, Stephen Ladislas**, Hungarian botanist: b. Hungary, 24 June 1804; d. Vienna, 28 March 1849. He was destined for the priesthood, but in 1827 began botanical and linguistic studies. He became curator of the manuscript department of the Imperial Library at Vienna in 1828; and in 1836 of the botanical department of the Royal

Natural History Museum there, and in 1840 became professor of botany in Vienna and director of the Botanical Garden. Much disturbed by the events of 1848, he fell into melancholy, and in 1849 put an end to his own life. His 'Genera Plantarum' (1836-40) has had great influence on succeeding botanists. His studies in Oriental philology are also important. Among them may be mentioned 'Anfangsgründe der chinesischen Grammatik' (1845); and with Eichenfeld, 'Analecta Grammatica' (1837).

**ENDOCARDITIS**, inflammation of the endocardium or serous membrane lining the valves and internal surface of the heart.

**ENDOCERAS**, ɛn-dōs'e ras, genus of fossil cephalopods, found in the Ordovician rocks of the United States, Russia and Scandinavia. Many species have been uncovered; the conch is long, slender and either annulated or smooth. Specimens have been found in the Trenton rocks of New York, having a length of over 10 feet. See CEPHALOPODA.

**ENDOCHROME**, the characteristic pigment mixture of diatoms. It is apparently a mixture of a green constituent and a golden-brown constituent (diatomin). See DIATOMACEOUS EARTH.

**ENDOCRINOPATHIES**. Diseases or disorders of growth or adjustment due to disturbances of the endocrinous glands, or glands of internal secretion. The early mechanistic conceptions concerning the push that lies behind the metabolism of the human body have slowly and gradually undergone modification until the importance of a number of overlooked structures has forced itself, almost with a whirl, upon the medical horizon. These structures are the endocrinous glands. The study of their anatomy and functional importance now constitutes an enormous specialty.

As early as 1828 Parry called attention to the relationship between enlarged thyroid and increased frequency of the heart beat (tachycardia), since which time the works of Johannes Müller, Addison, Gull, Brown-Séquard, Marie and many others have served as starting points for the building up of a rich structure which is amply recorded in a score of monographs. The chief of these are Biedl, 'Internal Secretions' (bibliography of 4,000 titles, 1913); Falta, 'Ductless Glands' (1915); Parhon et Golstein, 'Les Sécrétions Internes' (1909); Levy and Rothschild, 'Endocrinologie' (1913); Gley, 'Les Sécrétions Internes' (1914); Sajous, 'Internal Secretions'; special articles in Lewandowsky's 'Handbuch der Neurologie' (1913), and Jelliffe and White, 'Diseases of the Nervous System' (2d ed., 1917).

Out of this prodigious development to be found in the works just cited and in current medical literature, much of which is evanescent and hastily constructed, a large amount of solid substance remains and a number of permanent acquisitions have been made. The net result has been to show much more essentially than ever before the fundamental physicochemical foundations of biological metabolic processes as they are utilized in the upkeep of the animal machine. The viewpoint has been attained that a marked degree of chemical interrelationship takes place between the different organs of the body. That this is automatically regulated

through the vegetative nervous system (the old sympathetic) chiefly, apparently in some cases, though this is by no means clear, solely through chemical regulation. The disorders of this adjustment now constitute a special department of vegetative neurology, and are most conveniently grouped under the terms endocrinology, or the endocrinopathies.

In the earlier period of the study of these endocrinopathies individual disease groups, uniglandular syndromes, were isolated. Among the most accentuated of these were Addison's disease, diabetes mellitus, myxedema, cretinism and acromegaly; but of recent years it has been increasingly emphasized that whereas a certain group of symptoms, which may be linked to plus or minus activities of one or another gland may be most prominent, nevertheless other glandular modifications are bound up in them and are not to be neglected. Hence has arisen the viewpoint that most of the endocrinopathies are, strictly speaking, poly- or pluriglandular syndromes, that is, that disease or maladjustment in one gland usually induces compensatory changes in other glands.

For many years, even back to the earliest days of primitive animistic magic, it has been held that every living tissue yields a chemical product which will act upon other tissues. The early alchemistic studies, those of Paracelsus, to the later work of Hahnemann, and the isotherapists, are all attempts to co-ordinate a host of empirically observed facts. They are all worth rereading if the reader will put himself in sympathy with them through a comprehension of the now strange symbols then used.

Endocrinous glands for the present purposes are those structures which yield products termed hormones and chalone having some definite or specific action related to, yet different from, enzyme activities. These structures are developed from different embryological formations. The hypophysis (posterior lobe) and chromaffin tissues (suprarenal chiefly) are nervous; the thyroid and pituitary (anterior lobe) come from the buccal cavity; the pancreas and mucosa of the small intestine from the intestine, the parathyroids and thymus from the branchial arches (old gill slits of fishes); the gonads (testes and ovary) and the interrenal bodies from the genital ridges. Some of these, in humans, merge into one structure, as thyroid and parathyroid, as chromaffin and interrenal cells in the suprarenals, as hypophysis (posterior lobe) and pituitary (anterior lobe).

The present résumé, largely following the author's summary in Stedman's 'Reference Handbook of the Medical Sciences,' will attempt to sketch only the general outlines of the various uniglandular and pluriglandular disease pictures. The more radical French school is followed, but at the same time attention should be called to the fact that the French school presentations contain gross fallacies, and should be read *cum grano salis*. Still the clinical suggestions of these writers are so rich it is felt to be a better course to call the attention of the intelligent layman to possible relationships rather than to take the more conservative attitude of directing attention only to that which can indubitably be proved. This whole subject is still so largely empirical that the principle of putting the hypotheses to a test will be found to be more advantageous than that of

recording only the obvious. The former attitude may result in gaining useful therapeutic truths, the latter becomes monotonous and frequently encourages stupidity.

The more recent suggestive and extreme summaries of Biedl, Falta, Laignel-Lavastine, Levi and Rothschild are therefore here summarized.

**Uniglandular Syndromes. Thyroid.**—Myxedema.—The chief symptoms are arrest of development, dwarfism, infantilism, infiltration of skin and mucous membranes, mental torpor, slow ideation, defective memory, apathy, laziness, slowness, sleepiness, taciturn, awkwardness. The pulse is usually small, rapid and irregular, at times increased tension. There are constipation, diminished urination, hypothermia and chilliness of the skin. Reflexes diminished. The voice is frequently nasal, slow, monotonous and raucous. Headache is frequent and at times epileptic attacks occur. These are all symptoms of diminished secretion.

**Exophthalmic Goiter.**—A more or less complete catalogue of findings for a lot of cases will include tachycardia, arrhythmia, anxiety, pulsations in the neck, exophthalmos, epiphora, v. Graef's, Stellwag's, Möbius' symptoms, facial paresis, cramps, tremors, neuralgias, chiefly frontal and ocular, colic, hot flashes, profuse sweats, thermophobia, engorgement of the skin, dermatographism, transitory edemas, pigmentation, urticaria, alopecia, diminution of electrical resistance, albuminuria, polyuria or glycosuria, anorexia, bulimia, vomiting, ptyalism, hyperchlorhydria, diarrhoea, dyspnoea, amenorrhoea, atrophy of mammae, loss of flesh, agitation, emotional instability, volubility, insomnia, anxiety, excessive anger or reverse, maniacal excitement, marked depression, cyclothymic variations, confusion, epileptic attacks. Ep-pinger and Hess have endeavored to separate a vagotonic and sympathicotonic type.

In the vagotonic type the more prominent signs are decreased lacrymation, less exophthalmos, with enlargement of the palpebral fissures, v. Graef's sign, abundant sweating, diarrhoea, mild tachycardia, no alimentary glycosuria, pilocarpine and oculocardiac reflexes positive. In the sympathicotonic types there are exophthalmos, dryness of eyes, violent tachycardia, glycosuria, oculocardiac reflex reversed or absent, increased reaction to adrenalin. Most cases are mixed in type. In all save infectious forms psychological influences are striking and psychotherapy is extremely valuable in the early stages, less so in chronic cases. Money worries are of great importance in the causation of the psychogenic cases.

Thyroid insufficiencies, other than those of myxedema, are infantilism, obesity, Dercum's syndromes, pseudolipomata, alopecia, precocious loss of hair, scleroderma, urticaria, pruritus, recurring herpes, transitory edemas, migraine, asthma, constipation, mucous enterocolitis, acrocyanosis, Raynaud's syndrome, localized erythemas, rhinorrhoea, glucose tolerance, genital instability, chilliness, mammary hypertrophy.

**Thyroid Instability (Levi and Rothschild).**—From dyshypothyroidism: chilliness, baldness, headaches, depression, crying, giddiness, passing edemas, neuralgic pains, suffocations, shivering hot flushes, at menstrual period. With predominant dyshyperthyroidism: thinness, in-

crease of eyebrow development, hot flashes, palpitation, intestinal spasms, irritability, emotionalism, phobias, inquietudes, migraine, asthma, hyperidrosis, dysidrosis, tremors. Mixed cases: chilliness, shivering, migraine, frequent urination, neuralgic pains, distractable reddening of eyebrows, catamenia; neuralgias, anxiety, dilatation of palpebral fissures, swelling of feet, variations in volume of the feet, tremors, nervous crises, hysterical attacks.

*Parathyroids.*—Tetany.—This syndrome is unquestionably related to parathyroid loss or deficient Parkinson's syndrome(?). The viewpoint of Lundborg and of Gauthier is that this syndrome belongs here, and is a hyperfunction disorder but it rests on very unstable foundations.

*Thymus.*—Vagotonic Symptoms of Basedow Syndrome(?): Profuse sweating, palpitation, lymphocytosis, eosinophilia, sensation of weakness.

Myasthenia of Erb-Goldflam(?): Headache, ptosis, external ophthalmoplegia, fixed or transitory palsies principally of the face, the neck, myasthenic electrical reaction.

Thymus Loss: Idiocy of Klose and Vogt.

Tetany(?): Basch.

*Suprarenals.*—Addison's Syndrome and Suprarenal Insufficiency: Asthenia, arterial hypotension, morning nausea and vomiting, lumbar pains, melanoderma, white lines on the skin, amyotrophy, aboulia, depression. At times myoclonus, epileptic attacks, tetany, periodic palsies, delirium, mental confusion, sudden death.

Suprarenal-genital Syndrome: External feminine pseudo-hermaphroditism with virile secondary sexual characters; suprarenal virilism; amenorrhœa, gynecomasty, adiposis with easy bruising, all signs of feminine maturity; hypertrophy of the clitoris, hypertrichosis of masculine type, masculine voice, muscular and nervous hyperasthenia, active and violent sexual inversion; arterial hypertension, arteriosclerosis; glycosuria.

*Sympathetic Paraganalia.*—Chromaffine cells of the solar plexus, aortic paraganglion of Zuckerkandl, cardiac paraganglion of Wiesel and Weisner, Luschka's carotid and coccygeal glands, tympanic paraganglia. The syndrome of the affections of these glands is entirely obscure.

*Pancreas.*—Diabetes Mellitus: Glycosuria, polyuria, polyphagia, polydipsia; neuralgias, pruritus, impotency, constipation, dry mouth, dry skin, diminished perspiration, atrophy of the testicles, abolition of the tendon reflexes, arterial hypertension, asthenia, headache, susceptibility to cold, perforating ulcer of the foot, syncopies, comatose or apoplectiform attacks, paralyses, vertigos, asthmatic dyspnœas, pseudoangina, narcolepsy, depression, apathy, hypochondria and coma.

*Hypophysis.*—Froehlich's Genital Adiposity Syndrome: Adiposity, arrest of development or regression of the genital glands of the genital organs and the corresponding secondary sexual characters; somnolence.

Syndrome of Hypophyseal Insufficiency of Rénon and Delille: Tachycardia, instability of the pulse, arterial hypotension, insomnia, anorexia, distressing sensation of heat, exaggeration of sweat secretion.

Acromegaly: "A simple hypertrophy, not

congenital, of the upper and lower extremities and also cephalic," headache, amenorrhœa, tendon reflexes increased, arrhythmia, syncope, perspiration, polyuria, glycosuria, sensitiveness to cold, neuralgias, acroparesthesia, cramps, lancinating pains, lassitude, irritability, depression.

Gigantism: "Acromegaly of the subjects in the epiphyseal cartilages which have not yet ossified," impotency, amenorrhœa, indolence, infantilism, aboulia, asthenia, glycosuria, polyuria.

*Pineal.*—Genital Macrosomia: Abnormal increase in height, premature genital and sexual development with secondary sexual characters, hypertrichosis, exaggerated mental precocity.

Pineal Adiposity: Diffuse obesity.

*Choroid Plexus.*—Hydrocephalus: Hypertension of the cerebrospinal fluid, rapid development, nervous and mental syndrome of ventricular hypertension, obtundation, idiocy.

*Ovaries.*—Infantilism: Amenorrhœa, absence of secondary feminine characters, obesity, deficiency of hair, childishness.

Acquired ovarian insufficiency. (a) Peripheral vasodilatation, subjective crises of heat, sweating, continuous or paroxysmal tachycardia, palpitations, arterial hypertension, insomnia, severe headache, facial neuralgia, lumbago, neuromuscular asthenia, memory instability, irritability, enervation, hysterical crises; exaggeration of the sexual instinct(?), more often absent or inverted; obesity, restlessness, anxiety, phobias, impulsions, gastrospasm, constipation, vomiting, vertigo, syncope.

(b) "Vagotonic crises" before the menses and at the beginning of pregnancy, pallor, tendency to syncope, nausea, vomiting, constipation, diminished arterial tension, pulse rather slow, oculocardiac reflex positive, Samogyus's sign, psychic depression particularly connected with the development of the corpus luteum. These crises occurring before menstruation or at the beginning of pregnancy must not be confused with the reactionary dyshyperthyroidism of the menopause marked by flashes of heat, sweating, hypertension, paroxysmal tachycardia, palpitations, anxiety.

"Hyperovaria" (Dalché): Precocious puberty, covariis menstruation, pain before and during the first days of the period, intermenstrual leucorrhœa, developed sexual instinct, well-marked eyebrows, thinness, pallor, small breasts, large pelvis, rounded lower limbs contrasted in size with the upper ones, arterial hypotension, craving for movement and action, enervation, tendency to loquacity, erotic crises.

*Testicles.*—Infantilism: Defective development of the male genital organs, absence of secondary sexual characters, obesity, deficiency of hair length of the lower limbs, small cranium, childishness.

Acquired Testicular Insufficiency: Increase in height, diminution of the pilous system, glabrous state of the body, tendency to obesity, gynecomasty, frigidity, impotency, senility, arterial hypertension(?), asthenia.

The types of testicular insufficiency according to Rebattus and Gravier are: (a) The sterile. (b) Eunuchoid gigantism, because the internal secretion of the testicle is established late. In this case there is a prolonged infantilism. (c) Eunuchism by castration character-

ized by gigantism and infantile appearance. The secondary sexual characters do not appear. (d) The reversive infantilism of Gandy, where simply a sort of a sexual condition is noticed, with attenuation of secondary sexual characters and a certain degree of obesity, with late testicular difficulty in the adult.

**Dyshyperdiastemata:** Lower limbs short and cranium very large, pilous system well developed, especially the mustache, thinness, persistence of youth, a degree of arterial hypertension, virile character, activity, moral and physical energy.

**Prostate.**—Prostatic Insufficiency: Asthenia, diminution of potency, neurasthenia, at times suicide.

**Hypertrophy of Prostate:** Arterial hypertension, retardation of the heart, cerebral hemorrhages, genital excitation.

**Pluriglandular Syndromes.**—Basedow's disease with thymic hypertrophy and vagotonic symptoms; scleroderma, and tetany, amenorrhœa, Addison's syndrome; acromegaly, etc.

**Myxedematous with Thymic Hypertrophy:** Tetany, acromegaly, Addison's syndrome, amenorrhœa, infantilism, mammary hypertrophy, etc.

**Acromegalic or ovarian insufficiencies** with various disturbances, psychic, nervous, vasomotor, trophic, etc., connected at one time with the myxedematous, at another with the basedowian series.

**Ovarian Predominance.**—Thyroid Reaction to Ovarian Insufficiency: Tachycardia, palpitations, perspiration, nervous irritability, vertigo, scanty urination, trembling, anxiety, etc.

The differences between these nervous manifestations and the picture of the attenuated forms of exophthalmic goitre are very slight says Laignel-Lavastine. This pathogenic conception permits of important therapeutic results; one may ask, for example, whether the anti-basedowian therapy with hematothyroidin would not be of advantage in the nervous and psychic disturbances of the normal menopause which repeat one feature after another of the basedowian series.

**Dyshyperovaria of the Hypothyroid:** Anticipation, prolongation and copiousness of the menses, menorrhagia, metrorrhagia.

**Thyro-ovarian Disturbances of the Same Significance.**—Either ovarian insufficiency in the myxedematous series, or the dyshyperovarian in the basedowian series; in either case the nervous disturbances of the dysthyroid are modified by all factors of the ovarian rhythm, whatever they may be.

**Hypophyseal Predominance.**—Infantile giants, with their clinical varieties: feminism, eunuchism cryptorchidism, feminine pseudohermaphroditism, mental infantilism.

**Acromegalics with deficiency syndromes,** myxedema, infantilism, amenorrhœa, obesity, asthenia.

**Acromegalics with syndromes of hyperactivity,** more or less vicious, synergetic or substitutive: simple or exophthalmic goitre, arterial hypertension and atheroma, lacteal secretion.

**Suprarenal Predominance.**—Addisonian with amenorrhœa, impotence, chilliness, tetany or, on the other hand, exophthalmic goitre.

Very often basedowians, acromegalics, giants, with spontaneous glycosuria, alimentary or merely adrenal, the latter making it possible in

certain cases to suppose a certain degree of suprarenal hyperactivity.

**Without Marked Predominance.**—The case of Claude and Gougerot is an example: Loss of sexual characters, countenance old-looking, skin thickened, wrinkled, pigmented; chilliness, absence of perspiration, asthenia, arterial hypotension, tetany; testicular, prostatic, suprarenal, thyroidal and perhaps parathyroidal atrophy. Consult Jelliffe and White, 'Diseases of the Nervous System' (Chap. III, "The Endocrinopathies"); Eppinger and Hess, 'Vagotonia, Nervous and Mental Disease' (Monograph Series, No. 20, New York).

SMITH ELY JELLIFFE.

**ENDODERM, or ENODERM** (also called entoblast or hypoblast), the innermost layer of cells in the developing embryo. In man it subsequently develops into the epithelium that lines the digestive canal and its appendages, the pancreas, liver, lungs, etc. See EMBRYOLOGY.

**ENDODERMIS**, in plants, the layer of cortical cells which surrounds the vascular region and generally called the bundle sheath. In many cases there is but a single sheath surrounding a single vascular region; in others there are several vascular regions each protected by its own sheath or endodermis. See MORPHOLOGY.

**ENDOGAMY**, a custom among some savage peoples of marrying only within their own tribe. Opposed to exogamy.

**ENDOGENS**, ěn'dô-jěnz, a name for monocotyledonous plants, referring to the mode of growth of the stem. See BOTANY; MONOCOTYLEDONS.

**ENDOR**, ěn'děr, a village of Palestine, four miles south of Tabor, now a poor mud hamlet. It was the place which Saul visited (1 Sam. xxviii, 7) to consult the "woman with a familiar spirit." The word is in common use in the writings of the Philistines.

**ENDORSE**, in heraldry, a subordinary equivalent to one-eighth or one-fourth of a pale.

**ENDOSCOPE**, in surgery, a general term for an instrument for the examination of internal parts. It consists of a tube and an apparatus for lighting. The most serviceable is that devised by Nitze and Leiter.

**ENDOSMOSIS.** See OSMOSIS.

**ENDOTHELIOMA**, ěn-dô-thě-lĭ-ô'ma. See TUMOR.

**ENDOTHELIUM**, a modified form of the cells lining certain internal organs. Such are the internal lining membranes of the heart and blood vessels, the joints and other closed cavities. Endothelium is a modification of epithelium (q.v.).

**ENDOTHYRA**, genus of fossil. Foraminifera, the shells of one species of which (*E. baileyi*) form a large part of the oölitic limestone of the Lower Carboniferous and known as Bedford limestone. See FORAMINIFERA.

**ENDOWED SCHOOL ACTS.** Acts of the British Parliament made to prevent misapplication of the foundations for the support of secondary education in England. See GREAT BRITAIN — Education, and consult Balfour, A.

J., 'The Educational Systems of Great Britain and Ireland' (Oxford 1912).

**ENDROMIS** (1) a kind of boot which was first generally worn by Cretan huntsmen and then by athletes in general. It was close-fitting, reached above the ankle, with the top turned down. (2) a woolen rug or covering worn by Roman athletes, gladiators, etc., after violent exercise. They were made in Spain or in Tyre.

**ENDYMION**, in classical mythology, according to some a huntsman; according to others a shepherd; and according to a third account a king of Elis. One tradition is that he asked of Zeus eternal youth and eternal sleep, and that Selene (the moon) saw him sleeping and became enamored of him. Others relate that Selene herself, charmed by his beauty, conveyed him to Mount Letmus in Caria and threw him into a perpetual sleep in order that she might kiss him whenever she pleased. The legend is the subject of Keats' 'Endymion.'

**ENDYMION**. Keats was 23 when, in April 1818, he published his first long poem, 'Endymion.' The young poet, in love no less with the beauty of his native England than with "the beautiful mythology of Greece," incarnated in the poem his own passionate seeking for the soul of beauty in the world. We may trace this theme through the "uncertain path" of a story which is almost lost in the luxuriant tangles and by-paths of incident and description. Endymion, smitten with strange trance at the feast of Pan, confesses to his sister the vision of an immortal loved one that has turned waking life to despair. Led on to "woe-worn wanderings" by a mysterious command, he descends "into the silent mysteries of earth." He is succored by Diana, urged on by Venus, who foretells his happiness, and is moved to pity by the vain loves of Alpheus and Arethusa. And when at length his "fated way" leads him through the sea-depths to the rescue of spell-bound Glaucus, Endymion's awakened sympathy with suffering gives him power not only to restore "all lovers tempest-tost" to eternal love and youth, but to win Cynthia and immortal bliss. So at last his mortal love, the Indian damsel, reveals herself as the goddess; and through earthly loveliness he attains immortal beauty. And so this story of Endymion's love for the moon-goddess is the symbol not only of Keats' intense susceptibility to the loveliness of moonlight but of his life-long passion for "the principle of beauty in all things."

The form of the poem is, like its spirit, wavering, but shot through with imaginative glory. Structure is lacking—the poet does not master his story, but is swept on by it, like Endymion on his celestial steed. Metre and diction are treated with a freedom not only Elizabethan but revolutionary. And in such lyric ecstasies as the "Hymn to Pan" and "O Sorrow," in such perfect images as "the dancing poppies," "tip-toe Night," "panting light," "rain-scented eglantine," there speaks Keats, the magician of English poetry. Consult article "Keats," 'Cambridge History of English Literature' (Vol. XII); and Colvin, Sidney, 'John Keats' (New York 1917).

FRANCES W. CUTLER.

**ENEMATA**, fluid substances passed into the rectum and large intestines for cleansing, for medication or for nutrient purposes. For the treatment of chronic constipation, enemata of cold or hot water, water and soapsuds, water and glycerine, are found to be of great service. Almost any remedial substance capable of solution and absorption may be placed in the rectum or large intestine to affect the parts locally or to exert a general action on the body. Almost all remedies that are taken into the stomach may be taken by means of enemata. The dose has to be somewhat larger in most instances. For the treatment of pinworms, diarrhœa and dysentery enemata are invaluable. In medicine the lower bowel may be used much oftener than it is. In acute colicky pains from "wind" in the bowels there is nothing better, as a rule, than a hot enema of at least two quarts, at a temperature of from 116° to 118° F. As the lower bowel is not provided with digestive juices, when nutrient enemata are to be given the insoluble food-substances should be so converted as to render them capable of absorption—hence all gruels, eggs, milk, etc., to be used should first be predigested by peptic or pancreatic ferments. A special form of enema, consisting of hot (116° to 118° F.) salt solution (1 teaspoonful of salt to 1 pint of water), allowed to pass in and out of the bowel slowly and made to ascend some distance, is of immense service in cases of surgical shock, in profuse bleeding, and in cases in which the kidneys refuse to secrete urine. This is termed enteroclysis (q.v.). Enemas for cleansing the bowel should be copious; those for nutrient purposes should be small—not over half an ounce.

**ENEMY**, in international law, a nation at war with another. The term includes the nation as a whole, and also individuals belonging to the latter. A state of war must exist before States assume toward each other the position of enemies. By international law the status of an enemy is regulated according as it is a combatant or non-combatant. If a combatant the opposing nation may employ its whole force toward its destruction. Non-combatants, however, in as much as they have no connection with the war but continue their ordinary avocation, are exempt from attack according to the usage of modern civilized peoples. A state of war precludes commercial relations between the non-combatants of states at war, contracts are not upheld, and the courts are closed to enemy aliens. Ordinarily non-combatants are not liable to injury in person or property arising from military operations, but it frequently happens that they suffer property losses through bombardments, etc. If attacked or robbed by troops of the enemy without authorization and contrary to international law those troops are liable to punishment by their own military superiors for violation of the rules of war. The modern tendency of civilized peoples is to limit all acts of hostility to the actual combatants in the theatre of war.

It has frequently happened, however, that modern nations while engaged in hostilities with savage peoples have been unable to observe all the rules of international law, and especially the distinction between combatants and non-combatants. See ALIEN; BELLIGERENT; INTERNA-

TIONAL LAW; WAR, RULES OF, and consult the authorities referred to under these articles.

**ENEMY ALIEN PROBLEMS.** In early times it was the practice of belligerent governments upon the outbreak of war to arrest the citizens or subjects of the enemy power residing within their jurisdiction, to confiscate their property and sometimes to expel them summarily from the country. In the course of time, however, relaxations from this harsh practice began to be made and many treaties were concluded providing that such persons should either be allowed to remain in the country, or in case they were required to leave, they should be allowed a specified period within which to dispose of their property and wind up their business affairs. The policy of confiscating their property also ceased and wholesale expulsions became rare. During most of the wars of the 19th century the treatment accorded to enemy aliens was uniformly liberal and humane. During the Spanish-American War of 1898, for example, neither belligerent molested the citizens or subjects of the other, so long as they demeaned themselves peaceably and their property was not interfered with in the slightest degree. When the present European War broke out the rights of enemy aliens had not been regulated by any of the great international conventions; the treatment to which they were entitled, therefore, depended upon the customary law of nations and upon particular treaty stipulations between the opposing belligerents.

The enemy alien problem of the present war has been somewhat different from that of any preceding war, partly because of the unprecedented number of enemy aliens which were found in most of the belligerent states at the outbreak of the conflict, and partly because of the enormous amount of property held by such persons in the countries where they resided. In England, for example, there were more than 50,000 German subjects; in France the number was still larger; and in the United States the number of such persons probably exceeded a million. In consequence of the German policy of universal compulsory military service large numbers of them were reservists who if they had been allowed to depart would have returned to Germany and joined the army. Many of them were of course spies, for the German historian Treitschke tells us that "in the national wars of the present day every honest subject is a spy." The presence of such persons in so large a number in England and France, because of the close geographical proximity of those countries to Germany naturally constituted a grave danger to both countries. It was impossible in view of these circumstances to allow males of military age to leave the country and it was equally impossible to leave them to remain in complete freedom.

The treatment which was accorded to every alien by the various belligerent governments may be discussed under three heads: (1) policy in respect to their personal freedom; (2) measures in respect to their property and business undertakings; and (3) their right of access to the courts. At the outset Great Britain accorded to German subjects a period of seven days during which they might leave, but it does not appear that any considerable number suc-

ceeded in getting away. France allowed them to leave before the end of the first day of mobilization, but few were able to return to their home countries. Germany and the United States did not allow any days of grace for this purpose and Germany even went to the length of arresting all Japanese subjects found in the country at the outbreak of the war between that country and Japan. British and French nationals were summarily expelled from any German towns and cities and without being allowed to take their effects with them. On the day of the outbreak of war between France and Germany the French government as a military precaution required all enemy subjects to evacuate the region of the northwest, and also the cities of Paris and Lyons and to retire to other regions in the west. They were not, however, expelled. Portugal appears to have been the only belligerent country which went to the length of expelling all enemy persons between certain ages. In every belligerent country measures were early taken to restrict the liberty of movement of enemy aliens. In England they were required to reside in certain "approved" places; they were forbidden to reside in certain designated regions or to change their places of residence or travel more than five miles without a permit; they were forbidden to have within their possession any firearms and various other articles such as signaling apparatus, military maps, motor cars, etc.; they were forbidden to frequent clubs; to see any but English newspapers, etc. In every belligerent country they were required to register and were placed under strict surveillance by the authorities. In the United States they were forbidden to reside within a certain distance of any fort, arsenal, armory or similar place; they were excluded from residing near to or from approaching water fronts or wharves, and they were prohibited from remaining or residing within the District of Columbia. All enemy aliens including women were required to register, and in general they were subjected to other restrictions similar to those adopted by the British government. On account of the close geographical proximity of France to Germany, the French government at the outset ordered a general internment of the enemy population. They were therefore removed to concentration camps located in various parts of France, mainly in the west, behind a line extending roughly from Dunkirk to Nice. For some eight months after the outbreak of the war the British government did not go to such lengths, although considerable numbers of suspicious and dangerous characters were interned as a precautionary measure. In consequence, however, of various acts of the Germans, such as the bombardment of undefended coast towns, Zeppelin raids upon England, the use of asphyxiating gases as a means of combat, the ill-treatment of English prisoners, and the like, public opinion in England came to demand that the whole enemy population of England should be interned, and the sinking of the *Lusitania* in May 1915 greatly intensified the popular demand. This last act led to serious mob outbreaks against the Germans in England and the dominions, during the course of which many German houses and shops were wrecked and a considerable number of lives were lost. Partly,

therefore, in the interest of the national defense and partly in the interest of the Germans themselves, whom it was difficult for the public authorities to protect so long as they were scattered throughout the United Kingdom, the British government in May 1915 ordered the internment in concentration camps of practically all enemy persons then left in England, although exemptions were granted in particular cases where internment would have worked a serious hardship without subserving any purpose of national defense. The order for internment, it may be added, applied not only to enemy subjects but also to British subjects (of which there were some 8,000), of enemy origin. So far as possible work was provided in the camps for such persons; classes for instruction were organized, libraries were established, and instructors in the handicrafts were furnished. Long before the British policy of internment had been decided upon, the German government, in consequence of reports that large numbers of Germans were being arbitrarily arrested and imprisoned in England, had issued an order (6 Nov. 1914) for the general internment of all British males between the ages of 17 and 55. Most of them were interned in the buildings of a race course at Ruhleben near Berlin. The United States was almost the only great power which did not resort to the policy of general internment, for there the presence of enemy aliens at large did not, by reason of the remoteness of the country from Germany, constitute the same danger as it did in England and France. Large numbers of individual Germans whose disloyalty was clearly established, others who were regarded as suspects or dangerous persons, and still others charged with espionage and other crimes were, however, arrested and confined in internment camps in various parts of the country. The members of the crews of German merchant vessels in American ports as well as the crews of German warships which took refuge in American ports were likewise interned. Other enemy persons who conformed to the regulations in regard to residence, movement and registration and who demeaned themselves peaceably were left at large, although they were subjected to close surveillance and were frequently warned against the consequences of misbehavior and disloyalty.

Subsequent to the inauguration of the policy of wholesale internment, special conventions were concluded between a number of the belligerent governments providing for the reciprocal exchange and release of women and males except those of military age. Thus in January 1917 an arrangement was concluded between the British and German governments under which all males over 45 years of age and under 17 held in either country as interned prisoners were released and allowed to return to their own countries. In pursuance of this arrangement some 7,000 Germans in England and some 600 or 700 British subjects in Germany were repatriated. Somewhat similar arrangements were concluded between the German and French governments and between the German and Austro-Hungarian governments.

The presence in many of the belligerent countries of enormous property holdings and business houses owned wholly or in part by, or under the control of, enemy persons raised

a difficult problem for belligerent governments. Obviously considerations affecting the national defense made it necessary to deprive the enemy of the use and control of such property or business; otherwise his power would have been employed to increase its own strength and resources. Steps were therefore taken in every belligerent country for placing enemy-owned property and enemy business undertakings under the control or supervision of the public authorities. In England and the United States all such property was placed in the hands of a public custodian who was empowered to hold and administer it and in general to exercise over it all the powers of a common-law trustee throughout the period of the war. At first the American custodian was given only a limited right to dispose of such property by sale, as for example, when it was necessary to prevent waste or protect the rights of the United States therein, but later he was given a general power of sale and enormous German holdings aggregating many millions of dollars worth of property were sold. The proceeds were turned into the treasury of the United States and it is understood that the eventual disposition of it will be determined by the treaty of peace at the close of the war. The proceeds in some cases were used to purchase war bonds. It should be remarked, however, that this somewhat rigorous policy was not enforced against the property owned by enemy persons residing or domiciled in the United States, but only against property of those living in the enemy country and who were presumably engaged in making war upon the United States. The property holdings of the former, except those interned, have not been molested. The property of American citizens residing in Germany, however, was treated as enemy property on the theory that the test of enemy character is domicile rather than nationality.

In France enemy property was put under the control of sequestrators appointed by the courts and their power over such property was substantially the same as that of the English and American custodians, except that they were never given a general power of sale. Again and again it was emphasized in France that sequestrators were mainly conservators with no general power to dispose of the property placed in their custody. They were authorized to sell enemy property only when it was perishable or when it was necessary to protect it from waste or loss. Germany began by placing enemy property under supervision, but later on adopted the policy of other countries and put it in the hands of administrators who had the power to manage it and in some cases to dispose of it by sale. There was widespread complaint in France of the conduct of the German government in respect to its treatment of French property, especially in Alsace-Lorraine where large quantities were held and the proceeds of which in some cases were employed for the purchase of war bonds. As regards enemy business enterprises and undertakings, all belligerents adopted a somewhat similar policy. In England an official known as the controller was appointed to manage and carry on any enemy business undertakings the continuance of which was demanded by



the public interest. Other businesses were prohibited or wound up and liquidated by the Board of Trade. In the United States this power was exercised by the alien enemy custodian. Certain enemy businesses such as insurance were prohibited; in the case of other businesses under the ownership or control of enemy persons residing in Germany the boards of directors were reorganized by the appointment of new directors by the custodian, and the business was continued by the reorganized directorate. In Germany all enemy business enterprises were put under a régime of compulsory administration and management through government appointed agents. Some of them were continued; many were wound up and liquidated. Likewise, in France administrators were appointed by the courts to operate and manage any enemy enterprise, the carrying on of which was required by the public interest; others were wound up by a liquidator, likewise appointed by the courts. In the case of that particular species of property in the form of patents, trademarks, copyrights, etc., the policy of all belligerent governments was more liberal than it was in respect to other property. In general, the policy of all of them was to suspend such rights but without confiscating them. Citizens who held patents in enemy countries were allowed to transmit money thereto in order to pay the necessary fees for the renewal of their patents or copyrights. In most of the belligerent countries enemy patents for the manufacture and sale of articles which the public interest required to be manufactured were assigned to local firms or persons, the licensees in such cases being required to pay the fees and royalties due the enemy patentee into the public treasury the same to be held for the benefit of the enemy patentee until the end of the war or to be otherwise disposed of as might then be determined, presumably by the treaty of peace.

As to the right of enemy subjects to enforce their rights by suits in the courts or to appear in court and defend actions brought against them the policy of most of the belligerent governments has been fairly liberal. Under the English common law no enemy alien was allowed such a right unless he remained in England by permission of the Crown and was under the special protection of the king. During the present war, however, the English courts have not only held that an enemy alien residing in England may defend an action brought against him in the courts but that an enemy subject who is interned may bring an action as a plaintiff. Since practically the entire enemy population has been interned the effect of the decision is to open the courts generally to all enemy aliens in the country. This privilege, however, does not extend to persons residing or domiciled in enemy territory. Germany allowed enemy aliens domiciled in the empire the right of access to German courts but denied it to those residing or domiciled outside the empire. In France some of the lower courts admitted enemy aliens to bring actions but others less liberal refused it. The Court of Appeals of Paris in April 1916, however, rendered a notable decision upholding this right. In the United States the policy of the courts has been somewhat divided but in general enemy aliens re-

siding here have been allowed access to the courts on a footing of equality with citizens. Those residing in enemy country, however, are not allowed the privilege.

**Bibliography.**—Hall, 'International Law' (Pt. III, ch. 1); Lawrence, 'Principles of International Law,' (Pt. III, ch. 3); Oppenheim, 'International Law' (Vol. II, Pt. II, ch. 2); Phillipson, 'International Law and the Great War' (Ch. 5); Baty and Morgan, 'War, Its Conduct and Legal Results' (Pt. I, chs. 1-3); Garner (in *American Journal of International Law*, Jan. and July 1918).

JAMES W. GARNER,  
*Professor of Political Science, University of Illinois.*

**ENERGETICS.** In physics, mechanics and chemistry, Energetics is the science that treats of energy and its transformations—"energy" being defined as that attribute of a body, or of a material system, by virtue of which the body or system can do mechanical work; and "work" being simultaneously defined as the overcoming of resistance through distance. Any such body or system, that can do mechanical work by changing its shape, position or configuration, or its physical or chemical state, is said to possess "energy"—that is, power to do work.

The mechanical work is often performed directly and immediately by the body possessing the energy, without the intervention of any other agency. This is by no means essential, however, because the conception of energy has been extended so as to include all systems and processes, however complicated or indirect the development of the work may be. Thus a hot body is said to possess energy, because its heat can be used to actuate a heat engine; and a galvanic battery is similarly said to possess energy, because it can generate electricity and thereby operate an electric motor. We even speak of food as possessing energy, because when eaten, digested, assimilated and oxidized in the muscles it enables human beings or animals to perform mechanical work.

In view of the varied kinds of bodies and systems that exist, and the varied ways in which they may perform work, we speak of "heat energy," "electrical energy," "chemical energy" and energy of other types; but in using such expressions we merely indicate, in a rough way, the kind of source that we are dealing with and the general nature of the processes to which we may have to resort, if we attempt to utilize the energy. The energy is the same thing in every case—namely, it is the capacity of the body or system under consideration to do mechanical work. In many cases, in fact, it is hard to say in what condition the energy exists in a body. For example, a mass of hot, compressed gas certainly possesses energy, but in view of the fact that we can obtain work from it either by direct adiabatic expansion, or by keeping the volume constant and using the heat (for example) to operate a thermoelectric battery and a motor, it is scarcely logical to say that the energy of the original mass existed either in the form of heat or in the form of mechanical compression. If we try to solve this difficulty by replying that it existed in *both* forms, we are quickly made aware of the superficial nature

of the answer, if we attempt to determine *how much* is present as heat, and how much is present as mechanical compression. When we increase the energy of a body or system, we say that we "add energy" to it; and when we decrease its energy, we say that we "subtract energy" from it. We can always tell what form the energy has that we add or subtract, but it is often impossible to tell what form it has, while it actually resides within the body or system with which it is associated.

For purposes of measurement and computation it is necessary to have a satisfactory unit, in terms of which we can make definite quantitative statements with regard to energy; and in view of the definition of energy, it is evident that this unit must necessarily be either the same as the one that is used for measuring work or else a mere multiple or submultiple of it. The unit that is adopted in the measurement of work depends upon the nature of the problem that is under consideration. In modern scientific investigations the unit of work is commonly the erg, which is defined as the work done in overcoming a resistance of one dyne, through a distance of one centimeter. In engineering operations, the unit of work commonly employed (at least in the United States and in England) is the foot-pound, which is defined as the amount of work done in overcoming, through a distance of one foot, a resistance equal to the weight of one pound of matter. (In countries using the metric system, the unit of work in engineering operations is the kilogram-meter). The foot-pound is not as precise and definite a unit as the erg, because the attraction that the earth exerts upon a pound of matter varies with the latitude and with the elevation above the sea and hence the foot-pound varies in the same manner. The variation is not great enough, however, to destroy the usefulness of the foot-pound as a unit of work or energy for engineering purposes, and hence this familiar unit is not likely to be superseded, for ordinary, rough purposes. To avoid the indefiniteness of the foot-pound, we might adopt the far more scientific (but exceedingly uncommon) unit known as the "foot-poundal," which is defined as the quantity of work that must be done in order to overcome a resistance of one "poundal" through a distance of one foot—a "poundal" being the force which, when applied for one second to a body having a mass of one pound, subject to no other forces and initially stationary, will produce in that body a velocity of one foot per second.

A moving body possesses energy in virtue of its motion and work must be done by it before it will stop. Thus a railroad train, moving at high speed, cannot be brought to rest at once, because the energy of motion that it possesses must first be expended in overcoming the resistance of the brakes, or the natural frictional resistance of its axles in their journals and its wheels upon the tracks. The mechanical energy that a body possesses in virtue of its motion of translation or rotation is called "kinetic energy"; and that which it possesses in virtue of its position or its state of elastic strain is called "potential energy."

The kinetic energy of a body having a given mass and a given speed of translation, is (by definition) the amount of mechanical work that

the body must do, in order to come to rest. If the mass of the body is  $M$  and the velocity is  $V$ , it can easily be shown, from the principles of theoretical mechanics, that the work thus performed is  $\frac{1}{2} MV^2$ . This is therefore the numerical expression for the kinetic energy of the body. If  $V$  is given in feet per second and  $M$  is given in pounds, this formula gives the kinetic energy in foot-poundals; and hence if it is desired to state the result in foot-pounds, it is necessary to divide by the acceleration of gravity, as expressed in the same fundamental units—namely, by 32.2, in a locality in which the speed of a body falling freely in a vacuum increases, each second, by 32.2 feet per second.

It is not only impossible, in many cases, to state what form the energy has, within a given body or system, but it is also usually (and perhaps universally) impossible to say *how much* energy the body or system contains in the aggregate. In other words, there is usually no absolute and natural zero from which the energy can be reckoned; and hence we have to assume an arbitrary zero point, or else confine our attention to the quantities of energy added to the body or system (or subtracted from it), without making any attempt to estimate the total amount present. In the case of ordinary kinetic energy, there is apparently a natural zero, corresponding to absolute rest; but it will be evident that this zero is only conventional, inasmuch as "rest" is a relative term and a body that is seemingly quite devoid of motion is nevertheless rushing through space, with the earth, at a considerable speed. The case is even plainer in connection with the potential energy of a raised body. The body can do work by falling, but it evidently can do an indefinite amount of work by falling through an indefinite distance. In applying the principles of energetics to falling weights it is therefore conventional to assume some arbitrary level (at least as low as the lowest point to which the weight can go) as the level of zero potential energy. In the case of a pendulum, for example, we say that the bob has no potential energy when it is at the lowest point of its swing, for the simple reason that it cannot do more work by descending further, because it is already at the lowest point to which the construction and mounting of the pendulum will allow it to go; yet we know very well that it could do more work if the supports were removed and the pendulum as a whole were allowed to fall still further.

**Transformation of Energy.**—It often happens that energy of some one given and distinctly recognizable type may be transformed into energy of some other easily recognizable and definite type. The simplest example of a transformation of this kind is afforded by the case of a freely-falling body. The potential energy that the body possesses in virtue of its elevated position grows less as the body descends, and the kinetic energy that it possesses increases at the same time; and it is a simple matter to show, by the aid of elementary mechanical principles, that the gain in kinetic energy is precisely equal to the loss in potential energy. In the same way, an electric current flowing through a wire causes the wire to become heated and it has been proved that the heat-energy thus produced is precisely equivalent to the electrical energy

that disappears and which is not otherwise accounted for.

When energy is thus converted, it is found that there is always an exact relation between the quantity of energy of one type that disappears and the quantity of energy of the other type that appears. In fact, these two quantities are precisely equal, if they are both expressed in work-units—that is, in ergs or foot-pounds. As a matter of practical convenience, however, energy of a given special type is often measured in some special unit that lends itself, more readily than the erg or foot-poundal, to the particular measurements and approximate calculations that are associated with this species of energy. Heat is a familiar case in point, as it is commonly measured in terms of either the "British thermal unit," or the "calorie"—the British thermal unit being defined as the quantity of heat required to raise the temperature of one pound of water by one Fahrenheit degree, at a certain specified point on the thermometric scale, and the calorie being defined as the quantity of heat required to raise the temperature of one kilogram of water by one Centigrade degree, at some specified temperature. These units and others analogous to them, which are based upon obvious, directly-observable properties of substances and which do not involve any physical theories whatever might with propriety be called "natural units."

Owing to the fact that energy of one type may be transformed into energy of another type, it becomes exceedingly important to know the numerical relation between the "natural" units in which different forms of energy are measured; for until we possess this knowledge we cannot compare quantities of energy of different types—because we cannot express these quantities in terms of the erg, or foot-poundal, or any other common or fundamental unit. We should, in fact, be in the same position as a man who had measured one liquid with a gallon measure and another one with a pint mug, but who had no idea of the relation of the pint to the gallon.

It is especially important to be able to compare the "natural" unit of heat accurately with the erg or the foot-poundal, and many elaborate experimental researches have been conducted for the purpose of improving our knowledge of this relation. For full particulars with regard to this topic the reader should refer to HEAT and THERMODYNAMICS; but it may be said, in this place, that Rowland found that one British thermal unit of heat is the equivalent of about 778 foot-pounds of mechanical work—the "pound" here being understood to signify the attraction of the earth for one pound of matter, at sea-level in the latitude of Baltimore.

**Efficiency of Conversion.**—It is not always possible to convert a given quantity of energy of one type *wholly* into energy of some other given type, or wholly into mechanical work. Heat, for example, cannot be wholly converted into mechanical energy—though the reverse process, of converting mechanical energy wholly into heat, is easily performed. This fact has led to the use of the expression "available energy," to signify that part of the total energy of a body or system, which can be converted into mechanical energy. The distinction between available and unavailable energy is arbitrary, however, because the

fraction of the total energy that is available depends upon the completeness of our control over the conditions under which the transformation is attempted. Heat energy, for example, could be wholly converted into mechanical energy (so far as any theoretical limitation is concerned), if we could effect the transformation by means of a heat-engine having a condenser at the absolute zero of temperature, and in that case all the heat-energy would be "available." Similar limitations and conditions apply to energy of other types. The fact that heat-energy is not fully convertible into mechanical energy under conditions that we can realize, or which exist in nature, while the reverse transformation takes place quite readily and completely, leads to the recognition of the fact that in the processes of nature there must be, on the whole, a tendency toward the "degradation of energy," in the sense that there is a continuous diminution, in the universe, of the store of available energy. The supply of available energy, in other words, is tending continually to become dissipated, in the form of diffused, low-temperature heat.

For purposes of mathematical analysis, it is convenient to designate the condition of a body or system by representing, by means of algebraic symbols, its configuration, size, temperature, electric potential, and any other measurable attributes that it may have—the particular attributes or features that are selected being to a considerable extent arbitrary, though to serve the purpose of defining the condition of the body or system at every moment, they must be numerous enough, and must be selected in such a way, so that no change, essential to the problem under consideration, can take place in the body without at least one of these symbols (or defining variables) changing its value. It may be that some of the selected variables will be functionally dependent upon the others; but there will always be a certain number (small in the cases usually considered) that will be independent, so that any one of them can vary without any of the others necessarily undergoing a simultaneous variation. Then if  $E$  represents the aggregate energy (including all types) possessed by the body at a given moment, and if the body then undergoes an infinitesimal change of condition so that  $E$  increased by the theory of energetics teaches that a relation of the following form exists:

$$\Delta E = X \cdot \Delta x + Y \cdot \Delta y + Z \cdot \Delta z + \dots$$

where  $X, Y, Z, x, y, z, \dots$  are functions of the independent defining variables—some of them being perhaps *identical* with certain of those variables. The symbols on the right-hand side may be so selected that each of the several expressions that are added together will represent the total quantity of energy of some one type that the body must take in, in order to undergo the physical change corresponding to an increase of  $x, y, z, \dots$  by the respective amounts  $\Delta x, \Delta y, \Delta z, \dots$ . The variables, moreover, may be so chosen that  $X, Y, Z$ , will be analogous to *intensities*, in the sense that they do not depend in any way upon the mass or volume of the body, but only upon its physical state; and for this reason they are called the "intensity-factors." At the same time the infinitesimals  $\Delta x, \Delta y, \Delta z, \dots$  (since the dimensions of every one of the added terms must be the same as the dimensions of energy) will be proportional to the volume of the body, or to

its mass, or to some other quality or attribute that would necessarily vary if the size of the body should vary, without any change in  $X$ ,  $Y$ ,  $Z$ , . . . . The terms  $\Delta x$ ,  $\Delta y$ ,  $\Delta z$ , are therefore called the "capacity factors" of the terms on the right of the equation. Furthermore, the intensity-factor  $X$  will be of such a nature that its value within the body, as compared with its value in the environment immediately external to the body, determines whether the energy represented by  $X \cdot \Delta x$  will enter the body or leave it.

By way of elucidation, let us consider the case of a "perfect gas," subject to variations such that any two of the three variables pressure, temperature and volume, will suffice to define its condition at any given moment; and let us assume that the only forms of energy to be considered are heat-energy and the energy of elastic compression. Then the foregoing equation takes the form

$$\Delta E = T \cdot \Delta \phi - p \cdot \Delta v,$$

where  $T$  is the absolute temperature,  $\phi$  is the entropy,  $v$  is the volume of the gas, and  $p$  is the pressure to which it is subject, per unit of its bounding surface. (See THERMODYNAMICS). The first term on the right is then the quantity of heat-energy absorbed, and the second is the quantity of compression-energy absorbed. (The negative sign is affixed to the last term because we are considering the energy added to the system, and the internal energy due to compression increases when  $v$  decreases).

If the body or system undergoes any kind of a cyclic change, such that its final state is in all respects identical with its initial state, then the algebraic sum of all the changes of  $E$  (the internal or intrinsic energy), summed up for the entire cycle, will be zero; for if this were not the case, then by causing the body to pass around the cycle repeatedly, in one certain direction, we could obtain an indefinite supply of energy from it; and this would violate the principle of the conservation of energy. (See below). Suppose, now, that in the special case we are considering, the body undergoes the following cycle: (1) With its temperature constantly equal to  $T_1$  it passes from the state in which  $\phi = \phi_1$  to the state in which  $\phi = \phi_2$ ; (2) with  $\phi$  constantly equal to  $\phi_2$  it passes from the state in which  $T = T_1$  to the state in which  $T = T_2$ ; (3) with  $T$  constantly equal to  $T_2$  it passes from the state in which  $\phi = \phi_2$  to the state in which  $\phi = \phi_1$ ; and (4) with  $\phi$  constantly equal to  $\phi_1$  it returns to its initial state, so that  $T$  changes from  $T_2$  to  $T_1$ . In each stage the heat absorbed will be obtained by integrating along the path that is followed. Thus in the first stage  $T_1(\phi_2 - \phi_1)$  units of heat will be absorbed. In the second stage there will be no heat absorbed, because  $\phi$  does not change. In the third stage  $T_2(\phi_1 - \phi_2)$  units of heat will be absorbed; and in the final stage no heat will be absorbed. But as  $T$ , the absolute temperature, is essentially positive, it follows that  $T_2(\phi_1 - \phi_2) = -T_2(\phi_2 - \phi_1)$  is negative, if  $T_1(\phi_2 - \phi_1)$  is positive. Hence if heat enters the body during the first stage of the cycle, heat is rejected by the body during the third stage. The amount of heat that is absorbed in the course of the whole cycle is  $T_1(\phi_2 - \phi_1) - T_2(\phi_2 - \phi_1) = (T_1 - T_2)(\phi_2 - \phi_1)$ , and in view of the principle of

the conservation of energy, this must have been converted into some other form of energy. But it is not represented by any increase in the internal energy of the body, because a complete cycle has been described, and the body has returned to its original state. Hence it has been transformed into mechanical energy. The only heat that has entered the body (in the positive direction) is the quantity taken in during the first stage of the cycle. Hence the efficiency of the conversion of heat-energy into mechanical-energy is

$$\frac{(T_1 - T_2)(\phi_2 - \phi_1)}{T_1(\phi_2 - \phi_1)} = \frac{T_1 - T_2}{T_1}$$

The cycle we have here considered is known as the Carnot cycle, being named for the distinguished French founder of the mechanical theory of heat, who first employed it. An analogous cycle can easily be applied to any other type of energy.

In the foregoing discussion we have assumed that the processes considered are *reversible*, and that any change can take place in either the positive or negative direction. The theory of irreversible changes is too involved to be considered in the present article—and in fact it has not yet been completely worked out.

**Conservation of Energy.**—The physical law that is known by this name asserts that the total amount of energy in any isolated system is absolutely invariable in amount. Energy may be added from without, or abstracted in a similar manner; but so long as no external influences are permitted to interfere, the total quantity of energy within the system is incapable of either increase or diminution. In a simple case like that of the pendulum this is easily admitted; but other systems are easily imagined, in which the truth of the law is by no means obvious. For example, a tightly-wound watch-spring possesses potential energy, in virtue of which it may be caused to drive a train of wheels and to do work. But suppose the coiled watch-spring is dissolved in an acid and meanwhile secured in some manner so that it cannot unwind. What becomes of the energy in the spring? This question would be best answered by experiment; but in the absence of experimental data the conjecture may be reasonably made that the two sides of the spring, being in different states of strain, act like plates of different metals when immersed in the acid and give rise to electric currents through the liquid, whose combined chemical and thermal effects correspond precisely to the potential energy that was stored in the spring by winding. The simpler case of a body falling freely in a vacuum is also somewhat confusing at first thought, because although it may be admitted that the potential energy is used up by accelerating the body while it is falling, it is by no means evident that the accumulated kinetic energy is not annihilated as soon as the body strikes the ground. But the energy of the falling body is converted into heat when the visible motion is suddenly arrested, and the body and the ground immediately around it are warmed by an amount that corresponds precisely to the kinetic energy that the body had immediately before the arrest. This explanation is not merely speculative, for it rests upon sound experimental evidence. The arrest of a

cannon-ball is accompanied by the generation of enormous quantities of heat, and the wood-work on battleships is often set afire in consequence of the mere impact of projectiles. The water at the bottom of a waterfall is measurably warmer than that at the top; and the rise in temperature that is observed when a falling mass of lead is suddenly arrested was used by Hirn with remarkable success for the determination of the mechanical equivalent of heat.

The idea that energy cannot be created appears to have been familiar to Galileo, who inferred the fact from a careful study of the simple machines that were in use in his day. There appeared to be many cases in which energy is destroyed, however, and the indications were, in fact, that all mechanical energy is gradually wasted away by frictional losses and by others of like nature. In cases in which these losses do not exist, or are negligible, the idea of the conservation of the energies of a system, and of the perpetual transformations of kinetic energy into potential energy and the reverse, proved to be of the greatest service in simplifying the theoretical discussion of many problems in mechanics, even before the modern theory of heat was formulated. The motions of the celestial bodies, for example, are much more easily discussed by the aid of the principle of conservation of energy than they could be without it. The extension of that principle so as to cover all the cases in which it had previously appeared to be violated could not be made until the fact was recognized that heat is not a substance; for, obviously, it was impossible that a substance could be converted into mechanical energy. In the first years of the 19th century Rumford made experiments tending to prove that heat is not a substance, and he appears to have been convinced, in his own mind, of the correctness of his novel views. A quarter of a century later Carnot probably reached the same conclusion, if we may judge from the note-book that he left among his papers. It was not until about 1840, however, that the great steps were taken that led to the establishment of our present views. Several eminent names are connected with these beginnings of the modern theory of heat and it is difficult to apportion the credit among them justly. Prominent among these names are those of Séguin, Mayer, Colding and Joule; but it is undoubtedly to Mayer and Joule that we are chiefly indebted for the new ideas, and the controversies that were rife at one time concerning the credit that should be given to different investigators for their work along this line were mainly confined to a discussion of the priority and the relative importance of the contributions of these two men.

Dr. Julius Robert Mayer, an obscure physician of Heilbronn, Germany, who had had some professional experience in the island of Java, had observed that the venous blood of the Javanese often exhibits the brilliant red color that is commonly observed only in the highly oxygenated blood of the arterial circulation; and after much reflection he came to the conclusion that this is because a lesser amount of oxidation suffices to maintain the temperature of the body in a hot climate than would be required in a cooler one. These observations were made in the summer of 1840. In May

1842 he published, in Liebig's *Annalen*, a paper entitled 'Remarks on the Forces of Inorganic Nature,' in which he gave a preliminary account of his discovery. Here he presents the general outline of the new theory very clearly, and the grasp of the subject that he displays at this early date is truly wonderful. The locomotive itself was then a great novelty, but he uses it to illustrate the transformation of heat into mechanical energy and back again in the following sentence, which would be a credit to the most advanced physicist of to-day: "Our locomotives may be compared to distilling apparatus; the heat beneath the boiler passes into the motion of the train, and is again deposited as heat in the axles and wheels." In 1845 he published a second and much more remarkable paper entitled 'Organic Motion in its Connection with Nutrition,' in which he gives a detailed calculation of the mechanical equivalent of heat, from the known specific heats of air.

The contributions of James Prescott Joule, of Manchester, England, to the mechanical theory of heat and the conservation of energy were the natural outcome of investigations that he had been making upon the heating effects of electric currents. His first paper that distinctly enunciated the new conception of heat as a form of energy was read at Cork, in 1843, before the British Association, and was entitled 'On the Calorific Effects of Magneto-Electricity, and on the Mechanical Value of Heat.' As first written it was very involved, and Faraday, who appears to have failed to grasp its exceeding importance, advised Joule not to submit it. He did submit it, however, and in it he gave a number of estimates of the mechanical equivalent of heat. The paper apparently did not greatly impress either the British Association or the outside world; for when Joule brought the subject up again before the same association in 1847 he had an experience that is best described in his own words: "The chairman suggested that, as the business of the section pressed, I should not read my paper, but confine myself to a short verbal description of my experiments. This I endeavored to do, and discussion not being invited, the communication would have passed without comment if a young man had not risen in the section, and by his intelligent observations created a lively interest in the new theory." The young man was Lord Kelvin, then simply William Thomson, two years out of college. In later years Joule obtained far better values for the mechanical equivalent of heat, and spent much of his time devising and executing new methods for its determination.

In England and the United States Joule is commonly credited with the discovery of the true nature of heat; but in Europe the honor is frequently given to Mayer. Tyndall compares the two very fairly. "Withdrawn from mechanical appliances," he says, "Mayer fell back upon reflection, selecting with marvelous sagacity, from existing physical data, the single result on which could be founded a calculation of the mechanical equivalent of heat. In the midst of mechanical appliances, Joule resorted to experiment, and laid the broad and firm foundation which has secured for the mechanical theory the acceptance it now enjoys. A great portion of Joule's time was occupied in actual manipulation; freed from this, Mayer had time to

follow the theory into its most abstruse and impressive applications. With their places reversed, however, Joule might have become Mayer, and Mayer might have become Joule."

In 1847 Helmholtz published his remarkable paper entitled 'On the Conservation of Energy,' in which the subject was presented with great generality and clearness, and which had a profound influence in spreading the new doctrine which taught that no energy is ever created or annihilated, but that we have to do merely with endless transformations of it from one form into another. Attempts have been made to deduce the principle of the conservation of energy from the general laws of mechanics, and in many special cases these attempts have been successful, though they cannot be in all cases, because systems are easily imagined in which the law is not fulfilled. The point is, however, that these imaginary, non-conservative systems apparently do not exist in nature. In allusion to the twofold nature of the subject (that is, the mathematical and physical aspects), it has been humorously said that everybody believes firmly in the conservation of energy, because the mathematicians believe it to be a fact of observation, while the physicists believe it to be a theorem in mathematics. It is now generally admitted, however, to be a fact of observation, the truth or falsity of which is to be established by experiment. Helmholtz proved that in any system composed of particles moving about in paths or orbits, and subject only to "central forces" (that is, to forces that act always toward fixed centres or foci, or which act, between every pair of particles, along the line adjoining their centres), the energy must be conserved, if the ordinary laws of theoretical mechanics hold true for the motions of the particles of which the system consists. Hence, if it be admitted that all matter consists of atoms that act upon one another only by forces that are central, a long step has been taken toward proving the law for all material systems. Unfortunately, however, we are not sure that central forces are the only ones that act upon the atom. It is an interesting fact that it was the study of the processes of organic nature that gave Mayer his first inspiration concerning the true nature of heat, and yet it is precisely here that the only doubt as to the entire generality of the law of conservation now exists. The most general test that can be applied to a system to enable us to judge from theoretical considerations whether it is conservative or not is this: Let the system be protected from external influences, and then, at a given instant, conceive the motion of every one of its particles to be precisely reversed in direction, without being modified in any other way. If, when left to itself, the system would then retrace its previous history so that the events of that history would recur in reverse order, the conservation of energy is rigorously fulfilled in it. If, on the other hand, the system would not so retrace its history, we cannot affirm that it is conservative, but must test the point by a direct appeal to experiment. Now, although this crucial condition is frequently fulfilled in inorganic nature, we certainly cannot assert it to be true in connection with living matter, even with respect to the meanest fungus. Hence we cannot, from reasoning based on the inorganic world alone, draw any sound conclusion whatever about the

conservation of energy in the organic changes that occur in living tissues. To reach such conclusions for the living animal, we must weigh and analyze the food administered and the excreta given off; we must determine the oxygen absorbed and the carbon dioxide and other products exhaled; and we must measure the heat given out and the external work performed. When these things have been weighed, measured and analyzed for a sufficient period and with the necessary precision, then, and then only, shall we be competent to affirm or deny the truth of the conservation of energy in the animal machine. Such data are difficult to obtain, but much has been done in this direction, and while we are not yet prepared to establish it as a fact, beyond controversy, that energy is conserved in the animal body, all the data that we have point to this conclusion and it is now commonly admitted to be true.

The fact that energy (like matter) cannot be either created or destroyed has led physicists to speak of it as though it were a real thing, having an objective existence. It is useful to think of it in this way, and convenient to speak of "converting" energy from one form into another. In reality, however, it is no more a real thing than is momentum, or "action" (which figures prominently in modern theoretical mechanics). In pure mathematics the theory of transformations makes us familiar with the idea of "invariant" functions and configurations, which retain their forms or values when subjected to the given transformations. It is more logical to think of energy as being a similar invariant under the physical transformations that the existing universe and its contents can undergo. If this be admitted, then the discussions that are now often encountered, in which the possibility of energy having a molecular structure is considered, must be taken in a figurative sense only. It is quite possible that it is given out discontinuously in connection with radiation phenomena, just as the water handled by a "bucket brigade," at a fire, is delivered discontinuously; but the question as to whether or not energy has a molecular structure, or a structure of any other kind, appears to have no physical meaning, when interpreted in any strict sense. (For the "quantum hypothesis" of Planck, see RADIATION). For an interesting expression of Planck's own view on the molecular-structure conception, after he had given it mature thought, consult his 'Leçons de thermodynamique,' Chevassus' translation, 1913, page 307.

The first systematic paper on the general theory of energetics (as distinguished from writings on the conservation of energy and on the mechanical theory of heat) was Rankine's 'Outlines of the Science of Energetics,' read before the Philosophical Society of Glasgow on 2 May 1855, although Rankine, two years before that time, had read, before the same society, a somewhat analogous paper containing the germs of the later one, and entitled 'On the General Law of the Transformation of Energy.' The phrase "potential energy" occurs in the earlier of these papers, for the first time.

**Bibliography.**—Carnot, 'Reflections on the Motive Power of Heat' (Thurston's translation); Clausius, 'Mechanical Theory of Heat' (Browne's translation); Duhem, 'Traité élémentaire de mécanique chimique,' and 'Le

potentiel thermodynamique'; Gibbs, 'On the Equilibrium of Heterogeneous Substances'; Helm, 'Die Energetik'; Helmholtz, 'Ueber die Erhaltung der Kraft'; Joule, 'Scientific Papers'; Nernst, 'Theoretical Chemistry,' and 'Thermodynamics and Chemistry'; Stewart, 'The Conservation of Energy'; van't Hoff, 'Lois de l'équilibre chimique.' See also MECHANICS; PERPETUAL MOTION; RADIATION; RADIOACTIVITY; THERMODYNAMICS.

ALLAN D. RISTEEN,  
Director Technical Research, The Travelers  
Insurance Company.

**ENERGISM**, the name given by many philosophical writers to the neo-Aristotelian view concerning the chief ultimate goal of human life. It is summed up in the dictum, "the goal at which the will of every living creature aims is the normal exercise of the vital functions which constitute its nature." Energism is opposed to Endæmonism, which puts pleasure as the chief goal of human life. Consult Paulsen, 'System der Ethik' (Berlin 1894; English trans., 1899).

**ENERGUMEN**, ěn-ěr-gū'měn, a person controlled or "worked up" (*ενεργούμενος*) by evil spirits. The word is in common use in the writings of the Greek and Latin fathers; it is equivalent to the (*δαίμονιζόμενος*) (possessed by a devil) of the New Testament. In the 3d century the churches kept registers of their energumens and dealt with them much as though they were lepers; they were supported by the alms of the faithful and lodged in dwellings near the churches. The treatment of energumens and their relationship to the Church was discussed at and regulated by a number of synods, especially by that held at Orange in 441 and usually known as Concilium Arausicana. See EXORCISM. Consult Hefele, K. J., 'A History of the Councils of the Church' (translated by W. R. Clark and others, Vol. III, Edinburgh 1883).

**ENERGY**, Conservation of. See ENERGETICS.

**ENEURESIS**, a symptom of many diseases of the bladder resulting in incontinence or involuntary passing of urine. It is a prevalent malady of childhood and only becomes of importance after the period of infancy, when the child should have learned to control the bladder. The control of the bladder is in part a matter of conscious effort, and has its representation in the higher brain-centres. Bladder-control is also exercised by that portion of the sympathetic nervous system found in the solar and sacral plexuses, and likewise in a number of cells in the spinal cord situated in the lumbar region. Interference with the action of any or all of these centres may result in eneuresis. Disease of the spinal cord may cause excessive irritation of the sympathetic nervous system and may result in nocturnal eneuresis, and the cutting off of the cerebral control may also bring about this condition. During deep sleep the cerebral control is usually cut off, accounting thus for the prevalence of eneuresis in deep sleep in children. Very frequently the immediate cause of eneuresis is some form of local irritation. This is particularly prevalent in young girls, and should always be removed, if possible, in the treatment. Drug medication is

extremely unsatisfactory for this condition. The most efficient measures consist in building up the general nervous system of the patient by tonics, cold baths and exercise in the open air.

**ENFANTIN**, ɔ̃n-fɔ̃n-tã̃n, **Barthélemy Prosper**, French socialist of the Saint-Simon school: b. Paris, 8 Feb. 1796; d. there, 31 May 1864. He was the son of a Paris banker, and after studying for some years at the École Polytechnique went into business. After traveling extensively for a number of years he settled in Paris in 1823. In 1825 he first met Saint-Simon (q.v.) and became strongly interested in his political and economic theories. After the July revolution of 1830 Enfantin associated himself with Bazard for the active propagation of Saint-Simonism. They became the supreme heads of the sect. Bazard expounded it in its relations to philosophy and politics; Enfantin mainly in its relations to the social state. They established a paper, called *Globe*, in which they propagated their views. Soon, however, a schism broke out between the two on the question of marriage and the relation of the sexes, for his views on which Enfantin was, in 1832, sentenced to one year's imprisonment and to pay a fine of 100 francs. This broke up a model community, which, together with 40 of his disciples, he had founded at Ménilmontant after the break with Bazard and where he was known as "Le père." Being released from prison at the expiration of a few months he went to Egypt. He was subsequently appointed a member of the scientific commission for Algiers, and on his return from Africa published 'Colonization of Algeria' (Paris 1843). At this time he became again actively interested in business and in 1845 was made director of the Paris-Lyon Railway. After the revolution of 1848 he founded and edited the journal *Le Crédit*, which stopped publication in 1850. He was then made administrator of the Lyon Railway, in which position he was quite successful and which he occupied until his death. His library of 1,018 volumes and 63 manuscripts he left to the Library of the Arsenal at Paris. His various writings, all on economic and political subjects, have been published together with those of Saint-Simon as 'Oeuvres de Saint-Simon et d'Enfantin' (47 vols., Paris 1865-78). Consult Howse, E. S., 'Enfantin and Saint-Simon' (in *Theological Review*, Vol. IX, p. 50, London 1872).

**ENFANTS DE DIEU**, ɔ̃n-fã̃n-dě-dyě, a name of the French Camisards (q.v.).

**ENFANTS PERDUS**, per-dü ("lost children"), in military parlance the men appointed to perform some exceedingly hazardous duty from which their chances of returning safely are practically nil. Our English equivalent phrase is "a forlorn hope."

**ENFEOFFMENT**, ěn-fěf'měnt, (1) the act of bestowing or investing with a freehold estate; (2) the instrument or deed by which such estate is conveyed; (3) the estate so conveyed. See FEE-SIMPLE.

**ENFIELD**, Conn., town in Hartford County, on the Connecticut River and the New York, New Haven and Hartford Railroad, 15 miles north of Hartford. Its chief manufactures are carpets shoddy, powder, filter

presses, supplies for undertakers and bicycles, and it has large brick works. A large amount of the now celebrated Connecticut tobacco is here prepared for use and shipped to different parts of the world. Shaker Station is a part of the town (see SHAKERS). It contains a Carnegie library. The government is administered by town meetings. Pop. 11,006.

**ENFIELD**, England, a market town in the county of Middlesex on New River, nine miles northeast of London. Enfield is the seat of the well-known government manufactory of rifles and small-arms, and the standard rifle used in the British army is made here. At Cuffley, three miles north of Enfield, the first Zeppelin to be brought down on English soil was shot down on 3 Sept. 1916 by Flight-Lieutenant Robinson, who was awarded the Victoria Cross for the daring deed. The airship fell headlong, sinking to the ground in flames, and the members of the crew burned to death. Some noted people have lived in Enfield. See BEACONSFIELD; LAMB; KEATS. Pop. 56,388.

**ENFIELD RIFLE**, a muzzle-loading rifle used in the British army prior to the introduction of the breech-loading system. It was also used in the United States during the Civil War by the Northern army, when Springfields could not be obtained, and by the Confederate army. In England large numbers of these rifles were converted into breech-loaders on the Snider principle and were known as the Snider-Enfield or simply Snider. The Enfield rifle must not be confused with the recent British Lee-Enfield, which is a modified Mauser.

**ENFILADE**, *ën-fi-läd'* (from the Fr. *enfiler*), in the military art, is to rake by fire the enemy's trenches or positions along the whole length. In conducting the approaches at a siege care must be taken that the trenches be not enfiladed from any part of the place besieged. To avoid this they are generally cut in a zigzag. The same principle holds true of trench warfare, where the boyaux or communicating trenches are zigzagged and the firing trenches are interrupted by traverses.

**ENFLEURAGE**, *ön-flé-rähz*, in perfume-making, the method of extracting by contact and absorption the scents of flowers used for perfumery. For this purpose wooden frames containing glass smeared with pure grease are filled with flowers, which are allowed to remain from one to six days. The grease gradually absorbs the scent, the flowers being renewed from time to time. The scent is afterward separated from the grease by soaking the latter in strong spirits of wine. Sometimes wire frames covered with cotton cloths, saturated with fine olive-oil, are used instead of glass. In this manner the most delicate odors are extracted from flowers which would be lost in the process of distillation. This process is employed especially in the south of France. It is rather complicated, and has the disadvantage of permitting the flowers to come into direct touch with the grease and imparting to it possibly some impurities. In modern perfume factories the process of enfleurage, therefore, is frequently accomplished by placing flowers and grease in separate containers. A current of air is created by means of an exhaust fan in such a manner that it passes first over the flowers

and later over the grease, which latter rapidly absorbs the odors originated by the flowers. Another method consists of passing a current of carbonic acid gas through a tin box containing fresh flowers and then into a glass jar of strong alcohol cooled by water. The carbonic acid absorbs the odors of the flowers, which, in turn, is absorbed by the alcohol. Consult Askinson, G. W., 'Perfumes and Cosmetics, their Preparation and Manufacture' (translated from the German by W. L. Dudley and others, New York 1915); Rolet, A. V., 'Les Essences et les Parfums' (Paris 1907); Piesse, G. W. S., 'Chimie des Parfums et Fabrication des Essences' (Paris 1917).

**ENG AND CHANG**. See SIAMESE TWINS.

**ENGADINE**, *ën-gä-dën'*, a beautiful valley in Switzerland, in the Grisons, on the banks of the Inn, bordering on the Tyrol. The extent of the valley is 60 miles and it has an area of 653 square miles. The language generally spoken is the Ladin, a branch of the Romanic tongue. Several towns and villages are situated in the valley, which is visited by numbers of strangers on account of its picturesque beauty and its mineral springs as well as its invigorating climate. Pop. 12,193.

**ENGAGEMENT**. See BETROTHMENT.

**ENGAGEMENT**, *Military*, a minor battle or encounter in which all the parts or divisions of the contending armies do not have a part. Engagements or skirmishes usually occur when major forces are being manœuvred for position to secure the advantage in a pitched battle. See MILITARY SCIENCE; TACTICS, MILITARY.

**ENGANO**, *ën-gä'ño*, an island of the Malay Archipelago, 60 miles south of Sumatra. It is covered with forests and surrounded by coral reefs; area, including several small adjacent islands, 300 square miles. The natives are Malays.

**ENGEDI**, *ën-gē'dī* or *ën'gē-dī* (Heb. "Fountain of the Goat"), on the western shore of the Dead Sea, about 30 miles southeast of Jerusalem. The modern Arabic name is Ain-Jidy. The ancient name was applied also to the eastern part of the wilderness of Judah. The city in the time of Abraham was called Hazazon-tamar (Gen. xiv, 7), the tamar meaning palm tree. In 1 Samuel xxiv mention is made of David fleeing into the wilderness of Engedi to escape from Saul. There are numerous other references to the place in the Old Testament. In modern times nothing remains except the never-changing effectiveness of the scenery arising from the combination of steep cliffs, the Dead Sea, strange vegetables, balmy air and almost excessive quietness. Consult Robinson, E., 'Biblical Researches in Palestine, etc.' (Vol. II, Boston 1841); Wilson, Sir C. W., 'Picturesque Palestine' (Vol. I, London 1884).

**ENGEL**, *Ernst*, German statistician: b. Dresden, 1821; d. Berlin, 1896. After a preliminary education he took up the study of mining engineering at Freiberg and Paris. For a time he was a member of the commission investigating industrial and labor conditions in Saxony, and in 1850 was appointed chief of the Royal Bureau of Statistics at Dresden. He resigned in 1858 and was made chief of the Saxon



Mortgage Insurance Company, but two years later became director of the Prussian Bureau of Statistics, from which he retired in 1882. He was one of the most efficient of modern statisticians and his investigations into the social condition of the working classes have proved invaluable. He wrote 'Die Methoden der Volkszählung' (1861); 'Land und Leute des Preussischen Staates' (1863); 'Das Zeitalter des Dampfes' (1881).

**ENGEL, Franz**, German explorer: b. Röbel, Mecklenburg-Schwerin, 1834. He traveled extensively in South America in the years 1857-63 and published the results of his explorations in several valuable volumes, including 'Studien unter den Tropen Amerikas' (2d ed., 1879); 'Aus dem Pflanzersstaate Zulia' (1881). From 1872 to 1896 he published the *Landwirthschaftliche Jahrbücher*.

**ENGEL, Johann Christian von**, Hungarian historian: b. Teutschau, Hungary, 1770; d. 1814. He received his education at the University of Göttingen, where Heyne and Schlözer were among his teachers. He wrote several historical works which in their day were treasure-houses of knowledge and scholarship. He was the first to put the history of Hungary on a sound scholarly basis. In 1812 he was ennobled. His greatest works are 'Geschichte des ungarischen Reiches und seine Nebenländer' (5 vols., 1797-1804); and 'Geschichte des Königreichs Ungarn' (5 vols., 1814).

**ENGEL, Johann Jakob**, German prose writer: b. Parchim, 11 Sept. 1741; d. there, 28 June 1802. On the accession of King Frederick William III of Prussia, whose tutor he had been, he was invited by his former pupil to Berlin, where he made himself exceedingly useful in the Academy of Sciences by his writings. Among his philosophical works may be mentioned his 'Der Philosoph für die Welt,' distinguished for acute observations on men and manners, enlivened by elegant illustrations. Of a similar character is his 'MIRROR for Princes' (Fürstenspiegel). His 'Ideen zu einer Mimik,' full of taste, acuteness and knowledge of human nature, may be regarded as a kind of manual for actors. Anxious to make the German theatre the mirror of the national life, he wrote several plays, but they were of little merit—'Der dankbare Sohn'; 'Edelknaben,' etc. His 'Lorenz Stark,' a novel, is a masterly picture of life and manners. A complete edition of his works appeared at Berlin (1801-06).

**ENGEL, Joseph**, Austrian anatomist: b. Vienna, 1816; d. 1899. He was appointed professor of anatomy at Zürich in 1844 and later the chair of physiology fell to him also. Five years afterward he was appointed to the chair of pathological anatomy at the University of Prague. In 1854 he became professor of anatomy at the Josephakademie, Vienna, in which position he remained until 1874. He made many important contributions to the systematization of anatomical science and its study. His principal works are 'Lehrbuch der pathologischen Anatomie,' and 'Kompendium der topographischen Anatomie' (1859).

**ENGEL, Karl Dietrich Leonhard**, German musician and writer: b. grand duchy of

Oldenburg, 21 Feb. 1824. He went to Russia as a violin virtuoso at the age of 18, becoming a member of the Imperial Orchestra at Saint Petersburg at 22, and later its concert-master. He went to Dresden in 1869 and took up his residence there. Among his works are 'Deutsche Puppen Komödien' (1874-93); 'Das Volksschauspiel Doktor Johann Faust' (2d ed., 1882); 'Zusammenstellung der Faustschriften vom 16 Jahrhundert bis Mitte 1884' (2d ed., 1884); 'Die Don Juan Sage auf der Bühne' (1887). His musical compositions include a concerto in B minor and the humorous fantasy entitled 'Jüdischer Carneval.'

**ENGELBERG**, Switzerland, a noted health resort, situated in Unterwalden Canton, in the Engelberg Valley, about 3,500 feet above sea-level, and 15 miles south of Lucerne. It is the seat of a Benedictine monastery, dating from the 12th century, with a library of 20,000 volumes, including incunabula and manuscripts of great value. Connected with the monastery is a gymnasium which was founded in the 11th century. Cheese-making is the main industry. Pop. 2,500.

**ENGELBERT**, Bohemian monastic author: b. Völkersdorf, Styria, about 1250; d. 1331. He received his education at Prague and Padua, entered the order of the Benedictines and in 1297-1327 was abbot of Admont, Styria. He is best known to scholars through his Roman history; entitled 'De Ortu, Progressu et Fine Imperii Romani,' which has gone through numerous editions. For other works of this author consult 'Thesaurus Anecdotorum Novissimus' (1721) and 'Bibliotheca Ascetica Antiquo-nova' (1723-25).

**ENGELBERT, Saint**, archbishop of Cologne: b. Berg, 1185; d. 1225. In 1206 he was excommunicated, but was restored to friendly relations with the Church and reinstated two years later. In 1216 he was appointed archbishop of Cologne. He was one of the most progressive men of his age; he greatly improved the administration and governmental methods of his see; patronized agriculture, the industries and art, and opposed the repressive and cruel methods of the feudal barons. He reformed the electorate and after 1220 was administrator of the empire. In 1222 he crowned Henry VII. He was assassinated by hirelings of his nephew whom he had accused of maladministration. He is commemorated as a martyr on 7 November, although he has never been formally canonized. Consult Stoffel, 'Engelbert der Reichsverweser' (Elberfeld 1893).

**ENGELBRECHT, Theodor Heinrich**, German geographer: b. Obendeich, Schleswig-Holstein, 1853. He acquired his education at the universities of Leipzig and Strassburg, and in 1911 received the honorary degree of doctor from the University of Breslau. In 1895 he became a member of the Free Conservative party in the House of Deputies. His works include 'Die Landbauzonen der aussertropischen Länder' (3 vols., 1899), a valuable work on the study of agriculture in Europe; 'Die geographische Verteilung der Getreidepreise' (2 vols., 1908), the first volume dealing with the United States, the second with India; 'Boden-

bau und Viehstand in Schleswig-Holstein' (1905).

**ENGELBRECHTZEN**, ɛng'ɛl-breht-zɛn, Cornelis, Dutch painter: b. Leyden, 1468; d. there, 1533. He was the son of the wood-engraver Engelbert, and the teacher of Lucas, being the earliest known painter in Leyden and the first of his nation to use oil colors. Many of his works were destroyed during the Reformation, and the only two properly authenticated pictures of large size are altarpiece with 'Crucifixion' and altarpiece with 'Pieta,' Town Hall, Leyden. Doubtfully attributed to him are 'St. Leonard,' Antwerp Museum; 'Crucifixion,' old Pinakothek, Munich; 'Deposition,' Moritz Chapel, Nuremberg; 'Madonna and Child,' National Gallery, London; 'Crucifixion,' Venice Academy. The Van Leydens were his pupils.

**ENGELHARD, Friedrich Wilhelm**, frɛd'riħ vil'hɛlm ɛng'ɛl-hɛrt, German sculptor and painter: b. Grünhagen, Prussia, 19 Sept. 1813; d. 22 Jan. 1902. He studied at Hanover, at Copenhagen with Thorwaldsen and at Munich with Schwanthaler. He executed many groups, single figures and genre pieces. Among his creations are 'Love on a Swan'; 'Dancing Springtime'; 'Slinger with Dog'; 'Bacchus Conquering a Panther'; 'Cupid and Psyche'; the frieze of the 'Edda,' his chief work; 'A Child Fishing'; 'A Child Threading a Needle'; statue of 'St. Michael'; portrait medallion of Bismarck for the monument of Canossa, near Harzberg; 'Christ Blessing Little Children'; and the legendary characters of Germany, 'Odin,' 'Thor' and the Valkyries.

**ENGELHARDT, Georg von**, Russian statesman: b. Riga, 1775; d. 1862. He went to Saint Petersburg in 1790 and six years later secured a post in the Department of Foreign Affairs. He became Undersecretary of State in 1801 under Alexander I. He was made director of the Pedagogical Institute in 1811 and of the Lyceum at Tsarkoe-Selo in 1816. His liberalism, however, led to his removal in 1823. From 1838 to 1852 he edited the *Russische Landwirtschaftliche Zeitung*. He published 'Russische Miscellan zur Kenntnis Russlands und seiner Bewohner' (4 vols., 1828-32) and edited the manuscript journals of the explorer, Wrangel, which he issued in 'Reise längs der Nordküste von Sibirien und auf dem Eismeer' (1839).

**ENGELHARDT, Johann Georg Veit**, German theologian: b. Neustadt-an-der-Aisch, Bavaria, 1791; d. Erlangen, 13 Sept. 1855. In 1822 he became professor of theology at Erlangen; during the years 1845, 1847 and 1848 was the representative of his university in the diet at Munich. His most celebrated works are a translation of the writings ascribed to Dionysius the Areopagite; 'Handbuch der Kirchengeschichte' (1834); 'Richard von St. Victor und Johannes Ruysbroek' (1838); 'Dogmengeschichte' (1839).

**ENGELHARDT, Moritz von**, Russian naturalist: b. Esthonia, 1779; d. 1842. He received his education at Leipzig and Göttingen and the Freiberg mining school. He made a tour of Europe with Karl von Raumer and in 1811 visited the Crimea and Caucasus with von Parrot, and seven years later he traveled

through Finland. He taught mineralogy at Dorpat in 1820-30, and thereafter traveled and explored Russia, discovering vast deposits of gold, platinum, etc., detailed in his reports, which were issued at Riga in 1830. His principal works are 'Geognostischer Umriss von Finland' (1821); and, with von Raumer, 'Geognostische Versuche' (1816) and 'Geognostische Umrisse' (1817).

**ENGELHARDT, Vassili Pavlovich**, BARON, Russian astronomer: b. Kustovitchi, Grodno, 1828. He received his education in Saint Petersburg, entered the government employ in 1847 and remained in its service for six years. He built an astronomical observatory in Dresden in 1872. He also gave valuable astronomical instruments to the University of Kazan and erected buildings there to house them. His published works include 'Observations astronomiques faites à Dresde' (3 vols., 1886, 1890, 1895).

**ENGELHARDT, Zephyrin** (CHARLES ANTHONY), American writer and missionary: b. Bilshausen, Hanover, Germany, 13 Nov. 1851. He came to the United States in 1852, was educated in the parish schools and Saint Francis Seraph College, Cincinnati, Ohio. In 1872 he entered the Franciscan order, was ordained to the priesthood in 1878 and in 1878-80 was teacher at Saint Joseph's College, Cleveland, Ohio. From 1880 to 1885 he was missionary to the Menominee Indians in Wisconsin and from 1885 to 1887 was stationed at Superior City, Wis. He was vice-commissary for the Holy Land and editor of the *Weekly Pilgrim of Palestine* at New York in 1887-88 and for the ensuing two years was missionary in Mendocino County, Cal. From 1890 to 1894 he was stationed at Saint Joseph's Monastery, Cleveland, and from 1894 to 1900 was superior of the missions of his order in northern Michigan and of the Indian Boarding School, Harbor Springs, Mich. In 1901 he was stationed in California. In 1895 he founded and for five years edited the *Anishinabe Enamiad*, a periodical in the Ottawa-Chippewa language. He is a member of the Texas Historical Association and of the National Geographical Society and has published 'Kachkenohamatwon Kesekoch' (1882); 'Kateshim' (1883); 'The Franciscans in California' (1897); 'Missions and Missionaries of California' (5 vols., 1908-16); 'The Holy Man of Santa Clara, or Life of Father Magin Catala' (1909). He is a contributor to *Katholische Missionen, California Volksfreund, Sankt Josephsblatt*. He writes in German under the *nom-de-plume* of 'Der Bergmann' and in English of 'Esperanza.'

**ENGELMANN, George**, American botanist: b. Frankfort-on-the-Main, 2 Feb. 1809; d. Saint Louis, Mo., 4 Feb. 1884. He studied medicine at the universities of Heidelberg, Berlin and Würzburg, receiving the degree of M.D. from the last-named institution in 1831. The first half of 1832 he spent in study at Paris where he met Braun and Agassiz. In September 1832 he sailed for the United States where relatives of his had bought some land in the Mississippi Valley. In 1835 he began the practice of medicine at Saint Louis, Mo. Although he was highly successful in the practice of his profession, he had, even during his student days, become deeply interested in botany. This in-

terest grew gradually until almost all his leisure hours were occupied with scientific investigations, chiefly in relation to botany, although some of them were devoted to meteorology. As his success in his profession increased he found it possible at times to take protracted vacations, some of which he spent abroad and all of which he devoted to botanical investigations. The results of these were some 100 papers published at various times in different scientific journals, especially in the transactions of the Saint Louis Academy of Science which were examples of the most painstaking and thoroughgoing scholarship. He soon was recognized as an authority on the botany of the North American continent. The most important of his papers were on *Cuscutinae*, *Cactea*, *Conifera*, American oaks and grape vines. They together with all his other writings, hardly less important, have been collected and published, illustrated by many plates, as 'The Botanical Works of the Late George Engelmann' (ed. by W. Trelease and Asa Gray, Cambridge, Mass., 1887). This publication also contains an exhaustive biographical sketch. He was the first president of the Saint Louis Academy of Science and an active or corresponding member of many learned societies. His extensive botanical collection is in the Shaw Botanical Garden, Saint Louis, Mo.

**ENGELMANN, Johannes**, Russian jurist: b. Mitau, Courland, 7 July 1832. Educated at the University of Saint Petersburg he became professor of Russian law at Dorpat 1860, retaining the chair for 39 years, and delivering his lectures in Russian instead of German after 1887. These lectures covered a wide field and contributed greatly to the advancement of the science of jurisprudence in Russia. Among his works are 'Die Verjährung nach russischem Privatrecht' (1867; in Russian, 1868); 'Die Zwangsvollstreckung auswärtiger richterlicher Urteile in Russland' (1884); and 'Das Staatsrecht Russlands' (1888).

**ENGELS, Friedrich**, German Socialist: b. Barmen, Prussia, 28 Nov. 1820; d. London, 5 Aug. 1895. The son of a German manufacturer he spent two years in Manchester, England, 1842-44, and took part in the revolutionary movement in Baden in 1848. He returned to Manchester in 1850, and was partner in a manufacturing business from 1860-69, after which he lived mainly in London. He was an intimate friend of Karl Marx (q.v.), and his most efficient helper in the work of organizing the International Socialist movement. In 1870 Engels was corresponding secretary of the International Workingmen's Society for Belgium, Italy and Spain. With Marx he wrote the 'Communist Manifesto' (1847); he also wrote 'The Working Class in England in 1844' (new ed., 1892); 'The Origin of the Family'; 'The Development of Socialism from Utopia to Science' (1894, a part of a large work left unfinished); and edited Marx's 'Capital.' Consult Simons, 'Friedrich Engel: his Life, his Work, his Writings' (1885), a translation from Tautsky's German text; Sombart's biography (1895); and Dawson, 'German Socialism' (1899).

**ENGERTH, eng'ert, Eduard von**, Austrian painter: b. Pless, Silesia, 13 May 1818; d. 1897. He was a pupil of the Vienna Academy, taking the gold medal there in 1845. He be-

came director of the Prague Academy 1854 and in 1855 professor at the Vienna Academy. He was appointed director of the Belvedere Gallery 1871 and director of the Academy 1874. He was made commander of the order of Francis Joseph 1867. Among his works are 'Haman and Esther'; 'Ladislaus and Akus' (1844); 'Coronation of Rudolph I'; 'Joseph Explaining the Dream' (1845); 'Seizure of King Manfred's Family' (1853), a masterpiece in the Vienna Museum; 'Victory of Prince Eugene at Zenta' (1865); 'Marriage of Figaro'; 'Fable of Orpheus' (1868); 'Coronation of Francis Joseph as King of Hungary' (1870); 'Death of Eurydice' (1877). Engerth frescoed the church at Alt Lerchenfeld after the cartoons of Führich, painted numerous portraits and decorated the new Vienna Opera House.

**ENGERTH, Wilhelm**, BARON, Austrian engineer: b. Pless, Prussian Silesia, 1814; d. 1884. He received his education in architecture at the Polytechnic Institute and the Academy of Arts, Vienna. He became professor of mechanical engineering at Gratz in 1844. He is known internationally as the inventor of the "Engerth system" for freight locomotives, which was generally adopted throughout Europe. He also designed and constructed a river gate near Nussdorf to prevent ice from entering the Danube Canal, which previously was the cause of annual inundations. In 1873 he was supervising architect of the Vienna Exposition buildings and had complete charge of the engineering department at the exposition.

**ENGHIEN, äng-gän, Louis Antoine Henri de Bourbon**, DUKE OF, French prince: b. Chantilly, 2 Aug. 1772; d. Vincennes, France, 21 March 1804. He was the only son of Louis Henri Joseph Condé, Duke of Bourbon. From 1796 to 1799 he commanded with distinguished merit the vanguard of Condé's army, which was disbanded at the Peace of Lunéville (1801). He then married and took up his residence at Etenheim, in Baden. He was generally looked upon as the leader of the *émigrés*, and was suspected by the Bonapartists of being privy to the attempt of Cadoudal to assassinate the First Consul in 1804. The spies of Napoleon reported that Enghien was often absent for 10 or 12 days together from Etenheim, and it was believed that on some of these occasions he had secretly visited Paris. Napoleon therefore invaded the neutral duchy of Baden and the Duke of Enghien was seized 15 March 1804, conducted to Strassburg, and thence to the fortress of Vincennes, where he arrived on the evening of the 20th. That same night a court-martial was assembled; his innocence being established, the ground of accusation was changed into that of compassing a new coalition against France, of which he was adjudged guilty. He requested an interview with Bonaparte, which was refused, and he was immediately led out to execution. He was shot between four and five o'clock in the morning in the ditch outside the walls, and his body was thrown, dressed as it was, into a grave dug, it is said, the day before. His execution was followed by an indignant protest and the rupture of diplomatic relations with Russia; but of the deed Napoleon never repented. He was the last representative of the house of Condé. Consult Dupin, 'Pièces judiciaires' (Paris 1823), and 'Mémoires historiques sur la

catastrophe du Duc d'Enghien' (Paris 1834); Fay, 'The Execution of the Duc D'Enghien' (in the *American Historical Review*, New York 1899); Welschinger, 'Le Duc d'Enghien' (Paris 1888).

**ENGINE.** A motor or prime mover which is capable of utilizing natural forces, such as the pressure of steam or the expansion of a gas, and converting those forces into mechanical energy in the form of motion, which may be employed for doing mechanical work, thus distinguishing it from a "machine," which can receive motion only from a motor or engine external to itself.

The term engine was originally used in the sense of a machine, a usage which survives in rose-engine and cotton-gin (gin being simply a short form for engine). The first textile machines were called engines, and we still speak of engines of war. But when steam engine became familiarly shortened to engine, the term was confusing, and gradually machine was substituted for the word engine in nearly all uses except for generation of power.

All heat engines act through the medium of a working substance which absorbs heat, converts a portion of that heat into mechanical energy, which is represented by the work performed by the engine, and rejects the remaining portion of the heat, still in the form of heat. The working substance may be a gas, a liquid or a solid. The various successful forms of heat engines may be conveniently grouped into three general classes—steam engines, gas and oil engines, turbines and rotary engines.

**Steam Engines.**—In ordinary forms of steam engines the working substance is saturated steam, a fluid consisting of a mixture of water and steam in varying proportions, the expansive energy of which is utilized to drive or impart motion to a piston working within a cylinder.

**Miscellaneous Engines.**—Many engines are named from some distinctive feature of their mechanism or a peculiarity of construction. Hence there is the automatic engine, one that is self-regulating, requiring little attention. In a stationary engine this would mean one that regulated its own speed or point of cut-off; in an automobile engine it would mean one that would run without attention, as long as the gasoline feed, carburetor, spark-plug, etc., were in order. A cut-off engine is one in which the steam or motive fluid is cut off before the end of the stroke. A quadrant engine is one having a piston that moves in a quadrangular chamber. A reciprocating engine is the most ordinary type, in which the piston moves back and forth. A direct-connected engine is one that has the crank-shaft extended to form the main shaft of a dynamo. A multi-cylinder engine is one having several cylinders operating on the same shaft, as a 6- or 8-cylinder automobile engine. A self-contained engine is one in which the engine and boiler are both housed in one framework. A screw or propeller engine is a marine engine for driving a screw-propeller. A series-expansion engine is one having several cylinders in which the steam or motive fluid is successively expanded. A twin cylinder engine is one having two cylinders formed in one casting or "*en bloc*."

**High-Speed Engine.**—One in which the piston speed is rapid, according to some authorities exceeding 900 feet per minute. It possesses the advantages of small dimensions and small weight for a given power, and on account of the frequency of its strokes is capable of meeting variations in load more quickly than a low-speed engine. Its disadvantages consist in the greater waste of steam, the greater wear, increased danger of heating and higher cost of construction and operation.

**Low-Speed Engine.**—One in which the piston speed is slow, according to some authorities, less than 600 feet per minute.

**Single-Acting Engine.**—One in which the pressure of the steam is exerted only on one side of the piston, which is forced back again by the pressure of the atmosphere on the other side against the vacuum produced by the condensation of the spent steam. They were formerly used chiefly for pumping purposes, and in connection with steam hammers, but are now practically out of date.

**Double-Acting Engine.**—One in which the steam in the cylinder is exhausted into the piston, either against the pressure of the air, or against the vacuum of the condenser. Originally, all engines were made single-acting, but nearly all modern steam engines are double-acting.

**Direct-Acting Engine.**—One in which the action of the piston is transmitted directly to the crank-shaft. Nearly all engines are of this type.

**Indirect-Acting Engine.**—One in which the motion of the piston is communicated to the crank-shaft by means of intermediate levers. In the beam-engine, the connection between the piston and the connecting rods consists of a beam, the oscillating point of which is placed midway between the two rods. They are chiefly employed for pumping purposes and for driving paddle-wheel steamers. Other than in this limited field, they are becoming obsolete.

**Expansive Working Engine.**—An engine is worked expansively when the steam, instead of being admitted at full pressure into the cylinder until the termination of the stroke, is cut off at some fractional part of the stroke and thus caused to do work simply by its own expansion. The steam may be expanded in one or more cylinders. The amount of steam consumed is low as compared to the amount of work done. It is universally used where circumstances will permit, on account of its greater economy as compared with the engines of the non-expansive working type.

**Non-expansive Working Engine.**—An engine in which the steam is allowed to enter the cylinder at boiler pressure and is maintained at that pressure behind the piston during the whole of the stroke. The amount of steam consumed is disproportionately high as compared to the work done.

**Condensing Engine** (called also low-pressure or vacuum engine).—One in which the spent steam in the cylinder is exhausted into a vacuum and condensed into water, thus obliterating the back pressure of the atmosphere and consequently effecting a gain of pressure equivalent to 14.7 pounds per square inch in the effective working pressure of the steam.

**Non-condensing Engine** (called also high-

pressure engine).—One in which the spent steam in the cylinder is exhausted into the air at atmospheric pressure, thus entailing the work of forcing the piston against a back pressure of 14.7 pounds per square inch, at the expense of the effective working pressure of the steam. This disadvantage is offset by using steam at higher pressures.

**Simple Engine.**—One in which the steam after having forced the piston through its stroke is exhausted into the air or into a vacuum or condenser.

**Compound Engine.**—An engine with two or more cylinders in which the steam after having expanded and performed its work in one cylinder passes into the next cylinder, of larger size, and continues to expand and perform work. The different types of compound engines are distinguished as "series-expansion" engines or by the number of cylinders employed for the expansive working of the steam, and are designated as the two-cylinder compound engine, the three-cylinder or triple-expansion engine and the four-cylinder or quadruple-expansion engine. The cylinders are usually arranged side by side or parallel with each other. Sometimes, as in the case of the "tandem-compound," they are placed in line one behind the other, and also vertically one above the other as in the case of the "steep-compound." In a "cross-compound" the cylinders are placed side by side and parallel to each other, but sufficiently far apart to allow space for a fly-wheel between them. Up to the present time the quadruple-expansion engine appears to be the limit beyond which the numbers of expansions have not been carried with success. The great practical advantage of the multiple-expansion engines lies in their high steam economy.

**Air (or Hot Air) Engine.**—An engine in which the working fluid is air expanded by heat. It is only of experimental interest.

**Horizontal Engine.**—One in which the axis of the cylinder and piston rod is horizontal.

**Vertical Engine.**—One in which the axis of the cylinder and piston rod is vertical. Vertical engines are made in a great variety of forms and are usually arranged with the cylinders uppermost. Very few of them are constructed with the cylinders lowermost and those are only of the smallest sizes. The principal advantages of the vertical engine consist in the small space required for their foundations and the uniformity of wear on the cylinders, pistons and rods. The type includes many forms of steam hammers, launch engines, screw engines and inverted cylinder engines.

**Inverted Cylinder Engine.**—A vertical engine, in which the cylinder is inverted or placed above the piston rod, connecting rod and crank-shaft. It is typical of the marine engines employed to drive screw propellers.

**Inclined Engine or Inclined Cylinder Engine.**—A form of marine engine in which the cylinders are inclined toward each other at an angle of about 120 degrees and make a triangle with the base. They are connected by cranks to a common crank-shaft.

**Beam Engine.**—An indirect-acting engine in which the piston rod is connected to the connecting rods by means of a lever in the form of a beam. It is more fully described under the term Indirect-Acting Engine.

**Oscillating Engine.**—A marine engine of the direct-acting type, in which the cylinders are suspended upon hollow trunnions and oscillate thereon, thus allowing the motion of the piston rods to accommodate itself to that of the crank at all parts of the revolution. It occupies but little space and is peculiarly adapted for paddle-wheel steamers. It survives mainly in toy engines because of its simple construction.

**Trunk Engine.**—An engine having a large hollow piston open at one end and called a trunk. The connecting rod goes right into the open end of this trunk-piston and is attached directly to the piston-head, so that there is no piston rod. It is used in some forms of gas engines and toy engines.

**Corliss Engine.**—A very economical type of engine, in which the valves are controlled automatically from the governor and the steam supply proportioned to the requirements of the engine at each moment during its working stroke. The valve forms a segment of a circle and turns through an arc of a circle and alternately covers and uncovers the steam port. It is operated by a rod from a wrist plate, but is disconnected at every stroke of the engine and the supply valve closed instantaneously by means of a dash-pot.

**Cornish Engine.**—A standard type of pumping engine, originally of the single-acting type. At the present time it appears in two forms—the beam engine and the direct-acting engine. The valves of a Cornish engine are operated by a special device called a cataract, consisting of a weighted piston which works in a cylinder provided with a large inlet valve and a small discharge valve. The working stroke of the pump lifts the weighted piston and draws the water into the cylinder through the former, and the return stroke discharges it through the latter and at the same time actuates the valves of the steam cylinder of the pump so as to cause another working stroke.

**Marine Engine.**—Any form of engine used for propelling a vessel. They are usually of the compound or multiple-expansion type.

**Stationary Engine.**—An engine on fixed foundations, as distinguished from the locomotive, portable and marine engines.

**Locomotive Engine.**—A high pressure steam engine and multitubular boiler complete, mounted on a carriage and provided with suitable wheels to enable it to draw loaded cars upon a permanent way or railway track. See LOCOMOTIVE.

**Portable Engine.**—A small engine of the locomotive type, mounted on a carriage which permits of its being moved from place to place for use in connection with work of a temporary character. Portable engines are extensively used for agricultural purposes and for general traction purposes on ordinary highways.

**Gas and Oil Engines.**—These classes of heat engines are commonly designated as internal-combustion engines. See INTERNAL COMBUSTION ENGINE and DIESEL ENGINE.

**The Slide-Valve.**—The introduction of the slide-valve for operating the ports of a steam engine marked a distinct advance in economy, because it can be made at exactly the right time and also because it admits the hot steam to the cylinder through a port which has just been

cooled by the exhaust. As ordinarily constructed the slide-valve is a sliding D-shaped piece in the steam-chest, moving back and forth over the three ports—the two end-ports of the cylinder and the exhaust port in the centre—and permitting the steam to pass alternately to either end of the cylinder to push the piston and opening the exhaust for the release of the used steam. There are "laps" at the end of the D whose length determines the instant at which the ports shall begin to open. These laps are known as outside or steam-lap, and inside or exhaust-lap. The slide-valve has also been developed for automobile use in the Knight type of engine.

**Superheating.**—Originally, saturated steam was the only sort employed in steam engines, but as multiple-expansion developed and higher pressures were carried in boilers the use of superheated or dry steam at as high as 500° C. was tried, and it was demonstrated that the hotter the steam was the more it expanded and the greater the power to be got out of it. Superheating began experimentally about 1895 and was operated in connection with an economizer. This is a mechanism for utilizing the waste heat and turning it into the feed-water, so that hot water, close to the boiling point, can be supplied to the boiler. Engines using superheated steam have been operated with as little as 1.3 pounds of coal per indicated horse power. See LOCOMOTIVE.

**Steam Turbines** comprise a class of heat engines in which the kinetic energy of expanding steam is utilized to drive a wheel and thus convert the natural heat energy of steam directly into mechanical energy in the form of rotary motion. The principal forms are the Parsons, De Laval, Seger and Curtis turbines, and their first field of application and development was in the marine service. Noteworthy examples of their application are the *Lusitania* and *Mauretania* ocean steamships and many of the modern "dreadnaught" type of battleships. They are now coming into use in large lighting stations and mammoth manufacturing plants. See TURBINE.

**Hydraulic Engines.**—Mechanical power is obtained from flowing water by its weight, pressure or impact, utilized in various forms of water wheels, turbines, hydraulic rams and water-pressure engines. In the water-pressure engine the pressure of the water only is utilized to drive a piston in a cylinder. In some forms the action of the piston is reciprocating and in others rotary. In all of them the actual amount of pressure expended is only that which is needed to impart motion to the fluid to follow the piston and escape from the cylinder, and, therefore, the greatest efficiency is obtained by making the piston as small as practicable and using a large pressure. The majority of them are of the reciprocating, low-speed type, and are particularly useful as secondary motors for operating the opening machinery of various forms of swing, draw and lifting or rolling bridges, and in connection with cranes and various forms of hydraulic lifts.

For further detailed information relative to the construction, operation and application of the various forms of engines, consult the articles under the titles AUTOMOBILE; AEROPLANE; INTERNAL COMBUSTION ENGINE; LOCOMOTIVES; MOTOR; PUMPS AND PUMPING MACHINERY; RO-

TARY STEAM ENGINE; TRACTION ENGINES; TURBINE; WATER MOTOR; WATER WHEEL.

CHARLES H. COCHRANE,

*Author of 'Modern Industrial Progress.'*

**ENGINE, Testing of.** Engines are tested in order to determine the economy with which they produce a given amount of power. The economy of steam engines, as usually determined, relates to the weight of steam consumed, or to the quantity of coal used in making the steam, or to the number of heat units supplied; while in the case of an internal combustion engine, it relates to the amount of gas, gasoline, oil, alcohol or other fuel burned. Also, if the latter operate on producer gas, the determination of economy involves the amount of coal burned in the gas producer.

Factory tests are generally limited to the performance of individual engines, to determine the set of the governor relative to the proper speed and to ascertain if the valves are set and operate properly. In the case of gas engines, the factory test is extended to cover the correct timing of the igniter and to determine the correct compression.

In its broadest sense, however, testing is a form of scientific investigation conducted for the purpose of securing practical results which are very important not only to the manufacturer, but also to the owner of the engine who has to pay the expense of its operation and to those who require information showing the capabilities of the machines for the purpose of advertising and trade.

As an engine test involves the determination of two elementary quantities—(1) the amount of fuel consumed, and (2) the amount of power developed—it is necessary that these two factors should be represented by units of measurement which are susceptible of universal application.

**Standard Unit of Fuel.**—The most satisfactory unit for expressions of economy based on the amount of fuel consumed is the British Thermal Unit (B.T.U.), which is the quantity of heat required to raise one pound of water 1° F. at or about 39.1° F. According to Joule, it is equivalent to 778 foot-pounds of mechanical energy.

A convenient and useful subsidiary standard is that based on a "standard coal" unit, the term "standard coal" defining a coal which imparts to steam 10,000 B.T.U.'s for each pound of dry coal consumed. It is a coal which has a calorific value of 12,500 B.T.U.'s, equivalent to an efficiency of 80 per cent when used in a "standard boiler."

**Standard Unit of Power.**—The unit of mechanical power which most satisfactorily expresses the power developed by an engine is the "horse power," which represents an energy of 33,000 foot-pounds per minute, equivalent to 2,545 B.T.U.'s per hour.

**Standard of Engine Economy.**—Employing the given standard units of fuel and power, the expressions of engine economy which are best adapted to meet all conditions of service and for all classes of heat engine are those represented by the "indicated" horse power based on the number of B.T.U.'s consumed per hour.

Such an expression is commonly called a horse power hour and represents a heat energy of 1,980,000 foot-pounds converted into mechanical power or work by the consumption of 2,545 B.T.U.'s per hour.

**Rules for Conducting a Test.**—All tests should be conducted systematically under a set of standard rules, clearly defining the character of the data to be obtained and the methods which should be employed for their determination. A set of such rules may be briefly defined as follows:

1. *Object of the test.*—At the beginning, the specific object of the test should be ascertained. It may relate to the determination of highest economy obtainable; the economy under ordinary working conditions and the existing defects; the performance under special conditions; the effect of changes in existing conditions; or the fulfilment of a contract guarantee; and the preparations for the test should be made accordingly. These preparations will necessarily depend largely upon the good sense, judgment and ingenuity of the engineer making the test.

2. *Condition of the Engine.*—The engine should be carefully examined and its general condition noted, especially any points of design, construction or operation which bear upon the object of the test. Special examination should be made of all valves, by inspecting their seats and bearing surfaces and great care taken to ascertain, in the case of a gas engine, that the piston rings work freely in their grooves and are perfectly gas-tight.

3. *Dimensions.*—The cylinder dimensions should be taken whether they are already known or not, the measurements being made when they are hot and in working order. When practicable, the clearance volume or compression space of the cylinder should be measured by filling it with water previously measured, the proper correction being made for temperature.

4. *Fuel.*—When the test involves the complete plant—in the case of a steam engine including the boilers, and in the case of a gas engine including the gas producer plant—the class, name of coal mine, size, moisture, should be stated in the report—and the quality of the coal used should be of some recognized standard. This is desirable for purposes of comparison. In the case of an internal combustion engine, if the test is made to determine the maximum efficiency, the gas, oil, or other fuel used, should be the best obtainable, or one that possesses the highest calorific value.

5. *Measurement of Fuel.*—The methods of determining the amount of fuel consumed depend upon the character of the fuel used. If it be coal furnished to the furnace of a boiler, or to a gas producer, the amount consumed during a period not less than 24 hours should be carefully measured by weight. If it be oil, gasoline, distillate, alcohol, etc., it can be drawn from a tank, which can be refilled to the original level at the end of the test, and the amount required for this purpose weighed; or in the case of a small engine, it can be drawn from a properly calibrated vertical pipe. When gas is used, it should be measured by a suitable gas metre and gas bags should be placed between the metre and the engine to keep the pressure as constant as possible. The pressure and temperature of the gas and the barometric pressure and temperature of the air should be measured and in determining the quantity of the gas supplied, as given by the reading of the metre, the temperature and pressure of the gas should be taken into account.

6. *Measurement of Heat Units Consumed.*—The number of heat units consumed by the engine can be found by multiplying the number of pounds of coal or oil, or the cubic feet of gas supplied, by the total heat of combustion of the fuel as determined by a calorimeter, or from the results of a chemical analysis. In determining the total heat of combustion, usually no deduction is made for the latent heat of the vapor of water in the products of combustion, therefore, for purposes of comparison, care should be taken to state whether the higher or the lower value has been used in the determination.

The Mahler calorimeter is a type much used for determining the heat of combustion of solid fuels and oils and the Junker calorimeter for gases.

7. *Instruments and Their Calibration.*—All instruments and apparatus used in the tests should be calibrated and their accuracy verified by comparison with recognized standards. All such as are liable to undergo changes, or become broken during the progress of a test, especially gauges, indicator springs and thermometers, should be calibrated both before and after the test.

*Gauges.*—For measuring pressures above that of the atmosphere, the most convenient and reliable standard is the dead-weight testing apparatus, consisting of a cylinder having a close-fitting vertical piston working in oil or glycerine, by the medium of which the pressure is transmitted to the gauge. The piston is surmounted by a circular stand on which weights may be placed so as to secure any desired pressure. The total weight, in pounds, on the piston, divided by the area of the piston, in square inches, gives the pressure in pounds per square inch.

The mercury column is another reliable standard of comparison for pressures, but when it is used care should be taken to see that it is properly graduated with reference to the ever varying zero point; that the mercury is pure and that the proper correction is made for any difference of temperature that may exist at the time of using and the temperature at which the instrument was graduated.

For pressures below that of the atmosphere, the use of an air pump or some other means of producing a vacuum is required. The apparatus must be referred to a mercury gauge, which may consist of a U-shaped tube about 30 inches in length, with both arms properly filled with mercury.

*Thermometers.*—Standard thermometers are those which read 212° F. in steam escaping from boiling water at the normal barometric pressure of the atmosphere (29.92 inches) when the whole stem up to the 212° point is surrounded by the steam; and which read 32° F. in melting ice, when the stem is completely immersed to the 32° point; and which are calibrated for points between and beyond these two points of reference.

For temperatures between 212° and 400° F., the thermometers should be compared with the temperatures given in Regnault's Steam Tables, by placing it in a mercury well surrounded by saturated steam under sufficient pressure to give the desired temperature.

For higher temperatures, such as those occurring in gas-engine practice, which often

exceed 2,000° F., some form of pyrometer or calorimeter should be used. That of Le Chatelier, which makes use of the thermocouple, has been successfully used for accurately measuring temperatures over 2,500° F.

*Indicator Springs.*—For gas-engine indicating, the indicator springs used should be much stiffer and stronger than those used for steam-engine work, so as to enable them to withstand the higher and more suddenly developed pressure. When indicator springs are calibrated, the temperature of the indicator should be as nearly as possible the same as that which exists during the test. An indicator may be conveniently heated by subjecting it to steam pressure immediately before calibration and the actual work of calibration then performed by the use of compressed air or compressed carbonic acid gas. The calibration may be made under a constant pressure, or more satisfactorily by covering the whole range of pressures through which the indicator acts, by gradually increasing the pressure from the lowest to the highest point, and then by gradually reducing it from the highest to the lowest point, and a mean of the results taken for at least five points—two for the pressures corresponding to the maximum and minimum pressures and three for equally distant intermediate points. These values should be compared with a dead-weight testing apparatus, a mercury column, or a steam gauge, compared with either of the two first-named standards, and the correct scale of the spring used for calculating the mean effective pressure from the indicator diagrams taken during the test, should be the average based on this calibration.

*Gas Meters.*—A meter used for measuring the gas supplied to a gas engine should be calibrated by comparing its readings with the displacement of a gasometer of known volume; with a standard gas meter of known error; or by passing air through the meter from a tank containing air under pressure. In the latter case, the pressure and temperature of the air in the tank, both at the tank and the meter, should be observed at uniform intervals of time during the work of calibration; and the amount of air passing through the meter calculated from the volume of the tank and the observed temperatures and pressures.

The volume of the gas thus ascertained should be reduced to the equivalent volume at a given temperature and atmospheric pressure, corrected for the effect of moisture in the gas, which is usually at or near the point of saturation. For gas-engine work, a convenient standard is the equivalent volume of the gas when saturated with moisture at normal atmospheric pressure at a temperature of 60° F. A volume of moist gas at any other temperature may be reduced to this standard by being multiplied by the factor

$$\frac{459.4+60}{459.4+t} \times \frac{b-(29.92-s)}{29.4},$$

in which  $b$  represents the reading of the barometer in inches at 32° F.;  $t$ , the temperature of the gas at the meter in degrees F.; and  $s$ , the vacuum in inches of mercury corresponding to the temperature of  $t$  given in the steam tables.

8. *Duration of a Test.*—The length of time devoted to a test will depend largely upon its

character and the purpose for which it is made. For determining the working economy, the time allowed should be equal to the number of hours per day during which the engine is really operated. In the case of a gas engine using producer gas, the time should be sufficient to determine the amount of coal used in the gas producer. It should never be less than 24 hours, and usually it should extend over several days.

9. *Commencement of a Test.*—If the test is to determine the performance of an engine under working conditions, it should begin at the time the engine is started, and the observations continued until it shuts down for the day. If the test is for determining the maximum economy of the engine, at first it should be run a sufficient length of time to make all conditions normal and constant, then the observations may be commenced and continued for the allotted time.

10. *Measurement of Water.*—In the case of a steam engine this relates to the feed water or steam consumption. The usual method is to measure all the feed water supplied to the boilers, and deduct therefrom all the water discharged by separators and drips, and the water and steam lost by leakage from the boiler and its main and branch pipe connections with the engine. Where the engine exhausts into a surface condenser, the steam consumption can be measured by measuring the quantity of water discharged by the air pump and adding thereto the steam used by jackets, reheaters and auxiliaries as determined independently. In measuring the water, it should be carried through a tank resting on the platform of a suitably arranged weighing scales, and the water subsequently emptied into a reservoir beneath, from which the pump is supplied.

For measuring small quantities of water, about 6,000 pounds per hour, the most convenient apparatus consists of a small hogshead connected to the suction pipe of the pump or injector and an ordinary oil barrel placed on a platform scale. The barrel is filled by means of a cold-water pipe leading from the source of supply. For pressure not less than 25 pounds per square inch, this pipe should have an internal diameter of one and one-half inches. The outlet valve of the barrel is attached to the side near the bottom and should be at least two and one-half inches in diameter, so as to permit of quick emptying.

Where larger quantities of water have to be measured, the barrel can be replaced by a hogshead and two hogsheads can be joined together for the lower reservoir. With this arrangement, when the weighing hogshead is supplied through a two and one-half inch valve under 25 pounds of pressure and emptied through a five-inch valve, the capacity attained is 15,000 pounds of water per hour.

For the measurement of very large quantities, or in some cases, very small quantities, the orifice method gives the most satisfactory results, and when applied, the average head of water on the orifice must be ascertained and the discharge of the orifice should be calibrated under the conditions of use.

In the case of an internal combustion engine, the measurements of water relate to that supplied to the water-jacket provided for cooling the temperature of the cylinder. The measure-



ments may be made by the methods already described, but care should be taken, in cases where the temperature exceeds 212° F., first to cool the water by discharging it into a tank of cold water previously weighed, or by passing it through a coil of pipe immersed in running cold water, so as to prevent the loss of evaporation which takes place when hot water is discharged into the open air.

11. *Determination of Speed.*—The speed of the engine, or the number of revolutions of the crank shaft per minute, can be determined by counting the number of revolutions in one minute with the eye fixed on the second hand of a timepiece, or by the use of some form of mechanical counter such as a tachometer, or continuous recording engine register. The use of such instruments is imperative when the speed exceeds 250 revolutions per minute.

In the case of internal combustion engines governed by the hit-or-miss method, the number of explosions per minute should be ascertained, when the engine is running under nearly maximum load, by counting the number of times the action of the governor causes a miss in the explosions.

The determination of variation of speed during a single revolution on the effect of fluctuations due to sudden changes of load should be made especially in the case of engines employed to drive electric generators used for lighting purposes.

12. *Indicator Diagrams.*—From the indicator diagrams taken during the test for the computation of the mean effective pressure, etc., sample diagrams nearest to the mean should be appended to the report.

The mean effective pressure (M.E.P.) is obtained as follows: Measure the diagram with a planimeter and divide the area, in square inches, thus obtained by the length of the diagram in inches to obtain the mean height or mean ordinate of the diagram. Multiply the mean ordinate by the scale of the indicator spring and the product will be the mean effective pressure desired. In the absence of a planimeter, the diagram can be divided by 10 ordinates and their mean length taken for that of the mean ordinate. If the indicator is specially designed for indicating internal combustion engines, the mean ordinate should be multiplied by twice the scale of the spring, unless the scale has been expressly marked for the reduced piston.

In the case of internal combustion engines, when indicator diagrams are not obtainable and the compression pressure is known, the mean effective pressure may be determined approximately as follows: For example, in gas engines the compression pressure ranges from 70 to 90 pounds per square inch, and the maximum pressure developed by the explosions is about 3.5 times the compression pressure. Therefore, if  $p$  represents the compression pressure, then for compressions of 100 pounds per square inch or less,  $M.E.P. = 2p - 0.01p^2$ ; thus, if  $p = 70$  pounds per square inch,  $M.E.P. = 140 - 49 = 91$  pounds per square inch.

In the case of a steam engine, the steam accounted for by the indicator diagram may be calculated by means of the formula

$$13750$$

$$M = M.E.P. \cdot (C + E) \cdot W_c - (H + E) \cdot W_h,$$

which will give the weight in pounds per indi-

cated horse power per hour. M.E.P. represents the mean effective pressure, which in the case of a multiple-expansion engine is the combined mean effective pressure referred to the cylinder in question. For example: In the case of a compound engine, the combined mean effective pressure for the high pressure cylinder consists of two items: (1) the mean effective pressure of the high pressure cylinder, and (2) the mean effective pressure of the low pressure cylinder multiplied by the ratio of the piston displacement of the low pressure cylinder to that of the high pressure cylinder. The sum of these two items is the combined mean effective pressure for the high pressure cylinder.

Similarly the combined mean effective pressure for the low pressure cylinder consists of (1) the mean effective pressure of the low pressure cylinder, and (2) the mean effective pressure of the high pressure cylinder divided by the ratio already stated. The sum of the two items is the combined mean effective pressure of the low pressure cylinder.

In the given formula,  $C$  represents the proportion of the piston stroke completed at points on the expansion line of the diagram near the actual cut-off or release;  $H$  the proportion of compression; and  $E$  the proportion of clearance; all of which are determinable from the indicator diagram.  $W_c$  represents the weight of one cubic foot of steam at the cut-off or release pressure; and  $W_h$  the weight of one cubic foot of steam at the compression pressure.

13. *Standards of Economy and Efficiency.*—The standard expression for engine economy, as already stated, is the hourly consumption of heat units divided by the indicated horse power or the brake horse power. The standard expression for efficiency is the thermal efficiency ratio, or the proportion which the heat equivalent of the power developed bears to the total amount of heat actually consumed, as determined by test. One horse-power-hour represents the consumption of 2,545 B.T.U.'s per hour, therefore,

$$2,545$$

B.T.U.'s per horse power per hour

expresses the thermal efficiency ratio.

In comparing the standard for internal combustion engines with that for steam engines, it must be noted that the former usually covers the losses due to combustion, but the latter does not, and therefore, in order to make a direct comparison between the two classes of engines as complete horse-power plants, the losses in generating the working agent must be considered in both cases not only on the basis of the fuel used, but on the basis of equivalent fuel used in each case. In comparing a gas engine plant using producer gas, with a steam plant, the producer should be included in the former, and then the fuel consumption, represented by the weight of coal in both cases, may be directly compared.

14. *Heat Analysis.*—For scientific purposes, a heat analysis of the indicator diagram, in the case of a steam engine, and a heat balance in the case of an internal combustion engine, should be made, showing the manner in which the total heat of combustion is expended in working the engine.

In the case of a steam engine, the analysis shows the interchange of heat from steam to

cylinder walls, etc. For example: the amount of heat supplied to the engine in a given time is represented by the number of pounds of steam supplied multiplied by the total heat of one pound of steam. A portion of this heat is used in the jacket, if one be employed, and the remainder passes through the cylinder. The heat entering the jacket is lost partly by radiation from the outside surface, and the remainder enters the walls of the cylinder and is absorbed by the steam within it. The cycle of operations within the cylinder consists of the following phases: (1) A portion of the entering heat is transferred into a small portion of the thickness of the cylinder walls, and heats them to the temperature of the entering steam. This transference of heat is more active during the period of admission and up to the point of cut-off than during any other part of the cycle. (2) Beyond the point of cut-off, the transference of heat continues until the lower pressure due to expansion causes the temperature of the steam to fall below that of the interior surfaces of the cylinder last uncovered. At this point the interchange of heat is reversed, the metal giving up heat to the steam, and causing the re-evaporation of the particles of water condensed on the surface of the cylinder walls and piston. The radiation of heat from the small thicknesses of the interior walls, which were heated during admission to the temperature of the entering steam, commences after cut-off or after the pressure begins to lower by expansion, and continues to the end of the stroke.

A portion of the heat is also expended in the performance of work, and a loss of heat is sustained by radiation from those portions of the cylinder not protected by the jacket. The amount of heat remaining after the steam has passed through these operations is that which is rejected by it through the exhaust valve to the atmosphere or to the condenser.

In the case of an internal combustion engine, the total heat of combustion expended in the working of the engine may be divided into three parts: (1) Heat converted into work and represented by indicated or brake horse power. (2) Heat carried away by the cooling water circulated through the water jacket. (3) The heat lost in the exhaust gases, and through incomplete combustion and radiation.

15. *Heat Converted into Indicated or Brake Horse Power.*—The number of foot-pounds of work done by one pound or one cubic foot of fuel divided by 778, the mechanical equivalent of one British Thermal Unit, will give the number of heat units desired.

16. *Heat Carried Away by the Jacket Water.*—This is determined by measuring the quantity of cooling water passed through the water jacket equivalent to one pound or one cubic foot of fuel consumed, and calculating the amount of heat rejected by multiplying that quantity by the difference of the temperature of the water entering and leaving the jacket.

17. *Heat Rejected in the Exhaust Gases, or Total Heat Unused.*—The sum of the heat converted into brake horse power and the heat carried away by the jacket water, subtracted from the total heat supplied, will give the total heat rejected or unused.

In order to determine the cost of each horse-

power hour in thermal units, the gas consumed and the air supplied should be reduced to the conditions of temperature and pressure corresponding to some adopted standard. This may be done as stated under gas meters in rule 7, or more conveniently by the formula

$$v = \frac{t}{p} \times \frac{v'p'}{v'}$$

in which  $v$  = volume of gas reduced to standard;  $t = 461 + 60 = 521^\circ$  F., absolute standard temperature;  $p = 29.92$  inches of mercury;  $v'$  = volume of gas registered by meter;  $p'$  = pressure of gas at meter measured by manometer in inches of water;  $t'$  = absolute temperature of gas.

Since  $t$  and  $p$  are constants

$$v = 18.00 \frac{v'p'}{v'}$$

and as  $p'$  and  $t'$  are practically constant during a given test,  $v = Ev'$ , in which

$$E = 18.00 \frac{p'}{v'}$$

and  $p'$  = height of barometer + (0.073 × reading of manometer); and  $t'$  = temperature of gas at meter + 461.

For example: Assume the heights of the barometer as 29.40 inches; the reading of the manometer as 6 inches; the temperature of the gas  $80^\circ$  F.; and the volume of the gas registered by the meter 350 cubic feet; then for determining ( $v$ ) the equivalent volume of gas for standard conditions:

$$p' = 29.40 + (0.073 \times 6) = 29.84$$

$$v' = 80 + 461 = 541;$$

$$E = \frac{18.00 \times 29.84}{541} = 0.976;$$

then  $v = 0.976 \times 350 = 341.6$  cubic feet.

The air supplied should be entered and reduced to standard conditions in the same manner.

If the rate method is employed to ascertain the amount of gas consumed, the number of cubic feet for a ten-minute interval may be found by dividing the number of cubic feet registered by one revolution of the small dial by the time in seconds elapsed at the completion of that revolution and multiplying the result by 6,000.

18. *Indicated Horse Power (I.H.P.).*—This factor is expressed by the formula—

$$I.H.P. = \frac{P \times L \times A \times N}{33,000},$$

in which  $P$  is the mean effective pressure in pounds per square inch;  $L$  the length of the piston stroke in feet;  $A$  the area of the piston in square inches; and  $N$  the number of revolutions of the engine crank shaft per minute.

$$\frac{A \times L}{33,000},$$

is constant for a given engine, and in the case of an internal combustion engine,  $N$  is the number of explosions per minute.

19. *Brake Horse Power (B.H.P.).*—When this factor is determined by the use of some form of dynamometer, such as the Prony brake, it may be readily computed from the formula—

$$B.H.P. = \frac{W \times N \times L \times C}{33,000},$$

in which  $W$  is the net weight in pounds on the scales;  $N$  the number of revolutions per minute;  $L$  the length of the lever arm from the centre of the braked wheel to the knife-edge of the

brake, or the radius of the braked wheel if a rope brake is used; and C the circumference of the braked wheel.

$$\frac{C \times L}{33,000}$$

is constant for a given Prony brake, therefore, if L be made five and one-quarter feet, this constant becomes 0.001, and gives the simple and very convenient expression—

$$\text{B.H.P.} = \frac{N \times W}{1,000}$$

20. *Total B.T.U.'s Per Hour.*—The total amount of gas consumed, in cubic feet, multiplied by its calorific value.

*B.T.U.'s Per Brake Horse Power Hour.*—The total B.T.U.'s per hour divided by the brake horse power.

*B.T.U.'s Per Indicated Horse-power Hour.*—The total B.T.U.'s per hour divided by the indicated horse power.

*Friction Horse Power.*—The difference between the indicated horse power and the brake horse power.

*Thermal Efficiency.*—The ratio of 2,545 B.T.U.'s to the B.T.U.'s per horse-power hour.

*Mechanical Efficiency.*—The ratio of the brake horse power to the indicated horse power.

WILLIAM MOREY, JR., C.E.,

*Consulting Civil and Mechanical Engineer, New York.*

**ENGINE INDUSTRY.** Notwithstanding the wonderfully rapid development of water power and of the internal combustion engine, the steam engine holds its own in the industries of the world. The total steam engine horse power used in manufacturing in the United States, which was 8,139,574 in 1900, rose to 14,199,339 in the 1910 census. Seven great industries utilize 56 per cent of the horse power employed in manufacturing in this country, and 76 per cent of the power they use is based on the steam engine. The industries meant are lumber, steel works and rolling mills, paper and pulp mills, cotton factories, blast furnaces, foundries and machine shops and grist mills. In only one of the seven—the paper and pulp industry, which requires large quantities of water for dissolving pulp—is steam power less used than water power. The fourteen million horse power quoted does not by any means represent the total employment of steam engine power in the country, but only such as the census gathers as reported by manufacturers. It does not cover steam engine power used on vessels, nor used in mines and quarries, nor its vast employment in the locomotives that do most of the haulage on the railways, nor a number of minor uses. These are reported in other ways, or escape enumeration. The best way of measuring the steam engine industry is to note that 450,000,000 long tons of coal are used in the United States every year, and it is estimated that at least 350,000,000 tons of this is consumed under boilers to make steam. Evidently while the coal holds out the steam engine is going to continue the favorite power-producer, because it can be located anywhere and its cost is moderate. Even the electric railway lines around New York city and the electric light and power companies there, base their power entirely on the steam engine.

There are no complete figures of the engine industry because it is so completely interwoven

with other activities that it cannot be separated. Thousands of machinery manufacturers build steam engines, which are part of this or that special industry, often being for their own use. The internal combustion engines alone are mixed up with 20 different industries from automobiles to blast furnaces and a vast number of engines are built direct-connected to dynamos and credited to the electrical industries. See INTERNAL COMBUSTION ENGINE; GAS ENGINE; STEAM AND STEAM ENGINES; LOCOMOTIVE; LOCOMOTIVE INDUSTRY; AUTOMOBILE ENGINE; AEROPLANE.

**ENGINE STARTERS,** or "self-starters," auxiliary devices for the purpose of starting gasoline automobiles (or other) engines without laborious method of turning the hand crank commonly provided. Self-starters operate upon either of two principles: the crank shaft is rotated by external mechanism, causing the pistons to charge the cylinders with gas to be exploded when the spark is turned on; or the injection of gas into one or more cylinders without rotation of the crank and the production of a spark in all the cylinders simultaneously so that the charged cylinder will come into action. Mechanical starters are operated by a heavy spring, by compressed air, or by electricity. They require a considerable addition to the machinery of the car as well as to its weight, especially in the case of the electric starter and add many sources of possible trouble in an already complicated machine.

The gas injector system adds simply a small hand pump at the driver's seat or on the dashboard, two strokes of which effects the charging of the cylinders; and the throwing of a switch fires the charge. In automobiles which employ acetylene gas for lighting, an attachment is furnished by which this gas may be used in priming the cylinders for starting. The acetylene mixture is claimed to be more certain of explosion than an uncompressed charge of gasoline vapor and air. Consult Cross, H. H. U., 'Electric Lighting and Starting' (London 1915); Duryea, C. E. and Homans, J. E., 'The Automobile Book' (New York 1916); Page, V. W., 'The Modern Gasoline Automobile' (New York 1912).

**ENGINEER CORPS,** a branch of the service of the United States Navy; and of those of other countries. The first step toward the organization of an engineer corps in the United States Navy was taken on 2 July 1836, when C. H. Haswell (q.v.) was appointed chief engineer of the *Fulton*; it was not, however, until 31 Aug. 1842 that Congress passed an act providing for a regular corps, under which act chief engineers were "commissioned" and assistants "warranted." On 3 March 1845 Congress passed an act whereby the power of appointing engineer officers was transferred from the Secretary of the Navy to the President "by and with the advice and consent of the Senate." With the growth of the Navy the corps gradually increased till at the time of the Civil War there were 474 regulars and 1,803 volunteers.

A course of instruction for cadet engineers was established at the Naval Academy by act of Congress 4 July 1864. The original two-year course was changed to four years in 1874 and continued in vogue till 1882, when on 5 August Congress amalgamated the cadet engineers and

midshipmen and they are now known as naval cadets. The cadets then took the usual six years' course at the Academy and upon completion of the third year of the course were divided into an Engineer Division and a Line Division in proportion to the vacancies that have occurred in the several corps during the preceding year. At the end of the six years' course appointments to fill vacancies in the Line and in the Marine Corps were made from the Line Division, and to fill vacancies in the Engineer Corps from the Engineer Division. If, after making assignments as above, there should still be vacancies in one branch and surplus graduates in the other, the vacancies in the former were filled by assignment to it of surplus graduates from the latter. This arrangement was in vogue until the Line and Engineer Corps were amalgamated under the act of 3 March 1899, at which time the Engineer Corps ceased to be a separate organization, the older officers now being required to perform engineering duties only, whereas the younger officers must pass examinations in navigation, gunnery, seamanship, etc. A grade of warrant machinists to perform watch duties was also established because of the lack of commissioned officers for this work. See NAVAL ACADEMY, UNITED STATES; UNITED STATES NAVY.

**ENGINEERING** is, in its strict sense, the art of designing, constructing, or using engines, but the word is now applied in a more extended sense, not only to that art, but to that of executing such works as are the objects of civil and military architecture, in which engines or other mechanical appliances are extensively employed. Engineering is divided into many branches, the more important being civil, mechanical, electrical, mining, military, marine and sanitary engineering.

Among the most notable of the engineering works belonging to very remote antiquity are the pyramids of Egypt. The rude stone monuments of the north, as at Stonehenge and Carnac, also testify to some engineering skill. The harbors and temples of ancient Greece are very memorable. The buildings of ancient Rome—its theatres, temples, baths and aqueducts, its roads, bridges and drainage-works—vie in extent and magnificence with the most celebrated works of modern times. From that period down to the commencement of the 18th century, the most extensive works executed were the canals, embankments and other hydraulic construction used by the Dutch for the purposes of inland navigation and to protect their low lands from the sea; the canals of North Italy; and the cathedrals and fortifications of mediæval Europe.

If the question were asked as to the characteristic feature of the modern applied science of engineering, the reply would undoubtedly be: "The wholesale manner in which work is carried on." It is not so very long ago that everything except the smallest articles and those required in great quantity were made singly, or at least in small lots; and even when standardizing and interchangeability were introduced these methods were by no means used in a way which showed a realization of their possibilities. The present tendency, on the contrary, is toward the elimination altogether of things which cannot be made wholesale; and methods which formerly applied

to firearms, sewing-machines, typewriters and the like are now in general use in the manufacture of steam engines, machine tools, electrical machinery and nearly all mechanical products.

This has been brought about by a combination of two processes: (1) the standardization of methods of manufacture; and (2) the discouragement of the demand for special articles. Formerly the customer told the manufacturer what was wanted and the latter hastened to produce it. Or the plans and specifications for a certain structure were prepared by a consulting engineer and all bidders were required to conform to these documents in the minutest details; no two such specifications being alike. At the present time the customer, knowing what he wishes to accomplish, seeks to do so as best he may by means of the standard articles in the market; or if it be a great engineering structure, the engineer specifies only the general requirements to be met, leaving each manufacturer to meet these with his own standardized product. The influence of these modifications in engineering practice extends to the manufacture and supply of materials.

The result of this concentration and standardization has been to reduce costs very materially and render possible undertakings which would otherwise be prohibitory in price. While to a certain extent it has obliterated individuality in design, it has also removed much useless repetition and has prevented needless expense in the production of rival machines, differing but slightly in design, yet requiring duplications of drawings, patterns and tools. There is little doubt that it is to this wholesale development of various departments of engineering work that the rapid extension of the share of the United States in the work of the world is largely due. See CIVIL ENGINEERING; ELECTRICAL ENGINEERING; HYDRAULIC ENGINEERING; MECHANICAL ENGINEERING; ENGINEERING, MARINE; FORTIFICATIONS; MINING ENGINEERING; NAVAL CONSTRUCTION; SANITARY ENGINEERING. Also ENGINEERING TERMS; ENGINEERING INSTRUMENTS; EDUCATION, ENGINEERING; MECHANICS.

**ENGINEERING, Electrical.** See ELECTRICAL ENGINEERING.

**ENGINEERING, Hydraulic.** See HYDRAULIC ENGINEERING.

**ENGINEERING, Marine,** is partly military and partly civil, embracing naval architecture, building and operating of ships and naval accessories. In the military sense, it comprises the construction of war vessels and the construction and placing of torpedoes, submarine mines, etc. See NAVY; NAVAL CONSTRUCTION; SUBMARINE MINES, etc.

**ENGINEERING, Mechanical.** See MECHANICAL ENGINEERING.

**ENGINEERING, Mining.** See MINING ENGINEERING.

**ENGINEERING, Sanitary.** See SANITARY ENGINEERING.

**ENGINEERING EDUCATION.** See EDUCATION, ENGINEERING.

**ENGINEERING INSTRUMENTS.** To attempt a definition of an engineering instrument is hardly practicable, as the wide range of departments into which the profession is now

divided demands so many special appliances for their requirements that no one description is possible and an extended catalogue is inadmissible within the limits of this article. The earliest known engineering instrument was the Dioptra of Hero of Alexandria, 130 B.C., although rude appliances must have been used long before that time by the ancient engineers in the construction of the public works of Chaldæa and Egypt, the ruins of which even now awaken our admiration and wonder. It was not, however, until the beginning of the 19th century that the great impulse to the construction and use of engineers' instruments was

and lightness of construction combined with great strength and an adaptability of parts for the special service required. It is not the purpose of this article to attempt a description of the various instruments used by engineers—this may be found in the article SURVEYING—but to give the reader a general idea of their construction.

The metals used in the construction of engineers' instruments are principally the alloys of copper and tin with small quantities of silver, aluminum and German silver. Great care must be constantly exercised that these substances be free from iron or other materials which would

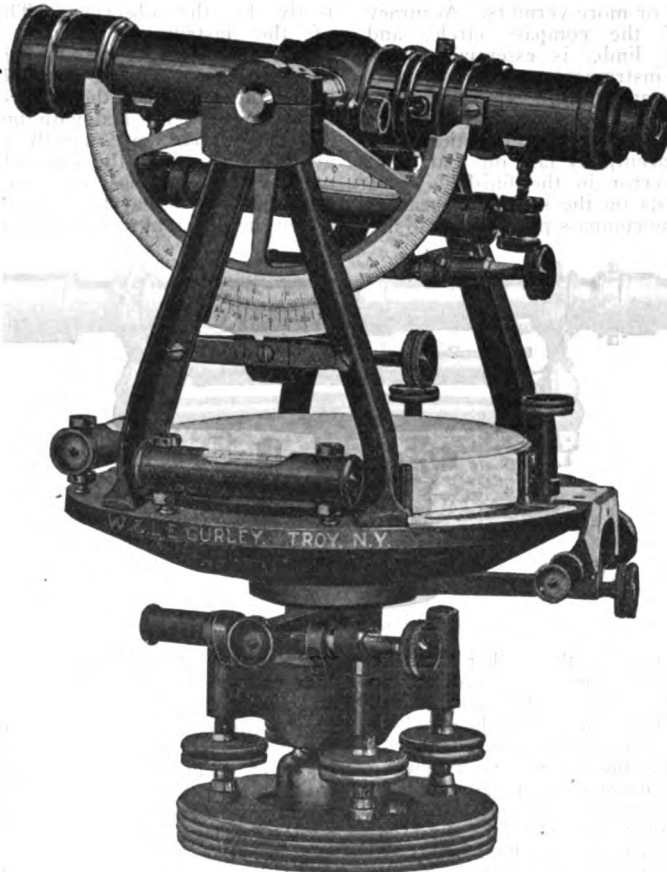

Engineer's Transit.

given by the advance of civilization and commerce incident to the application of steam as a motive power on sea and land. Since that time great advances have been made not only in the design and accuracy of engineering instruments but also in the invention of new instruments for the many purposes required by engineers in the construction of railroads, canals, bridges, harbors, etc.

The characteristics of engineers' instruments differ in the various nations as the requirements of engineering practice and thus American engineers' instruments possess a distinct character of their own as compared with other nations, having as a rule few parts

affect the magnetic needle. In the construction of an instrument such a distribution of the metals is aimed at that the greatest strength consistent with light weight may be obtained and that the metals coming into contact at the bearing surface may be of such varying composition as to cause the least friction.

Take, for the purpose of better illustration, an American transit, illustrated herewith, as typical, as far as the construction is concerned, of nearly all engineering instruments. The plate of the instrument on which the magnetic needle is mounted, or as it is termed, the compass circle, is turned with great care so that the surface may be absolutely true and is gradu-

ated usually into 720 spaces, each representing one-half of a degree.

Compass circles are usually figured in quadrants of a circle, that is, from 0 at the point marked "N" or "North" to 90 and back again, while the figuring of the limb varies with the custom of the maker or the requirements of the engineer.

In engineers' instruments, however, the angular measurements are made usually without the use of the needle, by a telescope so mounted as to revolve in a vertical or a horizontal plane. The angular measurement of its movement is indicated on circles divided into fractional spaces of a degree and read for convenience to finer spaces by one or more verniers. Accuracy of graduation of the compass circle, and especially of the limb, is essential to the perfection of the instrument, and great pains are taken by manufacturers in perfecting and improving engines for graduating. The best machines are automatic in action and the spaces are so accurately laid off that there is no appreciable error in the finished work. The instrument rests on the socket or bearing surface to which the compass plate and limb are

rays of light entering the object glass may be properly refracted and concentrated at a point called the focus.

The making of the lenses is an operation requiring much skill in manufacture, as upon the accurate grinding of the curved surfaces depends the quality of the telescope.

At the focus of the object glass are placed the cross-wires, which are filaments of spider web or very fine platinum. In conjunction with these are often used two more wires commonly called stadia wires, so placed that they intercept on a rod a space proportional to its distance from the instrument, thus furnishing an efficient method of ascertaining distances directly by the observer. The metal parts of the instrument, having been prepared, are polished with some suitable material, a preparation of rouge being generally used for finishing the surface of the screws, and the larger surfaces being finished with fine emery paper. The larger parts are usually colored dark to avoid reflection of the sun, while the smaller ones, such as screws, etc., are left bright in order that there may be a pleasing contrast between the different parts of the instrument. The

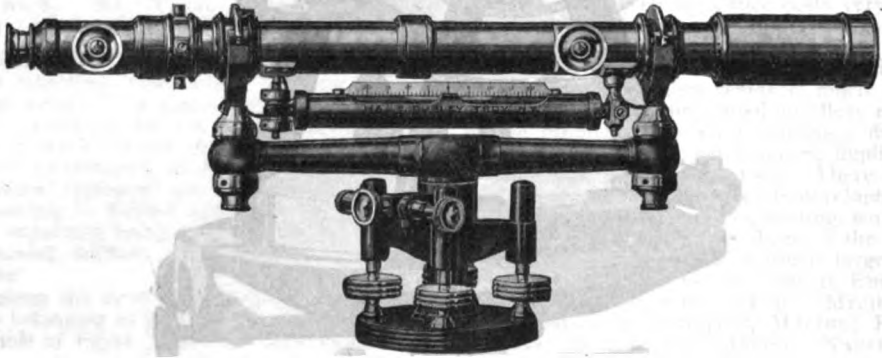

Engineer's Wye Level.

attached; the surfaces of the socket must be so accurately fitted together as to produce no error when the parts are moved on each other. The socket is mounted on a leveling head, which is actuated by three, or in the usual American practice, by four leveling screws, as shown, by means of which the instrument can be accurately leveled. Upon the compass plate are placed the standards which support the telescope, the preparation of the optical parts of which is next in importance to the fitting of the socket and the graduation.

The telescope consists of an eye piece and object glass mounted in a tube. The eye piece is simply a magnifier of the image produced at the focus of the object glass. Two kinds of eye pieces are used, one showing the image erect, and the other showing the image inverted. The object glass is composed of two plates of optical glass of such specific gravity and refractive index that it will magnify the image clearly without prismatic colors. To secure achromatism the two parts of the object lens are made the one of crown and the other of flint glass, the crown being a light glass of soda and silica and the flint being a heavier glass containing potash and lead. The surfaces of each are curved to such a degree that the

parts, prepared as above, are covered with a thin coat of lacquer, a preparation of shellac and alcohol, applied after heating. All the parts are assembled and fitted together, and the instrument is then ready for the final complete adjustment. This consists in fitting the sockets so that they will move freely on each other, placing the compass plate and limb in position on the sockets, making the limb truly concentric with the socket and placing the verniers in position. The telescope must be so adjusted that its parts may work freely, and having been supplied with optical parts, etc., it is then fitted to the standards or supports previously placed in position on the compass circle. The whole instrument is then tested for accuracy and if found correct is packed in its case and is ready for use.

The above description is only intended to give a general idea of the construction of a typical instrument, but the same methods will practically apply in the construction of all engineering instruments, such as levels, plane-tables, alidades, and the various kinds of compasses, etc.

**ENGINEERING SCHOOL.** See EDUCATION, TECHNICAL.

**ENGINEERING TERMS.** Engineering has spread into so many branches that it is difficult to differentiate between them and much more difficult to separate the technical verbiage of the several divisions of the profession. The more common technical terms have therefore been gathered together here for the benefit of the lay reader.

- ABUTMENT.**—A side support or buttressing structure to resist lateral pressure, as the abutment of a bridge-pier; anything that abuts or stands out as a support or brace.
- ACTION.**—The active moving parts of a machine, as a piano-action (the keys, levers and connections for sounding the strings). Also a single complete movement or stroke; used mostly in the phrases single-action and double-action, the latter being an action performed on both strokes of a reciprocating part.
- ANNEALING.**—The process of heating and slowly cooling, as for reducing the brittleness and increasing the toughness of glass or steel. Also fixing an enamel or color on earthenware or china by heating and cooling. The annealing-arch of the glassmaker is called a leer.
- ANNULAR.**—Ring-shaped.
- APEX.**—The top of a cone, pyramid, truss, outcropping of ore, etc.; the vertex of an angle, either plane or solid.
- AQUEDUCT.**—A water conduit. See **AQUEDUCTS**.
- ARMOR.**—A thing constructed for protection or defense, especially the steel plates of a war-vessel; any protecting device, as steel wire wound around a submarine cable, a diver's suit, etc.
- AXIS.**—The theoretical line around which a thing turns; one of the principal lines drawn through the centre of a geometrical figure, especially the longest and shortest of such lines; in early use, an axle.
- AXLE.**—The central fixed part on which a wheel turns, especially a rod or bar on a vehicle having a spindle on each end for a wheel. Compare, 'Shaft' in this list.
- BALANCE.**—The condition when opposed forces exactly counteract each other; equality of forces; equilibrium; also any device or mechanism that secures equilibrium, as a pair of scales; any weighing mechanism whose essential part is a scale-beam. Any one of similar instruments, as a torsion-balance, electric balance (Wheatstone's bridge), the balance-wheel of a watch, etc.
- BATH.**—A tank or a solution in a tank, as for electroplating; also the molten mass in a reverberatory furnace.
- BEARER.**—A supporting part, that receives weight or strain.
- BEARING.**—The box or journal (or simply a hole) in which a moving or rotating part rests, holding it in position. See **BEARINGS**.
- BELT.**—A continuous band or strap, as of leather, for transmitting power, as from one pulley to another, or for conveying. (See **CONVEYER**). They are sometimes made of rubber, cotton or steel. Cotton is adopted as a cheap substitute for leather; steel has to be made very thin, and if bent around small pulleys is liable to fracture. The leather belt, having moderate elasticity, is generally preferred, as it adheres to pulleys by friction, and slips in case of accidental stoppage.
- BELTING.**—A system of belts, also belts collectively.
- BENDING MOMENT.**—The sum of the external forces which act upon each side of a given section of a beam bending under a load. It is equal to the "moment of resistance" of that section, or the sum of the internal forces or stresses set up therein by the bending action.
- BLOCKING OR BLOCKING-UP.**—The elevating and supporting of large pieces of machinery, or entire structures, by means of cranes, jacks, and blocking or short lengths of timber and planks, during erecting and constructing operations. Also the elevation given to the outer rail of the curve of a railway track, for the purpose of counteracting the effect of the centrifugal force developed by a rapidly moving train.
- BOILER.**—The steel tank or container in which water is boiled to make steam. (See **BOILER**). Also a hot-water cooking or scalding device.
- BOLT.**—A rod of metal for tightly securing together the parts of a structure, having usually an enlarged end called a head, and at the other end a threaded portion for holding a nut; when threaded at both ends called double-ended; when made with a ring or eye at one end called eye-bolt. (Compare 'Rivet' in this list). Also the bar or main sliding piece of a door-lock; also a block of wood suitable for cutting into shingles, staves, etc. In flour milling, a rotating sifting cylinder.
- BORING.**—An operation not to be confused with drilling. See **BORING**.
- BRAKE.**—A mechanism for restraining or retarding some motion or action. It may be a simple shoe of metal or wood, with a lever for pressing it against a wheel; or an encircling band of metal on a drum, as on an automobile; or a complex system of mechanism, as an air-brake (q.v.). Brake horse power is the amount of power delivered by an engine or motor at the driving pulley or pulley shaft, and actually available for doing work.
- BRIDGE.**—(See **BRIDGES**). Also one of various cross-pieces or minor mechanisms likened to a river-bridge, as a low dividing wall in a boiler; a horizontal scaffold; an electric balance used in measuring electric resistance — a Wheatstone's bridge.
- BRIDGING.**—Short wooden braces or struts placed between joints to secure them in position.
- BRITISH THERMAL UNIT.**—(Abbreviated B. T. U.) — The amount of heat required to raise the temperature of water one degree Fahrenheit, at or about 39.1°F. To convert values of energy expressed in foot-pounds to their equivalents in British Thermal Units, divide the values by 778.
- BY-PASS.**—A pipe arranged to pass by or around a valve and permit a fluid to take another route.
- CAISSON.**—A large water-tight box or casing, usually with an open bottom and shafts through the top, for carrying on working operations under water. Air-locks are placed in the shafts and the men work under air pressure. It is much used in laying foundations for piers and docks.
- CALENDER.**—A pair of rolls, or more usually a machine including several pairs of contacting iron cylinders, used in surfacing paper, cloth, etc.
- CAMBER.**—The upward curvature given to an arched bar or structure in order to compensate for the downward curvature resulting from the application of the load. In machinery, it is specifically applied to the arching of springs like those of locomotives. In structural work, it is applied to the arching of bridge trusses like the stiffening trusses of suspension bridges.
- CANAL.**—An artificial waterway, as for transportation of barges or for drainage. (See **CANAL**). Also a channel, groove or duct.
- CASTLEVER.**—A large counterbalanced truss-section of a bridge, that may be built out over the water, and sustained by the balancing weight of an opposite part projecting from the other side of the pier; a balanced truss. Also a bridge having such trusses. (See **BRIDGES**). In architecture, a bracket for a cornice, etc.
- CASTING.**—See **FOUNDRY PRACTICE**.
- CEMENT.**—See **PORTLAND CEMENT**.
- CENTRE.**—The middle of a thing; in various special uses. In machine designing, that one of two points in a crank motion which marks the end of a piston-stroke — a dead centre; in lathe-work, one of the conical points supporting the work, the one at the driving end being termed the live centre. In geometry, the fixed point about which the radius of a circle or a circular arc moves; the central point of a closed curve. In architecture, the centring support of an arch or dome. The "centre of buoyancy" of a vessel is the central point of compression of the forces that buoy her up. It must be above the centre of gravity or the vessel will capsize. The "centre of compression" is the line in which the resultant of the compressive forces in the lower part of a beam is located. The "centre of gravity" is the point in a body about which the body will remain balanced when placed in any position. The "centre of gyration" is the point in which the momentum of a revolving body is concentrated. The "centre of moments" is the point about which the forces applied to a rigid body act. The "centre of oscillation" is the point in the axis of a vibrating body, such as a pendulum, in which if all the matter of the body were concentrated, the body would vibrate in the same time. The "centre of tension" is the line where the resultant of the tensile forces in the upper part of a beam is located.
- CIRCULAR INCH.**—The area of a circle one inch in diameter, as distinguished from a square inch. The number of circular inches in a given diameter is obtained by squaring the diameter.
- COEFFICIENTS.**—Numerical values deduced from data obtained by experiments and used as constant multipliers in engineering calculations. They have been determined for friction, elasticity, tension, rupture, resistance, the flow of water, etc. For example — the amount of force or weight that will elongate an elastic bar of any material and of uniform section to twice its original length is designated as the "coefficient of elasticity" of that material. Also termed "modulus" as the "modulus of elasticity," the "modulus of resistance," etc.
- COHESION.**—The condition of things that stick or cleave together; the union of particles, especially small particles, or the force that brings them together. Solids have great cohesion or tensile strength; liquids have little and gases none. See "Tension" in this list.
- COLUMN.**—An upright beam, shaft or truss, as for supporting a structure. The classical column is cylindrical and tapered, with a slight bulge at the centre of height. The concrete structural column may be square or rectangular. The steel column is frequently formed of several beams riveted or laced together.
- COLUMNATION.**—The arrangement of columns in a building or portico.
- COMBUSTION.**—Burning; the continuous combination of a substance with oxygen (or chlorine, etc.) with flame and generation of heat. The best economic combustion of coal has been the subject of exhaustive experiment. The gases of combustion are the vaporous portions of smoke.

- COMPRESSION.**—The act or process of concentrating or condensing by pressure; the forcing of something into reduced space. Air is compressed by a machine built like a steam-pump, the piston packing and condensing the air in the cylinder at each stroke. Air so compressed is used for producing power, and for supplying workers in caissons, tunnels, mines, etc. In a gas-engine the mixture or explosive charge is subjected to pressure to heat it and increase its explosive properties. The members of a truss that are strained by longitudinal pressure are called compression members. See 'Truss' in this list.
- CONCENTRATOR.**—A machine used in ore-concentration to bring together the richer portions of mineral content; a jigger or vanner.
- CONDENSER.**—Any one of various devices for condensing: (1) a contrivance for suddenly cooling and thus condensing exhaust steam. (See **STREAM AND STREAM-ENGINE**). (2) A mutual induction apparatus. (See **CONDENSER**). (3) A lens or combination of lenses in a microscope or other optical instrument, for concentrating light rays. (4) In cotton-ginning a device for compacting lint, etc. (5) A mechanism for separating impurities by condensation from illuminating or fuel gas.
- CONSTANT.**—A number deduced from data obtained by actual tests made upon the strength of a particular material, and used in calculations relative to the strength of structures built of that material. For example—having ascertained by actual experiment the weight required to rupture a steel bar measuring 3 x 2 x 1 inches, that weight can be used to estimate the stresses in structures made of the same material but differing in length, breadth, and depth.
- CONVEYOR.**—See **CONVEYER**.
- COUPLE.**—In physics, two equal and opposite forces acting upon a body, which is therefore in a state of equilibrium. Also any two similar things joined together so as to be a pair, as two different metals joined in a thermopile.
- CREEPING.**—Slow movement caused by conditions not easily foreseen, as the creeping of a railway track due to unusual heat and expansion of the rails. If a belt tends to work slowly out of position, or a machine through vibration gradually shifts its place on a floor or foundation, it is said to creep.
- CRUSHER.**—See **CRUSHING AND GRINDING MACHINERY**.
- CYCLE.**—In mechanics, a series of motions that repeat.
- CYLINDER.**—A solid bearing two flat surfaces or ends, connected by one continuous round surface; when relatively short called a drum; when relatively long a round rod, column, etc. Familiar examples of the cylinder are found in the steam-engine and the printing press.
- DATUM or DATUM LINE.**—Any base line from which measurements are made, or dimensions taken, either in actual work, or in graphical calculations.
- DEALS.**—Sawn timber which usually measures not less than 3 x 9 inches, and not more than 3 x 12 inches in cross section.
- DIFFERENTIAL.**—A mechanical motion, in which the operation of some part is determined by the difference between the action of two other parts. For instance, if one part is making 10 R.P.M. and another 40 R.P.M., the differential governed by them will make 25 R.P.M.: called also **Differential Motion**. The most common illustration is the differential on the rear axle of an automobile. The term differential is also used to describe a double screw, having two sets of threads of different pitch, or some other mechanism embodying different double action.
- DIGESTER.**—A chemical apparatus for digesting or partially dissolving something by heat and moisture.
- DOCK.**—A wharf or pier, as on the margin of a body of water, to which vessels may tie up and load or discharge cargo. The term dock is more commonly used in England than America to describe the enclosed basin where vessels locate in a harbor. In the United States the term pier is more common, representing one of a row of long wharves with slips between which the vessels lie. In America the word dock is used mainly for the dry dock, being a basin in which a vessel can be docked, and the water pumped out, so that repairs can be made to the hull. A floating dock is an enormous structure, into which a vessel can be floated, and then by closing the gates of the dock and pumping out the water, the vessel is left dry resting on the floor of the floating structure.
- DRILL.**—See **DRILLS AND DRILLING**.
- DRIVING.**—The act or process of moving or directing the motion of some other thing, especially that part of a machine that imparts power or momentum to other parts, as a driving-pulley or driving-axle. A driving gear is the combination of parts in the gear or mechanism that drives a machine; a driving-shaft is a power-shaft, usually having fixed pulleys for driving belts, or gears or clutches for communicating the power to the thing driven. When two wheels are geared together the one that is nearest the source of power and that imparts motion to the other is called the driver, while the wheel that receives motion is a driven wheel. To calculate the mechanical efficiency of a train of gearing, multiply the radii of all the drivers together, and likewise the radii of all the driven, and divide the latter by the former.
- DUTY.**—The efficiency or useful work accomplished by an engine or motor; also the amount of such work, usually stated in footpounds. The duty of a steam engine is the number of pounds raised to the height of one foot by the burning of a bushel of coal. In the case of pumping engines, the duty was formerly expressed in millions of pounds of water lifted to the height of one foot by the burning of 100 pounds of coal; but, as the quality of coal varies greatly, the basis now employed is the work done by 1,000 pounds of dry steam, or by 1,000,000 British Thermal Units.
- DYNAMICS.**—See **DYNAMICS; ELECTRIC MACHINE**, etc.
- ECCENTRIC.**—A wheel, gear, etc., mounted out of centre, so that its periphery has an irregular or eccentric motion, which may be used in a manner very similar to cam-motion. See **MECHANICAL MOVEMENTS**.
- EFFICIENCY.**—The efficiency of a machine or of a structure, or any portion thereof, is the ratio of its strength, power, or capacity, to that of some predetermined, understood, or fixed standard of reference. For example—the efficiency of a riveted joint in plate work is its percentage strength calculated relatively to that of the solid plate. The efficiency of a machine is the ratio of its actual value to its theoretical value, or the difference between the amount of work expended on the machine and the amount given out by it or obtained from it. See **EFFICIENCY ENGINEERING**.
- ENCASTRE.**—The immovable fixing of the ends of a cantilever, or the ends of other forms of beams or girders in a wall or support. Beams are much stronger when encastre than when simply supported.
- ENERGY.**—Inherent capacity for doing work, as distinguished from force, which is energy in action in a definite direction, and power, which is the quantitative idea of force, without reference to direction. (See 'Force,' 'Horse Power' and 'Power' in this list). We speak of kinetic energy, meaning energy in motion, that is active and exhibiting motion, and which is theoretically equal to the product of half the mass into the square of the velocity. Potential energy is applied to stored energy, as in a pound of coal, which when consumed and used to make steam appears as kinetic energy. A storage battery when charged has potential energy, though it may lie idle. Electric energy is defined as molecular kinetic energy. (See **ELECTROM**). Radiant energy is light, radiant heat, X rays or any form of energy transmitted through the hypothetical ether.
- ETHER.**—A theoretical medium supposed to fill all space and pervade all substances, being that in which electricity, light, radiant heat, cathode rays and similar phenomena are promulgated. According to this theory electric phenomena are strains and pulsations in the ether. See **ETHER**.
- EXPANSION.**—Increase of volume, especially of steam, gas or other motive fluid. Also the point in a piston-stroke at which such expansion becomes available and the period during which expansion takes place in an engine cylinder. When compound cylinders are employed it is termed double expansion, and if there are three or four steam-cylinders used in series it is termed triple, quadruple or series expansion. See **STREAM; STEAM-ENGINE**.
- FACTOR OF SAFETY.**—When calculating the ultimate strength of a structure it is necessary to provide for contingencies arising from a lack of uniform quality in materials, inferiority of materials, wear and tear of parts, the unexpected application of loads, etc. This provision is made by the use of multipliers such as 4, 6, 8, and in some cases 10, which are applied to certain dimensions. For example—the application of a factor of safety of four will give a structure having four times the strength necessary to carry the load it will be ordinarily required to sustain.
- FEEDING.**—The supplying of material to a machine or the like, as feeding of coal by a mechanical stoker, feeding of sheets of paper to a printing press, feeding logs to a sawing machine, or cotton to a breaker.
- FLUE.**—A channel or passageway for smoke, waste gases, etc., as a subsidiary tube or smoke-duct in a chimney, or a tube carrying gases of combustion in a boiler, or a hot-air passage in a wall. It is distinguished from pipe and tube.
- FLY-WHEEL.**—A relatively heavy wheel added to a machine for the purpose of maintaining uniform speed: called fly-wheel because it simply rotates or flies around. It resists sudden acceleration of speed by its inertia, and is useful in machines that do their work in a small fraction of a cycle, to prevent slowing up or racing.
- FORCE.**—Energy in action with reference to its direction; mechanical power as apparent in pushing, pulling, rotating, attracting and repelling; exertion that can be measured in pounds or units. Force always has direction, while energy has not, being rather the static idea. A storage battery may possess great energy, and yet exhibit no force for lack of a conductor. Compare 'Energy,' 'Power' and 'Horse Power,' in this list.
- GAS.**—Matter in the aeriform state, usually invisible and apparent to the senses only by its odor or motion. Coal gas, water gas, petroleum vapor and various other gases, when mixed with atmospheric air in a proportion of about 1 to 10, readily explode when in contact with a flame,



- and this principle is used in the internal combustion engine. See INTERNAL COMBUSTION ENGINE.
- GEAR.**—See GEARING and MECHANICAL MOVEMENTS.
- GOVERNOR.**—A device for speed-regulation, as of an engine or motor, the most common type being the ball-governor used on steam-engines to prevent racing.
- GRAPHIC STATICS.**—The graphical methods employed for ascertaining the strains on structures, velocity ratios, etc., by means of lines drawn to a uniform scale and representing the direction and intensity of active forces.
- HORSE POWER.**—A theoretical unit of work, assumed to be the equivalent of what a horse can do; it equals 33,000 pounds lifted one foot in one minute. The power of engines and motors is frequently expressed in horse power units. A.H.P. is actual horse power; B.H.P. is brake horse power; I.H.P. is indicated horse power; and F.H.P. is friction horse power. Horse power is also the name of a form of tread-mill in which the traction power of horses is utilized in place of an engine or motor.
- INERTIA.**—Resistance to change of motion due to mass or weight; persistence in a given motion or state of rest.
- INGOT.**—A mass of cast metal from a mold. The more valuable metals when not shaped as bars or rods are usually cast in ingots; iron is cast in pigs.
- INTERCHANGEABLE SYSTEM.**—That system of manufacturing machinery by which each part or piece is so exactly formed or machined that it may be replaced by any similar part. It originated in America and has become general. See INTERCHANGEABLE PARTS.
- LAP.**—A part that extends beyond the body of a thing over some other part, specifically, in steam-engineering, the extension on a slide-valve that determines the instant of opening or closing a steam-port. Also a piece of soft wood, metal, leather, etc., for polishing.
- LOAD.**—The weight or pressure a structure carries or sustains, distinguished as live load when moving, as of wagons on a bridge, and dead load when stationary. Live load is liable to create twice the stress of dead load, and must be provided for in the strength of the structure.
- MACHINE TOOL.**—A machine for cutting, planing, drilling, turning, milling, etc., with cutters or small tools; formerly called engine-tool.
- MOTOR.**—A machine for transmitting power, as of water under head, or by electricity, as distinguished from an engine where the power is assumed to originate in the machine. See ELECTRIC MOTOR.
- MINE.**—An excavation in the ground for the purpose of obtaining some metal or mineral. Also a buried or submerged explosive.
- MODULUS.**—A number or coefficient for the measure of a force or function. See 'Coefficients' in this list.
- MOLDING.**—See FOUNDRY PRACTICE.
- OSCILLATION.**—A swinging from side to side, or short regular reversal of rotation; also vibration, as of electric waves. Compare 'Reciprocation' in this list.
- PATTERN.**—A model or original form of a piece designed to be cast, as for forming in iron. See FOUNDRY PRACTICE.
- PILE.**—A large heavy timber, pointed and driven small-end-first into the ground, as a support for a superstructure; commonly used in muddy places or on the edge of a body of water for securing a foundation; formerly called a spike. Now made also of concrete, or steel and concrete. Sometimes metal planks are used for the same purpose, or to form a breakwater or stout wall, and are termed sheet piles.
- PIPE.**—A long hollow tube, either one piece or a series of connected pieces. The distinction between pipe and tube is usually arbitrary, but when the article is made of soft, yielding material, as rubber, the correct term is tube.
- POWER.**—Mechanical energy as viewed from the standpoint of capacity; the measurable amount of active energy; capability of performing a given amount of work. Compare 'Energy,' 'Force' and 'Horse Power' in this list.
- PRESSURE.**—Stress such as would tend to move a body in contact; the impelling force of a load. It is usually estimated by units of weight. See 'Load' and 'Stress' in this list.
- PRIME MOVER.**—An engine or the like from which a power originates. The electric dynamo depends upon the steam-engine or water-wheel as its prime mover.
- RACING.**—Running at an excessive speed, as an engine suddenly released of its load. It is liable to burst a fly-wheel if not checked.
- REAMING.**—The enlarging of a hole by inserting and turning a tool termed a reamer; done to taper a hole or remove edges weakened by punching.
- RECIPROCATION.**—The act of moving back and forth systematically, as a piston. Compare 'Oscillation' in this list.
- REDUCING.**—Drawing to a smaller scale; also tapering in diameter; also the smelting or reduction of ore in a furnace; also the act of withdrawing fluid under pressure; as by a reducing-valve.
- REVOLVING.**—Turning around in an orbit, after the manner of a planet, or a ball in a ball-bearing. Such a ball rotates on its own centre, but revolves around the center of the bearing. See 'Rotation' in this list.
- RESISTANCE.**—That which opposes a force or movement. An electric resistance is a poor conductor, as an iron wire, placed in a circuit to impede the current.
- REFLECTORATORY.**—Reflecting, or operating by reflection, as a puddling furnace, where the flame and heat are reflected from the vaulted roof to the top of the material to be fused.
- RIVET.**—A short metal connection for holding metal plates together, resembling a bolt, but instead of having a threaded end and nut, the tail end is designed to be upset, that is battered and spread, to keep it tight in its hole.
- ROLLING.**—Passing between heavy iron rolls to reduce and shape, as steel rails and beams. Also calendaring.
- ROTATION.**—The act of turning around its own centre. Compare 'Revolving' in this list.
- SHAPE.**—A machine tool for cutting or machining small metal parts, the work being stationary, and the cutting tool mounted to reciprocate.
- SPINDLE.**—A slender rod or pin, usually for some rotary purpose, as the central rod of a bobbin.
- SPINNING.**—In metal working, the operation of drawing out and expanding into a cup or cone form, by pressure and rotation. In textile manufacture, the drawing out and twisting of sliver to form thread.
- STAMPING.**—The operation of forming light metal articles in the cold by a sudden blow of a die. Also the crushing of ore in a stamp-mill.
- STATIC.**—At rest or in equilibrium. See ELECTRICITY.
- STOKING.**—The supplying of a furnace with fuel. Mechanical stokers are common for supplying coal under stationary boilers but are not adapted to marine use.
- STRENGTH OF MATERIALS.**—The engineer is continually confronted with this problem, and elaborate tests are now undertaken to secure uniform and known strength in structural materials. The force that resists being pulled apart is termed tensile strength; that resisting crushing is termed strength of compression. There is also torsional and bending strength.
- STRESS.**—Any force or power that tends to deform, bend or fracture a thing; especially, such a force considered with its reaction or opposing force.
- STUFFING.**—In steam engineering, a packing of spiral steel rings for making a fluid-tight joint for a moving part, as a piston-rod.
- SWITCH.**—A mechanism for side-tracking a thing. An electric switch is usually a jointed piece of copper with insulated handle by which conductors can be connected or disconnected. A railway switch is a pair of jointed and pointed rails for guiding car-wheels to an adjacent track. A weaver's switch is a reversing motion for a shuttle.
- TEMPERING.**—The process of bringing steel, etc., to a certain degree of hardness by heating and sudden cooling in water or oil. Also the process of bringing clay to proper working condition by moistening and kneading.
- TEMPLATE.**—A flat pattern, usually of metal, serving as a guide in various cutting, drilling and shaping operations. Also spelled templet.
- TENSION.**—The force or system of forces tending to draw a body apart or lengthen it; pulling stress as opposed to compression. A tension member of a truss is a rod that is subjected to a pulling strain.
- TESTING.**—The operation of testing materials. See 'Strength of Materials' in this list. A testing machine pulls apart pieces of metal and measures the elongation and strain of rupture, and also determines crushing or compression strains.
- THREAD.**—A spiral projection on a screw for enabling it to grip a softer substance, as wood, or to fit into a reverse thread in a nut.
- TRAIN.**—A series of parts acting together, as a train of gears.
- TRANSMISSION.**—The passage of something over or through some other thing, as heat through the air, or electricity through a copper or aluminum wire. Also the sending mechanism of a telephone. Also a mechanism that transmits power in a given way, as the transmission of an automobile.
- TRUSS.**—A braced framework, calculated to resist strains in all directions, as used in bridges, roofs, etc.
- TUBE.**—See PIPE.
- TURBINE.**—A flanged wheel or circular structure, calculated to receive the impact of rapidly moving water, steam, etc., and deliver a large part of it as power on a shaft. See HYDRO-ELECTRIC DEVELOPMENT.
- UNIT.**—A given minor quantity represented by 1, for calculating the quantities of things. The fundamental units are the metre and foot for length, pound and kilogram for weight, second for time. See METRIC SYSTEM; also ELECTRICAL UNITS.
- WORK.**—The accomplishment of machinery or mechanical motion by the expenditure of energy. The work done by lifting 10 pounds 10 feet is 100 foot-pounds.
- WORKING.**—Adapted to work; accurate in operation, as a working model.

CHARLES H. COCHRANE,  
Author of 'Modern Industrial Progress.'

**ENGINEERS, Corps of**, a branch of the United States army which takes charge of the construction and repair of fortifications, both temporary and permanent, military reconnoitering and surveying, the selection and planning of camp sites, the construction and maintenance of roads, railroads, bridges, storehouses, etc., and divers other technical services which are not under the supervision of special branches of the army. It also superintends river and harbor improvements, the collection and preservation of documents relating to the Washington aqueduct and public buildings in the District of Columbia and the construction of bridges and roads in the Crater Lake and Yellowstone National Parks. The Panama Canal was built under engineer officers.

Engineer officers were authorized by Congress on 16 June 1775 and in the same year Col. R. Gridley became chief engineer. Many French engineers served with the United States army during the Revolution. A corps of artilleryists and engineers was established by the act of 9 May 1784. In 1802 the artillery and engineers were separated and the Corps of Engineers was established. This was gradually increased in size until the present establishment is 505 officers, one band, seven regiments and two mounted battalions. In 1813 appointments were first made to the rank of topographical engineer. After various vicissitudes, the topographical service of the army was organized as the Corps of Topographical Engineers in 1838. In 1863 this corps was merged in the Corps of Engineers.

Engineer officers are appointed, in general, from West Point, although competitive examinations are held which are open to civilian engineers. Commissions in the engineers are generally given to those West Point cadets with the highest academic standing. Officers in the Corps of Engineers are considered as in the line when they are on service with engineer troops. Otherwise they are staff officers.

During the Great War the uses of engineer troops and the organizations which they form have undergone great diversification. Whereas the engineer troops of the United States army were formerly grouped into pioneer regiments, mounted pioneer battalions and pontoon battalions, there are now also labor regiments, railroad regiments, lumbering regiments and so on indefinitely, made up from men in the National Army or National Guard and under engineer officers. The technical training of officers of the Corps of Engineers is divided between the United States Engineer School at Washington and the Army Field Engineer School at Fort Leavenworth. The Royal Engineers of the British Army, the "technische Truppen" of Germany and the Engineer Corps of the French Army correspond very closely to the United States Corps of Engineers, but perform work which belongs to the American Signal Corps as well. The foreign corps also differ from the American in that they draw in general from technically trained men, whereas in times of peace American engineers receive the greater part of their training after enlistment. See **ARMY ORGANIZATION**; **UNITED STATES, ARMY OF**.

**ENGIS**, ön-zhè, Belgium, on the Meuse, southwest of Liège, in the neighborhood of which there are many caves. In these, in 1832,

there were discovered by Dr. P. C. Schmerling a human skull and parts of a man's skeleton together with bones of the rhinoceros, mammoth, cave-bear and hyena imbedded in deposits belonging to the Quaternary period. This discovery gave cause for much discussion among anthropologists. The skull, usually known as "the Engis Skull," though of uncertain age, is beyond any doubt very old. Similar discoveries were made in nearby caves, especially at Engihoul. Consult Avebury, J. L., 'Prehistoric Times' (7th ed., London 1913); Doudon, E., 'Nouvelles explorations dans les cavernes d'Engihoul' (in Soc. d'Anthrop. de Paris, *Bull. et Mem.*, Ser. V, Vol. IV, p. 177, Paris 1903); Dupont, E. F., 'Les Temps Préhistoriques en Belgique' (Brussels 1873); Huxley, T. H., 'Man's Place in Nature' (New York 1899); Schmerling, P. C., 'Recherches sur les ossements fossiles découverts dans les cavernes de la province de Liège' (Liège 1833); Spring, 'Les Hommes d'Engis et de Chauvaux' (in *Bulletins de L'Académie Royale de Belgique*, Ser. II, Vol. XVIII, pt. 2, No. 12, Bruxelles 1864).

**ENGLAND, John**, American Catholic prelate: b. Cork, Ireland, 23 Sept. 1786; d. Charleston, S. C., 11 April 1842. He was educated in the schools of Cork and studied law for two years, but in 1803 entered the theological college of Carlow. Here his progress in his studies was so brilliant that after his second year he was selected to deliver public lectures on religious subjects. He also devoted much of the time given him for recreation to the instruction of the militia stationed in the town. He also founded an asylum for unprotected females which afterward suggested the plan of the Presentation convent and established free schools for the education of poor boys. In 1808 he was recalled by his bishop and appointed president of the theological seminary at Cork. He took a leading part in the agitation for Catholic emancipation and, with the view of helping the cause of religious liberty, founded the *Chronicle*, which he continued to edit until his departure from Ireland. When the see of Charleston, embracing the States of North Carolina, South Carolina and Georgia, was founded Dr. England was nominated its first bishop. As he had determined to become an American citizen he refused to take the oath of allegiance exacted from Irish bishops on their consecration. After some difficulty he was consecrated in Cork in 1820 and arrived in Charleston the same year. He had many obstacles to contend with. There were only two priests and two churches in the three States under his jurisdiction and his flock was made up chiefly of poor Irish emigrants and refugees from Santo Domingo. In order to provide priests for his diocese he opened a classical school in Charleston, and the success that attended his efforts in this respect enabled him to support several of his ecclesiastical students. Not only did he succeed in training a body of educated missionaries for his church, but contributed largely to the revival of classical learning in South Carolina. Several schools were reopened and the College of Charleston, which had suspended for some time, resumed its studies. He infused new life into the Philosophical Literary Association of Charleston as soon as he became a

member and did much to suppress dueling, not by intemperate denunciations but by forming the most influential gentlemen of the State into an anti-dueling association. He was invited by Congress to preach in the Hall of Representatives at Washington and was the first Catholic clergyman on whom this honor was conferred. To explain and defend the doctrines of his church he established the *United States Catholic Miscellany* at Charleston. It was through the columns of this periodical that most of his writings found their way to the public. His influence was felt in every part of the Catholic church in the United States and his influence at Rome was decisive in affairs connected with the church in America. His courses of lectures, which he delivered in all the great cities of the Union, were attended by citizens of every creed. Nothing, however, endeared him to the people of Charleston so much as his heroism during the frequent visitations of the yellow fever, when he continued at his post night and day. In 1834 he visited Ireland and obtained the services of three nuns of the Ursuline Order, by whose aid he established the Ursuline schools of Charleston. He also founded orphan asylums, boarding-schools and free schools, which he placed in charge of the Sisters of Our Lady of Mercy. He conceived the plan of assembling the prelates in council for mutual aid, and has been styled "the author of our provincial councils." He visited Europe four times in the interests of his diocese, was sent twice as Apostolic Delegate to Haiti and was offered an Irish See, which he declined. On his return from Europe in 1841 malignant dysentery broke out among the steerage passengers, and Dr. England's attendance on them was incessant until he was attacked by the disease himself. He finally died from its effects, which were heightened by overwork. His principal works are 'Discourse before the Hibernian Society of Savannah' (1824); 'Explanation of the Construction, Furniture and Ornaments of a Church'; 'Letters on Slavery'; and "Works," edited by Bishop Reynolds (5 vols., Baltimore 1849).

**ENGLAND**, including **WALES**, the southern and larger portion of the island of Great Britain, is situated between lat. 50° and 55° 46' N. and long. 1° 46' E. and 5° 42' W. England covers 42 per cent, and Wales 6 per cent, together 48 per cent of the whole area of the British Isles. For geographical, administrative and statistical purposes Wales is usually included with England, of which it forms a western peninsula, similar to the counties of Devon and Cornwall. Bounded on the East by the North Sea or German Ocean, which separates the territory from Germany, Holland, Denmark and Belgium; on the south by the English Channel, dividing it from France, and on the west by the Saint George's Channel and the Irish Sea, its only land frontier is that irregular line of 110 miles facing Scotland on the North. As the crow flies, that border line is barely 70 miles; forming a rough triangle, the eastern side measures 350 miles in a straight line; the western 425, and the southern 325 miles—a total of 1,170 miles. But the shores within this triangle are so deeply indented by bays and estuaries that the actual coast line is more than twice that distance, estimated at not less than 2,765 miles. The length of the coun-

try, measured on a meridian from Berwick nearly to Saint Alban's Head, is 365 miles. Its breadth, calculated on a parallel of latitude, attains its maximum between Saint David's Head, in South Wales, and the Naze, in Essex, where it amounts to 280 miles. The area of England without Wales is 50,873 square miles; that of Wales, 7,366; together, 58,239 square miles. The seas surrounding the British Isles are shallow. If the waters were to subside to the extent of 300 feet, the whole of the British Islands, including Ireland, would once more be united to Continental Europe.

**Geographical History.**—This great island possession of Rome had been virtually abandoned by the Romans (A.D. 410) before the Teutonic settlements in it began. The invaders had therefore to struggle rather with native Britons than with Romans. Moreover they were invaders who came by sea, and from lands where little or nothing was known of the Roman law or religion. They met with a degree of strictly national resistance such as no other Teutonic conquerors encountered, and therefore, in the end, they swept away all traces of the earlier state of things in a radical way which took place nowhere else. As far as such a process is possible, they slew or drove out the older inhabitants; they kept their heathen religion and Teutonic language, and were thus able to grow up as a new Teutonic nation in their new home without any important intermixture with the earlier inhabitants, Roman or British. The conquerors who wrought this change were the forefathers of the present day English,—the low Dutch inhabitants of the borderlands of Germany and Denmark. Among them three tribes, the Angles, the Saxons and the Jutes, had the chief share in the conquest of Britain. The Saxons had already attempted a settlement here in the 4th century and were consequently the tribe first known to the Roman and Celtic inhabitants of the island. Hence it came that the Celts of Britain and Ireland have called all the Teutonic settlers Saxons to this day. But, as the Angles, or English, occupied in the end by far the greater part of the land, it was they who, when the Teutonic tribes in Britain began to form one nation, gave their name to that nation and its land. That nation was the English and their land was England. While *Britain* thus remains the proper geographical name of the whole island, *England* is the political name of that part of Britain which was step by step conquered by the English. Before the end of the 5th century several Teutonic kingdoms had been founded in Britain. The Jutes began the conquest by their settlement in Kent, and presently the Saxons began to settle on the south coast and on a small part of the east coast, in Sussex, Wessex and Essex. Along a considerable portion of the eastern coast various Anglian settlements were also made, which gradually grew into the kingdoms of East-Anglia, Deira and Bernicia. By their ultimate union the last two formed the great kingdom of Northumberland. At the close of the 6th century, however, the English had not got very far from the southern and eastern coasts. The Britons, whom the English called *Welsh*, or strangers, held out in the west, and the Picts and Scots in the north. The Scots were properly the people of Ireland; but a colony of them

had settled on the western coast of northern Britain—distant at one part only 13 miles from Ireland—and in the end gave the name of Scotland to the whole northern part of the island.

The changes of boundary between England and Wales began with the great Welsh campaign of Harold in 1063. All the border shires, Cheshire, Shropshire, Herefordshire and Gloucestershire seem to have been enlarged at this period. The English border stretched to the Conwy in the north and to the Usk in the south. But part of this territory appears to have been recovered by the Welsh princes, while part passed into the great *march* district of England and Wales, under the rule of the Lords Marchers. The gradual conquest of South Wales began under the Conqueror and was continued by his sons; but it was more the work of private adventurers than of the kings themselves. The lands of Morganwg, Breheiniog, Dyfed and Ceredigion, answering nearly to the modern South Wales, were gradually subdued. In some districts, especially in the southern part of the present Pembrokeshire, the Britons were actually driven out, and the land was settled by Flemish colonists, the latest of the Teutonic settlements in Britain. Elsewhere Norman lords, with Norman, English and Flemish followers, held the towns and the more level country, while the Welsh kept up a semi-independence in the western mountains. In North Wales, meanwhile, native princes still ruled as vassals of the English king till the war of Edward I. In 1277 the vassal prince was compelled to relinquish again the territory east of the Conwy to his overlord. The final conquest followed in 1282, but complete incorporation with England did not take place until the reign of Henry VIII, 253 years later. During this long interim North and South Wales remained a separate dominion, giving the princely title to the eldest son of the English king, a dynastic custom that still exists to-day. Some shires were formed or remodeled, new towns founded, and the border districts maintained under the anomalous jurisdiction of the Marchers till the ultimate absorption in 1535. Thirteen new counties were then formed and some districts added or restored to the border shires of England. One of the new counties, Monmouthshire, was added to an English circuit under Charles II, and has since been considered an English county. Curiously enough, it frequently appears included with Wales even in official publications at the present time.

With the exception of these new creations, all the existing shires of England were in being at the time of the Norman Conquest, save those of Lancaster, Cumberland, Westmoreland and Rutland. The boundaries were not always exactly the same as at present, but the differences are commonly slight and of mere local interest. As they stood at the Conquest the shires were of two classes: some were old kingdoms or principalities which still kept their names and boundaries as shires, while others seem to have been mapped out afresh when the land was recovered from the Danes. All the shires on the Welsh border stretched further west in 'Domesday' than they do now. On the Scottish border Westmoreland and Cumberland were formed

out of the Cumbrian conquest of William II and enlarged by territory which appears in 'Domesday' as part of Yorkshire. Lancashire was made up of lands taken from Yorkshire and Cheshire, the river Ribble forming the older boundary of those shires. The older divisions are marked by the boundaries of the dioceses of York, Carlisle and Litchfield or Chester, as they stood until the changes under Henry VIII. In central England the only change was the formation of the smallest shire—Rutland—out of the Domesday district of Rutland, an appendage to Nottinghamshire, enlarged by a small part of what was then Northamptonshire.

If one were to trace these changes over a series of ancient and modern maps, they would reveal but very little alteration of boundaries in the island since the 11th century. The land, as a whole has not been mapped out afresh since the 10th century. While a map of France or Germany in the 11th century, or even in the 18th, would be useless for immediate practical purposes, a map of England in the days of Domesday (1085-86) hardly differs from the map of England as we know it to-day. The only changes of any import—and they are neither many nor great—are the shires on the Welsh and Scottish borders. William the Conqueror put the finishing stroke to the work of Egbert and made England forever one. By uniting that country under the same ruler as Normandy (namely, himself), he led her into the general current of continental affairs, and gave her a European position such as she had never held under her native kings.

Although there have been but slight changes in the boundaries of England itself within a thousand years, the extra-territorial expansion of that country beyond the seas constitutes the most remarkable phenomenon in the world's history. England alone is about the size of Rumania, less than a fourth of France or of Germany, and but little larger than the State of New York. England and Wales together are not equal in area to the State of Georgia, nor a quarter the size of Texas. There are 29 States or Territories in the Union each larger than England, and several much larger than the whole United Kingdom put together. Whilst the area of the British Isles is less than one-four hundredth part of the land surface of the globe, the colonies and dependencies which England has acquired within about 300 years cover something like one-fifth of the earth, or 11,351,046 square miles, with a population estimated at over 40,000,000.

**Topography.**—The chief indentations are: On the east, the Humber, the Wash and the Thames estuary; on the west, the Solway Firth, Morecambe Bay, Cardigan Bay and the Bristol Channel; those on the south are less prominent, though including some useful harbors. The greater part of the coast consists of cliffs, in some places clayey, in others rocky and sometimes jutting out into bold, lofty and precipitous headlands, as at Whitby and Flamborough Head on the east, Beachy Head, the Isle of Portland, the Lizard and Land's End on the south and southwest, Saint David's Head and Saint Bees Head on the west. The most extensive stretches of flat coast are on the east, in the county of Lincoln, and from the south part





# Environs of LONDON.



# IRISH SEA





# ENGLAND AND WALES

## SCALES

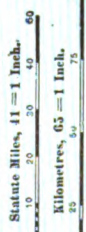

Rand McNally & Co.'s New 11 x 14 Map of England and Wales.  
 Copyright by Rand McNally & Co.





of Suffolk to the South Foreland in Kent, and in Sussex and Hants on the south coast. The chief islands are Holy Island, the Farne Islands, Sheppy and Thanet on the east coast; the Isle of Wight on the south; the Scilly Isles at the southwestern extremity; and Lundy Island, Anglesey, Holyhead and Walney on the west.

The loftiest heights of England and Wales are situated at no great distance from its west shores and consist of a succession of mountains and hills, stretching, with some interruptions, from north to south, and throwing out numerous branches on both sides, but particularly to the west, where all the culminating summits are found. The northern portion of this range has received the name of the Pennine Chain and is commonly designated "the backbone of England." It is properly a continuation of the Cheviot Hills, and, commencing at the Scottish border, proceeds south for about 270 miles, till, in the counties of Derby and Stafford, it assumes the form of an elevated moorland plateau. In Derbyshire The Peak rises to the height of 2,082 feet. By far the most important of its offsets are those of the west, more especially if we include in them the lofty mountain masses in northwestern England, sometimes classed separately as the Cumbrian range. Amid these mountains lie the celebrated English lakes, of which the most important are Windermere, Derwent Water, Conistone Lake and Ullswater. Here also is the highest summit of northern England, Sca Fell (3,210 feet). The Pennine Chain, with its appended Cumbrian range is succeeded by one which surpasses both these in loftiness and extent, but has its great nucleus much farther to the west, where it covers the greater part of Wales, deriving from this its name, the Cambrian range. Its principal ridge stretches through Carnarvonshire from north and west, with Snowdon (3,560 feet) as the culminating point of south Great Britain; across the Bristol Channel from Wales is the Devonian range. It may be considered as commencing in the Mendip Hills of Somerset and then pursuing a southwest direction through that county and the counties of Devon and Cornwall to the Land's End, the wild and desolate tract of Dartmoor forming one of its most remarkable features (highest summit, High Willhayes, 2,039 feet). Other ranges are the Cotswold Hills, proceeding in a northeast direction from near the Mendip Hills; the Chiltern Hills taking a similar direction farther to the east and the North and South Downs running east, the latter reaching the southern coast near Beachy Head, the former reaching the southeast coast at Folkestone.

A large part of the surface of England consists of wide valleys and plains. Beginning in the north, the first valleys on the east side are those of the Coquet, Tyne and Tees; on the west the beautiful valley of the Eden, which, at first hemmed in between the Cumbrian range and Pennine Chain, gradually widens out into a plain of about 470 square miles, with the town of Carlisle in its centre. The most important of the northern plains is the Vale of York, which has an area of nearly 1,000 square miles. On the west side of the island, in south Lancashire and Cheshire, is the fertile Cheshire plain. In Wales there are no extensive plains,

the valleys generally having a narrow, rugged form favorable to romantic beauty, but not compatible with great fertility. Wales, however, by giving rise to the Severn, can justly claim part in the vale, or series of almost unrivalled vales, along which it pursues its romantic course through the counties of Montgomery, Salop, Worcester and Gloucester. Southeast of the Cotswold Hills is Salisbury plain, a large elevated plateau, of an oval shape, with a thin, chalky soil only suitable for pasture. In the southwest the only vales deserving of notice are those of Taunton in Somerset and Exeter in Devon. A large portion of the southeast may be regarded as a continuous plain, consisting of the Wealds of Sussex, Surrey and Kent, between the North and South Downs, and containing an area of about 1,000 square miles. The southeast angle of this district is occupied by the Romney marsh, an extensive level tract composed for the most part of a rich marine deposit. Extensive tracts of a similar nature are situated on the eastern coast in Yorkshire and Lincoln, where they are washed by the Humber; and in the counties which either border the Wash, or, like Northampton, Bedford, Huntingdon and Cambridge, send their drainage into it by the Nen and the Ouse.

For the climate of England see GREAT BRITAIN — GEOGRAPHICAL ENVIRONMENT.

**Rivers.**—England is well supplied with rivers, many of them of great importance to industry and commerce. Most of them carry their waters to the North Sea. If we consider the drainage as a whole, four principal river basins may be distinguished, those of the Thames, Wash and Humber belonging to the North Sea; and the Severn, belonging to the Atlantic. The basin of the Thames has its greatest length from east to west, 130 miles, and its average breadth about 50 miles, area, including the Medway, 6,100 square miles. The river itself, which is the chief of English rivers, has a length of 210 miles. The basin of the Wash consists of the subordinate basins of the Great Ouse, Nen, Welland and Witham, which all empty themselves into that estuary, and has an area computed at 5,850 square miles. The basin of the Severn consists of two distinct portions, that on the right bank, of an irregularly oval shape, and having for its principal tributaries the Teme and the Wye; and that on the left, of which the Upper Avon is the principal tributary stream. The area of the whole basin is 8,580 square miles. The next basin, that of the Humber, the largest of all, consists of the three basins of the Humber proper, the Ouse and the Trent, and its area is 9,293 square miles, being about one-sixth of the whole area of England and Wales. Other rivers unconnected with these systems are the Tyne, Wear and Tees, in the northeast; the Eden, Ribble, Mersey and Dee, in the northwest. The southern coast streams are very unimportant except for their estuaries. See THAMES.

**Areas and Population.**—The total area of England and Wales amounts to 58,340 square miles, and the population (1911 census) aggregated — England, 34,045,290; Wales, 2,025,202, making a total of 36,070,492. A later official estimate, made in 1914, placed the total at 36,960,684; while the National Register, taken in August, 1915, placed the civilian population

at 35,360,000. In 1901 England and Wales contained 78 per cent of the population of the United Kingdom; in 1911 it rose to 79.8 per cent, or four-fifths of the whole British Isles. The density of the population in England is greater than in any other European country (disregarding Monaco) except the kingdom of Saxony (829 per square mile). In 1911 it was for England alone 670 per square mile; for England and Wales, 618. In Scotland it was only 154, and Ireland 137 per square mile.

The first uniform census of the United Kingdom was taken in 1801. The growth of population in England and Wales during 264 years is shown by the following available statistics:

In 1650 (estimated)	5,450,000
1750 (probably)	6,400,000
1801 (census)	8,892,536
1841 (England)	15,002,443
1851 (together)	16,921,888
1861 "	18,954,444
1871 "	21,495,331
1881 "	24,613,926
1891 "	29,002,525
1901 "	32,526,075
1911 "	36,070,492
1914 (estimated)	36,960,684

During the 100 years (1801-1901) the population of the United Kingdom rose from 16,000,000 to 41,000,000. The 1911 census revealed 17,445,608 males and 18,624,884 females, an excess of 1,179,276 females. Men serving in the army, navy and merchant service abroad are not included in this calculation. The number of separate families in 1911 was 8,005,290, as compared with 7,036,868 in 1901. In 1914 there were 879,096 births, 37,329 illegitimate births, 294,401 marriages and 516,742 deaths. The proportion of male to female births for that year was 1,036 male to 1,000 female, while of the total estimated population 17,877,052 were males and 19,083,632 females. The following table shows the areas and population of the 40 English and 12 Welsh counties (1911):

COUNTIES (Administrative)	Area in square miles	Population
Bedfordshire	466.4	194,588
Berkshire	721.9	195,811
Buckinghamshire	743.2	219,551
Cambridgeshire	492.5	128,322
Cheshire	1,027.8	676,275
Cornwall	1,356.6	328,098
Cumberland	1,520.4	265,746
Derbyshire	1,029.5	560,013
Devonshire	2,604.9	457,331
Dorsetshire	987.9	223,266
Durham	1,014.6	929,214
Essex	1,523.2	1,061,851
Gloucestershire	1,243.3	329,014
Hampshire	1,623.5	433,566
Herefordshire	839.6	114,269
Hertfordshire	634.6	311,284
Huntingdonshire	366.0	55,577
Isle of Ely	371.9	69,752
Kent	1,554.7	1,020,965
Lancashire	1,880.2	1,739,320
Leicestershire	823.6	249,331
Lincolnshire:		
Holland	410.6	82,849
Kesteven	727.9	111,324
Lindsey	1,501.7	237,843
London	117.0	4,521,685
Middlesex	283.3	1,126,465
Monmouthshire	534.0	312,028
Norfolk	2,044.4	321,733
Northamptonshire	1,003.1	213,733
Stoke of Peterboro'	83.5	44,718
Northumberland	2,018.0	371,474
Nottinghamshire	843.4	344,194

COUNTIES (Administrative)	Area in square miles	Population
Oxfordshire	755.7	146,221
Rutlandshire	152.0	20,346
Shropshire	1,343.0	246,307
Somersetshire	1,630.3	407,304
Staffordshire	1,171.2	738,990
Suffolk	1,488.6	320,128
Surrey	758.0	676,027
Sussex	1,459.2	418,454
Warwickshire	902.3	408,227
Westmoreland	786.2	63,575
Wight, Isle of	146.9	88,186
Wiltshire	1,374.9	286,822
Worcestershire	751.0	427,026
Yorkshire:		
East Riding	859.0	154,768
North Riding	2,124.5	314,779
West Riding	2,764.2	1,584,880

Following are the 72 county boroughs, their areas and populations:

COUNTY BOROUGHS (England)	Area (square miles)	Population
Barrow-in-Furness	17.2	63,770
Bath, City of	5.3	50,721
Birkenhead	6.0	130,794
Birmingham, City of	21.0	525,833
Blackburn	12.2	133,052
Blackpool	5.6	58,371
Bolton	23.8	180,851
Bootle	3.0	69,876
Bournemouth	9.0	78,674
Bradford, City of	35.8	288,458
Brighton	3.9	131,237
Bristol, City of	27.3	357,048
Burnley	6.2	106,322
Burton-on-Trent	6.5	48,266
Rury	9.2	58,648
Canterbury, City of	6.2	24,626
Chester, City of	4.5	39,028
Coventry, City of	6.5	106,349
Croydon	14.0	169,551
Derby	8.2	123,410
Devonport	4.9	81,678
Dudley	5.5	51,079
Eastbourne	10.1	52,542
Exeter, City of	4.9	48,664
Gateshead	4.9	116,917
Gloucester, City of	3.6	50,035
Great Yarmouth	5.6	55,905
Grimsby	4.5	74,659
Halifax	21.8	101,553
Hastings	7.0	61,145
Huddersfield	18.5	107,821
Ipswich	12.7	73,932
Kingston-upon-Hull, City of	14.3	277,991
Leeds, City of	33.7	445,550
Leicester	13.4	227,222
Lincoln, City of	5.8	57,285
Liverpool, City of	26.0	746,421
Manchester, City of	33.8	714,333
Middlesbrough	4.2	104,767
Newcastle-upon-Tyne, City of	13.2	266,603
Newport (Monmouth)	7.0	83,691
Northampton	5.4	90,064
Norwich, City of	12.3	121,478
Nottingham, City of	17.1	259,904
Oldham	7.4	147,483
Oxford, City of	7.3	53,048
Plymouth	3.5	112,030
Portsmouth	9.5	231,141
Preston	6.2	117,088
Reading	9.2	75,198
Rochdale	10.1	91,428
Rotherham	9.3	62,483
St. Helens	11.4	96,551
Salford	8.1	231,357
Sheffield, City of	37.9	454,632
Smethwick	3.0	70,694
Southampton	7.2	119,012
Southport	8.0	51,643
South Shields	3.7	108,647
Stockport	8.5	108,682
Stoke-on-Trent	17.4	234,534
Sunderland	5.2	151,159
Tynemouth	6.8	58,816
Walsall	11.7	92,115
Warrington	4.7	72,166

COUNTY BOROUGH (England)	Area (square miles)	Population
West Bromwich	9.1	68,330
West Ham	7.3	289,033
West Hartlepool	4.2	63,922
Wigan	7.6	89,152
Wolverhampton	5.5	95,328
Worcester, City of	4.9	47,982
York, City of	5.8	82,282

WELSH COUNTIES (12)

Anglesey	276.0	50,928
Brecknockshire	733.2	59,287
Cardiganshire	692.5	59,879
Carmarthenshire	919.5	160,405
Carnarvonshire	571.8	125,043
Denbighshire	665.7	144,783
Flintshire	254.7	92,705
Glamorganshire	764.8	742,998
Merionethshire	659.9	45,565
Montgomeryshire	797.0	53,146
Pembrokeshire	614.0	89,960
Radnorshire	470.5	22,590

WELSH BOROUGH (3)

Cardiff, City of	9.8	182,259
Merthyr Tydfil	27.7	80,990
Swansea	8.1	114,663

The political divisions are—England, 40 counties in 231 divisions returning 231 members to Parliament; 134 cities, boroughs, etc., in 204 divisions returning 225 members; and three universities, 5 members. Total, England, 461 members. Wales, 13 counties in 22 divisions—22 members; 10 cities, boroughs, etc., in 11 divisions—12 members. Total, Wales, 34. Total parliamentary representatives, England and Wales, 495 (Scotland, 72; Ireland, 103).

**Historical Summary.**—The leading events in English history (which are treated more fully elsewhere), may be briefly summarized here for ready reference:

- B. C. 55 — First Roman invasion under Julius Caesar, led to Roman conquest and civilization
- A. D. 410 — Roman evacuation; left Britain and her earliest civilization a prey to the barbarians.
- 449 — English land in Britain; birth of feudalism and local government.
- 597 — Landing of Augustine; conversion of English to Christianity; beginning of papal domination.
- 787 — Beginning of Danish invasions; inaugurated a period of anarchy and warfare, arresting progress and preparing England for conquest by the Normans.
- 825 — Eilandune and supremacy of Wessex; union of English kingdoms under Egbert.
- 878 — Ethandune and Treaty of Wedmore; England saved from anarchy and devastation; inauguration of King Alfred's reforms.
- 1066 — Battle of Hastings; Normans conquered Saxons; introduction of Norman civilization; beginning of England's greatness.
- 1086 — Domesday book and Salisbury Oath; established feudal system, and the power of the Crown; reformed central government.
- 1095 — Crusades began; undermined feudalism; aided the rise of the middle classes; introduced Eastern civilization.
- 1100 — Charter of Liberties; basis of English liberty and of Magna Carta.
- 1106 — Tenchebrai; conquest of Normandy; beginning of colonial empire and of English power in France.
- 1170 — Invasion of Ireland; inaugurated incessant misrule and anarchy in a part of the British Empire; opened a problem not yet solved in the 20th century.
- 1215 — Magna Carta; first written law and first real guarantee of the liberty of the subject; basis of all subsequent legislation.
- 1265 — De Montfort's Parliament; first representative parliament; beginning of popular representation.
- 1295 — Model Parliament of Edward I; first free parliament; all classes completely represented.
- 1314 — Battle of Bannockburn; established Scotland's independence.

- 1322 — Commons gain a share in legislation; the middle classes begin winning their way into first place in the government.
- 1346 — Battle of Crecy; definitely plunged England into a century's struggle with France; established the supremacy of yeomen and mercenaries over feudal knights and feudal levies.
- 1349 — The "Black Death";—depopulated Europe; provoked a life and death struggle between capital and labor, culminating in the Peasants' Revolt.
- 1381 — Peasants' Revolt; revolution in the manorial system; emancipation of serfs; new era in the history of labor.
- 1399 — Deposition of Richard II and accession of Henry IV; overthrow of royal despotism; establishment of constitutional monarchy; its failure marked a century and a half of great misery.
- 1429 — Siege of Orleans; turning point in the Hundred Years' War; death-blow to English Continental Empire; caused the War of the Roses.
- 1430 — Disfranchising Act; lower middle classes deprived of their vote; no representative parliament for exactly four centuries.
- 1461 — Battle of Towton and of Mortimer's Cross; overthrow of Lancastrian rule and of the constitutional experiment; inauguration of the New Monarchy (the "benevolent despotism" of the Crown).
- 1473 — Caxton introduced printing; inaugurated the "New Learning" and the education of the masses.
- 1497 — Cabot's discovery of the American mainland; inaugurated trade with America; forerunner of British-American empire.
- 1529 — Divorce of Catherine of Aragon; Reformation set in motion.
- 1534 — Act of Supremacy; separation from Rome; King supreme head of English Church; establishment of Anglican Church.
- 1558 — Accession of Elizabeth; final victory of Protestantism; beginning of brilliant Elizabethan era and of England's supremacy in Europe.
- 1588 — Defeat of the Spanish Armada; Protestantism saved; England mistress of the seas; inaugurated great struggle between Crown and Parliament.
- 1604 — The name "Great Britain" given to England, Scotland and Wales.
- 1607 — Colonization of Virginia; began rivalry of English and French in America.
- 1628 — Petition of Right; first great victory of Parliament over Stuart despotism; ranks with Magna Carta as a bulwark of English liberties.
- 1640 — Meeting of the Long Parliament; overthrew Stuart despotism.
- 1641 — Root and Branch Bill and Grand Remonstrance; plunged England into the great Civil War; victory of Puritanism over Episcopacy.
- 1645 — Battle of Naseby; victory of Puritan army over Royalists; led to execution of Charles I.
- 1649 — Execution of Charles I.; overthrow of the Constitution, Monarchy, Church and Parliament; establishment of republic.
- 1660 — Restoration; overthrow of Puritanism; restoration of Monarchy, Church and Parliament; renewal of Stuart despotism.
- 1679 — Habeas Corpus Act; prevented arbitrary imprisonment; guaranteed to the accused a fair trial.
- 1688 — The "Glorious Revolution"; final overthrow of royal despotism; establishment of constitutional government; Bill of Rights—the third great guarantee of English liberty.
- 1693 — National Debt began; revolution in British finance; Bank of England founded (1694); security of investment.
- 1704 — Battle of Blenheim; saved England and Europe from French domination.
- 1707 — Union with Scotland; completed the union of Great Britain; new era in Scottish development.
- 1721 — Walpole Prime Minister; cabinet system; party government; inaugurated a peace policy which formed the foundation of England's future supremacy.
- 1757 — Battle of Plassey; conquest of India; saved England's Empire in the East.
- 1759 — "Annus Mirabilis"—the most wonderful year in England's history; gave her Canada; overthrew French supremacy; led to Treaty of Paris, and establishment of her great Colonial Empire.
- 1783 — Treaty of Versailles; Pitt Prime Minister; independence of New England colonies; overthrow of George III's absolutism.
- 1788 — Settlement in New South Wales; colonization of Australia, and establishment of Australasian Empire.
- 1789 — Outbreak of French Revolution; overthrow of Continental feudalism; inaugurated revolt of the oppressed; plunged Europe into great wars; produced Napoleon; arrested reform in England for 40 years.
- 1801 — Union with Ireland; Pitt's failure to solve the Irish question.
- 1805 — Trafalgar; finally established Britain's naval supremacy, and saved her from Napoleon's domination.
- 1815 — Waterloo.

- 1829 — Catholic Emancipation Act; triumph of religious toleration in England; put an end to religious hatred and persecution.
- 1832 — First Great Reform Bill; new phase in parliamentary reform; gave the franchise to the upper middle classes; added half a million voters.
- 1846 — Repeal of the Corn Laws; triumph of free trade; cheap food for the masses.
- 1854-55 — Crimean War.
- 1868 — Second Great Reform Bill; gave the franchise to the lower middle classes; added over a million voters.
- 1869 — Disestablishment of the Irish Church; gave to Ireland the religious liberty enjoyed by Great Britain; marked a new phase in the Irish question — that of reform and attempted conciliation.
- 1879 — Zulu War.
- 1882 — British supremacy in Egypt established at Tel-el-Kebir; end of the Anglo-French condominium; beginning of British conquest in North Africa.
- 1885 — Third Great Reform Bill; gave the franchise to the laboring classes; completed popular representation; added over two million voters.
- 1899 — South African War.
- 1901 — Death of Queen Victoria.
- 1910 — Death of King Edward VII.
- 1914 — Great Britain declared war on Germany.

**Redistribution Recommendations for England and Wales.**— On 4 Oct. 1917 the report of the boundary commission was published as a blue book in three volumes. The commissioners recommended the extinction of 27 English boroughs and merging them in county constituencies in order to remove the "confusion and inconvenience" caused by overlapping boundaries. It was not intended to create any new parliamentary boroughs with a population of less than 70,000, yet in several cases it would be necessary to do so owing to peculiar local conditions. According to the estimated population in 1914 (the last census was in 1911), the average population per member in the new constituencies was given as 71,005 for England and 72,099 for Wales; the two countries together, 71,078. The general effect of the scheme will be to increase the number of members for English constituencies from 461 to 485; of

GENEALOGICAL TABLE OF ENGLISH SOVEREIGNS, 975-1918

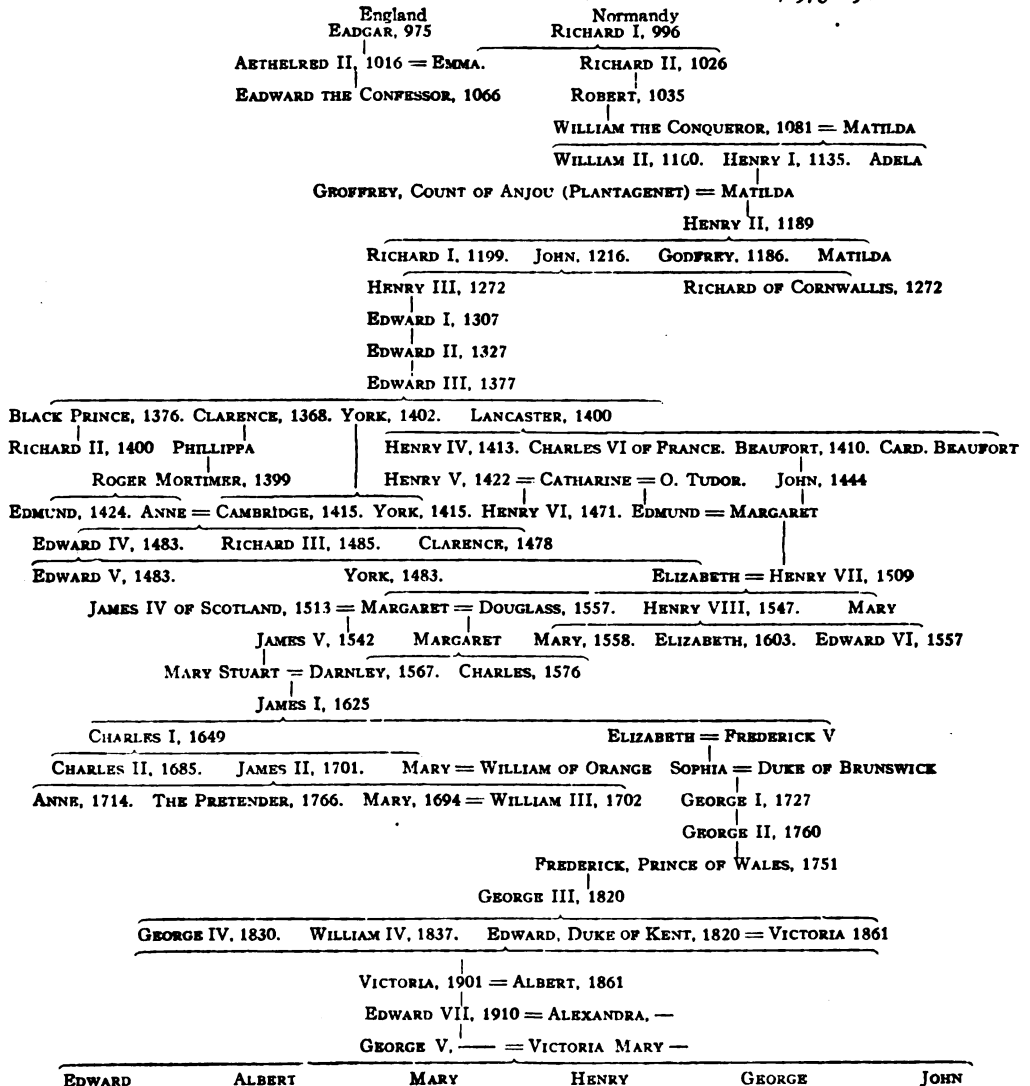

Welsh constituencies from 34 to 35; total increase for England and Wales, 25 members.

Some of the changes under the redistribution scheme are given below. Birmingham is allotted 12 members instead of 7; Bradford, 4 instead of 3; Bristol, 5 instead of 4; Kingston-upon-Hull, 4 members instead of 3; Leeds, 6, formerly 5; Leicester, 3 members, formerly 2; Liverpool, 11, formerly 9; Manchester, 10 members, formerly 6; Portsmouth, 3, formerly 2; Sheffield, 7 members, formerly 5. New boroughs created are Accrington, Barnsley, Blackpool, Bootle, Bromley, Kent, Ealing, East Ham, Eccles, Edmonton, Hornsey, Ilford, Kingston-upon-Thames, Leigh, Leyton, Morley, Nelson, Richmond, Surrey, Rossendale, Rotherham, Smethwick, Southend-on-Sea, Southport, Tottenham, Wallasey, Wallsend, Walthamstow, Willemsden, Wimbledon.

**ENGLAND'S HELICON**, an anthology of 150 poems by popular writers of the period, edited by John Bodenham in 1600. It was re-published in 1812.

**ENGLEHEART, George**, English miniature painter: b. Kew, 1752; d. 1829. He was a pupil of George Barret and Sir Joshua Reynolds. In 1773 he first exhibited at the Academy. He retired in 1813. He is reputed to have painted in all about 4,850 miniatures, mostly on ivory, but also on enamel. He was a good draughtsman and a skilful colorist. He was appointed miniature painter to George III in 1790, whom he painted 25 times. He was the most important rival of Richard Cosway for court honors. Consult Williamson and Engleheart, 'George Engleheart' (London 1902).

**ENGLER, Edmund Arthur**, American educator: b. Saint Louis, Mo., 23 Dec. 1856. He was graduated at Washington University in 1876, where he taught mathematics from 1881 to 1901. In 1901-11 he was president of the Worcester Polytechnic Institute and in 1911 returned to Washington University as secretary and treasurer. He was a member of the Washington University eclipse party to Norman, Cal., in 1889, served as chairman of the jury of the department of manufactures at the Buffalo Exposition of 1901, and chairman of the international jury on instruments of precision at the Saint Louis Exposition of 1904. He is Fellow of the American Association for the Advancement of Science and member of many other scientific societies, serving as president in 1898-1901 and again in 1912-15 of the Saint Louis Academy of Science. He is a frequent contributor to magazines on scientific subjects.

**ENGLER, Heinrich Gustav Adolf**, German botanist: b. Sagan 1844. He received his education at Breslau, held the chair of botany at Kiel in 1878-84, and at Breslau in 1884-89. In the latter year he was appointed to the chair of botany at Berlin, becoming also director of the Botanical Gardens. His work has been more or less exclusively devoted to classification and plant geography. After 1881 he edited the leading journal in this field, the *Botanische Jahrbücher*. His most remarkable publication is 'Syllabus der Pflanzenfamilien,' the classification of which has been almost universally adopted. With Prantl he issued a systematized presentation of the plant genera of the world,

entitled 'Die natürlichen Pflanzenfamilien,' and of the species, 'Das Pflanzenreich.' With Drude he prepared a detailed plant geography of the different regions under the title, 'Die Vegetation der Erde.'

**ENGLEWOOD, Colo.**, city of Arapahoe County, five miles south of Denver. It is the seat of the National Swedish Sanitarium and the Molkeray Sanitarium. The surrounding region is engaged in agriculture, dairying and stock-raising, which represent the city's principal interests. The city contains many beautiful homes, and is a favorite residential suburb of Denver, with which it is connected by trolley. Pop. 2,983.

**ENGLEWOOD, N. J.**, city, in Bergen County, near the Hudson River, on a branch of the Erie Railway, about 13 miles north of Jersey City. It lies on the long slope toward the west from the crest of the Palisades of the Hudson. It is a beautiful residential city, contains two summer homes for working girls, a hospital and a library with over 10,000 volumes. The township of Englewood was set off from the old township of Hackensack in 1871. It was incorporated as a city in 1895, but because of error under the constitution of the State it was reincorporated in 1899. While not important in manufactures the United States census for 1914 showed within the city limits 19 establishments of factory grade, employing 135 persons; 91 being wage earners receiving annually a total of \$51,000 in wages. The capital invested aggregated \$257,000, and the year's output was valued at \$321,000: of this, \$210,000 was the value added by manufacture. Pop. 11,487.

**ENGLIS, John**, American shipbuilder: b. Brooklyn, 25 Nov. 1808; d. Brooklyn, 25 Oct. 1888. He was educated in the public schools of New York and learned the shipbuilding trade there. In 1837 he went to Lake Erie where he built his first steamships. A few years later he returned to New York, opened a shipyard of his own on the East River and devoted himself to the building of steamships, a science then still in its infancy and facing many difficult problems. To the solution of these he brought a keen scientific mind and a great capacity for hard work, which soon put him into the forerank of American shipbuilders. During his long business career he built a total of 89 boats, mostly side-wheelers. Amongst them were many of the most famous boats of this period, such as the steamboats *Saint John*, *Dean Richmond*, *Daniel Drew*, *Grand Republic* and especially the Long Island Sound liner *Newport*. The last-named boat was 340 feet long and made the trip from New York to Newport in eight hours, a record which stood for many years. In 1861 he built the *Unadilla*, the first gunboat built for the United States government. Many improvements in shipbuilding were due to him. After his retirement his son and grandsons continued his shipyard.

**ENGLISCH, Joseph**, Austrian surgeon: b. Freudenthal, Austrian Silesia, 1835. He received his education at the University of Vienna and in 1871 was appointed one of the chief physicians at the Rudolfstiftung. In 1892 he was appointed to the chair of surgery at the University of Vienna. He was widely recognized as

an authority on genito-urinary diseases. His published works include 'Ueber Ovarialhernien' (1871); 'Zur Radikalbehandlung der Eingeweidebrüche' (1878); 'Ueber abnorme Lagerung des Hodens ausserhalb der Bauchhöhle' (1885); 'Ueber angeborene Penisfisteln' (1892).

**ENGLISH, Thomas Dunn**, American author: b. Philadelphia, Pa., 29 June 1819; d. Newark, N. J., 1 April 1902. He was graduated in medicine at the University of Pennsylvania in 1839. In 1842 he was admitted to the bar. From 1844-52 and 1857-59 he engaged in journalism in New York and Washington. From 1852-57 he practised medicine in what is now West Virginia. During the years 1859-79 he divided his time between New York city and Fort Lee, N. J. In the latter year he removed to Newark, N. J., where he resumed the practice of medicine. He was a member of the New Jersey State assembly in 1863-64, and of Congress in 1891-95. During all these years he was also very active in literary work. He was the author of 'Ben Bolt,' an exceedingly popular ballad (1843), which after having long fallen into obscurity was revived by its employment in Du Maurier's novel 'Trilby,' but which owed its popularity more to its sentimentality and its musical setting than to any inherent poetical merit. His published writings are 'Zephaniah Doolittle: a Poem. From the Manuscripts of Montmorency Sneerlip Snags, Esq.' (Philadelphia 1838); 'Walter Woolfe' 1842); '1844; or, the Power of the "S.F." A Tale'; 'Developing the Secret Action of Parties During the Presidential Campaign of 1844' (New York 1847); together with C. G. Foster, 'The French Revolution of 1848, etc.' (Philadelphia 1848); 'Ambrose Fecit, or, the Peer and the Printer' (New York 1867); 'American Ballads' (New York 1880); 'The Boy's Book of Battle-Lyrics' (New York 1885); 'Jacob Schuyler's Millions' (New York 1886); 'The Rules of Order Governing Public Meetings, etc.' (under the pseud. F. M. Payne, New York 1887); 'Old Glory: A Song' (1895); 'Fairy Stories and Wonder Tales' (New York 1897); 'The Little Giant, the Big Dwarf and Two Other Wonder Tales, etc.' (Chicago 1904). During the period of his New York residence he also wrote about 20 plays for Palmo's Opera House, later Burton's Theatre, on Chambers street, New York, of which only one, 'The Mormons; or, Life at Salt Lake City, A Drama in Three Acts,' has been published (New York 1858). Consult Noll, A. H., 'Thomas Dunn English' (in *Midland Monthly*, Vol. VII, p. 3, Des Moines 1897).

**ENGLISH, William Hayden**, American capitalist: b. Lexington, Ind., 27 Aug. 1822; d. Indianapolis, Ind., 7 Feb. 1896. He was educated at Hanover College, Indiana, and admitted to the bar in 1840. However, he soon became interested in politics, gave up the practice of law, and successively held various local, State and Federal positions. In 1851 he was elected to the Indiana State legislature where he served as speaker. He was elected to Congress in 1852 and served there through four consecutive terms. As a member of the Committee on Territories, in opposition to his own party, he worked against the admission of Kansas to the Union. He reported from the Com-

mittee of Conference what was known as the "English bill," in which it was urged that the question of admission be referred back to the people of Kansas according to the provision of the Lecompton constitution. This was adopted and the people voted against admission. He strongly opposed secession, and warned Southern Congressmen that the North would never countenance such a policy. He also served as regent of the Smithsonian Institution for eight years. He finally refused the offer for a re-nomination for a fifth term in Congress and in 1863 removed to Indianapolis where he founded the First National Bank and soon made a reputation for himself as a banker. Though not taking an active part in the Civil War, he was an ardent supporter of the Union. He continued his interest in politics, and, in 1880, was unanimously nominated by the Democratic party for the office of Vice-President on the unsuccessful ticket with General Hancock against Garfield and Arthur. He was president of the Indiana Historical Society, a number of whose publications were financed by him. He also published 'Conquest of the Country Northwest of the River Ohio, 1778-83, and Life of General G. R. Clark' (2 vols., Indianapolis 1896). Consult Forney, J. W., 'Life and Military Career of W. S. Hancock, etc.' (Philadelphia 1890); Keyser, C. S., 'The Life of W. H. English' (Philadelphia 1880).

**ENGLISH ARCHITECTURE.** The earliest architecture of England (not including the megalithic remains at Stonehenge, Avebury, etc., whose date and history are still in controversy and which can hardly be classed as architecture) dates from the Roman occupation, which has left many remains of walls, villas and baths (Bath, Silchester, etc.), but hardly more than the foundations of these. Indeed, there is but little left of any architecture previous to the Norman Conquest (1066 A.D.), for the active building of churches and monasteries which followed involved the demolition of most of the earlier Christian or "Saxon" edifices. A few walls, crypts and fragments show that they were without exception rudely built, with little of architectural elegance in design or decoration. The tower of Earl's Barton is the most noted of these remains.

Following the Conquest, there began under the Norman kings a remarkable activity in building, especially of abbeys and castles. The imported Norman style, itself a provincial phase of the French Romanesque, was modified in English hands, developed into the Anglo-Norman, and applied in the building of great monastic churches, many of which surpassed in size those of France or Italy. This style was marked by its great massiveness; the use of the round arch of stepped section; huge piers sometimes round, sometimes clustered; square lantern-towers at the crossing of nave and transept; timber ceilings in preference to vaulting for the high central aisle; and restricted but bold decoration in which the zig-zag is the most frequent motive. Interlaced arches frequently appear as a wall decoration. The original abbey-cathedral of Canterbury, St. Alban's abbey, Romsey abbey, Ely and Peterboro' cathedrals, Winchester, Southwell, Durham, Norwich, Gloucester and Hereford cathedrals, the church of Christchurch, Saint Bar-

tholomew's at London, the Tower of London with its Saint John's chapel, and many feudal castles belong to this style, which lasted from 1070 to 1200. Most of the above churches were in part, Canterbury almost wholly, rebuilt in the following centuries.

The Anglo-Norman style passed away with the introduction from France of the Gothic style (see *GOthic ARCHITECTURE*) in the rebuilding of the choir of Canterbury Cathedral destroyed by fire in 1174. The pointed arch had been used occasionally before this date in England, but from about 1190 its use became the general rule, and with it the English adopted the ribbed vault and traceried window and less universally the flying arch and buttress. The new style they developed on independent lines, retaining more of the early massiveness than did the French, with less display of the structural framework in stone. The English cathedrals of 1190 to 1350 are longer, lower and narrower than the French, less ornate externally, more ornate internally, having often two transepts, square east ends in place of apses and apsidal chapels, and with west fronts often forming a screen of picturesque design instead of a logical expression of the form of that end of the church. As there were many cathedrals which were abbey-churches as well, the practice became general of grouping with them cloisters, chapter-houses, libraries and residences for the clergy. Nearly all the cathedrals have great square towers at the crossing, forming internal lanterns; at Ely this takes the form of a superb octagon as wide as the three aisles together. But one cathedral was built continuously in one style from end to end,—Salisbury (1220-58); Lichfield Cathedral and Westminster Abbey present internally a fairly uniform style, although their building covered in both cases a long period; most of the cathedrals were so often rebuilt in one or another part at different periods that they exhibit clearly the changes of style from one century to another. It is customary to distinguish these different phases and periods by names derived from the window designs, e.g., the *Lancet* (or Early English), 1174-1250; the *Decorated* (subdivided into "geometric" and "Curvilinear"), 1250-1375; and the *Perpendicular*, 1375-1500 or 1520. During these 346 years the vaulting was developed by the multiplying of the main and subordinate ribs into the extremely ornate form seen in Henry VII's Chapel at Westminster and other late works, and known as *fan-vaulting*. The English were consummate workers in wood, and many of the larger parish and collegiate churches and secular halls have timber ceilings with "hammer-beam" trusses of extraordinary beauty, instead of stone vaults. Many of the larger parish churches are unequaled elsewhere except by the foreign cathedrals. Among the most important of the predominantly Gothic cathedrals are Canterbury, Lincoln, Salisbury, Ely, York, Winchester; of the second rank, Wells, Lichfield, Exeter and Gloucester may be named; among the parish churches Boston, Saint Michael's (Coventry), Saint Mary-Redcliffe at Bristol, and Patrington; and among abbey-churches Westminster, Sherborne and Beverley.

During the 14th and 15th centuries secular architecture was developed in new lines in the

great universities and schools, and in vast manorial residences and palaces; to this phase the name of *Tudor architecture* is often given. Under Henry VIII (1507-47) artists from Italy, Germany, Holland and Flanders were imported, by whose works the decorative details of Renaissance art were made known to the English; but the Renaissance taste made slow progress in architecture, even in the manor houses of the wealthy, which continued to display the square mullioned windows, battlemented parapets and irregular plans of the Tudor Gothic period. Under Elizabeth (1558-1603) and James I (1603-25) the use of Renaissance forms steadily increased—round arches, the classic "orders," openwork balustrades and a peculiar fashion of flat relief-ornament, called "strapwork" and derived from Germany, became more and more frequent ("Elizabethan" and "Jacobean" styles). This prepared the way for the introduction of a more purely Italian or classic style by Inigo Jones under James I and Charles I, and for its culmination in Saint Paul's Cathedral (q.v.) by the great Sir Christopher Wren (q.v.), whose 53 churches built after the Great Fire of 1666, and his works at Hampton Court, Greenwich, Oxford and Cambridge firmly established the style. It continued to be used throughout the 18th century and was the parent style of our own "Colonial" or Georgian style (see *ARCHITECTURE—UNITED STATES*). The 19th century was marked by attempts, partially successful, to revive the Greek and Gothic styles in modern work; but, except in church architecture, the tendency of English design has since 1880 been toward Renaissance forms very freely adopted. The most notable example of the Gothic Revival is the Houses of Parliament by Barry (1835-50). The best work of the present-day architects of England is in domestic architecture, in which, on the whole, they are unequaled or at least unsurpassed. In the design of rural buildings, of small cottages, of garden suburbs and of country churches they especially excel.

**Bibliography.**—The literature of English architecture is enormous in volume. Only a few leading works can be mentioned. On *mediæval architecture* the works of Sir T. G. Jackson, E. S. Prior and F. Bond, and the earlier works, now somewhat out of date, of Rickman, Pugin, Britton, Parker, etc.; also Moore, C., 'Mediæval Church Architecture of England.' On the *Renaissance developments*: Blomfield, R., 'A Short History of Renaissance Architecture in England'; Gotch and Brown, 'Architecture of the Renaissance in England'; Richardson, C. J., 'Monuments of Classic Architecture in Great Britain.' For the more recent developments one must consult the architectural periodicals. There is no single work devoted to the work of the last 50 years.

A. D. F. HAMLIN,  
*Professor of Architecture, Columbia University.*

**ENGLISH CHANNEL**, or **THE CHANNEL** (Rom. *Mare Britannicus*, French *La Manche*), an arm of the Atlantic Ocean extending into the west coast of Europe to the Strait of Dover, by which it is connected with the North Sea. The land bodies separated by this channel are England and France. Its

length from the Strait of Dover to the Atlantic Ocean is about 350 miles; its greatest breadth, from Saint Malo, in France, to Sidmouth, in England, is 140 miles; its narrowest width, called the Strait of Dover, is about 20 miles. At its juncture with the Atlantic Ocean it is about 100 miles wide. Its total area is about 30,000 square miles. The average depth of the western half is about 300 feet, the maximum about 500. In the eastern half the average is only 200, and in the Strait of Dover the depth varies from 6 to 120 feet. The length of the north coastal line, from Land's End to Dover, is 390 miles; and of the south coastal line from Calais to Ushant is 570 miles. Some of the largest indentations on the coast of England are the bays of Falmouth, Plymouth, Lyme, Weymouth, Spithead and The Solent. On the coast of France are Baie de la Seine, Baie de Saint Brieu and Baie de Mont Saint Michel. The principal islands in the Channel are: Isle of Wight, Channel Islands and several other islands near the coast of France; Scilly Isles and Ushant at the entrance. The most important ports are: on the English coast, Falmouth, Plymouth, Southampton, Portsmouth, Brighton, Folkestone, Andover; on the French coast, Cherbourg, Le Havre, Dieppe, Boulogne and Calais. Many of these and many other towns and villages on both coasts have become famous as watering places and seaside resorts. The tides, coming both from the Atlantic Ocean and from the North Sea, possess many peculiarities and make navigation difficult at times. There are many lighthouses and light ships, the most famous of which, perhaps, is the Eddystone Light off Plymouth. The prevalent winds are most westerly. Gales are frequent, especially between October and January. Fog and thick weather are also frequent occurrences throughout the entire year. The water, most of the time, is rough and makes travel in the Channel as a rule a most unpleasant experience. This has been a chief factor in bringing forth many plans for a direct non-water connection between England and France, either by means of a bridge or a tunnel. Of the former the most important has been a project put forward by the famous French engineering firm, Schneider & Co., Le Creusot, in conjunction with English and French engineers, which provided for a bridge 24 miles long with 120 piers and permitting the passage of ships beneath it. The tunnel project was found feasible from an engineering point of view, and preliminary shafts and headways were started on both coasts. On the English side the shaft at Shakespeare's Cliff, Dover, is 164 feet deep, and a driftway, 7 feet in diameter at an inclination of 1 in 72, extends eastward under the Channel for 2,300 yards. During the borings valuable coal beds were discovered. So far, however, neither the bridge nor the tunnel projects have been able to get the final approval of either the English or the French government. Many historic naval engagements have been fought in the Channel. Consult Channel Bridge and Railway Co., 'Pont sur la Manche' (Paris 1890); Great Britain, Admiralty, Hydrographic Department, 'The Channel Pilot' (2 parts. London); Hawkshaw, J. C., 'The English Channel Tunnel and Its Early History' (in *Scientific American Supplement*,

Vol. LXXVIII, pp. 18 and 34, New York 1914); Hersent, H., and Sir John Fowler, and Benj. Baker, 'Pont sur la Manche, Avant-Projets de MM. Schneider et Cie., etc.' (Paris 1889); Jukes-Brown, A. J., 'Geographical Evolution of the English Channel' (in *Contemporary Review*, Vol. LXI, p. 855, London 1892); Mackinder, H. J., 'Britain and the British Seas' (New York 1902); McMullen, R. T., 'Down Channel' (London 1893); Perkins, W. T., ed., 'Channel Tunnel: Reports by British and French Engineers' (London 1907); Spethmann, H., 'Der Kanal mit seinen Küsten und Flottenstützpunkten' (in *Kreisgeographische Zeitbilder*, Part 3, Leipzig 1915).

**ENGLISH CHRONICLES.** The writing of English chronicles begins with the 'Anglo-Saxon Chronicle,' the earliest English history written in the English language, and the earliest vernacular record of national events in modern Europe. The 'Chronicle' opens with the Christian era, combining in its earlier parts records of Roman, Christian and British events. It rapidly becomes strictly national, carrying the record of English history forward to a considerable period after the Norman Conquest. It treats in general of the affairs of all the English-speaking peoples in Great Britain, and as one of the first attempts at an expression of coherent national life and as a trustworthy source of information concerning the language, history and social manners and customs of the Anglo-Saxon period, the importance of the 'Chronicle' can hardly be overestimated. Although the work itself does not mention the name of its author, there is strong evidence to show that in its original form it was undertaken at the suggestion of King Alfred and was in part actually written by him. From this original form, now no longer extant, copies were made and carried to different sections of England, where they served as foundations of what, from that time, became separate and independent chronicles. Seven of these local chronicles, with a fragment of an eighth, have come down to us. The date at which the original parent version was made was about 892, and the place was probably Winchester, the capital of the West-Saxon kingdom. The form in which the 'Chronicle' is written is that of a book of annals, the entry for each year containing usually the record of but a single occurrence. For the early years the records, derived chiefly from literary sources, are brief and colorless, but in the later parts, particularly in the accounts of the Danish wars, when the narrative becomes more nearly contemporary with the time of the compilation of the work, they become more detailed and vigorous. At no time, however, is there an attempt to write a philosophic history, to point out the causes or the trend of events. This is in accord with the main purpose of chronicle writing, which is merely to keep the events of history in their right chronological perspective, the details centering about these events being largely entrusted to oral tradition. This annalistic purpose of the 'Chronicle' determined also its mechanical form. The scribe's method was to rule off a number of pages as though preparing a journal in which the entries were to be made by years instead of days. Each year was thus given a blank space opposite its number sufficient usu-



ally for only a few lines. The scribe then inserted whatever annals he had been able to collect, leaving the spaces for which he had no materials to be filled in later when new material should become available. This method of chronicle writing remained long in use in England, being followed by Capgrave as late as the 15th century.

Although no single model or source for the 'Chronicle' is known, there were in existence in Alfred's time a number of Latin works which were of help in its first compilation. Of these the most important were Bede's 'Historia Ecclesiastica Gentis Anglorum,' finished in 731; Bede's 'De temporum ratione,' a chronological essay containing a short epitome of the history of the world from Adam to 729 A.D.; Orosius' 'Universal History' ('Pauli Orosii Historiarum Adversum Paganos Libri VII'); and doubtless many records of national events preserved in local monastic libraries. But the 'Chronicle' was an original work in that it strove to record the life of a nation. Just as the codes of laws systematized the customs and rules of living of the people, so the 'Chronicle' fixed for them the ever-receding events of their history.

From the period of its original composition to the middle of the 11th century, the 'Anglo-Saxon Chronicle' established the form for all historical writing in England. Although we now know only seven, with the fragmentary eighth, versions of the 'Chronicle,' the number in the Anglo-Saxon period must have been much greater, copies being probably kept at every important monastery and town. Toward the end of the Anglo-Saxon period, however, the 'Chronicle' tends to become less and less national and more and more ecclesiastical in its character. In harmony with this change the language of chronicle writing changed also to Latin. The use of Anglo-Saxon as late as 1154, the date of the latest entry in that tongue, appears only in one version, and is plainly due to reasons of respect for the traditional language of the 'Chronicle.' To take the place of the English annals of the 'Chronicle,' new histories began to be written in Latin. The earliest of these was that of Ethelwerd; others from the beginning of the 12th to the 14th century were the histories of Symeon of Durham, Florence of Worcester, William of Malmesbury, Henry of Huntingdon, Roger of Hoveden, Matthew of Paris, Matthew of Westminster, Roger of Wendover, and Ralph Higden, whose 'Polychronicon' was the "standard work of general history in the 14th and 15th centuries" (Babington, ed. of 'Higden' in the Rolls Series, p. xliii). All of these Latin histories derived much of their material either directly or indirectly from the 'Anglo-Saxon Chronicle.' In the Middle English period several metrical histories were written in English, the 'Brut' of Layamon, the chronicles of Robert of Gloucester and of Robert Manning of Brunne; but these are better characterized as historical romances than as attempts at veracious history. The writing of prose histories in English begins again with Trevisa's translation of Higden's 'Polychronicon,' made in 1387, and with John Capgrave's original chronicle, written about the middle of the following century. The tone of Capgrave's work, as compared with the 'Anglo-Saxon Chronicle,' is extremely naive. The

writers of the 'Chronicle' had a most rigid sense of historical fact, but the work of Capgrave and his contemporaries is marked by an altogether uncritical and credulous mingling of legend and history. As a result, however, of this infusion of the romantic spirit into historical writing, the older annalistic method gave way to one in which greater attention was paid to a consecutive narrative interest, after the manner of modern historical writing. The national awakening accompanying the reigns of Henry VIII and Elizabeth resulted in a renewed interest in the writing of these history-chronicles. In 1516 appeared Fabyan's 'New Chronicles of England and France'; in 1562 Grafton's 'Abridgment of the Chronicles of England'; in 1565 Stowe's 'Summarie of Englyshe Chronicles'; and in 1578, the most important of the Elizabethan chronicles because of the use made of it by Shakespeare, 'The Chronicles of England, Scotland and Ireland,' written by Holinshed with the assistance of several others. The term chronicle continued to be used in the titles of historical works to the end of the 17th century, as in Sir Roger de Coverley's favorite book, Baker's 'Chronicle of the Kings of England,' 1643; by this time, however, the naive annalistic chronicle had largely given way to the more philosophical treatment of events which is designated by the name of history.

**Bibliography.**—For general bibliography, consult Gross, 'Sources and Literature of English History from the Earliest Times to about 1485' (1900). Editions of most of the chronicles will be found in the Rolls Series; the best edition of the 'Anglo-Saxon Chronicle' is that of Earle and Plummer (Oxford 1892-99). The literary significance of the chronicles is discussed by Schofield, 'English Literature from the Norman Conquest to Chaucer' (pp. 29-46); and by Schelling, 'English Chronicle Plays' (New York 1902). Consult also 'Cambridge History of English Literature' (Vol. I, chap. 7, 1907).

GEORGE P. KRAPP,

*Professor of English, Columbia University.*

**ENGLISH COLLEGE AT ROME**, an ancient institute in the papal city, erroneously supposed to have been founded, according to statements of mediæval chroniclers, about 816. In reality it dates from the middle of the 14th century, when the Hospice of Saint Thomas of Canterbury,—which owed its establishment to the jubilees—was founded and liberally endowed for the entertainment of Englishmen visiting the Holy See. In the time of Henry VIII refugees from England were harbored in the hostel. In the reign of Elizabeth the institution was transformed into a seminary for the education of aspirants to the priesthood who proposed to serve in the English mission, which they entered with pretty fair assurance of the martyr's crown. This seminary was placed under Jesuit control, the date of appointment of the first rector—the real birthday of the college—being 23 April 1579. Between 1578 and 1647, 40 of the alumni of the institution, serving as missionary priests in England, were executed for the high treason of exercising the Catholic ministry contrary to the laws of the realm; and when Saint Philip Neri, founder of the Congregation of the Oratorians, met any of the young English ecclesiastics in

the streets of Rome, his invariable salutation was *Avete flores martyrum* — "Hail flower of the martyrs." The college was plundered and wrecked by the French republican army 1798 and its resources dissipated; it was resuscitated 1818; its president from 1831 to 1846 was Nicholas Wiseman, afterward first archbishop of Westminster, and cardinal.

**ENGLISH CONSTITUTION.** See GREAT BRITAIN — HISTORY; PARLIAMENT.

**ENGLISH COURTS.** See COURT.

**ENGLISH FURNITURE.** See FURNITURE, MIDDLE-AGE.

**ENGLISH HARBOR,** a harbor on the southern coast of Antigua (q.v.), one of the Leeward Islands. It is the site of a British naval station, which from its location is one of the important British possessions in the West Indies. Consult Oliver, V. L., 'The History of the Island of Antigua' (3 vols., London 1894-99).

**ENGLISH LACQUERWORK.** See LACQUERS AND LACQUERWORK.

**ENGLISH LAND.** See PALE, THE.

**ENGLISH LANGUAGE.** The English language is a direct development of the Anglo-Saxon, a circumstance which makes it questionable whether the latter speech ought to be distinguished by a separate name. But although a direct development of the Anglo-Saxon, it is not a development which has been allowed to take place regularly and gradually, as the result merely of internal causes. One important external influence was brought to bear on the original form of our language, which had the double effect, first, of producing a much more sudden and complete modification of the grammatical structure than could have taken place if the language had grown up independently of foreign influences; and secondly, of giving a composite character to the vocabulary of the language by the introduction of a large number of foreign words. This external influence was the Norman Conquest, in consequence of which a new language, the Norman-French, came to be spoken in England by those who had made themselves the masters of the country, and who formed, therefore, almost the only class that had leisure and opportunity for literary pursuits. The immediate result of the Norman Conquest (1066) was thus that the language of the Normans came to be the chief literary language of England (except where Latin was used), and that the Anglo-Saxon was reduced to a very subordinate place. When the latter language again comes into notice as a written language a great change is seen to have been wrought in it. Before the Conquest it was a very highly inflected, or what is called a synthetic language, that is, one in which the substantives, adjectives, verbs and articles are subject to numerous modifications, each of which expresses a modification of the root-meaning of the word, or shows the relation of the word to the other words in the sentence. During the period when Anglo-Saxon ceased to a great extent to be a written language these inflections dropped off; and when it re-emerges as a written language about the end of the 12th century it is no longer synthetic, but analytic, that is, prepositions and auxiliaries are now used instead of inflectional prefixes and terminations to express the various

modifications of the idea contained in any word, and the relations of the words in a sentence to one another. At this period, however, the language still continued to be essentially homogeneous in respect of its vocabulary: the Norman words that occur are so rare that they need not be taken into account. And it was natural that it should be so, for the Saxon language was still confined to the Saxon inhabitants of the country; and those who wrote in it addressed themselves only to that portion of the community, and accordingly had no occasion to use any word of Norman origin. This state of matters lasted till about the middle of the 13th century, which is the period at which English proper is usually regarded as having begun to be spoken and written. By this time the Normans began to experience the inconvenience of not being acquainted with the language of the people among whom they dwelt, and in learning to speak and write it they very naturally used a large number of Norman words, and these words were adopted by all such writers belonging to the subject race as wished to make themselves understood by Normans as well as by Saxon readers. A very rapid mixing of the two languages thus took place, and a second important change was wrought in the English language. It is no longer homogeneous in its vocabulary, but contains a large admixture of foreign words.

The whole of what precedes may be shortly summarized thus: From 450 to 1066 the language spoken in England was the so-called Anglo-Saxon, a dialect of Low German, very highly inflected. From 1066 to 1250 two languages were spoken in England, Anglo-Saxon and Norman-French, by two different sections of the population occupying different political positions. During this period the grammatical structure of the former language began to be broken up, chiefly owing to its being disused for literary purposes; and toward the end of the period we find a few works written in a language resembling the English of our day in grammar, but differing from it by the homogeneity of its vocabulary. Finally, about 1250 the two languages begin to mingle and form one intelligible to the whole population, Normans as well as Saxons. This is what is usually called English proper. English is thus seen to be a composite language, deriving part of its stock of words from a German source, and part from a Latin source, Norman-French being in the main merely a modified form of Latin.

The changes that have taken place in the English language subsequently to 1250 are by no means as striking as those which took place in the transitional period between 1066 and 1250. Some few inflections which the English of the 13th and 14th centuries still retained have now been dropped, but the chief change which the language has experienced consists in its gradual growth and expansion in obedience to the requirements of advancing science, more complicated social relations, and increased subtlety of thought. This growth has been going on at all times, but there are some periods which may be pointed out as more remarkable than others for the rapidity with which it proceeded. Such a period was the end of the 16th and the beginning of the 17th century, the period of the Reformation and following the revival of learn-

ing, when numerous words of Latin origin were introduced by scholars directly from that language, instead of through the French, the channel through which most of the Latin words previously found in the language had come. Another such period is the present, when the rapid growth of the sciences already existing, and the creation of new sciences, have caused whole groups of words to be introduced, chiefly from the Greek.

It would scarcely be in place here to discuss the various excellencies and defects of the English as compared with other languages, but we may mention the following as among the qualities which the English language is generally allowed to possess. 1. Strength and expressiveness, adapting it admirably for poetical composition. 2. Copiousness, enhanced as shown under assimilation, by the extraordinary receptivity of the language, that is, its capacity for adopting new words from all sources, and of naturalizing them at once, so that they may be treated without any appearance of strangeness entirely as native English words. 3. Simplicity in form and construction. 4. Great flexibility, or adaptability to all kinds of composition, the grave and gay, the impassioned and calm, forcible and tender, sublime and ludicrous. 5. Power of assimilation, words being readily adapted from other languages, Italy, France, Spain, Holland and distinctive terms originating in the American continent, all contributing to its rich and full expressiveness. The influence of English colonizing is seen in words borrowed from India, South Africa and other colonies.

In connection with the subject of the English language, we may here further observe, that England and the United States offer the first instance in history of two great, independent and active nations having a common language, but situated at a great distance from each other, and daily developing new and characteristic features. These relations must, sooner or later, exert a powerful influence upon the common language, for no language is so stable as not to undergo continual changes, if spoken by a people in the full vigor of social and political life. This state of things has already produced some effect on the English language. The most material difference, probably, has been in the pronunciation of the language, which, however important in our daily conversation, is of secondary importance in relation to the literature and written language of the two countries. It has often been observed by English travelers and others that the pronunciation of the United States is far more uniform than that of England; and so nearly alike everywhere, that the people of any one town or district are perfectly understood in every other part of the country, which is not true of the lower ranks of England. When considered more minutely, however, there has for a long time existed a marked distinction between the pronunciation of the New England and Southern States. Only in New England States is there what may be termed a distinctive dialect. It is noted by visitors to the United States, especially to New England, that many words and turns of expressions, familiar to the England of Shakespeare, and which in their country of origin have either become obsolete or degraded into provincialisms, are living a full and vigorous life on this side of the Atlantic. The orthography of the Eng-

lish language has undergone no material change in America, it being the general inclination to follow that of the best English writers of the age. Under the inspiration of the Simplified Spelling Board, President Roosevelt in August 1906 authorized the adoption by the public printer of about 300 amended spellings; but so great was the storm of criticism that the order was withdrawn except in so far as related to the correspondence of the White House.

The English language may be divided into five periods:

1. First Period 450-1100 A.D.
2. Second Period 1100-1250 A.D.
3. Third Period 1250-1350 A.D.
4. Fourth Period 1350-1460 A.D.
5. Fifth Period 1460 A.D.—the present day.

In the first period (called also Anglo-Saxon or Old English), the language was inflectional; in the second it began to show a tendency to become analytic, the tendency increasing till in the fourth period inflections had virtually disappeared. Before the Norman Conquest there were two dialects in English, a southern and a northern, the former of which was the literary language. After the Conquest dialects became much more marked, so that we can distinguish three great varieties, the northern, the midland, and the southern, distinguished from each other by various grammatical differences. The midland dialect—or rather the subdivision known as the east midland—was that most widely spread, and it ultimately became the standard language, a result principally due to the influence of Chaucer, and in a less degree of Wyclif, Gower and others. See DIALECT; LANGUAGE, SCIENCE OF.

**ENGLISH LITERATURE.** The Norman Conquest made a great change in the development of an English literature, as in all other forms of English life. Conditions were at first most unfavorable: the English language might be used by any who pleased, but the clergy naturally used Latin, and people of any position French, or Anglo-Norman, as it is commonly called. For three centuries, therefore, we do not find in English any striking original work, anything to compare in interest with the Skaldic poetry and the Sagas in Iceland, with the French romances and fabliaux, with the German epic and courtly poetry. During these centuries, however, we do find in England what is in its way most interesting, namely, a singularly rich representation of the different phases of mediæval thought. We may conveniently begin with the work connected with the older order of things. The 'Anglo-Saxon Chronicle' was still kept up at Worcester and at Peterborough. Of these the former is preserved only as far as 1079; the latter is a much later work; in 1121 the whole chronicle was rewritten and then carried on to 1154, being something more than a mere set of annals, with a distinct character of its own. After this, beginning indeed before, comes a stately series of Latin chronicles, though in English we find only chronicles in verse. Layamon's 'Brut' (c. 1200, after the Anglo-Norman of Wace, which itself is a paraphrase of Geoffrey of Monmouth) is most interesting as language, literature and legend, giving, among other things, the introduction of King Arthur to English readers. Much later are the chronicles of Robert of Gloucester (c. 1300) and Robert of

Brunne (1330). Layamon is hardly as much history as romance. Of this latter almost everything is from French, Scandinavian or Celtic sources: there is little native English either in form or substance. 'King Horn' (c. 1250) and 'Havelock the Dane' (c. 1275) probably go back to Scandinavian originals, though they are still regarded by some as English legend material: more purely national are the stories of 'Bevis of Hampton' (c. 1275) and of 'Guy of Warwick' (c. 1300), though the versions preserved are probably from Anglo-Norman originals. Renderings of Continental romances are numberless, beginning about 1250 with the Alexander story and going on with the tale of Troy and stories of King Arthur, the Round Table and the Holy Grail, where the material is partly Celtic, giving even some of the legends of Charlemagne, and many minor stories, as 'Floris and Blancheflor,' 'Amis and Amilon,' 'Sir Tristram.' Somewhat later (1300), and less fully, come versions of the fabliaux, 'Dame Siriz,' 'Reynard the Fox,' the 'Land of Cokayne,' the 'Lay of the Ash.' About this time appear the great mediæval collections of stories, the 'Seven Sages' and the 'Gesta Romanorum,' which latter, though in Latin, was collected in England. Beside all this epic and narrative material there is a smaller lyric element; oftenest anonymous, like 'Sumer is ycumen in' (c. 1250), 'Winter wakeneth all my care,' and other love songs, as well as many political songs, among which are the patriotic poems of Lawrence Minot (c. 1325). But generally where it is not narrative, the Middle English poetry is didactic: the so-called Proverbs of Alfred, dating from the 12th century and preserved in several versions, may have old material and certainly keep something of the old alliterative form, though there is also the Norman element of verse. And as the Anglo-Saxon priestly writers used alliteration in their didactic prose, so now much of the religious literature is put into rhyme, a fashion of the Norman. The 'Poema Morale' (1200) is a sermon in verse, though now and then with a personal element and there are many other shorter homilies. A common form is the dialogue; the 'Debate of the Body and the Soul' is known in various forms (1200 and after), the dialogue between 'Mary and the Cross,' and others including, in lighter mood from a French source, the 'Owl and the Nightingale' (1220), a poem full of popular wisdom in which the gay and the gloomy views of life are championed respectively by the two birds who refer the dispute to Master Nicholas of Guilford, generally taken as the author. Less original in substance are the versions of Scripture of which the 'Ormulum,' a metrical paraphrase of the Gospels by Orm of Lincolnshire (1220) is most important for linguistic reasons, preserved in an autograph copy (probably) with an individual system of phonetic spelling. Versions of Genesis and Exodus (c. 1225) are also to be mentioned, while much later in the north (1320) 'Cursor Mundi' reviews the whole extent of history from the creation to the day of judgment. Lives of the saints there were also, especially of Saints Katherine, Margaret and Juliana, and much devotional poetry, some lyric, like the 'Wohung of oure Loverde' (c. 1225), and others, some didactic, like 'Hali Meidenheid' (c. 1250). There are also certain larger

religious treatises: the 'Ancren Riwele' (1225), a prose work of considerable merit, giving the conditions of convent rule, and in the early part of the 14th century, three books on holy living, the 'Prick of Conscience,' by Richard Rolle of Hampole; the 'Ayenbite of Inwit,' by Dan Michael of Northgate and 'Handlyng Synne,' by Robert of Brunne, the two latter from the French. Also to be noted is the very characteristic 'Bestiary' (1225), a compilation of the mediæval speculation on natural history. Such are the main elements of Middle English literature before 1350, although the number of particular works is far greater. As is common in mediæval literature the language is dialectic: no one dialect gains entire primacy till much later, although by this time the East Midland has become the most important. The second half of the 14th century was a period of great literary activity. England had been long separate from Normandy, and the English language, like the English people, had digested its different elements into an organic combination. Literature now becomes more literary. The old forms were now only to some degree preserved: Trevisa translated the 'Polychronicon' of Higden (c. 1387); Barbour in the north wrote a rhymed chronicle of Bruce (c. 1375). There are numbers of romances from the French. But didactic or allegoric poetry appears in forms which though not new have yet a certain original character. There are two great poets: one of name unknown, the author of the 'Pearl,' 'Gawain and the Green Knight,' 'Cleanness,' and 'Patience,' the other William Langland (as is most commonly thought), the author of the 'Vision Concerning Piers the Ploughman.' Fine as is their work, it is outshone by the genius of Chaucer, who gathered up and summarized the spirit of the century and whose influence was carried through the century following by companions or followers of whom the most noteworthy were Gower, Hoccleve and Lydgate. The epoch was also illuminated by Wiclif's great translation of the Bible (c. 1382). Two more popular forms of literature must be mentioned, as beginning lines of literary development still important. The ballads of Robin Hood probably go back to this period, while many of the Scotch ballads are older. The four cycles of mystery plays, those of Coventry, Chester, Wakefield (Towneley plays) and York, belong to the earlier part of the century. One remarkable book comes in no category, the 'Voiage and Travaile of Sir John Mandeville,' widely spread in England, and, though a translation, a monument of noteworthy prose. The 15th century was a period of bloody civil strife, and in literature a period of great dearth. Little can be mentioned in a summary. Sir Thomas Malory closed the period of the romances of chivalry by the 'Morte d'Arthur' (c. 1475), a collection to which he gave organic form and unity. The book was first printed (1585) at the press of Caxton, himself a writer and compiler. Some prose treatises are noteworthy, in religion Pecock's 'Repressor of Over-much Blaming of the Clergy' (c. 1450); in politics, Fortescue's 'Monarchy' (c. 1425), while of lighter interest is the treatise on 'Hawking' by Dame Juliana Berners (c. 1425), and the everyday 'Paston Letters' which belong to literature because they are so interesting.

With the 16th century new influences become

powerful. The revival of classic learning stimulated English scholars under the leadership of Grocyn, Linacre, Colet, Cheke. The ideas of the Reformation stirred up clouds of controversy in which appear the great figures of Tynedale, Latimer, Coverdale. The spirit of fierce and gloomy satire which infected the whole world is seen in Skelton and Barclay, the former in a number of pieces, the latter in a translation of Brant's 'Ship of Fools' (1508). The spirit of nationality was aroused and More 'Utopia' (1515) and Elyot 'Gouverneur,' (1531) thought deeply on questions of politics. These men wrote not so much for literary reasons as for some particular purpose; later came the impulse of the Renaissance which brought forth in England a wonderful burst of literature, generally included in the age of Elizabeth. Most important was its manifestation in the drama. To the mystery plays had succeeded miracle plays, and then moral interludes and imitations and translations from Seneca and Terence. By the latter half of the century appeared the first specimens of modern drama, 'Ralph Roister Doister,' by Nicholas Udall (1550) and 'Gorbuduc,' later called 'Ferrex and Porrex,' by Sackville and Norton (1569). The theatre was built in 1579, the Curtain not long afterward, and in the last decade of the century the Rose, the Globe, the Fortune and others. The theatre of the day demanded a drama rich in poetry, rhetoric, declamation and action. The first group of dramatists, Lyly, Peele, Kyd, Greene and greatest of them, Marlowe, were all of necessity experimentalists. They created the romantic drama, with tragedy, comedy, history, into which Shakespeare poured his inexhaustible stores of imagination, observation and wisdom. His plays are typical of the Elizabethan drama; there is little in the other dramatists that you cannot find in him. Yet there were others of great power. Ben Jonson is usually accorded second place and Beaumont and Fletcher, Marston, Middleton, Heywood, Chapman, Massinger, Ford and Shirley, besides others, had each special powers. In time a decline occurred and in 1642 the theatres were closed by order of Parliament and a great dramatic tradition came to an end. One later form deserves special mention: the masque was originally a form of private theatrical and always remained distinct from the plays presented at the public theatres. It was produced for some special great occasion and employed all the possibilities of the day in scenery and costume, music and dancing. The words were often written by dramatists of great ability, notably by Ben Jonson. The most famous and beautiful masque was written at the end of the period, the 'Comus' of John Milton. In lyric poetry as well as in dramatic was the age pre-eminent. In the reign of Henry VIII, Wyatt and Surrey had led the way, though under the influence of Italy, and in 1557 appeared Tottel's 'Miscellany,' an anthology which gathered up the verse of preceding years, while some years afterward came another, the 'Paradise of Dainty Delights.' Later collections are the 'Bower of Delights' (1591); 'The Phoenix Nest' (1593); 'The Passionate Pilgrim,' (1599); 'England's Helicon,' (1600). Another characteristic production was the sonnet-sequence, of which Sidney's 'Astrophel and Stella' (1591, but written before), is one of

the best and earliest examples. Here belong the famous sonnets of Shakespeare, as well as Daniel's 'Delia' (1592), Dryton's 'Idea' (1593), Spenser's 'Amoretti' (1595), among a host of others. One great lyric poet is pre-eminent, John Donne, whose poems, written in his earlier years, had immense influence. This form of the lyric is in the imitations fanciful and finespun, but in Donne himself it is alive and wonderful. Last among the lyrics and as important as anything else are the songs. Music had an important place in English life, and where there was so much singing, there had to be good songs. There appeared great numbers, some in the plays and others in song-books, of which many still exist. A good many are translations and more are very slight, but Shakespeare's and Jonson's among the dramatists, and Campion's among the song-writers are worthy a high place in any anthology. In the 17th century, while the drama lost power, the lyric sustained itself remarkably, though in the hands of fewer artists. They are generally followers along well-known lines in the paths of Spenser, of Jonson, of Donne, but they often produced work quite equal to their masters. The early poems of Milton, the exquisite 'Hesperides' (1647) of Herrick, the courtly and amatory poetry of Carew, Suckling, Lovelace, the religious poetry, passionate and almost sensuous in Crashaw, earnest and devoted in Herbert, these show no failure in power or in genius. One great name in Elizabethan poetry is still to be mentioned, that of Spenser. The 'Amoretti' is as beautiful as any of the sonnet cycles, the 'Shepherd's Calendar' (1579) was an immense influence for a long time, but his great title to fame is the 'Faerie Queene' (1590-96), a work which in literary form stands a little apart from its time. It is a romantic epic, akin to the Italian poetry of the preceding century, but Spenser's own, in its high idealism, its pictorial quality and its mastery of poetic expression. It had imitations and followers, but none of great merit. It is well-nigh impossible to bring the prose of this period under any series of heads. Poetry always comes first in literary development: in the 16th century prose was commonly written for some practical purpose. It is true there was some growth of style; many men labored at improving the vocabulary and elaborating the sentence-structure and the resources in figure and ornament. Yet there were hardly any well-established prose-forms, although the 'Arcadia' (1580-90) of Sidney, the 'Ecclesiastical Polity' (1592-97) of Hooker, the 'Essays' (1597) of Bacon, were each of some influence, especially the last named. Even Lyly's 'Euphues' (1578-79), which was extensively imitated for a decade, produced no permanent form. The pamphlet or the tract is the one characteristic Elizabethan production in prose; its master was Tom Nash, who poured forth numbers of these ephemeral pieces, of wonderful vigor and spirit. Of the same sort of prose the succeeding century showed much. The reign of Elizabeth had been a time for Englishmen to get together and establish their position against the world. Having made themselves a place, they turned to put in order their own house; the 17th century is a period of civil strife and contention. Literature could not avoid the effect of politics; the disturbance of opinion dragged with it into

political or religious controversy many who might otherwise have found expression in literature. Even Milton for a dozen years wrote chiefly prose. We cannot, therefore, look for a varied and definite literary development. The great work of the century was in prose and the greatest and most influential single monument was the King James version of the Bible (1611). The spirit of the Bible is everywhere to be felt in the great prose of the time, transmuted into varying substance in the eloquence of Jeremy Taylor ('Holy Living,' 1650), the quaint richness of Fuller ('The Holy State,' 1642), the stately roll of Sir Thomas Browne ('Religio Medici,' 1643), the powerful vigor of Milton's prose—written during the Civil War, to answer in his own way the call of the country—and the intimate simplicity of Bunyan. A few other writers have little tincture of the struggle of the time, Overbury's 'Characters' (1614), Burton's 'Anatomy of Melancholy' (1621), Cowley's 'Essays' (1656), Walton's 'Compleat Angler' (1653), works of a widely different nature, but showing the quiet, contemplative side of the century that was so distracted by controversy. The Civil War occurred in the very middle of the century and makes a definite bar at least in the poetry of the time. Before it was the Elizabethan age; after it the Restoration. The drama and the lyric before and after are different; even the external form of poetry shows a marked change. At the beginning of the century the verse was free and fluent; at the end it had become concise and brilliant. To the blank verse of Shakespeare succeeded the rhymed couplets of Dryden, organic power giving place to elegant skill. In point of time belonging to both, John Milton in reality belongs to neither. More fully than anybody else he is the representative of Puritanism in literature; its zealous rages, its fanaticisms, its blemishes, its love of liberty and of God give life to his prose tracts on church government, on divorce, on freedom of speech, on the acts of the people: its higher dreams and ideals and aspirations, its unattained possibilities of beauty in 'Paradise Lost' (1667) and his later poems.

With the restoration of Charles II began a new period of literature, often called the classic, most immediately noticeable in the drama. The influence of France in the direction of strictness of classic art and looseness of moral life was strong: added to it was a change in stage conditions, which allowed the development of scenic effect. A realistic, if not spectacular, character, was given to the theatre and the Elizabethan plays, with all their poetry, fell out of fashion, save in versions of the day. A new set of dramatists sprang up to fulfil the conditions. Dryden was a leader, equally strong in tragedy and comedy and what he called the heroic drama, after French models. Otway had the greatest tragic genius ('Venice Preserved,' 1682), but could not so well adapt himself to the taste of the age. Congreve, Wycherley, Farquhar and many others wrote comedies depicting a brilliant social world, but of such gross immorality that Jeremy Collier launched an attack on the whole theatre (1698). His words had some effect and the drama became more decent, but as it really seems to have been quite representative of the life of the time (not arti-

ficial as Charles Lamb loved to think of it), the succeeding drama lacked vitality, and for a hundred years hardly a play was written which is now remembered. Addison's 'Cato' (1713), Rowe's 'Jane Shore' (1714), Gay's 'Beggars' Opera' (1728), Johnson's 'Irene' (1749), Home's 'Douglas' (1756), are noteworthy for various reasons, but not as constituting a powerful drama. It was in other directions that the 18th century was successful and most immediately in the periodical essay. The example of Bacon had given rise to the essay form; one particular kind called the "character" was especially cultivated. The character was like the essay, except that while the essay was usually on some idea, the character was on some person or kind of person. There was a great number of character-books in the 17th century, among the most important ones being those of Overbury and Earle. In this century too come the earliest newspapers. These were generally little more than letters with account of news usually from abroad. The earliest is the 'Coranto' of 1621 of Nathaniel Butters. Besides Corantos there were 'Mercuries,' 'Posts,' 'Gazettes,' 'Journals,' 'News.' By the end of the century the newspaper was a common form. In 1709 Richard Steele published a small paper every other day which he called the *Tatler*. This was not precisely a newspaper, but consisted of a series of essays on all sorts of subjects, sometimes by Steele, sometimes by Addison, Swift, or a number of others, who lent occasional help to the enterprise. The *Tatler* was very popular, and was brought to a close only to be continued in the *Spectator*, in which Addison took the chief part. He took up the idea of Steele and found in it a form of expression exactly suited to his special powers. His essays were popular in the best sense; they were read with delight by all sorts of people, but they dealt with subjects of intelligent interest. Addison was a student of human nature, an observer of life and character, a genial philosopher, and all these elements of his nature were exhibited in the little essays which he wrote for the *Spectator*. The success called forth followers. Addison and Steele followed their joint productions with separate publications, which were sometimes political as well as literary. Among the many 18th century periodicals should be mentioned the *World* (1752), by Lord Chesterfield and others; the *Rambler* (1750) and the *Idler* (1758), by Samuel Johnson; the *Bee* (1758), by Goldsmith. The influence of this sort of literature abroad was also very great; it continued even to the beginning of the 19th century, when a number of clever young men of New York, Washington Irving among them, joined in the production of *Salmagundi* (1807). One distinguishing element in these periodical essays was that of personal character. Some imaginary person was the means by which they were put before the public. The *Tatler* was edited by Isaac Bickerstaff, the *Spectator* by a club of the *Spectator* and others, including the famous Sir Roger de Coverley. This personal element was characteristic of the century, which was extremely sociable and very much interested in human nature. This interest in character for itself is paralleled by an interest in life in action observable in the stories of Defoe. Defoe

was a man who lived by his pen (one of the first who had not been connected with the theatre or the court), whose great gift, so far as literature was concerned, was his power of representing life. His famous 'Robinson Crusoe' (1719) attained inordinate popularity, not only for its adventurous incident, but for its power of realistic story-telling. A little more and these books would have been novels. Addison's 'Sir Roger de Coverley' papers are sketches of life and character without a story. 'Robinson Crusoe' and the many other stories of Defoe have too much action, without attention to life and character, in spite of their realism. These elements were combined by Richardson and Fielding: 'Pamela' (1741), 'Clarissa Harlowe' (1748), 'Sir Charles Grandison' (1753), by the former, were extensively read and influenced all Europe; 'Joseph Andrews' (1742), 'Tom Jones' (1749), 'Amelia' (1751), by the latter, are quite as excellent and somewhat more modern in form. Smollett followed with 'Roderick Random' (1748), 'Peregrine Pickle' (1751), and some others which are a slight variation upon the first of Fielding's. Goldsmith's 'Vicar of Wakefield' (1766) and Miss Burney's 'Evelina' (1778) give us, the one the life of the country and the other of the town, and we have the English novel of domestic life, a form of literature which for a hundred and fifty years has lost and gained but little in essential character. The essay and the novel were new; such things had been in England before, but never the definite literary understanding necessary to constitute a true literary form. Meanwhile the older forms of literature were not neglected. There had been no such histories in England before Clarendon's 'History of the Great Rebellion' (1702) and Burnet's 'History of My Own Times' (edited by his son, 1723). These men wrote of what they had seen; later writers learned to take a larger view and handle larger material. Robertson ('Charles V,' 1769), Hume ('History of England,' 1754-61) and Gibbon ('Decline and Fall of the Roman Empire,' 1776-88), gave example of the combination of scholarly research and literary skill. Oratory also flourished in the exciting Parliamentary struggles which now took the place of court faction. Chatham, Burke, Fox, and many others created a standard and form of eloquence, which yet serves as a model for many speakers and a foundation for more. A special form of oratory becomes important in literature; sermons were widely read. Barrow, South, Stillington, Tillotson, published their discourses in the last half of the 17th century and had many successors in the first half of the 18th. The interest in religion was a part of the general intellectual curiosity of the century; philosophy also became a part of literature. Locke's 'Essay on the Human Understanding' (1690) was more widely read than any other book of such a kind. Philosophy was discussed by Christian as well as by free-thinkers. Berkeley was the former: his 'Principles of Human Knowledge' (1710) has been of importance in the development of metaphysical ideas. Hume was the latter, so much of a skeptic that his 'Essays' (1746) incited Kant, in Germany, to that profound examination of the human reason that has been the foundation of modern philosophy. The 18th century

was a century of reason and of prose. Prose was first simple, either graceful as in Addison, nervous in Defoe or everything in turn in the wonderful prose of Dean Swift, an unapproached master of satire as particularly in 'Gulliver's Travels' (1726). As the century continued, style became more elaborate, of great dignity and stateliness at its highest points (Gibbon and Burke) and even for ordinary purposes admirably effective as in the best of Johnson. The time was intellectual and loved the things of the intellect; hence its poetry was not such as to satisfy the more emotional periods that came after. It was too obviously didactic or satiric, for one thing. Dryden was the first great master in these directions with the 'Hind and the Panther' (1687), and the 'Religio Laici' (1682). In Pope the classic poetry (as it is called) came to perfection; the 'Essay on Criticism' (1711), and the 'Essay on Man' (1732), the 'Dunciad' (1728) and the 'Rape of the Lock' (1712), have never been equaled in English for their telling brilliancy. The followers of Pope caught something of his manner, but produced nothing great, save Goldsmith, who infused a charm into this as into every other kind of literature. Dr. Johnson wrote two strong poems, but his chief power lay elsewhere. The minor exemplars of the characteristic 18th century poetry are of far less value. Addison as a poet, Garth, Prior in 'Solomon' (1718), Young, the author of 'Night Thoughts' (1742), Blair in 'The Grave' (1743), even Akenside, the author of 'Pleasures of the Imagination' (1744), did not all write the characteristic couplet, but they are all of the classic school and all wrote that intellectual poetry that now seems so strangely unpoetic. In lighter forms of verse there were more successful practitioners, Prior and Gay and Swift, but in didactic and satiric poetry, save in the work of the greatest, the 18th century produced nothing permanent. But during the whole classic century there had existed, in its time had been growing, a feeling for other things than those which the reason could put into brilliant and elegant form. It found expression in various ways, chiefly in love for the mediæval past, before the classic conventions had been, and in a feeling for the present wherever those conventions did not exist, namely, in nature and in the heart of man. The first feeling came to expression in various ways, often imperfect, as when Thomas Wharton wrote 'Runic Odes' (1748), when Gray wrote poems inspired by the Norse, 'The Fatal Sisters,' 'The Descent of Odin' (1761), when Sir Horace Walpole imitated Gothic architecture in his house at Strawberry Hill. In 1760 Macpherson published what purported to be translations of Ossian, also 'Fingal' (1762); 'Temora' (1763), and whether they were genuine or not, the fact that they were read shows the interest that was felt in the remote past. In 1767 Chatterton found that he could gain a public for his poetry by pretending that it had been written by a monk of the 15th century. In 1765 Percy published the 'Reliques of Ancient Poetry,' a collection of old ballads, a kind of literature full of the spirit of the past, and absolutely different from the classic poetry of the day. There had been plenty of ballads printed before, even collections of old ballads Ramsay's 'Tea-Table Miscellany,' 'Evergreen' (1724); and they had inspired a few, but now

they became an immense influence. In the other direction, love of nature and human sympathy existed. Thomson's 'Seasons' (1726-30) shows his fresh and charming view of nature, though his use of blank verse and the Spenserian stanza was more in keeping with earlier times. Gray produced very little poetry, but his best, the famous 'Elegy' (1751), has none of the brilliancy and intellectuality which marked the century, and it is noteworthy that in stanza 15, where he originally wrote the classic names of Cato, Tully, Cæsar, he afterward put the national names of Hampden, Milton, Cromwell. Burns was too much of a man to be bound or curbed by fashions, unless more congenial than those of the 18th century. He took inspiration from the ballads and songs of his own country and produced poetry which touched the heart at once. Cowper, though by no means like him, nor apparently of the character of a reformer at all, wrote with a sincere directness that seems like that of an earlier or a later time. The turn of the century shows the characteristic works of the Romantic movement: 'Tintern Abbey' (1798) and 'Michael' (1800), by Wordsworth, may represent the poetry inspired by love of nature and sympathy with man. Coleridge's 'Rime of the Ancient Mariner' (1798), and Scott's 'Lay of the Last Minstrel' (1805), preceded by 'Minstrelsy of the Scottish Border' 1802) stand for the delight in ballads and mediævalism. With these fine poems and others only less fine, it is plain that a new form of art had appeared quite different from the classic conventions of the 18th century. The first great excitement of romance was for strange adventure and the glowing life of the Middle Ages. Wordsworth was for the time unread, while the poetry of Scott delighted all. Scott, however, was eclipsed in the popular mind by Byron, who really was personally the very thing that Scott and the public admired. They longed to hear of men of lofty spirit and recklessness and devotion. Byron was such a man; in 'Childe Harold' (1812) he took England out of itself. In the 'Giaour,' 'Bride of Abydos,' 'Corsair,' 'Lara,' 'Parasina' (1813-15), he presented figures full of the romantic spirit. As the century continued, however, that spirit expressed itself in all sorts of different ways. Wordsworth presents the common delight in nature; Shelley, noble ideas for the regeneration of mankind; Keats, the power of beauty. Succeeding poets go in much the same directions. Tennyson is the most representative poet of the century in presenting to us in forms of great poetic beauty all the phases of the thought of the time, religious, scientific, patriotic, literary. Browning gives us a vigorous optimistic conception of life and work, presented in a wonderful series of dramatic figures. Morris, Rossetti, Swinburne (sometimes called Pre-Raphaelites) may be said to follow Keats in their love of beauty, which they seek not only in mediævalism, but throughout all history sacred and profane. Matthew Arnold's poetry has classic qualities of style and great elegiac charm of thought, but he rightly saw that his true field lay elsewhere. By the last decade of the 19th century, however, the great poets of the Victorian age were dead or silent and it had for some time been felt that they had left no successors. At about this time there was a strong feeling for realism in poetry

as in other forms of literature, and by choice of realistic themes and his realistic manner W. H. Henley became noteworthy. Very different was W. B. Yeats who expressed the craving for some world quite different from current realism. Expressing both of these common feelings the poetry of Kipling ('Ballads' and 'Barrack-room Ballads') met with immediate welcome. It was evidently realistic, but it was also clearly romantic. These two lines of poetic interest and feeling may be seen respectively in John Davidson and Stephen Phillips, and are represented at the beginning of the 20th century by John Masefield and Alfred Noyes. The end of the 19th century had many minor poets, but Francis Thompson by virtue of 'The Hound of Heaven,' will probably have a higher position in the mind of posterity. He had much of the 17th century in his makeup and much of the intense imagination that is generally felt to be the most poetical possession of the poet. In the earlier years of the 20th century there was a great increase of poetic feeling which gradually took more or less definite form in the works of many writers, so that by the 2d decade of the century the "new poetry" was a common phrase. Besides Masefield and Noyes (who was hardly in sympathy with the rest) the chief names that have come to general knowledge are those of Rupert Brooke (d. 1915); James Elroy Flecker (d. 1915); James Walter Delamare, William Davies, Lascelles Abercrombie, James Stephens and D. H. Lawrence. The drama has been weak for the whole century, although all the greater poets essayed the form. Only Browning and Tennyson had even temporary success on the stage, while the works of the professional play-writers have without exception failed of a place in literature. By 1890 a new spirit became active. The comedies of Oscar Wilde made a great impression on the popular mind, by their brilliant dialogue, but the work of Arthur Pinero and Henry Arthur Jones was more representative of the moment in that their effort was usually to deal with the idea of modern social life. The leading spirit in the movement, however, was George Bernard Shaw, who though he began to write plays before 1890 and had some successes as early as 1895, did not seriously impress people till the beginning of the 20th century. When, however, he did begin to gain consideration he attracted public attention by his plays which always presented not merely interesting or amusing dramatic situations, but some discussion of general social ideas. Other dramatists of importance have been James M. Barrie and Grenville Barker, as well as the novelists Bennett and Galsworthy. By 1800 the novel had become a definite form of literature. In the early years of the century Miss Austen, Miss Edgeworth, Miss Ferrier produced pictures of life in England, Ireland and Scotland, respectively, the first of surpassing excellence. A great change was effected by Scott in the Waverley novels (1814-31). It has been pointed out that the lasting power of these novels depends on their full and vital knowledge of Scottish life and character. Scott, at the beginning, had some idea of doing for Scottish life what Miss Austen had done for English. But the real immediate effect of the Waverley novels was to give an enormous impulse to the romance of adventure and scenery and cos-



tume, a romance which found its best expression in the historical novel. The Waverley novels are great historical novels, though, of course, some have little history in them, and they gave a conception and an inspiration which was not wasted. In 1825 appeared the first works of importance of G. P. R. James and of Harrison Ainsworth, who for a quarter of a century achieved a very considerable popularity though they added but little to the possibilities of historical fiction. More powerful than either was Bulwer, whose first work appeared in 1827, and who for 40 years produced not only historical novels, but novels of every kind, works of great talent, though the judgment of time refuses them genius. At much the same time two other writers somewhat extended the field of the novel: Marryat, by sea-stories, which remind one of Smollett; Charles Lever, by stories of the army as well as of Irish life. Brilliant historical novels have appeared through the century: Thackeray's 'Henry Esmond' (1852), and 'The Virginians' (1857); Kingsley's 'Westward Ho' (1855), Dickens' 'A Tale of Two Cities' (1859), Charles Reade's 'The Cloister and the Hearth' (1861), George Eliot's 'Romola' (1862), Blackmore's 'Lorna Doone' (1869), Shorthouse's 'John Inglesant' (1880), Pater's 'Marius the Epicurean' (1885), Maurice Hewlett's 'Richard Yea and Nay' (1900), constitute a series of remarkable value. But the great successes of fiction in the middle of the century were made in the long-familiar forms. Charles Dickens had many minor characteristics, and so had Thackeray, but their novels, as well as those of George Eliot, are novels of every-day life. In the main these three are realists, striving chiefly to depict the life that they knew and saw about them. So chiefly were those who came after them, The Brontës, George Meredith, Charles Reade, Anthony Trollope, William Black, Thomas Hardy, George Gissing, these are realists also, though in only the last two cases of the consistent type developed by their contemporaries in France. Some of them sought in every-day surroundings the romance of character, like the Brontës; some could perceive the rich spirit of comedy, like Meredith. But none felt the need more than once or twice of straying from the familiar life of England. Toward the end of the century the craving for romance began again: it had never been entirely quieted, but it did not come to full expression till Stevenson and Kipling. Both sought the romance of life and character and of the soul, but both were masters also of adventure and incident and striking circumstance and interesting background. Anthony Hope, Stanley Weyman, Conan Doyle, Maurice Hewlett, have in general followed, and in some cases surpassed them. In the last decade of the century appeared several novelists who have since come to be the leading figures of current fiction. Arnold Bennett and H. G. Wells both began with work of an imaginative and even fantastic character, but in different ways turned to something more realistic. Arnold Bennett's 'The Old Wives' Tale' and the books conceived and linked as a series, 'Clayhanger,' 'Hilda Lessways' and 'These Twain,' are careful and thorough presentations of character and manners, differing chiefly from the older conceptions of the novel in their recognition of the ideas dominating modern life.

Wells about 1906 began a series of studies of life of which 'The New Machiavelli' and 'Mr. Britling Sees it Through' have been the most widely read, in which the ideas of the present are embodied in the career of the individual. Besides these are Joseph Conrad, who gives a strong realistic turn to his stories of the sea and of exotic romance, and John Galsworthy, whose chief novels are ironic presentations of the conservative character of life in England. There are also many others who follow not dissimilar courses, of whom the best known are Hugh Walpole, Compton Mackenzie, Ethel Sidgwick, J. D. Beresford, Gilbert Cannan, May Sinclair and Oliver Onions. A third development of the century has been in the path of criticism, which at first found expression chiefly in the periodical. The magazine has been one of the most characteristic elements of 19th century literature. There were magazines in the 18th century—the *Monthly Review*, the *Critical Review*, the *Gentleman's Magazine*—but the chief periodical was the Addisonian essay. The *Edinburgh Review* (1802) and the *Quarterly Review* (1809) were the beginning of a new movement. *Blackwood's Magazine* (1817), the *London Magazine* (1820) and *Fraser's Magazine* (1830), together with many weeklies and dailies, were the beginning of a flood of literature that is now the form most familiar to us. The influence was at first chiefly critical. Jeffrey, the first editor of the *Edinburgh*, with Gifford of the *Quarterly*, set the style of a criticism, which though often unfairly slashing and ridiculously high and mighty in tone, had merit often in expressing sincere and definite opinions in literature and politics. A sort of gaiety and even charm was given by Wilson, who wrote under the name of Christopher North, by Sidney Smith and Lockhart. But the most important development came in the field of the personal essay. The 'Essays of Elia' (1820) by Charles Lamb, go beyond the Addisonian essay in their unfettered expression of a charming personality. 'The English Opium Eater' (1821), of Thomas De Quincey, is still farther away from the 18th century in form and spirit, and so is the 'Table Talk' (1824) of Hazlitt. All these are sincere personal utterance, and in their sincerity and personality lies their strength. In the main we may call the work of these men critical, for they were all absorbed in letters, and their view of life was essentially a criticism of literature. Something more in the way of established form were the famous 'Essays' (beginning 1825) of Macaulay, the most remarkable works of their time in the power of focusing wide reading and immense knowledge into forms of extreme brilliancy. A striking contrast is offered by Carlyle, who began by essays of the accustomed character, though not ordinary in style, but after some years produced 'Sartor Resartus' (1833), expressive of his own vigorous personality and thinking, more extraordinary in form than any of his later work, but not more original or powerful. Carlyle had by no means the immediate fame of Macaulay, but his influence on the thought of his time has been vastly greater. Both were historians as well as critics, and by their interest in life and sympathy with man they brought in a new and fascinatingly interesting kind of historical writing, which the later influence of Darwinism and of science in gen-

eral, has done much to deaden. Hallam before them should also be mentioned and Green after them. John Ruskin began his career as critic with what seemed the impossible task of de-throning false masters of painting, and establishing an ethical foundation for art. About 1850, having succeeded in his earlier task, he began a struggle against a much wider range of evil, which was not so fortunate. Matthew Arnold also understood the range of the critic as extending beyond the field of art: his views on politics and religion were an influence in the history of thought, but naturally will not last as long as his conceptions on literature. Walter Pater took even a wider view of art, being at home with painting, architecture, sculpture, as well as with literature. He represents the so-called "aesthetic" position which developed from Preraphaelitism. The most noteworthy essayist of the opening century is Gilbert K. Chesterton, whose ready paradoxes cover much sound thought. In philosophy and science the century has been pre-eminent, and many great books have been produced. The last field hardly belongs to literature, although Darwin, Huxley and Tyndall were masters of style and could make the results of scientific work absorbingly interesting. More might be said of philosophy and theology, though here little has been produced that will last as literature, except perhaps John Stuart Mill's 'Logic' (1843), Cardinal Newman's 'Apologia pro Vita Sua' (1864), and parts of Spencer's 'Synthetic Philosophy' (1860-1900), all of which stand as representative of important movements in the history of thought.

There are many histories of English literature. The most elaborate and authoritative is the 'Cambridge History of English Literature,' the work of a great number of representative students. That of Garnett and Gosse is an interesting general account, richly illustrated by extracts and reproductions of manuscripts and prints. The three volumes on different periods by Saintsbury and Gosse cover the last four centuries in a convenient form. The work of Taine (translated by Van Laun) expresses his views of the development of literature from national life. That of Ten Brink (translated by Keneday) is unfinished, but covers the ground where German scholarship is strongest, namely, Anglo-Saxon and Middle English. Brandl in Paul's 'Grundriss der germ. Philologie,' gives a very full and convenient summary. Morley's 'English Writers' is a very full account in 10 volumes, but has not got beyond Shakespeare. The 'English Men of Letters' series provides lives of the greatest authors. Ward's 'English Poets,' and Craik's 'English Prose,' are valuable, giving a summary of facts, a criticism by a writer of note, and a number of extracts in case of all distinguished poets and prose writers.

EDWARD E. HALE,

*Professor of English, Union College, Schenectady, N. Y.*

**ENGLISH LITERATURE, Middle Period.** The term Middle English may conveniently be taken to include the period 1100-1500. For more than a century after the Conquest, however, the majority of works produced and read in England were written either in French or Latin. Literature in the vernacular, which had sunk to a low level by the beginning of the 11th century, did not revive materially

until the reign of John. The 'Anglo-Saxon Chronicle' continued to the year 1154, and a few religious works, chiefly of linguistic interest, almost exhaust production in English during this era of transition. During the 13th century English began to compete with the other tongues for supremacy, and by the time of Chaucer its victory was assured, although French and Latin continued to be widely used. At first, the progress of the vernacular was greatly hindered by dialectical differences in various parts of the country. The West-Saxon and Kentish, the Mercian, and the Northumbrian of the earlier period had developed respectively into the Southern, Midland and Northern, with some changes of boundary. Of these, East Midland was most important, as the dialect of London and Chaucer, and the parent of Modern English. The language as a whole shows very marked differences from Anglo-Saxon, not only in the addition of many foreign words, chiefly French and Scandinavian, but in changes in the vowels and diphthongs, in the disappearance of inflectional endings, and in a freer use of particles and connectives. The dialectal peculiarities gradually became less marked, until at the end of the period there was practically only one literary dialect, with the exception of Scottish.

The influence of Anglo-French and Anglo-Latin upon Middle English was exceedingly important. The Normans took great interest in historical writing after their settlement in England, as the Latin chronicles of such men as Ordericus Vitalis, Henry of Huntingdon and William of Newburgh attest. About 1136 Geoffrey of Monmouth produced his fictitious 'Historia Regum Britanniae,' a book condemned by serious historians, but of great significance for mediæval romance. It was later reworked in French rhymed versions by Gaimar and Wace. The Normans were fond of romantic stories, and even retold in their own tongue the deeds of various native English heroes. More serious historical work was done in French verse by such men as Garnier de Pont Saint Maxence or Jordan Fantosme. Churchmen like Lanfranc and John of Salisbury wrote on theological matters, and there was early much activity in the new English universities. Latin writing of a lighter sort is represented by the 'De Nugis Curialium' of Walter Map, or the 'Speculum Stultorum' of Nigellus Wireker. The Normans were a people of practical mind, and most of their literature consisted of utilitarian or devotional prose. Scientific facts, or supposed facts, interested them greatly. They were clever tellers of tales, both of the fabliau type and those pointing a moral. Especially noteworthy is the work (c. 1175-85) of the poetess Marie de France, who wrote a charming collection of 'Lais,' and a book of fables, the 'Ysopet.'

Earlier Middle English literature is better studied by types than by authors. Originality, as a general thing, counted for little in mediæval days, and works in the vernacular during the 13th century were based almost without exception upon French and Latin models. The narrative literature is of far greater interest than the religious and didactic writing. The French metrical romances, artistic poems dealing with love and war, and chiefly intended for the higher classes, were made accessible to the

English after the middle of the 13th century. The cycle of King Arthur and his knights was the most important and popular. A smaller and less favored division dealt with "the matter of France,"—the deeds of Charlemagne and his warriors. A third group is based on native English and Germanic themes—King Horn, Havelock, Bevis of Hampton, Guy of Warwick, etc. Stories of Troy and Thebes form a fourth class. The Troy-story deserves attention because of versions of the Troilus-Cressida theme by Chaucer, Henryson, Lydgate and Shakespeare. Romances of eastern origin, with a few others not readily classifiable, complete the list. By the time of Chaucer, the metrical romances were showing signs of degeneration, and in the 15th century prose romances took their place. In strong contrast to these are the fabliaux, short, witty, rhymed tales, intended for the lower classes, usually of a satiric character, and frankly indecorous. They were never as popular in England as in France, although stories of this type form the largest genre-division of the 'Canterbury Tales.' Pious tales, generally representing supernatural occurrences in every-day life, and beast stories, like the 'Fox and the Wolf' (13th century), were popular. Noteworthy, too, are the collections of stories, often, as in the case of the 'Gesta Romanorum,' used by preachers as *exempla* upon which to base homilies. Many romantic narratives reappeared in altered form in the ballads. These "stories in song" differed widely from the romances, being short, stanzaic, allusive pieces of unknown authorship, perpetuated among the people by oral tradition, and dealing with a great variety of material. The popular lyric—quite a different thing—is represented by such pieces as 'Sumer is yumen in,' or 'Blow, Northern Wind.' In the secular lyric the French influence was again predominant. Secular love-poetry was often applied to religious ends, as in the 'Love-Rune' of the Franciscan monk, Thomas de Hales. In the 14th century French lyrics were extensively imitated, as the work of Chaucer and Gower shows. As for metrical chronicles, three deserve especial mention. Most important is the 'Brut' of Layamon (c. 1205), so called because it traces British history from Brutus. Although dependent upon earlier French and Latin work, it shows imaginative power and patriotic feeling. The same love of England appears in the chronicle of Robert of Gloucester (late 13th century), which may have been written by more than one man, and in the historical work of Robert Mannyng of Brunne in the 14th century.

The devotional and didactic literature is somewhat difficult to classify, since the various types were not always clearly differentiated, and borrowed much from secular writing. A favorite form of conveying wisdom was the proverb poetry. An early collection of this sort was attributed to King Alfred, and another was put into the mouth of a personage called "Hending." A similar purpose was served by the "debates," the most noteworthy of which is the 'Debate of the Body and Soul' (12th century), in which each speaker accuses the other of being responsible for the death of the dead man. The 'Owl and Nightingale' (c. 1220) is the most important secular debate in English. There was much work on scientific subjects, and this was often made to point a moral, as in the 'Bestiary' of the early 13th century, which appends a

"significatio" to each description. A vast number of homilies and devotional treatises were written. The 'Poema Morale,' "a penitential sermon in verse," dates from 1170. The 'Ancren Riwe,' or Rule for Nuns, is an early prose monument of some importance. More celebrated is the 'Ormulum' (c. 1200), a set of pedestrian metrical homilies valuable to the philologist on account of a peculiar system of spelling. In the 14th century Dan Michel of Kent, the author of the 'Ayenbite of Inwit,' William of Shoreham, who wrote stiff didactic poems, Robert Mannyng of Brunne, who versified a French manual and gave it the title 'Handlyng Sinne,' and Richard Rolle of Hampole, are all noteworthy. Richard Rolle, the mystic, hermit and preacher, was more important as a personality than an author, yet his works were much esteemed in their day. Chief among Bible paraphrases are an early version of Genesis and Exodus (c. 1250), in the Midland dialect, and the 'Cursor Mundi,' written in the north. Legends and lives of the saints were much in demand, and huge legend collections were made for homiletic work. The Tales of the Prioress and Second Nun in Chaucer illustrate this genre.

The most important figure in Middle English literature is Geoffrey Chaucer (1340-1400). A Londoner by birth, he was brought up in the atmosphere of the court, took part in the French wars, was often employed upon diplomatic missions, and held various public offices. His work may be somewhat arbitrarily divided as follows: The first period, to about 1372-73, when he first visited Italy, reflects the influence of French poetry. Besides a number of shorter lyrical pieces, most of which are not extant, the period includes a translation of a part of the 'Romance of the Rose,' and 'The Book of the Duchess,' a lament for the death of the wife of his patron John of Gaunt. The second period, which closes about 1385, reveals him imitating Italian models, particularly the work of Boccaccio. Here belong 'Troilus and Cressida,' 'Anelida and Arcite,' 'The House of Fame,' 'The Parliament of Birds' and some stories later utilized in the 'Canterbury Tales.' This period shows a great advance in versatility and poetic power. The so-called English period, in which he attained the summit of his powers, has been held to include the 'Legend of Good Women,' but recent research puts much of it earlier and makes plain the strong influence of French. The chief work of this period, and his masterpiece, is the 'Canterbury Tales.' The stories were borrowed from various sources; the plan of the whole resembles that of the 'Decameron,' but there is no evidence that Chaucer was acquainted with it. Besides two prose Tales, Chaucer translated Boethius and wrote a treatise on the astrolabe. The chronology of his writings has not yet been determined with complete accuracy.

Four important alliterative poems of the latter half of the 14th century, written in the West Midland dialect, may be referred to one author, whose name has not been preserved: 'Sir Gawa'n and the Green Knight,' 'The Pearl,' 'Purity' and 'Patience.' The first of these is generally considered the finest of the metrical romances, because of its elevation of tone, descriptive power and narrative skill. It is written in a highly artificial style of verse. 'The Pearl' describes the appearance of a beau-

tiful maiden in Heaven, seen in a dream. It is probably to be interpreted allegorically, although the poem has often been held to reflect the grief of a real bereavement. The other two poems, which are of minor value, exalt the virtues indicated in their titles. Alliterative verse, without end-rhyme, was employed by William Langland, whose bitter satire contrasts with the genial irony of Chaucer. 'The Vision of Piers the Plowman' attacks the evils of the day by means of various allegorical figures seen in dreams. A continuation of the same material appears in the pieces called 'Do Wel,' 'Do Bet' and 'Do Best.' The allegory is sometimes realistic and sometimes mystic. The 'Vision' appeared in three different versions in the latter part of the 14th century. It has been doubted that this is all the work of one man and too much weight has been attached to supposed autobiographical evidence in it. 'Richard the Redeless' is generally assigned to Langland.

The fame of John Gower (d. 1408) rests, apart from a series of French *ballades*, and minor pieces, upon three works, the 'Speculum Meditantis,' a moral allegory in French verse, the 'Vox Clamantis' in Latin, dealing with the social unrest of his day, and the 'Confessio Amantis' in English, his best-known poem. The 'Confessio' consists of a series of tales, strung on a thread of story. The priest of Venus is sent to "confess" the lover, and gives him instruction by means of tales illustrating the vices and virtues, with special applications to matters of love. Many of these tales are well and simply told, but the artificial and highly finished octosyllabic couplet soon becomes monotonous. The poem is too long (nearly 34,000 lines), and is far inferior to the work of Chaucer. An enormously prolific poet, too, was John Lydgate. His long poems, like 'The Troy-Book,' or 'The Falls of Princes,' are tedious versifying; his minor poems and 'Fables' show him at his best. As a disciple of Chaucer he stands with Thomas Occleve or Hoccleve, a more interesting personality, but less productive and accomplished than Lydgate. Occleve's chief work is 'The Gouvernail of Princes.'

The prose work of John Wiclif was primarily utilitarian. He was greater as a personality than as a writer, but his translation of the Bible (c. 1380) did much to fix the form of the language, and his simple and direct sermons appealed strongly to the lower classes. He was assisted in translating the Old Testament by Nicholas of Hereford, and the whole was later revised by John Purvey. An undue importance has sometimes been attached to the fictitious 'Travels' supposed to have been made by a Sir John Mandeville in the 14th century. The book was originally written in French, but the facts of its authorship are not yet fully known. Though purporting to be authentic, it is full of grotesque descriptions of the East, mostly borrowed from mediæval travel-books. See MANDEVILLE.

The 15th century was a singularly barren era. England was almost devoid of poetry of distinction; the example of Chaucer inspired little in the south, and the Wars of the Roses had a most unfavorable effect upon literary production in general. Some advance was made in prose writing, however, through the interest taken in historical, legal, controversial and religious subjects. Reginald Pecock, the great

opponent of the doctrines which had been advocated by Wiclif, is remembered for his 'Repressor of Over-much Blaming of the Clergy.' Sir John Fortescue, the author of 'The Governace of England,' and the chroniclers Capgrave and Fabyan also deserve mention. Perhaps the most distinguished work of the century was Sir Thomas Malory's 'Morte d'Arthur.' This collection of romantic tales dealing with King Arthur and his knights, told in melodious prose with great skill and charm, was finished about 1470, and printed 15 years later by Caxton. Malory drew most from French romances. Although he invented little, he was no mere compiler, but a great literary artist. The introduction of printing and the publications of Caxton mark a new era in English letters. Much of the material which Caxton printed he translated from other languages himself. His activity exerted a strong influence in the development of English prose.

A compensation for the dearth in English proper in the 15th century appears in the emergence of Scottish literature. The first noteworthy work in this dialect, with the exception of certain legends and romances, is the 'Bruce' of John Barbour, whose life falls within almost the same dates as that of Chaucer. The poem partakes of the nature both of a rhymed chronicle and a romance, and though lacking in finish, is full of vigor and animated by patriotic spirit. It celebrates the deeds of Robert Bruce, with occasional lapses from historical accuracy. Andrew of Wyntoun's 'Original Chronicle'—so called because he began from the very beginning—is an exceedingly monotonous piece of versifying. The exploits of William Wallace were celebrated by Henry the Minstrel, or Blind Harry, as he is often called, in a poem which takes great liberties with history. Of Blind Harry little is known. A pronounced imitator of Chaucer, and not an unworthy one, was King James I of Scotland, who celebrated his love for Lady Jane Beaufort in 'The King's Quair' (1423). In structure, language and general literary treatment it is highly artificial, but full of grace and poetic feeling. It derives additional interest from the romantic career and early death of its author. In variety and excellence of work, Robert Henryson, who flourished in the latter part of the 15th century, holds an important place. He wrote the earliest extant English pastoral, 'Robene and Makyne,' and a notable collection of 'Fables.' The influence of Chaucer is seen in 'The Testament of Cressida,' which describes Cressida's unhappy death with great dramatic power. In minor poems he was often felicitous. An elaborate though tedious and awkward bird-fable is the 'Howlat' or 'Owlet' of Holland. The greatest poet of the period was William Dunbar (1460?-1520?), who led a wandering life in his youth, was later attached to the court of James IV of Scotland, and entered holy orders. Most of his poems are short and a large number of them are satirical. More ambitious are 'The Thistle and the Rose,' which commemorates the marriage of the king, and 'The Golden Targe,' an elaborate allegory. 'The Dance of the Seven Deadly Sins,' 'The Flyting with Kennedy,' a brother-poet, 'The Two Married Women and the Widow,' and 'Tidings from the Session' are all representative pieces. 'The Two Friars of Berwick,' a piece of vigorous Chaucerian narrative, is as-

cribed to him. 'The Lament for the Makers' strikes the elegiac note, but Dunbar was, on the whole, lacking in pathos and tenderness. He was a poet of great variety and originality, using both the "aureate style" then in vogue, and the rude dialect of the people with equal skill. Gawin Douglas, Bishop of Dunkeld (1475-1522), wrote rather stiff allegorical poems, 'The Palace of Honor' and 'King Heart.' His most important work is his translation of Virgil. Douglas was the most learned of the Scottish poets, and his work was designed to appeal chiefly to the upper classes. Much of the work of Dunbar and Douglas falls outside the formal boundary of this literary period, 1500, yet in the general character of their poetry and especially in their imitation of mediæval models they are properly to be considered with the earlier men. The same is hardly true of the work of Sir David Lyndsay of the Mount (1490-1545), who completes this group of Scottish poets. The reformatory tone and national appeal in his writings place them in the era following.

In English literature proper a similar distinction is to be made. Alexander Barclay's translation of the 'Narrenschiff' of Sebastian Brandt, which he called 'The Ship of Fowles,' and 'The Pastime of Pleasure' of Stephen Hawes, a "belated Chaucerian," both produced in the first decade of the 16th century, belong far more to the age that had passed than does the poetry of Skelton. Although some of Skelton's early work suggests imitation of the older poetry, his most characteristic pieces do not fall within the bounds of Middle English. Neither Hawes nor Barclay were even secondary poets; their prominence is chiefly due to the fact that they lived in a time when little good poetry was written.

The miracle plays flourished in England from the early part of this period until the end of the 16th century. The morality play, a less important genre, arose in the second quarter of the 15th century, and, with the interlude, for a time rivaled the popularity of the miracles. For a discussion of the rise of the drama in the Middle English Period, see MIRACLE PLAYS.

Bibliography.—There is a comprehensive and detailed discussion of the earlier Middle English period by Schofield, W. H., 'English Literature from the Norman Conquest to Chaucer,' which contains bibliography and chronological tables; for individual authors consult the 'Dictionary of National Biography'; for bibliography and brief discussions, Wells, J. E., 'Manual of the Writings in Middle English'; for literary history in general, the 'Cambridge History of English Literature' (Vols. I and II, Cambridge 1913), 'Grundriss der germ. Philologie'; Jusserand, 'Literary History of the English People' (2 vols.); Morley, H., 'English Writers' (Vol. III-VII); Saintsbury, 'A Short History of English Literature'; Chambers, E. K., 'The Mediæval Stage.' For the French literature of the period, cf. Paris, G., 'La litt. franç. au moyen âge,'—'Mediæval French Literature,' in Temple Primer Series. For the Scottish poets, Henderson, T. F., 'Scottish Vernacular Literature, A History'; and chapters by Gregory Smith in the 'Cambridge History of English Literature' (Vol. II, Cambridge 1913).

WILLIAM WITHERLE LAWRENCE,  
Professor of English, Columbia University.

## ENGLISH LITERATURE, Elizabethan Period.

### THE DRAMA.

At the beginning of the reign of Elizabeth the conflict between mediævalism and humanism was rife in the drama as in other forms of literature. For the preceding half century there had been a confusion of types; miracle, morality, interlude, and farce existing side by side and exhibiting various differentiations and there had been a confusion of theatrical conditions, play-acting still remaining largely in amateur hands. Neo-latin imitations of the classics were being succeeded by academic attempts in the vernacular. 'Ralph Roister Doister,' written by Nicholas Udall for the school performance, had already in 1552 marked the appearance of comedy as a distinct form after the Plautian model, and 'Gorboduc,' by Sackville and Norton, performed in 1562 before the Queen, was the first vernacular tragedy. Two other extant plays written within the next few years and performed by amateurs, 'Jocasta' and 'Tancred and Gismunda,' were, like 'Gorboduc,' attempts by Englishmen of culture to imitate the tragedies of Seneca in accord with the practice of Italian humanists. Meantime 'Apus and Virginia' and 'Damon and Pithias,' mixtures of tragedy and comedy, exhibited the persistence of popular methods combined with classical borrowings, while 'Cambyses' and 'Horestes' were formless chronicles of atrocities without any perceptible classical decorum. The building of the first London theatre in 1576 was the sign of a speedy triumph of the professional companies as the chief purveyors of the drama. A dozen years later the advent of a group of gifted poets prepared the way for Shakespeare by determining the course of a popular drama that was to be literary though disregardful of classical restrictions.

Comedy, where the departure from mediæval forms required by the humanists was far less than in tragedy, was the first to attract literary talent to the public stage. The plays of Wilson revealed a satirical comedy of manners emerging from the morality, and the entertainments devised by Lyly for the children companies, combined lyrical and spectacular attractions with a refined wit and a certain graceful courtliness. Later Green introduced sentimental comedy with its averted tragedy and its idealization of women. Such hasty summarizing, however, does scant justice to the variety and ingenuity of the experiments that preceded Shakespeare, drawing their material from every field from classical myth to native folk lore, and essaying and amalgamating every department of comedy from the Plautian to the pastoral. Most characteristic, perhaps, of all was romantic comedy, usually based on Italian *novelle* and offering a medley of fun, sentiment and adventure.

In tragedy Kyd adapted Seneca to the conditions of the popular theatres, discarding most of his structural scheme but retaining the story of revenge, the accompanying ghost, the horrors and the moralizing; and thus in the 'Spanish Tragedy' (c. 1587), creating a special type destined to a vigorous existence. Marlowe (1564-93) turned his back on Senecan methods and brought to the rambling and discordant structure of the current popular history plays his splendid blank verse and his soaring imagination. 'Tamburlaine,' 'Faustus,' the 'Jew of

Malta,' and 'Edward II,' the chief plays of his half dozen years of dramatic activity, delighted the vulgar by their violence and spectacle, and at the same time made the public stage the abode of noble poetry and genuine passion. His genius, though never fully developed, remade tragedy and history, giving to the chronicle structure the unity of a protagonist, possessed by extraordinary ambition and engaged in tragic conflict with overpowering opposition.

In Marlowe, as in the other early Elizabethans, there is much that is fantastic, crude and absurd. The primary aim of each dramatist was to present a story so as to delight a motley audience; hence the tendency was naturally toward stories of sensational crimes for tragedy and of romantic adventures for comedy, without much care for the isolation of either species. Like Marlowe, however, the other dramatists were poets as well as playwrights, stimulated by that imaginative idealism so nobly characteristic of the national temper in the years of Elizabeth's greatness, and in their exuberant and somewhat over-fantastic verse reflecting the audacity, adventurousness, emotional extravagance and undaunted aspiration of the age.

Shakespeare's apprenticeship was served in this period, and his early plays naturally follow the forms then current and exhibit the qualities most prominent in other dramatists. The 'Comedy of Errors' is an adaptation of Plautus; 'Love's Labour's Lost' follows Lyly; the 'Two Gentlemen of Verona' recalls the sentimental comedy of Greene; 'Titus Andronicus' is a melodrama of atrocities after the fashion of Kyd; 'Henry VI' is dominated by Marlowe, and 'Richard III,' following the Marlowean formula, surpasses the master in the vigorous delineation of the villain protagonist and in the stage effectiveness of his part. But Shakespeare soon left his fellows far behind. The 'Midsummer Night's Dream' and the 'Merchant of Venice' transcended the romantic comedies that had made them possible on the London stage, and 'Romeo and Juliet' as completely surpassed the prevailing tragedy of blood. By 1600 Shakespeare had created his great series of comedies and in the Falstaff plays had wrought a union of comedy and history such as the early chronicle plays had only dimly foreshadowed.

By 1600 new forces were manifest in the drama. A young poet, Marston, was following his successful satires by a series of plays, in part tragedies of blood on the Kydian model, and in part satirical tragi-comedies, which aimed to be searching studies of evil. In 1599 Ben Jonson's 'Every Man in His Humour,' acted by Shakespeare's company, was prefaced with a declaration of war on the absurdities of chronicle history and romantic plays, and with the promise of the creation of a comedy dealing with contemporary manners. Jonson, indeed, continued a powerful force in the drama for the next 25 years. His preaching was all directed toward the establishment of a more conscious and painstaking art, and its regularization by classical examples, while his practice resulted in a noteworthy series of satirical comedies, presenting with powerful humor and realism the follies and vices of the day. Chapman and Middleton were also writing comedies of domestic manners, and the whole trend of the

drama from 1600 to 1608 was away from romance and sentiment, resulting in a satirical and realistic treatment in comedy and a more searching analysis of evil in tragedy. Under these circumstances Shakespeare's great series of tragedies was produced. This is not the place to speak of their lasting significance, but merely to note that his genius, now in the full maturity of its powers, was still engaged in transforming the prevailing types of drama. Narratives from chronicle and *novella*, so often the sources of formlessness of structure, resulted in the splendid dramatic concentration of 'Macbeth' and 'Othello'; the absurd tragedy of blood, popular again through the efforts of Marston and others, became 'Hamlet' with its infinite suggestiveness of human tragedy; the grotesqueness characteristic of mediæval as well as Elizabethan drama had its final justification in 'Lear.'

By 1607-08 the success of the heroic plays of Beaumont and Fletcher had brought the romantic and idyllic again into favor and perhaps given the suggestion for Shakespeare's return to romantic tragi-comedy in 'Cymbeline,' a 'Winter's Tale,' and the 'Tempest.' Heroic romances, such as 'Philaster' and the 'Maid's Tragedy' succeeded not only because of their poetry and their sensational contrast of sentimental love and sensual passion, but even more because of the telling theatrical effectiveness of their situations and the clever alternations of suspense and surprise with which their ingenious plots were complicated. The comedy of Beaumont and Fletcher, especially in its later development by Fletcher, like their heroic plays, had a long continued influence on the drama. Possessing ready wit, great poetic facility and an abundant invention, but without moral taste or any serious criticism of life, Fletcher marks a stage in the drama that may fairly be called decadent when we recall the sound moral sense and the artistic aspiration of the early plays. Yet the last decade of Shakespeare's life was the time of Jonson's greatest comedies, of the masterpieces of Beaumont and Fletcher, and of some of the best work of Chapman, Tourneur, Webster and Middleton.

The very existence of these masterpieces was of itself a factor in the drama's decline. Webster, writing in 1612, made the first avowal of obligations to his great contemporaries; and henceforth the increasing recognition of the greatness of the immediate past seemed to stifle rather than to inspire innovation and experiment. Webster himself, borrowing freely from others, carried the tragedy of blood to its final development in the powerful and gloomy 'White Devil' and 'Duchess of Malfi.' Middleton in collaboration with Rowley created scenes of powerful tragic interest in 'A Fair Quarrel' and the 'Changeling.' Massinger, collaborating often with Fletcher and to a considerable extent borrowing Fletcher's methods, produced a body of tragedy and tragi-comedy, morally didactic, and rhetorically excellent, but in characterization and poetry somewhat deficient. These are only a few of the writers of tragedy during the reign of James I; in the development of comedy, where less poetical excellence is demanded, the number of important contributors was much larger. Middleton's most characteristic work was a group of lively comedies that exposed contemporary manners with the frank-

est realism. Massinger, though on the whole deficient in humor, produced in 'A New Way to Pay Old Debts' the noteworthy character of Sir Giles Overreach that has attracted many great actors, including Kean. Dekker and Heywood, writers without great literary pretensions, wrote a large number of successful plays. Dekker ranged from the romantic idealism of 'Old Fortunatus' and the sentiment and merriment of the 'Shoemaker's Holiday' to the painful realism of the 'Honest Whore.' Heywood, always a skilful and inventive playwright, likewise wrote plays of every kind, achieving a real masterpiece in his 'A Woman Killed with Kindness.' This play may be classed as a sentimental tragic-comedy or as a domestic tragedy, a class which includes a number of plays depicting current crimes and goes back at least as far as 'Arden of Feversham' in Marlowe's day. One other dramatic form, extremely popular in the court of James I, must be mentioned, the court mask. For these scenic and musical entertainments many dramatists, and notably Jonson, wrote libretti; and the spectacles and dances in turn had an important influence on the popular theatres. The dramatic product of the reign of James I (1603-25) was indeed fully as large as that of the reign of Elizabeth, and, including as it did the last nine years of Shakespeare's career, vastly greater in value. But the enthusiasm and earnestness of the days of the Armada were succeeded by a time of immorality, corruption, and national weakness. The people were turning more and more to Puritanism, but the drama, following the court, grew less serious, more licentious and gradually forgetful of its high calling.

During the reign of Charles I the drama offered little that remains notable, outside of the continued work of the older writers and the plays of Ford and Shirley. Ford, a poet of original and lofty genius, ranks with the great dramatists in the intensity of his tragic crises, but he sought themes and motives, abnormal and decadent. The great dramatists of the preceding generation stimulated Shirley, who was their last worthy follower and who often recalls but never quite equals their best work. Of comic dramatists Brome, of "the tribe of Ben," and Davenant, who belongs to the Restoration, are possibly the most noteworthy. But the great majority of the many plays produced were mediocre. The drama no longer represented the nation; nor in the approach of the civil conflict could it longer command the interest and energy of great intellects or imaginations. It had little virility left when the Puritans closed the theatres in 1642.

Within a few years Chapman, Dekker and Jonson, the last surviving dramatists of Elizabeth's time, had died. Their lives had spanned the entire course of the drama's development, its rapid rise and its splendid culmination as well as its decline. The 30 years from Marlowe's first play to the death of Shakespeare include, in fact, all that is great in this amazingly rapid development. Incomparable as this period is because it contains the career of Shakespeare, it is hardly less astonishing because of the variety and range of the work of his fellows. Lacking, as even Shakespeare's plays lack, in the symmetry and unity of the Athenian drama; faulty, as his plays are often faulty, in the over-exuberance of language and

the violence and extravagance of scenes; suffering, as his genius suffered, from the crudity of a bare stage and an immature dramaturgy; these Elizabethan plays, taken as a whole, reveal in however inferior measure, his great excellences, the untrammled play of wit, sentiment, fun and fancy; a splendid energy of diction and of dramatic treatment; a searching revelation of human character, and an abounding grace and power of poetic expression. See DRAMA; ENGLISH LITERATURE; ENGLISH LITERATURE—MIDDLE PERIOD; GREAT BRITAIN—TREND OF THOUGHT AND LITERATURE IN THE 19TH CENTURY, and consult works there referred to.

A. H. THORNDIKE,

*Professor of English, Columbia University.*

#### NON-DRAMATIC POETRY.

Elizabethan poetry is the product of the Renaissance,—the flowering of the English stock under the fertilizing power of European thought. English literature at all points—in Alfred's time, in Elizabeth's, in the 18th and 19th centuries,—has owed its great moments to foreign inspiration, but this is true of no age so conspicuously as of the Elizabethan. The period is short, if it be measured strictly by Elizabeth's reign, 1558-1603; and even if the limits be broadened to include Wyatt and Surrey at the beginning and all of Shakespeare's work at the end, it is still but narrow room for the development of the crude religious play into the drama of Shakespeare and Jonson,—of the clumsy sonnets of Wyatt into the great sequences of Sidney, Spenser and Shakespeare,—of the stiff Tudor music into the noble harmonies of the madrigals and the sweet melodies of the airs.

Perhaps because of this swiftness of development, the age illustrates with unusual clearness the transference of life to books. The rush of genius draws into its vortex most of the experience about it; Spenser's friends enter the 'Faërie Queene' unchanged, and in spite of the allegory, undisguised; Sidney's passion takes over the incidents of his wooing with an immediateness that the occasional bookishness of his inspiration cannot smother; history, scarce made, is subject for a play; the gossip of a shipwreck becomes the 'Tempest'; and—perhaps most interesting of all—those first poets themselves, the type of the age, Surrey, Sidney, Greville, Raleigh, are caught up as they drop from life, and continue immortal in Shakespeare's young men—Biron, Valentine, Romeo. The contrast here suggested between the mass and power of its literary inheritance and the directness of its foundation upon life, is the distinction of Elizabethan poetry, and perhaps the source of most of its problems.

In this swift drawing-in of Continental Renaissance thought with English history and character, the age is set off by three great names—Spenser, Shakespeare and Milton—for though Milton stands well outside the Elizabethan period, he is the last term in its development. The apparent remoteness of Spenser, his un-English quality, is due probably to the fact that he is nearest to the great wave; he takes over a larger quantity of unnaturalized material; he represents the early school of wholesale colonizers of Italian thought on English soil. Yet he takes over into his writings quite as much

of English life, even of English incident, and quite as much of English character, as Shakespeare. The great dramatist, at first glance so natural, so near to his race, so untouched by the tyranny of books, is indeed all these things, yet his imagination starts always in some foreign suggestion. Aside from the different scale of genius, he is as English as Spenser—no more so; but he represents a more complete blend of the foreign themes with the native mind. So Milton also, heir to the assimilated learning of the Renaissance—to humanism, yet draws on the most English sources of life—English experience, English character, English landscape. These three poets illustrate the Elizabethan age in that they are typically individual, typically English, and typically children of the Renaissance mind.

It is usual to take as the beginning of Elizabethan poetry the book in which the Elizabethans themselves saw the herald of their day—'Tottel's Miscellany' (1557). This book, a publisher's venture, contained the work of several courtly poets, notably of Sir Thomas Wyatt (1503-42) and of Henry Howard, Earl of Surrey (1516-47). Though the selections were written before Elizabeth's reign, they unfolded already the characteristics of the new age. The sonnets, modeled after Petrarch or translated from him, foretold the later sonnet fashion, with its heavy draughts upon the Italian spring; the imitations of classical poetry showed that the English writers had found the feeding root of the Renaissance itself; and the translations as a whole pointed in the direction of the more notable transferrings of the world's imagination to English, Golding's (1536?-1605) Ovid, 1567, and Chapman's (1559?-1634?) Iliad, 1598, and Odyssey, 1616. So also the lighter lyrics, the best of them by Wyatt, foretold the song-books; Surrey's sonnet to Clare and his poem on Windsor witnessed the vitality of the Elizabethan theme of friendship—the nearness of the living incident in his verse; and Grimald's (1519-61?). 'The Garden' prophesied at long range the love of English country life that was to find noble expression in Marvell and Walton.

The fame of Tottel's book made the miscellany a fashionable vehicle of publication throughout the Elizabethan age, though the growing habit of general publishing tended to diminish its importance. 'The Paradise of Dainty Devices' (1576), is interesting for the work it preserves of Richard Edwards (1523?-66), of Edward de Vere, Earl of Oxford (1550-1604), and of Sidney's friend, Sir Edward Dyer (—?-1607), whose fine "My mind to me a kingdom is," appears in this anthology. 'A Gorgeous Gallery of Gallant Inventions' (1578), illustrates the fashion of translation, and bears witness, in the names of tunes for the poems, to the growing invasion of poetry by music. 'A Handful of Pleasant Delights' (1584), is a weaker anthology, of practically no merit, but 'The Phoenix Nest' (1593), is noteworthy for the elegies on Sidney—one by Sir Walter Raleigh (1552?-1618), and for other poems by Raleigh and Thomas Lodge (1558?-1625). 'England's Helicon' (1600) includes selections from Sidney, Spenser, Breton, Lodge, Peele and Barnfield the great writers of the first Elizabethan period, strongly marked by the pastoral vein; the book would be notable for one poem alone, Marlowe's "Come live

with me and be my love." 'England's Parnassus' and 'Belvidere, or the Garden of the Muses' (1600), are mere collections of quotations; 'Davison's Poetical Rhapsody' (1602), is of little more importance, though its selections reflect the sonnet vogue. An earlier and more important book, 'The Passionate Pilgrim, by William Shakespeare' (1599) is clearly a miscellany, as only part of its contents, some songs from 'Love's Labour's Lost' and some sonnets, are by Shakespeare.

In subject matter the earlier part of the Elizabethan age was pastoral, following the tone set by Sidney's 'Arcadia' (1590). This Elizabethan pastoral, literary and artificial as in Sanazzaro and other Italian models, left its impress on the incidental songs in the prose romances. Sidney himself was the most zealous experimenter in classical metres, in the general attempt that Gabriel Harvey fostered, to bring English verse under the laws of Latin prosody. Green and Lodge, the great writers of prose romance after Sidney, were less pedantic in their lyrics, yet their songs have the idyllic method of the pastoral, the method of painting.

The best representative of this pastoral period is Edmund Spenser (q.v.). His first book, 'The Shepherd's Calendar' (1579), was an imitation of the Virginitic eclogue, with the same bookish flavor—here increased by Edward Kirke's commentary—and with the same allegorical treatment of contemporaries and events under the pastoral mask; but with an English setting and with English ideals that stamp the book as native. In 'Th Faërie Queene' (1590-96) and the 'Amoretti' (1595), Spenser speaks also through the pastoral convention—that subduing of all things to loveliness, which is the mark of the world of the Sicilian Muses. The 'Faërie Queene' especially, as might be expected from its ancestry in the Italian romantic epics, has the irresponsibility of pastoral romance—the arbitrary management of the facts of life as if those facts themselves were a flexible language. The paradox of the Renaissance, of Elizabethan literature, is illustrated here on the largest scale, in the gorgeous, archaic language, the unreal, un-English world of the story on the one hand, and on the other the stern English fibre of the ground theme. This same blending of Italian imagery and expression with English spirituality is seen in the 'Epithalamion' (1595) and in the 'Prothalamion' and the 'Four Hymns' (1596).

The pastoral convention, molded by Spenser, remained popular, though less characteristic, in the succeeding decades. Michael Drayton (1563-1631), remembered now for his splendid 'Battle of Agincourt' (1605), and for his great sonnet, 'Since there's no help' (1619), wrote much in the Spenserian pastoral, as did William Browne (1591-1643). In another way also the pastoral habit of beauty was transferred to poems not strictly pastoral, such as Shakespeare's 'Venus and Adonis' (1593), 'Lucrece' (1594), and Marlowe's 'Hero and Leander' (before 1593), where the convention of old-world beauty blends with the Elizabethan zest for a story, evidenced more popularly in the broadside ballads. The tradition of narrative poetry was strong throughout the Tudor period, from the 'Mirror for Magistrates' (1559) to Drayton's 'Barons' Wars' (1603).

As the first period of Elizabethan poetry is



pastoral, so the second period, roughly from 1590 to 1600, is marked by the sonnet fashion. The Italian sonnet had been introduced in detached imitations and translations by Wyatt and Surrey but the fashion of sonnet sequences was set by Sir Philip Sidney's (1554-86) 'Astrophel and Stella,' published in 1591, but known much earlier. Sidney here followed Petrarch, after the example of the innumerable French sonneteers. His sonnets, however, derive vital and individual interest from the circumstances of his own love for Penelope Devereux, a passion as famed among his contemporaries as Petrarch's love for Laura. His poems have had the not unprecedented fate of being called merely literary in their inspiration, and it cannot be denied that his borrowings were probably many; yet in the mediæval way he considered himself sincerely original, and much in his work supports the claim. The amount of actual incident that he takes over from his own life is large, especially in the noble sonnets that deal with horsemanship and knightly exercise, and his story in one point was radically different from Petrarch's or Dante's. His love was known and returned; the bar between Penelope and himself was one of honor, since she was married to another; this lofty sense of this kind of honor was Sidney's characteristically English contribution to the world-theme of love.

In most cases the "love passionings" of Sidney's imitators were of the head rather than of the heart. This undeniable note of artifice has led to serious doubts as to the sincerity of the greater sequences—Sidney's, Spenser's and Shakespeare's. With due allowance for the undoubted imitations in all three poets, it remains true that their sonnets, as distinguished from others, have the very tone of sincerity. It would be an interesting question, though hard to answer, whether through the impress of similar ideals of love and courtly behavior, the poets in England and their fellows in France had not acquired for the moment the same channels of thought—whether the similarities in their work are not frequently coincidences rather than borrowings.

Sidney's 'Astrophel and Stella' had been preceded by Thomas Watson's 'Hekatompathia' (1582), a series of pedantic poems on love themes, which had the respect but not the imitation of his contemporaries. In 1592 appeared Samuel Daniel's (1659-1731) 'Delia,' in honor of the Countess of Pembroke, Sidney's sister—a finely written series remembered for some charming lines and for the oft-imitated "Care-charmer Sleep," itself an imitation from Desportes. 'Parthenophil and Parthenophe' (1593) by Barnabe Barnes (1569-1609), though it contains in its enormous mass some poems of charm, is clearly literary in inspiration. Lodge's 'Phillis,' in the same year, reverts to the pastoral background of the romances; the sonnets have the same charm as Lodge's incidental lyrics.

Spenser's 'Amoretti' (1595) record his own love story, and should be read with his beautiful wedding song, the 'Epithalamion.' The sonnets exhibit almost in excess his sweetness of language and his idyllic, picture method; there is an all but fatal smoothness of surface that makes the thought elusive. But the noble tone, the Platonic emphasis on beauty of

soul, indicates the true Spenser, and the sonnets rank third among Elizabethan series.

Shakespeare's 'Sonnets,' printed in 1609 but written much earlier, mark the supreme reach of this kind of writing. Some of the attention they have received comes from the poet's greater fame as a dramatist; some of it comes from the mystery that still on many sides envelops the sonnets; but the story itself, the conflict of the two angels of friendship and of dark love, is the most striking of the sonnet themes, and the powerful directness with which the subject for the most part is treated places the series above anything else of its kind in English. Natural as the sonnets seem, however, and spontaneous as the themes appear, yet comparison with other sequences shows that Shakespeare assimilated much of his predecessors; how much of his own life is in the story remains the puzzle of his biographers.

In the years immediately following the sonnet-writing, the characteristic vehicle of Elizabethan non-dramatic poetry was the song-book. The manuscript miscellanies of Henry VIII's time had contained the notes as well as the words of songs, and the Elizabethan period was rich in musicians as well as poets. In 1588 Nicholas Younge published his 'Musica Transalpina,' a collection of Italian madrigals with English words. The madrigal was a strict musical form, a contrapuntal part song, built up on many repetitions of a musical theme, and so needing few words—only a short poem, or part of a longer one. With the development of the lute and the growing popularity of lute music, came the song built on a melody, with harmonized accompaniment—what the Elizabethans called an Air. John Dowland, the greatest of the lutanists, introduced this new kind of song in 1597, in his 'First Book of Songs or Airs,' and the form was perfected, in both words and music, by Thomas Campion (—?-1619) in several books of Airs. As the Air was but a short melody, repeated without change, it needed for words a short lyric of several stanzas. This need encouraged the composition of short, finely wrought songs, frequently in the lighter vein, such as Campion himself wrote, and such as became a model for Herrick (q.v.).

Beginning with Wyatt, there had been a vein of satire in Elizabethan poetry. Gascoigne (1525-77) in his 'Steel Glass' (1576), Lodge in his 'Fig for Momus' (1595), Joseph Hall in his 'Virgidemiarum' (1597), and Marston in his 'Satires' (1598), and many lesser writers, kept the tradition alive. One other minor strain, which was destined to flower later into larger expression, was religious verse—often crude and moralizing, as in the miscellanies, often fantastic, as foreshadowing Donne (q.v.), but often devout. In Robert Southwell (1561-95), this writing becomes passionate and of the first quality. His 'Saint Peter's Complaint' (1595) contains that one poem, "The Burning Babe," that Ben Jonson preferred to all his own work.

These are the main forms of Elizabethan non-dramatic poetry. If we except the 'Faëric Queene,' the genius of the age is perhaps best seen in the drama. But in these other forms the Elizabethan mind preserved for us a broad and varied record of its amazing power to absorb the literary past, and to feel deeply its own experience. See ENGLISH LITERATURE; ENGLISH

LITERATURE — MIDDLE PERIOD, and consult works there referred to.

JOHN ERSKINE,  
*Adjunct Professor of English, Columbia University.*

PROSE.

Elizabethan prose has neither the significance nor the splendor of Elizabethan poetry. The greatest masters, Sidney, Lyly, Hooker, have no supreme interest of matter or style; and Bacon belongs in spirit to another age with other ideals and another *ethos*. But the shaping of English speech as an instrument for the science and thought of the 17th century was the result of the efforts of Elizabethan prosemen. Before the period itself commences, the work of More, Elyot and Latimer, of Coverdale, Tynedale and the editors of the English Prayerbook, had already brought a simple and vigorous vernacular into being; but the ancestors of Augustan prose were the group of Cambridge scholars, Cheke, Wilson and Ascham, whose writings, with the exception of the 'Scholemaster,' antedate the accession of Elizabeth. This group devoted considerable attention to the study of English rhetoric; they aimed at plainness and purity of speech and the formation of a literary vernacular in emulation of the classics; they objected to archaisms and affectations of all sorts, and Wilson's condemnation of "ink-horn terms" is one of the significant *loci* of English criticism. The introduction of classical studies as a result of the revival of learning had necessitated a complete revision of the mediæval curriculum, and Ascham's 'Scholemaster,' published posthumously in 1570, follows the fashion set by the humanists of Italy, France and Germany, in a very large number of pedagogical treatises. Like these humanists, it was his purpose to indicate the education necessary to a cultivated gentleman. His own prose style is simple and direct, borrowing the more inconspicuous excellences of Latin prose. But his mood is in some respects that of the Puritan; and in his suspicion of romance and of the growing Italian influence, he is at odds with the whole spirit of Elizabethan life and letters. Prose and poetry alike were to be saturated with the Italianate spirit which he contemns.

Ascham is in some measure the father of that whole school of Elizabethan stylists, whose model was "eloquence" in the classical and humanistic sense, and who disregarded the ornate and "aureate" tendencies of Continental prose. The full and rich notes of Hooker are the final culmination of this manner. The first four books of the 'Ecclesiastical Polity' were published in 1594: several schools of *Novella Elocutio* had intervened since the composition of the 'Scholemaster,' but they have not affected the purity and directness, the calm and judicious argumentation of Hooker's style and manner. In this great book, moderation and passion temper each other after the fashion of the best Latin prose; and Hooker realizes the ambitions of the earlier English humanists who had made this their ultimate goal. Other models and other ambitions could alone make it possible to arrive at a higher standard than that which Hooker achieves at his best. Much of the book is unreadable to-day, like the technical arguments of the Attic orators; but its soaring

passages, like theirs, are monuments of the race and religion whose ardor and conviction they express.

Directness and vigor were also put to far different uses both in secular and in religious polemics. Of the latter, the Martin Marprelate Controversy relating to the problem of church discipline, which raged between 1587 and 1590, gave opportunities which secular pamphleteers only too soon made use of. The significance of 'Hay any work for Cooper?' and 'Pap with a Hatchet' has been greatly overrated; in them the instrument which the Cambridge group had prepared for use was blunted and used as a cudgel. Nor can much more be said of the controversial writing of Nash, Greene and Harvey, in which is illustrated the nearest Elizabethan approximation to modern journalism, but with manners and morals untempered by a wholesome or cultivated public opinion. Other miscellaneous writings of these men, and of Dekker, Breton and others, are concerned with every variety of subject, and their models include Aretino, Rabelais, Dede-kind, as well as other Continental writers of a wholly different type.

Literary criticism began in this period and employed for the most part the prose style whose tradition goes back to Ascham. In content and structure its models were Italian, either directly or through the French; and its significance consists in the fact that it was the means of introducing literary ideals which had been current in Italy for nearly a century. The group of the Areopagus, which parallels the *Pléiade* of France in a few more or less important respects, found its highest critical expression in the 'Defence of Poesy' of Sir Philip Sidney, written about 1580, and published posthumously in 1595. Sidney's ideals of prose style are not those of Ascham, but his practice here is without those excesses and affectations which in the 'Arcadia' furnish the model for a whole school of imitators. His book is an impassioned apology for the poetic art against the onslaught of the Puritans; but the objections which it refutes are universal, and its answers to these questions have in themselves, too, the temper of universality. There are parallels for all its ideas in the almost contemporary works of Frenchmen and Italians. They, too, from the dawn of the Renaissance, as in Boccaccio's 'Genealogy of the Gods,' which Sidney doubtless knew, had written defenses of poetry; but Sidney's is an English book, and in its passion, unity and general spirit seems the native product of Elizabethan genius. Puttenham's 'Arte of English Poesie' conforms more to the model of the formal treatises which the Italians devoted to the theory and practice of poetry. Its purpose, like theirs, is to consider the whole range of criticism; it deals with the history, dignity, forms, metre and ornaments of poetry, continually illustrating the theory both by example and by anecdote. The critical work of Jonson belongs to the Jacobean age, and its ideals and its style indicate the great changes that had taken place since the 'Defence of Poesy.' It is impossible to date the 'Discoveries' with any degree of certainty, but no word it contains antedates the death of Elizabeth. Jonson, despite the fame of this work, enunciates no single

original idea in regard to the art of literature; but the luminous utterances of the later Latin rhetoricians, and the rational classicism of the Dutch critics, are alike embedded in his robust prose, and become an influence on English criticism even after the Restoration.

The formal treatise or preface was the vehicle of criticism in the Elizabethan Age; the chief vehicle which it was to use in future was introduced into England by Bacon at the very end of the 16th century. Montaigne is the father of the modern essay; and to him Bacon owed the name and a number of definite ideas. But in everything else no two works could differ more than theirs. The air of loquacity, the personal anecdote, the amused curiosity, the vivid imagery of Montaigne are not to be sought for in the essays of Bacon. The statesman utters his brooding thought in curt and clipped sentences; Seneca and Pliny here speak English; and the sententious manner enters our speech, destined to saturate prose and verse, and resulting after many changes in the pointed couplets of Pope. Each sentence is its own world and has its own message. Bacon, even in his scientific work, has been called a mere phrase maker by a modern scientist whose distinction in this respect is not unlike his own; in the essays this power is unrestrained by the need of argument and experiment. Emerson is the great American example of this dogmatic use of the disjointed sentence, and like Bacon he, too, has fed deeply on the thought of Montaigne.

A wholly different ideal of prose style, disdaining directness and simplicity, was current throughout the Elizabethan Age, and found its most natural expression in the novel. Fenton's version of Bandello, adapted through the French, and the varied collection of Painter's 'Palace of Pleasure,' introduced the Italian *novella* into England. Their interest is almost wholly in the story, and Herodotus and Boccaccio are made to speak the same language of fiction. In Pettie's 'Petite Pallace of Pettie his Pleasure,' which is modeled on the work of Painter, a new element intrudes itself, and the style which culminates in Lyly may be said to have been inaugurated. The sources of Euphuism have been sought in individual works of Continental literature, notably in those of Guevara; but modern scholarship finds in it simply one manifestation of a disease which was rife throughout Europe at this period, as a result of the disintegration of Humanism. The excesses of the Ciceronians find a parallel in the antithetical balance of Lyle's sentences; and the absurd imagery was a natural result of a literature which had exhausted its content and sought for originality in affectation of manner. This explains the kindred writings on the Continent; and although English prose was young, it could not fail to be affected by these influences. The well-known marks of euphuism, the so-called "parisonic antithesis," the "unnatural natural history," and the like, may all be explained on these grounds. 'Euphuies' itself is in some senses a novel of psychology and character rather than of incident; but its chief purpose is the fashioning of a perfect gentleman after the manner of Castiglione's 'Courtier.' Here Lyly's purpose meets Spenser's; and 'Euphuies' may be considered as the connecting link between the purely pedagogical

treatise like the 'Scholemaster' and the final poetic idealisation of Renaissance education in the 'Faërie Queene.' The vogue of Euphuism is indicated by the number of its imitators; but it is unnecessary to consider the forms which Euphuistic romance assumed at the hands of Lodge, Greene and others.

Sidney is credited by his contemporaries, notably Drayton, with having put an end to this fashion; but if the 'Arcadia' is referred to, it can only be said that one affectation has succeeded another. The 'Arcadia,' which has come down to us as a large, posthumous fragment, is the chief representative in English of the pastoralized romance. It owes much to Herberay des Essarts's French version of the 'Amadis of Gaul,' and something to the 'Diana' of Montemayor; in it the Renaissance transmutations of Greek romance find a climax. The mannerisms of Sidney's style are not those of the archaic or affected word, nor of "unnatural natural history," nor of alliterative antithesis; but the exaggerated imagery, the pomp, the prettiness of the Spanish romances are mingled in the 'Arcadia' in an inextricable jungle of sentence and paragraph. Its vices are those of *conceptismo* rather than of the parallel Spanish vice of *culteranismo*. The mild and modulated Ciceronianism of Hooker, and all of Latin *eloquentia* that Cheke and Ascham had hoped to introduce into English speech, are wholly absent. The 'Unfortunate Traveller' of Nash may be mentioned as an indication of a tendency antipodal to the chivalric pastoralism of Sidney; it introduces in a racier style a picaresque experiment in English fiction between the period of 'Guzman' and 'Lazarillo.' But the novelist and the preacher in general succumbed to the temptations of the ornate style: the novel throughout the period of its origins was tainted with Euphuism or Arcadianism, and pulpit oratory acquired a definite mannerism, which persisted until Eachard, Glanvill and other pamphleteers ridiculed it out of existence.

With the accession of James I Jacobean erudition and science superseded the creative impulse of the Elizabethans. Bacon and Jonson represent the new sententious manner at its best; other writers lose themselves in a sea of detail; still others add a hectic fervor to thought or feeling. But these things do not properly belong to the Elizabethan spirit. The opposition of the vernacular and ornate styles; the inauguration of formal criticism and prose fiction; the passion for controversy; these are the main impulses of Elizabethan prose.

**Bibliography.**—Jusserand, 'Histoire littéraire du Peuple Anglais' (Vol. II); Saintsbury, 'Elizabethan Literature' (London 1887); Smith, G. Gregory, 'Elizabethan Critical Essays' (Oxford 1904); Child, C. G., 'John Lyly and Euphuism' (Erlangen 1894); Jusserand, 'The English Novel in the Time of Shakespeare' (London 1890); 'The Cambridge History of English Literature' (Cambridge 1913); Raleigh, 'The English Novel to Waverley' (New York 1894); Landmann, 'Shakespeare and Euphuism' (New Shakespeare Society Publications, 1880-85, Ser. I, No. 9); Spingarn, 'Critical Essays of the 17th Century' (Oxford 1908-09), and 'Literary Criticism in the Renaissance' (New York 1899); Einstein, 'Italian Renaissance in England' (New York 1902); The studies of

John Lyly by R. Warwick Bond, Feuillerat and Croll; Lee, 'French Renaissance in England' (New York 1910). See ENGLISH LITERATURE; ENGLISH LITERATURE—MIDDLE PERIOD; LITERATURE, and consult works referred to under those headings.

J. E. SPINGARN,  
Major, Infantry, U. S. A., formerly Professor  
of Comparative Literature, Columbia Uni-  
versity.

**ENGLISH LITERATURE, Victorian Period.** The name "Victorian" is popularly given in honor of the late Queen Victoria (1819-1901), and the literature designated by that adjective is roughly coincident with her reign (1837-1901), and is limited to England. The death of Scott (1832) is commonly taken as the most convenient date for fixing the term to the brilliant literary movement of the last years of the 18th century and the early decades of the 19th: and, from this point of view, Victorian literature stands for the new literary impulses that succeeded the decline of the great work of Burns, Cowper, Wordsworth, Coleridge, Byron, Shelley, Keats, Scott and their contemporaries. The literary movement of the Victorian period may best be defined by the main tendencies in poetry, prose and the drama.

#### POETRY AND PROSE.

**Poetry.**—The first, the most popular, and the most prolific poets of the period were Alfred Tennyson and Robert Browning. Three main interests may be observed in their work and that of their contemporaries and successors. The ideal interest in humanity, best represented in the preceding epoch by Shelley, found its most vivid expression in Browning, whose work, at first written under the spell of the great lyric poet, early took on those traits of vigorous interest in the experiences of mankind which are the source of its originality and popularity. Browning's poems are distinguished for their pervasive feeling for the moods and the experiences of many people of all ages and for the dramatic vigor of their expression. In these respects he represents a very important movement of the century, and many of the same characteristics inform the poetry of his wife, Elizabeth Barrett Browning.

In the second place, the serious moral poetry of Wordsworth, the poetry "of man, of nature and of human life," justly celebrated as one of the chief glories of English literature, had a legitimate successor in the grave, reflective poetry of Matthew Arnold and Arthur Hugh Clough. They began writing a few years later than Tennyson and Browning. Like many of their contemporaries, of whom they are the best mouthpieces, they were oppressed by the melancholy of life, and, to a greater degree than their literary prototype, they deal with morals, with duty, with the vanity of human effort and with "the eternal note of sadness." Their poetry, particularly that of Arnold, is brilliant in style and finely finished, and a high place is accorded to them as exponents of the graver and more solemn side of the poetry of the century. Their temper is expressed in a more sentimental strain in such poets as Arthur O'Shaughnessy.

Contemporaneous with the decline of this impulse, which spent itself in the endeavor to

express some solution of the enigma of existence, there arose the third school of poets, who, foregoing this quest, gave themselves up to the search for beauty of form and sentiment, who busied themselves with the retelling of old tales, who were concerned with romance, and who strove, for the most part, to recreate a picturesque and ideal world. Three names stand out conspicuously; the painter-poet, Dante Gabriel Rossetti; William Morris, poet, story-teller, socialist and manufacturer; and Algernon Charles Swinburne. With them is to be named Christina Rossetti, sister of D. G. Rossetti.

In some respects, Tennyson more than any other poet of the century is representative of these three groups. Beginning, in his first volume (1827), under the spell of Keats, he had within a decade produced much original work and by 1860 established his reputation as the best-beloved poet in England. In much of his earlier work, he treated subjects from human life not unlike those of Browning, though with more calm and repression and less lively vigor. The ethical ideas of his time found, as in Arnold and Clough, a current and lasting expression in many of his shorter lyrics, such as 'The Two Voices' and 'Locksley Hall,' as well as in the longer 'In Memoriam' (1850) and as 'Idylls of the King' (1858-). Throughout his poetical career, Tennyson was a most distinguished and careful workman, and in this respect he is akin to the poets who were spoken of in the third group, as, like them, he is, in some respects, a teller of tales. Unlike them, however, an ethical and not chiefly an æsthetic motive is dominant in him.

Besides these chief poets, there should be mentioned William Barnes, the painter of the homely life of Dorsetshire; two distinguished writers of *vers de société*, Frederick Locker-Lamson and Charles Stuart Calverly; Tennyson's own less celebrated brothers, Frederick Tennyson and Charles Tennyson Turner, Coventry Patmore and many other poets who have written in a touching way of simple things; and above all, Edward Fitzgerald, whose translation of the 'Rubáiyát' of Omar Khayyám is not only classical in its finish but also not unrepresentative of much of the melancholy of the poetry of the century. Of contemporary English poets, the greatest amount of popular fame has fallen to Mr. Rudyard Kipling.

**Prose.**—Important as is the poetry of the era, it is many ways surpassed by the amount and richness of the prose. During the period the great popular form of imaginative literature was the novel. Sir Walter Scott, in the preceding part of the century, did more than any one else in the history of English literature to establish the widespread vogue of fiction, and in the field of historical romance he remains an object of the detracting envy and real despair of his successors. The main development of the novel in the Victorian period was, however, along a different line from that established by Scott, whose more immediate successor, Edward Bulwer-Lytton, a prolific writer, marked a decadence of the romance from the standard of the great master. Rather the novel developed according to the principles laid down and exemplified by the great writers of the 18th century, Richardson, Fielding and Smollett, and brilliantly carried on in the early 19th century

by Maria Edgeworth and Jane Austen. Accordingly the great fiction of the Victorian period is largely realistic in tendency. The most brilliant and most popular, as well as the earliest of the men of the period, was Charles Dickens, who, in the type of story and the method of narrative, followed the school of LeSage and Smollett, but added to the English novel, considered as a whole, a new kind of buoyant humor and a warm and polemic hatred of wrongdoing and oppression. Almost contemporary, though flowering later and declining earlier, was William Makepeace Thackeray, often spoken of as the chief of English novelists. Like that of Dickens, his material was largely drawn from contemporary life, but he wrote of higher social strata, and viewed his world more as a panorama, calmly and with less personal intensity and less polemic sense. Almost contemporary with the finest work of these masters, was represented a very different and highly original impulse in Charlotte Brontë, whose 'Jane Eyre' (1847) is the prototype of the intense personal novel from time to time in vogue.

Of the types of material furnished by these novelists, that represented by the humanistic novels of Dickens was the most conspicuous in the group of slightly less great novelists of this early Victorian period. The purposeful spirit found a very interesting expression in the religio-historical, and modern ethical, novels of Charles Kingsley, the gist of whose teaching is that no earthly happiness exists, save in the surrender of self to the faith of Christianity (understood in an Anglican sense); in Elizabeth Gaskell, whose classic and charming 'Cranford' (1865) is less representative of her interest in social questions than such earlier novels as 'Mary Barton' (1848); and in the vigorous and voluminous Charles Reade, who, besides being a writer of historical fiction, was also a vehement champion of the oppressed and a challenger of injustice. These writers were, in many respects, akin to Dickens. The most distinguished representative of the more realistic school, in many respects a follower of Thackeray, was Anthony Trollope, a writer of pleasant stories of English life, and one of the most consistent of the realists.

Charlotte Brontë and her sisters may be called specialists in representing emotional intensity. The term "specialist" may also be applied to several writers of the early Victorian period. Frederick Marryat was a specialist in the writing of sea-stories, and some of his nautical creations are famous. Charles Lever dealt chiefly with the military hero. An interesting picture of the out-of-the-way life of peasants and gypsies is to be had in the works of George Borrow. A popular writer on school and college life was Thomas Hughes. There may be named also Benjamin Disraeli, G. P. R. James, Samuel Lover, and of a somewhat later period, contemporary with George Eliot, Richard Doddridge Blackmore and Margaret Oliphant.

Since the time of the great panoramic novelists of the early Victorian period, the novel has tended to specialization, such as has been described, though of a larger kind. Among writers belonging to the so-called later Victorian period, stands out the name of the great specialist in states of the human mind, in questions of

duty, in ethics, "George Eliot" (Marian Evans Cross). Though in one or two novels, as 'Middlemarch' (1871-72), she attains the panoramic view and produces classical types, her interest was chiefly centred in the problems mentioned, which she illustrated, for the most part, in the lives of people of humble and rural circumstance. Her artistic aim was to make interesting the life of the lowly. Contemporary with her, but continuing his production down to a much later date, was Mr. George Meredith. In a series of powerful novels, he exhibited various phases of human temperament, and has tried to express what is most native and fundamental to human action. He was the foremost living English novelist of the day with the possible exception of Mr. Thomas Hardy, who is still with us; the latter however, has, in a long series of brilliant novels, been less concerned with the problems of the individual soul and the expression of types of human temperament, than with the workings of an external and unaccountable chance and caprice in human destiny, and in this respect, as in his beautiful pictures of rural life, Hardy also is a great specialist. With them, in a totally different field, that of the romance built on the tradition of Scott, but embodying more allegorical and figurative elements, is Robert Louis Stevenson. The most brilliant and popular work of Mr. Rudyard Kipling also belongs to this period.

Quite as important and striking as either the poetry or the fiction of the Victorian period is the large body of humanistic, critical and scientific prose that is regarded by Victorian writers as among the chief glories of English literature. During the period, the essay form, owing largely to the growing prevalence of magazines and reviews, was, and still is, in vogue, but it was used more and more widely for other than strictly literary purposes. There have been practically no important successors of such essayists as Lamb, Hazlitt and DeQuincey (who, like Landor, falls also within the early Victorian period). The ancestry of the literature of 1830-1900 is rather to be traced back, in humanism, to Burke and the French Revolution, with some diffusion and dispersion; in criticism, to Coleridge; in history, to Gibbon; in economics, to Adam Smith and Bentham; in science and philosophy, to Hume and Bentham; with the infusion, from time to time, of ideas from Germany.

This last was the initial source of inspiration of one of the greatest humanists of the century, Thomas Carlyle. Beginning with translations of German writers and essays and excursions into German ideas, Carlyle, not far from the opening of the reign of Victoria, became at once the prophet and the scourge of his countrymen. Moved by the same spectacle that had stirred Dickens and Kingsley, he proceeded somewhat illogically but very eloquently to demonstrate the futility of contemporary institutions, to decry the impotence of the democracy, and to point out the one way of salvation, the dominance of the "hero" whom he illustrated in several important works, as 'Heroes and Hero-Worship' (1841); 'Cromwell' (1845); and 'The History of Friedrich I' (1858-65). It would be wrong to say that the mantle of Elijah fell upon the Elisha of John Ruskin, for the careers of the two overlap

by many years. But Ruskin continued vehemently the task of upbraiding his countrymen for their failure to observe what was of good report. Starting his career as a critic of art, and trying to reform the taste and the æsthetic manners of the time and to lead his readers back to a true idea of the beautiful and the good, he, by the middle of his career, 'Unto This Last' (1860), broadened the scope of his interests so that they included economic and social, as well as literary and artistic, questions. His influence has been very widely diffused, like that of Carlyle, and their contemporary humanist, Emerson. A third great chastiser of the evil which men do and think was Matthew Arnold, already mentioned as a poet. From about 1870 to 1880, his literary energies, originally devoted to poetry and next to literary criticism, were directed toward trying to make his stubborn island countrymen think rightly on political, literary and religious matters in accord with that formula which he continually characterized as "culture."

With these spiritual guides is to be named the great humanist, the friend and contemporary of Carlyle, John Stuart Mill, who, besides being an admirable technical student and expounder of logic and political economy, attempted to disseminate the principles of moderation, of justice, of right reason, and in all his works, as in his famous essays 'On Liberty' (1859) and 'The Subjection of Women' (1869), sowed the seed of righteousness. For a discussion of Mill's work as an economist and a philosopher, the general articles and the special article on Mill should be consulted, since it is out of the province of the present article to touch on scientific studies of the century except in so far as they relate to literature.

The humanistic movement in its earlier phases is often regarded as an aspect of what is called, for the purposes of classification, the romantic movement, the impulse, that is, which expressed the desire for individual expansion rather than the submission to the limits imposed by authority, and which implied the manumission of the human spirit and intellect from current and traditional bonds. In the religious field, the so-called Oxford Movement of 1833-41 is sometimes called romantic in that it was the work of a few young men who revolted at the religious custom of the time and endeavored to re-establish an earlier, and as they conceived it, a purer form of belief and worship. The Oxford Movement received at once its best exposition and severest criticism in the controversial autobiography of the originator of the movement, 'The Apologia Pro Vita Sua' of John Henry Newman, written in defense of his conversion to Catholicism. Newman stands in English literature as one of the great masters of finished prose of a formal but winning cast and as a specialist in somewhat technical religious controversy. The orthodox Anglican feeling of the time is best represented in the sermons and writings of Frederick Denison Maurice, Frederick William Robertson and Charles Kingsley, the novelist.

The more strictly critical movement, as related to literature, goes back to Coleridge and Germany. The dogmatic manner and air of finality which distinguished the pronouncements of the Edinburgh and Quarterly reviewers,

found its descendant chiefly in the common-sense criticism of Macaulay. Most of the critics of the early decades of the century, Lamb, Hazlitt, De Quincey and others, were, in one way or another, frankly personal or deliberative rather than ex cathedra in their attitude, and in Coleridge criticism tended to the ascertaining and expounding of principles rather than the assertion of dogmas. The early work of Carlyle, the next important critic after the group just named, was largely critical, and it busied itself with the exposition and interpretation of Schiller, Goethe, Richter and other contemporary German writers, for the benefit of his countrymen. Carlyle, however, was too busy exploiting the doctrine of the "hero" and sounding the sins of his fellow men to become a literary critic of lasting influence. The main stream of critical tendency, up to the time of the modern scientific and philological schools, had sprung from the stimulating power of the German-derived Coleridgeanism. The chief tenets of that influence were the casting aside of authority in favor of appreciation: any work of art contained in itself the reason why it was good: and consequently an author's purpose, his range, his total production and his vogue were things to be taken into consideration. This principle passed naturally in the later Victorian period to the criticism of types, wherein criticism tended to become characterization rather than censure or commendation. Two great critics are illustrative of the tendency: Walter Bagehot (1826-88), unexcelled for the vigor and brilliancy of his characterizations of types of mind and art, and Walter Pater (1839-94), the polished expounder of artistic personality. The same tendencies, with different material and different emphasis, are to be observed in the work of such distinguished modern critics as Leslie Stephen, John Addington Symonds, Viscount Morley (1838-), and others. Matthew Arnold, poet and humanist, second to none in importance as a critic, represents a reaction in favor of a more abstract and ideal standard. Historically important as having done much to enlarge the confines of English criticism and to rid it of insularity, he, nevertheless, was at variance with his contemporaries (as in matters of religion and politics) in asking for more authority and standardization of judgment, which standard is largely a matter of his own predilection.

Much of the critical study of literature during the period was dominated by the historical and the scientific method. That aspect of criticism, except in such invaluable work as Stephen's 'Dictionary of National Biography' and other excellent biographical works, is, however, less important in the field of literature proper than that of history and science. Though these subjects do not properly enter into the present article, they are so important that mention of them cannot be wholly ignored. In history, besides such men as Carlyle, who wrote histories, and Symonds, the historian of the 'Renaissance,' there were, in the Victorian period, since the time of Hallam, such distinguished names as Milman, Grote, Macaulay, Harriet Martineau, Kinglake, Froude, Buckle, Freeman, Gardiner, J. R. Green, Lecky and Viscount Bryce. In philosophy and science the names of Lyell and Spencer are eminent,

and the theory of natural selection as presented by Darwin and expounded by Huxley has profoundly influenced the whole train of 19th century thought since the publication of 'The Origin of Species' (1859).

**Bibliography.**—References are so numerous that it is impossible for the preceding and the following section to make more than a general reference to the lists contained under the articles on the writers specifically named, though such books as Saintsbury's 'History of Nineteenth Century Literature'; Stedman's 'Victorian Poets'; Stopford Brooke's 'English Literature'; Palgrave's 'Golden Treasury' (second series), and G. K. Chesterton's 'Victorian Literature' may be cited.

WILLIAM T. BREWSTER,  
*Professor of English, Columbia University.*

#### DRAMA.

At the beginning of the Victorian period, the English stage was still contentedly supporting the traditions of two preceding centuries. The objects and methods of both actors and plays were practically the same as they had been at the Restoration. In both, the rhetorical style prevailed. The two Patent theatres created by Charles II still had the sole privilege of playing the legitimate drama, and Macready was striving to perpetuate the histrionic tradition which went back through Edmund Kean and John Kemble, to Garrick and to Betterton. The plays themselves still kept, with slight modifications, notably in the direction of morality, to the Restoration models, of comedy which derived from Molière with a slight infusion of Jonson; and of tragedy which was either Elizabethan simple or Elizabethan Restorationized. Since Goldsmith and Sheridan, literature had showed a widening separation from the stage which almost to their time had been its chief mouthpiece. This had been mainly brought about by the great extension of journalism and, later, by the signal success of the novel in the hands of Scott. These two forms of literary endeavor were offering larger and securer returns than play-making, and thus naturally drew away from the theatre men of mark and left only the adapters and the hacks. Such was the position at the outset of Victoria's reign. Dramatic history during her reign is, until the very latter end of it, one rather of movements than of men. The changes which were to take place during her occupation were brought about by social, economic and physical, as well as literary forces; for more than any other artistic activity, the stage is responsive to the conditions under which it exists. These changes embraced the decay of the old traditions, the even wider separation of the stage from literature, the birth of a new drama followed by a partial return of literature to the stage, and finally the growth of a serious conception of the drama as a criticism of life, a conception already achieved by other European nations.

London, during the first 40 years of the century, had more than doubled its population, and, as a result, the Patent theatres were on all sides encroached upon by minor theatres which, in spite of their legal disabilities, proved formidable rivals. When the Act of 1843 abolished the privilege of the Patent theatres, an era of

more active competition began. This competition naturally relied upon display as its best means of advertisement; and the invention of gas and lime-light about the same period—inventions of great significance to the stage—confirmed the universal tendency toward the spectacular treatment of plays. Inevitably there set in the decline of the rhetorical drama, the appeal of which, on a poorly-lighted stage, was primarily to the ear and not to the eye. Meanwhile another cause was contributing not only to destroy the rhetorical tradition but to widen the gap between literary men and the theatre. What small demand there was for original work would doubtless have in time recalled writers from the novel and the newspaper, but unfortunately the demand, just beginning to be felt in the early Victorian period, was checkmated by an outside influence. The Romantic revival in France had suddenly broken away from the frigid classicism, so unattractive to English audiences, and Hugo had ushered in a kind of play which the English found more to their taste. These new plays proved easily imitable and adaptable in London, but the habit of importation did not become wholesale until the advent of Scribe. Scribe perfected the mechanics of story-telling in dramatic form, and in so doing largely deleted everything else from a play—witty dialogue, atmosphere, locality, and characterization. Thus his plays, being simply stories, could be given anywhere with equal effect, and as London managers could get them for nothing, his output and that of his school became an inexhaustible storehouse for adaptation.

The result upon the home product was twofold. It reduced to a minimum the meagre band of English writers, and those that remained no longer even attempted to represent English life and thought. Instead, they provided for the public an impossible *mélange* of French ideas and emotions served up in British dishes. In the second place, the adaptation and imitation of Scribe's methods proved the finishing blow to the moribund rhetorical conception of comedy by bringing in a French realism of mounting and stage-setting. When a stage room had three sides, a ceiling and real doors, many conventions of action and dialogue, unnoticed when an interior consisted only of wings and a back-drop with painted chairs, became ridiculous and unendurable. Thus gradually a new ideal was developed, by which the play was forced to move a little nearer to the life now in a material way presented with considerable reality. Internally, however, the plays remained as artificial as they had been before, their characters puppets impelled by theatrical and absurd sentiments and exhibiting the crudest of psychologies. The main dramatists of the period which this development closes were Bulwer, Tom Taylor and Charles Reade, and Dion Boucicault. Bulwer, under the influence of the Romantic revival in France, produced 'The Lady of Lyons' and 'Richelieu,' and his comedy 'Money' shared the distinction of being the last representation of rhetorical comedy with Boucicault's 'London Assurance' and 'Old Heads and Young Hearts,' with Taylor and Reade's 'Masks and Faces,' and with Taylor's 'Still Waters Run Deep.' Boucicault, the arch-adaptor and plagiarist of the period, had the

good fortune to hit upon a type of his own in his series of very successful Irish plays, but they are no nearer real studies of life than the others of the period. The predominance of Scribe and his school had paralyzed native authorship.

Into this lifeless world came T. W. Robertson—a dramatist whose pleasant work has no great intrinsic value, although he possessed a strain of original genius—to create a new form of drama. It ignored not only the old rhetorical tradition but the new French-English mongrel species. It was merely the comedy of manners, clothed in natural speech and realistic setting, but it seemed absolutely original and spontaneous. It viewed the commonplace social relations from the outside, with a naïveté and humor which disguised to an unsophisticated public the insipidity of its characters and the shallowness of their sentiments. Though he brought new life to the drama, fortunately his school, represented by H. J. Byron and Albery, did not long survive him, else the stage would have found itself in almost as lifeless a way as when he rescued it and with an artificiality different from, yet as great as, that against which he effectively protested.

Though W. S. Gilbert could not be called a follower of Robertson, he made the same protest against the fustian of the stage, and carried on the verbal flippancy which had vied with sentimentality in the latter's plays. So thoroughly original was he that only the adjective Gilbertian can cover the precise blend of wit, delicate fancy, satire and extravaganza, which achieved some brilliant successes on the legitimate stage and which finally secured the aid of musical accompaniment in a long series of comic operas that stand, like their author, in a class apart.

In spite of Robertson and Gilbert, however, the theatre lapsed again into a period of adaptation from France. But there, meanwhile, had sprung up a larger type of social drama than that of Scribe,—a type of which 'Diplomacy' is an illustration,—and imitation of this wider species was less deadening than the former had been. When, however, international copyright was at last secured and French works could no longer be adapted for nothing, the effect of fair play for the English dramatist was seen almost immediately. A group of young writers arose who, beginning as imitators, were soon applying French methods to original and native purposes. Of this group, Mr. A. W. Pinero and Mr. H. A. Jones were pre-eminent. They sought their material at home and, observing carefully, reproduced sincerely. Another decade had to pass in experiment before these men really undertook a drama which evinced anything like a serious psychology and a vital relationship with life. Not until 1890 did they dispense with elementary love-idylls and the kind of story which had been up to that time inevitable to every play, or set out definitely for a more thoughtful and virile drama covering the field of social intercourse. Following their lead, Oscar Wilde and Mr. Bernard Shaw developed the social comedy into a more serious content. Wilde's pyrotechnic brilliance of dialogue and inverted epigram concealed at first his genuine dramatic quality and adroit constructiveness as a playwright.

Mr. Shaw took up the stage as a lively form of presenting himself and his social propaganda, but, though his brilliant plays hardly succeed as drama, there can be no question of their success with the public and as literature. These men with Mr. Pinero and Mr. Jones have once more elevated the English drama not only to the level of Continental drama but of the literature of their own land.

The poetic drama during the reign is represented by Westland Marston, Talfourd, Browning and Tennyson. The formal dramas of the first two are long forgotten. Masterly as are some of Browning's plays, they seem remote from the purpose of the stage, and when some of them got there it was discovered that they could be only recited, not acted: at any rate, they can be successful, if at all, only in the manner of the rhetorical tradition for which they were conceived. Tennyson's plays, although loosely constructed in the loosest of Elizabethan formulas,—the chronicle history,—have been acted with considerable success. This was due, no doubt, to the circumstances of their production, for his fine verse lacks vigor and he has not seized upon the essential moments of his stories, the crucial parts of most of his dramas taking place behind the scenes. In 'Queen Mary' and 'Harold,' however, he presented genuine dramatic material. If the taste for the poetic play can be revived in the future, it must be as drama first and poetry afterward, and drama conceived in a modern rather than Shakespearian type.

ALGERNON TASSIN,  
Lecturer in English, Columbia University.

**ENGLISH MAIL COACH, The.** Thomas De Quincey's 'The English Mail Coach' consists of three sections, the first of which appeared in *Blackwood's Edinburgh Magazine* in October 1849, with the added title, 'On the Glory of Motion,' and with no intimation that more was to follow. In December appeared what the author subsequently, in the collective edition of his writings, called 'Section II, The Vision of Sudden Death,' and 'Section III, Dream-Fugue, Founded on the Preceding Theme of Sudden Death.' It would seem that the 'Dream-Fugue' was composed in 1844 (when De Quincey had virtually conquered the opium habit), and the two introductory sections five years later; these are, then, subordinate to the 'Dream-Fugue,' which is a specimen of De Quincey's rhythmical, "impassioned" prose—the medium which, for his special purpose, he preferred to metre. 'The English Mail Coach' being a kind of sequel to 'The Confessions of an English Opium-Eater,' the 'Dream Fugue,' as the author would have us believe, constitutes one of the poetical dreams, full of beauty and terror, which arose from his indulgence in opium, though based upon actual occurrences in his life. Accordingly, in Section I, his experiences while a student at Oxford, traveling to and fro by coach during the time of the Napoleonic war, are related, with much circumstance and digression, in a less impassioned style; in Section II is recounted an accident on the high road, in which a young man and girl in a frail carriage narrowly escape destruction from the flying mail coach; and in Section III suggestions from these themes are elaborated in a highly ornate style, the "music" of which is in-



deed beautiful, though the value of the content is slight. The allusions to Waterloo, and to the way the news of the battle spread through England, give the document an interest for the historian. Consult Hart's edition of 'The English Mail Coach' (New York 1893); and Cooper, 'The Prose Poetry of Thomas De Quincey' (Leipzig 1902).

LANE COOPER.

**ENGLISH MERCURY.** See CHENOPODIUM.

**ENGLISH PALE**, the name formerly applied to extraterritorial districts in Ireland, Scotland and France, staked off by pales or poles from the surrounding country, marking definite boundaries, these districts being governed by special laws. The pale in Ireland was established in the reign of Henry II; its extent varied under different kings; from the time of Henry VIII until the subjugation by Cromwell, it comprised most of the modern counties of Dublin, Louth, Meath, and Kildare. In 1558 the "English" or "Calais Pale" in France extended from Gravelines to Wissant. An English Pale also existed in Scotland, for a short period under the Tudors. See PALE.

**ENGLISH POETRY, Spasmodic School** of, an epithet first applied to Byronic verse by Carlyle, and subsequently by Professor William Edmonstone Aytoun to a group of minor poets of the middle 19th century. The school was said to include Philip James Bailey, Sydney Thompson Dobell, Alexander Smith, George Gilfillan, John Stanyan Bigg, and according to some critics, Gerald Massey and even Swinburne. The Byronic "weltschmerz," world-pain or cosmic agony, spasmodic strivings after unattainable ideals, discontent with life and its mysteries, sceptical disquietude, vain effort and resentment against unrewarded labors, characterized their writings, which, however, were frequently marked by passages of considerable merit, and were a faithful reflection of a struggling phase of contemporary thought. In 'Firmilian: A Spasmodic Tragedy,' Professor Aytoun in 1854 attacked and parodied the writings of the school with considerable success, ridiculing their subjects and imitating their ponderous style, especially the works of Bailey, Dobell and Alexander Smith. See biographical articles of the writers mentioned and consult Martin, (Sir) T., 'Memoir of W. E. Aytoun' (London 1867).

**ENGLISH SNIPE**, a name frequently used for the common American snipe or Wilson's Snipe (*Gallinago Delicata*). There is, however, an English snipe proper (*Gallinago Gallinago*), which is almost indistinguishable from the former and has its habitat in the north of Europe. See SNIPE.

**ENGLISH SPARROW.** See HOUSE SPARROW.

**ENGLISH TAPESTRIES.** See TAPETRIES.

**ENGLISH VERSIONS.** See BIBLE.

**ENGLISHRY**, or **ENGLESCHERIE**, an old Norman law term, which originated after the invasion of England by William the Conqueror to designate the identity of a person found slain, as a native. If the body was unidentified, the law presumed that the person

was a Norman, vindictively slain, and where found, the community of 100 was fined. If the Englishry of the victim was established, the fine was remitted.

**ENGRAFTING.** See GRAFTAGE.

**ENGRAILED**, a heraldic term used to designate a line made up of concave semi-circles. See HERALDRY.

**ENGRAVINGS.** For humanity's great indebtedness to the art of pictorial reproduction it would be difficult to claim too much. Next in importance to the art of printing, as an aid in the history of the advance of civilization, certainly comes that of illustrating. The growth in the art of the manifold reproduction of pictures is one of great interest, as well as importance, and many books have been dedicated to an exposition of our best engravers and their productions, known to the connoisseur as "prints." And among connoisseurs of art their collections of *prints* hold a very favorable position.

**Etching.**—This process is carried out on a copper plate having its upper surface highly polished. This plate is heated and then coated with an acid-resisting substance, usually a mixture of burgundy-pitch, asphaltum and beeswax. Cold applications of certain pastes composed of materials dissolved in oil of lavender or chloroform are sometimes used. The plate next receives a coating of lamp-black. This prepared plate has the drawing scratched through the surface coating by means of etching-needles. All work is drawn in reverse (*negative*) of the actual desired impression. The back of the plate is next coated with varnish (the process is termed "stopping-out"). Now the plate is immersed in an acid for the process of "biting in." Those lines which are to remain the finest are *stopped out* by varnish early, then the plate is returned to the acid bath to attain the deep black lines. When the process has been carried on till the artist is satisfied with the condition, the varnish and wax are cleaned off and the plate is ready for the press. Next the entire upper surface of the plate is coated with ink, the channels made by the acid being also filled; then the ink on the upper surface is cleaned and a copper-plate press takes an impression (called a "print") on damp paper. *Dry-point Etching* is done by engraving the design directly into the metal with a needle (using no acid). This scratching of a furrow leaves a "burr" (or raised ridge of the crased metal) on either side of the channel; the effect of this burr on the impression is characteristic of a dry-point print. Etching, unlike engraving with a "burin" (graver) is done as rapidly as the genius of the operator permits, and therefore is a process frequently used by painters. Among the early painter-etchers were Albert Dürer, Lucas van Leyden, Vandyck, Rembrandt, Agostino, etc. Rembrandt was the first exponent of the art of etching (17th century) besides producing the grandest work known. Among other well-known early etchers were Van Vliet, Ostade, Paul Potter, etc. In England were Barlow, Gaywood, Hollar, Place; and in France, Callot, Bosse, etc. In the 18th century were Hogarth, Claude Gelée, Guido Reni, Canaletto, etc. In the 19th century were such masters as Ingres, Corot, Méryon, Jacquemart, Seymour Haden, McNeil

Whistler, Joseph Pennell. Most noted of etchings are, probably, those from the drawings of Claude, reproduced by Richard Earlom in the great 'Liber Veritatis' (1740-1822).

**Wood Engraving.**—Here the technique is just the reverse of etching, inasmuch as the parts to appear in black or color are left the height of the surface, while the background (white) is cut away. Our earliest woodcuts are German (middle 15th century) and the practice grew up with the sister art of printing. Albrecht Dürer and Hans Holbein greatly aided the advancement. To the early school of wood engravers belong such names as Lucas Cranach, the Behams, Lucas van Leyden, Altdorfer, Burgkmair, Baldung, Ammon, etc. The 17th century witnessed the decadence of wood engraving, but in the 18th century it was revived. The early workers had engraved on the plank or with the grain; in the revival a modern method of engraving across the grain on boxwood blocks was used. The "white line" now appears, produced by means of making cuts into the wood surface. Thomas Bewick (1758-1828) was one of its earliest exponents. The prints of this period show clearly the merits of the changed system, allowing such delicate treatment. Among its exponents are Whymper, Baxter, Thompson, Linton, Harvey, etc., in England; Vogel, Ungelmann, Kretchner, Pfnorr, Weber, etc., in Germany; the Pannemakers, Yoú, Pisan, Colin, Valloton, etc., in France; Veldheer, Nieuenkampf, etc., in Holland. But another process of wood engraving was brought about by the fact that wash drawings on the block permitted light and shade effect to be engraved through the painting. This soon put the original work in the hands of draughtsmen to be engraved by what soon became an artisan engraver class. Decadence set in and the first half of the 19th century found its art work done in the metal (steel). Periodicals (started by the *Illustrated London News*, in 1842) brought back work again to the engravers as wood engravers, because they could put wooden engravings on the press with the type, whereas the metal plate engraving had to be printed from separately. The Victorian School of wood engravers arose from illustrated volumes on India paper for which such artists as Rossetti, Millais, Hughes, etc., did drawings on the block and "facsimile" work was done by such geniuses of interpretation as the Dalziel brothers and Swain. Birket Foster did fine drawings as did also North, Lawless, Small, Boyd, Houghton, Sandys; even Burne-Jones and Whistler did a few. Noted 19th century wood engravers were Roberts, Thomas, Babbage, Comfort, Cooper, etc. Furnishing drawings from artists quickly led to photographing the picture on the block and reproducing directly (in positive). But wood was not adapted to stand the heavy wear in producing prints on a large, popular scale, hence metal casts were invented to preserve the original (*clichés* they were termed). In America, *Harper's Magazine* and, later, the *Century* helped the cause of the wood engraver and they did better justice to the artists' originals, bringing out the tones displayed in chalk or wash drawing.

**Line Engraving.**—Here the engraving is done by a graver (*burin*) of prism form which scoops out a strip of the metal nearly free from

"burr," and easily scraped. After cutting out all the lines that go to make up the picture, ink is applied, filling up the lines. Then the surface is cleaned and an impression (called a print) is taken on damp paper on the press. Line engraving is a 15th century invention of the Italian goldsmiths, who themselves were artists, and did fine line engravings. In Florence were Botticelli, Baldini, Fra Lippi, Robetta. Andrea Mantegna worked in Padua; Marc Antoni in Bologna; Francesco Francia in Venice; Raimondi in Rome, etc. Clever line engravers in Germany were Albrecht Dürer, the van Mechens, Schöngauer, Aldegrave, Altdorfer, the Behams, Pencz, etc.; and in Holland Rubens and Vandyck, with their pupils. In England were Holl, Pelaram, Payne, Cecil, the Audrans, Nanteuil, Rouillet, etc. Also numerous 18th and 19th century engravers did fine work all over Europe.

**Stipple Engraving.**—This process consists of producing a series of dots so related to one another as to size and distance that the combination produces the desired picture. The usual method is to produce the marks by etching, to be further manipulated with a specially prepared graver. While a pure stipple engraving consists of dots solely, the line engraver frequently used the stippling method to obtain softness in flesh shading. Crayon drawings were in vogue late in the 18th century so that stipple engraving (best suited) was quite common then in reproducing the crayon cartoons of Fragonard, Watteau, etc. The greatest exponents of this style were Francisco Bartolozzi (1725-1815) and his school. Stippling never found much favor on the Continent. Wynne specialized largely on Angelica, Kaufmann on drawings and portraits; other noted names are Bond, Bromley, Cheesman, Blake, Picart, Stoddart, the Holls, Heath, etc.

**Steel Engraving.**—The introduction of soft steel (1822) by Thomas Lupton for engraving mezzotints brought with it two changes. Commercially the plate was more profitable, producing about three times as many impressions as the copper; and the harder metal permitted much more minute and delicate work to be done. To the untrained eye the difference in ordinary line work is very slight. The incision of the tool is less deep in the harder metal forbidding the bold gradations of line that copper permits. In etching the ink does not produce from steel as artistic an impression as from copper and is easily recognizable. In mezzotints the steel medium produces a "thinness" not seen in copper work. Most steel engravings are done by etching and later improved by the graver. The stages ("trial states") through which a steel engraving progresses to a finish are so widely apart that the work was frequently divided among several engravers, each having his special part. This commercialization soon brought decadence, the work becoming mechanical. Work of good merit was done by the following, among others, engravers: Fittler, Heath, Smith, Bromley, Danforth, Doo, Goodall, Raimbach, Holl, Le Keux, Finden, Greatbach, etc. The later invention of giving a steel coating to a finished copper plate engraving made the old medium as commercially productive as the steel, and soon ended the career of the latter.

**Turner Prints.**—The great engravings "after Turner" are generally treated to a special classification. The great painter Joseph Mallord William Turner (1775–1851) did entirely finished engravings himself but in most cases confined himself to outlines of the reproductions of his own drawings, and left the continuation (always under his close supervision, however) to other engravers. "Turner prints" range from 1794 to 1856 (five years after his death). The most noted collection is a series of 71, engraved for his great 'Liber Studiorum.' Assisting him were such engravers as Basire, Pye, Dunkarton, Clint, Lupton, etc. Turner's medium was mezzotint. Another noted series is his 'Southern Coast,' Whitaker's History of Richmondshire, etc.

**Mezzotints.**—In this process the plate is given an immeasurable number of small "burrs" or sharp projections. This work is termed "grounding" and is done with a "cradle" or "rocker," an instrument consisting of a curved blade similar to a cheese cutter. This is *rocked* from one side of the plate to the other and its teeth create a jagged line (termed "way"). Starting at the top the "ways" are made in parallel till the last one reaches the bottom of the plate. Next these rough lines are made from top to bottom, at right angles to the last ones, then others are done diagonally at every possible angle gradation. The picture is produced on this roughened surface by tooling away the burrs for the lights with a "scraper"; the high lights being next brought out by polishing parts with a "burnisher." The method allows great delicacy in "tones" closely similar to those of a painting. The process was invented by Ludwig von Siegen (1640). Noted mezzotint engravers were Sherwin, Place, Blooteling, Vandervaart, Beckett, Faithorne, Lutterel, Simon, Pelham, Beard, McArdell, Houston, Miller, Spooner, Purcell, Frye, Green, Earlom, etc.

**Aquatints.**—In this process the surface of the plate is prepared with a "ground" of resin of finely granulated consistence. The drawing is done with the penetration of the etching needle exposing the plate to the acid. The beauty of the aquatint depends upon the various depths to which the acid bites into the metal. Certain parts are "stopped out" with the resisting substance (where only shallow lines are desired) early in the bath, the plate being again immersed for deeper lines, then other lines "stopped out," and the plate returned to the acid. This process is continued for perhaps a dozen bitings, each application creating another tone. When finished the work resembles an Indian ink drawing. Noted workers in this method were Le Prince, Malton, Stadler, Lewis, Sutherland, Turner (C.), Metz, Havell, Prout, F. Goya, Delacroix, etc.

**Bibliography.**—Hayden, A., 'Chats on Old Prints' (New York 1906); Hind, A. M., 'A Short History of Engraving and Etching' (Boston 1908); Maberly, J., 'The Print Collector' (New York 1880); Richter, E. H., 'Prints' (Boston 1914); Wedmore, F., 'Fine Prints' (New York 1897); Weitenkampf, F., 'Prints and Their Production: a List of Works in the New York Library' (New York 1916).

CLEMENT W. COUMBE,  
Technical Art Expert.

**ENGROSSING**, in law, an act which, on statute books, when the natural laws of trade were little understood, and political economy not even guessed at, was set down as a crime. It consisted in something similar to what nowadays is known as "cornering the market" by buying up the crops or the herds wholesale (Fr. *en gros*) before they were fit for use, in order to retail them at a great profit when they matured and were available for consumption. The offense was not only a statutory offense in England, but a crime in common law, and from the time of Edward VI to that of Queen Anne laws were repeatedly passed for its repression. Even in the last century a prosecution for engrossing was witnessed in an English law court. In 1844 all English, Irish and Scottish statutes, in respect to the offenses known as forestalling, engrossing and regrating, or retailing at a profit, were repealed. In more recent times there has been a good deal of litigation in the United States, and much discussion all over the civilized world with regard to the legality of corporations formed for the express purpose of monopolizing the trade in certain necessities or luxuries of life. (See COMBINATION; MONOPOLY; RESTRAINT OF TRADE; TRUSTS). Consult Cunningham, W., 'The Growth of English Industry and Commerce' (3 vols., Cambridge 1903–12); Girdler, J. S., 'Observations on the Pernicious Consequences of Forestalling, Regrating and Ingrossing, etc.' (London 1800); Illingworth, W., 'An Inquiry into the Laws, Ancient and Modern, Respecting Forestalling, Regrating and Ingrossing, etc.' (London 1800); Marwick, Sir J. D., 'On Forestalling, Regrating and Engrossing, etc.' (in Society of Antiquaries of Scotland, *Proceedings*, Session 1902–03, Vol. XXXVII, pp. 145–159, Edinburgh 1903).

The term is also used to denote the careful transcription of a deed, statute, or other legal document in large hand; and is often applied, in the United States, to the final and certified copy of a statute, which is ready to be signed by the President, or the governor of a State.

**ENHARMONIC** (from Gr. *εναρμονικός* in accord). In modern music a general term to denote a difference in degree but not in pitch, though specifically there is a slight variation of pitch, which the same note takes according to its adjustment to a fundamental *tonic*. Thus C ♯ and D ♭ are practically the same note on keyed instruments, yet strictly speaking, the former should be produced by 15–16 of the whole string sounded, the latter by 9–10. An enharmonic change of key, that is shifting from one scale to another, as in transposing C ♯ to D ♭, often enables a composer to write more easily by avoiding recurrent accidentals. In ancient Greek the enharmonic mode was distinguished by the use of small intervals or quarter tones, such as the tetrachord of which the first two steps were quarter steps and the third a major third. See *MODE*.

**ENHUBER**, ěnhoo'bĕr, Karl von, German painter: b. Hof, Bavaria, 16 Dec. 1811; d. Munich, 6 July 1867. He studied at Munich, at first being known as an animal painter and later applying himself to romantic and humorous themes, being especially felicitous in depicting the peasantry of Upper Bavaria. Among his works are 'The Dying Gunner'; 'Poachers'; 'Smoking Boy'; 'Interrupted Game of Cards';

'Munich Burgher Guardsman'; 'Grandfather's Delight'; 'Wood Carver in His Shop'; and 'Stage Coach at the Tavern.'

**ENID**, the wife of Geraint in Tennyson's 'Idylls of the King' (q.v.). She is upheld as a model of conjugal fidelity.

**ENID**, Okla., city and county-seat of Garfield County, 36½ miles north by east of Kingfisher and 88 miles by rail west by north of Oklahoma City, on the Chicago, Rock Island and Pacific, the Atchison, Topeka and Santa Fe, and the Saint Louis and San Francisco railroads. It is a banking city; owns its waterworks, and adopted in 1909 the commission form of government. It contains a College of Fine Arts, Saint Francis Institute, Phillips University, a business college, a State institution for the insane, an excellent high school, a Carnegie library, courthouse, two hospitals, Federal buildings, opera house, etc. Among the industrial establishments are tile and iron works, sash and door factory, electric supplies, nursery, marble works, washing machine factory, metal silo factory, planing and flour mills, bottling works, manufactories of binders, candy, bricks, corn-seeders, steel posts, boilers and rugs. The United States census of manufactures for 1914 showed within the city limits 45 industrial establishments of factory grade, employing 383 persons; 276 being wage-earners receiving annually a total of \$175,000 in wages. The capital invested aggregated \$1,667,000 and the year's output was valued at \$2,611,000: of this, \$563,000 was the value added by manufacture. There are two parks. Enid is situated in a rich agricultural section and is one of the largest poultry centres west of the Mississippi, shipping in 1913 more than \$3,000,000 worth of poultry and eggs. Underneath the city from 35 to 45 feet flows a subterranean river, with an inexhaustible supply of pure soft water, which is pumped to the reservoirs at a cost of less than six cents per 1,000 gallons. Pop. 20,000.

**ENIMÁGAN**, a linguistic stock of Indians in South America, inhabiting the northern half of the Gran Chaco. It includes the Angaité, Enimá, Guaná, Sanapana, Sapuki, Sújen, Toosle and other lesser tribes. Consult the works of Boggiani, Hawtrey, Kersten, Schuller and other anthropologists who have written on these tribes.

**ENKHUIZEN** ěnk'hoi-zĕn (Lat. *Enchusa*), Holland, town on a projection in the Zuyder Zee, 29 miles northeast of Amsterdam. Its most important public building is an elegant town house with a lofty tower, and mural decorations by Johan van Neck. In the 17th century it had a population of upward of 40,000 and sent a fleet of 400 vessels to the herring fisheries, but the herring trade has died away. Its chief industries now are ropemaking and shipbuilding. The town is the birthplace of the painter Paul Totter. Pop. 7,748.

**ENLIGHTENMENT**, Philosophy of, the name popularly given to much of the philosophical thought of the 18th century, which cut loose from superstition and attempted to establish reason as the foundation of all belief and of all rules of conduct. It included the empiricism and deism of the English school, the sensualism of the French as well as the ultra-nationalism of Germany. Individualism was a strong figure

in its teachings. Locke, Bayle and Leibnitz, Hume, Voltaire, Lessing, Tom Paine and Benjamin Franklin were the most representative of the school, if school it may be called. Consult Hibben, J. G., 'Philosophy of the Enlightenment' (New York 1910) and any standard work on the history of philosophy.

**ENLISTMENT**, a contract between a government and an individual, in accordance with which the latter voluntarily assumes the duties of a soldier in return for which the government assures him a soldier's rights, pay and allowances. It differs from ordinary contracts for services in that it involves a change of status, so that the contract cannot be broken with impunity at the will of the enlisted man. Enlistment is the method of obtaining soldiers to which those nations resort that do not favor conscription. Accordingly before the European War, it was best exemplified by the armies and navies of the English-speaking peoples. In the United States army, recruits to be enlisted must be of good moral character, i.e., must never have been convicted of a felony nor imprisoned — and must be able-bodied, and between the ages of 18 and 35, if it is their first enlistment. They must be citizens or have taken out their first papers, and must be able to speak, read and write the English language. The physical standards vary somewhat with the different branches of the army and the need for men, but in time of peace are very stringent. The enlistment of recruits is part of the duty of the adjutant-general's department. The period of enlistment is seven years, of which the first three or four, as the case may be, are spent with the colors, and the remainder with the Army Reserve, which is only on duty in time of war. Extra pay is allowed for re-enlistments within three months.

In the navy, candidates for enlistment must be of sound physique, not subject to fits, and able to read or write; or otherwise of satisfactory general intelligence. In general, only citizens of the United States and its possessions are accepted. They must be of good character and must not have been convicted of a crime. Enlistments in the grade of apprentice seamen are made among those between the ages of 17 and 25. The term of enlistment for those under 18 is until they become of age; for those over 18, four years. For those under 18, the consent of the parent or guardian is necessary. All those enlisted after they are of age serve for four years, but the term may be extended for from one to four years by the voluntary agreement of the enlisted man, if he is not undesirable. The upper limit of age for enlistment is 35, but not all ratings have the same limit. Enlistments are made at naval rendezvous, on board receiving ships, on board cruising ships which are short of their complement at a port where there is no rendezvous or receiving ship, on board vessels of the Bureau of Fisheries and at naval stations to fill up the complement of their yard craft. Finger-prints are taken at each enlistment. As in the army, extra pay is given to those who re-enlist, but the period within which this re-enlistment may take place is four months.

In the British army, since the law of 1907, the army consists of the regulars and the territorials. The regular army comprises the permanent army, the army reserve and the special

reserve. The period of enlistment is 12 years, of which three, five or nine years may be spent in the reserve. The maximum service permitted to good service men is 21 years, after which they are pensioned. On the average those men who serve in the colonies or in India serve from 12 to 16 years. Enlistment in the special reserve is for six years, in the territorial army for four.

In the active force of the British navy, the majority of the enlistments are made between the ages of 15 and 16½. After two years of preparation, the term of service with the fleet is 12 years. Re-enlistment for 10 years is permitted. See ARMY ORGANIZATION.

**ENNA, August**, Danish composer: b. Nakskov, Laaland, 1860. He was entirely self-taught. In 1880 he became violinist of a traveling troupe and in 1881 settled at Copenhagen, where he eked out a living as a violinist and produced the operetta, 'A Village Tale.' Later he was made conductor of a provincial company. During this time he produced several compositions which brought him to the notice of Gade. Through the latter's instrumentality Enna was enabled to spend one year in study (1888) in Germany. He produced 'The Witch' in 1892, an opera which at once brought him success and fame. Other works since then have been received more or less favorably but none has equaled his premier. These works include 'Cléopatra' (1894); 'Aucassin and Nicolette' (1896); 'Lamia' (1900); 'Ib and Little Christina' (1902); 'The Death of Antony' (1903); 'Golden Slipper of St. Cecilia' (1904); 'Gloria Arsena' (1913); 'A Mother's Love,' a legend for chorus and orchestra.

**ENNA, or HENNA**, Sicily, the ancient name of the town now known as Castrogiovanni. It is situated at about the centre of the island, was renowned in antiquity as one of the principal seats of the worship of Demeter. See CASTROGIOVANNI.

**ENNEACRUNOS** (Gr. 'nine springs'), a famous fountain at Athens (q.v.).

**ENNEKING, John Joseph**, American painter: b. Minster, Ohio, 4 Oct. 1841. He studied at Munich and Paris and was a pupil of Bonnat and of Daubigny. He paints chiefly landscapes and figure paintings. He received honorable mention at the Paris Exposition of 1900 and among his works are 'Moonlight on the Giudecca, Venice' (1876); 'Freshly Picked'; 'Drove of Cattle on a November Day' (1878); 'The Obersee'; 'Farmyard Scene in France'; 'November Twilight' (1881); 'Summer Twilight' (1883); 'Indian Summer' (1885); 'The Coming Storm'; 'Springtime'; and 'Autumn in New England' (Worcester Museum).

**ENNEMOSER, ěn'ě-mō-zěr**, Joseph, Austrian medico-philosophic writer: b. Rabenstein, Tyrol, 15 Nov. 1787; d. Egern, Bavaria, 19 Sept. 1854. He fought in the rising of the Tyrolese against the French in 1809, acting as secretary to its famous leader, Andreas Hofer. Previous to this he had begun the study of medicine at the University of Innsbruck and at the universities of Erlangen and Vienna. During 1813-14 he fought against Napoleon as an officer in the famous Luetzow Corps. After the Peace of Paris he went to Berlin, where he

finished his studies and in 1816 took his degree in medicine. In 1819 he became professor of medicine at the new University of Bonn. From 1837-41 he practised medicine in Innsbruck. In 1841 he went to Munich, where he obtained great reputation by the application of magnetism as a curative power. He had become interested in this subject while studying at Berlin and published a number of works relating to it. The most important of these is 'Geschichte des Thierischen Magnetismus' (Leipzig 1844), which has been translated by W. Howitt as 'The History of Magic' (2 vols., London 1854). Others of his writings are 'Historisch-Psychologische Untersuchungen über den Ursprung und das Wesen der menschlichen Seele' (Bonn 1824); 'Anthropologische Ansichten, oder Beiträge zur Besseren Kenntniss des Menschen' (Bonn 1828); 'Der Magnetismus im Verhältniss zur Natur und Religion' (Stuttgart 1842); 'Der Geist des Menschen in der Natur' (Stuttgart 1849); 'Anleitung zur Mesmerischen Praxis' (Stuttgart 1852); 'Das Horoskop in der Weltgeschichte' (Munich 1860).

**ENNERY, ěn-ně-rě, Adolphe Philippe D.**, frequently called **Dennery**, French dramatist: b. Paris, 17 June 1811; d. there, 25 Jan. 1899. He began life as a clerk, but later turned to the drama; he studied scenic effects, the quick change from the tragic to comic, and the contrast between the serious and ludicrous characters. He subsequently became the master of modern melodrama, producing alone and in collaboration some 200 plays. During the 50 years of his active life he accumulated a large fortune. In 1896 he was made a Commander of the Legion of Honor. His most successful plays include 'The Grace of God' (1841); 'Mary Jane' (1845); 'If I Were King' (1852); 'The Taking of Peking' (1861); 'Two Orphans' (1875); 'Martyrdom' (1887). He also wrote, in collaboration with others, the librettos for Gounod's 'Faust' (1856); Gounod's 'Le Tribut le Zamora' (1881); and Massenet's 'Le Cid' (1885). During the latter years of his life he also wrote a number of novels, most of them based on plays of his, which were published serially in Paris newspapers.

**ENNES, ěn'nās, Antonio**, Portuguese dramatist: b. Lisbon 1848; d. 1901. He was for some years prominent in journalism, and in 1886 was appointed chief librarian of the National Library and in 1890 Minister for Marine and the Colonies. His first play, 'The Lazarists,' had extraordinary success in Portugal and Brazil and long held the stage. It was followed by the comedy 'Eugenia Milton' (1874) and the dramas 'The Troubadours'; 'The Mountebank'; 'The Emigration'; 'A Divorce.' The last was translated into Italian and French.

**ENNIS**, Ireland, town in county Clare, on the Fergus, 25 miles northwest of Limerick by rail. It contains a Roman Catholic college and Ennis College, founded by Erasmus Smith. The ruins of a 13th century Franciscan abbey is one of its attractions and a notable monument has been raised to Daniel O'Connell. A considerable trade in grain, flour and agricultural produce is carried on and large fairs and markets are held. Pop. 5,472.

**ENNIS**, Tex., city of Ellis County, 35 miles south of Dallas, on the Houston and Texas Central and the Texas Midland railroads. It has extensive agricultural and stock-raising interests and contains cotton compresses, gins, railroad repair shops, cottonseed-oil mill and a flour mill, etc. Since 1914 it has been under the commission form of government. The waterworks are municipal property. Pop. 5,669.

**ENNISCORTHY**, Ireland, town, in the county of Wexford, situated on the river Slaney, 77 miles south of Dublin. There is an old castle erected by one of the early Norman conquerors, and in the neighborhood is Vinegar Hill, the scene of a skirmish in 1798, when the town was stormed by the rebels. The river Slaney is navigable and there is a considerable trade in provisions. Pop. 5,495.

**ENNISKILLEN**, Ireland, a borough and market town of county Fermanagh, 37 miles northeast of Sligo, on an island in the narrowest part of Lough Erne. Suburbs are on the adjoining mainland. In its town hall are kept the flags of the battle of the Boyne. The battle of 1689 between the forces of James II and William III, in which William's forces were victorious, took place here. The noted regiment called Enniskillen Dragoons was first formed from the defenders of the town at this battle. The manufacture of cutlery, straw hats, shirts and collars and the tanning of leather are carried on here, and there are several steam sawmills. Pop. 4,847.

**ENNIUS**, Quintus, Latin poet: b. Rudiae, near Brundisium, 239 B.C.; d. 169 B.C. When he was 38 Cato the Censor brought him to Rome, where he soon gained the friendship of the most distinguished men and instructed the young men of rank in Greek. With an extensive knowledge of the Greek language and literature he united a thorough acquaintance with the Oscan and Latin tongues and exerted great influence on the last. He wrote an epic poem in hexameters, 'Annales,' describing the history of Rome from the arrival of Æneas in Italy to the poet's own times; tragedies and comedies, satires, epigrams, precepts, etc., but nothing now remains except fragments given as quotations in other ancient authors, many of them mere citations by grammarians and other insignificant extracts. A few larger fragments have been preserved, which give a favorable impression of his genius. His success in his own day was great. His poems were for a long period read aloud to admiring multitudes, and they were often quoted and referred to by the great writers of antiquity. Fragments of his works have been edited by Müller, L. (Saint Petersburg 1885); Ribbeck, O., in 'Scæniæ Romanorum Poesis Fragmenta' (Leipzig 1897); and Vahlen, J., (Leipzig 1854 and 1903). Consult Duckett, E. S., 'Studies in Ennius' (in *Bryn Mawr College Monographs*, Monograph Series, Vol. XVIII, Bryn Mawr 1915); Knapp, C., 'Vahlen's Ennius' (in *American Journal of Philology*, Vol. XXXII, p. 1, Baltimore 1911); Müller, L., 'Der Dichter Ennius' (in *Sammungen Wissenschaftlicher Vortraege*, edited by R. Virchow, N. F. Ser. VIII, Heft 185, Hamburg 1893); 'Die Entstehung der Römischen Kunstdichtung' (ib. N. F. Ser. IV, Heft 92, Hamburg 1889); Postgate, J. P., 'Corpus Poetarum Latinorum' (Vol. VI, London 1894);

Ribbeck, O., 'Geschichte der Römischen Dichtung' (2 vols., Stuttgart 1887-89); Vahlen, J., 'Bemerkungen zum Ennius' (in Königl. Preuss. Akad. der Wiss., *Sitzungsberichte* 1899, p. 266, Berlin 1899); 'Über Ennius und Lucretius' (ib. 1896, Part I, p. 717, Berlin 1896); 'Über die Annalen des Ennius' (in Königl. Preuss. Akad. der Wiss. Philos.-Hist. Klasse, *Abhandlungen* 1886, Part I, Berlin 1886).

**ENNODIUS**, Magnus Felix, a Latin Church father: b. at either Arles or Milan about 473; d. Pavia, 17 July 521. He early became an orphan. When the Visigoths invaded Italy he was sent to an aunt in Milan who educated him. After her death he married a wealthy woman and lived in lavish fashion. A severe illness made such a deep impression upon him that he entered the priesthood and his wife became a nun. In 496 he went to Rome and soon became a noted man. He was the first to give the Bishop of Rome the name of Pope. In 511 he succeeded Maximus as Bishop of Pavia. Twice he was sent as a messenger to the Emperor Anastasius with the plan of reuniting the Eastern and Western Churches. His writings include a 'Life of Epiphanius' and several theological treatises. He is said to have written in favor of the freedom of the will. His writings have been published in Basel 1569, Tournay 1610, Paris 1611, and also in Migné's, 'Patrologiæ Latine' (Vol. LXIII).

**ENNS**, Æns, river in Austria, has its rise in the Alps of Salzburg, flows east-northeast and then takes a northwesterly course, discharging into the Danube near Mauthausen. Length about 160 miles. Through part of its course it forms the boundary line between Upper and Lower Austria.

**ENOCK**, Hebrew patriarch. He became the father of Methuselah at the age of 65 years; and we are told that he "walked with God" and at the age of 365 years "God took him". The words quoted are generally understood to mean that Enoch did not die a natural death, but was removed as Elijah was. The book of Hebrews (xi, 5) confirms this view. Enoch is the name of three other persons in the Bible, one of them being the eldest son of Cain (Gen. iv, 17). Saint Enoch, associated with the city of Glasgow, is a corruption of Saint Thenaw, the name given by Saint Serf to Saint Kentigern's mother.

**ENOCK**, Books of. According to Gen. v 21-23, Enoch lived 365 years, and he walked with God and disappeared, for God took him. He is supposed to be identical with the seventh of the 10 antediluvian kings in Berosus (Eue-dorachus), the Enmeduranki of K 2486, 4364, the seventh king in the Sumerian list discovered by Pœbel (Babylonian Publications of the University of Pennsylvania, VI, Philadelphia 1913). Enmeduranki, like Enoch, was called into communion with the gods and initiated into the mysteries of heaven and earth. If the number 365 indicates the original solar character of Enoch, the story is likely to have been derived from a Babylonian or Amorite version in which the regnal years had not been brought into the chronological system found in Berosus. The opportunities of this world-wanderer for observing celestial phenomena, reading the heavenly tablets and foreseeing the future naturally invited speculation. He became the inventor

of writing, mathematics and astronomy, and the forerunner of Dante as an explorer of heaven and hell. Alexander Polyhistor in the time of Sulla found him referred to by a writer as having learned astronomy from the angels (Eusebius, *Præparatio evangelica* ix, 17, 8). With the growth of angelology the interest centred on the fate of the "sons of God" who had married the "daughters of men" (Gen. vi, 1ff.), while the concern about the future of sinners and saints on earth and in the other world demanded authoritative revelations. None was better fitted to impart information on these things than the translated patriarch.

The writings ascribed to Enoch do not seem to have been generally accepted as canonical at any time, either by Jews or Christians. In some circles, however, they have been regarded as authentic and cherished as sacred books. From references in the book of Jubilees and the earlier stratum of the Testaments of the Twelve Patriarchs it may perhaps be inferred that some of them belonged to the 70 hagiographa, mentioned in 4 Ezra xiv, 46, which were not included in the finally adopted Palestinian canon. There is one direct quotation in the New Testament: The epistle of Jude (vs. 14) cites a passage from one of the books of Enoch in such a manner as to show that it was considered a genuine utterance of the patriarch and an inspired prophecy. In the epistle of Barnabas another passage is quoted as "Scripture." Tertullian defended the authenticity and sacred character of the book known to him and maintained that the Jews rejected it because it referred prophetically to the Lord, having probably in mind the passage cited by Jude. Clement of Alexandria also quotes the book with confidence. Origen charges Celsus with not having read the book of Enoch whence his statement concerning the angels was taken, and not being aware that the books ascribed to Enoch were not universally accepted as divine in the churches. Anatolius of Laodicea quoted a passage simply to show the character of the Jewish calendar, but Zosimus of Panopolis refers to the books as "ancient and divine scriptures." Jerome rejected the book of Enoch as apocryphal; Augustine took the same position; and it is counted among the Apocrypha by the Apostolic Constitutions (5th century), Pseudo Athanasius, Nicephorus' *Stichometria* (1500 or 4800 stichi), and the *Index LX librorum*. The parts copied by George Syncellus (c. 790) may have been drawn from Pandorus of Alexandria; but the manuscript found at Panopolis seems to have been written later than the 8th century. Many writers, from 4 Ezra and 2 Peter to George Cedrenus in the 11th century, who do not mention the name of Enoch show an acquaintance either with the book itself or with its characteristic ideas, notably that of the fall and punishment of the angels.

In Abyssinia the book of Enoch has maintained its position in the canon before the book of Job to the present time, not only among the Christians, but also, according to the testimony of Bruce, among the Jews whose Ethiopic text, however, has not yet been examined. To what extent another book ascribed to Enoch, preserved in the Slavonic Church, was regarded as canonical cannot be determined. The Hebrew Enoch, though quoted by many mediæval Jewish writers, does not seem to have been con-

sidered by them as a part of the canon. Venerable Bede (died 735) thought that the book of Enoch merited to be counted among the sacred scriptures because of its authority, age and use, but especially because of the testimony of Jude. William Whiston defended the canonicity of the book known to him through Syncellus, and William Murray regarded the nucleus of the Ethiopic Enoch as genuine and inspired. The Roman Catholic Church reckons the books ascribed to Enoch among the Apocrypha of the Old Testament, while many Protestant scholars, who give this name to the deuterocanonical books of the Old Testament, designate them as Pseudepigrapha, a term first used by Jerome in regard to the Wisdom of Solomon and the Epistle of Jeremiah. Unidentified quotations indicate that all the Enoch literature has not yet been discovered. The three extant works are generally called the Ethiopic, Slavonic and Hebrew Enoch, because of the languages in which they first became known, in their full extent, to modern scholars.

**Ethiopic Enoch.**—Whether Pico della Mirandola possessed a manuscript of this book is still uncertain. According to Fabricius, it was stated by many, on the testimony of Reuchlin, that he had purchased a copy of it for a large sum of money. In Reuchlin's treatise, *De arte cabalistica* (1517), Simon does not question the possible survival of some such books as that of Enoch, but declares that he cannot afford, like Mirandola, to buy at great expense the 70 books of Ezra. Mirandola himself speaks of his purchase and indefatigable study of these books, both in his *Apologia*, written in 1489, p. 178, and in *De hominis dignitate*, p. 330. A description of his cabalistic codices was given by Gaffarel in 1651 (reprinted in Wolf, *Bibliotheca hebraica*, I, 1715); in the first manuscript, ascribed to Recanati (13th century), there are some extracts from the Hebrew Enoch. This may have given rise to the rumor. But Reuchlin refers directly to the book of Enoch in *De verbo mirifico*, written in 1494 (Lyon 1552, pp. 92f). Here Sidonius lashes the gallows-birds who place splendid titles in front of the volumes they offer, falsely declaring that one is the book of Enoch, another the book of Solomon. It would seem, therefore, that Reuchlin had heard of a separate book of Enoch being offered for sale. Since Ethiopic texts were published as "Chaldæan" by Potken already in 1513 and Reuchlin knew in 1515 that Benignus had studied the "Chaldic" letters used by Prester John, it is not altogether improbable that the book to which he referred 20 years earlier was the Ethiopic Enoch and that such a work may have drifted into Mirandola's library; but it may have been a Hebrew Enoch. There can be no question that Guillaume Postel before 1553 was shown a copy of the Ethiopic Enoch at Rome by an Abyssinian priest and had its contents explained to him, as he refers to the Noachic interpolations. Gilles de Loches, a Capuchin missionary, who spent seven years in Egypt, reported to Peiresc that he had seen (c. 1630) this book in Ethiopic script and language, and gave the title correctly. Gassendi relates that Peiresc purchased another manuscript. This was afterward found by Ludolf not to be the book of Enoch and it has not been published yet, though it contains the story of Enoch's birth. James Bruce se-

cured a copy of Ethiopic Enoch in Abyssinia in 1769 and brought to Europe three manuscripts. A brief account appeared in Michaelis 'Orientalische und Exegetische Bibliothek' (1774); a fuller account was given by Bruce himself in 1790. The text has been edited by Laurence (1838) on the basis of one manuscript; by Dillmann (1851) who had five manuscripts; by Flemming (1902) who used 15; and by Charles (1906) who had at his disposal 23. Charles consulted 29 in his translation of 1912. None of these is earlier than the 16th century; even the oldest of them inspire no very great confidence, and all have manifestly suffered much in transmission. Of the Greek text the fragments preserved in Syncellus, viz., vi-x, 14; xv, 8-xvi, 1, and viii, 4-ix, 4 in duplicate, were first published by Scaliger (1609), then by Goar in the *editio princeps* of the *Chronographia* (1652), by Fabricius (1713), Dindorf (1829) and recent editors of Enoch. A fragment, containing lxxxix, 42-49, was published by Mai (1844) and Gildemeister (1855). A larger part, including i-xxxii, 6 and xix, 3-xxi, 9 in duplicate, was discovered at Panopolis (modern Akhmim) in 1886-87 and published by Bouriart (1892-93), Lods (1892) with a French translation, Dillmann (1892), Charles (1893) and Radermacher (1901). A fragment of a Latin translation, cvi, 1-18, was published by Charles (1893) and James (1893).

Already Grotius, familiar only with the Syncellus fragments, expressed the opinion that the book of Enoch originally was small, but grew gradually by expansion. Laurence (1821) pointed out some of the more obvious Noachic sections, and de Sacy (1822) suspected Christian interpolations. Murray (1836), who contended for a genuine nucleus, recognized among the extensive later additions several distinct books and assigned a separate authorship to lxxii-lxxxii. Bruno Bauer (1841) maintained that there were several authors and especially that xxxvii-lxxi formed a book inserted in the larger volume. Dillmann (1853) assumed a different authorship for cvi-cvii and cviii and a number of interpolations. Sieffert (1867) argued a distinct origin for lxxxiii-xc. Through the studies of Krieger (1845), Ewald (1854) and Hilgenfeld (1857) the marked difference between xxxvii-lxxi and the rest of the work became generally recognized; and through the analytic work of O. Holtzmann (1888) and Charles (1893) wide currency was given to the view that the volume is made up of five distinct books by different authors, viz., 1, i-xxxvi; 2, xxxvii-lxxi; 3, lxxii-lxxxii; 4, lxxxiii-xc; 5, xci-cv, and two shorter appendices, cvi-cvii and cviii. This division is indeed largely suggested by sub-headings in the text itself. But within each of these books a lack of unity has also been felt by critics and it has been explained either by accretion or by compilation. It is thought that an original work has been expanded in the course of transmission, or a compiler is supposed to have pieced it together from various sources. The earlier and more widely accepted theory is that of accretion, but in recent years several scholars have favored a documentary theory similar to that now in vogue in Pentateuchal criticism. It is therefore proper to consider the composition as well as the date and original language of each book separately.

Book I unquestionably contains some separate elements. It is likely to have begun originally in vi, 1, since i-v seems to be a general introduction to a larger volume which, however, did not as yet include xxxvii-lxxi. While xvii-xix and some other passages appear to be interpolations, the attempt to explain the seemingly identical rôles of Semyaza and Azazel by the compilation of two documents is less convincing. The idea of a Greek original has no defender to-day in the case of this or any other part of Ethiopic Enoch. Those who have made a special study of the subject are substantially agreed that Book I was written in Aramaic from which it was translated into Greek. As the descriptions of the fall of the angels, Enoch's mediation and his celestial journey give no clear indications of date; the relation to Book IV, which evidently is somewhat younger, must decide. Some scholars have thought of the period preceding the Maccabean uprising, the majority, on what would seem more adequate grounds, of the reign of John Hyrcanus (135-104 b.c.).

In Book II the outlines of a ground-plan are clearly discernible; inserted excerpts from a book of Noah are equally unmistakable in liv, 7-lv, 2; 1; and lxx-lxix, 25. That the remainder is not a Joseph's coat without seams, as it was once called, is now universally admitted. But while some recent critics, like Appel and Gry, assume a compilation of different documents, one designating the celestial guide as "the angel who went with me," another as "the angel of peace," and a third being particularly interested in wisdom, most scholars have resorted to the theory of more or less extensive interpolations. Some have been satisfied with indicating as such xli, 3-8; xlili; xlv; lix; lx; lxx; lxxi. Others, like Bruno Bauer, Böttcher, Drummond, Pfeiderer, De Faye and Bousset, have looked upon all the passages referring to the Messiah as Christian interpolations. In the case of these Schmidt thinks of successive expansions, first by Jewish, and then by Christian hands. The idea of a Christian origin of the Parables, held by Hilgenfeld, Vernes, Kuene, Tideman, Stanton, König and Cornill, is no longer advocated. As to the original language there is still a decided difference of opinion between the two scholars who have published the results of special investigation upon this point; Charles thinks that it was Hebrew, Schmidt that it was Aramaic. The former assumes that the Ethiopic was made from a Greek version, in which the New Testament term for the "Son of Man" was uniformly used, by an Aramaic-speaking Jew who rendered it in three different ways, corresponding to three Aramaic expressions. The latter thinks that the absence of even the slightest sign of acquaintance with this particular book in patristic literature throws doubt upon the existence of a Greek version, and in any case deems it probable that the translation was made by an Aramaic-speaking Jewish Christian who used two other terms besides the one uniformly employed in the New Testament, because he found three expressions for "Son of man" in the Aramaic original before him. In regard to the date, the most widely accepted view at the present time is that this book was written not long before 63 b.c. "The kings and the mighty," who are often mentioned as persecutors, are



supposed to be Alexander Jannæus and the Sadducees. It is difficult, however, to see how they could be charged with putting their "faith in the gods they have made with their own hands" (xlvii, 7); and many scholars have considered it more natural to understand the phrase as referring to pagan rulers. If Roman emperors and governors are meant, the time of Gaius Caligula (37-41 A.D.) is more likely than that of Herod the Great. A Jewish expansion in the time of Domitian is not improbable; and it is significant that those ideas and expressions which have their closest counterparts in the Gospels and present the Messiah in a more transcendent character than is found anywhere in Jewish literature, fit very loosely in the context and are connected with a title which even in the Gospels appears to be a translation, not of a Greek, but of a Christian Aramaic original.

Book III, dealing with astronomy, has no doubt a few interpolations. The endeavor to prove that it is a compilation of four documents dovetailed into one another does not seem to be called for by the facts. If Jubilees was written in Hebrew, as is probable, this book may have been written in the same language. Like Jubilees and Slavonic Enoch, it advocates a solar year of 364 days; it is quoted in the former work (iv, 17, 21) and may be dated c. 110 B.C. The author makes the longest day of the year 16 hours, which led Laurence and Murray to infer that his home was near the Caspian or the Black Sea; and Martin thinks that it may indicate the use of a document written in the latitude of Constantinople. It is possible that the writer reflected upon the length of the day in the region where he supposed the antediluvians to have lived. In Book IV there are some obvious additions. The original language is supposed to be Aramaic. In the historic vision the 70 shepherds are no longer conceived of as either native or foreign rulers, but as angels; yet it is admitted that the four periods of their domination represent the Chaldean, Persian, Ptolemaic and Seleucid kingdoms, and the great horn in xc, 9, is assumed to refer either to Judas Maccabæus or John Hyrcanus. The latter is more probable, and the date is likely to be c. 108 B.C. Dislocations and interpolations are also found in Book V. It may have been written in Hebrew in the 1st century B.C. Not much later the two appendices seem to have been penned in the same language. The first of them has been assigned by some scholars to the Noachic stratum; others have surmised for it an independent Essene origin. Recent critics have been inclined to ascribe to the 2d century B.C. the book of Noah, from which excerpts have been copied in the book of Enoch; this is doubtful, and some of the appropriated passages may have been interpolations in the Noah apocalypse.

The influence of Babylonian, Persian and Greek speculation, mythical and scientific, upon this literature is unmistakable, though it has occasionally been exaggerated. It reveals the growing conceptions of angels and demons, heaven and hell, the Messiah and his kingdom, the last judgment and the resurrection, in the generations immediately preceding the appearance of Jesus. If the original of the Parables could be found, or the later accretions removed with a high degree of certainty, the actual approach to the Christology of the New Testa-

ment might be determined with greater assurance than now is possible. The eschatological notions seem to have been in a fluctuating state. There is nowhere a clear allusion to a resurrection of the body; immediately after death spirits pass to their destiny of joy or suffering and appear to be clothed with a spiritual body; yet a final judgment is emphasized, and at least in Book I a return to terrestrial life seems to be contemplated. The work as a whole presents numerous problems that cannot be solved until the Semitic original is recovered.

**Slavonic Enoch.**—This book was first published by A. Popov in 1880 from a manuscript written in 1679 in a South Russian dialect under the title 'The Book of the Secrets of Enoch.' In 1886 Sokolov found at Belgrade a Bulgarian manuscript of the 16th century representing the same recension. Novaković published in 1884 a Serbian manuscript of the 16th century. found at Belgrade, representing a different recension. Of the same type are a manuscript in Vienna of the 16th century, one of the 17th owned by Barsov in Moscow, and a number of fragments, some as old as the 14th century, published by Tichonravov, Pypin, and Popov. It has become customary to designate the former recension, which is longer, as A, the latter as B. Of A an English translation was made by Morfill (1896); Bonwetsch gave a German version of both A and B (1896); excerpts of A were rendered into Latin by Székely (1913); and both A and B were translated into English by Forbes (1913). Charles, Bonwetsch, Harnack, Schürer and Székely have looked upon A as a faithful translation of the Greek text and B as an abbreviated copy of the Slavonic translation, and have therefore concluded that the author was an Alexandrian Jew writing his work in Greek. Charles indeed maintains that some parts may originally have been written in Hebrew, since he thinks they are quoted in the Testaments of the Twelve Patriarchs, but deems it impossible to separate them from their context. Unfortunately, none of the nine passages in that work in which Enoch is quoted can be regarded as having come from this book, as Schürer has shown. But Schmidt has pointed out that practically every passage cited to prove either familiarity with the Greek version of the Bible or acquaintance with Hellenistic thought is absent in B. He does not consider it possible that a Christian Slav, living in the 10th or 11th century, could have possessed such a marvelous knowledge of the tendencies of thought among the Alexandrian Jews, or could have had any motive for exercising his skill in the removal of every touch of Greek influence. But if A represents an Alexandrian expansion of a Greek text still free from the peculiarities indicating a local origin, the latter may well be a translation of a Hebrew or Aramaic book written in Palestine at some time between 50 B.C. and 70 A.D. Other books of Palestinian origin are equally silent concerning the Messiah and a physical resurrection. The interest in a solar year of 364 days (xvi, 5 B) may point to a period not very long after Eth. Enoch lxxii-lxxxii and Jubilees; the later Greek recension A has a year of 365¼ days (xiv, 1; xvi, 5). A few Christian interpolations have been suggested, especially by Schürer and Székely. Those worthy of consideration, such as the statement concern-

ing the pre-eminence of the eighth, i.e., the first day (xxxiii, 1, 2), the prohibition of oaths in very nearly the words of Jesus (xlix, 1, 2) and the condemnation of sacrifices (xlv, 3), are found in the longer recension. The counsel not to requite evil (l, 4) need not be Christian. But in the ethics of the original work there is an unmistakable approach to the teachings of Jesus. Origen knew this work as a part of his Greek book of Enoch, and refers to the descriptions in xxiv, 2, and xlvii, 3. It reveals no acquaintance with Eth. Enoch xxxvii-lxxi.

**Hebrew Enoch.**—During the Middle Ages a book of Enoch written in Hebrew was quoted by many Jewish writers. It may have been of this work that Pico della Mirandola and Reuchlin had a vague knowledge through excerpts or some longer manuscript. Drusius called attention to two quotations in the book of Zohar (13th century). A list of quotations in Menahem Recanati, Hekaloth, Maase Bereshith, Pirke de Rabbi Eliezer, and Rasiel has been given by Jellinek. This scholar published in 1873 from a Munich codex the 'Sefer Hekaloth or Book of Enoch.' It was an incomplete edition, but could be supplemented by the 'Sefer Hekaloth of R. Ishmael,' published at Lemberg, in 1864. An unedited manuscript is in the Bodleian Library at Oxford. A critical edition and a translation are needed. Brief descriptions have been given by Buttenwieser and Charles. The book tells of the ascent of Rabbi Ishmael to heaven where he receives a series of revelations from the angel Metatron (Lat. metator = guide), with whom Enoch has been identified. Various parts of Ethiopic and Slavonic Enoch are used by the author, though there is no trace of the characteristic ideas of the Parables. An apocalyptic fragment, preserved in the 'Siddur' of R. Amram Gaon (9th century), and apparently written at the time of the Hadrianic persecution, seems to furnish a link connecting Slavonic Enoch with Hebrew Enoch, which is likely to be earlier than the 4th century, as it is quoted in Babylonian Talmud, Berakoth 7a. What the language of any earlier Enoch book may have been cannot be inferred from this work; for when Aramaic ceased to be the vernacular many books were translated into Hebrew, among them even the Aramaic parts of Daniel.

**Bibliography.**—I. Translations, with commentary, in Latin, by Silvestre de Sacy, in *Magasin encyclopédique* (Paris 1800, Chaps. i-xvi, xxii, xxxi); Gfrörer, A. F., in 'Prophetæ Veteres Pseudepigraphi' (Stuttgart 1840); and Stephan Székely, in 'Bibliotheca Apocrypha' (Freiburg 1913, extensive excerpts); in English, by Richard Laurence (Oxford 1821; later editions 1833, 1838, 1883); Schodde, G. H. (Andover 1882); Charles, R. H. (Oxford 1893; 2d ed., 1912); in German, by Hoffmann, A. G. (Jena 1833-38); Clemens, Richard (Stuttgart 1850); Dillmann, A. (Leipzig 1853); Beer, G. (Tübingen 1900); Flemming, J., and Radermacher, L. (Leipzig 1901); in French, by Brunet, G., in Migne 'Dictionnaire des Apocryphes' (Paris 1856); Lods, A., of the Greek text (ib. 1892); and Martin, François (ib. 1906); in Russian, by Smirnov, A. (Kasan 1888); and in Hebrew, by Goldschmidt, L. (Berlin 1892). Introductions by Zöckler (1891); König (1893); Cornely (1894); Cornill (1896); Strack (1898); Bertholet (1906); Steuernagel (1912); Sellin

(1914); Mirandola, Pico della, 'Opera Omnia' (Basel 1572); Reuchlin, J., 'De arte cabalistica' (Hagenau 1517; appended to Galatin, 'De arcanis catholicæ veritatis,' Ortona 1518, and to Mirandola, op. cit.); Postel, G., 'De originibus' (Basel 1553); Scaliger, 'Thesaurus temporum' (Geneva 1609); Drusius, J., 'De patriarcha Henoch' (Frankfort 1615); Gassendi, P., 'De vita Peirescii' (Paris 1641); Ludolf, J., 'Historia æthiopia' (Frankfort 1681); Fabricius, J. A., 'Codex pseudepigraphus Veteris Testamenti' (Hamburg 1713); Calmet, A., 'Dissertation sur le livre d'Hénoch' (Paris 1720); Whiston, W., 'A Collection of Authentick Records' (London 1727); Bruce, J., 'Travels to Discover the Source of the Nile' (London 1790); Sacy, S. de, in *Journal des Savans* (Paris 1822); Murray, E., 'Enoch Restitutus' (London 1836); Bauer, Bruno, 'Kritik der evangelischen Geschichte' (Leipzig 1841); Krieger, E., 'Beiträge zur Kritik' (Nürnberg 1845); Lücke, F., 'Einleitung in die Offenbarung Johannes' (2d ed., Bonn 1852); Ewald, H., 'Abhandlung über des äthiopischen Buches Henoch Entstehung' (Göttingen 1855); Hilgenfeld, A., 'Die jüdische Apokalyptik' (Jena 1857); Sieffert, F., 'De apocryphi libri Henochi origine et argumento' (Königsberg 1867); Philippi, F., 'Das Buch Henoch' (Stuttgart 1868); Halevy, J., in *Journal Asiatique* (Paris 1867); Vernes, M., 'Histoire des idées messianiques' (Paris 1874); Tideman, A. in *Theologisch Tijdschrift* (Leiden 1875); Drummond, J., 'The Jewish Messiah' (London 1877); Deane, W. J., 'The Pseudepigrapha' (London 1891); Bousset, W., 'Die Religion des Judentums' (Berlin 1903); Appel, H., 'Die Komposition des äthiopischen Henochbuches' (Gütersloh 1906); Burkitt, J. C., in *Journal for Theological Studies* (Cambridge 1907); Schmidt, N., 'The Original Language of the Parables of Enoch' (Chicago 1908); Gry, L., in *Le Muséon* (Louvain 1908-10); Lagrange, J., 'Le messianisme' (Paris 1909); Schürer, E., 'Geschichte des jüdischen Volkes' (4th ed., Leipzig 1909); Charles, R. H., in 'Old Testament Apocrypha and Pseudepigrapha' (Oxford 1913). II. Morfill, W. R., and Charles, R. H., 'The Book of the Secrets of Enoch' (Oxford 1896); Bonwetsch, N., 'Das slavische Henochbuch' (Berlin 1896); Schürer, 'Geschichte des jüdischen Volkes' (Leipzig 1909); Forbes, N., and Charles, R. H., in 'Old Testament Apocrypha and Pseudepigrapha' (Oxford 1913); Székely, S., in 'Bibliotheca Apocrypha' (Freiburg 1913); Schmidt, N., 'The Two Recensions of Slavonic Enoch' (in *Journal of American Oriental Society*, New Haven 1918). III. Jellinek, A., 'Beth ha Midrasch' (Vienna 1853-78); Buttenwieser, M., 'Apocalyptic Literature' (in 'Jewish Encyclopedia,' New York 1901); Charles, R. H., 'The Book of Enoch' (Oxford 1912).

NATHANIEL SCHMIDT,

Professor of Semitic Languages and Literature,  
Cornell University.

**ENOCH ARDEN.** Tennyson's 'Enoch Arden,' a narrative in 911 lines of blank verse, is one of the most popular poems of modern times. Sixty thousand copies of it were sold soon after its publication in 1864 and translations appeared in seven foreign languages. The story itself was such as to make

a wide appeal, but the poet enhanced its power. He describes the life and scenery of an English fishing village and a sailor's exile on a tropic island with elaborate, vivid detail and genuine feeling. He shows also the strength and purity in humble English folk, as he imagines them; of certain simple, universal, if restricted, ideals of family life as seen in his hero's aspirations for his children and in his self-sacrifice when, returning from long absence to find that he has been thought lost at sea and his wife happily remarried, he refrains from disclosing himself. The story, as distinct from the setting, is presented with studied, almost prim, simplicity, but with narrative effectiveness, to be seen, for instance, in Enoch's silent, self-effacement after beholding Annie at the hearth with Philip and her children. False sentiment appears, perhaps, in Enoch's making sure that his wife shall know of his return after his death and in the author's emphasis upon the costliness of his hero's funeral. There is weight too in Bagehot's criticism that the poem is an example of ornate rather than pure art, concealing lack of truth to facts under beautiful but irrelevant details. Nevertheless, 'Enoch Arden' holds its place as one of the loveliest descriptive and idyllic poems in English.

WILLIAM HALLER.

**ENOCK, C. Reginald**, English mining expert and author: b. 23 Nov. 1868. He has spent many years in various countries in professional work and in the investigation of natural resources, especially in North and South America, and of the British empire. He has carried out scientific work for the governments of Peru and Mexico; has given papers and lectures before the Royal Geographical Society, the Royal Society of Arts, etc. He has taken an active interest in the work of economic reform. His publications include 'The Andes and the Amazon' (4th ed., 1910); 'Mexico'; 'An Imperial Commonwealth'; 'Life and Travel in the United States' (1910); 'Pioneering and Map-making'; 'The Republics of Central and South America' (1913); 'Human Geography and Industry Planning'; 'The Tropics, their Resources, People and Future'; 'The Need for a Constructive World Culture.'

**ENOMOTO, Buio**, boo'ō, Japanese statesman: b. Tokio 1839; d. 1909. He was educated in Europe, and returning to Japan in 1867 became the first president of a republic which he established in the island of Yego, but was ousted by the Japanese army in 1869. After imprisonment for two years he was appointed vice-admiral in the Japanese navy 1874. He served as Minister Plenipotentiary to Russia and became a member of the Council of State and Minister of Education 1888, Minister of Foreign Affairs 1891 and Minister of Agriculture and Commerce 1892, which office he held for four years.

**ENOS, ā'nōs**, Turkey, town on the north coast of the Ægean, 70 miles south by west of Adrianople. Its harbor is commodious, but much neglected and too shallow for deep-sea vessels. The trade, formerly of importance, has greatly decreased, Enos having been superseded as an export centre by the adjacent seaport of Dedeagatch. The town is the see of a Greek archbishop. Homer attests its antiquity

by alluding to it the 'Iliad' (IV, 519). Pop. 7,000, principally Greeks.

**ENRIQUEZ GOMEZ, ěn-rĕ'kĕth gō'mĕth, Antonio** (properly ENRIQUEZ DE PAZ), Spanish poet; son of a converted baptized Portuguese Jew: b. Segovia early in the 17th century. He entered the army in his 20th year and rose to the rank of captain; but in 1636 fled to Amsterdam, and, having there professed the Jewish faith, was in 1660 burned in effigy at a Seville auto-da-fé. The date of his death is not known. Besides 22 comedies, some of which passed as Calderon's (q.v.), he wrote a number of other works, both in prose and verse: 'La Vida de Don Gregorio Guadaña' (1644); 'La Culpa de Primer Peregrino' (Rouen 1644); 'El Siglo Pitagórico' (Rouen 1647); 'El Samson Nazareno' (Rouen 1647); 'Las Academias Morales de las Musas' (Madrid 1660). The first of these, his lyric poems, and two of his dramas have been republished in 'Biblioteca de Autores Españoles' (Vols. XXXIII, XLII, XLVII, Madrid 1846-80). Consult Fitzmaurice-Kelly, J., 'A History of Spanish Literature' (London 1898); Ticknor, G., 'History of Spanish Literature' (3 vols., Boston 1872).

**ENROLMENT**, an entry on a public register. In England this term denotes the registration of recognizances, deeds of sale, etc., on the rolls of chancery or of the ordinary courts, or by a clerk of the peace on the records of a court of Quarter Sessions. The term in this sense dates from the enactment in 1536 of the Statute of Enrolments, designed to prevent the practice of secret conveyances and requiring as a condition of their validity that they be enrolled or recorded, within six months of their date, in the manner prescribed by the act. See CONVEYANCE; REGISTRATION OF PROPERTY TITLES.

**ENS.** See ENNS.

**ENSCHEDÉ, en-skā-dā', Johannes**, Dutch printer: b. Haarlem 1708; d. 1780. He received his education at Leyden and in due time became head of the printing firm which his father had established. He introduced the type known as Holland Gothic and did much to further the art of printing. In 1768 his firm issued the 'Proef van Lettern,' specimens of printing types. His firm is still in business in Haarlem.

**ENSCHEDÉ**, Holland, town in the province of Overyssel, 30 miles east-northeast of Zutphen. Rebuilt since its destruction by fire in 1862, it has large yarn- and cotton-mills, iron products, print goods and electrical machinery. Pop. 35,448.

**ENSEMBLE**, all the parts of a thing taken as a whole, or the general effect produced by them. Thus the word is used to designate the general effect of a drama, opera or picture.

**ENSENADA, ěn-sā-nā'dā** (Spanish, a creek, cove or bay). (1) Seaport of Argentina, in the province of Buenos Aires. It is the port of La Plata and is about 40 miles southeast of Buenos Aires. (2) Seaport of Mexico, in the northern part of Lower California, on the Pacific coast, at the head of the Bay of Todos los Santos, about 50 miles south of the border and 70 miles southeast of San Diego, Cal. It has some few local manufactories and is the seat of a United States Consul. Pop. 2,170.

**ENSIGN, Orville Hiram**, American electrical and mechanical engineer: b. Ithaca, N. Y., 8 July 1863. He was educated at Cornell University. From 1882 to 1890 he served as machinist at Ithaca, Schenectady and New York, after which he was engaged as consulting engineer to several public service companies in Los Angeles and vicinity. In 1897 he became superintendent and chief engineer of the Southern California Power Company, and in this capacity planned and constructed the first successful 30,000-volt long-distance transmission in the world, and when this company was merged with the Edison Electric Company he became superintendent and chief electrical and mechanical engineer until 1904, when he was appointed chief electrical and mechanical engineer of the United States Reclamation Service and of the Los Angeles Aqueduct.

**ENSIGN**, the flag or colors of a regiment, in England, consisting of a field of white, blue or red, with the union in the upper corner, near the staff. Of naval ensigns the white flag is confined to the royal navy, the red to the merchant service, the blue to the naval reserves. In the American navy the ensign is the national flag, and it is also flown by the merchant service. In England, up to 1871, the lowest grade of commissioned officers in a regiment of infantry, by the senior of whom the regimental ensigns or colors were carried. The corresponding rank in a cavalry regiment was cornet. The name is now abolished, the title of 2d lieutenant being substituted for it. Also the title of the lowest grade of commissioned officers in the United States navy, which they receive on graduation from the Naval College. In the 16th century ensign was corrupted into ancient and is so used in Shakespeare, and was at that time applied in the two senses of a flag and the bearer of a flag. See FLAG.

**ENSIGN STAL'S TALES** (Fänrik Ståls Sägner). The best known work of Johan Ludvig Runeberg, the greatest Swedish poet of Finland; appeared in two parts, the first in 1848 and the second in 1860. Most of the poems are narratives and relate incidents from the war of 1808-09, when the Finns tried in vain to stem the Russian invasion. The poems celebrate the heroes of this struggle and present scenes of great dramatic power. The first poem, entitled 'Vårt land' (Our Country), is highly lyrical and has become the national hymn of Finland. The tales form a connected whole, even if the person of the ensign often steps behind the scenes. Although arranged rather loosely and without strict chronology they all refer to the war, and they all have the same general theme. This theme is love of country. Runeberg was inspired with a profound love for his native land and for its history, and was charmed by its natural beauty. In his poems he lauds the patriotism, the self-sacrifice and devotion of the men and women who suffered and died for Finland. 'Ensign Stål's Tales' are imbued with sound humor. While the background throughout is the deeply tragic struggle in a hopeless cause, humorous touches, artistically interwoven, relieve the strain. Consult Estlander, C. G., 'Runeberg's Skaldskap'; Wrangel, Ewert, 'Om Fänrik Stål's sägner'; Lagus, Ernst, 'Förklaringar till Fänrik Stål's sägner.'

J. ALEXIS.

**ENSILAGE**, ɛn'si-lāj. See SILAGE.

**ENSTATITE**, Mg Si O<sub>4</sub>, a silicate, chiefly of magnesium, but also containing more or less iron and aluminum. The mineral commonly occurs in massive or fibrous forms, but distinct crystals, prismatic in habit and belonging to the orthorhombic system, are also occasionally found. Its color varies; it may be white, greenish or brown. Its hardness is 5.5, and its specific gravity about 3.2. Enstatite is a common constituent of peridotites, crystalline schists and meteorites, and is also associated with certain serpentines. It belongs in the pyroxene group, is insoluble in hydrochloric acid and before the blow-pipe it fuses only along its thin edges. The name (Greek, "adversary") refers to these refractory qualities. It is found in Putnam County, N. Y., Bavaria, the Harz Mountains, Moravia and Tyrol.

**ENTABLATURE**, in architecture, the horizontal, continuous work which rests upon a row of columns and belongs especially to classical architecture. It consists of three principal divisions, the epistyle or architrave immediately above the abacus of the column, next the frieze, and then the cornice. In large buildings projections similar to and known also as entablatures are often carried round the whole edifice or along one front of it. Consult Boetticher, K. G. W., 'Die Tektonik der Hellenen' (Berlin 1874); Hirt, A. L., 'Die Baukunst nach den Grundsätzen der Alten' (Berlin 1809); Kohte, J., 'Die Baukunst des Klassischen Altertums, etc.' (Braunschweig 1915); Marquand, A., 'Greek Architecture' (New York 1909); Uhde, C., 'The Architectural Forms of the Classic Ages, etc.' (edited by R. P. Spiers, Berlin 1909).

**ENTADA**, a genus of leguminous plants containing about a dozen species of climbing tropical shrubs, remarkable for the great size of their pods. *E. scandens* has pods which measure from six to eight feet in length. The seeds have a hard, woody and beautifully polished shell, and are often made into snuff-boxes, scent-bottles, etc.

**ENTAIL**, the settlement of an estate so that it shall pass according to a certain rule of descent. In England after the Norman Conquest estates were frequently granted to a man and the heirs of his body, but in time the law courts interpreted such grants as conferring a fee-simple conditional, so that when the condition, namely, the begetting of an heir, was fulfilled, the estate became a fee-simple absolute and could be alienated by the grantee. The statute "De Donis Conditionalibus," passed in 1285, declared that this interpretation was contrary to the intention of the grantors, and enacted that in all future grants of this nature the grantee should have no power to alienate the estate, and that on the failure of issue the land should revert to the grantor. The effect of this statute was to prevent the free conveyance of land, but gradually the lawyers created a series of proceedings known as fines and recoveries, by means of which a tenant in possession could bar the entail and convert his estate-tail into a fee-simple, that is, into his absolute property. (See FEE). These remedies created by the courts were abolished by the Fines and Recoveries Act, passed in 1833, and a direct means of barring entails was introduced. This statute enacts that every actual tenant-in-tail shall have full power

to dispose of, for an estate in fee-simple absolute, or for any less estate, the lands entailed; but a tenant-in-tail in remainder, expectant on an estate of freehold, cannot bar the entail, though he may bar his own issue, without the consent of the "protector of the settlement," who is usually the tenant for life.

**ENTASIS**, ěn'tā-sīs, in architecture, the delicate outward curve of a column, found in perfection in the Doric column, by which an arc is described whose highest point is about midway between capital and base. This swelling of the column is intended to counteract the optical error by which a rigidly straight perpendicular line has a tendency to appear concave. The entasis is also calculated to suggest life and motion in the column under the superimposed weight of the entablature. Consult Goodyear, W. H., 'Greek Refinements' (New Haven 1912); Penrose, F. C., 'An Investigation of the Principles of Athenian Architecture' (London 1851).

**ENTELECHY**, ěn-těl'ě-kī, a Greek word meaning "the bringing to completion," in the peripatetic philosophy of Aristotle is the transition or connecting action between what he calls *δύναμις*, potentially and *ἐργον*, actuality; that which, among the schoolmen, is conceived as intervening between the *posse* and the *esse*, for example, between the infinite possibilities of omnipotence in the Supreme Being and their manifestation in creation and active providence.

**ENTELLUS MONKEY**, a book-name for the langur (*Semnopithecus entellus*), the sacred monkey of Hindustan, representative of the god Hanaman. See LANGUR.

**ENTELODONTS**, a group of split-hoofed, swine-like animals of early Tertiary time, the giant pigs, represented in both the Old and New Worlds. In North America their fossil remains are found in rocks from Eocene to Lower Miocene age from New Jersey to the Rocky Mountains. The head was very long, the neck short, the body compact, the long spines of the dorsal vertebrae forming a decided hump on the shoulders, and in some the legs were very long and slender, giving a stilted appearance to the animal. The teeth were large and strong, especially the incisors and premolars (sharp cutting-teeth) and the canines were large but not developed in formidable exterior tusks as in modern wild boars. The brain-case was "absurdly small," says Scott; and "evidently these great pigs were profoundly stupid." Beneath each eye was a long, descending, bony process, and the lower jaw had in its under side two pairs of bony protuberances, which Osborn believes were for the attachments of the great muscles needed in tearing up roots, which there is reason to believe formed their principal food (Brackett). The genus *Dinohyus*, of the Upper Oligocene of Nebraska, contained species six feet or more in height, and others were scarcely less. Consult Scott, 'Land Mammals in the Western Hemisphere' (New York 1913).

**ENTENTE CORDIALE** (Fr., cordial understanding), a term commonly applied to the reconciliation, in 1904, between France and Great Britain after many years of enmity. In diplomatic language the phrase signifies a close friendship between two or more nations, though without any formal alliance existing between

them. See ALLIANCES; TRIPLE ALLIANCE; TRIPLE ENTENTE.

**ENTERALGIA**, ěn-tě-rāl'jī-a. See ENTERITIS.

**ENTERIC FEVER**. See TYPHOID FEVER.

**ENTERITIS**, an inflammation of the small intestine, the most important symptom of which is diarrhoea. Different varieties of enteritis are described as catarrhal enteritis, the acute enterocolitis of children, or cholera infantum, croupous enteritis, and enteritis due to tuberculosis, carcinoma, and other malignant diseases. In primary enteritis the symptoms may be acute or chronic, the most important single symptom being diarrhoea. The stools are thin and watery, and particles of undigested food may be found in them. There is usually colicky pain with gas, and occasional vomiting. Loss of appetite, thirst and dry tongue are usually present, but fever is not common. The general causes of catarrhal enteritis are improper food, particularly in children, unripe fruit, toxic substances, changes in the weather, and nervous influences bringing about changes in the character of the secretions and in the muscular activities of the walls of the intestines. Infectious diseases may also be the cause of acute enteritis. Rest in bed, following a mild laxative such as calomel or castor oil, together with milk diet, will usually be sufficient treatment for the simple cases.

Acute enteritis of infants, known as cholera infantum (q.v.), is a much more serious disease. This is a form of dysentery, in which not only the small intestine but the large intestine also is involved, and the most active cause of this disease is a specific micro-organism called the bacillus of Shiga. Treatment of acute enteritis of infants requires trained medical advice. The most important feature, however, in infants is to cut down the feeding, giving practically nothing but water for at least 24 to 36 hours. Horses, cattle and sheep, too, are subject to enteritis, and, unless properly and promptly treated, are apt to succumb to it. See CHOLERA INFANTUM; COLITIS; DYSENTERY; INTESTINES — Diseases of.

**ENTEROCLYSIS**, a form of intestinal hydrotherapy of much importance. It consists in lavage of the intestines. The ordinary hot-water enema is the simplest form of enteroclysis, but true enteroclysis consists in continuous irrigation with large quantities of solution, either with a single or a double tube. The effect of the introduction of large amounts of hot salt solution (a dram of common table-salt to a pint of water at a temperature of from 110° to 118° F.) is very marked. There is much increase in the tension of the pulse, and pronounced stimulation of the heart-action, both of prime importance in the treatment of hemorrhage, shock, asphyxiation from drowning or from coal-gas poisoning, and of many forms of drug and industrial poisoning. Enteroclysis has also a marked effect in augmenting the secretion of the kidney, and proves of immense importance in the treatment of chronic uræmic poisoning, such as is seen in Bright's disease, and also in the treatment of diabetic coma. It is likewise of importance in bladder troubles, in colitis, in peritonitis, septic endocarditis, and in ulcerative conditions of the large intestine, such as are found in dysentery and in cholera.

Enteroclysis is also an excellent mode of treating collapse in chronic alcoholism.

**ENTERPRISE**, The, the name of a number of American and English boats, the most famous of which was an American 12-gun schooner with such a brilliant career that she became known as the "Lucky Little Enterprise." Built 1799 to deal with the French privateers in the West Indies, she had an extraordinary cruise in 1800 under the command of Lieut. John Shaw: in a six months' run she took eight privateers, some of them much heavier than herself, and aggregating 47 guns, and also recaptured four American merchantmen. In 1801 she was sent under Lieut. Andrew Sterett with Captain Dale's squadron to the Mediterranean against the Barbary pirates, captured a 14-gun Tripolitan after a fierce engagement, and later was at the bombardment of Tripoli. In December 1801 she returned to the United States, but went back to the Mediterranean in 1802 under Lieut. Isaac Hull. In 1803 she was under the command of Lieut. Stephen Decatur (q.v.), who in December of that year captured with her the Tripolitan *Mastico* which later became famous in connection with Decatur's recapture of the *Philadelphia*. Between 1805 and 1809 the *Enterprise* was in home waters. From 1809-11 she was once more in the Mediterranean, this time under Lieutenant Trippe. Her most memorable battle was during the War of 1812 and was fought with the English brig *Boxer*, Captain Blythe, on 5 Sept. 1813, off the Maine coast, toward Monhegan Island. By that time she had been converted into a brig, carried 16 guns and was under Lieut. William Burrows; the *Boxer* had 14 guns. The crews were about 100 each. The fight began at 3:20 P.M., and was ended at 4 by the surrender of the *Boxer*, literally cut to pieces in hull, masts, rigging and spars, several of her guns dismounted, boats and quarters shattered; the *Enterprise* was almost uninjured, with but one shot in the hull and one in the main-mast. Both commanders were killed and were later buried side by side at Charleston. Burrows who had received his mortal wound during the progress of the fight was succeeded by Lieutenant McCall. After this heroic battle the *Enterprise*, together with some other boats, cruised for some time in southern waters under Lieut.-James Renshaw and there, even though she had lost much of her former speed by the structural changes made upon her, escaped at a number of occasions from English boats which were attempting to capture her. She then served until the end of the war as harbor guard at Charleston. From 1816-19 she was again attached to the Mediterranean squadron, this time under Lieut. Laurence Kearney. In 1821 she cruised in the West Indies and successfully broke up the pirates then swarming in those waters. In 1823 she was wrecked on Curaçoa, but all hands were saved. A famous English boat bearing the name *Enterprise* was one of three masts which, under the command of Capt., later Adm., Richard Collinson, made, from 1850-55, one of the many unsuccessful searches for Sir John Franklin's ships in the Arctic. Consult Collinson, Sir R., 'Journal of H. M. S. *Enterprise*' (London 1889); Hill, F. S., 'Twenty-Six Historic Ships' (New York 1903); 'The Romance of the American Navy'

(New York 1910); 'The "Lucky Little Enterprise"; etc.' (Boston 1900); Maclay, E. S., 'A History of American Privateers' (New York 1899); 'A History of the United States Navy' (3 vols., New York 1902); Morris, C., 'Heroes of the Navy in America' (Philadelphia 1907); Speers, J. R., 'The History of Our Navy' (4 vols., New York 1897); 'A Charmed American Warship' (in *Harper's Magazine*, Vol. CIV, pp. 927-936, New York 1902).

**ENTFUHRUNG AUS DEM SERAIL**, ent-für'oong ous däm sä-ril', Die (Il Seraglio). An opera by Mozart, which was produced for the first time at Vienna on 13 July 1782 and at New York in October 1862.

**ENTHYMEME**, in logic, the technical name for a syllogism of which either one premise or the conclusion is not expressed. For example, "The *Lusitania* must have been steaming under 20 knots for it was torpedoed"—the unexpressed premise being "A steamship steaming over 20 knots cannot be torpedoed." See Logic.

**ENTOMBMENT**, The, a favorite subject of the painters of all the centuries has been this representation of the placing of Christ's body in the sepulchre. Of all perhaps the most famed is that by Raphael (1507), now in the Palazzo Borghese, Rome. The finest is that in the Louvre by Titian (1523). The Madrid Gallery has another Titian but it is inferior in conception to that of the Louvre. Other representations of this subject are those by Caravaggio, Tintoretto, Ferrari (Turin), Carracci (Louvre), Donatello (a sculpture group in the South Kensington Museum, London), and Van Dyck (in Antwerp).

**ENTOMIS**, a genus of fossil ostracods, having a vertical furrow along their shell valves. It is found in the Ordovician and Carboniferous and all intermediate strata, especially the Devonian. See OSTRACODA.

**ENTOMOLOGICAL SOCIETIES**. Half a century ago a single entomological society was all that had been organized in the United States, but at present there are probably upward of a score of organizations devoted to this science. The first entomological society of which we have record was formed in 1842. This was The Entomological Society of Pennsylvania, which has long been out of existence. The American Entomological Society of Philadelphia, founded in 1859 under the name of The Entomological Society of Philadelphia, and incorporated in 1862, published 'Proceedings' until 1868, when the society name was changed and the publications became known as 'Transactions.' This, as well as some of the other societies that will be mentioned, is supported by a permanent endowment fund, owns very extensive and valuable collections and a library, which are deposited with the Academy of Natural Sciences of Philadelphia, of which institution its members are associate members of the entomological section. Under the combined auspices of these organizations there is now published *Entomological News*. The Entomological Society of Ontario publishes the *Canadian Entomologist* which began publication in 1868, though the society had a previous existence under the name of The Entomological Society of Canada. It is supported by an annual

government grant and the sale of its publications. The Brooklyn Entomological Society was organized in 1872 and in 1888, while retaining a corporate existence, became merged in the Brooklyn Institute, forming the department of entomology of that institution. It published seven volumes of a 'Bulletin' and six volumes of 'Entomologica Americana.' The Cambridge Entomological Club, founded at Cambridge, Mass., in 1874, publishes *Psyche*, a quarterly originally devoted largely to bibliographical and biological entomology. The same year The Entomological Club of the American Association for the Advancement of Science was formed. In 1884 The Entomological Society of Washington was organized, publishing 'Proceedings.' The Association of Economic Entomologists, as has previously been mentioned, was established in 1889. Its 'Proceedings' are published in the general series of bulletins of the Division of Entomology of the United States Department of Agriculture. In 1881 The New York Entomological Club began the publication of 'Papilio,' but at the end of its 4th volume its members joined the Brooklyn Entomological Society. In 1892, however, another society was organized in New York as The New York Entomological Society. It was incorporated in 1899.

In addition to these principal publishing entomological associations there are several other entomological sections of larger scientific societies in Canada and in the United States. There are also local clubs or societies in various sections, for example, in Newark, N. J.; at Williamsburg, N. Y.; at Chicago, Pittsburgh and in San Francisco, the home of the California Entomological Society.

There are many foreign societies, nearly all of the largest cities of Europe supporting one or more, usually holding titles significant of an entire nation, for example, there are entomological societies of Belgium, France, Switzerland, Russia, Italy and Germany, and others representing the cities of London, Berlin, Vienna and Stockholm. See also AMERICAN ENTOMOLOGICAL SOCIETY and consult Skinner, H. (ed.), 'Entomologists' Directory, containing the names, addresses, special departments of study, etc., of those interested in the study of insect life in the United States and Canada' (Philadelphia 1904).

**ENTOMOLOGY**, the science which deals with insects. See INSECTS.

**ENTOMOLOGY, Economic.** Attacks by insects upon useful plants doubtless began with the first cultivation of plants; but it was not until the end of the 18th century that any means for mitigating their ravages were employed beyond hand methods and other purely mechanical measures. A few crude efforts were made among the ancient farmers and fruit-raisers on the shores of the Mediterranean toward the suppression of insect pests and Pliny even advised the use of white hellebore, one of the modern insecticides; but it was at about the middle of the 19th century that insecticides (q.v.) or insect poisons began to be generally adopted, and the migration of the Colorado potato beetle from its native home in the Rocky Mountain region to the potato fields of the East was the indirect means of the employment of arsenical preparations as a means of destroy-

ing insects; so that this insect, while an apparent curse, has proved, indirectly, of the greatest value to the agricultural community at large. Prior to the use of Paris green, which appears to have first been applied to this potato pest in Michigan in 1867, knocking the beetles from the infested plants into a pan of water was the only method of treatment and was used for many other insects as well. The discovery of the value of this poison as a remedy for the codling moth was made in 1878, by Prof. A. J. Cook, who used Paris green as a remedy for canker-worms and found that the trees treated with it were free from codling moth. To Professor Cook also is probably due the first use of kerosene mixed with soap, although the kerosene emulsion, which is now a standard remedy for all sucking insects, was the joint product of Messrs. Barnard, Hubbard and Riley, and first used in 1877. White arsenic was employed as an insecticide as early as 1871 and London purple was put to practical use in the destruction of the cotton worm in 1878. London purple has since been displaced by various other insecticides, as it has proved inferior to Paris green, which, in turn, has been replaced by arsenate of lead, because the latter, while poisoning the insects, does not scald or otherwise injure the plants. In the same manner the discovery of Paris green as a remedy for the Colorado potato beetle was made through the migrations of this insect, the ravages of the cotton cushion scale (*Icerya purchasi*) of the orange orchards of California led to experiments conducted by Mr. D. W. Coquillett, of the United States Department of Agriculture, in 1886, to the finding of hydrocyanic-acid gas as the best medium for extirpation of scale insects (q.v.), and to its general use in fumigation for all insects which can be treated with it. In 1895 Messrs. A. F. Woods and P. H. Dorsett, also of the Department of Agriculture, began experiments which led to the adoption of a perfected system of fumigation with the same gas of plants grown under glass and injured by scale and other insects.

Our best remedies for insects, then, arsenical mixtures and kerosene emulsion and other preparations, and hydrocyanic-acid gas, are the product of American research. The bisulphide of carbon as an insecticide, however, though the discovery of a foreigner, has doubtless received greater attention in our country than elsewhere. It was first employed by M. Doyère, as early as 1856, as a remedy for weevils in stored grain, which is still its principal use; but its cost when first employed was so excessive as to preclude its general employment on a large scale. Subsequently a high grade of this chemical, known as "fuma-bisulphide," was made for sale at 10 cents a pound. It supplements the use of hydrocyanic-acid gas in that the former is used for the fumigation of plants above ground, while the latter destroys insects affecting the root-system. Both gases are used for the treatment of indoor insects in granaries and mills and in dwellings and warehouses. Although these are the main insecticides, there are others, nearly all of which owe their discovery and perfection to economic workers in America. They include pyrethrum, better known as Buhach, Persian and Dalmatian insect powders, the extensive use of which has resulted in the establishment of a considerable

industry in the growing of the principal plants which produce these powders (*Pyrethrum cinerariaefolium* and *Pyrethrum roseum*); and whale-oil and fish-oil soaps, originally used against the hop aphid in 1886, and later against scales.

In more recent years lime-sulphur combinations have been used as washes and sprays against scales and other sucking insects with good results. Still more recently nicotine sulphate standardized at 40 per cent purity has come into general use as a contact insecticide for the same class of insects, and is now a standard remedy in combination with soap for the control of aphides or plant-lice, the onion and pear thrips and related species, leafhoppers, plant-bugs and many others. Prior to this time tobacco preparations were used but with indifferent success except on a restricted number of insect pests.

Quassia is the subject of investigation as a contact insecticide. Of arsenical poisons arsenite of zinc and arsenate of calcium are effective but not superior to arsenate of lead. Adhesives, such as whale-oil (fish-oil) and other soaps, are also in general use under the name of "stickers." Repellents, to prevent such insects as the parent flies of root-maggots from depositing their eggs, are being successfully employed and in some cases odorous substances are being used to attract insects from their natural foods where they can be destroyed.

As fumigants, hydrocyanic-acid gas generated from sodium cyanid is in general use for the destruction of mill and granary insects, greenhouse and household pests. Carbon tetrachloride and para-dichlorobenzene are excellent fumigants, but too costly for general use. Insects affecting stored products and pests in households may also be controlled by heat—an old remedy which is now employed in many mills and warehouses where steam-heating plants are installed.

During the early years of work in spraying for various insects the principal dependence was placed in American insecticide machinery, but after the invention of different forms of nozzles by M. Vermorel, of France, various other nozzles, pumps and other machinery were invented in America and have gone into general use.

An almost incredible number of spraying machines and appliances are being manufactured and constant improvements are being made adapted to special purposes.

**Prevention of Insect Injuries by Farming Methods.**—It would be difficult to detail step by step the wonderful progress that has been made in means of subduing insects by simple farming methods which, as a rule, necessitate little or no extra labor or monetary outlay. Some of our principal pests, with which we cannot cope successfully by means of insecticides or by mechanical methods, may be controlled by the judicious use of ordinary methods of tillage. The seed, nursery or other stock for planting should be selected with a special view to securing immunity from attack by the insect most feared or most prevalent in the region where the crop is to be planted. By planting different immune varieties of wheat the ravages of the Hessian fly are reduced to a minimum. Certain forms of trees may be selected for planting for shade in some regions without danger of injury, because the insects

which elsewhere do greatest damage to them are not present. The selection of a suitable location on the farm for a crop should be made with the same end in view. Where injury is feared by an insect which does not travel freely, immunity can be secured by planting in that part of the farm where the insect is known not to exist. The prompt destruction of crop remnants and the pulling up and burning over of weeds and other rubbish is a preventive applicable to all crops. Another measure is the use of "trap crops." Thus part of an old crop may be left to attract insects which usually remain in the field after the crop is made; similar or more attractive plants may be grown for the protection of the main crop; or of early varieties of the same plants, as lures for the insects until the main crop can obtain a good start. On the lure plants the congregated insects must be destroyed by poisons or by fire. Trap crops are of considerable value in the treatment of several of the worst enemies of cucumbers, melons, squashes and similar vines. The stimulation of a plant by means of fertilizers and the maintenance of healthy, vigorous growth by cultivation, the suppression of diseases and the prevention of injury by insect pests other than those which it is specially designed to circumvent, are helpful aids. Crop rotation or the planting of alternate crops which are not injured by those insects which ravage the staples assists in the warfare; as also do fall and spring plowing, which, in proper combination, result in the destruction of nearly all forms of the many insects which pass one or more stages in the earth in hibernation. The use of water by irrigation or submersion, if practised at the right time, will result in the temporary extirpation of nearly all insects in the fields thus treated, particularly in cranberry bogs. The reclamation by drainage of land subject to more or less complete submersion, such as swampy tracts, river bottoms and the like, and the destruction of the weeds and other plants and the insect life which remain by burning over, are of great value in suppressing many pests. If, to the methods above outlined, we add the strict observance of timely harvesting of crops with a view to the prevention of further attack and the destruction of insects which might reproduce the following year; the utilization of natural enemies, such as parasitic and predaceous insects, poultry and live stock, to destroy the insects in the field after the crop is off; the systematic inspection of the farm for the first appearance of insect attack, and, finally, the co-operation of neighboring farmers having a community of interests in growing the same crops, there is comparatively little use for insecticides save in the case of insects such as grasshoppers and the caterpillars of moths and butterflies, which are strong fliers and cannot be successfully controlled by mechanical methods.

**Economic Entomologists.**—Dr. T. W. Harris is credited with having been the first economic entomologist of America, but in reality the honor is due to W. D. Peck, who began writing on injurious insects late in the 18th century (1795-1819). His writings, however, are few, in comparison to those of Harris, whose labors began in 1831 and whose greatest work appeared in 1841, his classic treatise on 'Insects Injurious to Vegetation.' In the year



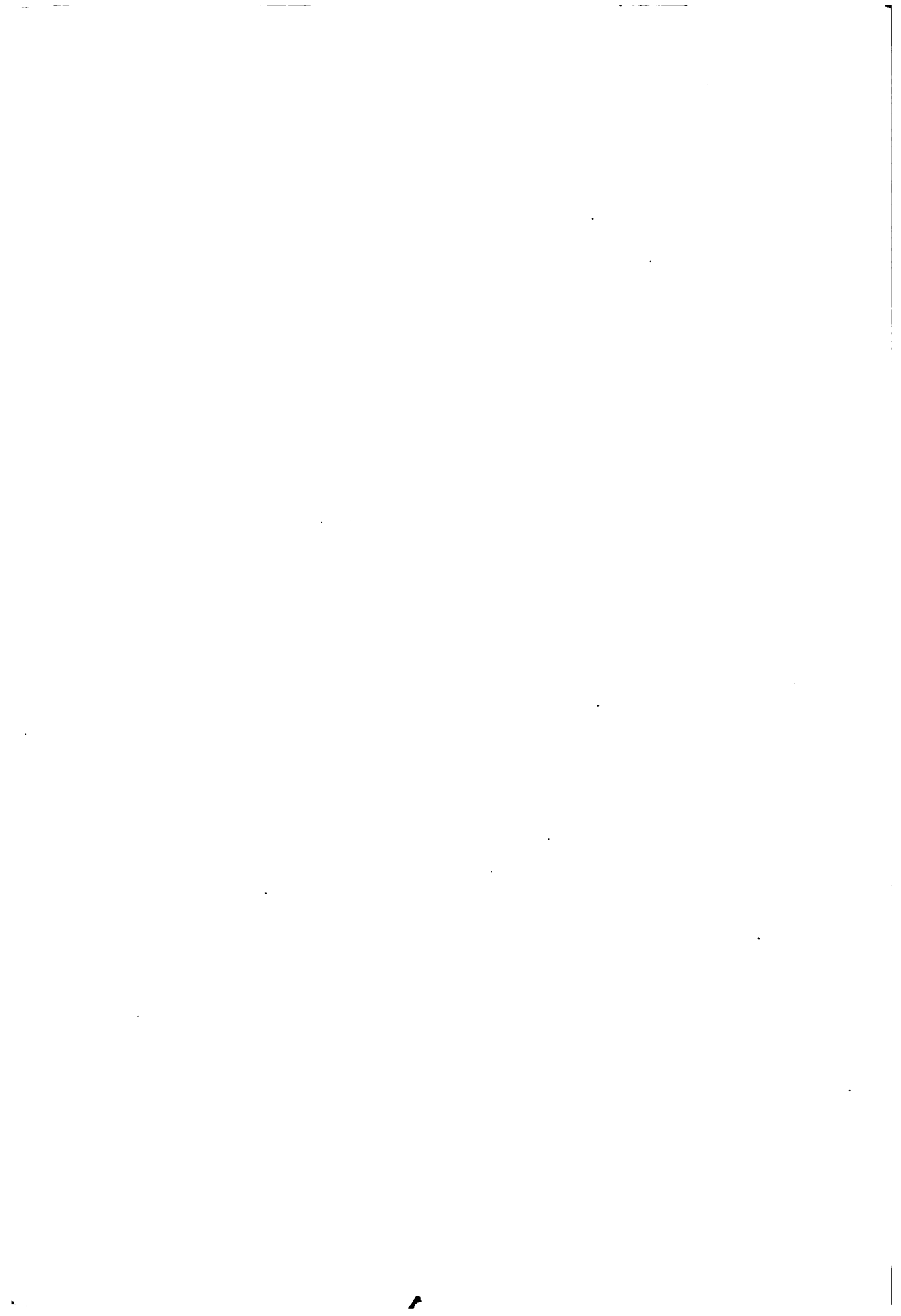

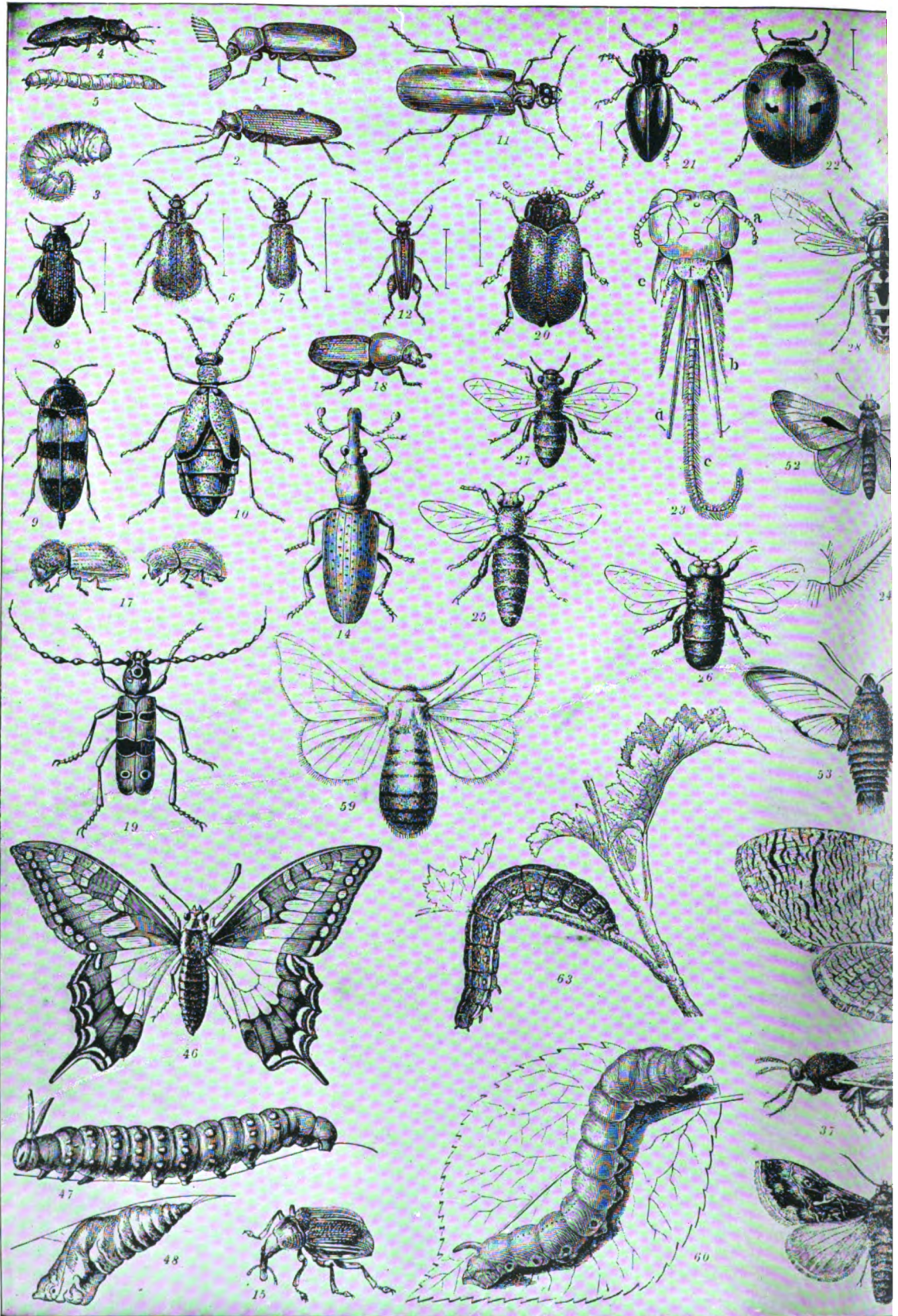
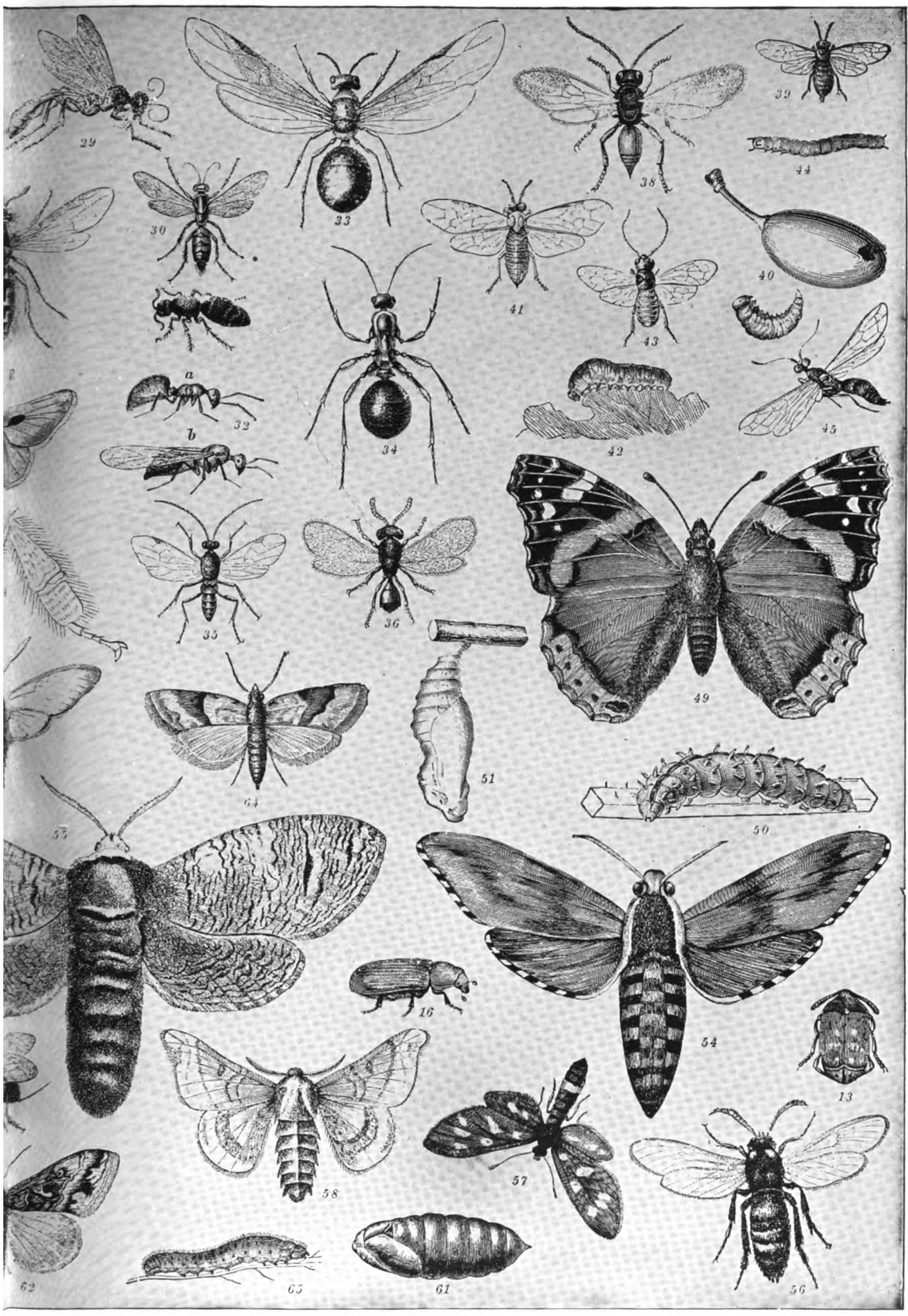
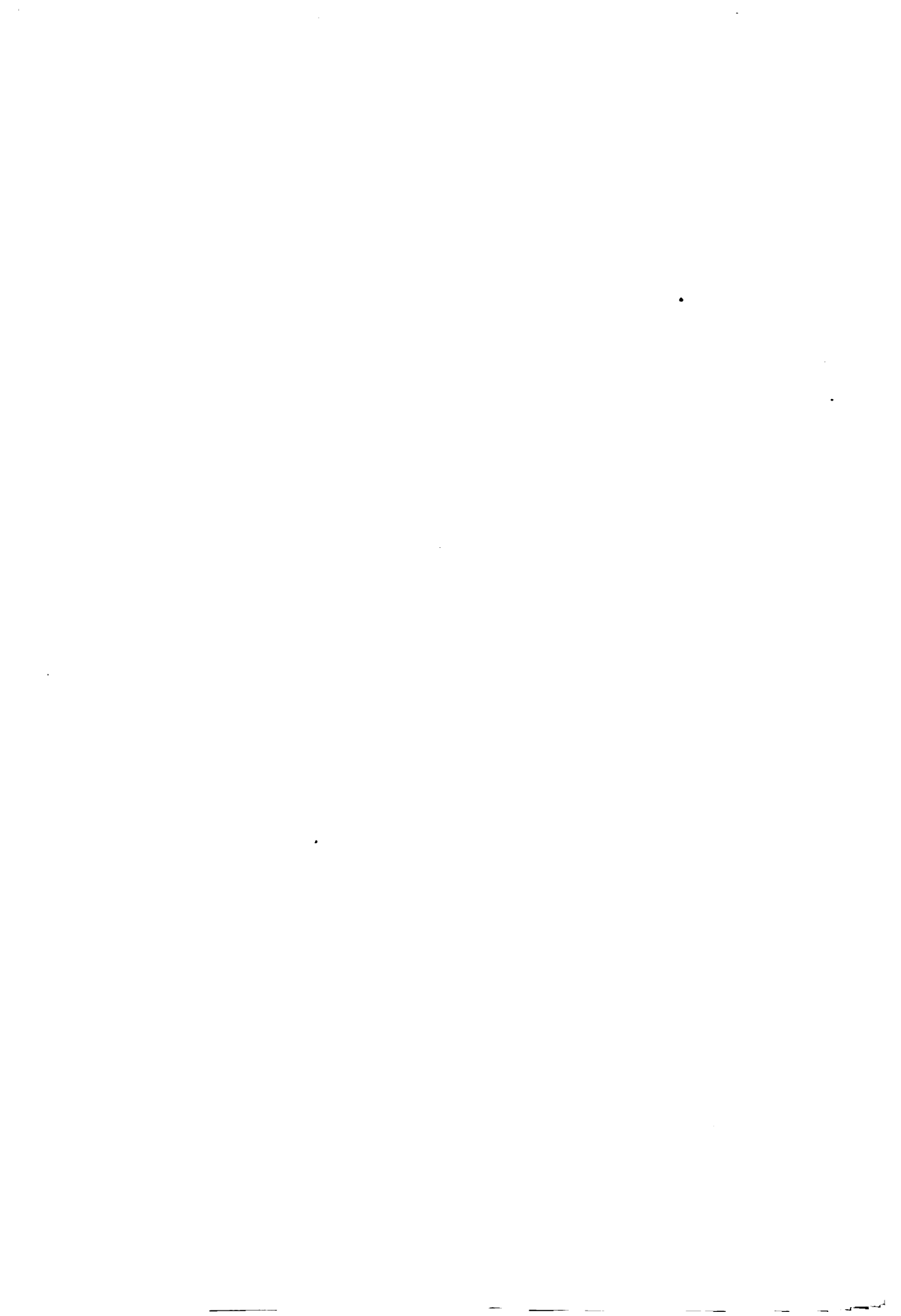

Fig. 1 Boring-beetle (*Ptilinus*) 2, 3 Boring-beetle (*Ptilinus* and Larva) 4, 5 Tenebrio and Larva (mealworm) 6 Leg  
 12 Oedemera 13 Pea-beetle 14 Corn-weevil 15 Vine-weevil 16 Clover-weevil 17 Bostrychus 18 Plum-tree B  
 of Worker 25, 26, 27 Queen, Drone and Worker 28 Wasp 29 Sand-wasp 30 *Pompilus Viaticus*  
 35 *Microgaster* 36 *Teles* 37 Brilliant Ichneumon 38 *Rhodites Rosae* 39, 40 Plum-tree Saw  
 46, 47, 48 Swallow-tail Butterfly, Larva and Pupa 49, 50, 51 Admiral Butterfly with Larva and Pup  
 57 *Syntomis* 58, 59, 60, 61 Silkworm Moth — Male, Female, Caterpillar and Chrysalis



7 Scarlet-beetle    8 Melandry    9 Mordella Fasciata    10 Meloe (Oil-beetle)    11 Cantharis (Spanish Fly)  
 12 Alpine Goat-beetle    13 European Mutilla    14 Mutilla Larva    15 Mutilla Pupa    16 Beetle    17 Beetle    18 Beetle  
 19 Female Worker    20 Male Worker    21 Fungus-beetle    22 Lady-bird    23 Worker of Brown Ant  
 24 Turnip Saw-fly and Larva    25 Pear-tree Fly and Larva    26 Corn Saw-fly  
 27 Hesperia    28 Hawk-moth    29 Pine Hawk-moth    30 Willow-moth    31 Bee-moth  
 32 Ynsilan    33 Caterpillar of Cabbage Butterfly    34. 35. 36. 37. 38. 39. 40. 41. 42. 43. 44. 45. 46. 47. 48. 49. 50. 51. 52. 53. 54. 55. 56. 57. 58. 59. 60. 61. 62. 63. 64. 65. Vine-roller and Caterpillar



1853 the New York State legislature appropriated \$1,000 for the study of economic entomology and Dr. Asa Fitch was appointed to perform the work specified. Fitch's work continued until 1871 or 1872, when his 14th and last report was published. Afterward different States, Illinois in 1866-67, and Missouri about a year later, appointed State entomologists, the latter State obtaining the services of Dr. C. V. Riley, who wrote a series of nine reports which, for originality, scientific accuracy and practical value, have received recognition the world over.

When Dr. Riley assumed the duties of entomologist of the United States Department of Agriculture, economic entomology received a new impetus, his work and that of his assistants marking a new era in practical entomological work. Upon his death in 1894, he was succeeded by Dr. L. O. Howard, under whose direction the Bureau of Entomology continues to issue reports, bulletins and circulars of the highest practical and scientific value. See AGRICULTURE, DEPARTMENT OF.

Prior to 1888 Massachusetts, New York, Illinois and Missouri were the only States which maintained officially appointed economic entomologist. During that year the State agricultural experiment stations (q.v.) were organized under the Hatch Act and several official entomologists were appointed in connection with them. In 1889 was formed an Association of Economic Entomologists which held annual meetings in various cities subsequently and had in 1916 a total membership of about 470.

**Bibliography.**—Harris, 'Insects Injurious to Vegetation' (Flint ed., 1852); Treat, 'Injurious Insects of the Farm and Garden' (1882); Saunders, 'Insects Injurious to Fruits' (1883); Cooke, 'Injurious Insects of the Orchard, Vineyard, etc.' (Sacramento 1883); Smith, 'Economic Entomology' (1896); Weed, 'Insects and Insecticides' (Hanover, N. H., 1891); Sanderson, 'Insects Injurious to Staple Crops' (1902); Chittenden, 'Insects Injurious to Vegetables' (New York and London 1907); Sanderson, 'Insect Pests of Farm, Garden and Orchard' (New York and London 1912); Slingerland & Crosby, 'Manual of Fruit Insects' (New York 1914); Essig, 'Injurious and Beneficial Insects of California' (2d ed., Sacramento 1915). Also the serial publications of the United States Department of Agriculture and of the entomologists of the State agricultural experiment stations and of State entomologists, including Fitch, Riley, Forbes, Lintner, Felt, J. B. Smith, Webster and others.

F. H. CHITTENDEN,  
*Entomologist, in Bureau of Entomology, United States Department of Agriculture, Washington, D. C.*

**ENTOMOPHTHORALES**, en-tō-mōf"-thō-rā'les, group of parasitic fungi, which is highly destructive of insects. In germination the spore emits a tube which penetrates the insect's body, which is thereupon filled with the mycelium of the fungus.

**ENTOMOSTRACA**, one of the two great sub-classes of crustacea (the other is Malacostraca), including minute forms; the "water-fleas," having a horny shell of many pieces, a well-developed cephalo-thorax, mandible and three pairs of maxillæ, five pairs of thoracic

feet but no abdominal feet and no gills, breathing instead by specialized organs. They have a great variety of shapes and of means of locomotion. The young is a nauplius and developed by numerous molts. The group includes many thousands of species, divided into four orders,—Phyllopora, Ostracoda, Copepoda and Cirripedia (barnacles). They abound in stagnant fresh waters and also in the sea, and furnish an immense quantity of subsistence for fishes that are used for human food. They exist and increase in innumerable millions. The descendants of a single cyclops may in one year number over 4,000,000,000. At one time they render the surface of the sea-water phosphorescent by their vast luminous congregations. At another time the Atlantic Ocean is colored red over a space of hundreds of square miles by the assembly of these minute creatures, attracting multitudes of fishes, even of whales, which feed upon them. On the other hand, some forms are equally injurious as parasites. Those belong chiefly to the copepod group—siphonostomata, having mouths fitted for suction. Some are commensal, entering the gill-sac or digestive cavity and feeding upon the food, not upon the tissue, of the host. Some attach themselves long enough to suck the blood of their victim and then pass on, while others enter the body as permanent residents and embed themselves in the tissue. Thus they are the pests of starfish, jellyfish, worms, ascidians, fishes and whales. See BARNACLE; COPEPODA; CRUSTACEA; FISH-LICE; OSTRACODA; PHYLLOPODA.

**ENTOZOA**, formerly employed as the name of a subdivision of radiate animals, has passed out of use as a term of systematic classification, because it fails to indicate or signify any ideas of structure and only hints at the habitat and occupation of great numbers of living creatures. Following the strict meaning of the word entozoa, denoting "animals within" (i.e., internal parasites) other animals, not only brings together many genera that belong with the different subdivisions of the same general division, but also imports those which are included under classes morphologically distinct. Even this use of the word is obsolescent. See BOT FLY; DISTOMA; ELEPHANTIASIS; FILARIASIS; GUINEA-WORM; HOOK-WORM; OXBOT; PARASITISM; PLATYHELMINTHES; ROUND-WORMS; TAPEWORMS; TREMATODA.

**ENTRE-DOURO-e-MINHO** (i.e., between the Douro and Minho), ên'trê dô'roo ê mên'yoo, a province of Portugal, more generally known by the shorter appellation of Minho. The surface is broken and partially occupied by high mountains, but the soil in the valleys is well cultivated and the province the most densely populated in the country. Area 2,808 square miles. Pop. 1,289,066.

**ENTRE MINHO e DOURO**, name frequently employed by the Portuguese for the province Entre Douro e Minho or Minho (q.v.).

**ENTRE RIOS**, ên'trâ rê'ôs, Argentine Republic, a province bounded on the north by Corrientes, on the east by the republic of Uruguay, on the south and west by the provinces of Buenos Aires and Santa Fé. As its name indicates its territory lies "between the rivers"—Rio Paraná and Rio Uruguay. Area 29,241

square miles. Agriculture and immigration were encouraged by the provincial government, which sold land to settlers in portions of 82½ acres, to be paid for in three years, at prices ranging from \$600 to \$2,000, according to location. A considerable amount of land has been taken up by the Jewish Colonization Association. Until the building of the Entre Rios Railway this province was the "poor sister" of the republic; but since then it has made very rapid strides. It is second in the production of oats and grows large quantities of wheat of excellent quality, other products being maize, lucerne, barley, flax, grapes, tobacco, fruit and (on a very large scale) cattle, sheep and horses. Its capital, the city of Paraná (pop. 65,000), was the capital of the republic from 1852 to 1861; it has a national college, a normal school and several elementary schools, a charming park, tramway service, and is an important port for the traffic on the Paraná River. Pop. of the province estimated 423,100.

**ENTRECASTEAUX**, döntr-käs-tö, **Joseph Antoine Bruni d'**, French navigator: b. Aix 1739; d. at sea, near the island of Java, 20 July 1793. He entered the French naval service in 1754, gradually rose to the position of commandant of the French fleet in the East Indies (1786), and in 1787 became governor of Mauritius and the Isle of Bourbon. In the same year he made a voyage to China. In 1791 he was sent by the French government in search of La Pérouse (q.v.), who had not been heard from since February 1788. For this purpose he was given the command of two ships, the *Recherche* and *L'Espérance*. He failed in detecting any trace of the lost navigator, but ascertained with great exactness the outlines of New Caledonia, the west and southwest coast of New Holland, Tasmania and various other coasts. The D'Entrecasteaux Archipelago was named in his honor. Other reminders of his visit to Tasmania are D'Entrecasteaux Channel, Bruni Island, Recherche Bay, Port Espérance, all names given by him to these various localities and still in use to-day. The journal of this voyage has been edited by de Rossel, 'Voyage de D'Entrecasteaux' (2 vols., Paris 1808). His maps and other topographical drawings have been published as 'Atlas du Voyage de Bruny-D'Entrecasteaux' (Paris 1807). Consult Cordier, H., 'La Mission de M. le Chevalier d'Entrecasteaux à Canton en 1787' (Paris 1911); Goepf, E., and Cordier, E. L., 'Les Grands Hommes de la France: Navigateurs' (Paris 1873); Labillardière, J. J. H. de, 'Relation du Voyage à la Recherche de la Pérouse' (2 vols., Paris 1800), and its translation into English, 'Voyage in Search of la Pérouse' (2 vols., London 1800); Marriott, I. L., 'Commodore Sir John Hayes, His Voyage and Life' (London 1912).

**ENTREMONTE**, dön-tr-môn', **Comte d'**. See L'HOPITAL.

**ENTRENCHED MEANDERS**. See MEANDERS.

**ENTRESOL**, ön tr-söl or ön'tér-söl (Fr. "between the floors"), a low story between two of greater height, generally the ground and the first stories. It is of frequent occurrence in modern French architecture, especially in city houses. It is called also the Mezzanine.

**ENTROPION**, or **ENTROPIUM**, inversion or turning in of the edge of the eyelids, in consequence of which the lashes rub on the eyeball, causing annoyance and pain.

**ENTRY**, **Right of**, in the common law, the right of taking possession of lands or property by entering or setting foot on the same. This may be done either by the claimant personally, or through his agent or attorney.

**ENTRY**, **Writ of**, a formal declaration made by one exercising the right of entry in recovering property of which he has been dispossessed that he claims full possession of the said property. The common-law action of Writ of Entry has for some time been obsolete in Great Britain, but is still in use in a modified statutory form and generally for special purposes in a few jurisdictions in the United States.

**ENTWISTLE**, **James**, American naval officer: b. Paterson, N. J., 1837; d. 23 March 1910. He entered the engineering service, United States navy 1861, became commander in 1888, and in 1899 was made captain and rear-admiral and placed upon the retired list. He first served on the *Aroostook* under Farragut in the Western Gulf squadron, and on 21 other vessels; was inspector of machinery at the Bath (Me.) Iron Works 1890-95 while the ram *Katahdin* and the gun-boats *Machias* and *Castine* were in process of construction, and assistant to the general inspector at Mare Island Navy Yard in 1895. He joined the Asiatic squadron at Yokohama during that year, being appointed fleet engineer 1897 and assigned to the *Olympia*. He took part in the battle of Manila Bay, 1 May 1898, being advanced in numbers for meritorious services upon that occasion.

**ENTWISTLE**, **Joseph**, English clergyman: b. Manchester, England, 15 April 1767; d. Tadcaster, 6 Nov. 1841. In 1787 he was called into the Wesleyan ministry by John Wesley and spent 54 years of his life in preaching the Gospel. He was twice president of the British Conference and was connected with the Theological Institution at Hoxton 1833-38. His last years were spent at Tadcaster. Consult 'Memoir of Rev. Joseph Entwistle' by his son (1st ed. 1845, 5th ed. 1861).

**ENURESIS**. See URINE, INCONTINENCE OF.

**ENVELOPE**, a paper case, sealable by means of an adhesive flap or other means, and used for enclosing letters or other matter. It has not been established definitely by whom and where envelopes were invented, but they seem to have been used first in France, possibly as early as the middle of the 17th century, though in very limited quantities. They were not in general use in any country prior to 1839-40, when, after the passage of the penny postage bill, they became common in England. Until about 1845 nearly all letters in this country were folded so that an unwritten portion came on the outside, and the address was placed there, though even then there was a certain demand for envelopes, all of which, however, were made entirely by hand. Gradually the use of envelopes spread and by 1850 practically all letters were enclosed in them. The first maker of envelopes in New York is believed to have been a Mr. Pierson who, as early as 1843, made envelopes by hand in his store on

Fulton street. In 1846 he sold his business to an Englishman named Dangerfield who was soon succeeded, first by Jacob Berlin, and then by W. G. West. At that time only 2,000 or 3,000 could be made in a day, as machinery was not yet used. The blanks were cut out by means of a sheet of metal, placed on top of a pile of paper, around the edges of which a sharp knife was run. They were then folded and pasted by hand. Machines were invented in England, probably as early as 1840, though they were not patented until 1849, by Warren de la Rue and Edwin Hill, the latter a brother of Sir Rowland Hill (q.v.), the father of the penny post. These machines were one of the chief attractions of the Hyde Park Exposition, held in London in 1851. The first machine used in this country was a French model. It had been purchased in 1847 for \$600 by H. C. Berlin, son of Jacob Berlin, who had gone into the envelope business with his father's successor, W. G. West. This machine, however, was not very successful. The first patent for an envelope-folding machine was issued in the United States 23 Jan. 1849 to J. K. Park and C. S. Watson of New York, the second on 26 April 1853 to E. Coleman, Philadelphia. Neither of these was accompanied by commercial success. The third patent was issued to Dr. Russel L. Hawes, a physician of Worcester, Mass., in 1853. This machine was quite successful, but was used exclusively by the concern founded by its inventor, which, after many changes in ownership, is still in existence as the W. H. Hill Envelope Company, Division of the United States Envelope Company. Not until just before the outbreak of the Civil War was a machine patented and placed on the open market. The inventor was George H. Reay, and his machine was for many years one of the most successful. It gave a tremendous impetus to the envelope industry. At this period many others invented envelope machines or attachments to them none of which, however, could be purchased in the open market. From then on the development of envelope machinery made rapid strides. Improvements gradually provided for self-feeding, gumming, automatic counting, etc. The men chiefly responsible for these improvements were J. M. D. Keating, T. V. Waymouth, H. D. and D. W. Swift, J. G. Arnold, D. Whitcomb, and others. Many of these early inventors went into business for themselves and quite a number of these comparatively old concerns were included in the consolidation of the 10 leading envelope companies accomplished in August 1898, and thereafter known as the United States Envelope Company, Inc. Modern machines have been improved to a point where it is possible for one machine to turn out as many as 55,000 envelopes a day. The variety of envelopes, too, has rapidly increased. They are used now not only to enclose letters, but a great deal of printed matter and for many other purposes. Recent innovations are especially the so-called window-envelope, with a transparent front through which the address at the head of a letter can be read, saving thereby the separate addressing of the envelope; envelopes with special sealing devices, such as metal hooks and eyes, threads, etc.; and the envelope with a wire or thread attached to its inner edge,

facilitating its opening. Since 1853 the government supplies stamped envelopes, which are purchased in ever increasing quantities, the total issue to postmasters in 1916 amounting to 1,853,791,461 of a gross selling value of \$36,875,445. About two-thirds of these are issued with printed return cards in the upper left hand corner. Practically every government, having a postal service, issues stamped envelopes. The remarkable growth of the envelope industry can be seen from the following figures, based on 'The United States Census of Manufactures of 1914' (Washington 1917): In 1849, the first year for which figures are available, the total value of products in the envelope industry was \$45,000. In 1914 there were 90 establishments with 6,970 operatives, capitalized at \$15,830,000 and producing goods valued at \$18,481,000. These figures indicate increases during the 10-year period, 1904-14, of 25 per cent, 62 per cent, 110 per cent and 77 per cent, respectively. Envelope factories were located in 1914 in 15 States of the Union, especially in Massachusetts, Illinois, Ohio, New York, Connecticut, Pennsylvania, Missouri. Consult Logan, J., 'The Story of the Envelope' (in *The Red Envelope*, Hartford 1915-17); House of Representatives, Committee on United States Post Office and Post Roads, 'Stamped Envelopes' (Hearings during April 1910, Washington 1910).

**ENVER PASHA**, Turkish soldier and war minister: b. Constantinople about 1880. Of aristocratic descent, he was educated for the army and saw his first active service in Macedonia against the Serb and Bulgar komitadjis. He was one of the prime movers in the Young Turk revolution of 1908. Stationed at the time in Salonica, his activities were known at Constantinople. In a friendly letter he was invited to return to the capital and promised promotion. But Enver Bey—as he then was—knew better than to accept the invitation. He disguised himself as a peasant and fled to the mountains, traveling rapidly from place to place, spreading the doctrine of revolt and putting the final touches to the preparations. The speedy success of the revolution, the revival of the dormant constitution of 1876, and the subsequent fall of Abdul Hamid, raised Enver to the height of a popular national hero. He was "lionized" in Paris and London; at the latter place he was introduced to both houses of Parliament. Under the new régime he was sent as military attaché to Berlin, where he learnt German, studied the Prussian military organization, and became a close friend of the Kaiser. According to competent observers, the mighty emperor and the humble attaché had much in common, especially dreams of boundless ambition. Fired with admiration for all things German, Enver returned to Constantinople an ardent apostle of Teutonism and heartily threw himself into the work of assisting the German Generals von der Goltz and Liman von Sanders to build up the Turkish army. That army, however, failed of its purpose in the Tripolitan and Balkan wars, in both of which Enver played a prominent part. Of youthful, almost boyish, appearance, poetical imagination and undoubted courage, though entirely unscrupulous, he became the most picturesque figure in Turkish politics. Those who stood in his way he simply shot down. In Jan-

uary 1913 he shot the Commander-in-Chief, Hussein Nazim Pash, and two aides-de-camp who attempted to stop him from entering the council chamber. (Prince Yussuf-ed-din, the heir to the throne, was murdered in February 1916 by order of Enver Pasha). In January 1914 Enver was appointed Minister for War and created a pasha. At the beginning of the European War six months later, Turkey declared her neutrality. Although, apparently, most of the ministers opposed entering the War, they were overborne by Enver Pasha, who not only had the whole Turkish army at his back, but had also adopted the German view that Turkey's salvation was bound up with the success of German arms. Consult Buxton, C. R., 'Turkey in Revolution' (London 1909); 'Enver Pasha's Reign of Terror at Constantinople' (*Current Opinion*, September 1915); 'Enver Pasha' (*Current Opinion*, April 1916); Freeman, L. R., 'Enver Pasha: Turkish Patriot' (*Harper's Weekly* August 1915); 'The Calvary of a Nation,' (*Atlantic Monthly*, November 1916); 'Why Turkey Went In' (*Harper's Weekly*, 10 April 1915); 'The Turkish Atrocities in Armenia' (*Outlook*, 29 Sept. 1915). See TURKEY; WAR, EUROPEAN; TURKISH CAMPAIGN.

**ENVIRONMENT**, a modern scientific term applied to the modifying influences of an organism or surroundings. Neither plant nor animal can be understood as a rounded-off unity; the whole life or function is made up of action and reaction between the organism and its environment. Streams of matter and energy from without preserve the relative constancy of the organism, as of a special wave-crest in the sea; while changes in the streams have their corresponding changes within the organism. The plant or animal has obviously a strong unity of its own, but even that is in part due to ancestral welding under the hammers of the environment. It may seem, too, to vary of itself like a fountain in the air, but throughout all its rises and falls there blows the wind of the environment.

The influence of outside conditions has been recognized by most naturalists from the time of Hippocrates, and is taken for granted in our everyday speech and action. There is considerable difference of opinion, however, as to the importance and degree of this influence. Thus Buffon, Treviranus and Geoffroy Saint Hilaire regarded the surroundings as directly hammering changes on the organism; while to Erasmus Darwin and Lamarck internal changes arose as indirect functional results of new environment. Charles Darwin allowed a measure of truth in both these positions, but emphasized the independent action of the organism itself in the direction of natural selection. These three positions are still held, some emphasizing one, others another, the majority combining the three. See DARWINIAN THEORY; EVOLUTION; HEREDITY.

**ENVOI**, *ón-vwá'*, the last stanza of a ballad (q.v.).

**ENVOY**, originally *envoyé*, the French translation of the Latin word "ablegatus," a person deputed by a sovereign or government to negotiate a treaty, or transact other business of a diplomatic nature with a foreign ruler or government. In its general use we usually apply the word to a public minister sent on a special occasion or for one particular purpose; hence

an envoy is distinguished from an ambassador. Envoy extraordinary and minister plenipotentiary is a permanent resident abroad, usually in one of the less important countries officially representing his government, but of inferior rank to an ambassador. His ranking, next to ambassadors, dates back to the beginning of the 18th century, though the term was in use as early as the 17th century at which time envoys belonged to the second class of diplomatic agents together with agents, residents and *ablegati*. Consult Foster, J. W., 'The Practice of Diplomacy as Illustrated in the Foreign Relations of the United States' (Boston 1906); Garcia de la Vega, D., 'Guide Pratique des Agents Politiques, etc.' (Bruxelles 1873); Krauske, O., 'Entwicklung der Ständigen Diplomatie, etc.' (Leipzig 1885); Satow, Sir E., 'A Guide to Diplomatic Practice' (2 vols., London 1917).

**ENZINA**, Juan de la. See ENCINA, JUAN DEL.

**ENZINAS**, *ën-thé'na*, Francisco de (also known as DRYANDER), Spanish translator of the New Testament: b. Burgos 1520; d. 1553. He was educated at Louvain and at Wittenberg. During his stay in the latter place he resided at the house of Melanchthon. He translated the New Testament from the Greek in 1543 and presented a copy to Charles V. His heretical views caused his imprisonment at Brussels; he escaped after a year's confinement and made his way to Wittenberg. Crammer made Enzinas professor of Greek at Cambridge in 1548. Thereafter his life is obscure and according to some accounts he died at Strassburg in 1553 of the pestilence, according to others he was last heard of at Geneva in 1570. He wrote 'History of the State of the Netherlands and of the Religion of Spain' (1558, republished as 'Mémoires de Francisco de Enzinas' (3 vols., Brussels 1863). Consult Menéndez y Pelayo, 'Historia de los Heterodoxos españoles.'

**ENZIO**, king of Sardinia: b. about 1220; d. 14 March 1272. He was a natural son of Frederick II, the German Emperor, with whom he fought at Cortenuova against the Lombards in 1237. In 1238 he married Adelasia, and was made King of Torres and Gallura and later King of Sardinia. In 1241 while in command of the fleet Enzo inflicted a great defeat on the Genoese. In the years following he added renown to his name by his exploits in Lombardy. He laid siege to Parma in 1248 but was compelled to withdraw; he next besieged Colonna, took the castle of Arola in 1248, but on 26 May of that year he was made prisoner at Fossalta by troops of Bologna and sentenced to life imprisonment. Consult Blasius, 'König Enzo' (Breslau 1884) and Jordan, 'Les origines de la domination angevine en Italie' (Paris 1909).

**ENZOÛTIC**, *ën-zō-ōt'ik*, a disease which appears to have secured a permanent lodgement in the animals of a region. It is used of animals as the term *endemic* is used of diseases which affect man in certain localities.

**ENZYME** (Gr. 'leavened'), any of the unorganized ferments, such as diastase, cytase, trypsin, etc., which induce fermentative changes in organic substances. It was formerly thought that these 'unorganized' ferments might be essentially different in their action from the so-



called "organized" ferments, such as the yeasts, molds and bacteria; but it is now known that the fermentive action of the "organized" class is due chiefly, and perhaps wholly, to the enzymes that they secrete. The chemistry of the enzymes is very imperfectly understood. According to some authorities they act merely by catalysis, being capable of effecting the fermentive change of indefinite quantities of the substances upon which they act, without being themselves used up, nor exhausted in any way. According to other authorities, they are gradually destroyed by their own activity, so that a definite mass of any given enzyme can produce only a definite (though surprisingly large) amount of fermentive transformation. See FERMENTATION.

Chemical ferments, elaborated in the cells of plants and animals and capable of bringing about a peculiar series of biochemical reactions, which are produced without the intervention of physical factors or mineral substances. Under some conditions they have the properties of facilitating chemical interchanges between certain bodies without entering into the composition of the different products that result. These enzymes, or ferments, zymases, or diastases, as they are frequently called, play an important rôle in the digestive processes, as well as being of vital importance in the general life-history of nearly all plants. A knowledge of enzymes dates back to very remote periods. In the beginning of the 16th century observations on the phenomena of digestion called attention to this class of bodies; but it remained for Dubrunfaut and Pasteur to place the science of fermentation on a stable basis. Enzymes are for the most part soluble in water, being thrown out of solution by a large number of chemical substances, such as alcohol, tannic acid, etc. They usually lose their activity at a temperature above 100° F. Most of them decompose hydrogen peroxide and they act largely in proportion to their quantity. With reference to their chemical composition, it would appear that they belong to the proteid class. There is usually a large proportion of inorganic salts, particularly calcium phosphate, in their composition. A few, however, do not contain nitrogen. Although closely related to proteids, they do not give proteid color-reactions. As to their formation, it is considered by some that they are oxidation products of albuminoid substances, or zymogens. The transition of the zymogen into the ferment is termed zymogenesis. Destruction of enzymes is termed zymolysis. As to the manner of action of this interesting class of bodies, a vast variety of phenomena may be observed. They may bring about molecular changes either by hydration or by oxidation. They appear to occupy the position of intermediaries, as it were. Many theories are put forward in attempting to explain the action of enzymes; but as they present many analogies to living protoplasm, explanation of the phenomena of their activities is almost as difficult as to explain the phenomena of life. Attempts have been made to classify the various enzymes, but any classification must be of a transitory character, since knowledge concerning this group of bodies is increasing daily. The classification of the soluble ferments suggested by Effront is shown below.

Those enzymes secreted by plants and animals in the course of their digestive processes,

such as invertin, which breaks up cane-sugar into a mixture of glucose and fructose, diastase, which has an analogous action on starch, ptyalin, found in the saliva, which also acts on starch, pepsin and trypsin, which decompose proteids in the acid medium of the stomach and the alkaline medium of the intestines, respectively, are not difficult of isolation, while almost none of the intracellular enzymes, which perform a far more important function in the life of the animal or plant, have yet been isolated.

The enzymes have many applications in the arts. Consult Effront, 'Enzymes and Their Applications' (New York 1902); Greene, 'Soluble Ferments.'

**EOBANUS**, *Helius* or *Hessus* (Eoban Koch), German philosopher: b. probably at Halgehausen 1488; d. 1540. He wandered about to different places in which he taught and lectured like so many teachers of the period. He espoused the Reformation, participated in the 'Epistolæ Obscurorum Virorum,' and translated Ecclesiastes and the Psalms. Consult the life by Krause (Gotha 1879).

**EOBASILEUS**, the latest-known species of the *Uintathere* (q.v.) fossil in the Bridger Stage of the Middle Eocene in the western United States. It was an immense, rhinoceros-like animal with a remarkably long and narrow head, with very large, shovel-shaped nasal protuberances from the skull and long, backward-curved tusks in the male.

**EOCENE**, *é'ò-sèn*, a subdivision of geological time. Lyell in 1833 first used the term Eocene (dawn of the recent) for the earliest of his three subdivisions of the Tertiary. The term found favor quickly since early Tertiary life differed greatly from late Cretaceous. Toward the close of Cretaceous time, the sea receded from a large part of North America and by the end of Eocene time the continent had nearly its present form. The climate continued warm, Greenland and Alaska being temperate. Of Cretaceous animals the reptiles suffered most, the ichthyosaurs, dinosaurs and plesiosaurs passing away as well as many peculiar mollusks. Eocene fishes were mostly of modern character (teleosts), birds were more numerous and highly developed than in the Cretaceous Age; while mammals developed wonderfully. True carnivorous mammals appeared, as also the ancestors of the horse, rhinoceros, tapir, pig and the ruminants, besides bats, primitive camels and monkeys. A study of organic types indicates that Asia, North America and Europe were connected in Eocene time; and, by the Antarctic continent, South America and Australia; while South America was separated from North America, and Africa and southern Asia from Europe and northern Asia.

The Eocene rocks of the Atlantic border are nearly all loose sands and clays of marine origin and contain in New Jersey beds of greensand once of some economic importance as a source of phosphate of lime for agricultural use. The rocks of the Gulf border were partly laid down in fresh or brackish water and partly in salt water. They comprise shales, sandstones and limestones. In Florida are valuable deposits of phosphate rock, and in Texas are extensive beds of lignite, of workable size, but poor quality. The interior province formations,

mostly clays and sands, were laid down as alluvial fans and cones (q.v.), in brackish or fresh water lakes which stretched, though not contemporaneously, from Mexico to Alaska. The largest of these lakes covered eastern Utah and western Colorado, and must have been 450 miles long and 250 miles wide. In Utah are lignite deposits of some importance. In the Pacific border province the Lower Eocene stages are wanting and the epoch is represented by a single series, the Tejon shales and sandstones, partly marine and partly terrestrial, with workable deposits of lignite in California and Oregon. See CENOZOIC ERA; GEOLOGY; TERTIARY SYSTEM.

**EOHIPPIUS**, the earliest known progenitor of the horses, found fossil in the Lower Eocene (Uinta) formations of the West, four-toed and about the size of a house-cat. See HORSE.

**EOLIAN DEPOSITS**, accumulations of wind-blown material. In some regions, particularly in deserts, such deposits may be of considerable importance. Most conspicuous are sand dunes, which occupy large areas in many parts of the world. Sand dunes sometimes become buried and consolidated to form sandstones, often strongly cross-bedded. Loess, fine wind-blown dust, accumulates to great thickness in some regions. Important deposits are known along the Mississippi and Missouri rivers in the United States, but the most extensive loess beds known are in China. Buried loess deposits would ultimately form shales. Eolian limestones are rare, but are known in Bermuda, where great dunes have accumulated, composed of the ground-up fragments of shells from the beaches. These dunes are consolidated in places to form limestones. See DUNE; LOESS; ROCKS.

**EOLITH**, one of the rudely chipped pebbles, regarded as a relic of the earliest dawn of human industry. The adjective "Eolithic" is sometimes used to designate the period of human history preceding the paleolithic stage of culture. See STONE AGE.

**EOLITHIC**. See PALEOLITHIC PERIOD.

**EON**, *ἄων*, or **EUDO DE STELLA**, also **EON DE L'ETOILE**, a religious fanatic of the 12th century, born in Brittany. He claimed to be the final judge of mankind and derives his name from the pronoun *eum*, in the formula "per eum qui venturus est iudicare vivos et mortuos." He was opposed to the hierarchy and sent forth his followers to plunder ecclesiastical property. He showed the inconsistency of his opposition to a hierarchy by putting himself at the head of a church and ordaining bishops and priests. The Legate Alberic and Hugh, archbishop of Rouen, were his principal opponents. He was captured in 1148, was tried at Rheims and, being considered insane, escaped execution. However, he was kept in prison for the remainder of his life; numbers of his followers perished at the stake and his sect soon disappeared. Consult Döllinger, 'Beiträge zur Sektengeschichte des Mittelalters' (Vol. I, Munich 1890), and Lea, H. C., 'History of the Inquisition of the Middle Ages' (New York 1888, and subsequent editions).

**EON DE BEAUMONT**, *ἄων δὲ βῆ-μόν*, Charles Geneviève Louis Auguste André Timothée d' (called till 1777, CHEVALIER D'EON),

French writer, military officer, diplomatist and publicist: b. Tonnerre, 5 Oct. 1728; d. London, 21 May 1810. His brilliant qualities enabled him to act a conspicuous part in the world, but he gained a greater notoriety by the mystery long kept up in regard to his sex. In 1755, by some other accounts in 1757, he was sent as envoy on a difficult mission, to the Russian court. Here he gained the favor of the Empress Elizabeth, and for about five years was the medium of a secret correspondence between her and the King of France. In 1762 he went to London as secretary of a special legation, under the Duke de Nivernais, sent there for the purpose of arranging peace between France and England. In April 1763 he was made French Resident Minister and chargé d'affaires. From then on, though soon officially superseded in his diplomatic office, he lived for years in London as a kind of informal representative of his sovereign. In 1777 he returned to France, but Louis XVI, for what reason has never been satisfactorily explained, imposed on him the obligation of assuming female attire and he now styled himself La Chevalière d'Eon. Even before this, however, doubts and discussions as to his real sex had arisen. He returned to England in 1785. After the French Revolution broke out, he styled himself Citoyenne Geneviève Déon. He now attempted to support himself by giving lessons in fencing (still dressed as a woman), but was not very successful and depended for subsistence mainly on his friends. He was a voluminous writer and his works appeared in 1775 under the title 'Loisirs du Chevalier D'Eon' (13 vols., London). He also wrote the memoirs of his life, covering especially the years of his residence in England, 1762-77. They have never been published; the manuscript is in the archives of the French Ministry of Foreign Affairs in Versailles. Consult, Broglie, J. V. A. de, 'Le Secret du Roi' (2 vols., Paris 1878; translated into English as 'The King's Secret' London 1879); Christie, R. C., 'Selected Essays and Papers' (London 1902); Gaillardet, F., 'Mémoires sur la Chevalière d'Eon' (Paris 1866); Ross, O. C. D., 'The Chevalier d'Eon and Peter the Great's Will' (in *Gentleman's Magazine*, n. s., Vol. XVIII, p. 159, London 1877); Telfer, J. B., 'The Strange Career of the Chevalier d'Eon de Beaumont' (London 1885); Vandal, A., 'Louis XVI et Elizabeth de Russie' (Paris 1882); Vizetelly, E. A., 'The True Story of the Chevalier D'Eon, etc.' (London 1895),

**EOS**, *ἔως*. See AURORA.

**EOSCORPIUS**, a fossil scorpion, known by its slender form, hand and pincers. It included about four separate species and abounded in the Carboniferous period. Many fine specimens have been uncovered at Mazon Creek, Ill. See SCORPION.

**EOSIN**. See COAL-TAR PRODUCTS.

**EOSINOPHILES**, *ἔ-δ-σίν'δ-φίλ*, one of the types of leucocytes or white blood-cells found in the circulating blood and characterized by its specific reactions to acid stains, such as eosine, whence its name—"a lover of eosine." Eosinophiles are present in the proportion of one-half to 2 per cent of the white blood-cells. Their increase above 2 per cent is termed eosinophilia, and it has an important relationship to some forms of parasitism.

**EOSINOPHILIA**, a condition in which there is an excess of eosinophile white blood-cells in the circulating blood. The exact causes of eosinophilia are not thoroughly understood. But it seems to be an almost constant accompaniment of certain diseases, notably of infection by intestinal parasites. So it is in trichiniasis, in anchylostomiasis and in infection by the ordinary tapeworm. Consult Ewing, 'Pathology of Blood' (1902).

**EOSTRA**, the Teutonic goddess of spring. The festival in her honor is believed to have given its name to our Easter.

**EOTHEN**, Alexander William Kinglake, later known as the historian of the Crimean War, made about 1835, three years after his graduation from Cambridge, a tour through Turkey, Egypt and the Holy Land. In 1844 after he had twice rewritten his manuscript he published a narrative of his Eastern experience under the title 'Eothen,' a Greek word signifying "from the early dawn" or "from the East." In an interesting preface he explains that he has deliberately avoided the virtues of the ordinary book of travel. What he has sought to impart is not statistical and geographical information but the tang and color and thrill of his own personal impressions amid those alien scenes and peoples which he discovered when he slipped out at the back door of Europe. As Kinglake's impressions were extraordinarily fresh, vivid and intense, and as his style corresponded to his impressions, he added to the golden treasury of travel literature an enchanting little volume which takes its place with 'Child Harold's Pilgrimage,' 'The Bible in Spain,' and 'Travels with a Donkey.' In reading books of this sort one's interest passes back and forth between the traveler and the lands through which he travels. Kinglake as he presents himself is the typical, self-contained, independent, resolute young English gentleman, concealing his occasional moments of poetical rapture beneath an imperturbable exterior and smiling inwardly to perceive how his mere presence and bearing extort from Turk and Bedouin the deference due to a natural lord of creation—a modest incarnation, in short, of that spirit which has made it impossible for the sun to set on British soil. The most amusing illustration of this English spirit is to be found in the 29th chapter, in which Kinglake relates how he and a Russian officer forced a landing at Satalieh in defiance of the quarantine officers, marched through the streets to the residence of the Pasha, entered his audience chamber, seated themselves on the divan at his side and bullied him through an interpreter into open-armed hospitality. Another wonderful chapter, 'Cairo and the Plague,' depends partly for its effect upon the stunning contrast between the wailing pestilence-stricken city and the nonchalant Englishman going about his business and his pleasure undeterred by the universal terror of contagion. Superb, too, as a representation of the traditional English reserve, is his account of his meeting in the desert with another solitary Englishman traveling westward from India, whom he would have passed with a silent nod but for the friendly interposition of their respective camels. The passages in 'Eothen,' however, which are unforgettable

and which raise the terse, brilliant, narrative almost to the level of poetry, are those commemorating the not infrequent occasions when the magic of the East broke through the traveler's guard and laid its spell upon him in some lonely bivouac by the Dead Sea, or in the Sanctuary of Nazareth, or on a dromedary's back in some sun-smitten wilderness of sand, or in a curious throng of dark-eyed Jewish girls, or when the sharp vision of an abandoned English garden flashed into memory and mingled with the splash of fountains and the fragrance of Eastern roses in some old garden of Damascus. Consult Tuckwell, 'A. W. Kinglake' (1902).

STUART P. SHERMAN.

**EÖTVÖS**, et'vësh, Joseph, BARON VON, Hungarian statesman and author: b. Ofen, 13 Sept. 1813; d. Pesth, 3 Feb. 1871. He was educated by private tutors, especially the well-known Hungarian patriot and liberal Pruzsinsky, who gained a powerful mental influence over him and was primarily responsible for the liberal ideas and ideals which Eötvös displayed later in life. He completed his studies in philosophy and law at the University of Pesth in 1831. Even before leaving the university he produced three plays—'Kritikusok' ('Házassulók') and 'Boszu'—the last a tragedy, all of which were well received. From 1832-37 he traveled extensively in Europe and occupied a number of minor governmental offices. After 1838 he devoted himself exclusively to literature and politics, joining the Young-Hungarian Reform party. In the same year he published an important work on the reform of prisons (Pesth 1838); he became a friend of Kossuth and distinguished himself as a journalist and as a speaker in the Diet. A collection of his early political writings was published in Leipzig in 1846. His literary work of this period resulted in a succession of novels giving vivid pictures of Hungarian life during his own times and in more remote epochs: 'The Carthusian' (Pesth 1838-41); 'A Falu Jegyzője' (Pesth 1844-46; translated into English as 'The Village Notary' by O. Wenckstern, New York 1850); 'Hungary in 1514' (3 vols., Pesth 1847-48). After the March revolution of 1848 he became Minister of Public Instruction under Batthany, but the September revolution of the same year made him lose hope in the cause of liberalism in his country and he retired to Munich, remaining in voluntary exile for three years. During this period he published several works, among which was 'The Influence of the Ruling Ideas of the 19th Century on the State' (2 vols., Pesth 1851-54), which is considered his most important work. About the middle of 1851 he again returned to Hungary and was made vice-president of the Hungarian Academy in 1856 and president in 1866. After his return he was a staunch supporter of Deák (q.v.) and of his efforts to arrange the famous Austro-Hungarian Composition (Ausgleich) of 1867. In that year he again became Minister of Public Instruction in the Andrássy cabinet. From then on until his death all his energies were devoted with considerable success to the improvement and liberalization of the Hungarian school system. In 1879 a bronze statue by Huszár was erected in his memory at Pesth. A collection of his writings was published in Pesth in 14 volumes

(1870), and still another in 17 volumes (1891). His political speeches were collected in two volumes in 1875 and 1886. Consult Berzeviczy, A. v., 'Baron Josef Eötvös als Kulturpolitiker' (in *Ungarische Rundschau*, Vol. III, p. 78, Munich 1914); Ferenczi, Z., 'Baron Josef Eötvös' (Budapest 1903); Ringwald, W., 'Beiträge zu einer Kritischen Würdigung der Staatslehre des Barons Josef von Eötvös' (Zürich 1908).

**EÖTVÖS, Roland**, Hungarian scientist and statesman: b. Budapest, 27 July 1848. He is a son of Joseph Eötvös (q.v.). He studied at Königsberg and Heidelberg, receiving an appointment as lecturer at Budapest 1871 and as professor of experimental physics there 1875, being made a member of the Hungarian Academy of Sciences 1873, and becoming its president in 1893. Much of his attention has been given to the problems of gravitation and capillary attraction. He was made a life member of the Hungarian House of Magnates and was Minister of Public Worship and Education 1894-95.

**EOZOIC** (ē-ō-zō'ik) **ERA** (dawn of life). one of the early names applied to the Geologic Pre-Cambrian or Algonkian period, during which life first appeared on the earth. The eozoic rocks, though often showing traces of organic origin, have in general been greatly metamorphosed and contain few, if any, fossils. Stratigraphically they are separated from the Archæan (or Azoic) rocks below and the Cambrian (or earliest Palæozoic) rocks above by unconformities. See ALGONKIAN SYSTEM; GEOLOGY; HURONIAN SERIES; KEWEENAWAN SERIES.

**EOZOÛN**, ē-ō-zō'ōn. Sir J. W. Dawson (q.v.) in 1864 described certain curious aggregates of calcite and serpentine in the Laurentian limestone of the lower Saint Lawrence Valley as the remains of a foraminiferan which he called Eozoön Canadense. The so-called fossil was thought to represent the earliest known form of life on the globe. The evidence of organic origin is, however, not conclusive. Similar forms have been found in Bavaria. Moebius, who investigated Eozoön thoroughly, concluded that the serpentine in the calcite had infiltrated along a very regular system of fine fissure and most geologists now believe that Eozoön is of inorganic origin. An extensive literature has sprung up as a result of this discussion. A list of most of the important papers, almost all published in scientific journals of Europe and this country may be found in the bibliography of Sir J. W. Dawson, attached to a memoir of his life by F. D. Adams and published in the Bulletin of the Geological Society of America (Vol. II, New York 1899). Consult Dawson, Sir J. W., 'The Dawn of Life' (London 1875); 'Review of the Evidence for the Animal Nature of Eozoön Canadense' (in McGill University Paper, Department of Geology, Nos. 1-2, Montreal 1896); Hauer, M., 'Das Eozoön Canadense' (2 vols., Leipzig 1885).

**EPACRIDACEÆ**, ēp-a-kri-dā'sē-ē, a small order of heath-like shrubs or small trees, usually reckoned as the Australian sub-order of *Ericaceæ*, from which they are chiefly distinguished by the epipetalous stamens destitute of the peculiar specializations of anther dehiscence or appendages. The flowers are red, white or

purple, generally in leafy spikes. Many species are cultivated in greenhouses along with the heaths proper. Among the most attractive of these is *E. grandiflora*, which has blossoms nearly an inch in length, of a brilliant reddish purple at the base and pure white at the apex. A few species produce edible berries resembling the American huckleberry, and which are known as Australian cranberries.

**EPACTS** (Gr. "additions"), in ecclesiastical chronology, a set of 19 numbers used for fixing the date of Easter and other Church festivals, by indicating the age of the moon at the beginning of each civil year in the lunar cycle. At the reformation of the calendar in 1582 it was found that the Golden Numbers could no longer by themselves serve the purpose of adjusting the double reckoning by lunations and by the tropical or true year; and thus, instead of adopting the more rational computation, the Roman Church devised the artificial and involved method of epacts. The main point to determine is the age of the moon (in entire days) at the beginning of each civil year, or the number of days between the end of the ecclesiastical year in December and the first January succeeding. Thus, subtracting 354 days (12 lunations) from 365, we should have 11 days for the first annual epact, then 22 for the year following, then 3, 14, 25, 6, 17, 28, 9, 20, 1, 12, 23, 4, 15, 26, 7, 18 and 29; the series of 19 numbers being obtained in succession by adding 11, and when the sum exceeds 30, subtracting that number. This illustration, however, is simpler than any actual case, by reason of the leap-years, which require 12 to be added for the following epact, and of the fact that no lunation is exactly 30 days long. When the lunar cycle of 19 years is completed, the epacts recur again in the same order. In the Anglican reckoning, as distinguished from the Roman, it is noteworthy that the Gregorian epact for any year is the same as the Julian epact for the year preceding, owing to the coincidence that 11, the number of days lost on the Julian account before the English Parliament adopted the reformed calendar (q.v.), is also the number of days between the lunar and the solar years. The epact determines by subtraction the date of the first new moon in January; then by adding 29 and 30 alternately the successive new moons throughout the year are assigned to their respective dates. Consult Clavius, C., 'Romani Calendarii a Gregorio XIII P. M. Restituti Explicatio etc.' (Rome 1603); Butcher, J. G., and Butcher, S. H., editors, 'The Ecclesiastical Calendar: Its Theory and Construction' (Dublin 1877); De Morgan, A., 'The Book of Almanacs' (London 1871); Seabury, S., 'The Theory and Use of the Church Calendar in the Measurement and Distribution of Time' (New York 1872); Kennedy, Thomas, 'Epacts' (in 'Catholic Encyclopedia,' Vol. V, p. 480, New York 1909).

**EPAMINONDAS**, ē-pām'ōn-ōn'dās, Theban general and statesman: b. about 418 B.C.; d. Mantinea, Arcadia, Greece, 362 B.C. He was distinguished for the friendship existing between him and Pelopidas, whose life he had saved in 385 at Mantinea. He was sent to Sparta 371 B.C. to represent Thebes in negotiating a peace with the Athenian envoys. As the Spartans refused to recognize Thebes as the

representative of Bœotia, the Thebans were excluded from the peace. Cleombrotus was sent by the Spartans to invade Bœotia, but was defeated at Leuctra (371 B.C.), chiefly through the tactics of Epaminondas. Two years after Epaminondas and Pelopidas were made Bœotarchs. They detached several nations from the alliance of Lacedæmon, and delivered the Messenians, whose capital they rebuilt. Epaminondas then marched with his army to Sparta; but this city was so bravely and skilfully defended by Agesilaus that the Theban hero retreated. An accusation was brought against him on his arrival in Thebes, because he and Pelopidas had kept the Bœotarchate beyond the legal time; the accusation was literally true, but the infringement of the law was justified by his services, and after having pleaded his own cause, he was acquitted. In 368 he compelled Sicyon and Pellene to relinquish the Lacedæmonian alliance, and in the same year served in a Theban army sent into Thessaly to rescue Pelopidas, who was kept a prisoner at Pheræ. In the following year he commanded an expedition with the same object which was successful. In 362 he was compelled to make head against a formidable coalition of states, including Athens and Sparta. His tactics were never more brilliant and successful than in this campaign, but in the battle of Mantinea he was killed at the moment of victory. Consult Colcroft, J. W., 'Epaminondas of Thebes' (in *Dublin University Magazine*, Vol. XL, p. 34, Dublin 1852); Cornelius Nepos, 'Vita Epaminondæ'; Pomtow, L., 'Das Leben des Epaminondas' (Berlin 1870); North, Sir T., ed. and trans., 'The Lives of Epaminondas, Philip of Macedonia, etc.' (in 'Plutarch's Lives of the Noble Grecians and Romans,' London 1656); Yonge, C. M., 'A Book of Worthies' (New York 1882).

**EPAPHOS**, the son of Zeus and Io, who, according to Ovid, caused Phaëton's destruction by denying his divine descent. Epaphos, according to Greek mythology, became the ancestor of the Egyptian race and the first lord of their country whither his mother had fled before the jealous wrath of Hera and where he had been born. There are comparatively few references to him in the Greek writers; only Pindar, Æschylus, Euripides, Herodotus, Ovid and a few less important writers of later date mention him. Herodotus claims that his name was the Greek equivalent to the Egyptian deity Apis. Consult Berens, E. M., 'A Handbook of Mythology' (New York, n. d.); Gruppe, O., 'Griechische Mythologie und Religionsgeschichte' (in 'Handbuch der Klassischen Altertums wissenschaften, etc.,' Vol. VII, Munich 1897-1903); Linforth, I. M., 'Epaphos and the Egyptian Apis' (in *University of California Publications in Classical Philology*, Vol. II, No. 5, Berkeley 1910).

**EPARCHY** (*ἐπαρχία*), originally the name of one of the divisions of the Roman Empire, being a subdivision of a diocese. Both of these terms were adopted by the Church. Ecclesiastical eparchies were under a metropolitan to whom the first Council of Nicæa (325) gave the power to appoint the other bishops in his eparchy. Later this term was applied to mean the diocese of any bishop. It is now in common use only in the Russian

Church, where it still applies to all subdivisions of the Church corresponding to the western diocese. There were, before the Russian Revolution of 1917, 86 eparchies of which three were administered by metropolitans (Kiev, Moscow and Petrograd), 14 by archbishops and the rest by bishops.

**EPAULEMENT**, *é-pâl'mënt*, in fortification, a term originally employed to denote a mound of earth, raised to protect a body of troops at the extremity of their line; or a screen or rampart erected, as a sort of shoulder, to defend the flank of a battery from enfilading fire, which would dismount its guns. In modern artillery, the word is applied to the whole mass of earth, stone or fascines raised to protect a battery both in front and at the flanks. It is also used of the breastwork set up to shelter reserve artillery. See **FORTIFICATIONS**.

**EPAULET**, *épâ-lêt*, an ornamental badge consisting of a fringe hanging over the shoulder, worn in the English army up to 1855, and still worn in the English navy by all ranks above lieutenant. Epaulets were not partially discarded by the United States army until 1872, when none but general officers continued to wear them. In the United States navy the epaulet is worn by all officers above the rank of ensign. The French private soldiers wear epaulets of worsted.

**EPÉE**, *â-pâ'*, Charles Michel, Abbé de l', French instructor of the deaf and dumb: b. Versailles, France, 25 Nov. 1712; d. Paris, 23 Dec. 1789. Taking orders, he became a preacher and canon at Troyes, but later lived in retirement in Paris. In 1765 he first began to occupy himself with the education of two deaf and dumb sisters; and, as he asserted, without any previous knowledge of Pereira's efforts in the cause, invented a language of signs, by which persons thus afflicted might be enabled to hold intercourse with their fellow-creatures. He determined to devote his life to the subject. At his own expense he founded an institution for the deaf and dumb, which was first publicly examined in 1771, and from 1778 received an annual subsidy. It was not, however, converted into a public institution till two years after his death. He published 'Institution des Sourds et Muets, etc.' (Paris 1774); 'Instruction des Sourds et Muets par la Voie des Signes Methodiques' (Paris 1776); 'La Véritable Manière d'instruire les Sourds et Muets' (Paris 1784). Consult Arnold, Thomas, 'Aures Surdis. The Education of the Deaf and Dumb' (London 1872); Arrowsmith, J. P., 'The Art of Instructing the Infant Deaf and Dumb, etc.' (London 1819); Berthier, F., 'L'Abbé de l'Epée, sa Vie, etc.' (Paris 1852); Bouilly, J. N., 'The Deaf and Dumb; or, the Abbé de l'Epée. An Historical Play in Five Acts' (Paris 1800; London 1801).

**EPEIRA**, *è-pi'ra*, a genus of spiders, typical of the family of *Epeiridæ*, comprising some of the largest and best-known spiders, those building orb-webs. They occur in all parts of the world, and are usually handsomely marked. See **ORB-WEAVER**; **SPIDER**.

**EPEIROGENIC MOVEMENTS**. These are such geological movements as have to do with the uplift and depression of continents and oceanic basins, as distinguished from oro-

genic movements, which form mountain ranges. Their causes are only imperfectly understood. Among the factors which are thought to have played a part in inducing them are the expansion of strata in which the escape of heat has been blanketed by superincumbent deposits, the weight of these superincumbent deposits, the wrinkling of the earth's crust due to cooling and the tidal effect of the moon on the earth's lithosphere. Epirogenic movements are usually measured from sea-level, but it is highly probable that they are all in the strictest sense movements of depression, as there is strong evidence that the radius of the earth's crust is steadily diminishing. See EARTH; GEOLOGY.

**EPENCEPHALON**, a term used to designate that part of the embryonic brain from which the cerebellum and pons Varolii are formed. In the fully developed brain the term is used for that part containing the cerebellum, pons Varolii and the medulla oblongata. See BRAIN.

**EPERÏES**, ä-pär'yès (Slovak *Pressova*), Hungary, an old town on the Tarca, 190 miles northeast of Budapest by rail. The city was destroyed by fire in 1887. It is the seat of a Greek Catholic bishop, and has a Lutheran college. It manufactures earthen-ware, linens and woolens, and has some trade in corn and Tokay wine; in the vicinity are the Sovar saltworks. The Reformed Church made great headway here and the city played a considerable part in the religious wars of the 16th and 17th century. It is celebrated as the scene of the "butchery of Eperies," when the Austrian general Caraffa in 1687 instituted a series of Protestant persecutions and martyrdoms. Pop. 16,323.

**EPERNAY**, ä-pär-nä, France, in the department of Marne, in the midst of a rich vine-growing district, 19 miles northwest of Chalons. The earthen-ware called terre de Champagne is made in Épernay. It is an entrepot for Champagne wines, which are kept in vaults in the chalk rock on which the town is built. There are large railway workshops. Pop. 21,811.

**ÉPERNON**, dä-pär-nôn', Jean Louis de Nogaret, Duc d', French courtier: b. 1554; d. 1642. About 1573 he became a partisan of Henry III, whose fortunes he followed and whose chief favorite he became. In return the king enriched him, made him Duke of Epèron in 1581, and admiral of France. He was appointed governor of Normandy in 1587, but through the influence of the Catholic League he was exiled to Loches in 1588. Henry IV made him governor of Limousin in 1596 and he was transferred to Guienne in 1622. In the early period of his ascendancy Epèron was a defender of absolute monarchy, but later he urged the independence of the nobility. His opposition to the policies of Cardinal Richelieu caused the latter to banish him to Loches in 1641. Consult the life by Montbrison (Paris 1874).

**EPERVIER**, The. See PEACOCK AND EPERVIER, BATTLE OF.

**EPHAH**, e'fa, a dry measure of capacity among the ancient Hebrews, corresponding with the liquid measure bath. The ephah contained about 37 litres, equal to about 10 gallons of the United States or 8 gallons British. There were, however, two measures called ephah, of

which the above estimate applies to the smaller, and this contained about one-tenth less than the other. The ephah had 18 cabs or 72 logs. Consult Nicholson, E., 'Men and Measures' (London 1912).

**EPHARMONY**. See ECOLOGY.

**EPHEDRA**, èf'è-drà, a genus of shrubs used for decorative purposes in landscape gardening. In general appearance they resemble the horsetails. The flowers are small and inconspicuous. The species occur in all parts of the world, but are not hardy and need protection from frosts. They flourish best in dry or rocky soils and are easily propagated. Their fruit is said to be mucilaginous, eatable, sub-acid and slightly pungent. The branches and flowers of the Asiatic species were formerly sold as styptics.

**EPHEMERA**, e-fem'e-rä, the typical genus of the insect family *Ephemeridæ* (q.v.).

**EPHEMERIDÆ**, èf-è-mèr'i-dè, a family of neuropterous insects characterized by the slenderness of their bodies; the delicacy of their wings, which are erect and unequal, the anterior being much the larger; the rudimentary condition of the mouth, and the termination of the 10-jointed abdomen in 3-jointed filiform appendages. The adult May-flies, or day-flies, as they are called, emerge from the chrysalis on the banks of the running streams in which the eggs are hatched, and, appearing usually toward sunset, when they throng about street-lamps, lighthouses (where sometimes they obscure the light) and the screens of lighted windows, are no less remarkable for their great activity than for their enormous numbers, and the brief period of their existence. The eggs, which are shed in a mass, drop into the water. The larvæ have elongated depressed bodies; setose antennæ, and long caudal filaments; and lamellar or tufted gills, symmetrically disposed on either side of the abdomen. They remain in the water for a year or two before undergoing further change, lying beneath stones, and leading a pre-daceous life, for which their strong jaws fit them. The rudiments of wings mark the commencement of the nymph stage, at the close of which they crawl out of the water and cast the nymph integument. Their sexual immaturity prior to the second molt has led to their being named, at this stage, subimagos or pseudimagos. The larvæ, which are very similar throughout the family, are largely used as bait. There are many species in various parts of the world, divided into various genera. *Ephemera* and *Cenis* have three caudal filaments; *Palingenia* and *Cloë* only two, but the larvæ have three. The posterior wings are absent in *Cloë* and *Cenis*. Consult books mentioned under INSECTS.

**EPHEMERIS**, an astronomical almanac. The plural Ephemerides is applied to tables showing the places where the planets and heavenly bodies are found at noon of every day. It is from these tables that eclipses, conjunctions, etc., of the planets are determined. An especially exhaustive and very carefully compiled bibliography, covering some 280 columns, is to be found under the heading 'Ephemerides' in the 'Catalogue of Printed Books,' published by the British Museum (London 1887, 1902, etc.). Consult Newcomb, S., 'Sidelights on Astronomy' (New York 1906). See ALMANAC

**EPHESIACA, or EPHESIAN TALES,** a romance in Greek from the pen of Xenophon of Ephesus. It is occupied with the loves of Abrocomas and Anthia, and is the primary source of the story of Romeo and Juliet.

**EPHESIANS, Epistle to the.** Addressed to "the saints that are at [Ephesus]" by Paul the Apostle when a Roman prisoner (i, 1; iii, 1; iv, 1; vi, 20), linked in time and place of composition with "Colossians" and "Philemon" by the mention of the same bearers, Tychicus "of Asia" (Acts xx, 4; Eph. vi, 20; Col. iv, 7) and Onesimus of Colossæ (Col. iv, 9; Philem. v, 12) and the same five persons sending salutations (Col. iv, 10-14; Philem. 23-24). As the words "at Ephesus" are wanting in our oldest MSS. (Sinaiticus and Vaticanus), a fact known to Origen (A.D. 186-254), Basil of Cæsarea (329-379), and probably to Marcion (150?) who named the epistle assent to another city of Asia, Laodicea, the original may have borne the address: "to the saints that are in Asia" (1 Cor. xvi, 19; Acts xix, 10), like "the saints that are in the whole of Achaia" (2 Cor. i, 1) so as to include the province as well as the capital. That "the epistle" which Paul in Col. iv, 16 asks to have brought "from Laodicea" for public reading was our "Ephesians" is a common and plausible conjecture. Its suitability in form and contents to serve thus as a circular letter has been recognized since the time of Beza (1589) and Archbishop Ussher (1673). Personal greetings and messages, like those in Col. iv, 10-17 (to be given orally, Eph. vi, 21-22), and controversial matter like Col. ii, 8-23, would necessarily be omitted. There would remain, however, a large residue of apostolic teachings, having vital and common significance to all "the churches of Asia."

**Origin and Content.**—Answering to their simultaneous origin, the phenomenal parallelism between Colossians and Ephesians in thought and diction presents a psychological and literary problem of exceptional interest, as no fewer than 78 of the 155 verses of the latter epistle contain phraseology which occurs in the former. The prevailing penchant of the 19th century for literary dissection, however, has failed to produce, even with the critical acumen of a Holtzmann, anything better than a complicated and preposterously artificial theory of secondary imitation and compilation. Here is no patched garment, but a seamless robe. In its profundity, sublimity, spiritual and ethical intuition and in structural symmetry, Coleridge's eulogium is well-nigh justified: "the divinest composition of man." In the background of both epistles there looms the august person of the Cosmic Christ (Col. i, 14-16; Eph. i, 22-23); supreme in the heavenly realm (Col. i, 16; Eph. i, 10-16); vitally and creatively present everywhere in his Church (Col. i, 6, 18-19, 27; Eph. i, 22-23); the living bond of union between Jew and Gentile (Col. i, 20; Eph. i, 10; ii, 15f); the perennial source of transcendent spiritual knowledge (Col. i, 9; Eph. i, 17), and ethical vigor (Col. iii, 12-13; Eph. iv, 2, 32). If the mood of Colossians is that of discussion, that of Ephesians is meditation. Actual residence in Rome (Phil. iv, 22) the ruling capital of "all the world" (Col. i, 6), sets "the kingdom of Christ and God" (Eph. v, 5) in age-long and world-wide per-

spective. Calm meditation upon the cosmic implications of the Gospel message, unvexed by controversial stress, leaves its impress upon the vocabulary and style of one who could speak of having been "caught up into Paradise" (2 Cor. xii, 4). Thus in i, 3-iii, 21 the greater elaboration of the conventional epistolary divisions of Address, Thanksgiving and Prayer, foreshadowed in passages like Rom. i, 1-15, flows forth in full luxuriance, and in like manner the effort (manifest in Col. ii, 8-23) to gain greater fulness of expression by means of lengthy sentences built up of many subordinate clauses, and the employment of an ampler vocabulary, has freer scope. The resulting superficial aspect of aimless discursiveness is apparent rather than real; for faith and love, the dominant elements of all of Paul's Christological teaching, form the obvious warp and woof throughout.

**Theme.**—The subject of the epistle is: The Reincarnation of the Cosmic Christ in his Church through faith (chs. i-iii) and through love (chs. iv-vi). Following the characteristic opening salutation of "grace" and "peace" from God and Christ (i, 1-2) an elaborate Doxology (in place of the usual Thanksgiving) develops God's pre-mundane plan: the gift to Jewish and Gentile believers through Christ of salvation, spiritual wisdom, faith and love (i, 3-16a). The Prayer, which forms the subject of the remainder of the first three chapters, is for the revelation to the readers' faith of God's redemptive purpose for the whole human race (i, 16b-iii, 21). After the substance of the prayer is briefly introduced in i, 16-19, three facts are developed as stimulating to faith: God's power already exhibited in the Head of the Church by his resurrection and enthronement and reproduced in the spiritual life of the members of his body, the Church (i, 21-ii, 10); in the spiritual union in his Church of the two mutually hostile divisions of the human race (ii, 11-22), and in the revelations of divine power and grace vouchsafed to the apostle in his Gentile ministry (iii, 1-13). The way is thus prepared for the triumphant *da capo* repetition in iii, 14-19, with full organ tones, of the initial *motif* of i, 16-19. The exquisite summarizing cadence (iii, 20-21) in the form of a doxology, like the opening one in i, 3-14, is an appeal to faith such as appears in the whole underlying motive of i-iii. The complementary theme of chs. iv-vi is love, the organic principle of the life of God and Christ in his Church (iv, 1-16) and a regenerating and unifying force in all of the believer's social and domestic relations (iv, 17-6, 9). The concluding section (vi, 10-24) strikes once more the dominant notes of "faith" and "love." The life of faith in Christ and God is shown to be the Church's sole defense against superhuman spiritual foes (vi, 10-18). The closing personal references, after bespeaking such a loving interest in the prayers of the readers as the writer has for them, and repeating the initial salutation (i, 2) of "grace" and "peace" from God and Christ, end on the two high notes of "faith" and "love," and with characteristic Pauline stress on the "greater" (1 Cor. xiii, 13) of these.

**Bibliography.**—Discussions of the problems of authorship, vocabulary, style and re-

lation to Colossians may be found in New Testament Introductions: T. Zahn (Eng. trans. 1909); J. Moffatt (1901); B. Weiss (1897); H. J. Holtzmann (1892); A. Juelicher (1904); A. S. Peake (1910); F. J. A. Hort (1895) and detailed exegesis in the commentaries of C. J. Ellicott (4th ed., 1868); H. A. W. Meyer (Eng. trans., 1880); J. A. Robinson (1904); H. von Soden (Handcommentar, 2d ed., 1893); E. Haupt (8th ed., 1902).

MARCUS D. BUELL,  
*Professor of New Testament Greek and Exegesis, Boston University School of Theology.*

**EPHESUS**, ἐφέ-σῦς, Asia Minor, a Greek city of Lydia; one of the 12 Ionian cities; near the mouth of the river Caystrus, now called Kutshuk Mendre. Ephesus is now represented by the village of Ayasoluk, about 36 miles from Smyrna, on the railroad to Aidin. After belonging to the Ionians, it fell successively under the dominion of the Lydian and Persian kings. Its importance as a commercial city dates chiefly from the time of Alexander the Great, and it was the starting point of one of the great trade routes into Asia Minor. The apostle Paul lived for two years at Ephesus and established a Christian Church there, to which he addressed one of his epistles. Timothy succeeded Saint Paul, and Saint John is said to have had charge of the Church after Timothy, and to have died at Ephesus. Its bishop was the first of the seven to whom the Apocalypse was addressed. It was long famous for its temple of Artemis (Diana), called Artemision, reckoned one of the seven wonders of the world. The temple was of the Ionic order, and was adorned with many pillars, each 60 feet high, and with numerous statues and paintings by the most celebrated Grecian masters. It had been destroyed seven or eight times before Pliny wrote, particularly by the notorious Herostratus, 356 B.C. The temple, however, was rebuilt by the Ephesians with more magnificence than ever, whose women contributed their trinkets to the general fund raised for this purpose. There were also many other temples here, a theatre, a stadium or race-course, gymnasium, odeum, etc. The site of the temple had become lost when it was discovered by Mr. Wood in 1867-69. In his excavations he found that the building measured about 343 feet by 164, and stood on a raised platform measuring 418 feet by 239. Important excavations have since been carried out here by the Austrian Archæological Institute and the theatre, important buildings connected with the gymnasium, and a splendid semicircular marble portico round the east side of the harbor have thus been disclosed. In the double church of Saint Mary the Virgin the Council of Ephesus was held in 431. The Great Mosque or Church of Saint John, the cave of the Seven Sleepers, and other interesting objects are to be seen here. Consult Wood, 'Discoveries in Ancient Ephesus' (1877).

**EPHESUS, Council of**, the third general council of the Roman Catholic Church, held at Ephesus in June 431, principally to oppose the heresy of Nestorius, patriarch of Constantinople. It was convoked by the Emperor Theodosius II at the instance of Pope Celestine I and many Catholic bishops. Cyril, bishop of Alexandria, presided on behalf of Pope Celestine I. The number of bishops in the Council was about 200.

Nestorius, adopting the teaching of Theodorus of Mopsuetia, denied the Church's doctrine of the incarnation, and held that instead of the Word being made man, he (the Word) simply had his special abode in the man Jesus Christ; and that hence Mary the Virgin was not θεοτόκος God-bearing, mother of God, but only χριστοτόκος, mother of the Christ. The Council declared that Mary is θεοτόκος, *Deipara*, and that Jesus Christ is God and man. (See COMMUNICATION). Nestorius was deposed and excommunicated. It was not, however, until some years afterward that his supporters acquiesced in this finding. Nestorius himself was ordered by the emperor to retire to his monastery near Antioch. Another Council was held at Ephesus — the "robber synod," as it is called — in August 449 convoked by the same emperor to deal with questions of faith connected with the teachings of Theodorus and Nestorius. The presiding bishop, Dioscurus of Alexandria, backed by a rabble of monks, soldiers and servants overawed the 135 bishops, compelling them to sign blank papers on which he wrote what decrees he pleased. Consult Bright, W., 'The Canons of the First Four General Councils, etc.' (Oxford 1892); Christal, J., 'Authoritative Christianity' (Jersey City, 1901); DuBose, W. P., 'The Ecumenical Councils' (in 'Ten Epochs of Church History,' Vol. III, New York 1896); Ficker, G., 'Euthérius von Tyana, etc.' (Leipzig 1908); Hammond, W. A., 'The Definitions of Faith, and Canons of Discipline of the Six Ecumenical Councils' (New York 1844); Hefele, K. J. von, 'A History of the Councils of the Church' (Vol. III, translated by C. W. Buch, Edinburgh 1883); Nau, F. and others, translators, 'Nestorius. Le Livre d'Héraclide de Damas' (Paris 1910); Percival, H. R., 'The Seven Ecumenical Councils of the Undivided Church, etc.' (in 'A Select Library of Nicene and Post-Nicene Fathers,' 2d Series, Vol. XIV, New York 1900); Perry, S. G. F., ed., 'The Second Synod of Ephesus, etc.' (Dartford 1881); Rivington, L., 'The Council of Ephesus and Anglican Writers' (in *Dublin Review*, Vols. CX-CXI, London 1892); 'Papal Supremacy at the Council of Ephesus' (*Ibid.*, Vol. CXVI, London 1895).

**EPHIALTES.** (1) The Malian who conducted the Persians over a mountain path and enabled them to surprise Leonidas and his Spartans at Thermopylæ with a rear attack. (2) The son of Poseidon and Iphimedia.

**EPHOD**, commonly believed to have been a species of vestment woven of gold, blue, purple, scarlet, and fine twined linen, worn by the Jewish high-priest. According to Exodus xxviii, 6 ff. and xxxix, 2 ff. it consisted of two main pieces, one covering the back, the other the breast and upper part of the body, fastened together on the shoulders by shoulder straps. On each shoulder was an onyx stone set in gold, on which were engraved the names of six tribes according to their order. A girdle or band, of one piece with the ephod, fastened it to the body. Just above the girdle, in the middle of the ephod, and joined to it by little gold chains, rested the square breastplate or pouch with the Urim and Thummim. The ephod was originally intended to be worn by the high-priest exclusively, but a similar vestment made of linen was worn in later times by priests of



lower rank. In more recent times considerable discussion has been carried on in regard to the true nature and appearance of the ephod. Some investigators claim that it was a shrine, some that it was just a pouch somewhat on the order of a loin cloth, and still others that it was an instrument of divination. However, inasmuch as all the evidence on which these investigations are based is more or less circumstantial and indefinite the question is still unanswered and is likely to remain so. Consult Elhorst, H. J., 'Das Ephod' (in *Zeitschrift für die alt-testamentliche Wissenschaft*, Vol. XXX, p. 259, Giessen 1910); Foote, T. C., 'The Ephod' (in *Journal of Biblical Literature*, Vol. XXI, p. 1, Boston 1902); Macklenburg, A., 'Über den Ephod in Israel' (in *Zeitschrift für Wissenschaftliche Theologie*, Vol. XLIX, n. F. Vol. XIV, p. 433, Leipzig 1906).

**EPHORS**, ἔφ'ὄρς, or **EPHOROI**, magistrates common to many ancient Greek communities. The most celebrated were the Ephoroi of Sparta. The origin of the office is uncertain and it is very doubtful that they were instituted by Lyncurgus. They were five in number, and in historical times were elected by the people annually, their authority being designed as a counterpoise to that of the king and council. They superintended the morals and domestic economy of the community; scrutinized the conduct of all officials, and even summoned the kings before their tribunal. The judicial authority and executive power eventually fell almost entirely into their hands; they became autocratic, opposed the extension of popular privileges, and arousing the antagonism of the kings and people, were suppressed by Cleomenes III, the latter murdering the Ephors 225 B.C. After his fall in 221 B.C. the office was revived, but never regained its influence. There is a very extensive literature on the subject, almost entirely in German. Besides articles in the various 'Histories of Greece' (q.v.), there is a very exhaustive, but rather technical article by Szanto in Pauly-Wissowa 'Real-Encyclopädie der Klassischen Altertumswissenschaft' (Vol. V, Stuttgart 1907). Consult Dum, G., 'Die Entstehung und Entwicklung des Spartanischen Ephorats' (Innsbruck 1878); Kuchtner, K., 'Entstehung und Ursprüngliche Bedeutung des Spartanischen Ephorates' (Munich 1897); Stein, H. K., 'Das Spartanische Ephorat bis auf Cheilon' (Paderborn 1870); Stern, E. von, 'Zur Entstehung und Ursprünglichen Bedeutung des Ephorats in Sparta' (Berlin 1894).

**EPHORUS**, Greek historian, flourishing in the 4th century B.C., from about 400 to 330 B.C.; was born at Cyme, in Aebolis, Asia Minor. Little is known concerning his life, but it is related that he studied under Isocrates and that the latter, after training him in rhetoric, persuaded him to abandon oratory for history, and that it was upon his suggestion that he prepared his universal history. This work *Ἱστορίαι*, in 30 volumes, was the first history ever written in Greece and was remarkable for its wealth of material and also for the fact that each book, containing a compact portion of the history with an introduction, was complete in itself. The history deals with the Greeks (outside of the mythical age) from the return of the Heraclidae to the siege of Perinthus (340 B.C.), covering a period of over 700 years. His style of

writing was loose and feeble, well meriting the alleged remark of Isocrates, that he needed the spur, as Theopompus the bit. The history was used and praised, however, by Polybius, Diodorus and Strabo. The main portions of the manuscripts have perished, only a few fragments remaining, which were published in 'Fragmenta Historicorum Græcorum' (C. Müller, ed., Vol. I, p. 234-277, Vol. IV, p. 641, Paris 1841). An older collection, 'Ephori Cumæi Fragmenta,' (Karlsruhe 1815) was edited by M. Marx. Consult Bury, J. B., 'The Ancient Greek Historians' (New York 1909); Schwartz, E., 'Ephorus' (in Pauly-Wissowa 'Real-Encyclopädie der Klassischen Altertumswissenschaft,' Vol. VI, p. 1, Stuttgart 1907); id., 'Die Zeit des Ephoros' (in *Hermes*, Vol. XLIV, p. 481, Berlin 1909).

**EPHRAEM SYRUS**, ἔφρα-ἔμ σῖρ'ῦς, **SAINT EPHREM**, or **EPHRAM** (the Syrian), Syrian theologian: b. Nisibis, Mesopotamia, about 306; d. Edessa, Mesopotamia, 373. He lived in Nisibis till 363 and played an important part in defending his native city against the various sieges to which the Persians submitted it. When the Emperor Jovian gave up the town to the Persians in 363, he, together with its other Christian inhabitants, left. He finally settled in Edessa where he continued to reside till he died, except for intervals which he spent in prayer and meditation in the desert and except for a journey to Egypt and a visit to Saint Basil, Archbishop of Cæsarea in Cappadocia. He held humble rank in the hierarchy, that of deacon, but as a preacher attained high celebrity. He refused to be ordained a priest because he thought himself unworthy. His writings were very numerous, and many are extant. He used a poetic form in his homilies and harangues; and Saint Jerome tells us that his homilies (translated into Greek, for he wrote in Syriac) were wont to be read in many of the churches of Greece immediately after the Scripture lesson. He was a valiant defender of Catholic orthodoxy against the heretics of his time — Bardesanes, the Gnostic, the Arians, and the Sabellians, the Manichæans and the Novatians. Some of his lyrics are remarkable for their simplicity and genuine poetic spirit. Even his homilies are of a poetic cast and form. His works have been collected and translated into Latin, Greek, German and English. There are also Armenian, Arabic, Coptic and Ethiopic versions of the original Syriac. The most important translations and collections, many of which are preceded by accounts of his life, are: 'Omnia Opera S. Ephræmi Syri' (G. Vossius, ed., 3 vols., Rome 1589-98); 'Greek Text of 156 Writings of Saint Ephrem' (E. Thwaites, ed. Oxford 1709); 'S. P. M. Ephræm Syri Opera Omnia Quæ Extant Græce, Syriace, et Latine' (J. S. Assemanus and S. E. Assemanus, ed., 6 vols., Rome 1732-46); 'Ausgewählte Schriften des Heiligen Kirchenvaters Ephram' (F. Zingerle, ed., 6 vols., Innsbruck 1831-46); 'Saint Ephrem's Commentaries on the Epistles of Saint Paul' (Latin text, Aucher, ed., 4 vols., Venice 1836); 'Select Works of Saint Ephrem the Syrian' (J. B. Morris, transl., Oxford 1847); 'Repentance of Nineveh' (H. Burgess, transl., London 1853); 'Select Metrical Hymns and Homilies, etc.' (H. Burgess, transl., London 1853); 'S. Ephræmi Syri, Rabulæ Epis-

copi Edesseni, Batzei, Aliorumque Opera Selecta' (Syriac text, J. J. Overbeek, ed., Oxford, 1865); 'S. Ephræmi Syri Carmina Nisibena, etc.' (Syriac and Latin texts, G. Bickell, ed., Leipzig 1866); 'Commentaries on the Concordance of the Gospels' (Latin text, Moesinger, ed., Venice 1878); 'S. Ephræm Syri Hymni et Sermones' (Syriac and Latin texts, T. J. Lamy, ed., Malines 1882); 'S. Ephræm Syri Commentarii in Epistolas D. Pauli, etc.' (Venice 1893); 'Fragments of the Commentary of Ephrem Syrus Upon the Diatessaron' (J. R. Harris, ed., London 1895); 'Selections Translated into English from the Hymns and Homilies of Ephraim the Syrian' (J. Gwynn, ed. and transl., in 'A Select Library of Nicene and Post-Nicene Fathers,' 2d ser., Vol. XIII, pt. 2, p. 112, New York 1898). Consult Alsleben, 'Das Leben des H. Ephrem' (Berlin 1853); Ferry, S., 'Saint Ephrem, Poète' (Paris 1877); Lamy, T. J., 'Saint Ephrem Syrus' (in *Dublin Review*, 3d ser., Vol. XIV, p. 20, London 1885).

**EPHRAIM**, *é'frâ-im*, according to Gen. xli, 50-52, the younger son of Joseph and of Asenath and the founder of one of the 12 tribes of Israel. The tribe occupied one of the finest and most fruitful territories of Palestine; in the very centre of the land, and included the most of what was afterward called Samaria. Its approximate boundaries were: on the east the river Jordan, on the west the Mediterranean Sea and the tribe of Dan, on the south the tribe of Benjamin, and on the north that of Manasseh. The Ephraimites, when they left Egypt, are said to have numbered 40,500, and, being numerous and influential, often appear as the representatives of the 10 tribes, both in historical and prophetic passages of the scriptures. For a long time the ark and the tabernacle were situated at Shiloh in the heart of Ephraim. The tribe was the most warlike of all the Israelites as attested by their protests against Gideon (Judges viii, 1) and against Jephthah (Judges xiii, 1-7) because they did not ask their aid in war. Joshua, who conquered the Holy Land, and Samuel, the prophet, were members of the tribe. Upon the death of Saul, the Ephraimites, in conjunction with all the other tribes except Judah, took part in the revolt of Saul's son Eshbaal (Ishbosheth), and recognized him as legitimate king in opposition to David (2 Sam. ii, 8-9), but upon his murder, submitted to the hegemony of Judah under David. Later, about 975 B.C., after the death of Solomon, the tribe revolted under Jeroboam against Rehoboam, the son of Solomon (1 Kings xii, 1-20), and with all the tribes except Judah, Simeon, part of Benjamin, and the Levites, merged into the northern kingdom of which they constituted the most important part. There are, of course, numerous references to Ephraim in many parts of the Old Testament. A list of these may be found in the article by H. W. Hogg in Vol. II of *Encyclopædia Biblica* (London 1901). Consult also English Commentaries on Bible, Old Testament, Exodus.

**EPHRAIM**, town of Palestine, mentioned in John xi, 54, as a place where Jesus took temporary refuge. A town of this name is mentioned twice in the Old Testament and by Josephus, and is probably the same place. Nothing is known of its history. Modern attempts to identify it with Et-Taiyibeh, four

miles northeast of Beitin, the ancient Bethel, do not rest on any secure foundation beyond the fact that it best corresponds to the New Testament description as "near the wilderness."

**EPHRAIM CODEX.** See BIBLE.

**EPHRATA**, Pa., township and borough in Lancaster County; on the Philadelphia and Reading Railroad, about 50 miles northwest of Philadelphia. It is an agricultural and mining region with forests nearby. It is a health resort and has manufactories of cigars, silk, underwear and hosiery. The borough owns its waterworks and electric-light plant. Ephrata was founded by Johann Conrad Beissel (q.v.) and his followers in 1735. The community established by Beissel was called "Order of the Solitary," and it resembled somewhat the Seventh-Day Adventists. Ephrata contains several very ancient and singular buildings, particularly the brother and sister house. These houses are large four-story structures, each contains a chapel, and is divided into small apartments, so that six dormitories, barely large enough to contain a cot, a closet, and hour glass, surround a common room, in which each mess have their meals. The dress of the brethren and sisters was that of the Franciscans or White Friars. They were remarkable for their rigid adherence to the precepts and ordinances of the New Testament; they insisted upon the washing of the feet before administering the sacrament; and were very observant of the Sabbath. They were peaceful and temperate and distinguished for their music, which was composed and arranged by themselves. Prior to the Revolution they seemed to flourish, but now only a few of the order remain. Many of the members were well educated; Peter Miller, second prior of the monastery, translated the Declaration of Independence into seven languages, at the request of Congress. A printing press was set up, and a number of works, in both English and German, some of them very beautifully made and now highly prized, were published. Pop. of townships, 2,565; borough, 3,192. Consult Gibbons, 'Pennsylvania Dutch and Other Essays' (1872); Kuhns, 'German and Swiss Settlements of Colonial Pennsylvania'; Sachse, 'The German Sectarrians of Pennsylvania' (2 vols., 1900).

**EPHYDRA**, a genus of flies, of the Ephydridæ, the eggs and larvæ of which were considered a dainty by the aborigines of America. See FLY.

**EPIBLAST**, one of the layers in the developing embryo from which the structures making up the skin and its appendages are developed; also called ectoderm. See EMBRYOLOGY.

**EPIC.** See NARRATIVE POETRY.

**EPICARDIUM.** See HEART.

**EPICHRMUS**, Greek philosopher and comic poet: b. Cos, about 540 B.C.; d. 450 B.C. He lived at Syracuse, and there wrote his celebrated comedies, now lost. Their number is reckoned at 52, and the titles of 35 of them have been preserved. Very little is known definitely about his life. But it is said that, before commencing his career as a comic poet, which apparently he did somewhat late in life, he lived at Megara, engaged in the study of philosophy, both physical and metaphysical. The

fragments of his writings which are preserved abound with philosophical maxims, and with speculative discourses. His genius was highly esteemed among the ancients by such judges as Plato and Cicero. The Sicilian comedy of Epicharmus, prior to the Attic, grew out of the mimes, which were peculiar to this island, making a sort of popular poetry. He arranged the separate unconnected scenes, exhibited in the mimes, into continued plots, as in tragedy. His comedies were long regarded as models in this species of composition, and were as much distinguished by their knowledge of human nature as by their wit and lively dialogue. The Sicilian comedy, in opposition to the Attic-Ionic, is also designated as the Doric comedy and is written without chorus. As their subject matter Epicharmus chose mythological incidents which he travestied or characters from everyday life. He wrote in trochaic and anapaestic tetrameter. The best and most recent collection of his fragments is contained in 'Poetarum Græcorum Fragmenta' (G. Kaibel, ed., Vol. VI, Berlin 1899). Consult Koerte, A., 'Die Griechische Komödie' (Leipzig 1914).

**EPICÆNE, or THE SILENT WOMAN,** a comedy by Ben Jonson, produced in 1609. An old man, named Morose, disliking noise marries Epicæne because of her good reputation as a good listener and also with the aim of disinherit a nephew. Immediately after marriage Epicæne displays an exceedingly shrewish disposition. Morose, in order to be rid of her, secures the services of his nephew by gifts and promises of reward. The nephew then discloses Epicæne as a boy in disguise, who had been induced to play this trick upon Morose.

**EPICONTINENTAL SEAS,** those shallow seas which cover the continental shelf (q.v.) and which from time to time have covered most parts of this and other continents in the geologic past. The term is in contrast to the deep seas which have been more persistent in their history.

**EPICTETUS,** Stoic philosopher: b. Hierapolis, Phrygia, about 60 A.D. He lived at Rome, where he was the slave of Epaphroditus, a brutal freedman of Nero, whose abuse and maltreatment he bore with fortitude. He was later manumitted. Epictetus himself did not leave any written account of his doctrines, which appear to have been of the most elevated kind. In his discourses he aimed to impress his hearers with the love of practical goodness. The foundation of philosophy he held to be the perception of one's own weakness and inability to do what is needful. His doctrines approach more nearly to Christianity than those of any of the earlier Stoics, and although there is no trace in what is recorded of them of his having been directly acquainted with Christianity, it is at least probable that the ideas diffused by Christian teachers may have indirectly influenced them. The excellence of his system was universally acknowledged. Banished from Rome by Domitian who hated him on account of his principles, Epictetus settled in Ephesus, and although he possessed the favor of Hadrian, there is no evidence that he returned to Rome. His pupil Arrian, the historian of Alexander the Great, collected his maxims with affectionate care, in the work entitled 'Enchiridion' ('Handbook') and in eight books of 'Commen-

taries,' four of which are lost. These reveal the simple and noble earnestness of the philosopher's character, as well as that real heartfelt love of good and hatred of evil which is often assumed to be an exclusively Christian feeling. (See DISCOURSES). Consult the complete edition of his works by Schenkl (Leipzig 1898), and the translation by Carter (London 1758), Higginson (2 vols., Boston 1890) and Long (London 1897). Consult also Arnold, 'Roman Stoicism' (Cambridge 1911); Melcher, 'De Sermone Epictetes' (Halle 1906); Ritter and Preller, 'Historia Philosophiæ Græcæ' (9th ed., Gotha 1913).

**EPICUREANISM.** Epicureanism as a philosophical doctrine has its rise in the teachings of its founder Epicurus, who was borne in Samos in the year 342 or 341 B.C. He was the son of Neocles and Chærestrata. His father's name being the same as that of the great statesman Themistocles, suggested to the poet Menander a verse in which he contrasts the son of Neocles, who freed his country from slavery, with him who freed it from foolishness. In his early life, Epicurus taught in several schools in Asia Minor and in the year 306 came to Athens, where he founded a school of his own. By the subtle charm of his personality he attracted to himself a group of admiring friends and followers who were not only devoted to the teacher but were also fired with enthusiastic zeal for his teaching. They were his companions and friends rather than his pupils. Their meeting place was the famous garden of the master which has become so closely associated with the very name of the school. After the death of Epicurus in 270 his followers carried on his work and maintained the teachings and traditions of their leader with unabated earnestness and loyalty. Among the successors of Epicurus, the most conspicuous perhaps are Hermarchus, Dionysius, Apollodorus, Zeno and Phædrus. But no one of his followers achieved marked distinction until we come to the time of T. Lucretius Carus, the interpreter and chief apostle of Epicureanism. Though a Roman, he had caught that Greek spirit which had been so brilliantly illustrated in the garden of Athens.

Epicureanism as a distinct school flourished with varying fortunes until a period as late as the 4th century A.D. With the decay and disappearance of the school, its influences however did not cease, but lived on, and will live; for Epicureanism represents an attitude of mind which will ever appeal most strongly to certain natures, and in a way to all natures. It is not in a strict sense of the phrase, a system of philosophy. It is rather a theory of life. It is essentially practical in its purposes, methods and results. So far, however, as Epicureanism may be called a system of philosophy, it falls into three parts—a system of canonic, of nature and of morality. By canonic is meant a system which exhibits certain canons or tests of truth. With Epicurus the supreme test of truth was to be found in the sensations. It is the same thought as that which is contained in the old adage—seeing is believing. He held that only the actual facts of a sensory experience can furnish a scientific basis upon which to construct a body of knowledge. The notions are to be regarded merely as generalized sensations, and all opinions are inferences which at the

last analysis must rest upon simple sensations. The sensation as such, therefore, is the court of last appeal. Concerning his philosophy of nature, Epicurus taught that there were only natural causes. Any belief in supernaturalism he regarded as a superstition which only a weak intellect could possibly entertain. As regards the constitution of matter, he followed Democritus in the essential features of his atomic theory of the universe. He did not follow, however, with complete rigor the logic of his materialistic conceptions, for he allowed that there must be a distinction between the irrational, or more sensory part of the soul on the one hand, and on the other, the rational part which he regarded as the superior and controlling power of man's nature. Moreover, while denying the existence of the gods, as gods of providence sustaining the forces of nature, and ruling the destinies of man, he nevertheless believed in their existence as beings apart and wholly separate from mundane affairs. From the standpoint of his ethical system, the gods were of very necessity beings supremely happy, and such they could not be, were they supposed to be in any way cognizant of the darker side of nature and the manifold ills of human life. According to Epicurus the great end to be attained through the study of nature was to disabuse the mind of any lurking superstition concerning the possibility of the supernatural.

It is, however, the ethical system of Epicurus which is the heart of his teaching, and it is this system that the term Epicureanism usually suggests to one's mind. With Epicurus man's chief end is the attainment of pleasure,—not in the sense, however, that life is a heedless pursuit of pleasure here, there and everywhere. The end is pleasure, not pleasures. The supreme pleasure, the constant source of all other pleasures, is the tranquil and happy mind. In placing the true source of pleasure within, Epicurus here differs from the earlier Cyrenaic who regarded man's happiness as consisting in the full round of delights, the sum total of all his actual enjoyments. Epicurus taught that mere bodily pleasures were not an end in themselves, but only as they minister to peace of mind. Violent excesses disturb, extreme asceticism torments the inner spirit of man. Therefore be not too indulgent, nor too rigorous with self. Study to attain the maximum of enjoyment with the minimum of distress. Let a wise prudence transmute both the good and the evil of life into a tranquillity of soul. In this conception of conduct, virtue is never an end in itself. It is always a means to an end. The end is happiness and so far as a life of virtue contributes to well-being, so far only is it to be commended.

We find in Epicureanism and in Stoicism alike, the common endeavor to free man from the dominion of circumstance, and to establish an inner world of mind wholly independent of the outer world of chance events, of untoward influences, of hostile forces and fleeting delights. The Stoic, however, urged the repression of all desire; the Epicurean, on the other hand, urged its wise regulation. As Epicurus himself puts it, "It is not an unbroken succession of drinking feasts and of revelry, not the pleasures of sexual love, nor the enjoyment of the fish and other delicacies of a splendid table, which produce a pleasant life, it is sober reasoning,

searching out the reasons for every choice and avoidance, and banishing those beliefs through which greatest tumults take possession of the soul. Of all this, the beginning and the greatest good is prudence. Wherefore prudence is a more precious thing even than philosophy: from it grow all the other virtues,—for, it teaches that we cannot lead a life of pleasure which is not also a life of prudence, honor and justice, nor lead a life of prudence, honor and justice which is not also a life of pleasure. For the virtues have grown into one with a pleasant life, and a pleasant life is inseparable from them." In dealing with the fear of death Epicurus proved that the dissolution of the body involves that of the soul, and therefore death is nothing to us, because when we are, death is not; and when death is, we are not.

**Bibliography.**—Asener, 'Epicurea' (Leipzig 1887); Cassel, 'Epikur der Philosoph' (Berlin 1892); Geodeckemeyer, 'Epicurus' Verhältnis zu Demokrit in der Naturphilosophie' (Strassburg 1897); Gizycki, 'Ueber das Leben und die Moralphilosophie des Epicurus' (Halle 1879); Gomperz, 'Herculanische Studien' (Leipzig 1866); Guyan, 'La Morale d'Epicure' (3d ed., Paris 1886); Joyau, 'Epicure' (ib. 1910); Kreibitz, 'Epicurus' (Vienna 1886); Lange, 'History of Materialism' (Boston 1886); Pater, W., 'Marius the Epicurean' (latest ed., 2 vols., New York 1913); Santayana, 'Three Philosophical Poets' (Cambridge, Mass., 1910); Taylor, 'Epicurus' (London 1911); Trezza, 'Epicuro e l'Epicureismo' (Florence 1877); Wallace, 'Epicureanism' (London 1880); Watson, 'Hedonistic Theories' (Glasgow 1895).

JOHN GRIER HIBBEN,  
*President of Princeton University.*

**EPICURUS**, ĕp-ĭ-kŭ'rus, Greek philosopher: b. Samos 341 B.C.; d. Athens 270 B.C. He went to Athens 323 B.C., where he is said to have enjoyed the instructions of Xenocrates, then at the head of the Academy, but this he himself does not admit. Epicurus generally denied his obligations to other philosophers. Although some parts of his system are evidently borrowed from his predecessors, he claimed to be self-instructed, and treated his teachers with hostility and contempt. His stay at Athens, however, was brief; and on leaving it he went to Colophon, where his father was engaged in teaching, and began himself to give lessons in grammar. It was here, according to some accounts, that his attention was first turned to philosophy. He himself says he began his philosophical studies at the age of 14, but they may have subsequently taken a more distinct development. The inability of the grammarians to explain a passage about Chaos and the accidental possession of a copy of the works of Democritus are variously assigned as the cause of this new or more decided direction of his mind. From Colophon he went to Mytilene and Lampsacus, where he engaged in teaching philosophy. He returned to Athens in 306 and purchased a garden in a favorable situation, where he established a philosophical school. Here he spent the remainder of his life except for short visits to Asia Minor. His mode of life appears to have been simple and temperate. He abstained, as a principle, from politics, and took no part in public affairs. During the latter part of his life he was afflicted with severe physical suffering which was borne with heroic courage.

Epicurus was a very voluminous writer. He wrote some 300 separate treatises. His works, however, are represented as full of repetitions and quotations. In ancient times his philosophy appears to have been more popular in Greece than in Rome, although his disciples were numerous in both. This is easily comprehended, as it was in fact a system engendered by the decline of public virtue in Greece, while the severest stoical philosophy was better adapted to the still active public spirit of Rome. Little is left of his numerous writings. Some fragments of a 'Treatise on Nature,' which is known to have consisted of 37 parts, were found at Herculaneum and published by J. C. Orellius (Leipzig 1818). All other fragments have been published by H. Usener in his 'Epicurea' (Leipzig 1887). The chief account of his philosophy is contained in the great poem of Lucretius, 'De Rerum Natura,' one of the masterpieces of Roman literature. A good edition of the latter is that by W. A. Merrill (New York 1907). There is also a translation by H. A. J. Munro (London 1908). Consult 'Epicurus and His Sayings' (in *Quarterly Review*, Vol. CLXXXV, p. 68, London 1897); 'Epicurus and Lucretius' (in *Westminster Review*, n. s. Vol. LXI, p. 299, London 1882); Du Rondel, J., 'La Vie d'Epicure' (La Haye 1686); Gassend, P., 'De Vita et Moribus Epicuri' (1647); Girard, J., 'Etudes sur la Poésie Grecque,' etc. (Paris 1884); Gomperz, T., 'Greek Thinkers' (4 vols, London 1901-12); Guyau, M., 'La Morale d'Epicure' (Paris 1881); Hicks, R. D., 'Stoic and Epicurean' (New York 1910); Kreibitz, J., 'Epikur' (Leipzig 1886); Reale Accademia Ercolanese di Archeologia, 'Herculanensium Voluminum Quæ Supersunt' (11 vols., Naples 1793-1857); Taylor, A. E., 'Epicurus' (New York 1911); Wallace, W., 'Epicureanism' (London 1880).

**EPICYCLE**, in ancient astronomy, a small circle supposed to move round the circumference of a larger, a hypothetical mode of representing the apparent motion of the planets, which were supposed to have such a motion round the circumference of a large circle, called the deferent, having the earth in its centre. See **ASTRONOMY**.

**EPICYCLOID**, in geometry, is a curve generated by a point in one circle, which rolls on the convexity of the circumference of another circle. If the rolling circle is inside the fixed circle the curve generated is a hypocycloid. The common cycloid is generated by a point in a circle that rolls along a right line. The latter has sometimes been assimilated with the former by considering the right line as the circumference of a circle whose diameter is infinite. The invention of epicycloids is ascribed to Roemer, the Danish astronomer. See **GEOMETRY**.

**EPICYCLOIDAL WHEEL**, a wheel or ring fixed to a framework, toothed on its inner side and having in gear with it another toothed wheel of half the diameter of the first, fitted so as to revolve about the centre of the latter. As the inner wheel revolves a point on its periphery will oscillate in a straight line. It is used for converting circular into alternate motion, or alternate into circular.

**EPIDAMNUS**. See **DURAZZO**.

**EPIDAUROS**, ἐπίδαρ'ος, one of the most important towns and commercial seaports of ancient Greece, situated in Argolis, on the east coast of the Peloponnesus, particularly celebrated for its magnificent temple of Æsculapius, which stood on an eminence eight miles west of the town. An inscription over the entrance declared it to be open only to pure souls. Crowds of invalids resorted to the place in hopes of obtaining a cure from the beneficent divinity, in whose honor festivals were celebrated yearly. It received its name from Epidaurus, a son of Argus and Evadne. Excavations made by the Greek Archæological Society have brought to light parts of Tholos; a temple, probably that of Æsculapius, 81 feet long by 43 feet wide; the theatre, which is the most perfect example of Greek theatre in existence; stadia, baths, gymnasia and hospital. Epidaurus is now called Pidavro, or Edidairo, and is the place where in 1821 the first Greek Congress assembled. The modern town contains about 100 inhabitants. Consult Caton, 'Epidaurus' (1900); Diehl, 'Excursions in Greece' (1893); Delfrasse and Lichat, 'Epidaur' (1895); Gardner, 'New Chapter in Greek History' (1892).

**EPIDEMIC**. See **EPIDEMIOLOGY**.

**EPIDEMIC CEREBROSPINAL MENINGITIS**. See **MENINGITIS**.

**EPIDEMIOLOGY**, the study of epidemics or the science that treats of those diseases that are known to attack a number of persons at the same time or in close succession. The essential feature is that epidemic diseases belong to a group of infective or microparasitic maladies which have the common property of spreading from time to time in a community. It is well known that many diseases of an epidemic character have their favorite haunts. In such places they are always present and there they are said to be endemic. It is only when they appear in large numbers of people in their favorite habitats that they assume epidemic proportions. Thus there is little distinction between the two classes of disease, since the same disease may be at one time both endemic and epidemic. When an epidemic disease, for instance, influenza, spreads the entire world over, the word pandemic is applied. The essential feature in an epidemic disease is that it must have a definite contagium. The contagia may be either of bacterial or protozoan character. Thus cholera, dysentery, the plague are caused, as is known, by bacteria which, being carried in the ordinary paths of commerce, or by bodies of a moving population, are spread about the world. Occasionally epidemic disease is due to an animal parasite. This is presumed to be the case in yellow fever, and is known to be true of malaria. In malaria, as is now positively demonstrated, the agent that is all-important in the spreading of the disease is one genus of mosquito, *Anopheles*. The parasite lives normally in the human body and is conveyed by means of the blood into the mosquito, where it undergoes a special cycle of development, until it is inoculated into another human being, who develops the disease.

The importation of epidemic and parasitic disease from Africa and Asia is now urged as a reason for extreme precaution in the contact of whites with alien races. The importation of

such diseases from Africa is now considered to have contributed materially to the downfall of the Roman Empire. The negroes, according to recent investigation, are responsible for the introduction into the Southern States of malarial fever, which they brought in their blood from Africa, and to which, themselves immune, the whites fell victims. Similarly the American negroes, according to a discovery made by Dr. Stiles in 1902, carry in their intestines the virus of hookworm with relatively slight discomfort; but not so the white population; and to this cause is set down the physical inefficiency and mental inertia which afflict so many of the Southern whites. Cholera, bubonic plague, typhus and smallpox have all had their origin in Asia.

Further, it may be said that the essential features for the development of epidemic conditions are (1) A virus; (2) a susceptible population; (3) free intercommunication between the sick and the susceptible. In the group in which the animal parasites belong there must be (1) A virus; (2) a breeding-place outside of man; (3) a means of transport from place to place, either naturally or artificially; (4) a vehicle for the diffusion of the disease, such as the mosquito, for instance, or a contaminated water-supply, or a person suffering from the disease who travels from place to place and (5) a susceptible population. It is well known that variation in the susceptibility of populations is a very important element in the consideration of epidemics. Thus measles, whooping-cough, diphtheria and similar affections ravaged Hawaiian (formerly Sandwich) Islands with a fierceness and mortality unknown to modern times. Seasonal movements, sectional fluctuations, time fluctuations and oscillations are interesting features in the study of epidemics. By some writers the word epidemic is very loosely used to indicate certain waves of mental excitation which have caused and still cause mental storms throughout the community, as the dancing mania and similar occurrences. These cannot be spoken of as epidemics in the true sense unless one wishes to use the broad term of "emotional contagion." Some of the most interesting epidemics of modern years have been the influenza epidemic of 1890, which traveled round the world in from three to four years, and the plague epidemic that was raging from 1895 to 1902, slowly traveling over the habitable globe. There have been no severe extensive epidemics in the United States, save the epidemic of influenza, for a great many years, and in civilized countries at the present time the chances for the spreading of more severe epidemics are greatly lessened by the application of the laws of modern hygiene as well as by procedures arising from the newly acquired knowledge concerning immunity. The time does not seem far distant when immunity from many forms of infectious disease may be conferred by proper serum therapy. Consult Creighton, 'The History of Epidemics in Great Britain from 664 A.D. to the Extinction of the Plague' (2 vols., Cambridge 1891-94); Hecker, 'Epidemics of the Middle Ages' (trans. by Babington, 2 vols., London 1835); Hirsch, 'The Geographical Distribution of Disease' (1893); Weichselbaum, 'Epidemiologie' (1900); and 'Epidemiology' (in 'Encyclopædia Medica,' 1900).

**EPIDENDRUM**, a large genus of tropical American orchids, most of the species of which are epiphytic, growing on trees. There are upward of 500 species in South America alone. The stems develop pseudo-bulbs, the leaves are strap-shaped and leathery and the flowers are single or in spikes, panicles or racemes. The flowers of some species are very handsome and a large number of the species are in cultivation. Two of the finest cultivated species are the Mexican plants *E. nemorale* and *E. vitellinum*, the former with rose-colored and the latter with orange-colored flowers. The plants are much used in hybridization, as they are hardy and rigorous, and are valuable for crossing with the less hardy species of other genera, the result being in many cases long-stemmed flowers of fine appearance.

**EPIDERMIS**, the outer layer of the skin. See SKIN.

**EPIDIDYMISS**, an organ lying beside the testicle and transmitting the semen to the vas deferens. See TESTICLE.

**EPIDIDYMITIS**, inflammation of the epididymis, resulting in pain, redness, heat and swelling of the testicle, with general constitutional malaise. Treatment consists in rest in bed and soothing applications.

**EPIDOTE**, a common mineral, usually yellowish-green in color, and crystallizing in prismatic forms belonging to the monoclinic system. It is a silicate of calcium, iron and aluminum, with the general formula  $\text{HCa}_2(\text{Al, Fe})_2\text{Si}_2\text{O}_8$ , the ratio of the aluminum to the iron varying, in different specimens, from 6:1 to 3:2. Its hardness is from 6 to 7 and its specific gravity is about 3.4. Epidote occurs throughout the world. Fine crystals are found in France, the Tyrol, Haddam, Conn., Calumet, Colo., and Alaska. The epidote group contains, in addition to epidote proper, the minerals piedmontite and allanite, which resemble it in general nature but contain manganese and cerium respectively; and also the calcium epidote, zoisite, which crystallizes in the orthorhombic system.

**EPIGÆA**, ĕp-i-jé'a. See ARBUTUS, TRAILING.

**EPIGASTRIUM**, the upper fore part of the abdomen, reaching from the pit of the stomach to an imaginary line above the umbilicus (navel) supposed to be drawn from the one extremity of the last false rib, on one side, to the corresponding point on the other.

**EPIGENE**, a term applied to those geological agents of change which affect chiefly the superficial portions of the earth's crust, as the atmosphere, water, plants and animals.

**EPIGENESIS**, ĕp-i-jĕn'ĕ-sĭs, in biology, the development of the animal from the simple protoplasm of the egg. This term therefore expresses the theory and process of embryology as now understood, and is opposed to the prevailing theory, previous to the researches of Harvey, and especially of Wolff and Von Baer, which was then known as the *emboitment* theory, an account of which is given under PRR-FORMATION. See also EMBRYOLOGY.

In physiology the supposed production in organized beings of or additional formations by means of new vital influences, as opposed to the idea that new parts are simply the result of developments or changes in pre-existing structures.

**EPIGENETIC.** See SYNGENETIC.

**EPIGLOTTIS**, the cartilage at the root of the tongue forming a valve which partly closes the aperture of the larynx (q.v.) during the process of swallowing. When respiration takes place the epiglottis is vertical but falls back and covers the larynx on the approach of food. Any portion of food, however minute, entering the sensitive larynx, causes distress and is automatically ejected by a spasm of coughing.

**EPIGONI**, a name given in Greek legend to the sons of the seven Greek chiefs who conducted the expedition against Thebes in the war between Eteocles and Polynices. The name literally means descendants, successors or heirs, and the second expedition in command of the sons to avenge the first disastrous defeat was thus called the "war of the epigoni." The name is also applied to students who attempt to develop the ideas of the great masters of a previous period.

**EPIGRAM.** The Greek noun from which the word epigram comes was originally used to denote a prose inscription on a temple, tomb, statue, votive-offering to a god or the like. Conciseness and brevity were, therefore, essential qualities. To give pleasure to the ear and help the memory, the Greeks next chose some poetic form for them, preferably the elegiac distich. Their use for practical purposes eventually suggested their composition as a form of literature, with subject matter sometimes wholly imaginary. These poems now often embraced several distichs, and appeared in other metres, but continued to be ordinarily of a simple, expository or descriptive nature. In the Alexandrine period, however, when poets affected almost exclusively short but highly elaborate poems, epigram lost much in simplicity while attaining its highest popularity among the Greeks. Its composition had become the pastime, and even the serious ambition, of authors of first rank, and its recitation and improvisation one of the favorite entertainments at symposia and other social gatherings. Collections of epigraphical epigrams were made. Meleager of Gadara followed these early in the 1st century B.C. with his "Garland" of literary epigrams, the prototype of our Greek Anthology or "Bouquet of Flowers." This numbers about 4,500 poems by over 300 writers in two collections, the Palatine Anthology of Constantinus Cephalas (early 10th A.D.), and that which Planudes made four centuries later, supplying important additions. These collections with countless poetical inscriptions found in modern times constitute for us Greek epigrammatic literature. The Greek Anthology not only throws valuable light on human life from the time of the Persian wars to the age of the Byzantine collectors, but through widespread translation and imitation has deeply affected modern languages and thought. For the names of the prominent writers and a characterization of their work see the special article "Anthology." As a literary genre imported from the Greeks, epigram enters Latin literature with Ennius, but as an inscriptional poem much earlier. Latin is peculiarly adapted to a lapidary, epigrammatic style, and certain racial characteristics, in particular their devotion to the practical, made the Romans natu-

ralize this species of poetry at once. At first they modeled after the Greeks, and we have a few specimens of the erotic epigram as the Alexandrines wrote it. By Cicero's time most of the literary men of importance were writing epigram, and its value as a political weapon was fully appreciated. Catullus is, however, the only writer from whom we have any considerable collection. Although we find in him lyric qualities as fine as in the poems of the Anthology, it is still clear that the national aptitude for satire has already turned epigram strongly in that direction. It is the Latin satiric epigram and not the more lyrical Greek that becomes the model for modern writers. In the Augustan Age, Domitius Marsus and Pedo Albinovanus were, according to Martial, the greatest epigrammatists, but we have not enough of their work to judge it. Martial himself brought this branch of poetry to its acme. None of the eminent poets who followed in his steps, Petronius, Apuleius, Ausonius and Claudian, have equalled him in epigram. In the 6th century Luxorius maintains the tradition, but at a low level. About this time the Salmasian collection was made which forms the nucleus of the modern compilations which we call the Latin Anthology. In the time of Charlemagne epigram enjoyed a veritable renaissance, taking the inscriptional form to describe the material glories of Christianity as well as to sing the praises of the dignitaries of the Church. Then the humanists, to whom Latin was almost a second mother tongue, revived this form once more. But the Latin scholars who have written epigrams are too numerous to name here. One, John Owen of Oxford, should not perhaps be passed by, since he devoted himself wholly to this field and with marked success. In English literature the composition of epigram has long been out of fashion, but for centuries it was popular with literary men. Notable achievements in this line are to be found in the works of Herrick, Johnson, Dryden, Swift, Prior, Addison, Jonson, Goldsmith, Congreve, Hood, Hook, Byron and Burns. Pope's poems might be reckoned a conglomeration of epigrams. Some of the best in our language are by Landon, who cutting loose from the Latin type, at times becomes a Greek in spirit. Epigram has enjoyed wide favor in other modern tongues. In Italy, it long played an important part in politics, as both the Pasquino and Marforio in Rome would testify, could they speak, but it has gradually given way to the madrigal and sonnet. In France from the time of Clément Marot, who introduced it from the Latin, the satiric sort has enjoyed a wonderful popularity. Boileau, J. B. Rousseau, Piron, Lebrun and Chénier have shown its possibilities in many lines. The poetic Priamel of the 14th century may be said to begin epigrammatic literature in Germany, where indeed it has always inclined more to the moral and didactic than in the Latin countries. Among her more eminent epigrammatists are Opitz, Friedrich von Logau who is the best of all, Wernicke Kästner, Klopstock, Lessing, Herder, Schiller and Goethe, who brought out their 'Xenien' together in 1797, Haug, and in more recent times Bodenstedt, Vischer and Fulda. We pass from the history to the theory of epigram. Since it is unlimited in its choice of subject, the form

and not the contents must determine whether a poem is an epigram or not. Lessing has shown much acumen in tracing the essential elements of the epigram in its modern conception to the primitive type, the inscription. Just as a monument arouses in a spectator a curiosity about the author and purpose of its construction, which the inscription then satisfies, so the first part of a literary epigram, whether dealing with some material object, or not, is intended to excite an interest which the close of the poem must duly satisfy. The suspense may be increased by making the prefatory portion of some length. The more remotely separated and apparently contradictory the ideas that are brought together, and the briefer and more unexpected the commentary or explanation at the end, the more successful we deem the poem. This point or conclusion becomes in the satiric epigram a sting. Hence the frequent comparison of an epigram to a bee or wasp. While the above applies to most epigrams as written today, no definition is quite satisfactory with reference to much that the ancients included under the term. Consult Adam, 'Book of Epigrams' (London 1890); Booth, 'Epigrams Ancient and Modern' (2d ed., ib. 1865); Dodd, 'Epigrammatists of Mediaeval and Modern Times' (2d ed., ib. 1875); Watson, 'Epigrams of Art, Life, and Nature' (Liverpool 1884).

WALTON BROOKS MCDANIEL,  
*Assistant Professor of Classical Philology, University of Pennsylvania.*

**EPIGYNY**, ep-ij'i-ni, in flowers, the condition arising when the petals, stamens and sepals appear as coming from the top of the ovary, the latter showing just below the flower. See FLOWER.

**EPIHIPPIUS**, a diminutive horse of the Upper Eocene of Wyoming, in which only the last two premolars had taken on the molar pattern. See HORSE.

**EPILEPSY**. Epilepsy is no longer used as a definite disease name but rather as a symbolic term under which are grouped a great variety of conditions presenting a general resemblance. These are sudden and relatively transient attacks accompanied usually by disturbances of consciousness called variously "faints," "absences," "blanks" and amnesias and convulsive seizures which involve the voluntary and involuntary muscular apparatus.

The historic name epilepsy, the "falling sickness," points to the most evident symptom, the falling due to this loss of muscular control. The strictly etymological origin of the word, literally from the Greek word "to seize upon," also denotes the antiquity of the recognition of this form of disturbance and the ancient animistic character of the hypotheses which sought to explain it, and which has long clung about its mysterious and often violent manifestations. It was recognized in its pure type by the most ancient observers. Hippocrates described it, and evidences are found in the earliest Indian writings of Charaka that the disease was then known.

The most modern belief concerning it is undergoing a process of modification. There is a tendency to speak of "the epilepsies" rather than to consider a disease entity, which fails to

cover the wide range of conditions of which the attacks are but the outward manifestation. The dynamic concept which is making its way into medicine draws attention to the attack as the result of a faulty distribution of energy which may be brought about in various ways and from a variety of far-reaching causes in the constitution and experience of the individual.

The dynamic, energetic concept of the nervous and psychic functioning establishes a working basis by dividing nervous activity into three levels of operation which have been progressively developed according to functional biological needs. Thus the nervous apparatus of man presents the capability of reaction to environment on the physicochemical or purely vegetative level, the sensori-motor and the level which must express itself symbolically as in all the higher psychic forms of reaction. Any one of these levels offers itself as an outlet for the epileptic discharge. The unity of the nervous organism permits the view of it as a mass of interrelated reflexes redistributing the energy bound up with the individual in order to effect his adaptations and his reactions toward his environment, which may thus take place at any one of the three levels. The epileptic inefficiency to so distribute the energy as to bring about a series of harmoniously adjusted activities may in turn emphasize itself in any one of these spheres of discharge.

This accounts for the wide range of manifestations in attacks of the equally extensive underlying conditions. The attacks comprise psychic forms, the so-called functional neuroses and psychoneuroses, the more pronounced psychoses, also toxicemic states, many organic brain diseases and the grosser defects of development, even idiocy. The toxic states may be transitory with removable cause or may be due to defective metabolic functioning which cannot be remedied or to other obscure factors working at the physicochemical level. None of these causes in themselves can any longer be regarded as sufficient explanation of the epileptic form of reaction. The more fundamental conception of a faulty energy distribution indicates a blocking or closing of many paths of outlet either structurally or by psychic inhibition and so accumulation of the discharge within relatively narrow confines. This viewpoint applies thus equally well to the psychic manifestations, the physiological and localized attacks (Jacksonian types) of the physicochemical (tetany).

More accurate and pathological and clinical knowledge tends to separate off from the great epileptic group certain varieties of conditions which can be more definitely identified with other disease groups. There remains, however, for general consideration the still broad and ill-defined "genuine or classical epilepsy" in which the typical reactions are evident for description. The classical major epileptic attack (grand mal) is sudden in onset though preceded often by a warning aura. This may be sensory, motor or purely psychic. At the sudden onset of the attack the patient falls and immediately develops a tonic spasm with unconsciousness. The direction of the patient's fall depends upon the muscles first involved, but in a few moments all the voluntary muscles are affected. Cyanosis results from convulsion of



the respiratory muscles and biting of the tongue from that of the jaw muscles. As the tonic convulsion is succeeded in a few moments by clonic spasms frothy, bloody saliva issues from the mouth and the cyanosis gradually disappears through the return of respiration. Urine is often passed during the attack and less frequently feces. The gradual subsidence of the clonic spasms is followed by a short period of automatic activity after which the patient returns gradually to full consciousness or sinks at once into a deep sleep from which he awakens with lameness and weakness in the muscles which are affected, and perhaps with headache.

The minor attacks (*petit mal*) exhibit an endless procession of variations. The disturbance of consciousness is shorter in duration and less profound and the convulsive phenomena are so mild that they may even escape observation. Occasionally there is a slight convulsion, an involuntary contraction and extension of some of the muscles without loss of consciousness, and the patient resumes his regular course of work or play. In cases of a slight loss of consciousness the patient may suddenly stop in the midst of play or work or conversation, a shade passes over his face and in a moment he is himself again. Sometimes there is a momentary confusion, faltering or fumbling about the clothing in a dazed fashion, which quickly passes over and leaves the patient occupied as if nothing had happened. Occasionally he feels sleepy, lies down for a second and then gets up perfectly well. These attacks may also be preceded by an aura.

Psychic disturbances many and varied may precede or follow the attack or may even replace it. In many subjects there is a marked disturbance sometimes for several days preceding the convulsion, which serves as a warning to those associated with the patient. The manifestations may be increased irritability, complaining, depression or dullness and perhaps also disturbances of the sensory functions, hypochondriacal complaints and hallucinations, all of which conditions are significantly relieved by the convulsion. A condition of active excitement may, however, occur just after the attack, sometimes before, which may reach an actual frenzy, *epileptic furor*. In this state the patient is liable to any act of violence but fortunately the attack is usually brief and moreover the patient's efforts are diffuse and lack coherence.

The so-called *epileptic equivalent* is an attack in which the convulsion is replaced by a purely mental disturbance. The form of attack is frequently that of the *epileptic automatism* or *epileptic dream state*. Almost any act may be committed in these conditions with absolutely no recollection on the part of the patient when he comes to himself. The recognition of this condition is of great importance from a medicolegal standpoint for crimes are sometimes committed and these, if crimes of violence, are often marked by their ferocity and fury. Moreover, the seizure associated with these acts may have been so slight as not to have been noticed. Usually, however, the acts are rather simple and the attacks of short duration. There are also transitory conditions of depression, excitement, confusion, delirium and stupor and peculiarly characteristic one of

ecstasy with hallucinations, particularly of a religious character. There are also transitory states of ill-humor which may be psychical equivalents. These are frequently associated with drinking.

The etiology as well as the prognosis of epilepsy are so involved in the broader concept which avoids the limitation of definitions and unsubstantial formulations that these are best considered also from the energetic standpoint. The genuine epileptic usually comes from a badly tainted ancestral stock, manifesting perhaps not epilepsy in the ancestors or collaterals but evidences of ill-defined nervous disorders. There is evidently a defect of the germ plasm and hence epilepsy and feeble-mindedness are often found associated. This accords with what has been said about the inadequate distribution of energy discharge. There is actual developmental failure to lay down paths for the higher avenues of discharge and constitutional inadequacy to adapt to the demands of environment. The epileptic type of character is apt to be morose, irritable, suspicious and hypochondriacal with resultant unreliability and shallow aggressive religiosity. He is marked by an extreme egocentricity and hypersensitiveness. This, it has been well said, "is not to be taken in any narrow or moralistic sense, but is to be considered . . . in a broad biologic view, a personality-defect which makes its possessor incapable of social adaptation in its best setting and which, if it remain uncorrected, renders the individual entirely inadequate to make a normal adult life. The seizure phenomenon is essential epilepsy . . . constitutes a reaction away from the difficulties in a loss of consciousness."

All the patient's interests centre about the ego. His interests are variable but shallow and easily fall away as they fail to contribute to his egotism or as they present some difficulty which calls for a greater effort without a sufficient egotistic premium. There is always a tendency to turn conversation or any external stimulus to the ego centre. In this as in all his reactions the epileptic manifests the infantile character to a marked degree. His sexuality like his religiosity is of a superficial, infantile, expansive type. The impulses are prominent and easily roused but undeveloped and tending to seek outlet in a number of ways which belong to the infantile polymorphous components of sexuality not yet converged into the adult sexual aim (Freud).

The epileptic state leads in a certain proportion of cases, if it has begun in early life, to conditions of feeble-mindedness, imbecility and idiocy or it has originally been associated with these conditions. It produces in many cases a very profound general mental deterioration. The progress toward this condition as well as the ultimate clinical picture present an accentuated manifestation of the heightened infantile and egocentric character of the epileptic character and reaction. It is associated in a close inter-relation with the superficiality and ready loss of interest. As has been said: "This process . . . consists of a progressive loss of interest associated with a failure of mentation in respect to normal stimuli in which interest is lost. Both loss of interest and intellectual decay proceed from the barely perceptible early stages to total loss of speech

and other acquired functions, when a condition is reached equivalent to the lowest grade of idiocy or the helplessness of a suckling infant." The dementia does not manifest itself in a withdrawal into an hallucinatory world or in the further symbolic activities of other types of dementia. It consists rather in this gradual withdrawal from all contact with environment until a stage of complete infantilism is reached when the individual is merely a biological egocentric entity in the state of supreme infantile dependence and security which characterize the earliest post-embryonic, almost the fetal period. This is also the psychic goal attained temporarily by the attacks which produce profound unconsciousness. Such a conception of the meaning of the tendency and ultimate end of the psychic reaction has been made possible through the psychoanalytic understanding of controlling impulses belonging to the unconscious and determining such reactions. The application of psychoanalytic knowledge and methods to individual cases has led to and confirmed these conclusions and throws a light upon the obscure problems of epilepsy which have so far baffled the neuropathologist and the psychiatrist of older schools. This psychological approach to the problem does not exclude further research along anatomical and pathological lines. On the contrary it awaits accurate and conclusive knowledge which can only come through such exact research and which must form the physiological basis for complete psychological understanding and enlarge the possibility of prophylactic and therapeutic control.

Meanwhile a psychic therapy is proving its efficacy in a more rational understanding of the epileptic constitution and its inadequacy before the demands of life. This brings an explanation of its yielding at points of particular difficulty and utilizing the characteristic modes of energy discharge. It thus affords a prophylactic basis for education and early training to counteract the essential egocentricity and superficiality of interest and in further treatment, whether able to effect a cure or merely to alleviate existing conditions and retard or prevent the ultimate dementia, it stimulates to a sympathetic and watchful interest in the patient in order to meet him at the points of least resistance and rearouse a flagging interest and utilize his very tendencies for counteracting his self-centring. The epileptic colony provides the ideal environment for this course of treatment. The patients are there under the constant supervision of the trained psychotherapist who has this necessary understanding. The variety of occupations provided furnish means for the essential change of interest and the patients are not subjected to a competition which they are constitutionally unable to withstand.

The question of the use of drugs is an important one because of a widespread belief in their efficacy. Bromide is the only one, however, which deserves consideration, being in fact the basis of most of the other remedies offered for this condition. The larger conception of the clinical picture which recognizes the convulsion as not the disease, nor even the cause nor the first expression of it, but only one form of its outward manifestation, an outlet for the accumulated and unutilizable energy, seriously

questions the rationality of bromide medication. Experience seems to show that the convulsion is only postponed, that sooner or later the energy discharge will take place and the drug may indeed in the end produce a summation of attacks which will lead up to that final stage of which the epileptic stands in danger, the condition known as status epilepticus, a terminal stage which consists of repeated and continued convulsive attacks associated with high fever and usually ending in death. It cannot be denied that the bromides have a function in regulating the convulsions when such a danger is imminent but they must be employed with the utmost caution and consideration on the part of the physician. The general observance of hygienic measures is of course of great importance. An outdoor life with a mild, healthful occupation, plain, digestible food, the absence of tobacco, alcohol and other stimulants, a free intestinal canal and surroundings in consonance with the mental capacity of the patient are very desirable features. Treatment during a convulsion is merely protection to prevent injury to the patient. Beyond these measures, however, lies the more comprehensive understanding of the constitutional burden of the epileptic and the very practical aid which this must bring to him in directing and adapting his capacity to the demands of his environment. Consult Jelliffe and White, 'Diseases of the Nervous System' (2d ed., 1917).

SMITH ELY JELLIFFE.

**EPILEPTIC CHILDREN.** See CHILDREN, DEFECTIVE.

**EPILEPTIC COLONIES.** The treatment and care of epileptics in special institutions may be said to be one of the developments of applied philanthropy of distinctly recent origin. By the founding of epileptic colonies is meant the setting apart of distinct tracts of ground for buildings and for the exclusive care and training of epileptics. The position of the epileptic in society is altogether anomalous. As Letchworth well says: "As a child he is an object of solicitude to his parents and guardians. The streets to him are full of dangers, and if sent to school he is apt to have seizures on the way or in the class-room. His attacks shock his classmates and create confusion. He cannot attend church or public entertainments, nor participate in social gatherings with those of his own age and station. In consequence of his infirmity the epileptic grows up in idleness and ignorance, bereft of companionship outside of the family, and friendless. He silently broods over his isolated and helpless condition." The recognition of these truths has caused philanthropists to found such colonies. In continental countries more has been done for epileptics than elsewhere, but in the last 20 years the movement for taking care of this unfortunate class of society has grown to large proportions and, as expressed by Peterson in his presidential address to the National Association for the Treatment and Care of Epileptics 1902, "there is hardly a community in the civilized world that is not now thoroughly aroused to the necessity for the treatment of this class of defectives."

This awakening took place about 1887, and has continued to the present time. The first distinct attempt to provide for epileptics was inaugurated by a Lutheran pastor, Friedrich von

Bodelschwingh, who founded at Bielefeld, in Westphalia, Germany, the Bethel Colony, which, from small beginnings, has grown up to a village inhabited solely by epileptics. Here everything has been provided to meet their special needs, to make up for their deprivations in the outside world. They are supplied with schools to improve their minds, industrial teachers to make them more or less self-supporting, and physicians to study and treat their cases. Outdoor occupations are provided, special diet is arranged for, recreations, amusements, religious instruction, in fact all of the devices that go to make up a home, have been provided under this man's guidance, so that at least nearly 4,000 people, not less than half of whom are epileptics, are being taken care of in Bethel.

The success of the Bielefeld Colony prompted movements elsewhere. Other colonies were founded in Germany and other European countries. Ohio established the first institution for epileptics in the United States, although this was built on the hospital rather than the colony plan. New York has Craig Colony at Sonyea, one of the most elaborate and beautiful institutions of this class, closely modeled on the Bielefeld plan, and accommodating a population of nearly 2,000. Massachusetts has a colony at Palmer; Pennsylvania a colony farm at Oakburn; and there is a New Jersey State village for epileptics at Skillman. A colony for epileptics was established in 1902 at Abilene, Tex., and there are similar establishments in Connecticut, Indiana, Illinois, Kansas, North Carolina, Missouri, Minnesota and California. In England the first colony founded was at Chalfont in 1893 and another at Warford in 1900. There is also a colony, the Waghull Home, near Liverpool; another at Godalming; a large colony at Chelford, and finally a fifth institution was completed 1903-04 for the city of London, not far from Croydon. Other colonies have been founded in Brazil, Belgium, Switzerland, Sweden, Russia, Italy, Turkey, India, Japan and Australia.

The Craig Colony, of Sonyea, N. Y., being one of the most modern and ideal, is selected as a type of this institution. Consult Letchworth. ('Care and Treatment of Epileptics' (1900).

**EPILEPTIC CONSTITUTION.** The epileptic constitution, or makeup, has long been recognized as the mental stigma of essential epilepsy itself. Only recently have studies disclosed that the main tenets of such a character are present years before the nervous disorder of epilepsy, as such, is shown in fits. Indeed, most frequently defects of personality may be detected in earliest childhood. The chief instinctive defects are egocentricity, supersensitiveness and emotional poverty. The potential epileptic is intensively self-centred and fails to project his life interests into his environment in a normal and healthful manner. Partly because of this character-fault, and still more because of his innate inheritance, he is or soon becomes unduly sensitized to all forms of stress and annoying demands. He either extraverts his supersensitiveness by exhibitions of rage and tantrums of a type more severe than those occasionally seen in passionate children, or he introverts this feeling and represses his environmental con-

licts, causing him to develop a very unstable, irritable and sullen emotional life, which paves the way for larger and more difficult adaptations which he cannot meet; outspoken fits may then occur. By possessing an egocentric and supersensitive makeup, the potential epileptic fails to make the degree of environmental contact which would lead him into a broad and rich experience with life, hence sooner or later he fails to acquire a well-rounded emotional development. This deficit may or may not limit the individual's purely intellectual equipment in later life. Previously endowed with the instinctive defects noted, the demands of adolescence and adult life increase the difficulties of such individuals until they reach the breaking point in a fit or seizure. Hand in hand with the handicap of defective endowment occurs a disintegration of habits and character, known as deterioration, which often precedes actual epileptic seizures for a considerable time. This accounts for the fact that an essential epileptic from the very nature of his makeup is usually doomed to mental failure in its broadest sense if proper measures to check or controvert his innate faults are not taken at the earliest possible moment. Any effective plan of treatment must essentially take strict and early account of the makeup of epileptics before all else.

L. PIERCE CLARK, M.D.

**EPILEPTIC PSYCHOSIS.** In the older descriptive neurological concepts, this indicated a mental complex accompanying epilepsy. It was characterized by a certain degree of mental deterioration, as shown in the impairment of intellect and memory, by impulsiveness, mental irritability, loss of moral sense and partial or complete loss of productiveness. It is also accompanied by periodic disturbances, transitory attacks of anger, dream-states or automatic phenomena. Many patents with epileptic attacks do not develop such severe psychoses as to require certification and sequestration, but the mental deterioration may appear at almost any period following the onset of the epilepsy. In many chronic epileptic states there is pronounced weakness, mentally, morally and emotionally. One's sense of one's surroundings is usually preserved, and consciousness may be clear save during the dream-states or automatic periods. Comprehension is usually not markedly impaired, but the field of attention is diminished and easily diverted. Hallucinations are infrequent, illusions are common during an attack or following a grand mal seizure, and delusions are transitory, being found usually only in the dream-states. Morbid and sudden impulses are quite frequent, sometimes approaching distinct nerve-storms, during which suicidal and homicidal attacks may occur. The conduct otherwise is usually orderly, and the ordinary rules of propriety are observed. There is greatly diminished capacity for work in practically all epileptics. The subject of a severe epileptic psychosis is one deserving wide recognition as there are unquestionably a number of phenomena termed "psychical" epilepsy that need recognition by specialists. In some of these attacks the patients are confused. They move in a mechanical or automatic manner. They wander aimlessly about, recognizing no one, although sometimes answering incoherently when addressed. Occasionally they exhibit symptoms

of excitement, at other times depression, and not infrequently they may set fire to their beds or furniture, commit theft, assaults, homicides, expose their persons and otherwise conduct themselves in an irrelevant and insane manner. Treatment is extremely difficult in advanced stages. While younger psychoanalysis and careful endocrinopathic study offer the best chances for modifying the conditions which tend to bring about the epileptic deterioration. The patient should be kept in a sanatorium or asylum. See EPILEPSY.

**EPILOBIUM**, ep-i-lō'bē-ŭm, the willow-herbs, a genus of herbaceous plants belonging to the evening primrose family (*Onagraceæ*). The species are herbs or under-shrubs with pink or purple, rarely yellow, flowers, single in the axils of the leaves, or having terminal leafy spikes. The seeds are tipped with a pencil of silky hairs, and are contained in a long four-celled capsule. There are about 65 species scattered over the Arctic and temperate regions of the world, 40 of them being found in the western and northwestern portions of North America. *E. hirsutum*, or codlins-and-creams, a great hairy willow-herb, is a common and conspicuous plant of waste places in New England and northern New York. Its flowers are pink and rather large, and the whole plant is very downy. Some species are cultivated in America, but these plants are more common in English cottage gardens than in America.

**EPILOGUE** (from the Greek *epi*, upon, and *logos*, word, speech), the closing address to the audience at the end of a play. The epilogue is the opposite of the prologue, or opening address. Many of Shakespeare's plays have an epilogue as well as prologue, in which the poet sometimes craves the indulgence of the spectators for the faults of his piece and the performance, and sometimes intimates in what light his work is to be considered. The epilogue is sometimes a necessary appendage, to tell us something of a composition, which cannot be gathered from the composition itself. In rhetoric an epilogue, when fully developed, repeats the principal points already presented in the composition, and offers an appeal to the feelings of the reader or the audience.

**EPIMENIDES**, ep-i-mēn'īdēz, Cretan philosopher and poet: b. Crete, in the 7th century B.C. By some he is reckoned among the seven wise men, instead of Periander. When the Athenians were visited with war and pestilence, and the oracle declared that they had drawn on themselves the divine anger by the profanation of the temple, in which the followers of Cylon had been put to death, and must expiate their offense, they sent for Epimenides, who was renowned for his wisdom and piety, from Crete, to purify the temple. On his departure he refused to accept any presents, and only asked the friendship of the Athenians on behalf of Cnossus, his home. There is a legend of his having, when a boy, slept in a cavern for 57 years. On awakening, he found, to his astonishment, everything changed in his native town. This story is the ground-work of Goethe's poem, the 'Waking of Epimenides,' for the anniversary of the battle of Leipzig. According to some accounts he is said to have lived for upward of 150, according to others for nearly 300, years. He is supposed to be the

prophet quoted by Saint Paul in Titus i, 12 as saying "The Cretans are always liars, evil beasts, slow bellies."

**EPIMETHEUS**, ep-i-mē'thūs, in Greek mythology, a son of Iapetus and Clymene and the brother of Prometheus. Against the latter's advice he married Pandora, who opened the box in which the foresight of Prometheus had hid all the ills by which mortals were liable to be afflicted. All kinds of diseases and torments issued out of the box and hope alone remained behind. According to other accounts it was Epimetheus himself who opened the box. (See PANDORA). It is to be remarked that, in the Greek tradition, curiosity and disobedience are made the origin of evil, as in the Mosaic account of the fall.

**EPINAL**, ā-pē-nāl', France, town, capital of the department of the Vosges, in a narrow valley on the Moselle 1,070 feet above sea-level, 190 miles (264 by rail) east-southeast of Paris. It has a communal college, a public library of 30,000 volumes, a museum of antiquities and hospital and is surmounted by the ruins of an old castle. The manufactures consist of articles in iron and brass, leather, embroidery print and cotton goods, hats, paper and pottery; freestone and marble are quarried in the vicinity. The town was founded in the 10th century. With Belfort, Dijon and Besançon it forms one of the line of forts along the Moselle. Pop. of commune, 30,042.

**EPINAL GLOSSARY**, a glossary of Old Saxon and Anglo-Saxon, said to date from the 7th century and preserved at Epinal, France. Consult the facsimile published by Sweet (London 1883).

**EPINASTY**, in botany, the rapid growth of a dorsiventral organ on its upper side, which causes it to bend downward to the earth. See GROWTH.

**EPINAY**, ā-pē-nā', Madame de la Live d' (LOUISE FLORENCE PÉTRONILLE TARDIEU D'ES-CLAVELLES), French writer: b. Valenciennes 11 March 1726: d. Paris, 17 April 1783. She was the daughter of M. Tardieu Desclavelles, an officer of high rank, governor of Valenciennes and married her cousin d'Epinau. But his extravagance soon compelled her to separate from him. During the earlier part of her life she formed an acquaintance with Rousseau, who, quick and susceptible in all his feelings, devoted himself to the fascinating and accomplished woman with an ardor, the depth and strength of which he describes himself in his 'Confessions.' She was not insensible to the homage of her "bear," as she used to call him, on account of his eccentricities, and did all that was in her power to place him in a situation corresponding to his wishes. She gave him a cottage (the Hermitage, since so famous) in her park of Chevrette, in the vale of Montmorency. Here the author of the 'Nouvelle Héloïse' passed many days, rendered happy by his romantic attachment to Madame d'Epinau; until he became jealous of Baron Grimm, whom he had himself introduced to her; and in consequence of this feeling, which he took no pains to conceal, a coolness and finally an aversion took place between him and the lady, which is but too plainly expressed in his 'Confessions.' A defense of the later conduct of Madame d'Epinau toward Rousseau may be found in

Grimm's 'Correspondence,' where an account is also given of some works written by her, of which the most celebrated is 'Les Conversations d'Emilie.' In this the authoress, in a rather cold but neat style, sets forth the principles of moral instruction for children, with equal elegance and depth of thought. It obtained, in 1783, the prize offered by Monthion (the chancellor to the Count d'Artois) for useful works of this kind, in preference to the 'Adèle et Théodore' of Madame de Genlis. She also wrote 'Lettres à mon fils,' and 'Mes moments heureux.' An abridgment of her memoirs and correspondence, showing her relations with Duclos, Rousseau, Grimm, Holbach, Lambert, etc., appeared in 1818. They give a true picture of the refined but corrupt manners which prevailed among the higher classes in France during the government of Louis XV.

**Bibliography.**—Beaune, H., 'Scènes de la vie privée au XVIII e Siècle' (1903); Campardon, E., 'Les Prodigalités d'un fermier général' (1882); Fallue, L., 'La Marquise d'Épinay et ses relations dans la vallée de Montmorency avec la société philosophique' (1766); Galiani, L'abbé, 'Correspondance' (1881); Musset-Pathay, 'Anecdotes inédites pour faire suite aux mémoires de Mde. d'Épinay' (1818); Perey, L., and Maugras, G., 'La Jeunesse de Madame d'Épinay' (1883); Rousseau, J. J., 'Confessions'; Sainte-Beuve, 'Causerie du Lundi'; Scherer, E., 'Études sur la littérature contemporaine'; Streckeisen-Moulton, J. J., 'Rousseau, ses amis et ses ennemis' (1865).

**EPIORNIS**, or **AIPYORNIS**, an extinct ratite bird of Madagascar (*Æpyornis maximus*), interesting not only for itself, but because its remains appear to have formed the basis for the Arabic tale of the gigantic roc. It was much like an ostrich in size and structure, except for the massiveness of its limbs and the extraordinary size of its eggs. These have been found in considerable numbers in muck-swamps, or sometimes floating in the river-mouths, often in perfect condition, and are the largest and strongest eggs known, measuring about 13 inches by 9½. These dimensions are twice those of an ostrich's egg, and an egg of the epiornis would hold the contents of six ostrich eggs, yet the epiornis was little if any larger. First made known to science about 1850, so many remains have since been found that about 12 species have been indicated, and a second genus (*Mullerornis*), which has been joined with *Æpyornis* into the family *Æpyornithidæ*. Tradition and the evidences of some bones indicate that these birds were exterminated since human occupation of Madagascar began. See MOA.

**EPIPHANIUS**, ἐπι-φάνι-ūs, Saint, Greek father of the Church: b. of Jewish parents near Eleutheropolis, Palestine, about 315; d. at sea near Cyprus 403. In his youth he went to Egypt where at first he came under the influence of teachers of Gnosticism; but afterward he embraced monasticism, and returning to his own country there became head of a community of monks. In Palestine he made the acquaintance of the two western churchmen, Jerome and his associate, Rufinus; the friendship of the three men was cordial and intimate till Rufinus' defense of the teachings of Origen

angered Epiphanius, whose special mission seemed to be to obliterate every line written by Origen. He was made bishop of Constantia (the older name Salamis), in Cyprus 367, and held that see till his death. On one occasion, 394, he visited Jerusalem to denounce Origenism. He must have been more than 80 years old, perhaps near 90, when he went to Constantinople to charge the patriarch of that see, Saint John Chrysostom, with the sin of favoring the Origenists, but a few words from Chrysostom opened his eyes. His numerous writings are now of little account, his theological polemics being distinguished by fervor rather than by penetration.

**EPIPHANY**, ē-pif'-ā nī, (Latin *epiphania*, appearance or evidence), festival of the Catholic, Anglican and Eastern churches held on 6 January to commemorate the manifestations of Jesus Christ as son of God; (1) to the Wise men of the East (Magi) at Bethlehem; (2) at his baptism by John in the Jordan, when the voice from heaven proclaimed, "Thou art my beloved son in whom I am well pleased"; (3) at the marriage feast at Cana in Galilee, where Jesus wrought his first miracle. The observance of this festival can be traced to an earlier period in the Eastern Church than in the Western. In the Greek Church it was observed as early as the 2d century, but the event commemorated by the Greeks was not the visit of the Magi to Nazareth but the manifestation of Jesus at the Jordan as the Messiah. Not till the 4th century does the Epiphany appear to have been observed in the Latin Church. In the Greek and Oriental churches it is customary to administer baptism on the eve of this festival, with unwonted solemnity. This is said to be because of the relation of the festival to the baptism of Jesus by Saint John. In those churches, too, the Epiphany (Epiphaneia, Theophaneia) was the festival commemorative of the birth of Jesus; for it was believed that the baptism in the Jordan took place precisely on the 30th anniversary of the birth. A popular name for this festival in English is "Twelfth Day," that is, twelfth day from Christmas. It is also called "Little Christmas." In various other languages it is known as "Three Kings' Day," or "Day of the Kings." In the Western Church special attention was paid to the celebration of the adoration of the Magi. This was followed by the celebration of baptism and the miracle of Cana, the latter being held on the succeeding Sunday. In England special holiday celebrations were held on the 12th day and the 12th night when the Christmas festivities closed. Following the provisions of the Council of Nicæa, the date of Easter has long been announced with great solemnity on the 12th night. Connected with the celebration of Epiphany, it was the custom in the Middle Ages and even later, to have sorts of miracle plays in the churches in order thus to visualize to the people the events commemorated on the occasion. These were frequently given during the mass. Similar dramatic representations of a still more popular character were given by the people themselves in their own homes. Performances of this nature, though now generated into popular entertainment, are still to be met with in parts of Germany, Tirol, the mountain districts of Austria and occasionally among the

Christianized Indians and mestizos of Latin America. This dramatic representation generally presented the oblation of the wise men, and fitted it in so that it appeared to form a natural part of the mass. In the traditions of the church the wise men were venerated as the "Three Holy Kings" after which the festival was itself frequently called, being variously designated as *festum trium regum*, *festum magorum*, *festum stellae*. It has long been the custom in the College of the Propaganda at Rome for young men belonging to various foreign nations to represent, by speeches in their native languages, the appearance of Jesus the Christ unto all nations.

There was a tendency in the early days of the Epiphany to connect it with the heathen spring festival, and more especially with the sacrifices and offerings made to the gods of the running waters, in the rivers, the streams and the clouds. Some Christian communities even followed this old pagan custom and blessed the water, the rivers and lakes. This same pagan custom is noticeable in the attempts of certain sections of the Christian Church to make of the Epiphany a special day of baptism, or as it was called *dies luminum*. The Franks, who before their conversion to Christianity, had held special spring ceremonies in honor of the gods of growth and fertility, seem to have been strong supporters of the custom of Epiphany Baptisms. This custom probably corresponded to a spring purification ceremony (by water) common among the Franks and Germanic races in general. The custom of making Epiphany a day of baptism was also strongly clung to in the African Christian Church. The consecrating of the water survived the baptismal and other semi-pagan rites in the Greek Church and is still observed in Russia. The Church connected this baptismal custom with that of the baptism of Christ by John; but it seems not to have become customary until the spread of Christianity into the Frankish and Slave countries where the sacrifices and other ceremonies connected with the deities of growth and fertility were also offered to the gods of water. In explaining this curious blending of pagan religious ceremonies and celebrations with Christian traditional history, Christian writers have asserted that the first baptism of Christ was, in a sense, his real birth, since it was his first manifestation to man. So it was common, in early Christian centuries, to include the ceremony of the commemoration of the birth of Christ in that of Epiphany; and it was only considerably later that the Christian celebration came into vogue. Thus the ancient pagan celebration of the "appearance of the new birth of spring," the purification by water and the celebrations in honor of the occasion, split into separate parts, became two of the greatest festivals in the Christian Church, and have continued to maintain their position as such to the present day.

It is probable that the custom of presents from the wise men to the infant Jesus arose out of the practice of presenting offerings to the gods of nature and growth at the spring festival, and also of a similar custom in vogue among the Roman people who made presents to one another on this occasion. The fact that Epiphany is one of the oldest ceremonies in the Christian Church, having already been

established by the time of Clement of Alexandria, who lived in the latter half of the 2d and the early part of the 3d centuries, would seem to indicate that it was the survival of earlier customs and ceremonies; since, even at this early date, there was some considerable speculation as to its origin. See MAGI.

**Bibliography.**—Bingham, R., 'Antiquities' (London 1834); Blumenbach, H., 'Antiquitates Epephamorum' (Leipzig 1773); Chambers, 'Book of Dates' (London 1864); Herzog, 'Real-Encyclopädie'; Jacoby, A., 'Bericht ueber die Taufe Jesus' (Strassburg 1902); Kellner, K. A. H., 'Heortologie' (Freiburg 1906); Nazianz, G., 'Tesaurus' (Antwerp 1869); Schutze, J. L. D., 'De festo Sanctorum Luminum' (Leipzig 1841).

JOHN HUBERT CORNYN,  
*Editorial Staff of The Americana.*

**EPIPHYLLUM**, ĕp-ĭ-fĭl'ŭm, a genus of plants of the natural order *Cactaceae*. The few species seem to be confined to Brazil, where they are epiphytic upon trees. They have flat-jointed stems with blunt ends, from which the new branches and flowers are produced. These are borne in great abundance, on which account, and because of their brilliant red tints, this group of cacti is exceptionally popular in greenhouses, being probably the most useful of all cacti. They are easily propagated by means of cuttings or by grafting, particularly upon erect-growing species of other genera, and are generally used as hanging-basket plants, for which purpose their drooping habit specially recommends them. They need a porous, poor, fibrous soil and little water. The species most widely grown are *E. truncatum*, the crab or Christmas cactus, with numerous horticultural hybrids between it and related species, and *C. Gartneri*, the Easter cactus.

**EPIPHYSIS.** See BONE.

**EPIPHYTE**, ĕp-ĭ-fĭt, or **AIR-PLANT**, a plant attached to a tree or other support, organic or inorganic, living or dead, but from which it obtains no nutriment. The term air-plant has been popularly applied because these plants are typically neither parasitic, saprophytic nor terrestrial, but depend upon the dust which lodges around them and upon the water of dew and rain. Strictly speaking, they are not air-plants, because this term implies no other source of life than air. Besides the typical epiphytes, which have representatives in many plant families, particularly the tropical orchids, bromelias and ferns, there are many forms which are only partially epiphytic. In structure many of them exhibit adaptations for checking transpiration and for securing even minute quantities of water from the air or from objects to which they are attached. (See PITCHER-PLANTS). Others (certain orchids) have storage organs which are usually specialized stems. Some have roots which serve only to anchor the plants to their support. In these, which are the most typical, the absorption of food takes place in the leaves and other green parts. Others are only epiphytic at first, since they later develop true roots which obtain food from the soil. The home of the largest number of epiphytes is in the moist region covered by tropical forests, the trees of which are often so covered with these plants that their branches are wholly concealed by a very miscellaneous growth. In the temperate

and colder climates the epiphytal forms are confined almost wholly to lower orders of plant life such as liverworts, mosses, algæ and lichens. These are also represented in the tropics, some of them even becoming attached to leaves of higher plants. Many of the flowering epiphytes are cultivated in greenhouses for ornament. Among the favorites are various species of *Nepenthes* (q.v.), orchids and bromelias. One of the best-known American species, common in the southern United States, is the so-called Florida or Spanish moss (*Tillandsia usneoides*) of the natural order *Bromeliaceæ*.

**EPIRUS**, ē-pī'rūs (meaning the mainland in Greek), an ancient part of northern Greece which stretched from the Ionian Sea to the Ambracian Gulf and was bounded by Illyria, Macedonia and Thessaly. Epirus is very mountainous, especially so in the east, and this fact undoubtedly helped to shape the character of the inhabitants, who were of a bold and hardy nature and great lovers of their country, which was divided into numerous independent tribes, the principal of which were the Chaones, Molossi and Thesproti. The Greeks began early to settle along the coast of Epirus, and later, at some interior points. This led the way to Greek domination of the country at a later date. The chiefs of the Molossians, the most powerful of the tribes of Epirus, who claimed to be the direct descendants of Pyrrhus, the son of Achilles, whom legend credited with settling the country after the fall of Troy, and who consequently prided themselves on a long line of princely ancestors, jealously maintained their ascendancy and gradually increased their power over the whole country. Arymbas I of this line, who was educated in Athens, introduced Greek culture among his people during the second quarter of the 5th century B.C.; Arymbas, a century and a half later, followed in the footsteps of his famous ancestor and namesake, and sedulously encouraged art and literature. One of his nieces, educated carefully by him and married to Philip II of Macedonia, was the mother of Alexander the Great. A period of wars followed the death of Arymbas II, interrupted from time to time. Pyrrhus, who succeeded to the throne in 295 B.C., carried the war to the Romans in Sicily and Italy for six years, and brought the name of Epirus prominently to the attention of the Greek and Roman world. Finally Epirus became a sort of republic governed by a magistrate elected annually by the vote of the assembled people. The country unwisely sided with Perseus in his war against the Romans (168 B.C.). The latter exacted a terrible retribution, making slaves of 150,000 inhabitants of Epirus after having destroyed 70 towns and villages; and 22 years later the whole country became a political part of Macedonia under the title of Epirus Vetus. On the fall of Constantinople (1204) it was seized by Michel Angelus Comnenus. Later, after passing through several hands, it became the property of the Turks (1430); and it later formed part of the Turkish Vilayet of Janina. Greece obtained the part east of the river Arta in 1881.

At the close of the Balkan War (1912-13) Greece added a new province to her territory on her northwest, and to this she gave the name of Epirus. This province is bordered on the north by Albania, on the east by the provinces

of Macedonia and Thessaly, and on the south and west by the Gulf of Arta and the Ionian Sea. The population of this newly-acquired territory is between 600,000 and 700,000 and its capital is Janina, a city of 25,000. It is largely an agricultural country and among its chief products are wheat and other grains, olives, fruits, vegetables and tobacco.

**Bibliography.**—Bowen, 'Mount Athos, Thessaly and Epirus' (London 1852); Dumont, 'Souvenirs de l'Adriatique et de l'Épire' (in *Revue des deux Mondes*, Paris 1872); Hobhouse, 'A Journey through Albania, etc.' (London 1813); Karapanos, 'Dodone et ses Ruines' (Paris 1878); Leake, 'Travels in Northern Greece' (London 1835); Merleker, 'Darstellung des Landes und der Bewohner von Epeiros' (Königsberg 1841); Skene, 'Remarkable Localities on the Coast of Epirus' (in *Journal Royal Geographical Society* 1848); Stuart, 'Physical Geography and Natural Resources of Epirus' (1869); Von Hahn, 'Albanesische Studien' (Jena 1854); Wolfe, 'Observations on the Gulf of Arta' (in *Journal Royal Geographical Society* 1834); Zompolides, 'Das Land und die Bewohner von Epirus' (Berlin 1880).

**EPISCOPACY**, that form of Church government in which one order of the clergy is superior to another; as bishops to priests and deacons. Much discussion has taken place on the subject of episcopacy. Nothing conclusive can be gathered concerning it in the New Testament; but there can be no doubt that it existed universally in the Church from the earliest historic ages down to the time of the Reformation, and it is inferred, as no change can be shown to have taken place, that the same constitution existed from the time of the apostles. Presbyterians and others argue, on the other hand, that, as there is nothing definite concerning it in Scripture, Christians are left a discretionary power of modeling the government of their Church in such a manner as may seem to them most meet; and that every Christian society has a right to make laws for itself, provided these laws are consistent with charity and peace and with the fundamental doctrines and principles of Christianity. The power vested in the bishops or higher clergy differs very much among the different episcopal bodies. The Roman Catholic and the Greek Churches, as also the Church of England and sections of the Methodist Church, are episcopalian. See BISHOP; GREAT BRITAIN — THE CHURCH OF ENGLAND; GREEK CHURCH; METHODIST EPISCOPAL CHURCH; CATHOLIC CHURCH, ROMAN.

**EPISCOPAL CHURCH.** See GREAT BRITAIN — THE CHURCH OF ENGLAND; METHODIST EPISCOPAL CHURCH; PROTESTANT EPISCOPAL CHURCH; REFORMED EPISCOPAL CHURCH.

**EPISCOPAL CHURCH, Reformed.** See REFORMED EPISCOPAL CHURCH.

**EPISCOPAL RING, The.** See COSTUME, ECCLESIASTICAL.

**EPISCOPAL THEOLOGICAL SCHOOL**, an institution situated at Cambridge, Mass. It was established in 1867 by Benjamin Tyler Reed, as a college for candidates studying for the ministry for the Episcopal Church. Students holding bachelors' degrees may obtain the degree of B.D., but those not holding such a degree receive only certificates. The principal

buildings include the chapel, the deanery, the library and Reed, Burnham, Lawrence and Winthrop halls. The students number about 60. The school is affiliated with Harvard University.

**EPISCOPIUS** (a translation of Bisschop, his Dutch name), **Simon**, Dutch theologian: b. Amsterdam, 1 Jan. 1583; d. there, 4 April 1643. The religious movement known as Arminianism was fostered by him, and he was its leader after the death of Arminius (q.v.). He was educated at Leyden, where in 1606 he received his degree of M.A. In 1610 he was ordained pastor at the village of Bleyswyck near Rotterdam. In 1611 the States-General, with the intention of putting an end to the agitations created by the controversies between the Gomarists or Calvinistic party and the Arminians or Remonstrants, ordered a conference to be held in their presence at The Hague between six ministers of each party. Episcopus was one of the six charged with the advocacy of Arminianism, and highly distinguished himself by good temper, ability and learning. In 1612 the curators of the University of Leyden appointed him professor of theology in place of Gomar, who had gone to Seeland. This enraged the leaders of the orthodox party, who accused Episcopus of Socinianism and of having entered into an alliance with the Roman Catholics for the destruction of Protestantism. By this the fanaticism of the populace was roused; he was insulted and abused in the street, and on one occasion narrowly escaped being stoned to death. The house of his brother in Amsterdam was sacked, under the pretext that it was a rendezvous of the Remonstrants. In 1618 occurred the famous Synod of Dort. Episcopus was present, with several other Arminians. The Calvinists, who were in an overwhelming majority, would not allow him to speak; they told him that the synod was met not to discuss, but to judge; and all the proceedings exhibited much bigotry and tyranny. Expelled from the Church and banished from the country, Episcopus betook himself first to Antwerp, afterward to Rouen and Paris, but 1626 returned to Rotterdam, where the *odium theologicum* against his party had become less virulent. Here he married in 1630, and four years later was made primarius professor of divinity in the newly established college of the Remonstrants. Episcopus held enlightened principles in regard to religious toleration. Not placing a high value on merely doctrinal views, but trusting rather to the efficacy of the Christian spirit to elevate and purify the character, and seeing, moreover, the presence of this spirit in men holding the most conflicting opinions (when not inflamed with controversial hates), he was desirous of a broader and more catholic bond of unity among Christians than the opinionative creeds of his day permitted. He wrote 'Institutes of Theology'; 'Apology'; 'Confession.' (See GOMARUS; ARMINIUS). Consult Calder, 'Memoirs of Simon Episcopus' (London 1838).

**EPISODE** (Lat. *episodium*, from the Gr. *ἐπεισόδιον*, *epesiodion*, something adventitious), a separate incident, story or action introduced into the general narrative, to give variety or digression, but so arranged as to appear a part of the whole. This term is employed by Aristotle in two significations. Sometimes it denotes those parts of a play which are between the

choruses, and sometimes an incidental narrative, or digression in a poem, which the poet has connected with the main plot, but which is not essential to it. In modern times it has been used in the latter sense only. With the best poets the episode is not an unnecessary appendage, serving merely to swell the size of the work, but is closely connected with the subject, points out important consequences or develops hidden causes. Of this kind is the narrative of the destruction of Troy, in Virgil's *Æneid*. This was the cause of the hero's leaving his country; but the poet does not commence with it because he wishes to bring the plot into a narrower space. He therefore inserts it in the course of the story, but so skilfully that we expect it in this very place; and it not only serves as a key to what has gone before, but prepares us for what is to come, namely, the passion of Dido. In this way the episode becomes an essential part of the whole, as it must necessarily be, if it is of any importance to preserve the unity of the poem. So with the tale in Wieland's 'Oberon'; it appears incidental, but explains to us the reason of Oberon's singular interest in the fate of Huon. In epic poetry there is much more room for the episode than in dramatic, where the poem is confined to a present action. An excellent instance of the skilful use of the episode in the modern novel is given in Manzoni's 'I promessi sposi,' in the tale of the 'Nun of Monza.' The term episode has also been transferred to painting, especially historic painting, in a sense analogous to that which it has in poetry. The term episode is also employed in music to designate an intermediate section of a composition. The term is also applied to a digressive section, especially in contrapuntal work, like a fugue.

**EPISTATES**, in ancient Greece, the name generally applied to an officer in charge of certain functions and specifically to the presiding officers of the *Ekklesia* and the *Boule* or Senate.

**EPISTAXIS**. See NOSEBLEED.

**EPISTEMOLOGY** (*ἐπιστημολογία*, knowledge or science, and *λόγος* theory or discourse), or theory of knowledge, is an account of the nature of knowledge, treating of its origin and laws of development, its validity and relation to human experience as a whole. Investigations of this character fall within the field of general philosophy and have usually been included under the heading of metaphysics. The word "Epistemology" is said to have been first used by J. F. Ferrier in his 'Institutes of Metaphysics' (1854). Since its general adoption it has sometimes been taken to denote a field of inquiry co-ordinate with, and largely independent of, Metaphysics. It has been proposed to keep the investigation of the nature of knowledge distinct from the problems regarding the nature of being, and to call the former epistemology, and the latter metaphysics. The best usage of the present time, however, seems to retain the historical sense of the term metaphysics as the name for the more general field of philosophical inquiry which embraces both epistemology and ontology. (See also articles on PHILOSOPHY and METAPHYSICS). Moreover, a logical justification for this usage is furnished by the fact that it is impossible to carry on the two branches of inquiry in isolation. It must un-



doubtedly be granted that for an ultimate ontology, or final view of the world, it is necessary to go beyond the merely cognitional aspect of experience and include in our synthesis judgments based on other orders of value than the merely logical. But it is at once obvious that we cannot take one significant step in investigating the nature of reality without some criterion of knowledge, i.e., some theory of the conditions under which reality is known, and of what constitutes truth. It is perhaps not so evident that the nature of knowledge cannot be made the subject of inquiry without any reference to metaphysical theory. Indeed, it is not uncommon to speak of epistemology, as Locke does, as "a preliminary clearing of the ground" which is to be completed before any more ultimate metaphysical inquiries are to be undertaken,—if, indeed, these are to be undertaken at all. But this way of conceiving the matter is quite misleading. The figures which compare the knowing faculty to an instrument whose nature must first be understood, are here quite inapplicable. For knowledge has no existence by itself, or apart from and external to its objects. What we want, as Hegel has observed, "is to combine in our process of inquiry the action of the forms of thought with a criticism of them. The forms of thought must be studied in their essential nature and complete development; they are at once the object of research and the action of that object. Hence they examine themselves; in their own action they must determine their limits and point out their defects." In other words, knowledge is never a mere series of ideas or mental representations that can be investigated apart from its relation to objects. In so far as it is knowledge it refers to and implies reality. To investigate its nature, then, is at the same time to test its conclusions regarding the nature of the objects with which it deals. But even if one refuses to take this standpoint, one must still admit the close connection of epistemology and metaphysics. For all theories of the nature of knowledge are based implicitly or explicitly on certain metaphysical assumptions regarding both the mind which knows and its relation to the objects known. Epistemology, then, cannot take one step without involving the ontological problems which some of its representatives seek to avoid.

It is likewise impossible to distinguish sharply the discussion of epistemological problems from logic. If a division can be made at the present time it is only in degree of ultimateness. It is possible, though perhaps not advisable, to limit the term "logic" to the somewhat narrow and abstract treatment which takes as its object the discovery of certain correct forms of thinking, or certain rules which are of practical value in testing arguments. When, however, logic breaks away from this narrow program, as has been done by the more important recent writers, and carries on its inquiries in a philosophical spirit, it becomes identical with epistemology. Epistemology, logic, and metaphysics may thus be said to denote certain main points of view, differing somewhat in the treatment of various writers in emphasis and inclusiveness, rather than three independent and isolated sciences.

Psychology, as a natural science, however,

occupies a different field, and has quite a different problem from epistemology. It is true that attempts have frequently been made to explain knowledge by beginning with cognitive mental states viewed as psychological processes. But the characteristics of the mental states and functions with which psychology deals have no immediate bearing on the problem of knowledge. For psychology is concerned only with the mode in which ideas exist; it investigates their quality, duration, intensity, etc., as well as their various modes of combination, viewing them as particular forms of psychical reality. Epistemology, on the other hand, is interested not in the existential aspect of ideas, but in their significance, in the universal and objective validity of experience as a body of truth. It thus seeks to bring to light the forms and functions of intelligence, noting the conditions and presuppositions under which it works, and the laws by which knowledge develops from its simpler and more fragmentary stages to the more complicated and coherent structure of science. It is a philosophy of experience rather than a description of individual states of consciousness.

Reflection on the nature of knowledge does not arise until a somewhat late stage in the development of the thought of the individual and the race. Thought first announces its conclusions confidently and fearlessly. It is not until this naive confidence fails and scepticism arises that it is forced to reflect upon the nature of knowledge and its grounds of certainty. This is illustrated in the history both of ancient and of modern philosophy. The early Greek philosophers, as Hegel remarked, thought away fearlessly regarding the nature of reality. It was the collapse of those early systems and the scepticism of the Sophists (q.v.) which forced Socrates to take up the epistemological problem. In the same way the Stoic and Epicurean discussions regarding the canon of truth arose in response to the more outspoken and thorough-going scepticism of later times. In modern times the epistemological interest did not come into the foreground until Locke's 'Essay.' Locke's account of the origin of this work brings out very clearly the way in which problems of this character naturally arise: "Five or six friends meeting at my chamber, and discoursing on a subject very remote from this, found themselves quickly at a stand by the difficulties that rose on every side. After we had awhile puzzled ourselves, without coming any nearer a resolution of those doubts which perplexed us, it came into my thoughts that we took a wrong course, and that before we set ourselves upon inquiries of that nature, it was necessary to examine our own abilities and see what objects our understandings were, or were not fitted to deal with . . . . Some hasty and undigested thoughts on a subject I had never before considered, which I set down against our next meeting, gave the first entrance into this discourse; . . . and at last it was brought into that order thou now seeest it."

Kant's 'Kritik of Pure Reason' was the work which placed epistemology in the foreground of continental philosophy. In the Preface to that work, he showed that the motives that led to his undertaking were very similar

to those which influenced Locke. The scepticism of his time, he says, "is clearly the result, not of the carelessness, but of the matured judgment of an age, which will no longer rest satisfied with the mere appearance of knowledge. It is, at the same time, a powerful appeal to reason to undertake anew the most difficult of its duties, namely, self-knowledge, and to institute a court of appeal which should protect the just rights of reason, but dismiss all groundless claims, and should do this not by means of irresponsible decrees, but according to the eternal and unalterable laws of reason." Kant has a poor opinion of Locke's account of knowledge, and characterizes it as "a certain physiology of the human understanding." He himself proposed to inaugurate a method of Criticism which should give a new direction to philosophical inquiry, and at the same time furnish to it a sure foundation for further advance. Since Kant's time epistemological problems have largely dominated modern philosophy; and indeed, it has been maintained by many thinkers that the criticism of knowledge is the sole function which philosophy is able to perform, and that ontological speculation is vain and fruitless.

In the Pre-Kantian philosophy Rationalism (q.v.) and Empiricism (q.v.) were the main types of epistemological theory. The basis of the former was laid by Descartes (q.v.), who sought to universalize the method of mathematics, and by this means to secure the certainty of absolute demonstration in all fields. As mathematics start from axioms and principles which are intuitively certain, and proceeds by means of reasoning to deduce all its other propositions from these as necessary consequences, so all science must derive its conclusions from fundamental and indemonstrable principles. These principles exist in the mind as *a priori* truths, and are universal and necessary in character. All science is thus built up by reasoning from general principles. Sense-perception and observation of particular facts were neglected, since it was held to be impossible to arrive in this way at the universal and necessary form of truth which science demands. It is evident that this theory of knowledge could more readily be applied to the general features of reality than to a determination of its particular details. As in the hands of Wolff (q.v.) and other continental rationalists it was occupied mainly in furnishing formal proofs of the existence of God, the nature of the soul, and the external features of the physical universe. Empiricism (q.v.), on the other hand, emphasizes sense-perception as the basis of all knowledge. Experience is described as a series of particular sensations and ideas in consciousness which are given to the mind from some external source. The mind itself is regarded as merely receptive, without any store of innate ideas, or of organizing principles. It was not strange, then, that in the hands of a genius like David Hume (q.v.), who carried this point of view to its logical outcome, empiricism should issue in scepticism. For if experience is nothing but a series of conscious states, each of which is "loose and separate" from all the others; it is impossible to know anything except these particular states in their isola-

tion; impossible, therefore, to reach any universal propositions such as science demands. Again, if knowledge is limited to states of consciousness, it follows at once that there can be nothing known either of the nature of objects or of the subject or soul.

Kant (q.v.) did much to overcome the one-sidedness of these theories, and to give a more adequate account of the nature of knowledge. For, while he insists that knowledge must begin with experience, he points out that experience itself is a compound, implying both a given sense material and forms and principles of organization on the part of the mind. By his doctrine that "thoughts without perceptions are empty, while perceptions without thoughts are blind," he passed beyond the one-sided views of both Rationalism and Empiricism. By his transcendental method of inquiry he seeks to show what are the fundamental forms and categories which the mind employs in building up a coherent and universally valid system of experience. But, in spite of the great reform which he effected, he did not wholly succeed in reaching an organic view of experience. This was partly the result of presupposition which he inherited from the past, and partly due to his own tendency to make hard and fast divisions and distinctions. There always remained for him an unresolved dualism within experience between the datum of sense and the forms of thought. Again, thought, as he conceives it, does not pass beyond subjectivity and include in itself the nature of its object, but is occupied with bringing order and unity into sensations and mental representations. Although these states of consciousness, when thus acted upon by thought become objective in the sense that they are parts of a universal and necessary system, nevertheless they are still only "phenomena," objects in the mind, while the world of real being (the things in themselves) remain inaccessible to knowledge. The spirit of Kant's philosophy undoubtedly leads beyond any such absolute dualism. But from Kant's day to the present time this distinction has appeared the final word of philosophy to many thinkers who continue to accept the presuppositions and categories of the past century, and who fail to apply to this problem the organic and evolutionary conceptions which are now within their reach.

Modern epistemological investigation may be described as seeking to exhibit the organic unity of experience. To reach this result, new theories regarding the nature of the mind and its relation to objects are necessary. In the first place, the conception of the mind as made up of a number of distinct faculties must give place to the idea of the mind as a unitary system of functions which mutually co-operate and determine each other in the progressive development of experience. Secondly, the mind can no longer be regarded as a system of merely subjective functions related only in an external and accidental way to the real world of objects. The course of philosophical discussion has rendered it evident that if we begin by defining experience in terms of mental processes there is no way of deriving from these the world of objects. If our epistemological theory is to be adequate to experience as we know it, objectivity must be included within it. Thought, that is, is real only as a relation

to objects; by itself, and apart from the world of real objects, it has no reality. It is only by thus recognizing from the beginning the essential relation of subject and object that it is possible to exhibit the real organic unity of experience as a system of knowledge. It was Kant's successors in Germany, and pre-eminently Hegel (q.v.), who first developed this organic view of experience. But partly on account of the form in which these systems were expressed, and partly as a result of the decline of philosophical interest, their most valuable and characteristic ideas failed for a long time to be appreciated. The credit of freeing these fruitful ideas from the somewhat obscure and uninviting form in which they were presented in the German systems of a century ago, belongs in the main to the English neo-Hegelians and their co-laborers in America, among the latter of whom a place of honor must be given to Dr. William T. Harris, the late United States Commissioner of Education. The fundamental doctrine of these writers is that what is real is rational, i.e., knowable in terms of reason, and therefore that all forms of cognitive experience can be exhibited as organically interconnected as a system of rational ideas or meanings. Conscious experience is from the first regarded, not as a series of psychological states, but as taking the form of a judging activity whose function is to interpret and reveal the nature of the objective world. Moreover, knowledge proceeds in its development through differentiation and integration in accordance with the fundamental laws of logical evolution. Its later and more highly developed forms are then to be understood as the differentiation and systematization of its more elementary forms and functions. The final truth regarding the nature of the real world must accordingly correspond with the ideal of completely developed and perfectly rationalized experience. As representatives of this general type of objective Idealism we may mention the late T. H. Green, Edward Caird, the late D. G. Ritchie, A. S. Pringle-Pattison, B. Bosanquet, W. T. Harris, John Watson and Josiah Royce.

There are, however, prominent philosophical writers of the present day who employ to some extent Hegelian methods and principles in dealing with experience, but who yet maintain that the account of knowledge in terms of reason requires to be modified and supplemented in various ways. Two main points of view may be here mentioned, which have much in common, and which are both often emphasized by the same writers. On the one hand, it is claimed that logical thinking operates with universal concepts, and can therefore never do justice to the individual aspects of real objects. Thought, in other words, is concerned only with universal relations, and is unable to apprehend the uniqueness and particularity of real existence; it gives us only descriptions of things in general terms, and has to receive as a datum from another form of knowing the particular facts which form its subject-matter. This latter aspect of reality, it is maintained, can be apprehended only in some form of immediate experience. In fact, it is often maintained that logical experience must both start from and pass into direct intuition or feeling. In its beginning,

logical thinking presupposes the awareness of objects in sense-perception; for it is claimed it is only in this way that thought comes into contact with individual things and gets a foothold in reality. Again, since the total system of things must exist in individual form, the final synthesis of knowledge must transcend logical relations and be realized, if it can be attained at all, in immediate intuition—a mode of cognition that may perhaps be described as analogous to æsthetic contemplation. Although the neo-Hegelian writers have not been backward in meeting these arguments, and have successfully shown the difficulties involved in their opponents' antithesis of universal and individual, of thought and immediate knowing, yet the discussion cannot be regarded as closed at the present time.

In a similar spirit the function of will and purpose as a fundamental element in experience is at present emphasized in many quarters. The intellectual or rationalistic account of cognitive experience is maintained to be inadequate, since it abstracts from the volitional element which alone gives to knowledge its function and significance. Concrete experience is the process of living, and living consists in the realization of purposes. So much may, I think, be granted: experience is essentially a teleological process and must be interpreted in terms of purpose. But purposes are only defined and realized through thought. Pragmatism (q.v.) (as the popular theory of the present day is called) goes further, and interprets knowledge solely in its relation to action. Knowledge is the instrument which the will employs to discover the means whereby practical purposes may be realized. It is thus never an end in itself, nor does its function consist in revealing the nature of a reality beyond experience. The function of thought is to effect the practical control of experience, and the only realities which it can define are terms within experience itself. Its problems are set by the particular situations and concrete demands which the developing process of experience presents. There is no intelligible problem regarding the nature of reality in general, or reality that does not exist as a particular functional element in concrete experience. Against this position various objections have been urged by many writers; the chief of which are (1) that it does not reach a real organic unity of experience; (2) that it overlooks the fact that knowledge is an end in itself; (3) that it is subjective, and fails to recognize the objective and rational ends without which no real experience can exist.

At the present time perhaps the most important function of Epistemology consists in a criticism and evaluation of the fundamental conceptions and principles which underlie the procedure of the special sciences. These sciences set out from certain definite assumptions regarding the nature of the phenomena which they investigate, and with certain demands which their method of investigation has to fulfill. It is the function of Epistemology to make explicit the nature of these initial assumptions, and to show that the accounts given by these sciences are essentially determined by the character of these assumptions. Instead of assuming that the results of the

special sciences are to be accepted at their face value as direct statements about the nature of reality, both philosophical epistemologists and workers in these sciences who have reflected on the problems of method (as e.g., E. Mach and Karl Pearson) now agree that the view of the world given by natural science—and especially the mechanical theory—is itself a logical construction, based on certain assumptions which are necessary to carry out the purpose of the scientific co-ordination and explanation of facts. This construction must not be read apart from the purpose for which it was designed. Indeed, the prevailing tendency is to emphasize the merely methodological character of scientific results to such an extent as to make them appear almost arbitrary and devoid of any ontological significance. This is undoubtedly an extreme position. It must, of course, be admitted that the results of the special sciences are largely hypothetical and possess only relative truth. But they are never mere logical constructions in the sense that they are entirely divorced from reality. The ultimate purpose of science, as of all thinking, is to exhibit the structure of the real world, and the assumptions and hypotheses of the special sciences derive their significance and justification solely from their employment as means for the accomplishment of that end. In its task of criticizing the assumptions of the special sciences, then Epistemology cannot escape the consideration of metaphysical problems regarding the nature of the external world and its relation to the human mind.

**Bibliography.**—The bibliography of this subject is coextensive with that of general philosophy. A few works may be mentioned which deal with the more recent development of the subject: Albee, 'The Significance of Methodological Principles' (in *Philosophical Review*, Vol. XV, 1906); Bergson, Henri, 'Creative Evolution' (Eng. trans., New York 1911); Creighton, James E., 'Methodology and Truth' (in *Philosophical Review*, Vol. X, 1901); Dewey, 'Studies in Logical Theory' (Chicago 1902); id., 'The Influence of Darwin on Philosophy' (New York 1910); James, 'Pragmatism' (ib. 1907); id., 'The Meaning of Truth' (ib. 1909); id., 'Essays in Radical Empiricism' (ib. 1912); 'The Will to Believe' (ib. 1909); Ladd, 'Philosophy of Knowledge'; Marvin, 'The New Realism' (New York 1912); Münsterberg, 'Psychology and Life'; id., 'Grundzüge der Psychologie'; Ormond, 'Foundations of Knowledge' (1894); Rickert, 'Die Grenzen der Naturwissenschaftlichen Begriffsbildung' (1902); Seth, 'Epistemology and Metaphysics'; id., 'Problem of Epistemology' (in *Philosophical Review*, Vol. I, 1892); Ward, 'Naturalism and Agnosticism.'

JAMES E. CREIGHTON,

Professor of Logic and Metaphysics, Cornell University.

**EPISTLE TO ARBUTHNOT.** Pope's 'Epistle to Arbuthnot' (1734-35), known also as 'The Prologue to the Satires,' is quite the best thing of its kind in English. Characteristic of the writer in its invective, its brilliant wit, its epigrams and apothegms, and its incisive and compressed style, it is far more than any other of his satires a key to the character of the man

himself. Indeed, it presents an entire autobiography in little more than 400 lines. It is Pope's *apologia*, in which he disproves the statement that he was of lowly birth, tells how and when he entered upon his profession as poet, relates his persecution by literary pretenders and bores; dwells especially upon the slanderous attacks by his enemies; and draws portraits of his enemies and his friends. The whole is a mélange of personal confession and of satire to which unity is given only by the personality of the poet and by his interest in himself. So highly autobiographical and allusive is the 'Epistle' that a commentator is needed to point out its full significance. Quite apart from any autobiographic element, however, it is intrinsically great among its kind, and even to the reader who knows little of Pope's character and disregards the contemporary allusions, is still immensely entertaining. As Sir Leslie Stephen has remarked, Pope is at his best when he expresses personal antipathies and attachments, when he is autobiographic, and when he points his morality by personal and concrete instances. He was a curious mixture of honesty and hypocrisy, though often honestly self-deceived, and certain passages of the 'Epistle' must "be read by the rule of contraries." Yet there is no more reason to doubt the sincerity of his tender tributes to his mother and to his friend Arbuthnot than his vitriolic lines on Lord Hervey (Sporus). Though of various tones, the 'Epistle' is in the main bitterly satirical. The original cause of the entire series of Pope's apologetic satires was his 'Dunciad,' which provoked violent counter attacks. The immediate cause for the composition of the 'Epistle,' however, was the publication in 1733 of 'Verses to the Imitator of Horace,' which attacked the family, the person, the manners and the morals of the poet, and in which Lady Mary Wortley Montague and Lord Hervey were implicated. Characteristically, Pope pretended to be indifferent to the attack, and in his "advertisement" asserts that the 'Epistle' was composed long before the appearance of the Montague-Hervey volume. The statement is disingenuous, since only 96 lines (151-214, on Addison; 238-241, on Bufo; 406-419, on Arbuthnot) were old matter. These disconnected passages were pieced together and over 300 lines added to form the brilliant and scathing rejoinder to 'Verses to the Imitator of Horace.'

Dr. Johnson traces the idea of the 'Epistle' to Boileau's address 'A son esprit,' but, though Boileau's poem is admirable, Pope far excels it. "The sustained dramatic power, the variety of the detail, the richness of the imagery, the elevation of the sentiment, the force of the invective, contrasting so exquisitely with the pathetic repose of the conclusion, combine to place the 'Epistle' beyond reach of rivalry in this kind of writing" (Elwin and Courthope). For a full discussion of the date of composition, consult Pope's 'Works,' (Vol. III (Poetry), ed. Elwin and Courthope, 1881). Sir Leslie Stephen in his life of Pope in the 'English Men of Letters' series makes interesting comments on the satires.

MARION TUCKER.

**EPISTLE TO AUGUSTUS.** Pope's 'Epistle to Augustus' (1737) is a literary satire in imitation of the epistle which Horace addressed to the Emperor Augustus (Book II,

Ep. I). In his choice of topics and their order Pope follows his original rather closely, except of course that he substitutes English literature for Latin, London for Rome, and George II for Augustus. There is also a change of tone, in that Horace's eulogy of Augustus becomes bitterly ironical when applied to George II. Pope discusses the relative merits of ancient and modern English writers, the theatre, the London judgment of poets and poetry, the progress of poetic art and the poet's power to confer distinction upon his patrons. In effect, the whole is a satire upon George II, upon unworthy writers, and upon poor literary taste. Here and there occur passages full of sound sense and excellent literary criticism, expressed with Pope's characteristic terseness and point (for example, lines 213-20, on Dryden and Addison). The most celebrated passage in the 'Epistle' is perhaps the one on the progress of English poetic art (ll. 267-81), which states that

"Dryden taught to join  
The varying verse, the full-resounding line,  
The long, majestic march, and energy divine."

Though less frequently quoted than some others of Pope's poems, the 'Epistle' contains lines which have passed into the common use, such as "The last and greatest art—the art to blot."

MARION TUCKER.

**EPISTLE SIDE OF THE ALTAR**, the right side of the altar, looking toward it, so named because the epistle of the day is read at that side. It is secondary to the gospel or left side, and on fête days is occupied by the lesser ecclesiastical dignities.

**EPISTLES, Spurious.** See APOCRYPHA.

**EPISTLES OF HORACE.** See HORACE.

**EPISTOLÆ OBSCURORUM VIRO-  
RUM**, ē-pis'tō-lē ōb-skū-rō-rūm vi-rō-rūm (Lat. "Letters of obscure men"), a collection of satirical letters which appeared in Hagenau, Germany, in 1515-19, and professed to be the composition of certain ecclesiastics and professors in Cologne and other German towns. They were addressed to Ortunius Gatus at Deventer, who had gained the ill will of the liberals on account of his open hostility to them. They are considered one of the most masterly sarcasms in the history of literature, and their importance is enhanced by the effect they had in promoting the cause of the Reformation through their attacks upon scholastics and monks. The first issue consisted of 41 letters; but others were subsequently added. The authorship of this satire has been a fertile subject of controversy, but the major portion has been attributed to Reuchlin, Ulrich von Hutten and Erasmus, and also to Crotius Rubianus, the great humanist, who is said to have originated the idea of the letters and the title. The best edition is that of Böcking, supplementing his edition of the works of von Hutten (Leipzig 1864-70).

**EPISTOLER**, or **EPISTLER**, the clergyman in the English Church who assists the celebrant in administering Holy Communion, and who reads the epistle. The office corresponds to that of subdeacon in the Catholic Church.

**EPISTULÆ EX PONTO**, four books of letters, written by Ovid during his exile. They are made up for the most part of appeals to

his friends at Rome for intercession with the emperor. They are in elegiac metre.

**EPISTYLIUM**, or **EPISTYLE**, a beam of stone or wood, used to span the space between columns or pillars. It is synonymous with the term *architrave*.

**EPIGRAPH** (Gr. *ἐπιτάφιος*, *epitaphios*, funeral, from *ἐπι*, *epi*, upon, and *τάφος*, *taphos*, tomb), an inscription upon a tomb. The earliest known are those upon Egyptian sarcophagi. Epitaphs are common among many people, and arose, in all probability, out of the desire to commemorate the dead. They were in use among both the Greeks and Romans. Many of the later Greek epitaphs were of considerable length, while those of the Romans commonly recorded only brief particulars regarding the deceased. The tombs of the Romans were placed near the highways, and their epitaphs generally commenced with *Sta viator!* (Stop, traveler!). On Christian tombstones epitaphs frequently express the pious hopes of survivors in reference to the doctrines of the Christian faith. In the catacombs of Rome, which were made a place of refuge by the persecuted Christians under the pagan emperors, are many remarkable epitaphs of this description. Among memorable epitaphs, one of the happiest, is that of Sir Christopher Wren, in Saint Pauls, London, of which he was the architect:

*Si monumentum quaris circumspice  
"If you seek for his monument, look about you."*

The following is the epitaph of a Roman matron:

*Domum servavit,  
Lanam fecit.  
"She kept the house and span the wool."*

*Sta, viator: heroem calcas,—  
"Traveler, pause: thou treadest upon a hero,"*

has been ascribed both to Montecuculi and to Gen. Merci.

*Sufficit huic tumulus, cui non suffecerat orbis,—  
"This tomb suffices for him for whom the world did not suffice."*

was the epitaph of Alexander the Great.

Count Tessin, a governor under Gustavus III of Sweden, ordered the words

*Tandem felix,  
"Happy at last"*

to be inscribed on his tomb. The following is Sir Isaac Newton's epitaph:

*Isaacum Newton,  
Quem immortalem  
Testantur Tempus, Natura, Calum,  
Mortalem hoc Marmor,  
Fateatur.*

"This marble acknowledges Isaac Newton mortal, to whose immortality time, nature, and heaven bear witness."

Saint Anne's Church, at Cracow, has the following suggestive epitaph, dedicated by Count Sierakowski to Copernicus:

*Sta, sol, ne moveare.  
"Stand, O sun! move not."*

Many so-called epitaphs are merely epigrams, never intended for serious use as monumental inscriptions. Among such may be cited that of Piron, on Marshal de Belle-Isle, who was buried next to Turenne:

*Ci-est le glorieux a côté de la gloire.  
"Here beside glory lies the vainglorious."*

**Bibliography.**—Andrews, 'Curious Epitaphs' (London 1883); Armstrong, 'Autobi-

ographic Elements in Latin Inscriptions' (New York 1910); Blommaert, etc., 'Inscriptions funéraires et monumentales de la prov. de Flandre Orient' (Ghent 1857-60); Brown, J., 'Epitaphs' (Edinburgh 1867); Bücheler and Riese, 'Antologia Latina' (Vol. II, Leipzig 1869); Chwolson, 'Achtzehn hebräische Grabchriften aus der Krim' (1850); Hacket, 'Select and Remarkable Epitaphs' (1757); Kaibel, 'Epigrammata Græca ex Lapidibus Collecta' (Berlin 1878); Kippax, 'Churchyard Literature' (Chicago 1876); Labbe, 'Tesaurus Epitaphiorum' (Paris 1666); Le Blant, 'Inscriptions chrétiennes, etc.' (1856-65); Lewysohn, 'Sechzig Epitaphien von Grabsteinen' (1855); Loaring, 'Quaint, Elegant and Curious Epitaphs' (1872); Pettigrew, 'Chronicles of the Tombs' (1857); Preger, 'Inscriptiones Græcæ Metricæ ex Scriptoribus præter Antologiam Collectæ' (Leipzig 1891); Pulleyn, 'Churchyard Gleanings' (1830); Reinach, 'Traité d'épigraphie grecque' (Paris 1885); Robinson, 'Epitaphs from Cemeteries' (1859); Thompson, 'Tædium vitæ in Roman Sepulchral Inscriptions' (Saint Louis 1911); Tolman, 'A Study of the Sepulchral Inscriptions in Bücheler's Carmina Epigraphica Latina' (Chicago 1910); Weever, 'Ancient Funeral Monuments' (1631); Wordsworth, 'Essay on Epitaphs.'

**EPITHALAMIUM**, ἐπι-θᾶ-λά-μι-ῦμ (Lat. *epithalamion*, from the Gr. ἐπιθάλαμος, *epithalamios*, nuptial, from ἐπί, *epi*, upon, and θάλαμος, *thalamos*, a chamber), a nuptial song, a poem in honor of a newly married couple or one of the pair. Among the Greeks and Romans it was sung by young men and maids at the door of the bridal chamber of a newly-married couple. It consisted of praises of the bridegroom and bride, with wishes for their happiness. Examples may be seen in Theocritus' *epithalamium* of Helen, and the three *epithalamia* of Catullus, in which the Greek form is much modified. Some Roman *epithalamia* were collected by Wernsdorf in Vol. IV of his 'Poetæ Latinæ Minores' (Helmstedt 1789).

**EPITHELIOMA**, a species of cancer in which the disease attacks the surfaces covered with epithelium or epidermis. See **CANCER**.

**EPITHELIUM**, ἐπι-θῆ-λι-ῦμ, one of the simplest forms of tissue derived chiefly but not alone from the outer embryonic layers and characterized by its non-vascularity. It consists of flattened or columnar cells united into continuous membranes by an intercellular cement substance. Epithelium serves for the most part to protect exposed surfaces of the body, and performs the functions of absorption, secretion and excretion. The epithelial tissues are developed from all three layers of the developing embryo. They themselves secrete their own cement substance. This takes on the form of thin plates between the cells, gluing them together. Occasionally the epithelial cells develop short lateral projections (prickles), forming with similar structures of neighboring cells intercellular bridges, between which are intercellular spaces filled with lymph for the nourishment of the cells. Inasmuch as practically all epithelial cells have one exposed surface and one surface lying in contact with tissues underneath, the upper and lower surfaces show certain variations of structure.

Occasionally the free surface develops fine hairs or cilia. These are found in various localities. The outer surface of the cell, being exposed, develops more truly animal functions, the inner more vegetative. Blood vessels and lymph vessels do not penetrate, as a rule, into epithelial tissues, but they are richly supplied with nerve-end organs.

According to their shape and relation, the epithelial cells are divided into these varieties: (1) Simple epithelial cells, with or without cilia, comprising (a) squamous epithelium; (b) cubical epithelium; (c) columnar epithelium; (d) pseudostratified columnar epithelium. (2) Stratified epithelium, comprising (a) stratified columnar epithelium, with superficial flattened cells without cilia; (b) transitional epithelium; (c) stratified columnar epithelium. (3) Glandular epithelium. (4) Neuro-epithelium.

1. **Simple Epithelium**.—This is that type in which the cells lie in a single continuous layer. This form is found lining almost the entire alimentary tract, the smaller air-passages, the majority of the gland-ducts, the ovarian ducts, the uterus, the central canal, the spinal cord and the ventricles of the brain. In (a) simple squamous epithelium the cells are flattened, forming a mosaic with the nuclei lying in the middle of the cell. It is found in the alveoli of the lungs. In (b) simple cubical epithelium the appearance is that of short polygonal prisms. It occurs in the smaller bronchioles of the lung, in certain portions of the uriniferous tubules, the liver, pancreas, salivary and mucous glands. In (c) simple columnar epithelium the cells are pyramidal or prismatic. This type is found in the intestinal tract from the cardiac end of the stomach to the anus, and in certain portions of the kidney. Ciliated columnar is found in the ovarian duct and uterus, in the central canal of the spinal cord and in some of the smaller bronchi. (d).

2. **Stratified Epithelium**.—When the cells of simple epithelium increase to such an extent that layer upon layer is developed, the epithelium no longer remains simple, but becomes stratified. The lower layers are richly supplied with blood vessels, and multiply very rapidly, pushing out the upper layers that are constantly dying and being cast off. The various forms are: (a) Stratified columnar epithelium, with superficial flattened cells, forming the outer covering of the body, the epidermis and its continuations inside of the body, as, for instance, the walls of the œsophagus, the epithelium of the conjunctiva, the external auditory canal, the sheath of the hair-follicles, the walls of the rectum, the anus and the vagina. The deeper cells are usually cubic-cylindrical, and are followed, as a rule, by one or more layers of slightly flattened cells, until finally the outmost layers become very much flattened and horny, or they may be developed into distinct horn-like substances such as that found in the nails. (b) Transitional epithelium, a type of stratified epithelium found in the kidney, uterus, urethra and bladder. It is somewhat similar to the stratified columnar epithelium, but does not show the characteristic deep papillæ in the basal membrane, so characteristic of the former. (c) Stratified columnar epithelium, consisting of a superficial layer of columnar cells and deeper

layers of irregular, triangular, cubical or spindle-shaped cells. This type is found in the larger duct-glands, in the mucous membrane of the nose, portions of the male urethra and in parts of the larynx. Many of this type of cells have cilia, particularly those found in the back of the nose, larynx, respiratory tract, larger bronchi, Eustachian tube, epididymis and portions of the vas deferens.

**3. Glandular Epithelium.**—This is a type of epithelium occasionally found scattered among other epithelial cells, and which shows the characteristic of gland-structures. See GLANDS.

**4. Neuro-epithelium.**—Neuro-epithelial cells are highly specialized cells in which special nerve-end organs are to be found. In one sense nearly all epithelium is neuro-epithelium since many nervous receptors are located in flat, stratified epithelium and also both receptors and effectors are found in the epithelium of mucous membranes. Consult Bailey, 'Histology.'

**EPITHEM**, in botany, a gland which excretes water, or, the internal tissue of a hydrathode (q.v.).

**EPITOME**, ě-pit'ō-mē, a summary or abstract of any book or writing; a compendium containing the substance or principal matters of a book. Such digests or abstracts were common in the Middle Ages and have not been uncommon even in modern times, for instance, the abridgment of the French encyclopædia Larousse.

**EPIZOA**, in a general sense, external parasites, as contrasted with Entozoa, or internal parasites. These are not exact terms in scientific classification. Among them are the fleas, lice, ticks, itch-mites and similar minute "vermin" infesting man or beast.

In a more restricted sense the term is applied to the degraded, distorted copepod crustaceans parasitic upon the skin, gills and other parts of marine animals, especially fishes. See FISH-LICE.

**EPOCH**, or **ERA** (Gr. *ἐποχή*, *epoche*, epoch, pause). In history, a fixed point of time, commonly selected on account of some remarkable event by which it has been distinguished, and which is made the beginning or determining point of a particular year from which all other years, whether preceding or ensuing, are computed. Some writers distinguish between the terms epoch and era. According to them, both mark important events, but an era is an epoch which is chronologically dated from; an epoch is not marked in this way. The birth of Christ was thus both an epoch and an era from this point of view.

The more important historical epochs are here enumerated. For further details on the mode of reckoning see CALENDAR.

**The Creation.**—The biblical record of the creation has formed the foundation of numerous chronologies. Of course the authorities (Jewish and Christian) on these various modes of reckoning do not agree as to the time signified by the common authority for the event dated from. The more important of these epochs, of which there are about 140 different varieties, are (1) The epoch adopted by Bossuet, Ussher and other Catholic and Protestant divines, which places the creation in

4004 B.C. (2) The Era of Constantinople (adopted by Russia), 5508 B.C. The civil year begins 1 September, the ecclesiastical year about the end of March. (3) The Era of Antioch, used till 284 A.D., placed the creation 5502 B.C. It was merged in the following year in (4) The Era of Alexandria, which made the creation 5492 B.C. This is also the Abyssinian Era. (5) Jewish Era. The common era of the Jews places the creation in 3760 B.C. Their year is lunar-solar, that is, lunar with intercalary months, forming a cycle of 19 years, of which 12 have 12 months and seven 13 months. The year thus varies from 353 to 385 days. The civil year begins with the new moon following the autumn equinox. The eras dating from the creation are distinguished by the initials A. M. Const., Abyss., etc., are sometimes added to distinguish the particular epochs.

**Julian Period.**—This begins 4713 B.C. It is an arbitrary epoch, fixed for the purpose of computing all dates forward, as in the case of the creation epochs.

**The Olympiads.**—The Greeks computed their time by periods of four years, called Olympiads. Their year was lunar, with intercalary months. The first Olympiad, being the year in which Coræbus was victor in the Olympic games, was in the year 776 B.C. The period of the commencement of the year, which was variable, was about July. The contraction used for the Olympic epoch is Olymp.

**The Roman Era (Ab Urbe Condita).**—The Romans dated from the supposed era of the foundation of their city, 21 April, in the third year of the sixth Olympiad, or 753 B.C. (according to some authorities 752 B.C.). This epoch is designated by the initials A. U. C. The Roman mode of computation was the foundation of our modern chronology.

**Era of the Seleucides.**—Begins 1 Oct. 312 B.C., the epoch when Seleucus I (Nicator) took possession of Babylon. The year consisted of 365 days, with a leap year every fourth year. This era is used in the book of Maccabees.

**Spanish Era.**—This dates from 1 Jan. 38 B.C. The months and days were the same as those of the Julian calendar. It was disused in Aragon in 1350; in Valencia, 1358; in Castile, 1383; in Portugal, about 1415.

**Christian Era.**—Our mode of computing from supposed data of the birth of Christ was first introduced in the 6th century, and had not been generally adopted until the year 1000. Since the first year of the 1st century was 1 A.D., the last year of the same century was 100 A.D. Similarly the year 1900 A.D. was the last year of the 19th century. The same holds good in reckoning backward. For particulars of the mode of reckoning the years of the Christian era and the changes which it has undergone, see CALENDAR.

**Armenian Era.**—This began 7 July 552, and was superseded by the Julian era about 1330. The year consisted of only 365 days.

**Mohammedan Era, or Hegira.**—This begins on 16 July 622. The conversion of the Mohammedan into Christian chronology causes more difficulty and confusion than arises with any of the other modes of reckoning. The Mohammedan year is purely lunar. It consists of 12 months, and each month commences with the appearance of the new moon. Hence their

years have no correspondence with the recurrence of the seasons, and to know the period when a Mohammedan year begins it must be reckoned from the beginning of the era. In chronology, history, etc., they use months of 29 and 30 days alternately, making the year consist of 354 days. Eleven times in 30 years one day is added to the last month, making 355 days in the year. The mean length of the year is thus  $354 \frac{11}{30}$  days, of the month  $29 \frac{191}{360}$ , differing from the true lunation by little more than three seconds, or less than a day in 2,260 years. As 33 Mohammedan years amount to only six days (including intercalary days and leap years) more than 32 of our years, by deducting one year from each 33 Mohammedan years, and adding  $621\frac{1}{4}$  years, the year of the Christian era will approximately be found. The Hegira is distinguished by the initials A. H.

**Persian Era.**—The era of Yezdegird III began 16 July 632. The year consisted of 365 days. It was reformed in 1075 by the addition of a day whenever it was necessary to make the commencement of the year occur on the day of the sun's passing the same degree of the ecliptic. The months have each 30 days, with five or six days intercalated. This era is still used by the Parsees in India.

**Indian Chronology.**—The best-known eras computed by solar time are the Kaliyuga, which dates from 3,101 years before Christ and the Salivahana from 77 A.D. Both are computed astronomically, losing one day in 60 years by our computation. The era of Vikramaditya, beginning 57 years B.C., is computed by lunar months, with intercalations made according to astronomical observation, and bringing the year up to 365 or 366 days. The Bengali year was formerly identified with the Hegira, but is now reckoned by solar computation.

**Chinese Chronology.**—The Chinese, like all the nations of northeast Asia, reckon their time by cycles of 60 years. Instead of numbering them as we do, they give a different name to every year in the cycle. The Chinese months are lunar, of 29 and 30 days each. Their years have ordinarily 12 months, but a 13th is added whenever there are two new moons while the sun is in one of the zodiac. This will occur seven times in 19 years. The boasted knowledge of the Chinese in astronomy has not been sufficient to enable them to compute their time correctly. The first cycle, according to Roman Catholic missionaries, began February 2397 B.C. To find out the Chinese time multiply the elapsed cycle by 60 and add the odd years; then if the time be before Christ subtract the sum from 2,398; but if after Christ, subtract 2,397 from it; the remainder will be the year required.

**Primitive American Chronology.**—The natives of America, previous to its discovery by Europeans, particularly the Peruvians and Mexicans, appear to have had a considerable acquaintance with astronomy and to have reckoned their time with great care. The Mexican year consisted of 365 days, composed of 18 months of 20 days and five added days. At the end of a cycle of 52 years 12 and 13 days were added alternately, making the mean year very near the truth.

In geology, according to United States Geological Survey usage, a subdivision of a period of geologic time, the period in turn being a

subdivision of an era, the largest time unit in use. The rocks laid down during an epoch are usually known as a series, this term being used as a subdivision of a system, the latter being the rocks laid down during a period. The Cambrian (q.v.) period is usually divided into three epochs, Georgian, Acadian and Saratogan, and the Cambrian system into three corresponding series of rocks known by the same names. Other periods are also divided into epochs. The Eocene, Oligocene, Miocene and Pliocene are sometimes given the rank of periods, but are now generally considered to be epochs of the Tertiary period. While periods are divisions the nomenclature of which is fairly well standardized the world over, epochs are not so constant, and go by various names in various lands. See CAMBRIAN; ORDOVICIAN; EOCENE, etc.

In astronomy, epoch is the longitude which a planet has at any given moment of time. To predict this for any future period the longitude at a certain instant in the past must be known; that instant is termed the epoch of the planet.

**EPODE** (Lat. *epodus*, Gr. *epōdus*, an after song or epode). In Greek choral poetry the term is used of an ode succeeding a strophe and antistrophe, or a series of strophes and antistrophes. The name was also given by grammarians to any poem the material unit of which is a distich consisting of a long, followed by a short verse. In this sense it was especially used by the iambic trimeter followed by the iambic dimeter, as in Epodes 1–10 of Horace. In music the term epode is used to signify a burden or refrain.

**EPOMEIO**, ā-pō'mā-ō, a volcano, on the island of Ischia, Italy, 15 miles south by west of Naples. It has an elevation of 2,588 feet and commands a fine panoramic view of the coast with the famous bay of Naples. Terrific eruptions have marked its history; one in 474 B.C. caused most of the inhabitants to flee from the island. In 1302 occurred the last great upheaval. The mountain is sometimes known as Mount San Nicola, from the San Nicola Hermitage near the summit. The mount is mentioned in Virgil's 'Æneid,' IX, 716.

**EPONA**, the goddess of stables, asses, mules and horses. She was at first exclusively worshipped in Gaul but the cult spread to Rome in the 1st century of our era. Inscriptions to her have been uncovered in France, Germany, the Dobrudja and Italy. Consult Wissowa, 'Religion und Kultus der Römer' (2d ed., Munich 1912).

**EPONYM**, ěp'ō-nīm, a mythical personage created to account for the name of a tribe or people; thus Tros is the eponymous hero of Troy; Italus was assumed as ancestor of the Italians; Romulus of the Romans. It is also more generally used in the sense of names of people, places and periods derived from those of persons. Thus Bolivia is derived from Bolivar. Hearn, in his 'Aryan Household,' declares that "wherever there was a clan there was an eponym or founder, whether real or legendary, of that clan." By extension the term is also applied to the name of something, as a part or organ of the body derived from a person, as the fissure of Sylvius.

**EPONYMUS**, an adjective of Greek origin and meaning usually the giving of a name to



some person or thing. In ancient Greece it was especially applied to the ephor, from whom the year was named. Tribes and cities usually traced their origin to some eponymus ancestor, generally a national hero. Thus Tros is the eponymus hero of Troy, Italus of the Italians, etc.

**EPOREDIA.** See **IVREA**.

**EPOS.** See **NARRATIVE POETRY**.

**EPSES, John Wayles,** American statesman: b. Virginia 1773; d. near Richmond, Va., 20 Sept. 1823. He received an academic education, and after studying law was admitted to the bar and began practice in Richmond. In 1803 he was elected as a Democrat to the House of Representatives at Washington, and with successive re-elections served continuously from 17 Oct. 1803 to 3 March 1811. Later he was elected to the 13th Congress and served from 24 May 1813 to 3 March 1815. He was chosen United States Senator in 1817, but resigned the office two years afterward on account of failing health and retired to his estates in Chesterfield County. He married Maria, the daughter of Thomas Jefferson, who died at Monticello in April 1804.

**EPPING,** England, market town, in Essex, 17 miles from London and in the midst of the forest to which it gives name. This ancient royal forest, once a part of Waltham forest, and all much larger than at present, has an area of 6,000 acres and presents some fine woodland scenery. It was secured to the nation by legislative enactment and was opened by Queen Victoria in 1882 as a public recreation ground. The town consists of a single broad street on a ridge of hills. Pop. 4,253.

**EPPING FOREST.** See **EPPING**.

**EPSOM,** England, market town in the county of Surrey, 14 miles southwest of the heart of London. Epsom was formerly celebrated for a mineral spring, from the water of which the well-known Epsom salts were manufactured. A number of the sons of medical men are educated at the Royal Medical College, and adjoining the school is a home for aged physicians or their widows. The principal attraction Epsom can now boast of is the grand race-meeting held on the Downs, which is attended by hundreds of thousands of persons. The races begin on Tuesday and continue to the end of the week preceding Whitsuntide; the Derby stakes are run for on Wednesday, which is the principal day, and the Oaks on Friday. There is also racing on two days earlier in the season; the town being otherwise characterized as "a dull little place for 50 weeks in the year." Epsom gives name to one of the parliamentary divisions of the county. Pop. 19,156.

**EPSOM SALT,** a hydrous sulphate of magnesium, having the formula  $MgSO_4 + 7H_2O$ . It occurs abundantly in nature and takes its name from its occurrence, in dissolved form, in a mineral spring at Epsom, England. It may be prepared also from dolomite, by decomposing the mineral by the addition of sulphuric acid. Epsom salt, proper, is known to the mineralogist as epsomite, and more popularly as hair-salt, from the delicate fibrous efflorescent deposits in which it often occurs on the walls of mines, quarries and caves. Epsomite crystal-

lizes in the orthorhombic system, and large quantities of it are found in the limestone caves of Kentucky, Tennessee and Indiana, mingled with earthy matter. In the Mammoth Cave it occurs in loose masses suggestive of snowballs, adhering to the roof and walls. An allied mineral known as kieserite, which has the composition  $MgSO_4 + H_2O$ , and occurs abundantly at Stassfurt, is largely used as a source of epsom salt. Magnesium sulphate is used as a fertilizer, as a raw material for the manufacture of the sulphates of sodium and potassium and in sizing and dyeing cotton goods. The epsom salt is also extensively used as a purgative, in medicine.

**EPSOMITE,** natural magnesium sulphate of the same composition as Epsom salt ( $MgSO_4 + 7H_2O$ ). It has a bitter saline taste and is found in fibrous crusts in white botryoidal lumps.

**EPSTEIN, Jacob,** English sculptor: b. New York, 1880. He is of Polish-Prussian descent, made his studies under Rodin at Paris and settled in London. He was commissioned to execute 18 figures to decorate the new building of the British Medical Association in 1907-08. The work when finished was attacked by newspapers and various religious bodies, but was defended by the *Times*, Herbert Gladstone, Sir Martin Conway and others. Epstein was also commissioned to execute the tomb of Oscar Wilde in Père Lachaise Cemetery, Paris, which he completed in 1909. He also decorated Church Square, facing the government buildings, Pretoria, Transvaal. His art is intensely realistic and is a protest against the conventional imitation of the Greek.

**EPULIS.** See **MOUTH**.

**EPWORTH LEAGUE,** a society of young people of the Methodist Episcopal Church; formed 15 May 1889 in Cleveland, Ohio, by the union of five societies affiliated with the Methodist Church. It adopted as its motto: "Look up, Lift up," and its declared object is to "promote intelligent and loyal piety in the young members and friends of the Church; to aid them in the attainment of purity of heart and constant growth in grace, and to train them in works of mercy and help." The following pledge is required of its members: "I will earnestly seek for myself, and do what I can to help others to attain, the highest New Testament standard of experience and life. I will abstain from all forms of worldly amusement forbidden by the discipline of the Methodist Episcopal Church, and I will attend, as far as possible, the religious meetings of the chapter and the Church, and take some active part in them." The league exists in both the Northern and Southern branches of the Methodist Episcopal denomination and also in the Methodist Church of Canada. The league is governed by a board of control, partly appointed by the bishops and partly elected by the General Conference districts, one member for each district; represented by an executive cabinet, consisting of a president, four vice-presidents, general secretary, general treasurer and an assistant treasurer. The league has grown rapidly, extending to foreign lands, and there are chapters in India, Mexico, South America, Italy, Norway, Sweden, Denmark, Finland, China, Japan and Hawaii. There are in the league

about 30,000 chapters and over 2,000,000 members. Its official organ is the *Epworth Herald*, published in Chicago, which has a circulation of over 100,000. Consult Bacon and Northrop, 'Young People's Societies' (New York 1900); 'The Methodist Year Book'; Brummett, 'Epworth League Methods' (New York 1906).

**EQUAL RIGHTS PARTY**, in 1835. See **LOCOPHOS**.

**EQUAL RIGHTS PARTY**, in 1884. Belva Lockwood nominated herself for the presidency, on a platform of Woman Suffrage; and gave her voters this title.

**EQUALITY BEFORE THE LAW**, a fundamental of civil liberty, in which the equality of all men to receive the protection afforded by law is assumed. The guaranty of liberty and equal privilege to all freemen was embodied in Magna Charta (q.v.) in 1215, and in the Declaration of Independence the equality of all men with unalienable rights was emphasized. The equal protection of the laws excludes any distinction between individuals, invidious discrimination, and class legislation not founded on legal or reasonable distinctive grounds. See **DUE PROCESS OF LAW**; **COMMON LAW**.

**EQUATION**, a term based on the idea of equality, in general use throughout the various branches of calculus. (1) *In mathematics* it is the statement in algebraic expressions of the identity of two or other mathematical expressions. The assertion of equality is made by writing the sign  $=$  (read "is equal to" or "equals") between the expressions. Thus:  $5x + 7 = 32$ , and  $ax^2 + bx + c = 0$ , are equations, each of which indicates the equality of the quantity written on the left of the sign ( $=$ ) to that written on the right of the sign. Usually the object of writing down an algebraic equation is to express in symbols known relations between given and unknown quantities, so that by algebraic processes the latter may be determined in terms of the former. Such equations are designated *conditional*, while equations which are true for all values of the variables they involve or which involve no variables, are called *identities*. (See **ALGEBRA**, **DEFINITIONS AND FUNDAMENTAL CONCEPTS**). (2) *In astronomy*, is the correction by addition to or subtraction from the mean motion of any heavenly body in order to determine its true place at any given time. The angular motion of a planet around the sun will not be uniform if its orbit is not circular, regardless of any perturbations. Furthermore, the mutual attraction among the planets renders each one capable of producing a perturbation in the orbits of all the others. An equation is required for every such perturbation before it is possible to calculate accurately the course of the planet. Thus

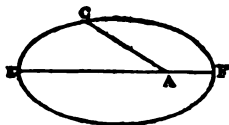

we have the equation of the centre, a quantity to be added to or subtracted from the anomaly, in order to determine the true position of a heavenly body. For instance, let the curve  $E C F$  represent the earth's orbit (which is an

ellipse),  $E F$  the line of the apses, and  $A$  the position of the sun. When the earth is in any position as  $C$ , the line  $A C$  drawn from the sun to the planet is the radius vector, then will the angle  $C A F$  be the anomaly, or the angular distance from the perihelion. Were the earth's angular motion uniform the increase or decrease of this angle would be equal in equal times, and the mean anomaly would be the true anomaly; but the earth's motion is retarded as it advances from  $F$  to  $C$ , is slowest at  $E$ , and is accelerated from that point, the aphelion, through the other half of its orbit till it arrives at  $F$ , the perihelion. The quantity to be added to the mean angular motion, during one portion of the orbit, or subtracted from it in the other, in order to find that true anomaly, is called the equation of the centre. (3) *In chemistry*, is a collection of symbols to denote that two or more definite bodies—simple or compound—have been brought within the sphere of chemical action, that a reaction has taken place, and that new bodies are produced. It is called an equation because the total weight of the substances concerned remains the same. Equations may also involve the energy consumed or given off in a reaction. See **CHEMISTRY**.

**EQUATION, Personal**, an important correction that must be considered in connection with refined measurements in astronomy and physics, and which originates in the fact that no two observers agree precisely as to the instant at which a phenomenon occurs, nor as to the setting of a micrometer-wire so as to bisect a division mark on a scale. Differences of this sort are exceedingly irregular among inexperienced observers, but among the more experienced ones the regularity, while not absolute, is strongly marked. In some kinds of work the personal equation of the observer can be eliminated by the method in which the observations are made. Thus in the determination of differences of longitude by telegraphic methods, it is usual to eliminate the effect of personal error from the final result by having the observers change places when the work is half done; so that if the difference of longitude as determined by the first half of the work was too large, that determined during the second half will be too small by an equal amount, and the effect of personal equation will disappear from the final mean. In other cases it is impossible to eliminate the effects of personal error in any such way, and in these cases the attempt is often made to determine the magnitude of the personal equation, and apply the proper correction to the results as directly observed. Thus Otto Struve, in connection with his measurements on double stars, had artificial double stars constructed, upon which he made regular observations for the purpose of studying his personal equation in such work, and he applied to his results for the genuine stars, a series of corrections deduced in this way. When the thing to be measured is an interval of some kind, the personal equation can usually be neglected, provided the same observer makes all the measures. For example, in determining the length of a bar, the reading of the micrometers will be in error (so far as the personal equation is concerned) by the same amount at both ends of the bar, and hence the

difference of these readings; or, in other words, the observed length of the bar will be independent of the observer's personal equation.

**EQUATIONS, Differential. 1. Introduction.**—The invention of the calculus, made necessary by the demands of natural science, was followed immediately by the most brilliant applications. The names of Newton, Leibnitz, Euler, Lagrange and Laplace are attached to the principal discoveries of this period, whose importance from a scientific and philosophical point of view can hardly be overestimated. A simple example will suffice to explain the ruling idea of this epoch. From the observations of Tycho Brahe, Kepler had obtained the laws of planetary motion still known by his name. Newton had shown that Kepler's laws were but a consequence of the laws of universal gravitation, which assumes that every particle in the universe acts upon every other according to a definite law. The effect of Newton's law upon a system of moving bodies can be formulated in mathematical symbols without any difficulty. This formulation gives rise to a system of equations involving the co-ordinates of the moving bodies and their accelerations, i.e., the second derivatives of these co-ordinates with respect to the time. The problem of expressing the co-ordinates as functions of the time, i.e., the problem of integrating this system of differential equations, was solved by Newton for the case of two mutually attracting bodies, and its solution is given precisely by Kepler's laws. Newton himself and his successors, especially Laplace and Lagrange, studied the further consequences of the law of gravitation as applied to the solar system. The accord between the theory and observation became closer and closer, so that it was reasonable to suppose that the true law of nature had been found. Gradually other branches of physical science were treated in a similar way. In all cases, the fundamental laws being assumed, the mathematical formulation of the problems led to the question of integrating differential equations. It should be noted that, although in some cases this method of arriving at the formulation of the physical problems has now been abandoned, differential equations are now, more than ever, used as the expressions for the fundamental phenomena in physical science. For the applications of mathematics there is no field so important as the theory of differential equations. That the whole world is a mathematical problem was the point of view gained by Laplace, an insight gained in a different way also by Leibnitz and Spinoza. But the mathematician is more specific; we learn from him that this world-problem belongs to the domain of the theory of differential equations. Even if the details of the picture have changed, the formulation of this general idea is one of the positive achievements of the philosophical thought of the 18th century.

**Ordinary Differential Equations; Elementary Theory.**—Let  $y$  be determined as a function of  $x$  by means of an equation,

$$(1) \quad \phi(x, y, a) = 0,$$

which involves an arbitrary constant  $a$ . If  $x$  and  $y$  be interpreted as the co-ordinates of a point in the plane, equation (1) represents a family of curves, one curve for each value of  $a$ .

By differentiation we find, from (1),

$$(2) \quad \frac{\partial \phi}{\partial x} + \frac{\partial \phi}{\partial y} \frac{dy}{dx} = 0.$$

Between these two equations  $a$  may be eliminated; the result will be an equation of the form

$$(3) \quad f\left(x, y, \frac{dy}{dx}\right) = 0,$$

free from  $a$ . Equation (3) is a *differential equation*. Since it does not contain the constant  $a$  it gives the expression of a property which is common to all of the curves of the family (1). The main object of the theory of differential equations is to invert the process which we have just carried out, i.e., the equation (3) being given, the equation (1) involving an arbitrary constant, from which (3) may be derived by differentiation, is to be found. This process is known as the *integration of the differential equation*.

In general let there be given an equation of the form

$$f\left(x, y, \frac{dy}{dx}, \frac{d^2y}{dx^2}, \dots, \frac{d^ny}{dx^n}\right) = 0,$$

between  $x$ , the function  $y$  of  $x$  and its derivatives up to the  $n$ th order; it is called an *ordinary differential equation of the  $n$ th order*. The adjective *ordinary* implies that  $y$  is considered as a function of only *one* independent variable  $x$ . Under certain restrictions as to the continuity of the function  $f$  (a question to which we shall recur later), it may be shown that there exists a function  $y$  of  $x$  and of  $n$  arbitrary constants which satisfies the differential equation; it is known as the *general integral of the differential equation*; the determination of this function is the object of the theory of differential equations. The equation is then said to have been *integrated*.

The simplest case of such a differential equation presented itself in the problem of finding the area included between a curve  $y=f(x)$ , the  $x$ -axis, and two ordinates erected for  $x=a$  and  $x=x$ . The differential equation satisfied by the area  $s$  considered as function of  $x$  is

$$\frac{ds}{dx} = f(x),$$

and the area itself becomes

$$s = \int_a^x f(x) dx.$$

This simple case served as a model for the earlier investigators in this field. Confining ourselves for the moment to equations of the first order, it may be possible to reduce such an equation to the form

$$\frac{dx}{R(x)} + \frac{dy}{S(y)} = 0,$$

where  $R(x)$  is a function of  $x$ , and  $S(y)$  a function of  $y$  alone. The variables are then said to be *separated*, and we may write

$$\int \frac{dx}{R(x)} + \int \frac{dy}{S(y)} = c,$$

where  $c$  is an arbitrary constant. Owing to the fact, which has just been mentioned, that the problem of areas is solved by the com-

putation of an integral of the form  $\int_a^x f(x) dx$ ,

such an integration is known as a *quadrature*. If the variables can be separated, the differential equation may, therefore, be integrated by quadratures.

The earlier analysts believed that any differential equation could be integrated by the elementary functions then in use, and by quadratures. This we now know not to be the case, just as we know, since the days of Abel, that all algebraic equations cannot be solved by the mere extraction of roots. (See ALGEBRA; THEORY OF EQUATIONS; GALOIS' THEORY). Moreover, even if the reduction to quadratures can be effected, such a reduction is, properly speaking, the beginning and not the end of the investigation. For it does not suffice to give a formal indication of the relation between  $x$  and  $y$ ; this relation must be thoroughly understood in its essential properties before the integration can be said to have been accomplished. Nevertheless the consideration of the simpler cases, in which integration by means of elementary functions or by quadratures is possible, constitutes a first important chapter of the theory of differential equations. We may characterize this chapter as the *elementary theory of differential equations*.

**Elementary Theory of Differential Equations.**—We have already referred to the case in which the variables are separated. In many cases a simple transformation will accomplish the separation. Consider, for example, the equation

$$(4) \quad \frac{dy}{dx} + Py = 0,$$

where  $P$  is a function of  $x$  only. We may write

$$\frac{dy}{y} + Pdx = 0,$$

whence

$$\log y + \int Pdx = \log c,$$

or

$$(5) \quad y = ce^{-\int Pdx}.$$

This example will be useful in enabling us to treat, at once, a more general equation; we shall do so, moreover, by making use of a method frequently employed, and especially important in the applications to theoretical astronomy, the method of *variation of constants*. We consider the equation

$$(6) \quad \frac{dy}{dx} + Py = Q,$$

where  $P$  and  $Q$  are functions of  $x$  only. This equation is the most general linear differential equation of the first order, a linear equation being one which contains  $y$  and its derivatives in no higher than the first power. Equation (6) differs from (4) only in having  $Q$  in the right member in place of zero. The expression (5) will certainly not satisfy (6) since it satisfies (4). Clearly, however, it must be possible to satisfy (6) by an expression of the form analogous to (5), viz.,

$$(7) \quad y = ue^{-\int Pdx},$$

where  $u$  is a properly chosen function of  $x$  instead of being a constant. Moreover, as we shall see, we can actually determine the function  $u$  by quadratures. In fact, we find from (7)

$$\frac{dy}{dx} = \left( \frac{du}{dx} - Pu \right) e^{-\int Pdx},$$

which gives, on substitution into (6)

$$\frac{du}{dx} = Qe^{\int Pdx}$$

so that we shall have

$$(8) \quad y = e^{-\int Pdx} \left[ C + \int Qe^{\int Pdx} dx \right],$$

as the general integral of (6). This formula was found by Jacob Bernoulli, who also showed that the equation

$$(9) \quad \frac{dy}{dx} + Py = Qy^{-m+1}$$

could be reduced to (6) by putting  $u = y^m$ .

The *homogeneous* equations of the form

$$(10) \quad \frac{dy}{dx} = \phi \left( \frac{y}{x} \right),$$

where  $\phi \left( \frac{y}{x} \right)$  depends only upon the ratio of  $y$  to  $x$ , may be solved by quadratures. In fact, if we put  $y = vx$ , the equation becomes

$$\frac{dx}{x} + \frac{dv}{v - \phi(v)} = 0,$$

whence

$$(11) \quad \log x + \int \frac{dv}{v - \phi(v)} = c.$$

Euler's method of the *integrating factor* is sometimes useful. It rests upon the following considerations. Let  $\phi(x, y) = \text{const.}$  be the equation of any integral curve of the equation

$$(12) \quad P(x, y)dx + Q(x, y)dy = 0.$$

We shall have, by differentiation from  $\phi(x, y) = \text{const.}$ ,

$$\frac{\partial \phi}{\partial x} dx + \frac{\partial \phi}{\partial y} dy = 0,$$

an equation which must have the same significance as (12). We must, therefore, have

$$(13) \quad \mu P(x, y) = \frac{\partial \phi}{\partial x}, \quad \mu Q(x, y) = \frac{\partial \phi}{\partial y},$$

if  $\mu$  is a properly chosen function of  $x$  and  $y$ . If  $\mu$  is known, the determination of  $\phi$  by quadratures can be immediately accomplished on account of the two equations (13). For this reason  $\mu$  is called an *integrating factor*. Equations (13) show that  $\mu$  must satisfy the partial differential equation

$$(14) \quad \frac{\partial(\mu P)}{\partial y} - \frac{\partial(\mu Q)}{\partial x} = 0.$$

In general, the determination of an integrating factor is just as difficult as the integration of the equation. But Euler succeeded in finding a number of equations with known integrating factors. Herein lies the value of the method.

By means of these various methods there was obtained in the course of time a considerable number of equations which could be integrated by quadratures. Lie showed that this rather scrappy theory could be understood as the consequence of a single principle. This we shall now proceed to explain, making use of geometric images for the sake of clearness as well as brevity.

The equations

$$x_1 = \phi(x, y), \quad y_1 = \psi(x, y),$$

are said to constitute a *transformation* of the point  $(x, y)$  into the point  $(x_1, y_1)$  if they can be solved for  $x_1$  and  $y_1$ .

These equations may contain a certain number of arbitrary constants  $a_1, \dots, a_r$ ; they are then said to constitute an  $r$ -parameter family of transformations. Let us consider the simplest case of a one-parameter family which we may write

$$(15) \quad x_1 = \phi(x, y; a), \quad y_1 = \psi(x, y; a).$$

If the parameter  $a$  has a definite value, this transformation converts every point  $(x, y)$  into a definite other point  $(x_1, y_1)$ . Let us transform this new point  $(x_1, y_1)$  by equations of the same form, but with a different parameter  $b$ , into a third point  $(x_2, y_2)$ , so that we shall have

$$(16) \quad x_2 = \phi(x_1, y_1; b), \quad y_2 = \psi(x_1, y_1; b).$$

In general, if we eliminate  $x_1, y_1$  between (15) and (16) we shall find  $x_2$  and  $y_2$  as functions of  $x, y, a$  and  $b$ . It may happen that these functions assume the form

$$(17) \quad x_2 = \phi(x, y; c), \quad y_2 = \psi(x, y; c)$$

where  $c$  is a function of  $a$  and  $b$ , and where the functions  $\phi$  and  $\psi$  are the same as in (15) and (16). If this is the case, the transformations (15) are said to form a one-parameter group. The one-parameter family of transformations (15) then has the property that the transformation, obtained by combining any two of its transformations, is itself a member of the family. It is for this reason that the family is then called a group. (See GROUPS, THEORY OF). It is obvious how this definition may be extended to cover  $r$ -parameter groups.

The one-parameter group (15) will contain, in general, the identical transformation; i.e., for a certain value  $a_0$  of  $a$  (15) will reduce to  $x_1 = x, y_1 = y$ . If now we denote by  $dt$  an infinitesimal, and put in (15)  $a = a_0 + cdt$ , we shall find a transformation which transforms  $(x, y)$  into a point  $(x_1, y_1)$  such that the differences  $x_1 - x = \delta x$  and  $y_1 - y = \delta y$  will be infinitesimals of the order of  $dt$ . This will be true unless certain exceptional cases arise which we need not, at present, discuss. From every one-parameter group we may deduce in this way an infinitesimal transformation, and Lie has shown that conversely every infinitesimal transformation determines a one-parameter group. There is a similar connection between an  $r$ -parameter group and a corresponding set of  $r$  infinitesimal transformations, between which certain relations must then be satisfied.

A one-parameter group always has an invariant: i.e., there exists a function  $\Omega(x, y)$  such that, for all transformations (15) of the group,  $\Omega(x_1, y_1) = \Omega(x, y)$ . Such a function is said to admit the one-parameter group of transformations. It admits, in particular, the infinitesimal transformation of the group. Similarly, a differential equation may admit one or more infinitesimal transformations. Lie has shown that in the cases in which the variables may be separated, i.e., in which integration by quadratures is possible, it is possible to write down infinitesimal transformations which leave the equations invariant. He has developed a general theory showing what advantage is gained for the integration of a differential equation by the knowledge that it admits one or more infinitesimal transformations. Let us remark, explicitly, that this theory is not confined to equations of the first order nor even to ordinary differential equations.

Before passing to the consideration of the ele-

mentary theory of equations of higher order, we proceed to explain the important notion of singular solution. Geometrically, an equation of

the first order  $\frac{dy}{dx} = \phi(x, y)$  determines the tan-

gent of an integral curve at every point of the plane. If we start from any point  $P$ , the tangent of the integral curve passing through that point is completely determined. We follow the direction thus indicated for an infinitesimal distance to the point  $(x + \delta x, y + \delta y)$ . At this point the tangent is again given by the differential equation, etc. We obtain in this way, synthetically, the family of integral curves, say  $F(x, y, c) = 0$ . Any one of these curves is obtained by giving a definite value to the constant of integration  $c$ . The envelope of this system of curves, however, will also be a solution of the differential equation. For it will also be a curve whose tangent satisfies the requirements of the equation. But, in general, the envelope will not be itself a member of the family of curves, i.e., it will not be possible to find its equation by giving a special value to  $c$ . The envelope is then said to give a singular solution of the equation. If it exists, it may be found without any integration, that is to say, without a knowledge of the general integral of the differential equation.

The most important case of a differential equation of a higher order, which may be treated by elementary methods, is that of the linear homogeneous differential equation of the  $n$ th order with constant coefficients. A linear homogeneous differential equation of the  $n$ th order has the form

$$(18) \quad \frac{d^ny}{dx^n} + p_1 \frac{d^{n-1}y}{dx^{n-1}} + \dots + p_n y = 0.$$

If  $y_1, y_2, \dots, y_n$  are particular solutions of the equation,  $y = c_1 y_1 + c_2 y_2 + \dots + c_n y_n$ , where  $c_1, \dots, c_n$  are constants, is also a solution. Moreover, if  $y_1, \dots, y_n$  are linearly independent, i.e., if they satisfy no relation of the form  $\gamma_1 y_1 + \gamma_2 y_2 + \dots + \gamma_n y_n = 0$ , where  $\gamma_1, \dots, \gamma_n$  are constants, the above expression for  $y$  is the general solution.  $y_1, \dots, y_n$  are then said to constitute a fundamental system of solutions. In the case that  $p_1, \dots, p_n$  are constants a fundamental system may be easily obtained. In fact we find that  $y = e^{\rho x}$  is a solution of (18) if  $\rho$  is a root of the equation

$$\rho^n + p_1 \rho^{n-1} + \dots + p_{n-1} \rho + p_n = 0.$$

Moreover, if  $\rho_1, \dots, \rho_n$  are the roots, supposed distinct, of this equation,  $e^{\rho_1 x}, e^{\rho_2 x}, \dots, e^{\rho_n x}$  actually form a fundamental system. If  $\lambda$  roots, say  $\rho_1, \rho_2, \dots, \rho_\lambda$ , coincide, the  $\lambda$  identical functions  $e^{\rho_1 x}, \dots, e^{\rho_\lambda x}$  are replaced by  $e^{\rho_1 x}, x e^{\rho_1 x}, x^2 e^{\rho_1 x}, \dots, x^{\lambda-1} e^{\rho_1 x}$ .

**Total Differential Equations.**—In the case of an equation between two variables which we have considered so far, one important distinction, which we shall now have to make, has not been necessary. If  $P(x, y)dx + Q(x, y)dy = 0$  is such an equation, it is always possible to find a single function  $\phi(x, y)$  such that  $\phi(x, y) = \text{const.}$  shall represent the general integral. Either the expression  $Pdx + Qdy$  is the complete differential of  $\phi(x, y)$  so that  $P = \frac{\partial \phi}{\partial x}$  and  $Q = \frac{\partial \phi}{\partial y}$ , or else upon multiplication with Euler's in-

tegrating factor  $\mu(Pdx + Qdy)$  becomes such a complete differential. This is not the case when there are more than two variables. Consider such an equation in three variables,

$$(19) \quad Pdx + Qdy + Rdz = 0,$$

where  $P, Q, R$  are functions of  $x, y,$  and  $z$ . For the sake of symmetry assume that  $x, y, z$  are regarded as functions of a fourth variable  $t$ . The problem before us is to find all sets of functions  $x, y, z$  of  $t$  which will satisfy (19). It may happen that the left member of (19) becomes a complete differential upon multiplication with a function  $\mu$  of  $x, y, z$ , so that

$$\mu P = \frac{\partial\phi}{\partial x}, \quad \mu Q = \frac{\partial\phi}{\partial y}, \quad \mu R = \frac{\partial\phi}{\partial z}.$$

The elimination of  $\mu$  from these three equations shows that this can be the case only if  $P, Q, R$  satisfy the so-called integrability condition:

$$(20) \quad P \left( \frac{\partial Q}{\partial z} - \frac{\partial R}{\partial y} \right) + Q \left( \frac{\partial R}{\partial x} - \frac{\partial P}{\partial z} \right) + R \left( \frac{\partial P}{\partial y} - \frac{\partial Q}{\partial x} \right) = 0.$$

Moreover it may be shown that if  $P, Q, R$  satisfy this condition, there exists a function  $\phi(x, y, z)$  and an integrating factor  $\mu(x, y, z)$  such that

$$\mu(Pdx + Qdy + Rdz) = d\phi,$$

so that integration of (19) will give the result  $\phi(x, y, z) = \text{const.}$  But if (20) is not satisfied, no integration of (19) in this sense is possible. The reason for this distinction as well as the discussion of the non-integrable case will be clearly understood if we make use of a geometric interpretation. Let  $x, y, z$  be Cartesian co-ordinates of a point in space. If  $x, y, z$  are known as functions of  $t$ , there will be determined a certain space-curve. It is our problem to determine such space-curves

$$x = f(t), \quad y = g(t), \quad z = h(t)$$

as satisfy (19). Through every point  $(x_0, y_0, z_0)$  of space there may be drawn an infinity of such curves. The tangents of all of these curves which pass through the point  $(x_0, y_0, z_0)$  form a plane pencil with  $(x_0, y_0, z_0)$  as vertex and the plane

$$P(x_0, y_0, z_0)(x - x_0) + Q(x_0, y_0, z_0)(y - y_0) + R(x_0, y_0, z_0)(z - z_0) = 0$$

as plane. Thus there is for every point  $P$  a plane  $p$  containing  $P$ , to which all of the integral curves of (19) which pass through  $P$  must be tangent. We may now imagine an integral curve of (19) constructed as follows: Start from a given point  $P$  and construct the corresponding plane  $p$ . We go from  $P$  to a point  $Q$  infinitesimally close to  $P$  but otherwise arbitrarily situated in the plane  $p$ . At  $Q$  we construct the plane  $q$  corresponding to it, and in this plane we pick out a point  $R$  infinitesimally close to  $Q$ . Proceeding in this way we gradually build up an integral curve. It may happen that all of the integral curves of (19) which pass through the point  $P$  are situated upon a certain surface  $S$ . If this is the case for all points  $P$ , the integrability condition is satisfied; there exists a single infinity of surfaces  $\phi(x, y, z) = c$ , such that an arbitrary curve upon each of these surfaces satisfies the differential equation. In general, however, such a family of surfaces does not exist. We may then integrate (19) as follows: Take an arbitrary surface  $\phi(x, y, z) = 0$ . Let  $P$  be any point

upon it. Let  $p$  be the plane of the pencil of directions which the differential equation assigns to  $P$ , and let  $p'$  be the plane tangent to the surface  $\phi(x, y, z) = 0$  at  $P$ . The intersection  $t$  of  $p$  and  $p'$  will be at the same time tangent to an integral curve of (19) and tangent to the surface  $\psi = 0$ . From  $P$  we go along  $t$  to a point  $Q$  infinitesimally close to  $P$  and there repeat this process. We may build up in this way all of the integral curves of (19) which are situated upon an arbitrary surface. Upon every arbitrary surface there will be a single infinity of such curves. Analytically this process may be carried out as follows: From  $\psi = 0$  we find

$$\frac{\partial\psi}{\partial x} dx + \frac{\partial\psi}{\partial y} dy + \frac{\partial\psi}{\partial z} dz = 0.$$

From this equation and  $\psi = 0$ ,  $dz$  and  $z$  may be expressed in terms of  $x, y, dx$  and  $y$ . Substitution of these values into (19) gives rise to an equation of the form

$$M(x, y) dx + N(x, y) dy = 0,$$

which may be integrated, in the form  $\phi(x, y) = c$ . This latter equation together with  $\psi(x, y, z) = 0$  gives the required solution. By giving all possible forms to the functions  $\psi$  all possible solutions will be obtained.

Similar considerations are necessary in the general case of  $n$  variables. The first considerable contribution to this theory is due to Pfaff. For this reason such an equation is known as a *Pfaffian equation*, and the problem of its integration as *Pfaff's problem*. The problem leads to a system of no more than  $n$  integral equations when the number of variables is  $2n$  or  $2n - 1$ . If the equations are of higher than the first degree in the differentials, Lie speaks of them as *Monge equations*. Many problems of differential geometry, especially in relation to the theory of complexes, are connected with Pfaffian and Monge equations.

**Partial Differential Equations.**—Frequently functions of several variables are defined by relations between those functions and their partial derivatives. Such equations are called partial differential equations. For the sake of simplicity we will confine ourselves to the case of a single unknown function, and for the most part to the case of two independent variables. As in the case of ordinary differential equations, it will be instructive to see first how such equations may arise as the result of elimination of arbitrary elements from equations which do not involve the derivatives. Let  $z$  be given as a function of  $x, y$  and of the two arbitrary constants  $a, b$  by the equation

$$(21) \quad f(x, y, z; a, b) = 0.$$

Let  $p, q$  represent  $\frac{\partial z}{\partial x}$  and  $\frac{\partial z}{\partial y}$  respectively,

Then differentiation will give

$$(22) \quad \frac{\partial f}{\partial z} p + \frac{\partial f}{\partial x} = 0, \quad \frac{\partial f}{\partial z} q + \frac{\partial f}{\partial y} = 0.$$

Between the three equations (21) and (22)  $a$  and  $b$  may be eliminated. Let

$$(23) \quad F(p, q; x, y, z) = 0.$$

be the result of this elimination. It is the partial differential equation which corresponds to (21); (21) is called the *complete integral* of (23).

But  $a$  and  $b$  in (21) may be functions of  $x, y$  and still the result of the elimination may

be the same equation (23). In fact we find from (21), assuming that  $a$  and  $b$  are functions of  $x$  and  $y$ .

$$\frac{\partial f}{\partial x} p + \frac{\partial f}{\partial x} + \frac{\partial f}{\partial a} \frac{\partial a}{\partial x} + \frac{\partial f}{\partial b} \frac{\partial b}{\partial x} = 0,$$

$$\frac{\partial f}{\partial x} q + \frac{\partial f}{\partial y} + \frac{\partial f}{\partial a} \frac{\partial a}{\partial y} + \frac{\partial f}{\partial b} \frac{\partial b}{\partial y} = 0,$$

which equations will reduce to (22), and therefore give rise to the same equation (23), if

$$(24) \quad \frac{\partial f}{\partial a} \frac{\partial a}{\partial x} + \frac{\partial f}{\partial b} \frac{\partial b}{\partial x} = 0, \quad \frac{\partial f}{\partial a} \frac{\partial a}{\partial y} + \frac{\partial f}{\partial b} \frac{\partial b}{\partial y} = 0.$$

Let the determinant of these equations be denoted by  $\Delta$ , so that

$$\frac{\partial a}{\partial x} \frac{\partial b}{\partial y} - \frac{\partial a}{\partial y} \frac{\partial b}{\partial x} = \Delta;$$

then we may write, in place of (24), the equivalent equations

$$(24a) \quad \Delta \frac{\partial f}{\partial a} = 0, \quad \Delta \frac{\partial f}{\partial b} = 0.$$

If  $\Delta \neq 0$ , we must therefore have

$$\frac{\partial f}{\partial a} = 0, \quad \frac{\partial f}{\partial b} = 0.$$

From these equations  $a$  and  $b$  may be obtained as functions of  $x$  and  $y$ ; if these values are substituted in (21), a function  $z$  of  $x$  and  $y$  is obtained, independent of any arbitrary constants, but still a solution of the partial differential equation (23). This solution is called a *singular* integral of (23). It may or may not be a special case of the complete integral.

Equations (24a) are also satisfied if  $\sqrt{\Delta} = 0$ , i.e., if

$$(25) \quad b = \phi(a),$$

where  $\phi(a)$  denotes an arbitrary function of  $a$ . If we multiply the left members of (24) by  $dx$  and  $dy$  respectively, and add, we find

$$\frac{\partial f}{\partial a} da + \frac{\partial f}{\partial b} db = 0,$$

whence, since  $db = \phi'(a) da$ ,

$$(26) \quad \frac{\partial f}{\partial a} + \frac{\partial f}{\partial b} \phi'(a) = 0.$$

If we eliminate  $a$  and  $b$  from the equations (21), (25) and (26), we find  $z$  as a function of  $x$  and  $y$ , the expression of which depends upon the arbitrary function  $\phi$ . Moreover this function  $z$  will again be a solution of (23). It is known as the *general integral* and involves an arbitrary function. It may be shown that every integral of such a partial differential equation belongs to one of these three classes.

Geometrical interpretation will again render the matter perfectly clear. Let  $x, y, z$  be coordinates of a point in space; (21) will represent a two-parameter family of surfaces, or, as we may say, a family of  $\infty^2$  surfaces. The equation of the plane tangent to one of these surfaces at a point  $(x, y, z)$  will be

$$\xi - z = p(\xi - x) + q(\eta - y).$$

For a fixed value of  $x, y, z$ , (23) gives therefore an infinity of planes through that point (enveloping a cone); any integral surface of (21), which passes through that point must have one of these planes as its tangent plane. In other words, the differential equation determines a certain cone corresponding to every point of space, and with this point as vertex;

an integral surface must be tangent at each of its points to the corresponding cone. Now let a complete solution of the equation be given, so that we know a family of  $\infty^2$  surfaces each of which fulfils the requirements of the problem. If we put  $b = \phi(a)$ , where  $\phi(a)$  is any function of  $a$ , we obtain a one-parameter family of surfaces included among the  $\infty^2$  surfaces just mentioned. The envelope of this one-parameter family is given by the general integral. The singular integral is the envelope of all of the  $\infty^2$  surfaces of the complete integrals, provided that such an envelope exists.

Since the surface represented by the general integral is the envelope of a single infinity of surfaces represented by the complete integral, each of these latter surfaces will touch the former along a certain curve; such a curve is known as a *characteristic*. If the partial differential equation is not linear in  $\frac{\partial z}{\partial x}$  and  $\frac{\partial z}{\partial y}$

there are  $\infty^2$  characteristics. A linear equation has only  $\infty^1$  characteristics. The integral surfaces may be looked upon as generated by characteristics, and the usual method of integrating the partial differential equation consists in setting up a system of ordinary differential equations which determines the characteristics.

**The points of view in the higher theory.**—In speaking of ordinary differential equations, we have already mentioned the fact that the point of view of the elementary theory is inadequate even in those cases in which the reduction to quadratures is possible. Given for example, the equation

$$\left(\frac{dy}{dx}\right)^2 = (1 - y^2)(1 - k^2 y^2),$$

which may be reduced to a quadrature,

$$x = \int \frac{dy}{\sqrt{(1 - y^2)(1 - k^2 y^2)}}.$$

The reduction of the equation to this form is a mere formal process which, in itself, teaches us nothing. We shall have to ask ourselves the following questions: to what extent does a given differential equation define a function  $y$  of  $x$ ? what are the characteristic properties of this function? what analytical processes involving known functions, infinite series, products, etc., will serve for the computation of the values of the function for all of the values of its argument? In the case of the above differential equations these questions have been completely answered by the creation of the theory of elliptic functions by Abel and Jacobi. In general it is to be expected that every differential equation defines a transcendental function; it is the theory of these transcendentals which constitutes properly the most important portion of the theory of differential equations.

In order fully to understand the properties of functions it has been found necessary to look upon the variable as being capable of assuming not only all real but also all complex values. In the hands of Cauchy, Riemann, Weierstrass there has grown up in this way the *theory of functions of a complex variable* (q.v.). This theory serves as a base for our further discussions. We shall, however, confine ourselves to a few of the simplest cases, merely indicating the general point of view.

Let

$$\frac{dy}{dx} = f(x, y)$$

be the given differential equation: Let  $f(x, y)$  be analytic in the vicinity of  $(x_0, y_0)$  i.e., let it be possible to develop  $f(x, y)$  into a series proceeding according to positive integral powers of  $x - x_0$  and  $y - y_0$ . Then, as was first proved by Cauchy, there exists a function  $y$  of  $x$  which may be developed according to positive integral powers of  $x - x_0$ , which reduces to  $y = y_0$  for  $x = x_0$ , and which satisfies the differential equation. This theorem, which may be easily generalized to apply to equations of higher order, or to systems of equations of the first order, is generally known as the fundamental theorem of the theory of differential equations. It proves the existence of analytic functions which are uniquely defined as solutions of analytic differential equations and which satisfy the subsidiary condition of reducing to given values for a given value of the argument. The theorem may be proved by the method of dominating functions. This consists in finding a series which formally satisfies the differential equation and reduces to  $y_0$  for  $x = x_0$ ; its convergence is then demonstrated by comparing it term for term with a corresponding series, which is formed in the same way from another differential equation, and which is known to be convergent. The exact circle of convergence cannot, however, be generally stated. A great many papers have been written on questions which easily suggest themselves in connection with this theorem. If the function  $f(x, y)$  is not developable in the given form; if, for example, its development contains negative or fractional exponents, how far are its solutions determined and what is the form of their developments? Besides the analytic solutions whose existence Cauchy has demonstrated, are there other non-analytic solutions? The first investigations of these questions are due to Briot and Boquet. They have since been completed by a great many authors.

Cauchy's existence theorem can be made more precise in the case of linear differential equations. Let

$$(27) \quad \frac{d^ny}{dx^n} + p_1 \frac{d^{n-1}y}{dx^{n-1}} + \dots + p_n y = 0$$

be a homogeneous, linear differential equation of the  $n$ th order. In the vicinity of  $x = x_0$  let the coefficients  $p_k$  be expressible as power-series, proceeding according to positive integral powers of  $x - x_0$ , and convergent for all values of  $x$  for which  $|x - x_0| < r$ , where  $r$  is a real positive quantity, i.e., for all points of the plane of the complex variable which are within a circle of radius  $r$  and of center  $x_0$ . Then there exists a function  $y$  of  $x$ , expressible as a power series convergent in the same domain, which satisfies the differential equation, and which, together with its first  $n - 1$  derivatives, assumes arbitrarily prescribed values for  $x = x_0$ .

The proof of this theorem, due to Fuchs, is also based on the method of dominating functions. The important point is the fact that the true radius of convergence of the series is determined by inspection from the differential equation itself. The existence of a fundamental system of solutions expressible by power-series follows at once.

Let  $y_1, \dots, y_n$  be the members of such a fundamental system. Let  $a_1, \dots, a_m$  be the singular points (poles) of the coefficients  $p_1, \dots, p_n$  which we shall assume to be rational functions of  $x$ . Let  $\bar{y}_1, \dots, \bar{y}_n$  be continued analytically along a path passing, in the positive direction, around one of these singular points  $a$ , and let  $\bar{y}_1, \dots, \bar{y}_n$  be the new branches of the functions  $y_1, \dots, y_n$  which are thus defined by power-series in the vicinity of  $x = x_0$  after this process. We must have

$$(28) \quad \bar{y}_k = a_{k1}y_1 + a_{k2}y_2 + \dots + a_{kn}y_n, \quad (k=1, 2, \dots, n),$$

where  $a_{ki}$  are constants, since  $\bar{y}_1, \dots, \bar{y}_n$  must constitute again a system of solutions (moreover a fundamental system). A new fundamental system may be chosen in the following manner. Put

$$z = c_1y_1 + c_2y_2 + \dots + c_ny_n,$$

where  $c_1, \dots, c_n$  are constant coefficients. After the continuation around  $a$ ,  $z$  will be changed into

$$\bar{z} = c_1(a_{11}y_1 + \dots + a_{m1}y_m) + \dots + c_n(a_{n1}y_1 + \dots + a_{nn}y_n).$$

This will be equal to  $\omega z$ , where  $\omega$  is a constant, if

$$c_1(a_{11} - \omega) + c_2a_{21} + \dots + c_n a_{n1} = 0, \\ c_1a_{12} + c_2(a_{22} - \omega) + \dots + c_n a_{n2} = 0,$$

(29)

$$c_1a_{1n} + c_2a_{2n} + \dots + c_n(a_{nn} - \omega) = 0,$$

whence

$$(30) \quad F(\omega) = \begin{vmatrix} a_{11} - \omega & a_{21} & \dots & a_{n1} \\ a_{12} & a_{22} - \omega & \dots & a_{n2} \\ \dots & \dots & \dots & \dots \\ a_{1n} & a_{2n} & \dots & a_{nn} - \omega \end{vmatrix} = 0.$$

If  $\omega_1$  is a root of (30) and the ratios of  $c_1, \dots, c_n$  are determined from (29) after  $\omega$  has been put equal to  $\omega_1$ , we shall therefore find a solution  $z_1$  of (27) which changes into  $\omega_1 z_1$  when the variable  $x$  describes a closed path around the singular point considered. If the equation  $F(\omega) = 0$  has  $n$  distinct roots, we shall find  $n$  such solutions, and we may write

$$(31) \quad \bar{z}_i = \omega_i z_i, \quad (i=1, 2, \dots, n)$$

in place of (28). Moreover, these  $n$  solutions  $z_1, \dots, z_n$  will constitute a fundamental system. We shall not attempt to discuss the case of coincident roots of the equation (30), which is known as the *fundamental* or *characteristic* equation.

Now the function

$$(x-a)r_i = e^{r_i \log(x-a)}, \quad r_i = \frac{1}{2\pi i} \log \omega_i$$

has precisely the same property. Therefore the

quotient  $\frac{z_i}{(x-a)r_i}$  is a function uniform in the

vicinity of  $x = a$ , and therefore expressible by a so-called Laurent series proceeding according to positive and negative but integral powers of  $x - a$ . Let  $\phi_i(x)$  be such series; then we have

$$(32) \quad z_i = (x-a)r_i \phi_i(x), \quad (i=1, 2, \dots, n).$$

The Laurent series will be convergent for all points, excepting  $a$  itself, of the circle which has  $a$  as center and which reaches up to the nearest singular point of the differential equation. The main questions to solve are: 1st. Determine the exponents  $r_i$ ; 2d. Find the coefficients of the Laurent series  $\phi_i$ . These questions are capable of a direct and general solution in the special case in which the Laurent series contains only a finite number of terms involving negative



powers of  $x-a$ . In that case the differential equation (27) may be written in the form.

$$(33) \frac{d^2y}{dx^2} + \frac{P_1(x)}{x-a} \frac{d^{n-1}y}{dx^{n-1}} + \frac{P_2(x)}{(x-a)^2} \frac{d^{n-2}y}{dx^{n-2}} + \dots + \frac{P_n(x)}{(x-a)^n} y = 0,$$

where  $P_1, P_2, \dots, P_n$  are expressible as power-series proceeding according to *positive*, integral powers of  $x-a$ . The exponents  $r_i$  are then the roots of the *determining fundamental equation* of the  $n$ th degree

$$(34) r(r-1) \dots (r-n+1) + P_1(a)r(r-1) \dots (r-n+2) + \dots + P_n(a) = 0.$$

After  $r_i$  has been obtained from this equation, the method of indeterminate coefficients enables one to find the coefficients of the power-series. In the case of equal roots some of the solutions may contain such terms as  $\log(x-a)$ ,  $\{\log(x-a)\}^2$ , etc.; the general discussion of the various cases which may arise is rather complicated.

The case in which the equation may be written in the form (33) is usually described as that in which the solutions are *regular* about  $x=a$ . If they are regular in the vicinity of each singular point, including  $x=\infty$ , the equation is said to be of the *Fuchsian type*, and may be written as follows:

$$(35) y^{(n)} + \frac{G_{\mu-1}}{\psi} y^{(n-1)} + \frac{G_2(\mu-1)}{\psi^2} y^{(n-2)} + \dots + \frac{G_n(\mu-1)}{\psi^n} y = 0,$$

where  $y', y'', \dots$  denote the derivatives of  $y$  of the first, second order, etc., where

(35a)  $\psi = (x-a_1)(x-a_2) \dots (x-a_m)$ ,  $a_1, \dots, a_m$  and  $\infty$  being the singular points, and where  $G_\lambda$  denotes a polynomial in  $x$  of degree no higher than  $\lambda$ . The most important special case of such an equation is that of the hypergeometric series, the so-called Gauss equation, which is of the second order and has three singular points, 0, 1 and  $\infty$ . Historically, the theory of the Gauss equation, as treated by Riemann, was the origin of the general theory of linear differential equations. A large number of the most important conceptions of the theory of functions are closely connected with this equation. The question of finding the cases in which the general solution is algebraic led Schwarz, Fuchs and Klein to the remarkable algebraic functions which are connected with the five regular solids. This equation also leads to the general theory of automorphic functions, of which the elliptic functions are a special case.

If, in the vicinity of a singular point, the solutions are regular, they may be developed in the manner indicated. The problem of finding the developments of the solution in the vicinity of a point where they are not regular is far more difficult and still awaits a satisfactory general solution. A solution, not regular at  $x=a$ , may have the special form.

$$e^{\Omega(x-a)^\rho} \psi(x),$$

where  $\rho$  is a constant, where  $\psi(x)$  is an ordinary power-series in  $x-a$ , and where

$$\Omega = \frac{a_1}{(x-a)^s} + \frac{a_2}{(x-a)^{s-1}} + \dots + \frac{a_s}{x-a},$$

so that it differs from a regular integral only

by the presence of the factor  $e^\Omega$ . Such an integral, if it exists, is called a *normal integral*. There may also be integrals of a similar form in which, however,  $(x-a)^{1/k}$  appears in place of  $x-a$ , where  $k$  is a positive integer. They are called *subnormal*. The conditions for the existence of normal and subnormal integrals have been investigated, but none of these investigations is as yet in a final form. Considerable progress in the theory of non-regular integrals has been made in recent years by Birkhoff.

It is possible however to change the method of attack. The general theory shows that, in the vicinity of the singular point  $x=a$ , a solution exists of the form  $(x-a)^\rho \phi(x)$ , where  $\phi(x)$  is, in general, a Laurent series. The question is this: how to determine the exponent  $\rho$  and the coefficients of  $\phi(x)$ . In the regular case, when  $\phi(x)$  is an ordinary power-series, substitution of this expression into the differential equation, and comparison of powers of  $x-a$ , solves the problem. One may do the same thing in general. But then one finds it necessary to solve a system of linear equations infinite in number and with an infinity of unknown quantities. This leads to the notion of *infinite determinants*, due primarily to G. W. Hill. Hill applied infinite determinants just as though they were finite, paying no attention to convergence or rigorous definitions. This deficiency was made up and the whole theory placed upon a solid basis by Poincaré and Koch.

The theory of linear differential equations has served as a basis for practically all that is known about non-linear equations. There are two fundamental properties of the linear equations which render them peculiarly accessible. In the first place it is known, *a priori*, how the arbitrary constants enter into the expression of its general integral; in the second place the singular points of its solutions are *fixed*, i.e. independent of the constants of integration. Other classes of differential equations may be defined which have one or both of these properties. The first-mentioned point of view leads to the differential equations with fundamental solutions. These may be defined in various ways and have been investigated by Guldberg, Vessiot, Lie and Wilczynski. The idea of investigating the differential equations with fixed branch-points is due to Fuchs. For equations of the first order he succeeded in formulating the conditions in a very simple theorem. Poincaré then showed that all such equations can be transformed into a Riccati equation, i.e., an equation of the form

$$(36) \frac{dy}{dx} = a_0 + a_1 y + a_2 y^2,$$

where  $a_0, a_1, a_2$  are functions of  $x$ , or else are integrable by quadratures or algebraic functions. Differential equations of the first order with fixed branch-points do not, therefore, as was at first expected, lead to new transcendental functions. For, the Riccati equation may, by the

transformation  $y = -\frac{1}{a_2} \frac{dz}{dx}$ , be converted into a

linear differential equation of the second order. It may be noted, incidentally, that this remark enables us to prove, in a simple manner, the theorem that the anharmonic ratio of any four

solutions of a Riccati equation is constant. This is important in geometric applications.

The most important recent investigations in the theory of differential equations, from the standpoint of the theory of functions of a complex variable, are due to Painlevé. A brief account of some of them will indicate their fundamental nature. Let

$$(37) \quad \frac{dy}{dx} = f(x, y)$$

be an algebraic differential equation of the first order. The general integral will be a function of  $x$  and  $u$ ,  $u$  being the constant of integration. We may, instead, consider  $u$  as a function of  $x$  and  $y$  defined by the partial differential equation

$$(38) \quad \frac{\partial u}{\partial x} + \frac{\partial u}{\partial y} f(x, y) = 0.$$

The general integral of (37) is said to be *reducible* if other equations, algebraic in  $x, y, u, \frac{\partial u}{\partial x}, \frac{\partial u}{\partial y}, \frac{\partial^2 u}{\partial x^2}$ , etc., may be adjoined to (38) compatible with it without being deducible therefrom. All of the equations of the first order which have been studied are reducible in this sense; for instance, the Riccati equation, the linear equation, etc. In the case of a linear

equation the condition  $\frac{\partial^2 u}{\partial y^2} = 0$  may be thus ad-

joined; if the equation admits an algebraic integrating factor  $\lambda$ , we may adjoin the condition  $\frac{\partial u}{\partial y} = \lambda$ ; etc. This definition of reducibility

may be extended to equations, or systems of equations, of any order.

Applied to equations of the first order, the following theorem results. If an equation of the first order is reducible, only four cases are possible: 1st, the equation is algebraically integrable; 2d, it has an algebraic integrating factor; 3d, the logarithm of the integrating factor has algebraic first derivatives; 4th, a first integral is given by a system of differential equations whose general solution is of the form

$$u = \frac{au_1 + b}{cu_1 + d}, \quad (a, b, c, d \text{ being arbitrary constants,})$$

and which may be reduced to a Riccati equation.

Irreducible equations of the first order lead to known results, if we confine ourselves to the case that  $y$  shall be a uniform function of  $x$ . This is not the case, however, for equations of higher order. Among the equations of the second order, the simplest case is that of the equation

$$(39) \quad y'' = 6y^2 + x.$$

Its general integral is a uniform function of  $x$ , which may be represented as a quotient of two integral transcendental functions in the form  $y = \frac{d^2 \log u}{dx^2}$ , where  $u$  is an integral trans-

cendental function which satisfies the equation

$$(40) \quad \frac{1}{2} (z'')^2 + 2(z')^2 + xz' - z = 0,$$

where  $z = \frac{u'}{u}$ , and which may, therefore, be represented by an ordinary power-series convergent for all values of  $x$ .

Although great progress has been made in

this direction and although greater progress is to be expected as the efforts of mathematicians are being gradually rewarded, the results are meager from the point of view of the mathematical physicist, who would like to refer to the mathematician the questions connected with the integration of a differential equation which may have appeared in some of his investigations. For very rarely will it happen that such an equation belongs to one of the classes with which the mathematician is prepared to deal. It remains necessary to study such equations directly by methods of successive approximation especially adapted to them, usually upon the assumption that all of the variables that enter be confined to real values. The restriction to real variables in such cases, the systematic and rigorous application of the method of successive approximations, has been productive of many valuable results in recent years, especially in the hands of Picard and Hilbert. The theory of partial differential equations, primarily, has made rapid progress through their efforts and many mathematicians are following their example. It may, however, be predicted that, even in the theory of partial differential equations, the restriction to real variables will gradually pass away. For in the case of analytic functions, and these after all are the most important, the characteristic properties are veiled by such a restriction. But a necessary prerequisite for a theory of partial differential equations with complex variables is the theory of functions of several complex arguments; this theory, however, is still in its infancy.

**Bibliography.**—A. R. Forsyth, 'A Treatise on Differential Equations' (3d ed., London 1903). This contains an account of the more elementary parts of the theory. A. R. Forsyth, 'Theory of Differential Equations' (6 vols; Cambridge 1890). In this work the main stress is laid upon the functiontheoretic point of view. S. Lie, 'Vorlesungen über Differentialgleichungen mit bekannten infinitesimalen Transformationen,' bearbeitet und herausgegeben von G., Scheffers (Leipzig 1891). E. Picard, 'Traité d'analyse' (Vols. 2 and 3; Paris 1893-95). Important principally for the modern theory of partial differential equations. P. Painlevé, 'Leçons sur la théorie analytique des équations différentielles, professées à Stockholm,' Sept., Oct., Nov., 1895. Lithographed at Paris, 1897, an account of the most advanced points of view. L. Schlesinger, 'Handbuch der Theorie der linearen Differentialgleichungen' (Leipzig 1895-98). For further bibliographical indications and for a brief account of the whole subject from the point of view of the expert mathematician, see the various articles on differential equations in 'Encyclopädie der mathematischen Wissenschaften mit Einschluss ihrer Anwendungen,' which is now being published in Leipzig. A French edition, much more extensive than the German edition, of this monumental work is also being published.

ERNEST J. WILCZYNSKI,  
Professor of Mathematics, University of Chicago.

**EQUATIONS, Galois' Theory of.**—In the 16th century the Italian mathematicians succeeded in solving the cubic and biquadratic equations. Their brilliant achievements must have made it seem probable that the solution

of the equations of fifth and higher degrees would soon be found. Such, however, was not to be the case. For two centuries the first mathematicians of the day essayed in vain to solve the quintic. Tschirnhausen, Euler, Vandermonde, Malfatti and Lagrange embodied their researches in valuable memoirs, but at the close of the 18th century the solution of the equation of the fifth degree seems farther away than ever.

In their apparent defeat, however, lay the germs of ultimate victory. As a result of all these investigations it became manifest that the solution of algebraic equations and certain groups of substitutions of their roots were intimately related. In the case of the general equations of degrees three and four this relation was very clear indeed; it was less clear in regard to the general equation of degree  $n$ , and still more hazy in regard to the special equations which had been considered up to that time. It was reserved to Evareste Galois to put these loose ends together and to develop a theory of the solution of algebraic equations at once simple and far-reaching. Indeed, the ideas of Galois are not only fundamental in most algebraic investigations, but they have also been extended by Lie and others with great effect to the theory of differential equations. But even here they do not stop. It is in Galois' theory that the notion of a group first came prominently before the mathematical public; a notion which to-day pervades a good part of the whole domain of mathematics.

Galois died at the age of 22 (1832). Twice he presented memoirs to the Paris Academy, containing an account of his theory. The first was lost, the second was returned to its youthful author by Poisson as unintelligible. Galois' theory was first made public to the mathematical world in 1846 when Liouville published this latter memoir without comments. In 1858 Betti published an exposition of Galois' theory with complete proofs and some valuable extensions.

Lagrange in his great memoir of 1770-71 developed what he styled a *calcul des combinaisons* and which is in fact the origin of Galois' Theory of Equations. This new *calcul* was further developed in a number of papers by Ruffini, beginning 1799, who tried to demonstrate the impossibility of the algebraic solution of the general equation of degrees greater than four by this means; by Gauss (1801) and Lagrange (1808) in the solution of the equations on which the roots of unity depend; and finally by Abel, who, besides being the first to rigorously demonstrate the insolubility of the quintic by radicals (1826), discovered a new class of algebraic solvable equations which occur in the division of the elliptic functions (1829).

**BASAL NOTIONS.**

**Domain of Rationality.**—One of the most fundamental notions in Galois' theory is that of a domain of rationality which was first clearly formulated by Abel. When an equation

$$f(x) = ax^n + a_{1x}x^{n-1} + \dots + a_n - x + a_n = 0 \quad (1)$$

offers itself for solution, its coefficients are supposed known. It often happens that other quantities are known, or are assumed as known. Suppose  $\lambda, \mu, \dots, \omega$  are such quantities, finite in number. The totality of rational functions of

these letters with rational numbers as coefficients constitutes a domain of rationality which we denote by,

$$R(\lambda, \mu, \dots, \omega).$$

Thus any element of this domain may be obtained by a finite number of additions, subtractions, multiplications and divisions performed on the letters  $\lambda, \mu, \dots, \omega$ . The domain of rationality which we lay at the base of a given algebraic investigation is to some degree a matter of choice. In any case, however, the coefficients of the equations we start with should lie in it.

Every domain must contain the domain  $R(1)$ , called the absolute domain, and which is simply the totality of rational numbers. For the domain  $R(\lambda, \dots, \omega)$  must contain the element  $\lambda/\lambda = 1$ . It is often desirable to add certain elements  $\eta, \zeta, \dots$  to a domain  $R(\lambda, \mu, \dots)$  forming the new domain  $R'(\lambda, \mu, \dots, \eta, \zeta, \dots)$ . The elements  $\eta, \zeta, \dots$  are said to be *adjoined* to  $R$ .

**Rational Functions in R.**—In elementary algebra and in the function theory a rational function of  $x, y, z, \dots$  is an expression of the form

$$\frac{Ax^m y^n z^p \dots + \dots}{Bx^n y^m z^p \dots + \dots} \quad (2)$$

where the exponents  $m, n$  are non-negative integers and the coefficients are merely independent of the variables  $x, y, z, \dots$ . In Galois' theory the term rational function is a much narrower one. In fact the term rational has no meaning unless in connection with a specific domain of rationality. Thus the expression (2) is a rational function of  $x, y, \dots$  in Galois' theory with respect to the domain  $R$ , when and only when the coefficients  $A, B, \dots$  lie in  $R$ . Thus such a function as (2) may be rational with respect to one domain and not with respect to another. For example

$$x + \sqrt{-3}y.$$

is a rational function of  $x, y$  with respect to the

domain  $R(\rho), \rho = e^{\frac{2\pi i}{3}}$ ; but it is not rational with respect to  $R(1)$  or  $R(\sqrt{-5})$ . When the denominator in (2) reduces to a constant, it becomes a rational *integral* function.

An equation as (1) is *rational* with respect to  $R$  when its coefficients  $a_0, a_1, \dots, a_n$  lie in  $R$ .

**Reducibility and Irreducibility.** is another basal notion of Galois' theory. The rational integral function of  $x, y, z, \dots$ ,

$$F(x, y, z, \dots) = Ax^m y^n z^p \dots + \dots + Lx^l y^m z^p \dots, \quad (3)$$

with respect to the domain  $R$  is *reducible* in  $R$  when it is the product of two or more rational integral functions of  $x, y, \dots$  with coefficients in  $R$ , viz.,  $F = G \cdot H \cdot I \dots$ . In this case we say  $F$  is divisible by  $G, H, \dots$ , which are factors or divisors of  $F$  in the domain  $R$ . If the expression (3) cannot be split up into two such factors, it is *irreducible* with respect to  $R$ . An equation as (1) is reducible or irreducible in  $R$  according as its left side is reducible or irreducible in  $R$ .

An equation as (1) may be irreducible in one domain and reducible in another. Thus

$$x^3 + x + 1 = 0$$

is irreducible in  $R(1)$ , but is reducible in  $R(\sqrt{-3})$ . In fact,

$$x^3 + x + 1 = (x - \rho)(x - \rho^2), \quad \rho = e^{\frac{2\pi i}{3}}$$

If  $\xi_1, \dots, \xi_n$  are the roots of (1), it is obviously reducible in  $R$  ( $\xi_1, \dots, \xi_n$ ). In fact its left side splits up into rational lineal factors,

$$f(x) = a_0(x - \xi_1) \dots (x - \xi_n).$$

A theorem of utmost importance in Galois' theory is the following:

Let  $f(x) = 0, g(x) = 0$  be rational equations for the domain  $R$ , and let  $f(x) = 0$  be irreducible in  $R$ . If  $g(x) = 0$  admits a root of  $f(x) = 0$ , it admits all the roots of  $f(x) = 0$ , and  $g(x)$  is divisible by  $f(x)$ .

**Equality.**—As a third pillar on which Galois' theory rests is the distinction between formal and numerical equality, as we may designate it for lack of better terms. It is only by such a distinction that Galois was able to extend Lagrange's methods so as to apply to any type of algebraic equation. As long as we are dealing with constants, equality and inequality are of course the same as in arithmetic—they are numerical. What do we mean, however, by the equation

$$\phi(p, q, \dots) = \psi(p, q, \dots),$$

$\phi, \psi$  being rational functions of the variables  $p, q, \dots$  for a domain  $R$ ? In general  $R$  will contain variable elements which then may enter the coefficients of  $\phi, \psi$ . Let us write the above equation

$\phi(v_1, v_2, \dots, c_1, c_2, \dots) = \psi(v_1, v_2, \dots, c_1, c_2, \dots)$ , where  $v_1, v_2$  represent now all the variable elements in  $\phi, \psi$ , among which will be  $p, q, \dots$ , while  $c_1, c_2, \dots$  represent constants. By an equation of the above type we mean: that for each and every set of numerical values  $v_1, v_2, \dots$  can take on consistent with their definition, the resulting numerical value of  $\phi$  is identical with that of  $\psi$ .

When no two of the quantities  $\phi, \psi, \chi, \dots$  are equal we shall call them distinct or unequal.

THE GALOISIAN RESOLVENT AND GROUP.

**Construction of  $n!$ -valued Functions; Indeterminants.**—Let

$$f(x) = a_0x^n + a_1x^{n-1} + \dots + a_n = 0 \quad (1)$$

be an equation whose solution is to be effected. The first thing to do is to choose a domain of rationality  $R$ . As already remarked, the nature of  $R$  depends partly upon (1) and partly upon our own pleasure. In any case it must contain the coefficients.

Without loss of generality we may suppose its roots unequal. For by means of the greatest common divisor of  $f(x)$  and  $f'(x)$  we may obtain by rational operations an equation whose roots are the distinct roots of (1).

Let us now adjoin  $n$  new variables  $u_1, \dots, u_n$  to  $R$ , forming a domain  $R'$ , and introduce the rational function

$$V_1 = u_1x_1 + u_2x_2 + \dots + u_nx_n. \quad (4)$$

If we permute the  $x_1, x_2, \dots, x_n$  in all possible ways, or, as we say, apply the  $n!$  substitution

$$\begin{pmatrix} x_1 & x_2 & \dots & x_n \\ x_{i_1} & x_{i_2} & \dots & x_{i_n} \end{pmatrix}$$

of the symmetric group, we get the  $n!$  functions  $V_1, V_2, \dots, V_{n!}$ . (5)

With these we form the equation  $F(t; u_1, \dots, u_n) = (t - V_1)(t - V_2) \dots (t - V_{n!}) = 0$ , (6) whose coefficients lie in  $R'$ . In the discriminant of (6),  $D(u_1, \dots, u_n)$ , we may give to  $u_1, \dots, u_n$  values,  $a_1, \dots, a_n$ , in  $R$ , integral values,

even, if we choose, in an infinity of ways so that  $D \neq 0$ . In that case the quantities (5) are distinct and the roots of (6) thus unequal. The function (4) has thus  $n!$  values under the symmetric group. A special case of this function (4) was used by Lagrange; in its general form it was first employed by Abel. Its fundamental importance in the solution of algebraic equations was first brought out by Galois. For this reason the function  $V$  in (4) is called the Galoisian resolvent function. Besides the function (4) there are obviously an infinity of other  $n!$ -valued functions. The function (4) is employed on account of its simplicity.

On replacing the  $u$ 's by the  $a$ 's these variables disappear. Their introduction was to show the existence of  $n!$ -valued rational functions of the roots  $x_1, \dots, x_n$ . Such auxiliary variables which we introduce into our reasoning, and which at any moment can be made to disappear by giving them appropriate special values, are called *indeterminates*. In a primitive way they are used by all mathematicians. Kronecker has shown that they are an implement of immense power in algebraic investigations. Since in the end we can always replace the indeterminates by values lying in our domain, we shall suppose that our domain contains in advance as many of these auxiliary variables as we care to use.

**Galoisian Resolvent and Group.**—In general the equation (6) is reducible in  $R$ , so that

$$F(t) = G_0(t, u_1, \dots, u_n) G_1(t, u_1, \dots, u_n) \dots$$

Let us take now any one of these irreducible factors, say that one which admits  $V_1$  as root, to form the equation

$$G_0(t, u_1, \dots, u_n) = 0. \quad (7)$$

This is called the Galoisian Resolvent of (1) for the domain  $R$ . Let its degree in  $t$  be  $m$ .

Galois showed now that the solutions of (1) and (7) are equivalent problems. In fact every rational function of the roots of (1), and in particular the roots themselves and hence also the roots  $V_1, V_2, \dots, V_m$  of (7), are rational functions of  $V_1$ . We have therefore for any rational function of the  $x$ 's

$$\phi(x_1, \dots, x_n) = r_0 + r_1V_1 + r_2V_1^2 + \dots + r_{m-1}V_1^{m-1}.$$

The advance that is made by considering the equation (7) instead of the original equation (1) lies in the fact that the roots of (7) are rational in any one of them. Let the roots of (7) be

$$V_1, V_2, \dots, V_m.$$

These are obtained from the expression (4) by effecting certain substitutions,

$$s_1 = 1, s_2, \dots, s_m, \quad (G)$$

on the roots  $x_1, \dots, x_n$ . These  $m$  substitutions  $G$  enjoy now three remarkable properties:

- 1° Every rational function  $\phi(x_1, \dots, x_n)$  of the roots of (1) which remains unaltered by  $G$  lies in  $R$ , or, as we say, is rationally known.
- 2° If the rational function of the roots  $\phi(x_1, \dots, x_n)$  is rationally known, it remains unaltered for the substitutions  $G$ .
- 3° The substitutions  $G$  form a group, and there is no other group of substitutions having the properties 1°, 2°.

This group is called the Galoisian group of the equation (1) for the domain  $R$ . For the definition of the various terms concerning groups see GROUPS, THEORY OF. The index of a sub-group  $H$  of a group  $G$  with respect to  $G$  is the ratio between the number of terms in  $H$

and the number of terms in  $G$ . We say for the domain  $R$ , because by changing  $R$  the irreducible factors of (6) will in general change, and therefore the substitutions  $G$  will in general change. The importance of the Galoisian group, or, as we shall say more shortly, the Group, of an equation  $f(x) = 0$  lies in the fact that an investigation of its structure reveals many of the most important properties of the algebraic irrationalities defined by this equation. In particular it affords a rational and uniform scheme for effecting the solution of any algebraic equation. Before entering on this topic let us consider

SOME PROPERTIES OF THE GALOISIAN GROUP  $G$ .

Since the group  $G$  of an equation

$$a_n x^n + a_{n-1} x^{n-1} + \dots + a_0 = 0 \tag{1}$$

is unique for a given domain of rationality  $R$ , it follows: 1° that the group is independent of the particular  $n!$ -valued function we take; 2° that we get the same group whichever of the irreducible factors  $G_0(t), G_1(t), \dots$  of (6) we may choose; and 3° that these functions  $G_0, G_1, \dots$  are all of the same degree.

4°. In any rational equation

$$\phi(x_1, \dots, x_n) = \psi(x_1, \dots, x_n)$$

between the roots of (1) the substitutions of  $G$  may be applied, and the result is a true equation.

This is not true for all substitutions. For example, let

$$f(x) = x^3 - 1 = 0,$$

whose roots are

$$x_m = e^{\frac{2\pi im}{3}}, \quad m = 0, 1, 2.$$

Take as domain  $R(1)$ , and as rational relation

$$x_1 x_2 = 1.$$

On applying the substitution

$$\begin{pmatrix} x_1 x_2 \\ x_1 x_3 \end{pmatrix} = (0, 1, 2)$$

this relation becomes,

$$x_1 x_2 = 1,$$

which is false.

Group Belonging to a Rational Function of the Roots and Rational Functions Belonging to a Group.—Let

$$\phi(x_1, \dots, x_n)$$

be a rational function of the roots of (1). Since the group  $G$  of (1) contains the identical substitution,  $\phi$  remains unaltered by at least one substitution of  $G$  and may remain unaltered by others. These substitutions form a subgroup of  $G$  called the group belonging to  $\phi$ . On the other hand, let  $H$  be a subgroup of  $G$ . Any rational function  $\phi(x_1, \dots, x_n)$  which remains unaltered by the substitutions of  $H$  but is changed by all other substitutions of  $G$  is said to belong to  $H$ . It is important to note that while the substitutions of the Galoisian group which leave a rational function  $\phi(x_1, \dots, x_n)$  unaltered form a group, this property does not hold for substitutions which lie outside  $G$ . For example, the substitutions of the symmetric group  $S_n$  which leave

$$\phi = x_1 x_2, \quad x_m = e^{\frac{2\pi im}{5}}, \quad m = 0, 1, 2, 3, 4, 5,$$

do not form a group. This is due to the fact that the group of the equation  $x^5 - 1 = 0$ ,

the domain being  $R(1)$ , is not  $S_5$  but a smaller group.

If  $\phi(x_1, \dots, x_n), \psi(x_1, \dots, x_n)$  belong to the same subgroup  $H$  of the Galoisian group, each can be expressed rationally in terms of the other.

RATIONAL RESOLVENTS.

Let  $\phi(x_1, \dots, x_n)$  be a rational function of the roots of

$$a_n x^n + a_{n-1} x^{n-1} + \dots + a_0 = 0, \tag{1}$$

whose group for the domain  $R$  is  $G$ . Let  $\phi$  belong to a subgroup  $H$  of  $G$  of index  $r$ . Then on applying the substitutions of  $G$  to  $\phi$  it will take on  $r$  distinct values,

$$\phi, \phi_1, \dots, \phi_{r-1}, \tag{8}$$

which are called conjugate functions. They are in fact roots of an irreducible equation

$$\Phi(y) = (y - \phi)(y - \phi_1) \dots (y - \phi_{r-1}), \tag{9}$$

whose coefficients lie in  $R$ . It is thus a rational equation. Suppose one of its roots, say  $\phi$ , can be found. If we adjoin it to  $R$ , forming a domain  $R'$ , the group of (1) is no longer  $G$ , but  $H$ .

Suppose not only  $\phi$  but all the roots of (9) can be found. Their adjunction to  $R$  forms a domain  $R''$  for which the group of (1) is the greatest invariant subgroup of  $G$  contained in  $H$ . In any case the adjunction of one or more roots of (9) produces a reduction of the group of the given equation (1). But in reducing the group of this equation we have made a step in its solution. For when the domain of rationality has been enlarged to such an extent that the group of the equation (1) embraces only the identical substitution, the roots of (1) are rationally known, that is, can be expressed rationally in terms of quantities lying in that domain of rationality. The equation (9) is called a resolvent equation, or more specifically a rational resolvent, since its roots  $\phi, \phi_1, \dots$  are rational functions of the roots of a given equation (1).

The group of the resolvent equation (9) is of importance sometimes. In the functions (8) considered as functions of the  $x$ 's, let us effect the substitutions of the group  $G$ . This gives rise to a substitution group  $\Gamma$  in the  $\phi$ 's, and this group is the group of the resolvent equation (9), the domain of rationality being that of  $G$ , viz.,  $R$ . The groups  $G$  and  $\Gamma$  are what is called meroedrically isomorphic. To the identical substitution of  $\Gamma$  corresponds the group  $I$  above mentioned, viz., the subgroup of  $G$ , which leaves all the roots (8) unaltered. To any subgroup  $\Gamma_1$  of  $\Gamma$  will correspond a subgroup  $G_1$  of  $G$ , and conversely. In particular if  $\Gamma_1$  is an invariant subgroup,  $G_1$  is also invariant.

GALOIS' SOLUTION OF AN EQUATION.

Let  $G$  be the group of the equation

$$a_n x^n + a_{n-1} x^{n-1} + \dots + a_0 = 0 \tag{1}$$

for the domain  $R$ . Let  $H_1$  be a subgroup of  $G$  of index  $r_1$ . Let  $\phi_1(x_1, \dots, x_n)$  be any one of the infinity of rational functions belonging to  $H_1$ . Then  $\phi_1$  is root of a rational resolvent  $\Phi_1(y) = 0$  of degree  $r_1$ . On solving  $\Phi_1 = 0$  and adjoining one or more of its roots to form a new domain  $R_1$ , the group of (1) is now a subgroup of  $G_1$  of  $G$ . Let  $H_2$  be a subgroup of  $G_1$  of index  $r_2$ , to which belongs the rational function  $\phi_2(x_1, \dots, x_n)$ . This is the root of a re-

solvent  $\phi_2(y) = 0$  of degree  $r_2$ . On solving  $\phi_1 = 0$  and adjoining one or more of its roots to form a new domain  $R_2$ , the group of (1) is now a subgroup  $G_2$  of  $G_1$ . As the order of the groups  $G, G_1, G_2$ , decreases, we must eventually arrive at the identical group when the roots of (1) are rationally known. Since the group  $G$  usually admits quite a variety of subgroups, and since the functions  $\phi$  belonging to a given subgroup are infinite in number, Galois' theory shows that the number of ways for solving a given equation is endless. At the same time it clearly shows that the number of distinct ways is usually quite limited, depending on the subgroups of  $G$ .

Among the solutions of the equation (1) which Galois' theory offers, one class is particularly interesting, depending on a

**Series of Composition.**—This is defined as follows: Let  $G_1$  be an invariant subgroup of  $G$ , such that  $G$  contains no invariant subgroup containing  $G_1$ . It is then a *maximum invariant* subgroup of  $G$ . If  $G$  has no maximum invariant subgroup besides the identical group, it is *simple*. The series of groups

$$G, G_1, G_2, \dots, G_\lambda = 1, \tag{10}$$

such that each is a maximum invariant subgroup of the preceding group, is called a *series of composition* of  $G$ . If the index of  $G_m$  under  $G_{m-1}$  is  $r_m$ , the numbers  $r_1, r_2, \dots, r_\lambda$  are called the *factors of composition*. It may be possible to decompose a group  $G$  into a series of composition in more than one way. Thus the cyclic group  $C_6$ ,

$$1, s, s^2, s^3, s^4, s^5,$$

where  $s = \begin{pmatrix} x_1 x_2 x_3 x_4 x_5 x_6 \\ x_2 x_3 x_4 x_5 x_6 x_1 \end{pmatrix} = (1, 2, 3, 4, 5, 6)$  admits the series

$$C_6, A, 1$$

and

$$C_6, B, 1,$$

where

$$A = \{1, s^2, s^4\}, \quad B = \{1, s^3\}.$$

The factors of composition of the first series are 2, 3, while those of the second series are 3, 2. They are thus the same aside from their order. A theorem of Jordan states that *however a group be decomposed in a series of composition, the factors of composition are the same aside from their order*.

What makes the solution of an equation by means of a series of composition so remarkable is the fact that the resolvents  $\phi_1 = 0, \phi_2 = 0, \dots, \phi_\lambda = 0$  corresponding to the subgroups  $G_1, G_2, \dots, G_{\lambda-1}$  of (10) have groups  $\Gamma_1, \Gamma_2, \dots, \Gamma_\lambda$  for their respective domains which are simple. Their orders are the factors of composition. Moreover, any root of one of these equations is a rational function of any root of that equation. Thus on adjoining one of its roots the same effect is produced as adjoining all. Finally, the resolvent equations  $\phi = 0$  are the simplest possible.

**Cyclic Equation of Prime Degree.**—When the group  $G$  of an equation  $F(x) = 0$  is a cyclic group of prime order  $p$  its solution is readily effected, as Abel showed. Let the roots of  $F = 0$  be  $x_0, x_1, \dots, x_{p-1}$ , and let  $\gamma = (0, 1, \dots, p-1)$ . Then

$$G = \{1, \gamma, \gamma^2, \dots, \gamma^{p-1}\}.$$

For the case in hand we may suppose the

$p$ th roots of unity  $\rho, \rho^2, \dots$  lie in the original domain of rationality. Consider the rational functions

$$\theta_h = x_0 + \rho^h x_1 + \dots + \rho^{h(p-1)} x_{p-1}; \quad h = 1, 2, \dots, p-1.$$

On applying  $\gamma$  they go over into  $\rho^{-h}\theta$ . Hence  $\theta_h^p = \theta_h$  are unaltered by  $\gamma$  and hence by  $G$ .

They are therefore rationally known. On extracting a  $p$ th root we get

$$x_0 + \rho^h x_1 + \dots + \rho^{h(p-1)} x_{p-1} = \sqrt[p]{\theta_h}.$$

This system of  $p-1$  equations together with

$$x_0 + x_1 + \dots + x_{p-1} = \sqrt{\theta_0}$$

gives

$$x_s = \frac{1}{p} \sum_{h=0}^{p-1} \rho^{-hs} \sqrt[p]{\theta_h}, \quad s = 0, 1, \dots, p-1.$$

The  $p$ th roots which enter here must be determined uniquely in terms of one of them, say  $\sqrt[p]{\theta_1}$ . The others are rational in this one, for

$$(x_0 + \rho^h x_1 + \dots + \rho^{(p-1)h} x_{p-1})^{p-h} = A_h$$

remains unchanged for  $\gamma$  and hence for  $G$ . Hence these  $A_h$  are rationally known. We have now

$$x_s = \frac{1}{p\theta_1^h} \sum_{h=0}^{p-1} \rho^{-hs} \left(\sqrt[p]{\theta_1}\right)^h A_h.$$

This result gives the theorem: *Cyclic equations of prime degree can be solved algebraically, i.e., by the extraction of roots from known quantities.*

**Algebraic Solution of an Equation.**—Let the equation

$$a_n x^n + a_{n-1} x^{n-1} + \dots + a_0 = 0 \tag{1}$$

have a group  $G$  for a certain domain  $R$ , whose factors of composition

$$r_1, r_2, \dots$$

are all primes. Then (1) can be solved algebraically. For the corresponding chain of resolvents

$$\phi_1 = 0, \phi_2 = 0, \dots$$

have groups of prime orders  $r_1, r_2, \dots$ ; they are therefore cyclic equations, whose solution has just been effected. Since, as will be set forth later at more length, it is never necessary to employ other than rational resolvents, the above results leads to Galois' Criterion for the Solution of an Equation by Radicals. *In order that (1) admit an algebraic solution it is necessary and sufficient that the factors of composition of its Galoisian group consist of primes only.*

*Application to the Solution of the Biquadratic*

$$x^4 + a_1 x^3 + a_2 x^2 + a_3 x + a_4 = 0. \tag{11}$$

For simplicity let us suppose its coefficients are independent variables. Let the original domain of rationality  $R$  embrace besides the coefficients a cube root of unity  $\rho$ . Then the group of (11) is the symmetric group  $S_4$ . As subgroups of  $S_4$  we note the alternate group  $A_4$ , which consists of all the substitutions of  $S_4$ , which can be obtained by an even number of exchanges of the roots of our equation, the axial group  $G_6 = \{1, (12)(34), (13)(24), (14)(23)\}$ , and the semi-axial group  $G_3 = \{1, (12)(34)\}$ . The

groups  $S_4, A_4, G_4, G_2, 1$  form a series of composition whose factors are obviously  
 2, 3, 2, 2.

As they are primes, the equation (11) admits an algebraic solution. To solve (11) let us proceed with Starkweather as follows: To form our first resolvent, let us use the subgroup  $A_4$ , and take as function belonging to this group

$$\phi = (x_1 - x_2)(x_1 - x_3)(x_1 - x_4) \\ (x_2 - x_3)(x_2 - x_4)(x_3 - x_4) \quad (12)$$

The corresponding resolvent is  
 $\Phi = \phi^2 - \Delta = 0,$  (13)

where  $\Delta$  is the discriminant of (11).  
 On adjoining  $\phi = \sqrt{\Delta}$  our domain is  $R_1(R, \sqrt{\Delta})$ , for which the group of (11) is  $A_4$ .

A subgroup of  $A_4$  is  $G_4$ . A rational function belonging to this is

$$\psi = x_1x_2 + x_2x_3.$$

This gives the resolvent  
 $\Psi = \psi^3 - a_1\psi^2 + (a_1a_2 - 4a_4)\psi \\ - \{a_1(a_1^2 - 4a_2) + a_1^2\} = 0.$  (14)

The solution of this cubic, which is a cyclic equation, gives  $\psi$  as a known explicit function of quantities in  $R_1$ . On adjoining  $\psi$  we get the domain  $R_2(R, \sqrt{\Delta}, \psi)$ , for which the group of (11) is  $G_4$ . The next subgroup we take is  $G_2$  to which belongs

$$\chi = x_1 + x_2 - (x_3 + x_4).$$

This gives the resolvent  
 $X = \chi^2 - (4\psi + a_1^2 - 4a_2) = 0.$

The extraction of a square root gives  $\chi$ , whose adjunction produces the domain  $R_3(R, \sqrt{\Delta}, \psi, \chi)$ , for which the corresponding group of (11) is  $G_2$ . The last group we take is the identical group, to which belongs  $x_1$ . The corresponding resolvent is

$$x^2 + \frac{1}{2}(a_1 - \chi)x + \left(\psi + \frac{2a_2 - a_1\psi}{\chi}\right) = 0.$$

The solution of this quadratic gives  $x_1$ . Its adjunction gives the domain  $R_4(R, \sqrt{\Delta}, \psi, \chi, x_1)$  for which the group consists only of the identical substitution. Hence all the other roots of (11), viz.,  $x_2, x_3, x_4$ , must lie in  $R_4$ . This is indeed so, for

$$x_2 = x_1 - \frac{1}{2}\chi_1 + \frac{1}{2}\chi.$$

To get  $x_3, x_4$ , we note that if  $\psi', \psi''$  denote the two other roots of (14),

$$a = \psi' - \psi'' = \frac{(\psi - \psi')(\psi - \psi'')(\psi' - \psi'')}{(\psi - \psi')(\psi - \psi'')}.$$

Here the numerator is the square root of the discriminant of (14), which, as is well known, is the same as the discriminant  $\Delta$  of (11). The

denominator is obviously  $\frac{d\Psi}{d\psi}$ . Thus

$$a = \frac{\sqrt{\Delta}}{\Psi'} = (x_1 - x_2)(x_3 - x_4),$$

a quantity lying in  $R_4$ .  
 Moreover,  $x_1, x_2$  being already found,  $x_1 - x_2 = \beta$  and  $x_1 + x_2 = \gamma$  are known; also  $x_1 + x_2 + x_3 + x_4 = \gamma + x_3 + x_4 = -a_1$  is known. This last with  $\beta(x_3 - x_4) = a$  gives  $x_3$  and  $x_4$ .

Lagrange's Solution instead of employing a series of composition uses the following sub-

groups,  $A_4, O, G_2, 1$ , where  
 $O = \{1, (1324), (13)(24), (1423), (12), (34), (12)(34), (14)(23)\}.$

As rational function belonging to  $A_4$  Lagrange uses the function (12), which gives rise to the resolvent (13). As rational function belonging to  $O$ , Lagrange takes

$$\theta = \{x_1 + x_2 - (x_3 + x_4)\}^2,$$

whose conjugate values are  
 $\theta_1 = \{x_1 + x_3 - (x_2 + x_4)\}^2, \theta_2 = \{x_1 + x_4 - (x_2 + x_3)\}^2.$

The corresponding resolvent is  
 $\Theta = \theta^2 - (3a_1^2 - 8a_2)\theta^2 + (3a_1^4 - 16a_1^2a_2 + 16x_1^2 \\ + 16a_1a_2 - 64a_4)\theta - (a_1^3 - 4a_1a_2 + 8a_2)^2 = 0.$

For the subgroup  $G_2$  he takes  
 $\eta = x_1 + x_2 - (x_3 + x_4),$

which gives the resolvent  
 $H = \eta^2 - \theta_1 = 0.$

For the identical group 1, Lagrange uses  
 $\omega = x_1 + x_2 - (x_3 + x_4),$

which gives the resolvent  
 $\Omega = \omega^2 - \Theta = 0.$

For the domain  $R'(R, \sqrt{\Delta}, \theta, \theta_1, \theta_2, \eta, \omega)$ , the group of the biquadratic is (1), and its roots therefore lie in  $R'$ . In fact we have

$$x_1 + x_2 - x_3 - x_4 = \sqrt{\theta}, \\ x_1 + x_2 - x_3 - x_4 = \sqrt{\theta_1}, \\ x_1 + x_2 - x_3 - x_4 = \sqrt{\theta_2}, \\ x_1 + x_2 + x_3 + x_4 = -a_1.$$

From which we get  
 $x_s = \frac{1}{4}(-a_1 + \sqrt{\theta} + \sqrt{\theta_1} + \sqrt{\theta_2}), s = 1, 2, 3, 4.$

Here we choose at will the signs of  $\sqrt{\theta}, \sqrt{\theta_1}$ . The sign of  $\sqrt{\theta_2}$  is then determined, for

$$\sqrt{\theta} \sqrt{\theta_1} \sqrt{\theta_2} = 4a_1a_2 - a_1^2 - 8a_2.$$

**Abelian Equations.**—Let  $G$  be the group of an equation  $f(x) = 0$  for a certain domain. If the substitutions of  $G$  are commutative, that is,  $f s_i s_k = s_k s_i$  for any two substitutions  $s_i, s_k$  of  $G$ , the equation  $f = 0$  is called Abelian in honor of Abel, who first studied them. We may show at once that every subgroup of  $G$  is invariant and that its factors of composition are all primes. Hence all Abelian equations can be solved algebraically. The most important equations of this type are the equations of degree  $\phi(n)$  on which the  $n$ th roots of unity depend. Here  $\phi(n)$ , called the totient of  $n$ , is

$$n \left(1 - \frac{1}{p}\right) \left(1 - \frac{1}{q}\right) \dots,$$

where  $p, q, \dots$  are the different prime factors of  $n$ . The domain of rationality is  $R(1)$ .

**Equation of Degree  $> 4$ .**—The group of the equation (1) when no restrictions are placed on the coefficients, i.e., when they are independent variables, and when the domain of rationality contains not only the coefficients but any constants, is the symmetric group. When  $n = 2, 3, 4$ , its factors of composition are primes. Not so when  $n > 4$ . In this case its only invariant subgroup besides the identical group is the alternate group whose order is  $\frac{1}{2}n!$ . Thus the factors of composition are  $2, \frac{1}{2}n!$ . The latter is not a prime. We have thus *Abel's Theorem: Equations of degree  $> 4$ , whose group is the symmetric group, cannot be solved*

algebraically; i.e., their roots cannot be found by extracting roots from known quantities.

We have just observed that when the coefficients of an equation of degree  $> 4$  are independent variables, it cannot be solved algebraically. From that we cannot, however, deny that every equation of degree  $> 4$  with constant coefficients may admit an algebraic solution. This important question was finally settled by Hilbert, who showed that there are an infinity of equations of any degree with rational integral coefficients whose group in  $R(1)$  is the symmetric group.

#### IRRATIONAL RESOLVENTS.

Up to the present we have considered the effect on the Galoisian Group of an equation, of adjoining roots of rational resolvents to the current domain of rationality. In many investigations it is important to consider the adjunction of roots of equations which may not be rational functions of the roots of the given equation. Equations whose roots are not rational functions of the roots of the given equation are called *irrational resolvents* when used in the solution of the given equation. A theorem which lies at the foundation of this subject is due to Kronecker. Let  $f(x)=0, g(y)=0$  be two rational irreducible equations for the domain  $R$  of degrees  $m, n$  respectively. If on adjoining a root  $x_1$  of  $f=0, g(y)$  becomes reducible, the adjunction of a root  $y_1$  of  $g=0$ , will make  $f(x)$  reducible. If  $\phi(x), \psi(x)$  of degrees  $\alpha, \beta$ , respectively, be the irreducible factors for the new domains that  $x_1, y_1$  satisfy, then

$$\frac{m}{\alpha} = \frac{n}{\beta}.$$

As an important corollary of Kronecker's theorem we have: Let the adjunction of  $y_1$  reduce the group  $G$  of  $f(x)=0$  to an invariant subgroup of index  $i$ . Then  $n$  is a multiple of  $i$  and hence never less than  $i$ . When  $n=i$  (and this is always the case if  $n$  is a prime)  $g(y)=0$  is a rational resolvent.

Another theorem of great importance in this connection is due to Jordan. If the adjunction of all the roots of  $g(y)=0$  reduces  $G$  to a subgroup  $G_1$  of index  $i$ , the adjunction of all the roots of  $f(x)$  reduces the group  $H$  of  $g(y)$  to a subgroup  $H_1$  of index  $k$ . The two groups  $G_1, H_1$  are invariant and  $i=k$ . Finally, when  $H$  is simple  $g(y)=0$  is a rational resolvent.

**Application to Some Celebrated Problems.**—The Delian Problem or duplication of the cube requires the solution of

$$x^3 - 2 = 0$$

by rule and compass. The construction of the regular polygons by rule and compass is another famous problem of antiquity. Its solution depends upon the irreducible equation of degree  $\phi(n)$  already referred to. That the Delian Problem is impossible follows at once from the theorem: *In order that a root, real or imaginary, of an irreducible equation  $f(x)=0$  can be constructed geometrically it is necessary that the degree of  $f$  be a power of two.* From this theorem we also conclude: *The necessary and sufficient condition that a regular polygon of  $n$  sides can be constructed by rule and compass is that the totient of  $n$  is a power of two.*

Another famous question is the *Casus Irre-*

*ducibilis* of cubic equations. The theory of irrational resolvents enables us to prove readily the following general theorem: *An irreducible equation of degree  $n$  whose roots are all real can never be solved by real radicals alone if  $n$  contains other factors than two.*

That the *casus irreducibilis* is indeed such follows as corollary of this theorem.

**Hölder's Theorem.**—One of the most important and fundamental contributions to Galois' theory in recent years is a theorem of Hölder. Speaking roughly, it asserts that however the solution of a given equation  $f(x)=0$  be conducted, sometime in the course of the solution certain simple equations whose groups are uniquely determined and known in advance must be employed. When the group of  $f(x)=0$  is simple (in which case we say  $f(x)$  is simple) it can be solved by no other simple equation  $g(y)=0$  essentially different from  $f=0$ . The solution of any given equation therefore depends upon a chain of simple equations. But of all simple equations belonging to a given group certain ones will enjoy peculiar properties which will recommend their selection as *normal* equations. The reduction of the given equation to these normal equations is a problem by itself.

#### THE SOLUTION OF THE QUINTIC.

We have seen that the equation of fifth degree  $Q=0$  whose group is the symmetric group cannot be solved by means of radicals, i.e., by resolvents of the type  $x^m - a = 0$ . On adjoining  $(x_1 - x_2)(x_1 - x_3)(x_1 - x_4)(x_1 - x_5)(x_2 - x_3)(x_2 - x_4)(x_2 - x_5)(x_3 - x_4)(x_3 - x_5)(x_4 - x_5)$  the square root of its discriminant  $\Delta$ , the group of  $Q=0$  reduces to the alternate group  $A_5$  of 60 substitutions. But  $A_5$  is simple. Thus  $Q=0$  is a simple equation for the domain  $R(\sqrt{\Delta})$ . Other algebraic equations having this group arise in the theory of linear differential equations, and also in the theory of elliptic functions. In fact the hypergeometric function

$$F(\alpha, \beta, \gamma, x) = 1 + \frac{\alpha \cdot \beta}{1 \cdot \gamma} x + \frac{\alpha \cdot \alpha + 1 \cdot \beta \cdot \beta + 1}{1 \cdot 2 \cdot \gamma \cdot \gamma + 1} x^2 + \dots$$

is a solution of a very simple differential equation of the second order  $G=0$ . For variable  $\alpha, \beta, \gamma$ , it represents a new transcendent; but for certain values of these parameters it reduces to the elementary functions; e.g., it may become algebraic. In seeking for these latter cases Schwarz was led to introduce a new variable  $s$ , the quotient of two fundamental integrals of  $G=0$ . This variable for certain values of  $\alpha, \beta, \gamma$  satisfies the equation

$$J(s) = 1728x^3(s) + H^3(s) = 0,$$

where

$$f(s) = s(s^3 + 11s^2 - 1),$$

$$H(s) = s^3 - 288s^2 + 494s^3 + 288s^4 + 1.$$

The equation  $J=0$  stands in so intimate relation with the icosahedron that it is called the icosahedral equation. Indeed if we project stereographically the icosahedron, on the  $s$ -plane, the centre being at the origin, the 12 vertices and the middle points of the 20 faces will be precisely the roots of  $f$  and  $H$  respectively.

From this it is easy to conclude that the group of  $J=0$  is formed of the 60 rotations which leave the icosahedron unchanged. Klein has shown that the icosahedral equation whose



roots are very simple known functions of  $F(\alpha, \beta, \gamma, x$  can be put in connection with  $Q=0$ . The equation  $J=0$  may thus be considered as a normal resolvent of the quintic.

A normal resolvent which springs from the elliptic functions is the following: In trigonometry one of the problems is to express  $\sin \frac{x}{n}$  in terms of  $\sin x$ ,  $n$  a prime number. This may be done algebraically, as is readily shown. In the elliptic functions the same problem arises. Here the algebraic relation between  $p \left( \frac{u}{n}, \omega_1, \omega_2 \right)$  and  $p(u, \omega_1, \omega_2)$  is of degree  $n^2-1$ .

The solution of this equation depends upon an equation of degree  $n+1$  called an equation of transformation. For  $n=5$  such an equation is

$$A^2y^4 + 10Ay^3 - 12g_2y + 5 = 0, \tag{15}$$

whose group is the above  $A$ , and whose roots are

$$\left( p \frac{2\omega_1}{5} - p \frac{4\omega_1}{5} \right)^{-1}$$

and

$$\left( p \frac{2\omega_2 + 48r\omega_1}{5} - p \frac{4\omega_2 + 96r\omega_1}{5} \right)^{-1},$$

$$r=0, 1, 2, 3, 4.$$

Here  $4$  is the discriminant  $g_2^3 - 27g_3^2$ . How equations of this type could be set in relation with the quintic was first shown by Hermite in 1858. The equation (15) was used by Kiepert. It forms a very convenient normal resolvent of the quintic.

Having found in the elliptic functions convenient normal resolvents for this quintic, we might hope to employ the equations of transformation of higher orders to solve the general equations of higher degrees. The consideration of their groups, however, shows very easily that this is not possible. To find suitable equations we must pass from the elliptic to the hyperelliptic functions. By their aid the general equation of every degree can be solved.

**Bibliography.**—Bolza, O., 'Theory of Substitution Groups and its Application to Algebra' (*American Journal Math.* V. 13); Cajori, F., 'Theory of Equations' (New York 1904); Hilbert, article in *Crelle's Journal* (V. cx); Hölder, article in *Mathematische Annalen* (V. xxxiv); Jordan (ibid., V. I, 1869) 'Traité des substitutions' (1870); Netto, 'Substitutionentheorie' (tr. by Cole, F. N.); Pierpont, 'Galois Theory of Algebraic Equations' (*Annals of Mathematics*, V. I, II, 1899-1900); Serret, 'Algèbre' (1866); Weber, 'Algebra' (2d ed., 1898-99).

JAMES PIERPONT,

Professor of Mathematics, Yale University.

**EQUATIONS, General Theory of.** The theory of equations finds its origin in efforts to solve the equations which arise in the applications of algebra to problems in pure geometry or in applied mathematics. In the exposition of this theory a rational integral algebraic function of  $x$  arises which may be defined as follows:

$$f(x) = a_n x^n + a_{n-1} x^{n-1} + a_{n-2} x^{n-2} + \dots + a_{n-1} x + a_n.$$

It is assumed here that the exponent  $n$  is a positive integer and that the coefficients  $a_0, a_1, a_2, \dots, a_n$  are algebraic numbers independent of  $x$ . If this polynomial, is put equal to zero,

we have an equation of the  $n$ th degree. Any value of the variable  $x$  which makes the value of the polynomial zero is said to "satisfy the equation"  $f(x)=0$  and is called a "root" of the equation. Thus,  $-1$  is a root of the equation  $x^2 + x + 2 = 0$ , because  $(-1)^2 + (-1) + 2 = 0$ .

**Fundamental Theorems about Roots.**—

That at least one root of the equation  $f(x)=0$  always exists is a fundamental theorem which it is somewhat difficult to establish rigorously. The proofs usually given in elementary texts lack rigor. Among the most satisfactory demonstrations are the four given by C. F. Gauss and the one based on the theory of functions, given by A. L. Cauchy. Granted that every equation of the  $n$ th degree has at least one root, it is easy to show that it has  $n$  roots and no more. An equation of the second degree (a "quadratic equation") has two roots, one of the third degree (a "cubic equation") has three roots, one of the fourth degree (a "quartic" or "biquadratic equation") has four roots, and so on. The proof of this theorem may be outlined as follows: If  $r_1$  is a root of  $f(x)=0$ , then  $f(x)$  is divisible by  $x-r_1$  without a remainder, so that  $f(x) = (x-r_1)f_1(x)$ , where  $f_1(x)$ , the quotient, is of the  $(n-1)$ th degree. If  $r_2$  is a root of  $f_1(x)=0$ , then in the same way  $f_1(x) = (x-r_2)f_2(x)$ , and  $f(x) = (x-r_1)(x-r_2)f_2(x)$ . Proceeding in this manner, the degrees of the successive quotients diminish by unity at every step, until finally a binomial quotient of the first degree of the form  $a_0(x-r_n)$  is obtained. We then have  $f(x) = a_0(x-r_1)(x-r_2) \dots (x-r_n) = 0$ . There are here  $n$  binomial factors and no more, each of which, when equated to zero, yields a root. In special cases some of these roots may be equal to each other. Such roots are called "equal" or "multiple" roots.

There are important relations existing between the roots and the coefficients of an equation. From the equalities

$$\begin{aligned} (x-r_1)(x-r_2) &= x^2 - (r_1+r_2)x + r_1r_2 = 0; \\ (x-r_1)(x-r_2)(x-r_3) &= x^3 - (r_1+r_2+r_3)x^2 \\ &\quad + (r_1r_2+r_1r_3+r_2r_3)x - r_1r_2r_3 = 0; \end{aligned}$$

$$\begin{aligned} (x-r_1)(x-r_2) \dots (x-r_n) &= x^n \\ &- (r_1+r_2+\dots+r_n)x^{n-1} \\ &+ (r_1r_2+r_1r_3+\dots+r_{n-1}r_n)x^{n-2} \\ &- \dots + (-1)^n r_1r_2 \dots r_n = 0. \end{aligned}$$

we see that in the equation  $f(x)=0$ , when  $a_n=1$ , the coefficient  $a_{n-1}$  of the second term is equal to minus the sum of the roots; the coefficient  $a_{n-2}$  of the third term is equal to the sum of the products of the roots, taken two by two; the coefficient  $a_{n-3}$  of the fourth term is equal to minus the sum of the products of the roots, taken three by three; and so on, until finally we arrive at the last coefficient,  $a_0$ , which is equal to  $(-1)^n$  times the product of all the roots. The coefficients of the equation are said to be *symmetric functions* of the roots, that is, functions in which any two roots may be interchanged without altering the value of the function. As an illustration take  $2x^3 + 4x^2 + 6x - 5 = 0$ . To make  $a_n=1$ , divide through by 2. Then the sum of the three roots is  $-2$ , the sum of their products, taken two by two, is 3, the product of all three roots is  $\frac{5}{2}$ .

The roots of an equation may be complex

(i.e., imaginary) quantities. (See ALGEBRA). Thus the equation  $x^2 + x + 1 = 0$  has the two complex roots  $\frac{1}{2}(-1 + i\sqrt{3})$  and  $\frac{1}{2}(-1 - i\sqrt{3})$ , where  $i \equiv \sqrt{-1}$ . If the coefficients of the equation  $f(x) = 0$  are all real, then it can be shown that, if complex roots occur at all, they occur in conjugate pairs; that is, if  $a + ib$  is a root, then  $a - ib$  is likewise a root. From this it follows at once that no cubic or other equation of odd degree and with real coefficients can have all its roots complex. Considerable information on the character of the roots can usually be secured from "Descartes' Rule of Signs," which may be stated as follows: *An equation with real coefficients has as many positive roots as it has variations in sign, or fewer by an even number.* A variation is said to exist whenever two successive terms have opposite signs. Thus there are two variations in  $+ - - +$ . The theorem may be proved from the consideration that every time that a new positive root is introduced into an equation, by multiplying  $f(x)$  by  $(x - r)$ , the number of variations is increased by an odd number. Applying Descartes' Theorem to the equation  $x^6 - x^4 + x^2 + 2x^2 - 5 = 0$ , observe that the sequence of signs is  $+ - + + -$ . There are three variations; hence, the equation has either three positive roots or one. To apply the theorem to negative roots, we first transform the given equation into a new one whose roots are the same as those of the given equation, excepting in sign. This can be done by writing  $-x$  in place of  $x$ . The above sextic then becomes  $x^6 + x^4 + x^2 + 2x^2 - 5 = 0$ . This transformed equation has one variation; hence, by Descartes' Rule (q.v.), it has one positive root, and the given equation has one negative root. As the total number of roots is six and the number of real roots is four or two, it follows that either two or four of the roots are complex. By the same reasoning we can show that  $x^4 - 1 = 0$  has one positive and four complex roots and that  $x^4 + x^2 + 1 = 0$  has all its roots complex. In some cases, as in  $x^4 + x^2 - x^2 + 5 = 0$ , Descartes' Rule gives but little information.

Srenuous efforts have been put forth by mathematicians to discover theorems by which the exact number of real and of complex roots of equations with real coefficients can always be determined. The most noted result of these efforts is the theorem of J. C. F. Sturm, discovered in 1829. Sturm's theorem tells the number of complex roots, and the number of real roots within a given interval, with unflinching certainty; but it labors under the disadvantage of being laborious in its application. Hence it is commonly used only when the simpler methods fail to give the wanted information. We state the theorem for the special case when  $f(x) = 0$  has no equal roots. Let  $f'(x)$  be the first derived function of  $f(x)$ . (See CALCULUS). Then proceed with the process of finding, by division, the highest common factor of  $f(x)$  and  $f'(x)$ , with this modification, that the sign of each remainder be changed before it is used as a divisor. Continue the process until a remainder is reached which does not contain  $x$ , and change the sign of that also. The functions  $f(x)$ ,  $f'(x)$ , together with the several remainders with their signs changed, viz.,  $f_2(x)$ ,  $f_3(x)$ , . . . ,  $f(x)$ , are called "Sturm's functions."

Sturm's theorem is as follows: *If  $f(x) = 0$  has no equal roots, let any two real quantities  $a$  and  $b$  be substituted for  $x$  in Sturm's functions, then the difference between the number of variations of sign in the series when  $a$  is substituted for  $x$  and the number when  $b$  is substituted for  $x$  expresses the number of real roots of  $f(x) = 0$  between  $a$  and  $b$ .* To make this clearer, take  $f(x) = x^3 - x^2 - 10x + 1$ , then  $f'(x) = 3x^2 - 2x - 10$ ,  $f_2(x) = 62x + 1$ ,  $f_3(x) = 38,313$ . For the indicated values of  $x$  the signs of the Sturmian functions are as follows:

$x$	$f(x)$	$f'(x)$	$f_2(x)$	$f_3(x)$
$\infty$	+	+	+	+
4	+	+	+	+
3	-	+	+	+
1	-	-	+	+
0	+	-	+	+
-2	+	+	-	+
-3	-	+	-	+
$-\infty$	-	+	-	+

Since  $x = \infty$  gives no variations and  $x = -\infty$  gives three variations, there are three real roots between  $\infty$  and  $-\infty$ . Hence there are no complex roots. The real roots lie between 3 and 4, 0 and 1, -2 and -3.

**Transformations of Equations.**—The study of the properties of an equation is frequently facilitated by the transformation of the given equation into a new one whose roots (coefficients) bear a given relation to the roots (coefficients) of the original equation. Thus, in applying Descartes' Rule to negative roots we transformed the equation into another whose roots were numerically the same, but differed in sign. If the roots of the new equation are to be  $m$  times those of the one given, we place  $y = mx$  and substitute  $y/m$  for  $x$ . For instance, if the roots of the transformed equation are to be 10 times those in

$$x^3 - x^2 - 2x + 5 = 0, \text{ we get } \frac{y^3}{1000} - \frac{y^2}{100} - \frac{2y}{10} + 5 = 0,$$

or  $y^3 - 10y^2 - 200y + 5000 = 0$ . The result is obtained more easily by the rule: *Multiply the second term by  $m$ , the third by  $m^2$ , and so on.* If the roots of the new equation are to be the reciprocals of the roots of the old we write

$$x = \frac{1}{y}. \text{ A more important transformation is the}$$

one of diminishing the roots by a given number  $h$ . We have here  $y = x - h$ . Substituting  $y + h$  for  $x$  in  $a_0x^n + a_1x^{n-1} + a_2x^{n-2} + \dots + a_n = 0$ , we obtain

$$a_0(y+h)^n + a_1(y+h)^{n-1} + a_2(y+h)^{n-2} + \dots + a_n = 0.$$

Expanding the binomials and collecting like terms, we obtain, let us suppose,

$$A_0y^n + A_1y^{n-1} + A_2y^{n-2} + \dots + A_n = 0.$$

Writing  $x - h$  for  $y$  we get

$$A_0(x-h)^n + A_1(x-h)^{n-1} + \dots + A_{n-1}(x-h) + A_n = 0,$$

which differs from the original equation merely in form. This new form suggests an easy way for carrying out the actual computation. Dividing the left member by  $x - h$ , the remainder obtained is seen to be  $A_n$ , the absolute term. Dividing the quotient thus obtained

by  $x-h$ , the remainder is  $A_{n-1}$ . By repeating this process the remaining coefficients of the required equation are secured. The process, called "synthetic division," is very convenient in this transformation. Suppose we desire to transform  $x^2+8x-x+6=0$  into another in which the second term is wanting. The sum of the roots is  $-8$  hence, to cause  $x^2$  to disappear, we must increase each root by 2 (i.e., diminish by  $-2$ ). Dividing successively by  $x+2$  we obtain the coefficients  $-40, 63, -24, 0, 1$ , and the required equation is  $x^2-24x^2+63x-40=0$ .

The transformations thus far considered are all special cases of the so-called *homographic* or *projective* transformation in which  $y=$

$\frac{ax+b}{cx+d}$ ,  $a, b, c, d$  being constants. Thus, if

$a=d=1$  and  $c=0$ , we have the preceding transformation. The homographic transformation is of interest in geometry, in the study of homographic ranges of points. The most general rational algebraic transformation of the roots of an equation  $f(x)=0$  of the  $n$ th degree can always be reduced to an integral transformation of a degree not higher than the  $(n-1)$ th, and can, therefore, be represented by the relation

$$y = d_1 + dx + dx^2 + \dots + dx^{n-1}.$$

This last is known as the "Tschirnhausen transformation," by which Tschirnhausen in 1683 hoped to be able to reduce the general equation of the  $n$ th degree to the binomial form  $x^n - a = 0$ , which is always solvable. But this transformation to the binomial form can be effected only for general equations that are lower than the fifth degree.

**Solution of Equations.**—This subject resolves itself into two quite distinct parts: (1) The solution of numerical equations (i.e., equations whose coefficients are given numbers) by some method of approximation to the exact value of the roots; (2) the solution of equations, whose coefficients are either given numbers or letters, by operations which will give the accurate values of the roots, expressed in terms of the coefficients,—such expressions to involve no other processes than addition, subtraction, multiplication, division and the extraction of roots. The former is called a solution by *approximation*, the second is called the *algebraic* solution of equations. In the former each root may be found separately, in the latter a general expression is obtained which represents all of the roots indifferently. The former is of importance to the practical computer, the latter is of special interest to the pure mathematician. The solution by approximation can be effected for equations of any degree; the algebraic solution is impossible for general equations of the fifth or of higher degrees. See EQUATIONS, GALOIS' THEORY OF.

**Algebraic Solution of Equations.**—The algebraic solution of the quadratic equation  $ax^2+bx+c=0$  is well known. (See ALGEBRA). The algebraic solution of the cubic, due to Scipio Ferro and Tartaglia, and first published by H. Cardan in 1545, is known as "Cardan's solution." To effect it, first transform the general cubic equation so that the second term shall be wanting. This done, we have  $x^3+ax+b=0$ . Putting  $x=y+z$  we obtain

$$y^3+3yz(y+z)+z^3+a(y+z)+b=0,$$

or  $y^3+z^3+(3yz+a)(y+z)+b=0$ .

We may subject  $y$  and  $z$  to any second condition which is not inconsistent with  $x=y+z$ . It will be convenient to assume  $3yz+a=0$ . Then  $y^3+z^3+b=0$ , or, substituting for  $z$  its

value  $-a/3y$ , we obtain  $y^3+by^3=\frac{a^3}{27}$  and

$$y^3 = -\frac{b}{2} \pm \sqrt{\frac{b^2}{4} + \frac{a^3}{27}},$$

$$z^3 = -y^3 - b = -\frac{b}{2} \mp \sqrt{\frac{b^2}{4} + \frac{a^3}{27}}.$$

Since  $x=y+z$ , we have

$$x = \sqrt[3]{-\frac{b}{2} + \sqrt{\frac{b^2}{4} + \frac{a^3}{27}}} + \sqrt[3]{-\frac{b}{2} - \sqrt{\frac{b^2}{4} + \frac{a^3}{27}}}.$$

Since  $y^3$  and  $z^3$  have each three cube roots, it might seem as if  $y+z$  or  $x$  had altogether nine values. As the cubic has only three roots, this cannot be. Of the nine values, six are excluded by the relation  $3yz+a=0$ , which  $y$  and  $z$  must satisfy. Eliminating  $z$  between  $x=y+z$

and  $3yz+a=0$ , we get  $x=y-\frac{a}{3y}$  where  $y$  has

the three values obtained from the expression for  $y^3$  given above. This last expression for  $x$  does not involve the difficulties of the first expression. If the numerical values of the coefficients  $a$  and  $b$  are given, the numerical values of the roots may be obtained by substituting the values of  $a$  and  $b$  in the above expression for  $x$ . In any case, this mode of computing  $x$  is more laborious than Horner's method of approximation (explained below), but when all three roots of the cubic are real and distinct, an unexpected difficulty is encountered.

In this case  $\frac{b^2}{4} + \frac{a^3}{27}$  represents a negative num-

ber. As the square root of a negative number is a complex (imaginary) number, we are required to find the cube root of a complex number. But there exists no convenient arithmetical process for doing this. Nor is there any way of avoiding the complex radicals and of expressing the values of the real roots by real radicals. This is the famous "irreducible case" in the solution of the cubic. Its interest is purely theoretical. The practical computer experiences no difficulty, for he can always find the values of  $x$  by the methods of approximation.

Since Cardan's time a great many different algebraic solutions of the cubic and also of the quartic have been given. They are brought together for convenient reference in L. Mathiessen's 'Grundzüge der Antiken und Modernen Algebra,' Leipzig 1878. We proceed to give Euler's algebraic solution of the general quartic. By transforming it, bring it to the form  $x^4+ax^2+bx+c=0$ . Assume the general expression for a root to be  $x=\sqrt{u}+\sqrt{v}+\sqrt{w}$ . Squaring,

$$x^2 - u - v - w = 2\sqrt{u}\sqrt{v} + 2\sqrt{u}\sqrt{w} + 2\sqrt{v}\sqrt{w}.$$

Squaring again and simplifying,

$$x^4 - 2x^2(u+v+w) - 8x\sqrt{u}\sqrt{v}\sqrt{w}$$

$$+ (u+v+w)^2 - 4(uv+uw+vw) = 0.$$

Equating coefficients of this and the given quartic we have

$$a = -2(u+v+w), \quad b = -8\sqrt{u}\sqrt{v}\sqrt{w}.$$

$$c = (u+v+w)^2 - 4(uv+uw+vw).$$

But  $-(u+v+w)$ ,  $(uv+uw+vw)$ ,  $-uvw$  are the coefficients of a cubic whose roots are  $u, v, w$ . This cubic, called "Euler's cubic," is

$$y^3 + \frac{a}{2}y^2 + \frac{a^2-4c}{16}y - \frac{b^3}{64} = 0.$$

Solving it, we have the values of  $u, v$  and  $w$ , and, therefore, the values of  $x$ . Of the eight apparent values of  $x$ , four are excluded by the relation  $b = -8\sqrt{u}\sqrt{v}\sqrt{w}$ . To solve the quartic by the present method we must, therefore, first solve "Euler's cubic," called the *resolvent*. When this resolvent has a rational root, then its other two roots can be expressed in terms of square roots and the quartic can be solved algebraically without the extraction of cube roots. All methods of solving algebraically the general quartic depend upon the solution of some resolvent cubic.

Binomial equations of the form  $x^n - 1 = 0$ , or more generally, of the form  $x^n - a = 0$ , are known as cyclotomic equations, and can always be solved algebraically. They possess also many interesting properties. We shall give a *trigonometric* solution and mention a few of these properties. Let  $x^n = a = r[\cos(2k\pi + \theta) + i \sin(2k\pi + \theta)]$ , where  $a$  may be a complex quantity, where  $k$  may be any integer, and where  $r$  and  $\theta$  are known from the value of  $a$ . (See TRIGONOMETRY). By De Moivre's theorem we obtain

$$x = \sqrt[n]{r} \left\{ \cos \frac{2k\pi + \theta}{n} + i \sin \frac{2k\pi + \theta}{n} \right\}.$$

By assigning to  $k$  any  $n$  consecutive integral values we obtain  $n$  distinct values for  $x$  and no more than  $n$ , since the  $n$  values recur in periods. These values are the roots required.

Among the properties of  $x^n - 1 = 0$  are the following: It has no multiple roots; if  $r$  is a root, then any positive integral power of  $r$  is a root; if  $m$  and  $n$  are relatively prime, then  $x^m - 1 = 0$  and  $x^n - 1 = 0$  have no roots in common, except 1; if  $h$  is the highest common factor of  $m$  and  $n$ , then the roots of  $x^h - 1 = 0$  are common to  $x^m - 1 = 0$  and  $x^n - 1 = 0$ ; if  $r$  is a complex root of  $x^n - 1 = 0$ ,  $n$  being a prime number, then  $1, r, r^2, \dots, r^{n-1}$  are the roots; the roots of  $x^m - 1 = 0$  and  $x^n - 1 = 0$  satisfy the equation  $x^{mn} - 1 = 0$ ;  $x^n - 1 = 0$  has always *primitive* roots, i.e., roots which are not also roots of unity of a lower degree than  $n$ . For the proofs consult Burnside and Panton, 'Theory of Equations,' Vol. I. The theory of roots of unity is closely allied with the problem of inscribing regular polygons in a circle, or the theory of the "division of the circle." Consult P. Bachmann, 'Kreistheilung,' Leipzig 1872.

**Solution by Approximation.**—Of the various methods which have been given for the solution of numerical equations, the most satisfactory, all things considered, is the one known as "Horner's method." It is commonly used for finding *incommensurable* roots (i.e., such as involve an interminable decimal which is not a repeating decimal), but it may be used also for finding *commensurable* roots (i.e., such as are integers or rational fractions). It is desirable here to begin with the theorem that a *rational fraction cannot be a root of an equation of the  $n$ th degree with integral coefficients, the coefficient of  $x^n$  being unity*. To prove this, let, if possible,

$\frac{h}{k}$  be a root of  $f(x) = 0$ , where  $h$  and  $k$  are in-

tegers and  $\frac{h}{k}$  a fraction reduced to its lowest

terms, and where  $a_0 = 1$ . Substitute  $\frac{h}{k}$  for  $x$ , then multiply both members of the equation by

$k^n - 1$ , and we obtain, after transposing,  $\frac{h^n}{k} =$

$-a_1 h^{n-1} - a_2 h^{n-2} k - \dots - a_{n-1} k^{n-1}$ . This equation is impossible, since a fraction in its lowest terms cannot equal an integer. Hence  $\frac{h}{k}$

cannot be a root. This being the case, it follows that all commensurable roots are exact divisors of  $a_n$ , for  $a_n$  is numerically the product of all the roots. We know that if  $(fx)$  is divisible by  $x - r$ , without a remainder,  $r$  is a root. Hence we are enabled to find all commensurable roots of numerical equations of the type now under consideration by testing in succession each factor of  $a_n$ . For instance, in the equation  $x^3 + 8x^2 + 13x + 2 = 0$  the factors of  $a_n$  are  $\pm 1$  and  $\pm 2$ . Taking the factor  $-2$ , we find that  $f(x)$  is exactly divisible by  $x + 2$ . The test for each of the three other factors yields a remainder. Hence  $-2$  is the only commensurable root.

Before we can apply Horner's method we must know the first significant figure of the root to be found. In other words, we must "locate" the root. This can always be done by Sturm's theorem, but usually the following theorem is more convenient. *If two real numbers  $a$  and  $b$ , when substituted for  $x$  in  $f(x)$ , give to  $f(x)$  contrary signs, an odd number of roots of the equation  $f(x) = 0$  lies between  $a$  and  $b$ .* Thus, to locate the roots of  $x^3 - 3x^2 - 46x - 71 = 0$ , substitute for  $x$ , in succession, the values  $-6, -5, -4, -3, -2, -1, 0, 1, 2, 3, 4, 5, 6, 7, 8, 9, 10$ . It is found that  $f(-5)$  and  $f(-4)$ ,  $f(-2)$  and  $f(-1)$ ,  $f(8)$  and  $f(9)$  are pairs of values of  $f(x)$  having opposite signs. As there are three roots in all, we conclude that there is just one root between each of the pairs of values  $-5$  and  $-4, -2$  and  $-1, 8$  and  $9$ . To reduce the number of trials in more difficult examples, there are theorems on the upper and lower limits of roots which may be applied.

Horner's method consists of successive transformations of an equation. Each transformation diminishes the root by a certain amount. If the required root is 1.955, then the root is diminished successively by 1, .9, .05, .005. Synthetic division is employed. Suppose we desire to find, to three decimals, the root between  $-1$  and  $-2$  in the above example. It is convenient first to transform the equation so that the root becomes positive. We get  $x^3 + 3x^2 - 46x + 71 = 0$ . The first significant figure in the root is 1. To diminish the roots by 1 we perform by synthetic division the following operation:

$$\begin{array}{r} 1 + 3 - 46 + 71 \mid 1 \\ \underline{1} \\ 4 - 42 + 29 \\ \underline{4} \\ 1 + 5 \\ \underline{5} \\ -37 \\ \underline{-37} \\ 1 \\ \underline{1} \\ 6 \end{array}$$

The transformed equation, whose root under

consideration now lies between 0 and 1, is  $x^3 + 6x^2 - 37x + 29 = 0$ . This root being less than unity,  $x^2$  and  $x^3$  are less than  $x$ . Neglecting  $x^2$  and  $6x^2$ , we obtain an approximate value for  $x$  from  $-37x + 29 = 0$ , viz.,  $x = .7$ . As in the process of ordinary long division or in the extraction of roots, so here the digit obtained by the first approximate division may be too large or too small and may need correction. An error of this sort will reveal itself later in the attempt to find the third digit of the root. Such correction is needed here. Actually  $x = .9$ . Diminish the roots of the last transformed cubic by .9, then find the third digit by the process just indicated for finding the second digit, then diminish the roots again, and so on. The entire operation is as follows:

1 + 3	- 46	+ 71	1.955
1	4	- 42	
4	- 42	+ 29	
1	5	- 27.711	
5	- 37	+ 1.289	
1	0.21	- 1.166625	
6	- 30.79	+ .122375	
.9	7.02		
6.9	- 23.77		
.9	.4375		
7.8	- 23.3325		
.9	.4433		
8.7	- 22.8925		
.05			
8.75			
.05			
8.80			
8.05			
8.85			

The broken lines indicate the conclusion of the successive transformations. For advanced reading on the solution of numerical equations consult McClintock, E., in *Am. Jour. of Maths.*, Vol. XVII, pp. 89-110; Carvallo, M. E., 'Résolution numérique complète d. Equations algébriques ou transcendantes' (Paris 1896); A. Xavier, 'Approximations numériques' (Paris 1909).

**Multiple Roots.**—Suppose that in  $f(x) = 0$  there are  $m$  multiple roots; that is,  $m$  roots are equal to each other. Then  $f(x) = (x - r)^m \phi(x)$ , and the first derivative is  $f'(x) = (x - r)^{m-1} \phi(x) + m(x - r)^{m-2} \phi'(x)$ . The fact that  $f(x)$  and  $f'(x)$  have the factor  $(x - r)^{m-1}$  in common suggests the following rule for the discovery of multiple roots: Find the highest common factor of  $f(x)$  and  $f'(x)$ . If that factor is  $(x - r)^s$ , then  $r$  occurs as a root  $s + 1$  times. If the highest common factor is  $(x - r)^s(x - r_1)^t$ , then  $r$  occurs as a root  $s + 1$  times and  $r_1$  occurs  $t + 1$  times. If  $f(x) \equiv 8x^3 - 20x^2 + 6x + 9$ , then  $f'(x) \equiv 24x^2 - 40x + 6$ , and the H.C.F. is  $2x - 3$ . Hence  $\frac{3}{2}$  is a double root.

**Elimination.**—Take the equations,

$$f(x) \equiv x^2 + b_1x + b_2 = 0,$$

$$F(x) \equiv x^2 + a_1x + a_2 = 0,$$

and let  $r_1$  and  $r_2$  be the roots of the second equation. The necessary and sufficient conditions that the two equations shall have a root in common is that  $f(r_1)$  or  $f(r_2)$  shall vanish;

that is, that the product  $f(r_1) \cdot f(r_2)$  shall be zero. Multiply together

$$f(r_1) \equiv r_1^2 + a_1r_1 + a_2,$$

$$f(r_2) \equiv r_2^2 + a_1r_2 + a_2,$$

we get

$$r_1r_2^2 + a_1(r_1r_2^2 + r_1^2r_2) + a_2(r_1^2 + r_2^2) + a_1^2r_1r_2 + a_1a_2(r_1 + r_2) + a_2^2.$$

Expressing the symmetric functions of  $r_1$  and  $r_2$  in terms of the coefficients of the second of the given equations, we get  $r_1^2r_2^2 = b_2^2$ ,  $r_1r_2^2 + r_1^2r_2 = -b_1b_2$ ,  $r_1^2 + r_2^2 = b_1^2 - 2b_2$ ,  $r_1r_2 = b_1$ ,  $r_1 + r_2 = -b_1$ . Substituting these values, we have  $b_2^2 - a_1b_1b_2 + a_2b_1^2 - 2a_1b_2 + a_1^2b_2 - a_1a_2b_1 + a_2^2$ .

This expression, involving the coefficients of the two given equations, is called the *eliminant* or *resultant*. Its vanishing is the condition that these equations have a root in common. More generally, if from  $n$  equations with  $n - 1$  variables we eliminate the variables and obtain an equation  $R = 0$ , involving only the coefficients, the expression  $R$  is called the *eliminant* or *resultant* of the given equations.

In the above example the elimination was performed with the aid of symmetric functions. Of other methods of elimination the best known are those of Euler, Bezout and Sylvester. We outline the last, known as Sylvester's Dialytic Method. To eliminate  $x$  between

$$f(x) \equiv a_0x^n + a_1x^{n-1} + \dots + a_n = 0,$$

$$F(x) \equiv b_0x^m + b_1x^{m-1} + \dots + b_n = 0,$$

multiply the first successively by  $x^0, x^1, x^2, \dots, x^{m-1}$ , and the second successively by  $x^0, x^1, x^2, \dots, x^{n-1}$ , and we obtain  $m + n$  equations. The highest power of  $x$  is  $m + n - 1$ . If  $f(x) = 0$  and  $F(x) = 0$  have a common root, it will satisfy all the  $m + n$  equations. If the different powers of  $x$ , viz.,  $x, x^2, \dots, x^{m+n-1}$ , be taken as  $m + n - 1$  unknown quantities, satisfying  $m + n$  linear equations, a relation will exist between the coefficients. This condition of consistency is the vanishing of the resultant. This resultant Sylvester expressed neatly in the form of a determinant. See DETERMINANTS.

**Discriminants.**—It has been shown that a multiple root of  $f(x) = 0$  is also a root of  $f'(x) = 0$ . But the condition that these two equations have a common root is expressed by the vanishing of the resultant.

The resultant of  $f(x) = 0$  and  $f'(x) = 0$  is called the *discriminant* of  $f(x) = 0$ . It may be otherwise defined as the simplest function of the coefficients, or of the roots, whose vanishing signifies that the equation has equal roots.

To the references already given we add the following: 'Encyklopädie der mathematischen Wissenschaften,' Band I; Cajori, Florian, 'Introduction to the Modern Theory of Equations' (New York 1904); Netto, E., 'Vorlesungen über Algebra' (Leipzig, Vol. I, 1896, Vol. II, 1900); Serret, J. A., 'Cours d'Algèbre Supérieure' (Paris, 2 vols.); Todhunter, 'Theory of Equations' (London 1880); Weber, H., 'Lehrbuch der Algebra' (Braunschweig, Vol. I, 1898, Vol. II, 1896); 'Encyklopädie der elem. Algebra und Analysis' (Leipzig 1903).

FLORIAN CAJORI,

Professor of History of Mathematics, University of California.

**EQUATIONS, Integral.** See INTEGRAL EQUATIONS.

**EQUATOR**, an imaginary great circle of the celestial vault or on the surface of the earth. As used in astronomy the term signifies a great circle of the celestial vault at right angles to its axis, and dividing it into a northern and a southern hemisphere. It is constituted by the plane of the earth's equator, produced in every direction till it reaches the imaginary celestial sphere. The sun is twice a year in the celestial equator—namely, at the equinoxes, whence the equator is also known as the equinoctial line, or simply the equinoctial (see **EQUINOX**). The point in the equator which touches the meridian is raised above the true horizon by an arc which is the complement of the latitude. The sun and planets all have equators. They rotate around their several axes and the plane at right angles in each case is the equator of the heavenly body. In geography, the equator is a great circle on the surface of the earth equidistant from its poles, and dividing it into two hemispheres. Its latitude is zero; it is therefore marked on maps as 0. Other parallels of latitude are counted from it, augmenting in their numerical designation as their distance from it north or south increases, the poles being 90 degrees. The plane of the terrestrial equator is a plane perpendicular to the earth's axis and passing through its centre. The magnetic equator is a somewhat irregular line, nearly but not quite a great circle of the earth, in which there is no dip of the magnetic needle. It is hence called also the acimic line. It is not far from the geographical equator, but its situation slowly alters year by year, there being a slow oscillation of the magnetic poles, while the geographical equator and poles are almost fixed.

**EQUATORIAL** ("of the equator"), a geographical and astronomical term. In astronomy it is usually applied to a telescope so mounted that the right ascension and declination of the point in the heavens at which it is directed can be read off from two scales. Clockwork is sometimes attached to the instrument to give the motion in right ascension, and thereby keep the object constantly in the field of the instrument. See **ASTRONOMY**; **TELESCOPE**.

**EQUATORIAL COUDÉ** ("Elbow Equatorial"), a form of equatorial telescope invented by Loewy, of the Paris Observatory. The observer can remain stationary in a comfortable position, with a desk table built around the eyepiece end, and can have all this part enclosed from the cold, and warmed if desired, at the same time commanding the whole heavens without rising from his chair. See **ASTRONOMY**; **TELESCOPE**.

**EQUATORIAL CURRENT**. See **OCEAN CURRENTS**.

**EQUERRY**, ěk'wě rĭ, an official of the royal household of Great Britain in the department of the master of the horse. There are the crown equerry, equerries in ordinary and extra equerries, 7 of the former and 15 of the latter, all army or navy officers, one or more of whom is attached to the suite of each member of the royal family.

**EQUESTRIAN ORDER**, or **EQUITES**, the order of knights in ancient Rome (Latin *ordo equester*). The equites or knights originally formed the cavalry of the army. They

are said by Livy to have been instituted by Romulus, who selected 300 of them from the three principal tribes, naming them "celeres." Servius Tullius increased the number to 18 centuries, and later there were 1,800 equites. Soon after the first Punic War the equites became a distinct order in the state and the juries and the farmers of the revenue were selected from their ranks. They held their position in virtue of a certain property qualification, 400,000 sesterterii, about \$17,000, and toward the end of the republic they possessed much influence in the state. The body of equites was of mixed patrician and plebeian rank, a fact that helped to increase their political power. They had particular seats assigned to them in the circus and theatre, and the insignia of their rank, in addition to a horse, were a gold ring and a tunic with two narrow purple stripes. At first the equites received two horses from the state, one for the knight and the other for his servant, and the wherewithal to maintain them. But, at a later date when the order had become a desirable one to belong to (shortly after 400 B.C.) wealthy citizens began to enter it; and these furnished their own horses and maintained them at their own expense. This was because from the equites the higher officers of the army were selected, only after the candidate for office had passed successively through the equestrian cursus honorum, a definite series of offices, supposed to fit him for the performance of the duties of the higher post in the army or of that of certain magistrate offices to which the equites might be appointed. Their privileges were curtailed by Sulla and under the later emperors the order disappeared from the stage of political life.

**Bibliography**.—Bouché-Leclercq, A., 'Manuel des antiquités romaines'; Bury, J. B., 'The Student's Roman Empire' (1893); Cagnat, R., 'Equites' (in 'Dictionnaire des Antiquités' by Daremberg and Saglis); Friedländer, A. H., 'Sittengeschichte Roms' (1901); Greenidge, A. J. H., 'History of Rome' (1904); Herzog, E., 'Geschichte und System der Römischen Staatsverfassung' (Leipzig 1891); Madvig, J. N., 'Die Verfassung des römischen Staates'; Mommsen, T., 'Hermes' (1881); Taylor, T. M., 'Political and Constitutional History of Rome' (1899); Wilkens, A. S., 'Equites' (in Smith's 'Dictionary of Roman Antiquities' (3d ed. 1891)).

**EQUIDÆ**, ěk'wĭ-dē, the horse family, the most highly specialized of the perissodactyl ungulates, characterized by the fact that only one toe (the third) in each foot is now functional, traces ("the splint bones") remaining of the two other toes (the second and fourth) in the "splint bones" hidden beneath the flesh on each side of the shank of the foot. (For the relationships of this family to the titanotheres, tapirs and rhinoceroses, see **UNGULATA**; and for the evolution of the characteristic foot-structure see **HORSE, EVOLUTION OF**). The family contains but a single extant genus (*Equus*), structural distinctions not being of sufficient importance to separate generically the modern horses from several extinct species, or from the asses or zebras, or these from each other. Apart from the dependence upon a single toe, the family is characterized by the facts that the orbit is completely surrounded by bone; the in-

cisor teeth are chisel-shaped; the canines or "tusches" are rudimentary (when present), and the premolars (except the first or "wolf tooth") resemble the hypselodont molars. Externally the members of this family are robust, with comparatively slender limbs, the feet "booted" in a single horny hoof, encasing the terminal phalanx; the body thickly clothed with short close hair, which, however, becomes longer, and in some species profuse, forming a mane, on the nape and tail. The colors are apt to be disposed in dark stripes on a yellow or brownish ground, most strikingly in the zebras, but traceable in most others. There are never any horns, and speed is depended on to escape from enemies which cannot be beaten off by kicking with the hind feet, while struggles between rival males for the leadership of the bands of mares are carried on mainly by biting and striking with the fore feet. The fore-limbs, or both pairs, have a callous pad upon the inside, "which," says Beddard, "is possibly to be looked upon as an aborted gland, probably originally of use as secreting some odorous substance calculated to enable strayed members of the herd to regain their companions." The whole structure of the *equidae* has been developed in adaptation to a life upon open dry plains, where ability to travel with rapidity and to live upon grass and herbage has been perfected to a high degree. The stomach has no such complicated arrangement for the assimilation of this comparatively innutritious diet as has been acquired by the ruminants (q.v.). The alimentary canal is of great length (about eight times the length of the body); and the stomach, simple in form, is divided into a cardiac and a pyloric part, sharply distinguished by the dense epithelial lining of the former. The cæcum is twice as large as the stomach and there is no gall-bladder. The teats are two in number and situated in the groin. One or two foals are produced at a birth after a gestation of about 11 months. All the species are gregarious and polygamous and like most such animals are readily tamable, though the zebra has proved somewhat intractable and useless to mankind.

The family in the course of its history has occupied all the larger land-areas of the globe except Australia; but although its ancestors abounded in both Americas in the past, and modern horses run wild have multiplied and flourished exceedingly upon their grassy plains, no living species is native to the New World. In the Old World the horse or horses and several of the asses were Asiatic and European; a second species of ass and the various zebras were wholly African. See ASS; HORSE; QUAGGA; ZEBRA.

**EQUILIBRIUM**, a state of balance as to the forces acting upon any body. The condition is generally considered in respect to the action of gravity, and especially as to the centre of gravity of the body under observation. In accordance with that law of physics that the centre of gravity tends always to occupy the lowest possible position—that is, the position in which it is nearest to the centre of the earth—equilibrium appears in three forms: (1) stable equilibrium, when the centre of gravity is below the point of support; (2) unstable equilibrium, when the centre of gravity is above the point of support; (3) neutral equilibrium,

when the centre of gravity and the point of support coincide. An illustration may be found in a wheel supported free of the ground on its axle. If the wheel is of uniform build in all of its parts it will be in neutral equilibrium, remaining at rest in any position to which it may be revolved on the axle. If, however, a weight be attached to the rim of the wheel at its lowest point, when the wheel is moved so as to raise the weight ever so little the wheel will swing back until the weight is again at the lowest point, in which position it is in stable equilibrium. If the wheel is then revolved so that the weight is directly above the axle, and carefully balanced in that position, the wheel will be in unstable equilibrium, for when disturbed it will immediately revolve so as to bring the weight to the lowest point again, and come to rest in stable equilibrium. See APPLIED MECHANICS; MECHANICS.

In *physiology*, the ability to maintain the body by proper muscular force under nervous control, so that it can perform co-ordinated movements or resist the force of gravity. By equilibrium is here meant the control of the body in the upright position, apart from the localized processes of co-ordination. Loss of equilibrium shows itself particularly in walking and running. Here the centre of gravity of the body is constantly changing and the ability of the individual to hold himself erect depends upon a number of features. The eye, the tactile sense of the feet, the joint-senses, the muscular sense that weighs the various muscular movements and the higher cerebral centres are all involved, and loss of equilibrium or inco-ordination may result from disease or injury to any of these functions. Loss of eyesight does not necessarily involve any loss of equilibrium, but loss of tactile sense of the feet, such as is seen in locomotor ataxia or in people who have had their feet frozen, almost invariably produces a loss of equilibrium. In the same disease (locomotor ataxia) and in forms of neuritis the loss of muscular sense and joint-sense produces similar phenomena. For the higher cerebral centres of control there is good reason to believe that the semi-circular canals in the internal ear constitute a special sense-organ for the determination of the direction of the movements of the head which are so essential in the preservation of general equilibrium. Diseases of the semi-circular canals are frequently accompanied with dizziness and vertigo. It has been suggested that the sacculus and utriculus of the internal ear act to maintain equilibrium while at rest. It also seems probable that certain areas in the cerebellum are closely associated with the equilibrium. See CEREBELLUM; INCOORDINATION; LOCOMOTOR ATAXIA.

**EQUILIBRIUM, Chemical.** In mechanics a system is said to be in equilibrium when the forces that act upon it are precisely balanced, so that their resultant is everywhere zero. A system or mass is similarly said to be in chemical equilibrium when its state is such that there is no tendency toward a sensible chemical change in any of its parts. As set forth by Berthollet, chemical equilibrium is not a condition of rest, but one in which the velocity of reaction in one direction is equal to the velocity in the opposite direction. The absence of chemical action may be absolute, or merely apparent.

In other words, there may be no chemical changes going on at all, or there may be opposite changes going on simultaneously in such a way that no resultant modification can be observed in any part of the system, however small the part selected for observation may be. In the latter case the existence of the simultaneous and opposite reactions can only be indirectly inferred from a study of the system when it is not in equilibrium.

According to the theory of chemical affinity that was held before the importance of mass-action was understood, two substances either would combine or would not, according as their "affinities" were more or less completely satisfied in the combined state, or in the uncombined state. That this view is entirely inadequate to explain the facts of chemistry is made evident by the following simple example: When steam is passed over red-hot iron filings it is decomposed into oxygen and hydrogen, the iron absorbing the oxygen with the formation of oxide of iron, while the hydrogen escapes in the free state; but if hydrogen is passed over red-hot oxide of iron the oxide is reduced to the metallic state, its oxygen combining with the hydrogen to produce steam, which passes on in the hydrogen current. This apparent contradiction may be best explained by assuming that when a mixture of steam and hydrogen is in contact with a red-hot mixture of iron oxide and metallic iron, both of the foregoing reactions take place simultaneously. If the metallic iron and the steam are present in excessive amounts, the resultant action will be, on the whole, the oxidation of the iron and the decomposition of the steam; while if the iron oxide and the hydrogen are present in excess, the resultant action will be the reduction of the oxide to the metallic state and the simultaneous formation of steam. It is therefore apparent that in some reactions, at any rate, the relative masses in which the various constituents are present must be considered with much care before any prediction of the chemical deportment of the mixture can be made. Attention was first directed to this fact by Claude Louis Berthollet (*'Essai de statique chimique'* 1803). In the example cited above, if the iron, iron oxide, hydrogen and steam were left in contact in a closed vessel, a state of apparent equilibrium would be finally attained in which the formation and decomposition of the steam would occur with equal rapidity, so that no visible change would take place thereafter. When this state of "chemical equilibrium" is attained the abstraction of hydrogen or of iron oxide, or the addition of steam or of metallic iron, will destroy the equilibrium, and more iron will be oxidized, until a new state of equilibrium is established. Similarly, the abstraction of steam or of metallic iron or the addition of hydrogen or of iron oxide when the system is in equilibrium will be followed by the reduction of a portion of the iron oxide and the establishment of a new state of equilibrium. According to Berthollet, all reactions are fundamentally of this kind. When sodium chloride is added to a solution of silver nitrate we know that the silver is all thrown down in the form of an insoluble chloride. In this case, Berthollet would consider that the sodium chloride, sodium nitrate, silver chloride and silver nitrate tend toward a state of chemical equilibrium; but that since the

silver chloride is continually removed from the solution by reason of its insolubility, it is impossible for the state of equilibrium ever to be attained, just as it would be impossible for such a state to be attained in our previous illustration, if one of the constituents (say the iron oxide) were removed, or rendered inactive in any way, as fast as it were formed.

The ideas of Berthollet have been found to be sound in their essentials, and they have served as the foundation for the modern theory of chemical action, though their full development cannot be explained without the use of the differential calculus. The basis of the theory of mass-action, so far as solutions are concerned at all events, appears to be substantially as follows: Two substances in solution cannot combine with each other, except when a molecule, or ion (see SOLUTIONS) of the one, in its wandering through the solution, chances to encounter a molecule or ion of the other. Now while we do not know the actual number of encounters that take place in a given time between molecules of different kinds, we do know that in a homogeneous solution the chance that any one given molecule of the first kind will encounter some molecule of the second kind within (say) the next second, is strictly proportional to the number of molecules of the second kind that are present in the solution; and conversely, the chance that any given molecule of the second kind will encounter some molecule of the first kind within the next second is strictly proportional to the number of molecules of the first kind that are present. Since the number of molecules of each kind that are present in an actual solution is practically infinite, this amounts to saying that the actual number of encounters between molecules of different kinds, in one second, is proportional to the product of the number of molecules of the first and second kinds that are present. As an illustration of the usefulness of this principle, we may consider the equilibrium of a mixture of acetic acid and ethyl alcohol. Some of the acid combines with some of the alcohol to form water and ethyl-acetic ester (see ESTERS), but the reaction is never complete, since a state of equilibrium is attained after a time, in which the inverse combination takes place just as fast as the direct one. The molecular weight of acetic acid ( $\text{CH}_3\text{COO.H}$ ) is 60, that of ethyl alcohol ( $\text{C}_2\text{H}_5\text{OH}$ ) is 46, that of ethyl-acetic ester or ethyl acetate ( $\text{CH}_3\text{COO.C}_2\text{H}_5$ ) is 88, and that of water ( $\text{H}_2\text{O}$ ) is 18. A mass of any substance which contains as many grams as there are units in the molecular weight of the substance is known as a "gram-molecule" of the substance. This name is rather unhappily chosen, but the idea itself is a useful one, and is commonly employed in modern writings upon theoretical chemistry. Let us suppose that one gram-molecule of acetic acid (60 grams) is originally mixed with M gram-molecules of ethyl alcohol (46M grams), and with N gram-molecules (18M grams) of water, and let us inquire what the composition of the mixture will be when the state of final chemical equilibrium has been attained. The advantage of taking the gram-molecule as a unit of mass is, that when this unit is used the number of grams of acetic acid, alcohol and water that are originally present will be proportional to 1, M and N, and we may speak of M and N and



write them in our equations precisely as though they were really the number of actual molecules present. The acetic acid and alcohol act upon each other as indicated by the equation  $\text{CH}_3\text{COO.H} + \text{C}_2\text{H}_5\text{OH} = \text{CH}_3\text{COO.C}_2\text{H}_5 + \text{H}_2\text{O}$ . Now let us assume that when the state of equilibrium has been attained,  $X$  gram-molecules of the alcohol have been decomposed. This implies that  $X$  gram-molecules of the acetic acid have also been decomposed, and that  $X$  gram-molecules, each of water and of ethyl acetate have been formed. The total numbers of gram-molecules of the various substances that are present when the final state of equilibrium is attained are therefore as follows: Acetic acid,  $1-X$ ; alcohol,  $M-X$ ; water,  $X$ ; ethyl acetate,  $N+X$ . The number of molecular collisions per second, in which a molecule of acetic acid encounters a molecule of alcohol, is therefore (in the final state) proportional to  $(1-X)(M-X)$ ; and since the chemical action is itself proportional to the number of such collisions, we may assume that the number of gram-molecules of ethyl acetate formed per second, in the state of equilibrium, is  $A(1-X)(M-X)$ , where  $A$  is a constant whose value we do not know. The same line of reasoning shows that the number of gram-molecules of ethyl acetate that are lost from the solution in the same time, through combining with water to reproduce acetic acid and alcohol, is  $B(N+X)X$ , where  $B$  is another constant, whose value is also unknown. Since the existence of equilibrium requires that the quantity of ethyl acetate present shall be constant, we have  $A(1-X)(M-X) = B(N+X)X$ . Now it is known by experiment that when the original mixture is free from water, and contains chemically equivalent amounts of acetic acid and alcohol, so that  $M=1$  and  $N=0$ , the state of final equilibrium is attained when  $X=2/3$ . If these values of  $M$  and  $X$  are substituted in the foregoing equation, we find that  $A$  and  $B$  are connected by the necessary relation  $A=4B$ . If we replace  $A$  by  $4B$  and then divide through by  $B$ , the foregoing equation reduces to  $4(1-X)(M-X) = (N+X)X$ , or  $3X^2 - (4+4M+N)X + 4M = 0$ , a quadratic equation from which the value of  $X$  (that is, the number of gram-molecules of acetic acid decomposed) may be inferred, in the final state of equilibrium, for any desired initial mixture of acetic acid, alcohol and water. This example has been given at some length, both because it illustrates clearly the principles of chemical equilibrium and the law of mass-action, and because reactions of this very kind, in which esters are formed by the direct action of an acid upon an alcohol, have a special historic interest, since their study has contributed in no small measure toward placing the modern theory of chemical equilibrium upon a firm foundation.

When it is desired to determine the state of a chemical system after the lapse of a definite interval from an initial instant for which its state is given, we must form a differential equation in which the condition is expressed that the chemical change, per unit of time, is proportional (as above) to the product of the number of gram-molecules of the reacting substances that are present at the instant considered; and having formed this equation and integrated it, we obtain an expression in which the composition of the system is expressed as a

function of the time. When several substances that may react upon one another are present, the differential equation is more complicated in form, as might be expected; but for details of this sort reference must be made to works on theoretical chemistry. When the system contains several acids and one or more bases, the distribution of the bases among the various acids may be investigated in accordance with similar principles, and by comparing the numerical results that are thus obtained with the facts of observation, estimates of the true relative "affinities" of the acids may be had.

When, as is often the case, the course of a reaction depends upon the temperature, the principles of mass-action apply as before, but regard must also be had for the laws of thermodynamics (q.v.), which usually impose certain limitations upon the equations. The full theory of chemical changes in which thermodynamical considerations play an important part was given by J. Willard Gibbs, in a paper of great power and originality, entitled 'On the Equilibrium of Heterogeneous Substances,' published in the 'Transactions of the Connecticut Academy of Arts and Sciences' for 1875. Gibbs' basic phase law, or "phase rule" as it is commonly called, is as follows:

$\mu$  different bodies (chemical substances, either simple or compound) can form  $\mu+2$  phases, and these can co-exist at one single point only; that is, at a definite temperature and pressure.

The great importance of a full understanding of the laws of chemical equilibrium rests in the fact that by far the larger part of all chemical processes, both in nature and in the industrial arts, result not in complete reactions, but in a condition of chemical equilibrium, with measurable quantities present of every possible compound.

**Bibliography.**—Arrhenius, S. C., 'Theories of Chemistry' (London 1907); Bigelow, S. L., 'Theoretical and Physical Chemistry' (New York 1912); Comey, A. M., 'Dictionary of Chemical Solubilities' (London 1896); Findlay, A., 'The Phase Rule' (London 1911); Hoff, J. H. van't, 'Lectures on Theoretical and Physical Chemistry' (London 1899); Nernst, W., 'Theoretical Chemistry' (London 1895).

**EQUIMULTIPLE.** See MULTIPLE SERIES.

**EQUINE ANTELOPE.** See BLAUBOK.

**EQUINOCTIAL**, in astronomy, synonymous with equator. When the sun is on the equator there is equal length of day and night over all the earth: hence the name equinoctial. See EQUATOR; EQUINOX.

**EQUINOCTIAL GALE**, a gale popularly supposed to occur at the time of the spring or autumn equinox. See EQUINOX.

**EQUINOCTIAL POINTS** are the two points wherein the equator and ecliptic intersect each other; the one, being the first point of Aries, is called the vernal point; and the other, in the first point of Libra, the autumnal point. See ECLIPTIC; EQUINOX; EQUINOXES, PRECESSION OF THE.

**EQUINOX**, in astronomy, is that time of the year when the day and night are equal: the length of the day is then 12 hours; the

sun is ascending six hours, and descending the same time. This is the case twice a year, in spring and in autumn, when the sun is on the equator. When the sun is in this situation the horizon of every place is divided into two equal parts by the circle bounding light and darkness, generally. The vernal equinox is on 21 March, and marks the beginning of spring; the autumnal is generally on 23 September, which is considered the commencement of autumn; at all other times the length of the day and of the night are unequal, and their difference is the greater the more we approach either pole, and in the same latitude it is everywhere the same. On the equator this inequality entirely vanishes; there, during the day, which is equal to the night, the sun always ascends six hours and descends six hours. In the opposite hemisphere of our earth the inequality of the days increases in proportion to the latitude: the days increase there while they diminish with us, and vice versa. The points where the ecliptic intersects the equator are called equinoctial points. The vernal equinoctial point was formerly at the entrance of the constellation of Aries; hence the next 30 degrees of the ecliptic, reckoned eastward, have been called Aries; but this point long ago deserted the constellation of Aries, and now stands in Pisces; for it is found by observation that the equinoctial points, and all the other points of the ecliptic, are continually moving backward or westward; which retrograde motion of the equinoctial points is what is called the precession of the equinoxes. This retrograde motion is quite analogous to the revolution of a gyroscope weighted at one end and balanced in the middle. It is due to the gravitational pull exerted by the sun and moon on the equatorial protuberances of the earth, which is a spheroid, not a sphere. It appears from the result of calculations that the path of the poles of the equator is nearly a circle, the poles of which coincide with those of the ecliptic, and that the pole will move along that circle so slowly as to accomplish the whole revolution in about 25,800 years. The diameter of this circle is equal to twice the inclination of the ecliptic to the equator, or about 47°. Now, as the ecliptic is a fixed circle in the heavens, but the equator, which must be equidistant from the poles, moves with the poles, therefore the equator must be constantly changing its intersection with the ecliptic. And from the best observations it appears that the equator cuts the ecliptic every year 50.25" more to the westward than it did the year before; hence the sun's arrival at the equinoctial point precedes its arrival at the same fixed point of the heavens every year by 20 minutes 23 seconds of time, or by an arc of 50.25". Thus, by little and little, these equinoctial points will cut the ecliptic more and more to the westward, till, after 25,800 years, they return to the same point. The precession of the equinoxes is not absolutely uniform, for the forces inducing the precession depend on the position of the sun and moon with reference to the earth. Thus at the vernal and autumnal equinoxes the sun is in the plane of the equator, and can cause no precession. Another important factor in causing the precession to vary is the fact that the plane of the moon's orbit is somewhat inclined to the ecliptic. Besides causing the component of the

moon's attraction in the plane of the ecliptic to vary, this inclination introduces a component perpendicular thereto. This is an important factor in causing the path of the pole of the equator to be a wavy curve rather than a precise circle. This wavy motion is known as nutation. See DAY; ECLIPTIC; EQUATOR; GYROSCOPE.

**EQUINOXES**, Precession of the, the motion of the equinoxes along the ecliptic due to the change in the direction of the earth's axis of rotation, caused by the attraction of the moon and sun on the protuberant equatorial ring of the earth. See EQUINOX.

**EQUISETUM**. See *Equisetales* under FERNS AND FERN ALLIES.

**EQUITES**, ěk'wī-tēz. See EQUESTRIAN ORDER.

**EQUITY**. The name equity was given to that supplemental law which was formerly administered exclusively in the Chancery Courts of England, and which was designed to work out substantial justice in cases where that could not be obtained normally in the common law courts. The common law became very strict and narrow at a very early period, and if a suitor could not bring his case in such a form as to fall within one of the recognized writs, he was without a remedy. For example, the common law courts had no provision for the preventing of wrongs, however imminent they might be. Here the Chancery Court could step in, and by injunction against the person threatening a wrong, cover this contingency. A body of law subsidiary to the common law therefore arose, whose administration was in the hands of the Chancellor (q.v.). Hence arose the curiosity presented for an extended period in English legal history, in which a suitor's chances of success depended largely upon the particular court in which he brought his action. The existence of this body of law led ultimately to scandals and vexatious delays; the rules of equity varied at different periods, depending a good deal upon the personal idiosyncrasies of the Lord Chancellor for the time being, and justifying Selden's sneer, that "they should make the standard for equity the Chancellor's foot." Between the 17th century and the beginning of the 19th century, however, equity became almost as fixed as the common law, but the systems were always kept distinct until the passing of the Judicature Acts of 1873 and 1875, under which they were consolidated. Since 1875 law and equity have been administered equally to all the divisions of the High Court of Justice, and if there is any conflict between the rules of law and equity, those of equity are to prevail.

After the Revolution, the States of the American Union continued the English system; but while some of them have kept strictly to that system and have distinct courts of law and of equity, other States have law and equity administered by the same judges and courts, at one time sitting as courts of law and at another time as courts of equity.

Some of the rules and maxims of equity are: "Equity considers that as done which ought to be done." "Equity acts in *personam*." "He who comes into equity must do so with clean hands." "Between equal equities priority of time will prevail." "Between equal equities

the law will prevail." "No right without a remedy." "When a court of equity has once acquired jurisdiction of a cause it will continue to act until the matter is finally disposed of."

Equity is divided into three great classes or divisions: Equitable titles, equitable rights and equitable remedies. Equitable titles are those which are recognized only by a court of equity, as where, when a person gave a value for a *chose in action* which was assigned to him, the assignment was not recognized at law, as it would violate the rules against champerty and maintenance, but equity allows the assignee to bring suit in the name of the assignor. Equitable rights arise where a guardian enters into a transaction with his former ward a very short time after the ward has obtained his majority. If within a reasonable time the ward returns what he received from the guardian the guardian will, in equity, be compelled to return the property to the ward. Equitable remedies arise in those cases in which the law recognizes a right but cannot enforce it, as where a contract is made for the sale of a piece of property, if the seller refuses to convey, the purchaser's remedy at law is for damages for breach of the contract; but in equity the court will decree specific performance. Generally this applies only to real estate, because if it is personal property, after the damages are recovered other personal property of the same kind can be purchased; but if the personal property is of such nature that it cannot be duplicated, such as a painting by a particular artist, equity will affirm relief in the way of specific performance.

Suits in equity are commenced by a bill or petition. The bill may be amended, or, if the proceeding have gone too far for that, a supplemental bill may be filed. The defense is by demurrer, plea or answer. The judgment of the court is called a decree, and the relief granted is such as to affect all the parties, and is adapted to the facts and circumstances of that particular case. The general rules of evidence are the same as in a proceeding at law, but the answer to the bill, if made under oath, is evidence for the defendant in so far as it is responsive to the bill.

Consult Kerly, D. M., 'Historical Sketch of the Equity Jurisdiction of the Court of Chancery' (London 1890); Pomeroy, J. N., 'Equity Jurisprudence as Administered in the United States' (3d ed. San Francisco 1905); Spence, G., 'Equity Jurisdiction of the Courts of Chancery' (2 vols. London 1846-49).

**EQUITY, Courts of.** See COURT.

**EQUITY OF REDEMPTION.** The right, enforceable in equity, of a mortgagor to redeem the mortgaged property, even after forfeiture, by paying the debt with interest and costs. This right is barred only by strict foreclosure proceedings or by one of the various statutory procedures provided for the purpose, or by the mortgagee taking possession of the property after forfeiture and holding it for the period required by the statute of limitations. The term is also applied to the interest or estate remaining in the mortgagor in property he has mortgaged. See CHANCERY; EQUITY; FORFEITURE; MORTGAGE; REDEMPTION.

**EQUIVALENT,** having equal value, power, area or volume. In chemistry, (1)

atomic weight. (2) The equivalent of a base is the number of grams of it which will neutralize one gram-molecule of a monobasic acid. The equivalent of an acid is the number of grams of it which will neutralize one gram-molecule of caustic potash or soda. See CHEMISTRY.

**EQUULEUS,** ẽ-kwoo'le-ũs, in astronomy ("the Colt" or "Little Horse"), one of the 48 original constellations of the Almagest, situated just between the head of Pegasus and Delphinus. It has Aquarius on its south side. It is a very inconspicuous constellation, its brightest star being of the fourth magnitude. Also a name given to the rack, or instrument of torture.

**ERA,** the largest unit of geologic time. According to United States Geological Survey usage, all geologic time is divided into the following eras, beginning with the oldest: Proterozoic, Palæozoic, Mesozoic, and Cenozoic. By some authorities one and sometimes two other eras are recognized. The earlier part of the Proterozoic is split off under the name Archeozoic or Azoic, and to its latter divisions is given the name Proterozoic or Eozoic. The latter part of the Cenozoic is also sometimes split off to form the Psychozoic. But these names are not generally recognized, and the official classification is into the four eras first given. These divisions are in part based on palæontologic evidence, that is on changes in fossil form, and in part on structural considerations. With few exceptions there is unconformity (q.v.) between the Proterozoic and the Palæozoic. The close of the Palæozoic is marked by the folding of the Appalachian Mountains and the close of the Mesozoic by the Rocky Mountain uplift. See CHRONOLOGY; EPOCH; PROTEROZOIC; PALÆOZOIC, etc.

**ERA OF GOOD FEELING, 1817-24.** In American political history, Monroe's two administrations, up to the canvass for his successor. There were practically no issues, and but one party. The issue on which the Federalist party was founded had long since been appropriated by the Democrats, and it had foolishly taken theirs in exchange. The embargo and the war had created a sectional issue; but peace ended that and left no pretext for division. The Hartford Convention (q.v.) had killed the old leaders politically; the new ones had joined the Democrats, because the embargo and the war had driven New England capital from commerce into manufactures, and it wished to demand tariff favors from the administration. But it was a decade before the tariff and internal improvements, the next division lines, assumed theoretic consistency. Monroe issued an inaugural in 1817 especially to placate the Federalist; and followed it by a tour through New England where he was received with immense ovations from both parties. He was unanimously re-elected in 1820, save for the whim of one elector. The personal factions which contested the field in 1824, the coalition (q.v.) which decided the result, and the Jacksonians' fury over it, effectually ended the good feeling.

**ERAGROSTIS,** a large genus of the grasses, belonging to the *festuceæ*. There are over 100 species of the *Eragrostis*, of which there are in America about 30, either native

or naturalized. The species are from a few inches to several feet in height, and are found in nearly all parts of the United States. None are of commercial importance, and such as are used for hay are accidental growths among cultivated grasses. The strong scented *Eragrostis* (*E. major*), is an ill-smelling grass, but tall, erect and rather handsome, owing to the shape and size of its leaves. It is found in almost every part of the United States and Ontario, naturalized from Europe.

**ERAN, Eranian.** See IRAN, IRANIAN.

**ERARD, a-rär, Sébastien**, French musical instrument maker: b. Strassburg 5 April 1752; d. Passy, near Paris, 5 Aug. 1831. He went to Paris at 18, and with his brother, Jean Baptiste, produced pianofortes so superior to any previously made in France that his fame quickly spread, and orders flowed in upon him from all quarters. During the Revolution he went to England and established a manufactory in London, and when peace was restored his life was passed between that city and Paris. His improvements upon the harp, more especially that of the double movement, the principle of which he afterwards communicated to the piano, entitled him to high merit as an inventor.

**ERAS, a-räs, Wolfgang**, German economist: b. Schönfeld, 1843; d. 1892. He received his education at the universities of Leipzig, Jena and Berlin. In 1866-70 he served as secretary to the Rhenish-Westphalian Industrial Association and from 1871 to 1886 was recorder of the Chamber of Commerce at Breslau. After 1886 he was secretary of records of the Silesian Textile Manufacturers' Association. He published 'Der Währungsstreit' (1883); 'Einrichtungen für die Binnenschiffahrt an deutschen und holländischen Handelsplätzen' (1885); 'Unser Handel mit den Balkanländern' (1891). He edited the *Jahrbuch für Volkswirtschaft* in 1868-69.

**ERASISTRATUS, ér-a-sís'tra-tūs**, Greek physician. He lived in the 3d century before the Christian era, was the court physician to Seleucus Nicator, king of Syria, and rendered himself famous by the sagacity with which he discovered the malady of Antiochus, the king's son. He subsequently went to Alexandria, where he devoted himself to the study of anatomy. He was the first who systematically dissected the human body, and his description of the brain and nerves is much more exact than any given by his predecessors. He classified the nerves into nerves of sensation and of locomotion, and it is said had almost stumbled upon the discovery of the circulation of the blood, for he explained that the veins and the arteries had their origin in the motion of the heart. He was remarkably adverse to blood-letting and the giving of purgatives, relying chiefly upon diet and regimen, bathing, exercise, friction and the most simple articles of the vegetable kingdom, for the restoration and preservation of health. His professional followers, a body of physicians of note, were known as Erasistrateans. He wrote several works on anatomy, practical medicine and pharmacy, of which only the titles remain, together with a great number of short fragments preserved by Galen and other ancient medical writers. Consult Fuchs, 'De Erasistrato Capila

Selecta' (in 'Hermes,' Vol. XXIX, Berlin 1894); Hieronymus, 'Erasistrati et Erastitratocorum Historia' (Jena 1790); Susemihl, 'Geschichte der griechischen Litteratur' (Vol. I, Leipzig 1892).

**ERASMUS, è-ráz'müs, Saint**, Syrian bishop and martyr. He is said to have been put to death under Diocletian by disemboweling, and his martyrdom is frequently represented in art. As he was counted as one of the 14 Succorers of the Distressed, so was his aid especially invoked in affections of the stomach. The remaining 13 Succorers are Saints Acasius, Blasius, Christopher, Cyriacus, Dionysius the Areopagite, Egidius, Eustathius, George the Martyr, Pantaleon, Vitus, Barbara, Catharine and Margaret. June 2 is the saint's day of Erasmus. On the capture of Formiæ (the reputed scene of the martyrdom of Erasmus in the 3d century), by the Saracens in 842, the body of the saint, or what was popularly believed to be his, was removed to Cajeta.

**ERASMUS, Desiderius**, Dutch scholar: b. Rotterdam, probably 28 Oct. 1467; d. Basel, Switzerland, 12 July 1536. He was the illegitimate son of one Gerhard of Gouda. The name by which he is known is merely the Latin and Greek rendering of Gerhard, Desiderius, the Latin, and Erasmus, or, more correctly, Erasmus, the Greek equivalent. He was a singing-boy in the cathedral of Utrecht till his ninth year, then entered the school at Deventer, where he displayed such brilliant powers that it was predicted that he would be the most learned man of his time. At the age of 17 he assumed the monastic habit near Gouda, but the bishop of Cambrai delivered him from this constraint by taking him as a Latin secretary. In 1492 he was ordained, and went to Paris to perfect himself in theology and polite literature, and there became the instructor of several rich Englishmen, from one of whom—Lord Montjoy—he received a pension for life. He accompanied them to England in 1497, where he was graciously received by the king. He returned soon after to Paris, and then traveled into Italy to increase his stock of knowledge. He now asked a dispensation from the vows of his order, which the Pope granted him. He visited Venice, Padua and Rome; taught at Louvain 1502-04; but brilliant as were the offers here made him, he preferred the invitation of his friends in England. When he visited the lord-chancellor, Sir Thomas More (1506), without making himself known to him, the chancellor was so delighted with his conversation that he exclaimed, "You are either Erasmus or the devil." He made his third visit to England in 1509. He was offered a benefice, but was unwilling to fetter himself by an office of this kind. He was for a short time professor of divinity and Greek at Oxford. He afterward traveled through Germany and the Netherlands, and went to Basel, where he had his works printed by Froben and acted as general adviser of Froben's presses, which he raised to be the most important in Europe.

To profound and extensive learning Erasmus joined a refined taste and a delicate wit. Naturally fond of tranquillity and independence, he preferred the pleasure of literary ease and retirement to the pomp of high life. All through life he suffered from a bad stomach;

he could not eat nor bear the smell of fish; as he humorously put it, "his heart was Catholic, but his stomach was Lutheran." For a man of a detached and inquiring mind like his, partisanship was impossible; but he wished to see the power of the clergy broken as the main obstacle to the spread of liberal ideas. But he recoiled from the fanaticism which accompanied the Reformation, and had no sympathy with the evangelicism to which it gave birth. Indeed theological disputation had no attractions for him, although it has been said of him that he laid the egg which Luther hatched. Luther spoke for the low-born; Erasmus for the more cultured class. He implies that the revelation of religion has added nothing to life that makes it worth living. The incisive way in which he handled the religious abuses of his time prepared men's minds for Luther's work, and he was also free and outspoken in his criticism of the treatment meted out by kings to their subjects. The great service he rendered was in fighting the battle of sound learning and plain common sense against obscurantism, and in emphasizing the sovereign place of reason as the ultimate guide in all questions, religious and political not excepted. Besides his editions of various classics, the first edition of the Greek Testament from MSS. (with Latin translation), and his other philological and theological writings, may be only mentioned his well-known book in praise of folly, 'Encomium Moriae,' and his 'Colloquies' (1519). His letters are very valuable in reference to the history of that period. (See COLLOQUIES OF ERASMUS; PRAISE OF FOLLY, THE). Consult 'Lives' by Knight (1726); Jortin (1748); Burigny (1752); Durand de Laur (1874); Feugère (1874); Drummond (1873); Froude (1894).

**ERASMUS MONTANUS**, comedy in five acts by Holberg; translated by O. J. Campbell and F. Schenck. It was written before 1723 but not produced till 1747. It did not at once score such a success as many of his other comedies. Now, however, it is considered not only to be an excellent picture of the times; but it has its value for all times as showing the contrast in life between appearance and reality and also the demand, strong then as now, that the individual seek the truth for its own sake.

Erasmus, the son of a well-to-do peasant, has studied at the university and now is on a visit to his parents in the village, called 'The Hill.' As he has tasted of the tree of knowledge, he wants to show off his great learning, claiming to be able to "prove" in a logical way any assertion, however foolish, he makes. His arrogant ways and hair-splitting methods arouse the antagonism of all. Through the "Lieutenant," who is Holberg's mouthpiece in the comedy, Erasmus is properly punished, and he is finally compelled to renounce the only true assertion he has made, viz., that the earth is round.

In the leading character, Erasmus Montanus, with his insufferable intellectual conceit, acquired at the university, Holberg attacks the methods and aims of this seat of learning, ridicules the academic pedantry, the formalism of logic and the Latin disputations as practised at the time. Holberg knew that among

the peasants, ignorant though they were and often so sadly neglected, there was a good deal of common sense. In Jacob, Erasmus' brother, Holberg has presented, in a most humorous manner, the contrast to the vain and empty "learning" of the hero. In Peter the deacon, Jesper the bailiff, Jeronimus whose conservatism shrinks in terror from anything that is new, Holberg shows his mastery in drawing character, and in the scenes in which they figure, the author's humor is at its best. Many sayings in this comedy are common property in the current speech of the Scandinavian countries even to-day. Consult Campbell, 'The Comedies of Holberg.'

#### GISLE BOTHNE.

**ERASTIANS**, in England, a name applied to a party that arose in the 17th century, denying the right of autonomy to the church—a right neither maintained nor denied by Erastus (q.v.). The Erastian controversy broke out at the time of the Westminster Assembly. The leading Erastians in that assembly were Lightfoot and Coleman, who were supported by Selden, Saint John and Whitelocke, three noted lawyers, in the House of Commons. The Erastians in England would subordinate the government of the Church to the authority of the State, both as regards doctrine and discipline. Since the time of the Reformation the controversy has been confined chiefly to the Church in Scotland where the term Erastian has been applied to those denying the power of the Church to nullify the operation of lay patronage. Consult Cunningham, 'Historical Theology' (Vol. II, Edinburgh 1862); Henson, 'English Religion in the Seventeenth Century' (London 1903).

**ERASTUS, Thomas** (a Latin translation of his name LIEBLER or LIEBER), German theologian and physician: b. Auggen, near Mühlheim, 1524; d. Basel, Switzerland, 1583. He studied theology at Basel (where he Grecized his name), and philosophy and medicine at Bologna and Padua. After nine years in Italy, he was appointed physician to the counts of Henneberg. In 1558 he received an invitation to go to the court of the Elector Palatine, and accepted it. There he became first physician and Privy Councilor and professor of medicine at Heidelberg. He removed from Heidelberg to fill the chair of medicine at Basel in 1580. Shortly before his death he had been appointed professor of ethics. Erastus was a skilful physician and a man of upright character, an equally vigorous writer against "the new medicine of Philip Paracelsus" (1572) holding that the only true road to knowledge is to be found in experimental investigation, and not in astrology, magic and other obsolete practices. In theology he was a follower of Zwingli, and his fame now rests on his strenuous opposition to Calvinist discipline and Presbyterian order. In 1564 he maintained the Zwinglian doctrine of the Lord's Supper at the conference of Maulbronn, and it was in defense of it that he wrote 'Vom Verstand der Wort Christi "Das ist Mein Leib"' (1565). Erastus was excommunicated on a false suspicion of heresy, founded on a correspondence with Unitarians of Transylvania, but was restored in 1575. His chief work is a treatise on excommunication entitled 'Explicatio gravissimæ quæstionis utrum Excom-

*municatio mandato nitatur divino, an excogitata sit ab hominibus.* This was answered by Beza in his 'De vera Excommunicatione et Christiano Presbyterio' (1590). Erastus maintained that no member of the church should be excluded from her communion as a punishment for sin. Punishment is "the special duty and office" of the civil magistrate. Consult Bonnard, 'Thomas Eraste et la discipline ecclésiastique' (1894); Lee, 'The Theses of Erastus Touching Excommunication' (Edinburgh 1844). See ERASTIANS.

**ERATO**, ɛr'a-tō (Gr. *erāō*, I love), one of the nine Muses, whose name signifies loving, or lovely. She presides over lyric and especially amatory poetry, the songs of lovers, and touches, as Ovid, in his 'Art of Love,' informs us, the hearts of the coldest maidens by her tender lays. She is represented as crowned with roses and myrtle, in the act of playing, the plectrum in her right hand and the lyre in her left.

In zoology *erato* is a genus of cowries belonging to the family of *cypræidæ*. (See MUSES.) *Erato* is also the name of one of the planetoids.

**ERATOSTHENES**, ɛr-a-tōs'thē-nēz, Greek astronomer, geographer and philosopher: b. Cyrene, Africa, 276 B.C.; d. about 196 B.C. He studied in his native town and Alexandria and then went to Athens. He became librarian at Alexandria, and improved the science of mathematical geography, which he reduced to system; but he gained his greatest renown by his investigations of the size of the earth, his estimate of the circumference of which was surprisingly near the truth. He wrote also on chronology, grammar, philosophy, literature, history and the drama, and was considered no mean poet. He rendered much service to astronomy and first observed the obliquity of the ecliptic. He is said to have starved himself to death after becoming blind. The extant fragments of his writings were collected by Bernhardt in his 'Eratosthenica' (1822); his geographical fragments were published by Berger in 1880.

His commentary on 'Timæus' (of Plato) seems to have been highly valued in his day, and his philosophical dialogues became, as they were intended, popular. His 'On the Old Comedy,' which treated of the foremost comic poets in 12 or more books, was looked upon as a really great work. In it he dealt with the works of the poets and the general life and management of the theatre. He may be said to have been the father of exact chronology since he endeavored to ascertain the dates of the principal events in history, politics and literature from the fall of Troy to his own day. In his 'Katasterismoi' he deals, in an interesting manner, with the relation existing between the popular Greek mythology and the constellations. In his 'Geography,' issued in three books, he made the first known attempt to treat the subject scientifically, historically and experimentally. He wrote two books on mathematics, which have not survived him, and he worked out a "sieve" to discover all prime numbers.

**Bibliography.**—Berger, 'Die geographischen Fragmente des Eratosthenes' (Leipzig 1870); Bernhardt, 'Eratosthenica' (Berlin 1822);

Christ-Schmidt, 'Geschichte der griechischen Litteratur' (Munich 1911); Hillier, 'Eratosthenis Carminum Reliquæ' (Leipzig 1872); Maass, 'Eratosthenica' (Berlin 1883); Olivieri, 'Pseudo-Eratosthenis Catasterismi' (in *Mythographi Græci*) III, Leipzig 1897); Robert, 'Eratosthenis Casasterismorum Reliquiæ' (Berlin 1878); Schaubach, 'Katasterismoi' (1795); Seidel, 'Geographical Fragments of Eratosthenes' (1799); Stiehle, 'Zu den Fragmenten des Eratosthenes' (in *Philologus*, supplementary, Vol. 2, Göttingen 1863); Susemihl, 'Geschichte der griechischen Litteratur an der Alexandrinerzeit' (Leipzig 1892).

**ERANZO**, ɛ-row'thō, Catalina de, Spanish-American heroine: b. San Sebastian, Viscaya, 10 Feb. 1585; d. Cuitaxtla, near Orizaba, Mexico, 1650. The daughter of a good family of Biscay, she was placed at an early age in a Dominican convent of her native city with a view to entering on a religious state. Soon she attracted attention by her originality of character and her passionate love of liberty. In consequence of a dispute with one of her superiors, Catalina, on 18 May 1607, being then a novice, she scaled the walls and escaped to the woods, where, subsisting on herbs and roots, she remained three days and in that time transformed her garb into that of a man. Proceeding to Vittoria she found employment as an amanuensis. Thereafter she wandered over a great part of Spain, being employed many times in divers occupations usually reserved to the male sex. After some years she embarked on a Spanish vessel bound for America as a member of the crew. On arrival in the New World she deserted and secured employment with a rich merchant, who later made her administrator of his affairs. After many adventures in which she managed successfully to conceal her sex she enlisted as a soldier and won distinction fighting against the natives, winning the grade of ensign. Her disposition led her into many scrapes, principally duels, in which she was not always victorious. More than once she slew her opponents in duels and in quarrels and twice she was reprieved after sentence of death had been imposed on her. Being gravely wounded in a quarrel at Cuzco, Catalina believed herself to be dying and longed to reveal her sex. She revealed the secret to the priest who visited her. She afterward met Bishop Augustin de Carvajal to whom she related the story of her life, telling him she was willing to submit to examination by a committee of matrons, adding that she still preserved her purity. It was proved by the matrons that she had spoken the truth. Catalina lived in a convent in 1620-22, then traveled to New Granada, and sailed for Spain, arriving in Cadiz, 1 Nov. 1624. Her fame had preceded her and she was enthusiastically received. In Madrid she was received by Philip IV, who granted her a life pension of 800 crowns. She journeyed to Rome, where she narrated her eventful history to Pope Urban VIII, who gave her permission to dress in male attire for the rest of her life. Returning to Spain she resided in Seville until 1630, when she set out for Mexico, where she served in the army for some years and afterward with a string of pack-mules began trade between Mexico City and Vera Cruz. She was buried at Orizaba. In 1653 the history of her life, written

by herself, was published in Mexico. This autobiography under the editorship of Joaquin Maria Ferrer was issued at Paris in 1829 under the title 'Historia de la Monja Alferez, etc., escrita por ella misma con notas y piezas justificativas.'

**ERB, Wilhelm Heinrich**, German neuropathologist: b. Winnweiler, Bavaria, 1840. He received his education at the universities of Heidelberg, Erlangen and Munich. From 1880 to 1883 he was professor of special pathology and therapy at Leipzig, thereafter removing in the same capacity to the University of Heidelberg, where he was appointed clinical director. He has made extended investigations on electrotherapy and neuropathology. His published works include 'Handbuch der Krankheiten der peripheren cerebro-spinalen Nerven' (2d ed., 1876); 'Handbuch der Krankheiten des Rückenmarks und des verlängerten Marks' (2d ed., 1878); 'Handbuch der Elektrotherapie' (English trans. by Putzel, 1883); 'Ueber die neuere Entwicklung der Nervenpathologie' (1880); 'Dystrophia Muscularis Progressiva' (1891); 'Gesammelte Abhandlungen' (1910).

**ERBEN, Henry**, American naval officer: b. New York, September 1832; d. 1909. He was graduated at the United States Naval Academy in 1854, became commander in 1868, rear-admiral in 1894, and was retired in the latter year. During the Civil War he served with Admiral Farragut in the Gulf of Mexico and on the Mississippi River with Admiral Dupont, etc. In 1866-69 he was on duty in South America; later, in command of the *Tuscarora*, he made deep-sea soundings in the Pacific; afterward commanded the *Pensacola* in a trip round the world, and in 1891-92 was commandant of the New York Navy Yard and of the European squadron in 1893-94. He voluntarily returned to service in the Spanish-American War.

**ERBEN, Karl Jaromir**, Czech poet: b. Miletin 1811; d. 1870. He received his education at the University of Prague, was a leading figure in the Czech troubles of 1848 and two years later was appointed secretary of the Museum at Prague and archivist of the town in 1851. In 1855 he published the important historical work 'Regesta Diplomatica nec non Epistolaria Bohemiae et Moraviae.' His fame spread through his volume of ballads, 'Kytice,' and his collections of folksongs and popular melodies. In 1863-65 his 100 Slavic folk tales earned him a reputation similar to that of the Grimm Brothers. He also edited the vernacular works of John Huss. Consult Novák, 'Cechische Litteratur der Gegenwart' (Leipzig 1907).

**ERBIUM**, a rare metallic element, occurring in the form of a tantalate or silicate in the minerals gadolinite, fergusonite and euxenite, and as a phosphate in the mineral xenotime. It has the chemical symbol Er, or E, and an atomic weight of about 167.7. The oxide of erbium, Er<sub>2</sub>O<sub>3</sub>, has a pale rose color, is infusible, and when strongly heated glows with a brilliant green light. It is not affected by water, but dissolves slowly in hot acids with the formation of the corresponding erbium salts. Most of the salts are rose-colored and the haloid compounds are also deliquescent. The name

erbium is derived from Ytterby, Sweden, where the mineral gadolinite is found. The recognition of erbium as a new element is attributed to Mosander (1843), but the metal itself has not yet been isolated.

**ERBT, Wilhelm**, German biblical scholar: b. Berlin 1876. He was educated at Halle, Greifswald, Leipzig and Wittenberg. He has held several pastorates and taught in various seminaries. His works on Hebrew religion and history has brought him an international reputation. They include 'Die Purimsage in der Bibel' (1900); 'Jeremia und seine Zeit' (1902); 'Sicherstellung des Monotheismus' (1903); 'Israel und Juda' (1903); 'Die Urgeschichte der Bibel' (1904); 'Die Hebräer' (1906); 'Elia, Elisa, Jona' (1907); 'Handbuch zum Alten Testament' (1909); 'Kirchengeschichte' (5th ed., 1913); 'Das Marcusevangelium' (1911); 'Von Jerusalem nach Rom' (1912); 'Geschichte der Religion in der Alten Welt' (1913).

**ERCILDOUNE, Thomas of**. See RHYMER, THOMAS.

**ERCILLA Y ZUNIGA**, är-thel'yä è thoo-nyé'gä, Alonzo de, Spanish soldier and epic poet: b. Madrid, 7 Aug. 1533; d. there, 29 Nov. 1594. He was of noble family and was a close friend of the prince who afterward became Philip XI of Spain. His father died when the boy was less than a year old, and his mother, who had charge of the family estates and who was related to the royal families of several of the European countries, made visits to Germany, Austria, Hungary and other European courts, taking Alonzo with her. She also succeeded in getting him appointed page at the court of Spain. Before he had reached man's estate he had seen much of the court and was one of the most traveled persons in Spain. At the age of 22 Ercilla sailed for South America on the Spanish squadron sent out at the king's command. In 1557 he accompanied the new governor of Chile, Garcia Hurtado e Mendoza, from Panama to Lima. An insurrection breaking out among the Araucanian Indians of Chile, Ercilla joined an expedition sent against them. The difficulties the Spaniards had to encounter, the heroic resistance of the natives, and the multitude of gallant deeds by which the war was signalized, inspired the young and brave Ercilla with the idea of making it the subject of an epic poem, to which he gave the name 'La Araucana.' While on this campaign Ercilla and a fellow officer, Pineda, were arrested by the commanding officer and condemned to death. They spent the night in the death chapel; and in the morning their sentence was commuted to imprisonment while the expedition lasted and final banishment from the country. Ercilla recovered his liberty after a short time and frequently distinguished himself for bravery in the remaining part of the campaign. Returning to Spain in 1562, during a two years' journey, he visited Germany for the third time, Hungary, France and Austria. He was knighted and made Duke of Lerna on his return to Spain. In 1575 he went to Italy and was received by the Pope. Later he again visited Germany, became a friend of the Emperor Maximilian and attended his coronation as King of Bavaria. Later he was sent on diplomatic missions by the King of Spain. He seems

to have lost many of his friends and much of his property in his old age. He returned to Spain after having finished the first part of his epic. In 1570 he had married Maria Bazan at Madrid, whose charms and virtues are celebrated by him in various passages of his poem. In 1569 the first 15 cantos of his poem appeared; in 1578 a second part, and in 1590 a third part were added, making in all 37 cantos. The 'Araucana' is an historical epic in the octave measure in which the author confines himself, with the exception of some episodes and a few fictions, to the exact historical course of events. Hence the poem often assumes almost the character of a chronicle. In addition to its poetic merits, which are not few, 'L'Araucana' is very valuable for the information it gives of the conditions in the Spanish colonies of America. Ercilla is impartial even to his Indian enemies whom he admires. His literary work is good and his descriptions of times, manners and personages are vivid and bear the stamp of truth. His battle pictures are especially vivid. Consult Barros Arana, 'Historia General de Chili' (Santiago 1884). Lope de Vega has taken from the epic of Ercilla the materials for his piece 'Araucana Conquered.' The best editions are those published at Madrid in 1776 and 1876 and 1828. It has been translated into Italian, and twice into French. See ARAUCANA, LA; ARAUCANIANS.

**ERCKMANN-CHATRIAN**, ər'kman-shā-trē-än', the combined surnames of two Frenchmen, natives of Alsace, who collaborated in writing romances. EMILE ERCKMANN: b. Phalsbourg, 20 May 1822; d. Lunéville, 14 March 1899. Having completed his studies in the communal college of his native town, he went to Paris in 1842 to study law. Returning to Phalsbourg in 1847 because of a serious illness, he began to turn his attention to romance writing during his convalescence. It was about this time (1848) that he met his collaborateur, LOUIS GRATIEN CHARLES ALEXANDRE CHATRIAN, b. Soldatenthal, 18 Dec. 1826; d. Raincy, 3 Sept. 1890. Chatrian was a member of an old family of glass-work owners, and it was intended that he should follow the same craft. Instead of doing so, however, he left his native village and became a teacher in Phalsbourg, where he made the acquaintance of Erckmann. For several years the stories produced by this copartnership were published in obscure newspapers, both in Strassburg and Paris, but about 1860 their graphic romances of Alsace in the time of Napoleon I gained a rapid popularity. Their stories, though not possessing any particularly high literary value, were distinguished especially for their sincerity, their striking descriptions and their clever characterizations. Their published works include 'L'Illustre Dr. Mathéus' (1859); 'Contes de la Montagne' (1860); 'Contes Fantastiques' (1860); 'Maitre Daniel Rock' (1861); 'Les Contes des Bords du Rhin' (1862); 'L'Invasion, ou le Fou Yégoif' (1862); 'Joueur de Clarinette' (1863); 'L'Ami Fritz' (1864); 'Histoire d'un Conscrit de 1813' (1864); 'Madame Thérèse' (1864); 'Waterloo' (1865); 'Histoire d'un Homme du Peuple' (1865); 'La Guerre' (1866); 'La Maison Forestière' (1866); 'Le Blocus' (1867); 'Histoire d'un Paysan' (4 vols., 1868-70); 'Le Juif Polonais' (1869); 'Histoire d'un Sous-Maitre'

(1869); 'Histoire du Plébiscite' (1872); 'Les Deux Frères' (1873); 'Une Campagne en Kabylie' (1874); 'Le Brigadier Frédéric' (1874); 'Hugues le Loup' (1876); 'Maitre Gaspard Fix' (1876); 'Souvenirs d'un Ancien Chef de Chantier' (1876); 'Contes Vosgiens' (1877); 'Le Grand-Père Lebigre' (1880); 'Quelques Mots sur L'Esprit Humain' (1880); 'Les Vieux de la Vieille' (1881); 'Le Banni' (1882). Some of these have been collected into groups, in accordance with their contents: 'Romans Nationaux' (1867); 'Contes et Romans Populaires' (1867); 'Contes et Romans Alsaciens' (1876). They also dramatised successfully some of their novels: 'L'Ami Fritz' (1867); 'Le Juif Polonais' (1869, known in its English adaptation by L. Lewis as 'The Bells' and produced with considerable success by Sir Henry Irving); 'Madame Thérèse' (1882); 'Les Deux Frères' (1884, known in its dramatised form as 'Les Rantzau'). English translations are available of practically all these publications. There are also German translations of many of them and of some of these a collection was made (12 vols., Stuttgart 1882). After Chatrian's death Erckmann wrote a few books alone, none of which, however, achieved much success. In regard to their methods of collaboration it became known that when the two friends met they elaborated the scheme of a work; then Erckmann wrote it. Chatrian corrected it, and sometimes put it in the fire. Sometimes Erckmann would even be required by his friend to write his story over three times. Chatrian also acted as business manager, made all contracts and collected all royalties. Shortly before his death a break occurred between the two old friends which led to a law suit, but was finally compromised. (See L'AMI FRITZ). Consult Acker, P., 'Erckmann-Chatrian' (in *La Revue de Paris*, Vol. XIX, No. 6, p. 347, Paris 1912); Anon., 'Erckmann-Chatrian' (in *The Bookman*, Vol. XL, p. 494, New York 1915); Claretie, J., 'Erckmann-Chatrian' (in 'Celebrités Contemporaines,' Paris 1883); Hinzelin, E., 'La Verité sur Erckmann-Chatrian' (in *La Revue*, Ser. VI, Vol. LXXXIX, p. 310, Paris 1911); Velde, M. S. van de, 'French Fiction of To-day' (2 vols., London 1891).

**ERDÉLYI**, ər'däl-yē, János, Hungarian poet: b. Kapos 1814; d. 1868. In 1848 he became director of the national theatre at Pest and in the following year was appointed to the chair of philosophy at Sárospatak. He published a collection of popular songs of Hungary together with the principal legends entitled 'Népdalok és mondák' (3 vols., 1848). In 1851 he published a collection of Hungarian proverbs. His smaller works have been issued in German under the titles 'Bahnen und Palmen' (1886) and 'Studien' (1890).

**ERDMAN ACT.** See ARBITRATION, INDUSTRIAL.

**ERDMANN, David**, German theologian: b. Güstebiese, Brandenburg, 1821; d. 1905. He received his education at the University of Berlin and in 1850 was appointed assistant preacher at the cathedral there. Six years later he was appointed to the chair of theology at Königsberg. In 1864 he was made superintendent-general of Silesia, and 25 years later he became superior consistorial counselor. In 1900 he retired. His published works include 'Lieben und Leiden



der ersten Christen' (1854); 'Die Reformation und ihre Märtyrer in Italien' (1855); 'Luther und die Hohenzollern' (2d ed., 1884); and a commentary on 'Samuel' in Lange, 'Bibelwerk' (1873). Consult Eberlein, 'Aus einem reichen Leben: Blätter der Erinnerung an David Erdmann' (Berlin 1907).

**ERDMANN, Johann Eduard**, German philosopher: b. Wolmar, in Livonia, 13 June 1805; d. Halle, 12 June 1892. He studied theology at the universities of Dorpat and Berlin, coming there under the influence of Hegel (q.v.). In 1829 he became a clergyman in his native town. In 1832 he returned to Berlin, became a member of the philosophic faculty of the university in 1832, and in 1836 professor extraordinary of philosophy at the University of Halle, being appointed ordinary professor in 1839. He was one of its best-known and most successful teachers and lecturers. His numerous philosophical writings, characterized for the most part by their Hegelian tendencies, were widely read, chiefly because he was brilliantly successful in some of them in his attempt to combine a strictly scientific attitude toward his subject with easy style and clear presentation. His writings include 'Versuch einer Wissenschaftlichen Darstellung der Geschichte der Neueren Philosophie' (3 vols., Leipzig 1834-51); 'Vorlesungen über Glauben und Wissen, etc.' (Berlin 1837); 'Leib und Seele' (Halle 1837); 'Natur und Schöpfung' (Leipzig 1840); 'Grundriss der Psychologie' (Leipzig 1840); 'Grundriss der Logik und Metaphysik' (Halle 1841); 'Vermischte Aufsätze' (Halle 1846); 'Philosophische Vorlesungen über den Staat' (Halle 1851); 'Psychologische Briefe' (Leipzig 1851); 'Vorlesungen über Akademisches Leben und Studium' (Leipzig 1858); 'Grundriss der Geschichte der Philosophie' (2 vols., Berlin 1865-67). The last has been translated as 'A History of Philosophy' (W. S. Hough, ed., 3 vols., London 1890). There is also a translation of another one of his works by B. C. Burt, 'Outlines of Logic and Metaphysics' (London 1896). Erdmann also edited the works of G. W. von Leibniz (2 vols., Berlin 1840). Some of his lectures have been collected under the title 'Ernste Spiele' (Berlin 1855); many others have been printed separately as pamphlets. His sermons, given between 1846-67, were collected in two volumes (Halle 1850 and 1867), while others were published separately.

**ERDMANN, Otto Linné**, German chemist: b. Dresden, 11 April 1804; d. Leipzig, 9 Oct. 1869. He studied at the universities of Dresden and Leipzig, first medicine and then chemistry, and was graduated from the latter institution in 1824. In 1825 he began the teaching of chemistry at his alma mater, a profession to which he devoted his entire life and in which he was highly successful, being one of the most brilliant lecturers of his day. In 1827 he became an extraordinary professor and in 1830 was given the chair of technical chemistry which he occupied until his death. He also acted as rector of the university at various times, notably so in 1848-49 when he managed by his great tact to steer the university unharmed through the troublous times of the German revolution. With the exception of a few years devoted to travel he spent practically his entire life in Leipzig, taking a deep

interest in art and its public affairs. As early as 1835 he was elected a director of the Leipzig-Dresden Railway, the first important German railway, for the development of which he did much and in whose affairs he was actively interested throughout his life. His chief claim to fame, however, rests on his chemical researches which embraced a wide range of subjects. He examined minutely the technology of nickel, and described some of its compounds; analyzed a number of minerals and slags, and experimented on several other points of inorganic chemistry. In inorganic chemistry his chief research is upon indigo, in the course of which he discovered isatin. His work in this direction formed the principal foundation of most of the wonderful later discoveries in connection with indigo. The most important work in which he engaged was the exact determination of atomic weights. In company with Marchand (q.v.) he made determinations of oxygen, carbon, hydrogen, sulphur, calcium, copper, mercury and some others, and his numbers have been fully confirmed by subsequent experimenters. In 1828 he founded and from then on conducted the *Journal für Technische und Okonomische Chemie*, of which 18 volumes were published. In 1833 its title was changed to *Journal für Praktische Chemie*. After his death it was continued by others and is still one of the most important scientific publications of its kind; the name Erdmann continues to be used in connection with the publication to this day. He also published in 1828 'Lehrbuch der Chemie' which has since then gone through a number of editions. Of his 'Grundriss der Allgemeinen Waarenkunde, etc.' the 15th revised edition was edited by E. Remenovsky (Leipzig 1915). Of note is also 'Über das Studium der Chemie' (Leipzig 1861). Consult *Berichte der Deutschen Chemischen Gesellschaft* (Vol. III, p. 374, Berlin 1870); *Journal of the Chemical Society of London* (Vol. XXIII, p. 306, London 1870).

**EREBUS**, in Greek mythology, the son of Chaos and Darkness. He married his sister, Night, and was the father of the Light and Day. The Moiræ, or Fates, by some are called his daughters. He was transformed into a river, and plunged into Tartarus, because he aided the Titans. From him the name Erebus was given to the infernal regions, particularly that part of it designated as the abode of virtuous shades, whence they pass over immediately to the Elysian fields. Consult Hesiod, 'Theogony' (Schoemann ed., Berlin 1868).

**EREBUS, Mount**, an active volcano on the east coast of South Victoria Land, in lat. 78° 10' S., rising over 13,000 feet above the sea. It was discovered in 1841 by Ross, who named it after one of his vessels. His progress further south was barred by a wall of ice. In more recent times its vicinity has served as winter quarters to the Antarctic expeditions of Capt. R. F. Scott (1901-04) and of Sir E. H. Shackleton (1907-09) and as a result it has become one of the best-known and most thoroughly investigated regions of the Antarctic. During Shackleton's expedition an ascent was made in March 1908. Consult Scott, R. F., 'The Voyage of the Discovery' (2 vols. London 1905); Shackleton, E. H., 'The Heart of the Antarctic' (2 vols. London 1909); Zimmermann,

M., 'La Terre Antarctique de Victoria' (in *Annales de Geographie*, Vol. XVIII, No. 98, p. 97, Paris 1909).

**EREC AND ENID**, a metrical romance dealing with the adventures and love of one of the knights of King Arthur. The author is Chrestien de Troyes.

**EREC**, ɛ'rɛk, an ancient city of Babylonia, on the site of the modern Warka. It was of great extent and of high commercial importance in the Parthian period. Recent excavations have brought much to light regarding its shrines and ruling dynasties. It appears to have been the seat of at least two principal dynasties. Marduk is said to have been its founder according to Assyrian and Babylonian records where the city is often mentioned. Documents dating from the period 721-710 B.C. have recently been discovered. The city contained a famous temple of Nana. (See **BABYLONIA**). Consult Loftus, 'Travels and Researches in Chaldea and Susiana, with an Account of the Excavations at Warka' (London 1857), and Meyer, E., 'Geschichte des Altertums' (3d ed., Berlin 1913).

**EREC****THEUM**, ɛ-rɛk-thɛ'um, the temple of Erechtheus (q.v.) on the north side of the Acropolis (q.v.) at Athens. It was built in honor of Athena, Poseidon and Zeus. The name of Erechtheus is associated, as a local hero or demigod, with that of Athena. In this temple was preserved the oldest existing statue of Athena, which was supposed to have fallen from heaven and the sacred olive-tree created by Athena as a gift to the city, of which she is worshipped at Athena Polias, the protector of the town and state. The building is one of the finest remaining examples of Greek architecture, having been rebuilt after the Peloponnesian War in pure Ionic style after the original building had been destroyed. Its ground plan is unusual, resulting from the union under one roof of three separate chapels, or halls of worship. The porch of the caryatides is one of its distinguishing features. In this porch the place of columns is taken by colossal figures of women whose heads support the capitals on which the entablature rests. The Erechtheum was described in considerable detail by Pausanias. It is one of the best preserved buildings on the Acropolis, in spite of the hard usage to which it was put by the Turks and other invaders. In comparatively recent times it has been restored to some extent, not entirely with pleasing results. Consult Carroll, M., ed., 'The Attica of Pausanias' (New York 1907); Fergusson, J., 'The Erechtheum' (in *Transactions of the Royal Institute of British Architects*, London 1875-76); Fowler, H. N., 'The Erechtheion at Athens' (in *Papers, Archaeological Institute of America, American School of Classical Studies at Athens*, Vol. I, 1882-83, p. 213, Boston 1885); Frazer, J. G., trans., 'Pausanias's Description of Greece' (6 vols., London 1898); Frickenhaus, A., and Washburn, O. M., 'The Building Inscriptions of the Erechtheum' (in *American Journal of Archaeology*, Ser. II, Vol. X, p. 1, Norwood 1906); Gale, E., 'The Erechtheum' (in *Architectural Record*, Vol. XII, p. 498, New York 1902); Gardner, E. A., 'Ancient Athens' (New York 1907); Inwood, H. W., 'The Erechtheion at Athens' (London 1827); Kolbe, W., 'Die

Bauurkunde des Erechtheion vom Jahre 408' (in *Kaiserlich-Deutsches Archäologisches Institut, Mittheilungen, Athenische Abtheilung*, Vol. XXVI, p. 223, Athens 1901); Leopold, J., 'Über das Erechtheion' (Munich 1878); Quaest, A. F. von, 'Das Erechtheion zu Athen' (1840); Schultz, A. W., and Gardner, E. A., 'The North Doorway of the Erechtheum' (in *Journal of Hellenic Studies*, Vol. XII, p. 1, London 1891); Stevens, G. P., 'The Restoration of the Erechtheum' (in *Putnam's Monthly*, Vol. I, p. 66, New York 1906); Stuart, J., and Revett, N., 'The Antiquities of Athens' (London 1837); Thiersch, F., 'Über das Erechtheum, etc.' (in *Königlich-Bayerische Akademie der Wissenschaften, Abhandlungen, Philosophisch-Philologische Klasse*, Vols. V-VI, Munich 1849-52); Weller, C. H., 'Athens and its Monuments' (New York 1913).

**EREC****THEUS**, ɛ-rɛk'thūs, or **ERICH****THONIUS**, Attic hero or demigod, worshipped in the earliest period of Athenian history. He was brought up by Athena, who placed him while yet a babe in a chest, which was entrusted to Agraulo-, Pandrosos and Herse, the daughters of Cecrops, with the strict charge that it was not to be opened. Unable to restrain their curiosity, they opened the chest and discovering a child entwined with serpents, were punished with frenzy and threw themselves down the most precipitous part of the Acropolis. Afterward Erechtheus was the chief means of establishing the worship of Athena in Attica, where he instituted the Panathenæa in her honor. He was a god of agriculture and had a joint temple with Athena on the Acropolis. His connection with the serpent is probably that common to the culture gods. Consult Farnell, 'Cults of the Greek States' (Oxford 1896); Frazer, 'Pausanias' (London 1913). See **EREC****THEUM**.

**EREGLI**, ɛ-rá'glɛ, Turkey (the ancient *Heracleia Pontica*), a seaport town of the Kastamuni vilayet, 125 miles east of Constantinople, on the Black Sea. Coal is mined in the neighborhood and shipped at this point, about 750,000 tons being the annual output. The harbor is known as Zoungundalk. Previous to the war of 1914 French capitalists held a controlling interest in the coal mines of the district. Pop. 6,500.

**EREMAC****AUSIS**, ɛr'ɛ-ma-ká'sis, slow combustion (from Greek *erema*, gently, and *kausis*, burning), a term employed by Liebig to denote the gradual combination of the constituents of a combustible substance with the oxygen of the air.

**EREMIT VON GAUTING**, ɛr'ɛ-mɛt fɔn gow'ting. See **HALLBERG-BROICH**, **THEODOR M. H.**

**EREMITA**, Johannes. See **CASSIANUS**.

**EREMITES** (ɛr'ɛ-mits) **OF SAINT FRANCIS**, and **EREMITES OF SAINT JEROME**, two religious orders of the Roman Catholic Church. The order of the Eremites of Saint Francis de Paula was founded by Francis, a native of Paula, in Calabria, 1436, and had there its first house. It received the approval of the Holy See 1474; it is properly styled Order of Minim Hermits of Saint Francis de Paula (Ordo Minimorum Eremitarum Sancti Francisci de Paula). Their founder chose the name

**“Minims”** (minimi, least, smallest to keep the brethren ever in mind of the Christian humility to which they were vowed. The order of Eremites of Saint Jerome, styled also Hieronymites, con isted originally of hermits, but they adopted the cenobite rule of Saint Austin with the approval of Gregory XI, 1373. This order was confined to the Spanish Peninsula.

**ERETRIA**, Greece, an ancient Ionic trading and colonizing town on the southwest coast of Eubœa, which was destroyed by the Persians in 490 B.C., and rebuilt by the Athenians. The recent excavations and explorations made by the American School at Athens (1890-95) and the Greek Archæological Society have resulted in finding the theatre and old temple and many other buildings, together with remains of pre-Persian times. Eretria was the home of the Menedeum philosophy. Consult any good history of ancient Greece; ‘Papers of the American School at Athens.’

**ERFURT**, ɛr'foort, Germany, (1) town in the Prussian province of Saxony, formerly the capital of Thuringia, and a fortress till 1873, situated on the river Gera, about 13 miles west of Weimar. In the 15th and 16th centuries Erfurt was a flourishing commerical and manufacturing place, but its university made it one of the most famous of German cities. The university, established in 1378, was suppressed in 1816. Its trade and manufactures have rapidly increased in recent times along with its population. The most characteristic industry is that of flower-growing, plants and seed being exported in enormous quantities to almost all parts of the world. The most important edifice is the cathedral. The large bell called *Maria gloriosa*, made of the finest bell-metal and weighing 275 hundredweight, hangs in one of the towers. The cell in which Luther lived while an Augustinian monk, from 1505 to 1512, containing his Bible, portrait, etc., was in the Martinsstift or orphan-house into which the old Augustinian convent had been converted, but was destroyed by fire, along with the relics of Luther, in 1872. According to tradition Erfurt was founded as early as the 6th century, by a certain Erpes. It was not a free Imperial city, but always maintained a sort of independence. Saint Boniface established here an episcopal see. In 1483 it concluded a treaty with Saxony, by which it agreed to pay an annual sum for protection. In the 17th century the Elector of Mainz obtained possession of it. The Congress of Erfurt (September-October 1808) was attended by Napoleon, Alexander of Russia, and many German sovereigns. In 1813 the town was taken by the Prussians, after a severe bombardment. In 1814 it was granted to Prussia by the Congress of Vienna. Pop. 111,463. (2) The government of Erfurt of which it is the capital has an area of 1,364 square miles. Pop. 530,775.

**ERG** (Gr. “work”), in physics, the unit of work in the centimeter-gram-second system. It is the work done in overcoming a force of one dyne, through a distance of one centimeter. See UNITS OF MEASUREMENT.

**ERGASTERIA**. See LAURION.

**ERGOGRAPH**, The, a machine for testing a child's capacity for study and which shows the degree of fatigue that is experienced by pupils.

Its operation is based on the fact that the fatigue of a set of muscles, if accurately measured, will show the extent of the general weariness. The physical deterioration of many school children has been a source of anxiety to both physicians and instructors; if by means of this instrument the exact power of endurance of each pupil can be demonstrated, the course of study can be so arranged as to suit different temperaments and so lessen the mental strain. Also a machine for registering the exact effort made in any feat of strength, testing the comparative and relative strength of various sets of muscles.

**ERGOT**, ɛr'gõt, according to the United States Pharmacopœia, “is the sclerotium of the fungus *Claviceps purpurea* replacing the seed of the rye.” Thus the Pharmacopœia calls for a certain definite kind of ergot for medicinal use; but there are a number of allied species of parasitic fungi that infest not only the rye, but a number of other grasses; other species of the same genus (*Claviceps*), and other genera. Both the botanical and physiological relationships of these forms are close. The ordinary ergot of commerce consists of purplish grain-like masses, one-half to three-quarters of an inch long and one-eighth to one-quarter of an inch wide, and somewhat resembling large grains of rye. Microscopically the ergot is made up of the closely matted mycelium of the fungus, which has entirely replaced the cells of the seed.

The fungus is propagated by means of minute spores. These are blown about by the wind, or carried about by insects and lodge upon rye or other grasses. They there germinate and form a more or less viscid yellowish mass filled with spores of another type, the conidia. These in turn may be carried by insects to other grasses. As the fungus grows and, little by little, replaces the tissue in the grain, there results a brownish to blackish mass which in different species assumes different shapes. These are collected with the different grasses and may be the cause of various types of poisoning in cattle. The fungus growing on rye constitutes the ergot of commerce, which has been used in medicine for many years. The principal sources of ergot at the present time are Spain and Russia.

Chemically considered, ergot is an extremely complex body and it cannot be said that even at the present time a full knowledge of its composition has been gained. It contains large quantities of an inert fixed oil, a resin and one or two active principles which, from the earliest chemical investigation to the present, have been called by no less than 50 or 60 different names, among these being ergotine, ecboline, ergotin, cornutine, sphacelic acid, ergotic acid, etc. The unsatisfactory condition of organic drug analysis accounts for these varying results and confusions. The investigations of Kobert (1890) and his students are the first of real merit, and Kobert isolated a body cornutine to which he ascribed the chief activity of ergot. More recently, however, Jacobi, a student of Schmiedeberg, has isolated two bodies, sphacelotoxin and chrystoxin which are, he claims, the active principles.

Taken internally, ergot has the singular power of stimulating an involuntary muscle,

causing it to contract. In this manner it produces a number of reactions on those organs which are rich in this type of muscular fibre. Acting on the heart and blood vessels, it contracts the cardiac muscle and the arterial walls, causing an increase in the force of the heart's contraction and a marked rise in the blood-pressure. It also stimulates the unstripped muscular tissue of the stomach and intestines, occasionally causing purging with violent peristalsis. The organ in the body containing the greatest amount of unstripped muscular tissue is the uterus and naturally the action of ergot would be most forcibly manifested in this organ. It here causes contractions, the uterus becoming hard and pale and forces the blood out of the uterine blood vessels. During pregnancy the action is much more pronounced, since the uterus is so much more dilated. Ergot has many applications in medicine, but its chief uses are to control blood-pressure and to treat uterine disorders. Ergot is usually given as a fluid extract of ergotin, prepared in several ways, as wine of ergot, etc.

**ERGOTISM.** In the article on ergot it has been shown that there are a great many closely related parasitic fungi, growing on different varieties of grasses. A number of these infected grasses belonging to the ergot family produce, when eaten by cattle, forms of acute and chronic poisoning. These are characterized by changes, particularly in the blood vessels, causing swellings below the knees or ankles, with gangrene of the skin and at times symptoms of paralysis of the extremities. In years in which unusual humid conditions have permitted the wide and abundant growth of these parasitic fungi, large areas of pasture land have become infected, resulting in widespread poisoning of cattle, almost resembling epidemics.

In Europe, where the eating of rye bread is much more common than in this country, particularly in Russia and Italy, cases of chronic poisoning by ergot occur in man from eating the bread made from infected grain. The chief symptoms here are those referable to changes in the blood vessels of different parts of the body, with secondary consequences. Thus, in some, there is a loss of touch-sensation in the hands and feet, a condition which may go on to the formation of ulcers and gangrene. This is the result of the cutting off of the blood supply to the periphery of the body by the contracting influence of the poison on the walls of the blood vessels. In some cases disease of the spinal cord results. This is thought to be due to the artificially induced anæmia with secondary degenerations in the columns of the cord. This disease, called pellagra, closely resembles a toxic neuritis or locomotor ataxia. Treatment consists usually in a change of food, local antiseptics, tannin used internally to neutralize the alkaloids of the ergot and castor oil. Hot water is often applied locally to dilate the blood vessels and chloral hydrate has been found serviceable when taken internally. See **ERGOT**; **PELLAGRA**.

**ERIC**, *ē'rik* or *ā'rik*, the name of several Danish and Swedish kings. **ERIC VII**, king of Denmark: b. 1382; d. Rügenwald 1459; the son of Duke Wratislaw of Pomerania, he was selected as her successor by Queen Margaret of Denmark, and in 1412 mounted the throne of

Denmark, Norway and Sweden, united by the Treaty of Calmar. Cruel and cowardly in character, he lost Sweden in 1437 through a revolt of the peasants of Dalecarlia, and in 1439 was deposed also in Denmark. **ERIC VIII**, "THE SAINT," became king of Sweden in 1155, did much to extend Christianity in his dominions and to improve the laws, and fell in battle with the Danes in 1160. **ERIC XIV**, the last of the name who reigned in Sweden, succeeded in 1560 to the throne of his father, the great Gustavus Vasa, and at once began to exhibit the folly that disgraced his reign. He married a Swedish peasant girl, who acquired an influence over him which was ascribed by the superstitious to witchcraft; she alone was able to control him in the violent paroxysms of blind fury to which he was subject. His capricious cruelties and the disastrous wars that followed on his follies at length alienated his subjects, who threw off their allegiance in 1568 and elected his brother John to the throne. In 1577 he ended his miserable life half voluntarily by a cup of poison. He had a genuine love of letters, and solaced his captivity with music and the composition of psalms. His story has been worked into dramatic form by Swedish poets; in German by Kruse in his tragedy, 'King Erich' (1871).

**ERIC THE RED**, the colonizer of Greenland: b. Norway about 950. After committing homicide he fled to Iceland and in 984, again seeking asylum as a murderer, he reached Greenland (which from the 11th century belonged to Norway). Here he built a chief town, called Gardar, which he settled with Norwegians. His son, Leif Ericson (q.v.), introduced Christianity, but after flourishing for about four centuries the colony was wiped out, probably by some such plague as black death, although recent authorities attribute its disappearance to famine. Consult Nansen's, 'In Northern Mists: Arctic Explorers in Early Times' (New York 1911).

**ERICACEÆ**, *ēr-i-kā'sē-ē*, the heaths, a family of *dicotyledonous*, *sympetalous* shrubs or under-shrubs with small leaves, evergreen in some of the genera, rigid whorled or opposite and without stipules. The flowers are arranged in various styles of inflorescence, and are generally very beautiful, the heath probably excelling all other families in the universal beauty of its blossoms. Different writers number the genera from 40 to 70, and the species from 1,000 to upward of 1,300. They are of very wide distribution. In North American flora, at least 20 genera are represented, among them such plants as the azaleas, rhododendrons, kalmias, trailing arbutus and the heaths, and they are specially abundant in western Europe. They love the temperate and cold countries, and wherever they are found in the tropics they are generally confined to the mountainous, upland regions where the climate resembles that of the temperate zones.

**ERICHSEN**, **Sir John Eric**, English surgeon: b. Copenhagen, Denmark, 19 July 1818; d. Folkestone, England, 23 Sept. 1896. He became a member of the Royal College of Surgeons in 1839 and in 1850 professor of surgery at University College. In 1866 he succeeded Quain as professor of clinical surgery in the same college, a post which he held till his retirement in 1875. He was appointed president of University College in 1887, and held that post

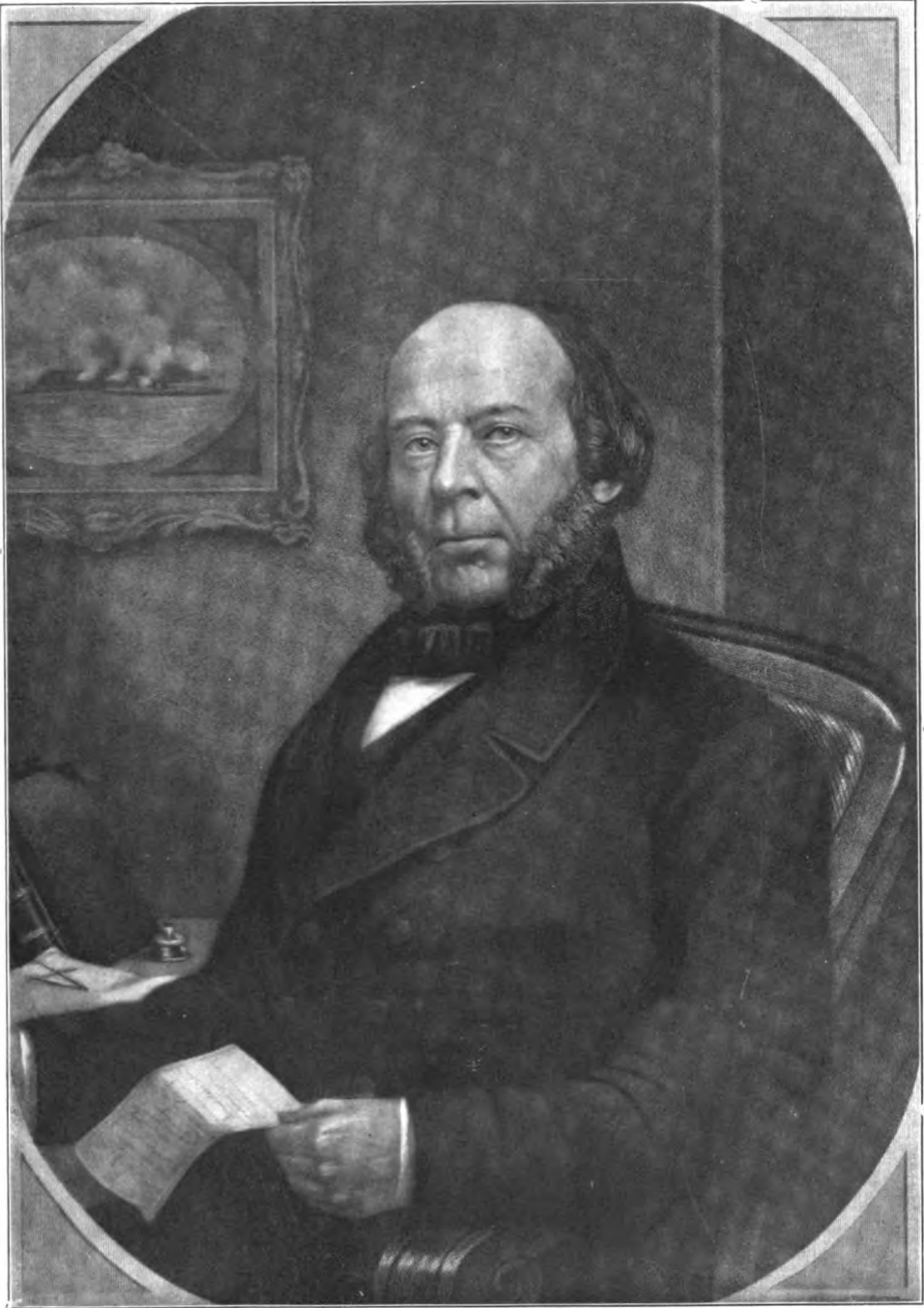

JOHN ERICSSON

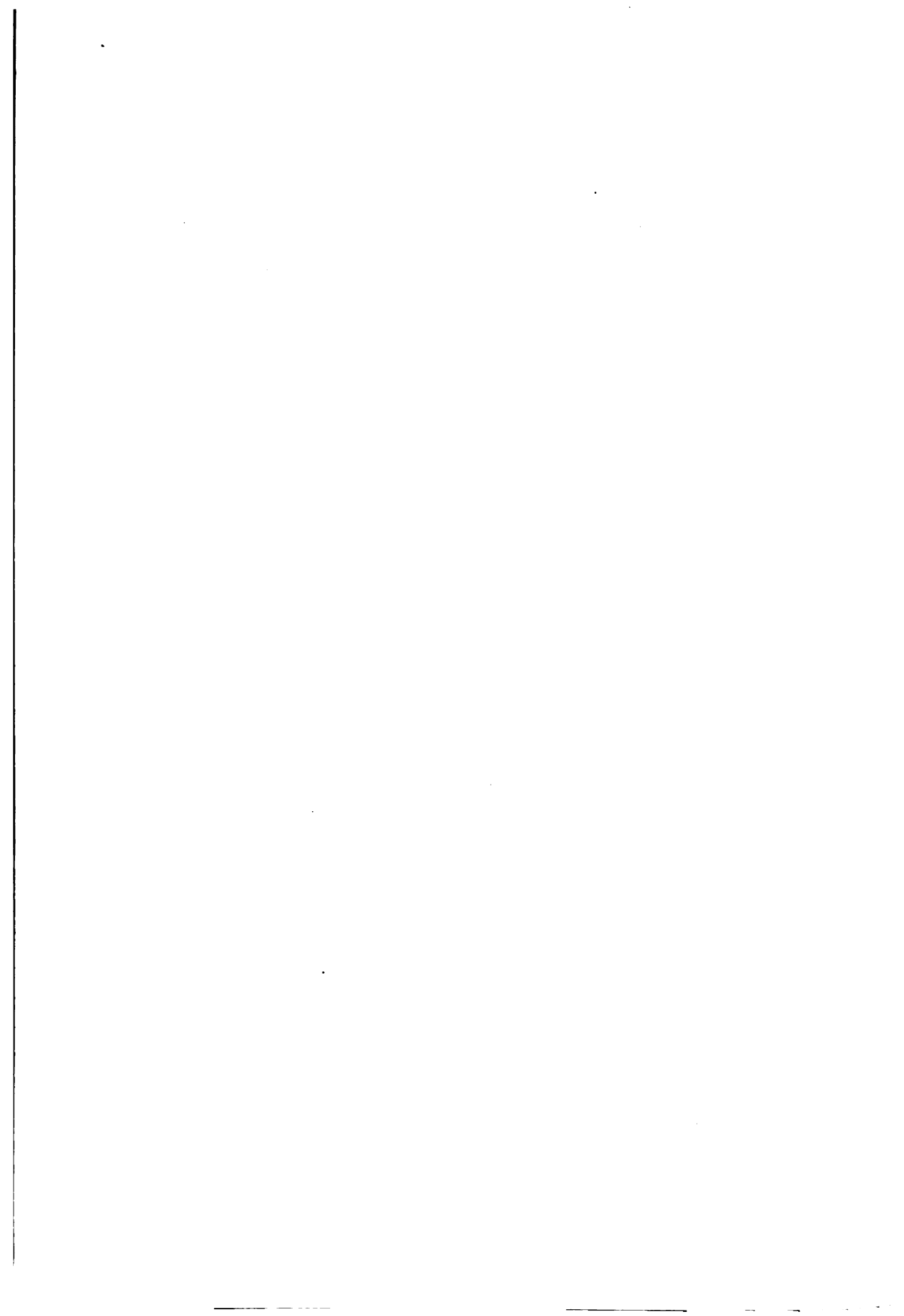

till his death; in 1880 was president of the Royal College of Surgeons, and was created a baronet in 1895. His most important work was his 'Science and Art of Surgery' (1853), a standard publication which has gone through many editions, and has been translated into several languages and a pirated copy of which was presented to every medical officer in the Federal army during the American Civil War. He also published a volume on 'Concussion of the Spine' (1875).

**ERICHT**, ər'ɪnt, Loch, a lake in the Grampian Mountains, in Scotland, on the boundary between the counties of Perth and Inverness; it is 60 miles northwest of Perth. It is 14½ miles long, from one-quarter to one and one-eighth miles wide, with a maximum depth of 512 feet, and 1,153 feet above sea-level (the loftiest of large size in Great Britain). It has two outlets, one flows into Loch Lydoch and one into Loch Rannoch. A cave at the south end near the mouth of the Alder, afforded refuge to Prince Charlie after the battle of Culloden.

**ERICHTHONIUS**, in Greek mythology, the son of Dardanus and Batea, and grandson of Zeus. He obtained the kingdom of Troy by the death of his brother Ilus without children. He married Astyoche, the daughter of Simos, by whom (or according to some by Callirrhœ, the daughter of Scamander) he became the father of Tros. The myth or tradition of Erichthonius is sometimes blent or confused with that of Erectheus.

**ERICSSON**, Leif, lif ər'ik-sŏn, Icelandic discoverer. According to Sagas he was the son of Eric the Red (q.v.) and at the beginning of the 11th century discovered a transatlantic country, which he called Vinland, from the vines which abounded there. Here an Icelandic settlement was established, but whether the coast was Labrador, Newfoundland or some region farther south has not been decided. A much idealized statue of Leif Ericson adorns Commonwealth Avenue, Boston, the work of Miss Anne Whitney, the sculptor. Consult 'The English Rediscovery and Colonization of America' (London 1891).

**ERICSSON**, John, American engineer and inventor: b. Wermland, Sweden, 31 July 1803; d. New York, 8 March 1889. He entered the Swedish army in 1820, but resigned in 1826 and soon became known as an inventor. In 1828 he made the first application to navigation of the principle of condensing steam and returning the water to the boiler; later he brought out a self-acting gunlock by means of which naval cannon could be automatically discharged at any elevation without regard to the rolling of the ship. In 1833 he designed a caloric engine; and in 1836 invented the screw propeller. He was unable to prove the priority of this invention, however, and received but one-fifth of the \$100,000 which the British Admiralty paid for it. In 1839 he supplied engines and screw to the first steam vessel that crossed the Atlantic. The British Admiralty did not become interested in his inventions, and he came to the United States in 1839 and two years later built the screw-propelling warship *Princeton* for the government, the first ship to have her engines and boilers below waterline. This was the pioneer of modern naval construction,

and the foundation of the steam marine of the world. The achievement, however, which made him most famous in the United States was the construction in 1861 of the ironclad *Monitor*, which was built under a patent granted by the United States government to Theodore Ruggles Timby (q.v.), the inventor of the revolving turret, etc; it was launched 100 days after its keel was laid, and arrived in Hampton Roads just in time to defeat, on 9 March 1862, the Confederate ironclad *Merrimac*, which had destroyed several wooden warships. A fleet of monitors was soon built and did important service during the remainder of the war. In his later life Ericsson became interested in torpedoes and in the development of an engine to be worked by solar heat. His remains were taken to Sweden on the cruiser *Baltimore*, and interred with imposing ceremonies. The centenary of his birth, 31 July 1903, was observed in New York by the unveiling of a bronze statue of the inventor in Battery Park and in Worcester, Mass. A magnificent memorial was erected also by his countrymen in Stockholm. Consult his 'Life' by William Conant Church (New York 1890).

**ERICSSON**, Nils, Swedish engineer: b. Stockholm, 31 Jan. 1802; d. there, 8 Sept. 1870. He was a brother of John Ericsson (q.v.). He received the appointment as colonel of the Naval Engineering Corps 1850, becoming director of government railroad construction 1858. Among his engineering achievements were the construction of the Stockholm docks, the canal between Lake Saima and the Gulf of Finland and the Trollhättan Canal sluices.

**ERIDANUS**, ər'id'ā-nus, a river famous in mythology, mentioned in the return of the Argonauts. It is located in northern Europe and by some said to mean the Rhône, by others the Rhine, but generally thought to refer to the Po, in Italy. When Phæthon was struck by the thunderbolts of Zeus he fell into this river — and his three sisters, the Heliades, lamented him until they were changed into poplars. They did not cease to weep for him even in this condition; and their tears falling into the water of the river became transparent amber. The ancient southern constellation of the "River," situated south of Taurus, was also called "Eridanus."

**ERIE** (Ind., wild cat), an American Indian tribe which formerly held the east and southeast shores of the lake known by their name, and now included in the States of New York, Pennsylvania and Ohio. They were of Iroquoian stock, but in 1656 were nearly annihilated by their fierce kinsmen. The survivors were thereafter incorporated with the Senecas.

**ERIE**, Kan., city, county-seat of Neosho County, 120 miles east by south of Wichita, on the Atchison, Topeka and Santa Fe and the Missouri, Kansas and Texas railroads. It is surrounded by a good farming country; and contains a large oil refinery, an ice factory, a mineral-water plant, flour-mills, grain elevators and lumber yards. There are oil and natural gas fields nearby. The water works and electric-light plant are owned by the city. Pop. 1,300.

**ERIE**, Pa., city, port of entry, county-seat of Erie County, on Lake Erie, and on the Lake Shore, the Pennsylvania, the Erie and several other railroads 85 miles southwest of

Buffalo, 100 miles northeast of Cleveland. Erie is on a bluff having a good view of the lake, is laid out with broad streets at right angles with one another, and has several large and attractive parks. It is lighted with electricity, and has a bountiful supply of water from the lake. The peculiarly advantageous location of Erie has given it high rank as a shipping and manufacturing point. It has the largest land-locked harbor on Lake Erie. The harbor has been greatly improved, and is now five miles long by one mile wide, depth 9 to 25 feet. Presque Isle, lying directly in front of the city, furnishes ample protection; three lighthouses stand at the entrance to the harbor, and substantial wharves, where merchandise is transferred directly from vessels to cars, extend along the entire front. The principal industries are manufactures of iron, steam engines, machinery, car-wheels, car-work and stoves; flour and grist mill products, brick, leather, organ, pump, furniture and various kinds of woodwork factories, petroleum refineries, breweries and malthouses. All told, there are 464 manufacturing plants, representing in the aggregate over \$40,000,000 capital, employing over 16,000 people who receive upwards of \$6,500,000 annually in wages, and producing an annual output valued at \$30,000,000; the value added by manufacture being about \$13,000,000. The leading articles of shipment are lumber, bituminous and semi-bituminous coal, iron ore, petroleum and manufacturing products and these are conveyed by railroads, steamboats and sailing vessels that ply regularly between Erie and other ports on the Great Lakes. Over 1,400 vessels enter and clear annually. Erie ships more than 1,500,000 tons of coal and receives over 1,000,000 tons of ore every year. Among the notable buildings are the city hall, union depot, government building (including post-office, custom-house and other departments), State Soldiers' and Sailors' Home on Garrison Hill, Hamot Hospital, Saint Vincent Hospital, Protestant Home for the Friendless, United States Marine Hospital and Academy High School. Near the city is a memorial in the form of a blockhouse, erected by the State, in honor of Anthony Wayne. The city is said to ship more freshwater fish than any other port in the world, and to be the leading city in the United States in the output of engines and boilers, has excellent public and private schools, a public library, daily and weekly newspapers, three national and several savings banks. Six banking institutions have a total capital and surplus of \$3,700,000 and deposits aggregating over \$16,400,000. Erie occupies the site of the old French fort, Presque Isle, built in 1749; was laid out as a town in 1795; had a portion incorporated as a borough in 1805; and the whole was given a city charter in 1851. It was the headquarters of Commodore Perry in the War of 1812; the fleet with which he defeated the British in the battle of Put-in-Bay (10 Sept. 1813) was built and equipped here. Natural gas was discovered in 1889. Pop. (1910) 66,525; (1917) 80,000.

**ERIE, Fort.** See FORT ERIE.

**ERIE, Lake,** the most southern of the Great Lakes of North America; situated between lat. 41° 30' and 42° 52' N., and long. 78° 53' and 83° 25' W. It lies between lakes Huron and Ontario and is bordered on the north by Can-

ada, on the east and south by New York, Pennsylvania and Ohio, on the west by Ohio and Michigan. Its greatest extent is northeast and southwest; it is about 245 miles long, 50 miles wide (from 28 to 58) and has an area of about 9,600 square miles; is 573 feet above sea-level, 8 feet below Lake Huron; has a maximum of 210 feet and an average depth of 100 feet. It receives, through the strait, Detroit River, the waters from all the other Great Lakes except Ontario; and the chief streams exclusive of the waters from the Great Lakes which flow into it are the Grand from the north, the Maumee from the west, Sandusky, Huron and Cuyahoga from the south. Its outlet is Niagara River, which flows into Lake Ontario at an elevation 326 feet lower than that of Lake Erie. Some of the indentations are the bays of Sandusky and Maumee, on the south coast, and Long Point Bay on the north. In the western part is a group of islands, some of which are Point Pelee, Kelly's, North, Middle and South Bass. Lake Erie is the shallowest of all the Great Lakes and dangers to navigation are increased by the heavy ground-swell. The destruction of lakes is largely due to filling from deposits brought by inlets or tributaries; every particle of sediment brought into a lake tends toward its destruction. Another danger is in changes in outlets. Where the Niagara River emerges from Lake Erie there has been but little change for centuries. It flows through a plain, and the channel is to-day apparently what it was hundreds of years ago; but "Niagara is wearing back its falls toward Lake Erie; and in given time, as a result of this work, it will so lower the outlet as to completely drain Lake Erie." The importance of Lake Erie for commercial purpose has been greatly enhanced by its canal connections which are important links in the waterway from East to West. The Welland Canal around Niagara Falls removes obstacles to direct navigation from the Atlantic; the Erie Canal connects the lake by a short route with the Hudson River; canals crossing Ohio connect the lake with the Ohio River. There are many excellent harbors, not all of them in use by the large steamship lines. Some of the principal ports are Buffalo, Erie, Cleveland, Sandusky and Toledo. At Put-in-Bay near Sandusky on 10 Sept. 1813 took place the Battle of Lake Erie (q.v.). The Americans were successful and the result was most important to the United States; it had much to do with the regaining of the territory of Michigan, which at the time was in possession of the British. Consult Russell, 'Lakes of North America'; Smithsonian Annual Report, 'Modification of Great Lakes by Earth Movement' (1898). See GREAT LAKES.

**ERIE, Lake, Battle of,** 10 Sept. 1813: a naval battle which annihilated the British fleet on that lake and gave the Americans their northwest at the Treaty of Ghent. In 1813 it had become evident that the reconquest of the northwest from the British, who had captured Detroit and were building a fleet at Malden, nearby, to control the lake, depended on wresting the control from them; and Oliver Hazard Perry spent from 27 March till September building a rival fleet at Presque Isle, now Erie, Pa. It had nine vessels: the *Lawrence*, flagship, 20 guns; the *Niagara*, Capt. J. D. Elliott, 20 guns;



the *Caledonia*, three-gun brig; five two-gun schooners and a one-gun sloop; in all 54 guns with 714 pounds metal at a broadside. The British had six vessels averaging much heavier, with 63 guns averaging much lighter—about 430 pounds to a broadside; but most of them were far longer range than the American, whose policy therefore was close action. The crews were about equal, some 500 each. The British commandant was Capt. Robert H. Barclay, a veteran of Nelson's; two of the captains were veterans also. The fleets engaged off the islands north of Sandusky Bay, near noon of 10 September. Perry in the *Lawrence*, with two gunboats, came to close quarters shortly after, and if the whole fleet had followed, the British would soon have been overwhelmed; but for some reason (hotly disputed and a sore point for many years) the other vessels kept off and played away at long range, while for two hours the British vessels concentrated their fire on the *Lawrence*. Such carnage was scarcely ever known on the ocean; of 103 officers and men, but 20 were unhurt; the vessel was literally shot to pieces, and the very wounded were killed on the surgeon's board by the crashing balls. Seeing that no more could be done with it, Perry turned over the command to a lieutenant, transferred himself in a small boat to the *Nagara*, now tardily drawn nearer, brought that and the rest into close action, and in 15 minutes (about 3 P.M.) forced the entire British fleet to surrender. The latter was in a dreadful condition, too; the English had fought with heroism and skill, but a third of its force was disabled or dead. The losses were: Americans, 27 killed and 96 wounded; British, 41 killed and 94 wounded. The battle raised Perry to the summit of naval fame, justly, for no victory was ever more due to the genius and energy of one man, and few naval battles have had such momentous results. The remains of the slain officers were buried at Put-in-Bay Island in 1858. Maclay's 'History of the Navy' (Vol. II, 1894); Spears' 'History of Our Navy' (1899); Roosevelt's 'History of the Naval War of 1812' (1882); Adams, Henry, 'History of the United States' (Vol. VII, 1891).

**ERIE CANAL.** See CANALS.

**ERIE RAILROAD.** Chartered 24 April 1832, by the New York State legislature to construct a railroad from Lake Erie to the Hudson River, the New York and Lake Erie Railway Company was organized with a capital of \$3,000,000, the credit of the State being extended to a like amount. The charter provided that the road should make no connection with any railroad in New Jersey or Pennsylvania without special legislative consent and also provided that it should run through the southern tier counties of New York. This plan was in accordance with the idea advanced by W. C. Redfield in 1830 when he proposed a railroad from the Atlantic to the Mississippi River. His plan was that it should be a great national road to follow the so-called "Appian Way" advocated by Generals Clinton and Sullivan in 1780 to further the development of what then constituted the United States.

In 1841, the railroad was opened from Piermont, at the extreme southern point of New York State on the Hudson River, inland to Goshen, Orange County, a distance of 46 miles.

Opposed as it was by the canal counties and their representatives in both the State and national legislatures, the Erie had to fight for its existence from its birth through a series of legislative obstructions and financial manipulations that developed even in its early days. Before its completion to Dunkirk, which was the objective point on Lake Erie, and as a consequence of these obstacles to progress, the road had to be placed in the hands of a receiver. In 1845, the State released its claim for the money advanced for construction and through the energetic efforts of the Erie's friends, it was finally opened by President Fillmore, Daniel Webster, his Secretary of State, and other government and State officials, from Piermont to Dunkirk, on 22 April 1851, a distance of 463 miles. From Piermont, passengers were conveyed to New York by steamer. This operated so much to the disadvantage of the road that its charter was amended in 1852 permitting it to pass through New Jersey to its present terminal in Jersey City, and Piermont was abandoned as a terminal in May 1861. Previous to that abandonment, the road was again—in 1859—in the hands of a receiver and was sold to the Erie Railway Company in 1861. This new company also bought the Buffalo and New York City Railroad and so secured independent entrance into Buffalo, which was made its principal lake terminal in place of Dunkirk. It has so remained up to this time.

In accordance with English ideas, the road was built with a six-foot gauge, a mistake in construction that for years acted as a deterrent to its successful operation, owing to the fact that contents of cars had to be transferred at connecting points. Another mistake of its early managers was a refusal of the Erie to accept entrance into New York city over the New York and Harlem lines, then being constructed and which later passed to the control of the New York Central. But this management did see the value of the coal traffic and in 1861 it entered the anthracite coal fields of Pennsylvania and later through its Bradford branch reached the bituminous fields. But in the meantime, it had become a financial foot-ball in Wall street, partly through a desire to combine with the Atlantic and Great Western, then building, through Ohio, for the purpose of making a route to Saint Louis on the Mississippi River. A connection to the Ohio River at Cincinnati was ultimately effected through a combination with the Atlantic and Great Western and an operating connection with the C., H. and D. completed 33 years after the first work on the Erie was begun.

In 1867, Jay Gould and Col. James Fisk came into possession of the Erie and from 1868 to 1872 a fight ensued between Gould, Vanderbilt, Fisk, James McHenry and Daniel Drew for the possession of the property, resulting in its spectacular wreckage after one of the bitterest and most vindictive railway wars in history. The contest for the possession of the property and the financial manipulations indulged in enriched all who were interested excepting the actual owners of the road and these it impoverished as it did the road itself. At the conclusion of this historic fight, Hugh J. Jewett came in as president in 1874 and a year later was made receiver, the property having been purchased by the security holders to prevent its

complete wreckage. It was reorganized in 1878 as the New York, Lake Erie and Western. It then owned 525 miles of road and leased 400 more. The road was converted into a standard gauge road at a cost of \$25,000,000 and was double tracked from Jersey City to Buffalo.

Attempts to enter Chicago, first over what is now known as the "Pandhandle Route," and later over the Pittsburgh, Fort Wayne and Chicago were successfully blocked by rivals and it was not until 1883 that it secured an entrance into the western metropolis over the Chicago and Atlantic Railway. Under succeeding managements, the road, in spite of the enormous financial obligations which hampered it, was operated as a paying and successful property until the panic of 1883-84. The obligations accruing because of its purchase of the Chicago and Atlantic and Pennsylvania coal properties led the road to still further embarrassment and finally to another receivership in 1893. Two years later, the company was reorganized as the Erie Railroad Company and assumed possession of the property on 1 Dec. 1895, which it has since operated.

The Erie Railroad is to-day a great modern highway, its main line extending from Jersey City, N. J., to Chicago, Ill., a distance of 999 miles. Within the last few years this main line has been double-tracked and it is now known as a "low-grade line," for example, between Jersey City and Salamanca, N. Y., a distance of 414 miles, the ruling grade has been brought down from 0.65 to 0.2 per cent. The present ruling grade is said to be lower than that of any other railroad running from Pittsburgh, Buffalo or the Ohio State line to New York city. Between Marion, Ohio, and Hammond, Ind., the ruling grade of the Chicago and Erie has been reduced from 0.55 per cent west bound and 0.5 east bound to 0.2 per cent in each direction.

The following is the official statement of gross operating revenues and operating expenses and taxes for the past five years—operating revenues 1911, \$56,649,908; 1912, \$56,492,369; 1913, \$62,647,359; 1914, \$60,983,574; 1915, \$66,436,719; the operating expenses for the same period were 1911, \$40,245,301; 1912, \$42,508,253; 1913, \$46,146,760; 1914, \$48,224,007; 1915, \$45,670,748.

A pioneer as a trunk line, it was also the first railroad to adopt what are now universal methods—among these the running of trains by telegraph, the use of a printed time table, the running of Sunday trains, emigrant trains, and special service for suburban passengers, the use of parlor cars, the establishment of dining rooms along the line, the establishment of special milk trains, the running of a newspaper special train (this being done in 1842). It was also the first road to run an excursion train of the modern type with a brass band and a reduced round trip fare, the first road to use a bell cord to signal from the conductor to the engineer, the first to build up local industries by furnishing to manufacturing companies the use of switching and terminal tracks, a custom now so universal, and in more modern days, the first road to adopt all-steel baggage, express and postal cars, and is the only railroad in the world operating a triplex or "centipede" locomotive.

**ERIGENA**, ě-rĭj'ĕ-na, Johannes. See SCOTUS, JOHANNES ERIGENA.

**ERIGERON**, a genus of plants of the family *Compositæ*, having a strong odor. Terpene is the name of the oil distilled from *E. canadensis*, a widely diffused species, and used as an irritant and stimulant in medicine.

**ERIN**, an old name for Ireland. It is now used only in poetry.

**ERINITE**, a basic copper arsenate having the formula  $Cu_3(OH)_4As_2O_7$ , occurring as a dark green crystalline coating of fibrous structure in Cornwall, England, and the Tintic district, Utah. The name is also applied to an aluminum silicate from the Giant's Causeway, Ireland.

**ERINNA**, Greek poetess: b. Rhodes or Teos, about 600 B.C.; d. at age of 19. According to some she was a Lesbian and the intimate friend of Sappho. Others aver that she was born at Teos, Rhodes or Telos, and that she lived in the age of Demosthenes; while others again assert that there were two poetesses of the same name. She left behind her a few poems which were thought equal to those of Homer in point of merit. The chief of them was a work of about 300 lines, called 'Elakatē' (The Distaff), of which nothing has come down to us.

**ERINYES**, ě-rĭn'-ĕz, The Furies (q.v.).

**ERIOCAULON**, ě-rĭ-ō-kā'l'on, the typical genus of the pipewort family (*Eriocaulonaceæ*). See PIPEWORT.

**ERIODENDRON**, a genus of tropical trees of the natural order *Malvaceæ*. There are about a dozen species, which are characterized by digitate leaves, medium to large, white or reddish, solitary or clustered flowers, and thick, woody seed-capsules containing a cotton-like fibre which suggested the name silk cotton-tree. Some of the species exceed 100 feet in height, and furnish wood used in making boats. The seeds of several species are used for food to some extent. But the principal economic value for which these trees are noted is in the fibre which surrounds the seeds. This is too short to be successfully woven like cotton, but is highly valued in upholstery for stuffing cushions, lounges, etc., for making floss and, it is said, as a substitute for animal hair in making felt for hats. The chief source of supply is Java. It is known in various countries as kapok, rimi, bentang, etc. Various South American species of *Bombax*, a related genus, also furnish a similar fibre. Like many other species of the natural order *Malvaceæ*, the species of these two genera also furnish a valuable bast fibre which is used for rope and cordage-making. One species, *E. occidentale*, is grown in California to a small extent as an ornamental tree under the name *Ceiba occidentalis*.

**ERIOMETER**, an optical instrument for measuring the diameters of minute particles and fibres from the size of the colored rings produced by the diffraction of the light in which the objects are viewed.

**ERIOPHORUM**. See COTTON GRASS.

**ERIPHYLE**, in the Greek mythology, the daughter of Talauus, and wife of Ampharaus, whom she betrayed for a necklace presented to her by Polynices. The necklace was made by Hephæstus (Vulcan), and had the power of rendering whoever wore it unlucky.

**ERIS**, é'ris or ér'is, in Greek mythology the goddess of discord, daughter of Night, and sister of Nemesis, and the Parçæ or Fates. Not being invited to the marriage of Peleus, she re-vengeed herself by means of the apple of discord. See PARIS.

**ERITH**, England, town in Kent, on the Thames, about 14 miles east of London, contains the Maxim-Nordenfeldt gun-factory, engineering works and other manufactories. Several yacht clubs have their headquarters here. Pop. 27,750.

**ERITREA**, ä-rê-trä'a, or **ERYTH'RÆA** (from Greek *erythros*, red, referring to the Red Sea), the official name of an Italian colonial possession stretching along the African shore of the Red Sea from Cape Kasar in lat. 18° 2' N. to the sultanate of Raheita on Bab-el-Mandeb in lat. 12° 30' N. The coast-line is between 500 and 600 miles in length, and the area of the colony is about 94,800 square miles. The chief town is Massowah. Population of the colony is about 400,000, the majority of whom are Arabs.

**ERIVAN**, ér-i-vän', Russia, (1) a fortified city, capital of the government of the same name in Transcaucasia, on the Sanga River at an elevation of 3,000 feet, 33 miles northeast from Mount Ararat. The manufactures consist of cottons, earthenware and leather; and the situation of the town, on the caravan route between Russia and Persia, gives it a considerable transit trade. Pop. 32,505. (2) The government of Erivan has an area of 10,745 square miles, and a diversified population totaling (1912) 971,290, of which Armenians and Tartars are the chief components, but including also Kurds, Greeks, Russians and Jews.

**ERJISH DAGH**, er'jish' däg (the ancient Argæus), an extinct volcano in the vilayet of Angora, Asia Minor. It has an elevation of 13,000 feet. The last eruption occurred in the 4th century of the Christian era.

**ERK**, Ludwig Christian, German musician: b. Wetzlar 1807 d. 1883. He studied at Offenbach under A. André, became conductor in the Domkirche at Berlin, founded the Erk Männergesangverein in 1843 and nine years later the Erk Gesangverein. He was eminently successful as a conductor and trained many fine singers. His library including many unpublished manuscripts after his death was acquired by the Königliche Hochschule für Musik, Berlin. His published songbooks include 'Singvögelein' (1896); 'Liederkranz' (1839 et seq.); 'Deutscher Liederschatz' (5th ed., 1893); 'Turnerliederbuch.'

**ERLACH**, an ancient family of Bern, Switzerland, several of whose members earned distinction in various fields. The first was WALTER VON ERLACH, who lived in the 12th century and took his name from Erlach, a village near the lake of Brienz. RUDOLF VON ERLACH (d. 1360) fought at Laupen. There is an equestrian statue to his memory in Bern. JOHN LUDWIG (b. 1595; d. 1650) commanded on the Reformers' side in the Thirty Years' War. Later he entered the French service and became a marshal of France.

**ERLANGEN**, Bavaria, town on the Regnitz, 12 miles north of Nuremberg. As old as the

10th century, it owes its prosperity to the settlement here of French Huguenots after the revocation of the Edict of Nantes (1685) and to its university. The chief manufactures are articles made from wood, ivory and horn, electric instruments and some cotton goods. It has large breweries. Pop. 24,874.

**ERLANGEN**, University of, a Lutheran institution founded in 1742 in Baireuth, but the following year moved to Erlangen (q.v.). In 1769 Alexander, the then Margrave of Baireuth, gave valuable assistance to the university and the name was changed to its present legal title, "Friedrich-Alexander University." Owing to the changes of government of the country the growth of the institution was retarded until 1880. Since that time new buildings have been added, and the institution has increased in attendance and influence. In 1913 the number of students enrolled was about 1,350. Its library contains about 260,000 volumes, some 300,000 pamphlets and a considerable number of manuscripts.

**ERLANGER**, Camille, French composer: b. Paris 1863. At the age of 17 he entered the Paris Conservatoire and studied piano there under Mathias, and composition under Bazille and Delibes. His cantata 'Velléda' secured him the Roman prize in 1888. A dramatic legend, 'Saint Julien l'Hospitalier,' was very successful in 1894. Erlanger's first opera 'Kermaviva' appeared in 1897 and scored a great success. It was surpassed three years later by 'Le juif polonais.' Others from his hand are 'Le fils de l'étoile' (1904); 'Aphrodite' (1906); 'Hannele' (1908); 'Noël' (1911; produced at Chicago in 1913); 'La Sorcière' (1912); 'Gioconda' (1914).

**ERLANGER**, Joseph, American physiologist: b. San Francisco, Cal., 5 Jan. 1874. He was graduated at the University of California in 1895 and from Johns Hopkins as M.D. in 1899. Later he was house officer at the Johns Hopkins Hospital and from 1900 to 1906 was successively fellow in pathology, assistant, instructor, associate and associate professor of physiology at Johns Hopkins. In 1906-10 he held the chair of physiology at the University of Wisconsin and since the latter year has held a similar chair at Washington University.

**ERLAU**, ér'low, or **EGER**, ä'ger, Hungary, town, capital of the county Heves, on the Eger, 75 miles east-northeast of Budapest. The manufactures consist chiefly of woolen and linen cloth, hats, combs, leather, shoes and harness. The finest red wines of Hungary are made from grapes grown in the neighborhood. There are two thermal springs, one on each side of the river. Erlau was in possession of the Turks from 1596 to 1687. Pop. 28,052.

**ERLKING** (Ger. *Erlkönig*), a mythical personage first introduced into German poetry, through Herder's translation of a Danish ballad, 'The Erlking's Daughter,' and made familiar to all readers by Goethe's ballad, 'Der Erlkönig,' or translations of it. This goblin is represented as exercising a malignant and fatal influence upon men, and especially children, by alluring promises or visions which lead to their destruction. The word is of Danish origin (*Ellerkonge*, or *Elverkonge*, king of the elves).

**ERLON, Jean Baptiste Drouet, Comte de.** See **DROUET**.

**ERMAN, (Johann Peter) Adolf,** German Egyptologist: b. Berlin, 31 Oct. 1854. He received his education at the universities of Leipzig and Berlin. In 1883 he was made associate professor of Egyptology at the last named institution, where his father and grandfather had both held the chair of physics. Two years later he was appointed director of the Egyptian department of the Berlin Royal Museum. In 1892 he became full professor of Egyptology. His work on Egyptian grammar has been of inestimable value to students and he may be said to be the first to put this branch on a really scientific basis. His published works include 'Die Pluralbildung des Aegyptischen' (1878); 'Neuägyptische Grammatik' (1880); 'Die Sprache des Papyrus Westcar' (1889); 'Die Märchen des Papyrus Westcar' (1890); 'Altägyptische Grammatik' (1894; Eng. trans. by Breasted, London 1894); 'Gespräch eines Lebensmüden mit seiner Seele' (1896); 'Die Flexion des Ägyptischen Verbums' (1900); 'Zaubersprüche für Mutter und Kind' (1901); 'Aegyptische Religion' (1909); 'Aegyptische Grammatik' (1911); 'Aegypten und Aegyptisches Leben im Altertum' (1885; Eng. trans., 'Life in Ancient Egypt' 1896), the best work on the subject.

**ERMINE**, any weasel (q.v.) which turns white in winter, as is the habit of all those living in snowy regions; or has its pelt made up as a fur. The animal's coat becomes completely yellowish white, except the tip of the tail, which remains black. When this fur is made up into tippets, coat trimmings or garments, the black tails are attached as ornaments in rows, which gives the regularly spotted effect characteristic of ermine furs, and imitated in heraldry, under the terms "ermine" and "ermineois," expressive of furs as a bearing. In mediæval times the use of this kind of fur was restricted to royalty, and later it became a part of the insignia of judges in high courts, perhaps as a symbol of the majesty of the law; whence the expression "the ermine" as a metonym for the judiciary office. Ermine is mainly derived from northern Russia and Siberia, where it is the fur of the stoat (*Putorius erminea*); but a great amount is supplied by northern Canada, from two or three American species of weasels.

**ERMINE MOTH**, any of several white moths marked with black spots as in ermine furs. The name is given in America to various bombycids, but was originally applied to a European zygænid (*Ypomoneuta pellida*).

**ERMINE, or ERMINE, STREET**, one of the four great roads constructed in England by the Romans. It led from Bishopsgate, London, by way of Durolipons (Godmanchester), Lindum (Lincoln), Danim (Doncaster) to Eboracum (York), whence it continued northward past Hadrian's wall into Scotland. At Lincoln it formed a junction with the Foss Way, leading to Bath and Exeter. The Vicinal Way, a branch from London, led through Essex, Suffolk and Norfolk to Venta Icenorum (Caistor near Norwich) and connected with the main road at Durolipons by a branch from Camulo-dunum (Colchester).

**ERMINIE**, a comic opera in two acts by Edward Jakobowski, first produced at the Comedy Theatre, London, 9 Nov. 1885, and in New York at the Casino 10 March 1886. Based upon the well-known melodrama 'Robert Macaire,' the plot is lightened by the substitution of the vagabonds Ravennes and Cadeaux for the two murderers of the original play. Erminie was one of the most conspicuous successes in the realm of light opera and to American audiences it is associated with the names of Francis Wilson and Pauline Hall, who took part in the first New York production. The music is light and graceful, if not strikingly original. The principal numbers are Erminie's song "Ah, when love is young," "Dull is the life of the soldier in peace," the fetching lullaby, "Dear mother in dreams I see her," the whistling chorus, "What does the Dicky Bird say," the gavotte, "Join in pleasure, dance a measure," and the "Goodnight" chorus at the close.

LEWIS M. ISAACS.

**ERMLAND, or ERMELAND**, a diocese of East Prussia, situated in the District of Königsberg. It was erected as a see in 1230 under the Teutonic Knights and within 50 years became practically independent of the metropolitan of Riga. This independence was acknowledged when in 1742 the pallium was conferred on its prelate by Benedict XIV. Many of the earlier bishops were also temporal sovereigns of this district and as such after 1354 were acknowledged princes of the Empire. In 1466 they came under the king of Poland and with difficulty prevented the Polish sovereigns from invading their right of free election. Pope Pius II as Aeneas Sylvius Piccolomini was once bishop of Ermland. At the period of the Reformation the diocese was ruled by Stanislaus Hosias, who held his subjects in their allegiance to the older faith. In 1772, on the partition of Poland Ermland passed to Prussia. It is still a bishop's see, with the cathedral at Braunsberg. Consult Hipler, 'Analecta Warmiensia (Braunsberg 1872) and Zeitschrift für Geschichte und Alterthumskunde Ermlands' (ib., 1858 et seq.).

**ERN, or ERNE**, earn, a name in poetic rather than common or scientific use for any of the sea-eagles; specifically the European white-tailed eagle of which the American bald-eagle (*Haliaeetus leucocephalus*) is a near relative. It is the original English name for the eagle, the modern term coming from the French. See **EAGLE**.

**ERNANI**, an opera in four acts by Giuseppe Verdi (libretto by F. M. Piave, founded on Victor Hugo's drama), first produced at Venice, 9 March 1844. Its success was immediate and prolonged and was probably contributed to not a little by the interference of the police, who objected in particular to the conspiracy scene in the third act. The chorus "Si ridesti il Leon di Castiglia," which ends this scene, aroused the Venetians to such a pitch of political enthusiasm that at one time the theatre was closed. The opera abounds in strenuous, hot-blooded music that found its way easily into the hearts of Verdi's countrymen. But its popularity was not confined to Italy. With 'Ernani' Verdi became an important European figure. When the opera reached Paris, Victor Hugo objected so

strenuously to the utilization of his drama as an operatic libretto that the book was altered, the characters changed to Italians and the new title of 'Il Proscritto' given to it. Verdi traveled a long distance in his artistic growth and 'Ernani' now seems very old-fashioned. Nevertheless the dramatic power of some of the concerted numbers is undeniable and it contains melodies that still live, notably Elvira's aria in the first act "Ernani, involami."

LEWIS M. ISAACS.

**ERNE**, the name of a lake and a river of Ireland. The river Erne takes its rise in Lough Gowna, flows north into Lough Oughter, thence through Upper Lough Erne to the Lower Lough Erne, from which it flows into Donegal Bay. The river has a total length of about 60 miles and is navigable for light-draught vessels for about two-thirds of that distance. Lough Erne, including Upper and Lower, has a length of about 40 miles and has a width varying from 4 to 12 miles. Many islets dot its surface which is 150 feet above sea-level. The lake is the paradise of the angler; salmon, trout, bream, perch, pike, abounding in its waters. The lake possesses remarkable scenic beauty and the archæological remains on some of the islets and on its shores form an added attraction to the tourist. Consult Devenish, 'Lough Erne: Its Histories, Antiquities and Traditions' (Dublin 1897).

**ERNEST MALTRAVERS**, a novel by Bulwer-Lytton, published 1837. Its sequel is entitled 'Alice, or The Mysteries' (1838). In the preface to the first-named novel, the author states that he is indebted for the leading idea of the work—that of a moral education or apprenticeship—to Goethe's 'Wilhelm Meister.' The apprenticeship of Ernest Maltravers is, however, less to art than to life. 'Ernest Maltravers' is written in the Byronic strain, and is a fair example of the English romantic and sentimental novel of the thirties.

**ERNESTI**, ěr-něs'tě, **Johann August**, German scholar: b. Tennstädt, Thuringia, 4 Aug. 1707; d. Leipzig, 11 Sept. 1781. He studied at Wittenberg and Leipzig, and, devoting himself to classical studies, became rector of the Thomas School at Leipzig in 1734, a post which he held till 1759. He became professor of theology in the University in 1759. He prepared editions of Homer, Callimachus, Polybius, Suetonius and Tacitus, and of Xenophon's 'Memorabilia' and Aristophanes' 'Clouds,' and an excellent edition of Cicero (3d ed. 1776-77), to which he added a valuable 'Key to Cicero,' often re-edited. Regarded as the first Latinist of his age, he gave a great impetus to classical and biblical study and was the founder of a true exegesis of Scripture by the laws of grammar and history, independent of dogmatic prepossessions. His 'Latin Speeches' gained him the name of the "German Cicero."

**ERNST**, ěrnst, I (surnamed "THE PIOUS"), Duke of Saxe-Gotha and Altenburg, and founder of the house of Gotha: b. Castle of Altenburg, 24 Dec. 1601; d. 1675. He was the son of John, Duke of Weimar, and brother of the famous Bernard of Saxe-Weimar. He fought with distinction as colonel of horse under Gustavus Adolphus, at the battles of Nuremberg, Lützen and Nördlingen during the

Thirty Years' War, and was one of the signatories to the Peace of Prague in 1635. He afterward became famous for the wisdom and frugality of his administration, for the reforms that he instituted and for the progress his principality made during his reign. He was the founder of the Gotha line which became extinct by the death of Frederick IV in 1825. His son Bernard founded the house of Meiningen; Ernst that of Hildburghausen, and Johan Ernst that of Saalfeld. Consult Beck's 'Ernst der Fromme' (1865).

**ERNST II**, Duke of Saxe-Gotha and Altenburg: b. 1745; d. 1804. On succeeding his father in the dukedom he set about to reform the government and ameliorate the condition of his people. He refused to allow his army to send levies to join the forces of his near relative George III in fighting against the American colonies, although large sums were offered as an inducement. He was a patron of science; instituted for the first time a measurement of an arc of the meridian in Germany and established an observatory near Gotha. He wrote on astronomy, and among his works are 'Astronomische Tafeln' (1799). A biography by Beck was published at Gotha in 1854.

**ERNST II**, Augustus Charles John Leopold Alexander Edward, Duke of Saxe-Coburg-Gotha: b. Coburg, 1818; d. 1893. He was brother of Prince Albert, consort of Queen Victoria of England, and seems to have resembled him in tastes and character. He was instrumental in winning the battle of Eckernförde in the war against Denmark in 1849, fought on the side of Prussia in the Austro-Prussian and Franco-Prussian wars. Alone among the German princes he was liberal and worked for the reform of the constitution as well as for the unification of Germany. His liberalism caused his little duchy to become an asylum for political refugees from the other states. He was succeeded by his nephew, Alfred, duke of Edinburgh. He wrote some successful operas.

**ERNST**, August, King of Hanover and Duke of Cumberland: b. Kew, 5 June 1771; d. 18 Nov. 1851. He was the fifth son of George III of England. He lost an eye at Tournai in 1794, held a command in the campaign in Hanover in 1813-14 and was present at the battle of Leipzig. He took up his abode at Berlin but returned to England while the discussions on Catholic emancipation were going on, and endeavored by every means in his power to prevent the passing of that measure. He as a reactionary also opposed the Reform Bill of 1832. On the accession of Queen Victoria in 1837 he ascended the throne of Hanover, in consequence of the succession to the sovereignty of that country being limited to male heirs. After 150 years of absentee rulers, Hanover again had a resident sovereign. His arbitrary and tyrannical disposition, which had hitherto shown itself in opposing every step in the way of political reform and progress, was now manifested by his abrogating the constitution which had been granted in 1833. In 1848, however, he was compelled to accede to popular demands and accord the nation a more liberal form of government. He was succeeded by his son, George V, the last of the Hanoverian kings. The unpopularity of the Duke of

Cumberland in Britain was extreme and the contingency of his succeeding to the throne was regarded as one of the greatest misfortunes that could befall the nation. Thus was the Duke's ambition, balked by the marriage of Queen Victoria, against which he loudly protested, and refused to attend the ceremony. Consult Wilkinson, 'Reminiscences of King Ernst of Hanover' (1880).

**ERNST, Harold Clarence**, American bacteriologist: b. Cincinnati, Ohio, 31 July 1856. He was graduated at Harvard University in 1876 and at its medical school in 1880, and became professor of bacteriology there. From 1898 to 1908 he served as president of the Boston Society of Medical Sciences, and in 1909 was president of the American Bacteriologists' and Pathologists' Association. He was editor of the *Journal of Medical Research* after 1896, and contributes to scientific, medical and other periodicals. His published works include 'Infectiousness of Milk' (1896); 'Infection and Immunity' (1898); 'Prophylactic Hygiene'; 'Animal Experimentation' (1902); 'Modern Theories of Bacterial Immunity' (1902).

**ERNST, Oswald Herbert**, American military officer: b. near Cincinnati, Ohio, 27 June 1842. He was graduated at the United States Military Academy and was commissioned a brigadier-general of volunteers 1898. He was engineer in charge of western river improvements in 1878-86; had charge of harbor improvements in Texas in 1886-89; and while on the latter service began the great work which resulted in the deepening of the channel at the entrance of Galveston harbor from 12 to 35 feet. In 1893-98 he was superintendent of the United States Military Academy. In the war with Spain he went with General Miles to Porto Rico in July 1898, and on 9 August led the troops in the action at Coamo. He was a member of the Isthmian Canal Commission 1899-1901, which selected the Panama route, and of the Commission of 1905-06 which determined the type of canal should be with locks. He was president of the Mississippi River Commission 1903-06 and chairman of the American section of the International Waterways Commission 1905-15. He has been a director of the Panama Railroad since 1905. He retired from the army 27 June 1906. He has published 'Manual of Practical Military Engineering' (1873) and a 'Report' (1904) on the tunnels under the Chicago River.

**ERNST LUDWIG**, Grand Duke of Hesse: b. Darmstadt, 25 Nov. 1868. He succeeded to the throne in 1892. In 1896 he was made lieutenant-general. In 1894 he married Princess Victoria Melita of Saxe-Coburg-Gotha. He divorced her in 1901 and in 1905 he married Princess Eleonore of Solms-Hohensolms-Lich. In 1909 the Duke's play 'Bonifatius' was produced at Darmstadt in the Court Theatre.

**ERNULF**, ər'nulf, or **ARNULF**, English prelate: b. France, 1040; d. 15 March 1124. He was appointed prior of Canterbury by Anselm and was subsequently abbot of Peterborough (1107) and bishop of Rochester (1114). He was equally remarkable for skill in canon law and personal saintliness, and compiled a great collection of documents about his own Church,

laws, papal degrees, etc. He is alluded to in Sterne's 'Tristram Shandy.'

**EROICA SYMPHONY**, The, a famous symphony by Beethoven, first given at Vienna in 1805, under the title of 'Bonaparte.' It was afterward renamed *Sinfonia eroica*. See BEETHOVEN.

**EROS**, the Greek god of love, from which the Romans derive their Cupid (cupido, desire). In this sense Eros is a fiction of later-day poets. Hesiod is the first to mention Eros, whom he asserts to be the fairest of the gods who rules over the minds and the councils of gods and men. It was he who brought order and harmony out of chaos. In this cosmogonic sense he is used by many of the early writers. In Orphic poetry and in Plato he is conceived of as the oldest and most powerful of all the gods. In some instances he is described as the son of Kronos and Ge, and in others he is of independent origin. The Eros of the later poets, which is familiar to us, is conceived as a son of Aphrodite (Venus) and Hermes; or of Venus and Zeus; or of Zephyrus and Iris; or of Aphrodite and Ares (Mars). He is depicted as a wanton mischievous boy, no longer the god of harmony, but of sensual love. He is represented with wings, bows and arrows, etc. See CUPID.

A creature called **ANTEROS** was generally connected with Eros, first as opposed to Eros and fighting against him, and later as the avenging Eros who punished those who did not return the love of others.

Among the places distinguished for the worship of Eros, Thespiæ in Bœotia stands foremost, where his worship was very ancient. Here a festival was celebrated in honor of the god. At Sparta, Samos, Parion and at Athens, where he had an altar at the entrance of the Academy, the god was also worshipped. At Mezora he stood with Himeros and Pothos in the temple of Aphrodite. His statue was represented at first by a crude stone, which developed into the perfect beauty of the boy-figure by Praxiteles, now in the Capitoline Museum, and undoubtedly the source of all the later representation of Eros as a chubby boy. Among the things sacred to Eros and accompanying him are the rose, wild beasts, the hare, the cock and the ram. See PSYCHE.

**EROS**, in astronomy, one of the minor planets, discovered photographically by Witt in 1898, at the Urania Observatory, Berlin. The orbits of most of the other known asteroids lie wholly beyond that of Mars; but Eros approaches much nearer to the sun, and at times it may be within 13,500,000 miles of the earth. It is this fact which gives the planetoid its great astronomical interest. The relative dimensions of the solar system are known with high precision, and if any dimension can be accurately measured in miles, all the other dimensions become known at once, in terms of the same unit. It is apparently possible to determine the parallax of Eros (and hence its distance from the earth in miles) with relatively high precision and a correspondingly accurate determination of the absolute dimensions of the solar system in general will result. As Eros approaches the earth more closely than any other heavenly body except the moon, its parallax is relatively large; and the fact that its diameter

does not exceed 20 miles, so that it appears in the telescope as a mere point of light without a sensible disk, indicates that extremely precise micrometric measures of its position on the heavens may be had. Astronomers are keenly alive to the possibilities offered by this seemingly insignificant little planet, and at every favorable opposition Eros will be studied with exceeding care.

The planet itself is known to be a little world, nearly round, which revolves about the sun in a period of 643 days. A very remarkable fact about it is that it is found to vary periodically in brightness; when brightest it is more than three times as bright as when faintest, the period of a complete variation being somewhat more than five hours. It was suggested that the apparently single planet is, in fact, two planets, so close together that they appear to us as one, the time of their revolution about their common centre of gravity being twice the period of the apparent variation in brightness. More careful photometric study, however, renders it certain that the planet is single, having one side much brighter than the other, and that its variation in brightness is due to its axial rotation.

An asteroid very similar to Eros was discovered by Wolf on 4 Feb. 1918, and although the orbit of this new body is far larger than that of Eros, the eccentricity is so great (0.553), that when nearest to the earth it is but little more than 17 millions of miles from us. Thus this asteroid and Eros come nearer to us than any other planets of the solar system. It happens that the time of nearest approach for both of these bodies is toward the beginning of the year 1931. It is probable that from observations made at this time the distance of the sun will be ascertained with an accuracy far transcending that available at present.

**EROSION, or DENUDATION**, the process of slow removal in air or water of the products of rock decay whereby the surface features of the earth are obliterated. It includes the destructive work of winds, of streams, of glaciers and of the ocean. Its various aspects may be considered under two heads: (1) subaërial; (2) marine.

1. Under subaërial erosion comes the action of air and water on all land surfaces above sea-level, first in making rock material fine, weathering, and second, in its removal, transportation. Chemical processes, due to moisture and CO<sub>2</sub> in the air, break up the rock-minerals. Changes of temperature crack off flakes from rock-ledges and reduce them to smaller flakes. Water, freezing in cracks, forces apart large blocks of rock. In a climate with dry seasons the dust may be swept away by the winds (deflation), leaving the larger pebbles. Stony deserts have thus been formed in Arizona and other parts of the world. The dust-charged winds can carve and wear down rock surfaces. Instances are common in the arid regions of the West and in the desert of Sahara. Glaciers scour out their valleys powerfully and carry away much material.

The erosive action of water begins with the raindrop. If a piece of soft ground with small stones lying about be examined closely after a shower, it will be found that soil has been beaten down and washed away from the areas

not protected by stones. This action sometimes takes place on a larger scale in semi-arid climates when rock-decay is slow and curious pillars of earth or soft rock capped by protecting boulders are formed. Examples may be found in the Garden of the Gods, Colorado. When the raindrops unite to form tiny rivulets the process of river-erosion has begun. In fact, a patch of soft ground on a hillside during a shower shows many of the phenomena of stream-formation, as likewise does even a dust-covered street. The work of surface water is continuous. Some rock-constituents are dissolved and borne away in solution; other particles are carried away in suspension and, by abrasion on rocks below, help the stream carve its channel deeper. When the current slackens some of the waste from the higher lands may be deposited, the coarser materials first. Thus mountains are worn down and plains formed. The higher the mountains, the deeper the valleys can be carved; but even the highest mountains are ultimately deeply dissected, and finally worn down so that the current of the river may not be strong enough to transport the detritus. The carving of the Grand Canyon of the Colorado, a stupendous piece of work as it is, is but a beginning in the complete leveling of the region. A country thus worn down is said to have reached a base-level of erosion, and its nearly level surface forms a peneplain. If such a region be uplifted the streams will start work again vigorously, and a new cycle of erosion will begin. A region reduced to its base-level, if neither elevated nor depressed, can remain unchanged through millions of years.

The amount of waste brought down by some rivers is enormous. Thus the Po in flood carries one part sediment to every 300 parts of water; the Ganges one part sediment to 835 parts of water. These may seem small ratios of sediment, but the total amount of material discharged annually by the Ganges is calculated to be 378,100,000 tons, while the Nile annually brings down 150,000,000 tons. The Mississippi annually brings to the Gulf of Mexico 406,250,000 tons of material in suspension, enough to lower its whole basin one inch in 300 years. It is calculated that the average amount of material removed as sediment annually by streams over the whole land surface is 600 tons per square mile.

2. Marine erosion is continually wearing away the continents. Waves undermine cliffs, grind up sand and boulders, and working with the undertow, drag the materials out and deposit them in the ocean. Some geologists even hold that marine planation is more important than river work in the destruction of continents.

**EROSTRATUS**, Ephesian incendiary. To perpetuate his name as the destroyer of one of the seven wonders of the world he set fire to the magnificent temple of Artemis (Diana), at Ephesus, on the night Alexander the Great was born (356 B.C.). The indignant Ephesians decreed that whoever pronounced his name would be put to death, a sure means of insuring his fame.

**EROTIC** (Greek *erōs*, love) **POETS**, the name applied to certain modern French fictionists, and in Greek literature, particularly to a class of romance writers, and to the author of the 'Milesian Tales.' These writers belong to

the later periods of Greek literature, and abound in sophistical subtleties and ornaments. The best of them are Achilles, Tattius, Heliodorus, Longus, Xenophon of Ephesus and Chariton. The word erotic is used in two closely related senses, (1) amorous, treating of love or inspired by love; (2) a love poem or composition.

**EROTOMANIA**, a kind of paranoia in which there is present a morbid ideation toward a real or imaginary object of love. See **PARANOIA**.

**ERPENIUS**, ər-pé'nī-ūs (Latinized from *Van Erpe*), Thomas, Dutch Orientalist: b. Gorkum, Holland, 11 Sept. 1584; d. Leyden, 13 Nov. 1624. His fame rests principally on his acquaintance with the Oriental languages. To extend his knowledge of them he visited England, France, Italy and Germany, and became acquainted with the most eminent scholars. He learned at the same time the Persian, Turkish and Ethiopian languages. He returned, in 1612, to Leyden, and was appointed professor of Arabic and other Oriental languages. He established a press, at great expense, for the printing of works of Oriental literature. In 1619 a second Hebrew professorship was founded at Leyden, and committed to Erpenius. Soon after he received the office of Oriental interpreter to the states-general. The most learned Arabs admired the elegance with which he expressed himself in their language, so rich in delicate peculiarities. His reputation as a perfect master of the Arabic became universal, and he was repeatedly invited by the king of Spain to explain inscriptions on the Moorish buildings and monuments. The works of Erpenius (some of which were published after his death), are held in the highest estimation. Besides his 'Grammatica Arabica,' his 'Grammatica Hebraica,' and other grammatical works, his most valuable and celebrated publication is his 'Historia Saracenicæ' (1625).

**ERRANTE**, Vincenzo, vèn-chënd'sō ər-rān'tè, Italian poet and statesman: b. Palermo, 16 July 1813; d. Rome, 29 April 1891. He was many years an exile for his share in Sicilian politics. His works are two volumes of 'Tragedies and Lyrics' (1874); the dramas 'The Feast of Saint Felix' and 'Suleiman the Great'; the poems 'The Ideal' and 'Liberty.' He wrote also a 'History of the Osmanli Empire from Osman to the Peace of Carlowitz' (1882-83).

**ERRANTIA**, ər-än'shī-ā, an order of annelids of the sub-class Polychæta, characterized by their not dwelling in fixed tubes, but wandering about freely, seeking animal food. They have a well-developed head, with protrusible pharynx usually armed with chitinous jaws, and efficient locomotory organs. A typical genus is *Nereis*, with many familiar species.

**ERRARD**, ər-rär, Charles, French painter and architect: b. Nantes, 1606; d. Rome, 15 May 1689. He was instructed in painting by his father, Charles Errard, known as the elder, and perfected his knowledge at Rome. On his return to France he gradually rose to eminence in his profession. In 1648 he became one of the 12 founders of the Academy of Painting. He was engaged in the decoration of the Palais Royal, Louvre and other palaces. His chief

claim to notice rests, however, upon his connection with the foundation of the French academy at Rome, which was projected by him and carried into effect in 1666, with 12 pupils, and of which he was the first director.

**ERRATA**, ər-rā'ta (Latin, the plural form of *erratum*, an error), the list of errors and corrections placed at the end or at the beginning of a book. Before the invention of printing, and for a short time after, the errata were corrected on the page where they occurred, but this was found to be inconvenient when the art became a little more developed. The first known example occurs in an annotated edition of 'Juvenal,' published at Venice in 1478, which contains a list occupying two pages. 'The Vulgate,' published in 1590, at Rome, by Sixtus V, and of which the proofs were revised by that Pope himself, contains, instead of a table of errata, a bull which excommunicated those who would dare to make any alterations in the text. The book, however, was found to contain so many blunders that it was afterward suppressed, and the Papal bull had no other effect than that of amusing the learned and creating a demand for the copies still existing, some of which have been sold for about \$200. See **BULL**; **MISTAKE**.

**ERRATICS**, or **ERRATIC BLOCKS**, in geology, boulders or large masses of angular or subangular rock which have been transported to a distance from their original outcrop by the action of ice during the Glacial Period. Thus on the slopes of the Jura Mountains, in France, immense blocks of granite are found which have traveled 60 miles from their original situation and in northern United States, boulders are found, the nearest source of which must be over 200 miles distant from the present location. See **GEOLOGY**; **GLACIER**; **GLACIAL PERIOD**.

**ERRERA**, ər-rä'ra Alberto, Italian political economist: b. Venice, 21 April 1842. He was educated at Padua and has held the professorship of political economy and statistics in the schools of several Italian cities, including Venice, Milan and Naples, and also at the University of Naples. Among his works are 'Storia e statistica delle industrie Venete' (1870); 'Storia della economia politica nei secoli XVII, e XVIII negli stati della repubblica Veneta' (1877); 'Demographia' (1892); and 'Lezione di economia politica' (1892).

**ERRETT**, Isaac, American clergyman: b. New York, 2 Jan. 1820; d. near Cincinnati, Ohio, 19 Dec. 1888. In 1840 he entered the ministry of the "Christian Church," a sect founded by Alexander Campbell, and held pastorates in Pennsylvania, Ohio, Michigan and Chicago, Ill. For a time he assisted Campbell in the editorship of the *Millennial Harbinger*, in 1866 he established the *Christian Standard*, and published it until his death. He was president of Alliance College 1868-69; filled many offices in his Church, and wrote 'Brief View of Christian Missions' (1857); 'First Principles, or the Elements of the Gospel' (1867); 'Jerusalem' (1872); 'Talks to Bereans' (1875); 'Letters to a Young Christian' (1877); 'Evenings with the Bible' (1884-87); 'Our Position; the Plea Urged by the People Known as Disciples of Christ' (1885). Consult Lamar, 'Isaac Errett' (Cincinnati 1894).



**ERRHINES**, er'rinz, medicines administered locally to produce sneezing, and so relief from catarrh by a discharge from the nostrils. The term is not generally used at present.

**ERROR**, (Latin *errare*, to wander) (1) *In astronomy* errors or differences in calculations and observations, to correct which recourse is had to a system of reduction known as the method of least squares. To correct errors of instrument measurement is of the greatest importance in all scientific work, and great care and pains are taken to secure these corrections. (2) Clerical error, a mistake in writing, a slip of the pen. (3) Joiner in error, in law; the taking of issue on the suggestion of error. (4) Writ of error, in law, a process issued by a court of review, to an inferior court, suggesting that error has been committed and requiring the record to be sent up for examination; now commonly known as an appeal. (5) Court of error, a court exercising appellate jurisdiction by means of writs of error. (6) Assignment of error, in law, specification of the error suggested or objected to. For ordinary errors, see **BULL**; **MISTAKE**.

**ERROR, Personal.** See **EQUATION, PERSONAL**.

**ERSCH**, ersh, **Johann Samuel**, German bibliographer: b. Grossglogau, 23 June 1766; d. Halle, 16 Jan. 1828. He was principal librarian and professor of geography and statistics at Halle, and is credited with being the founder of modern German bibliography. Among his publications are a 'Dictionary of French Writers'; 'Manual of German Literature'; and, in connection with Gruber, the 'Universal Encyclopædia of Arts and Sciences' (1818). This latter is a work of great merit.

**ERSE**, ers, a corruption of the word Irish; a name applied to Irish Gaelic people, and also to the lowlanders of Scotland. See **CELTIC LANGUAGES**; **CELTIC LITERATURE**.

**ERSKINE, David Stewart**, 11th EARL OF BUCHAN, Scottish author and antiquarian: b. 1742; d. 1829. He received his education at the University of Glasgow and in 1780 founded the Society of Scottish Antiquaries. He published 'An Account of the Life, Writings and Inventions of Napier of Merchiston' (1787); 'Essays on the Lives of Fletcher of Saltoun and the Poet Thomson' (1792); 'Anonymous and Fugitive Essays' (1812).

**ERSKINE, Ebenezer**, Scottish clergyman and founder of the Secession Church in Scotland: b. Dryburgh, Berwickshire, 22 June 1680; d. Stirling, 2 June 1754. He was ordained to the parish of Portmoak, Kinrosshire, in 1703, in which charge he remained 28 years, when he was translated to Stirling (1731). His attitude during the 'Marrow' controversy as well as his opposition to the system of patronage in the Church, led to a sentence equal to deposition being passed in 1733, which was recalled in the following year; in 1733 he with a few others made a formal act of secession; in 1737 he was joined by his brother, Ralph (q.v.); but it was not till 1740 that he was finally deposed from the ministry and his church closed to him. The Secession Church was split in twain in 1747 on the question of subscription to the civic oath then taken by the burghesses of Edinburgh, Glas-

gow and Perth, those who maintained its lawfulness, led by the Erskines, being called Burghers, and their opponents Anti-Burghers. So keen did feeling rise, that Erskine was formally deposed from the ministry by the Anti-Burghers. The breach in the ranks of the seceders was not healed until 1820. Erskine was the author of several volumes of sermons. His 'Life and Diary' were published in 1845. Consult his 'Life' by Ker, J., (1881); and MacEwen, 'The Erskines' (1900).

**ERSKINE, Henry**, Scottish barrister: b. Edinburgh, 1 Nov. 1746; d. Almondell, West Lothian, 8 Oct. 1817. He twice held the office of lord-advocate, was for long the leader of the Scottish bar and had a high reputation as a wit.

**ERSKINE, John (of Dun)**, Scottish reformer: b. 1509; d. 1591. He came of a noble family of which several members perished at the battle of Flodden Field. His early education was gained at King's College, Aberdeen. Having accidentally killed a priest his family sent him abroad to complete his education. On his return he introduced the study of Greek into Scotland. That he was one of the earliest supporters of John Knox is gathered from the fact that he was one of the signers of the first covenant of the Scottish reformers. He attended the marriage of Queen Mary in France as one of the special commissioners appointed for this purpose. Later Erskine assumed the rôle of mediator between Knox and the Queen. He was one of the compilers of 'The Second Book of Discipline' (1578).

**ERSKINE, John, of Carnock**, afterward of Cardross, Scottish jurist: b. 1695; d. near Dumbarton, 1 March 1768. He was called to the Scotch bar in 1719, was professor of Scots law in the University of Edinburgh, 1737-65, and was author of 'Principles of the Law of Scotland' (1754), and the 'Institutes of the Law of Scotland' (1773), both authorities.

**ERSKINE, John**, Scottish theologian: b. Edinburgh, 2 June 1721; d. there, 19 Jan. 1803. He was educated at the University of Edinburgh and at 22 received his license to preach. In 1744 he was ordained minister of Kirkintilloch, where he remained nine years, when he removed to Culross parish in Dunfermline presbytery. Five years later he removed to New Greyfriars, Edinburgh, and in 1767 to Old Greyfriars. He was for many years the leader of the evangelical party. He wrote many sermons and pamphlets of a theological nature. Consult Wellwood, 'Life of John Erskine' (Edinburgh 1818).

**ERSKINE, John**, American educator: b. New York, 5 Oct. 1879. He was graduated at Columbia University in 1900, and in 1909 became associate professor of English there. In 1903-09 he had served successively as instructor and associate professor of English at Amherst College. He has published 'The Elizabethan Lyric' (1903); 'Selections from the Faerie Queene' (1905); 'Actæon and Other Poems' (1907); 'Leading American Novelists' (1910); 'Written English,' with Helen Erskine (1910, rev. ed., 1913); 'Selections from the Idylls of the King' (1912); 'Poems of Wordsworth, Shelley and Keats,' with W. P. Trent (1914).

He has edited 'Contemporary War Poems' (1914); 'The Moral Obligation to be Intelligent and Other Essays' (1915); 'Interpretations of Literature by Lafcadio Hearn' (1915). He has contributed also to magazines and to the 'Encyclopedia Americana.'

**ERSKINE, Ralph**, Scottish seceder: b. 15 March 1685; d. Dumfermlin, 6 Nov. 1752. He was a brother of Ebenezer Erskine (q.v.). He was ordained to the collegiate charge of Dunfermline in 1711, and in 1737 joined his brother, who had seceded from the Established Church. His 'Gospel Sonnets' and other religious works were once very popular.

**ERSKINE, Thomas**, **BARON ERSKINE**, Scottish jurist: b. Edinburgh, 21 Jan. 1750; d. Almondell, West Lothian, 17 Nov. 1823. First in the navy and then in the army, he finally decided on a legal career at the suggestion of Lord Mansfield. He became a noted forensic orator and jurist, attaining early renown as a pleader in support of the accusations of corruption made against Lord Sandwich; later he added to his success by his defense of Stockdale, Lord George Gordon, Hardy, Thomas Paine, Horne Tooke and others. Some of his greatest successes were obtained in combating the doctrine of constructive treason, by which it was sought to make persons who aimed at effecting a change in the sovereign's constitutional character and position guilty of the capital offense of "compassing the king's death." His acceptance of a brief for Tom Paine resulted in his dismissal from the office of attorney-general to the Prince of Wales. He was a member of the House of Commons in 1790-1806, but achieved no success there. He was created Baron Erskine of Restormel, on becoming lord chancellor in 1806, holding office till the following year.

**ERSKINE, Thomas**, Scottish theological writer: b. Edinburgh, 1788; d. 1870. He studied law at the University of Edinburgh and practised this profession from 1810 to 1816, when he abandoned it for the literary field. Many of his views in matters of theology were unorthodox, such was especially the case with his theories of the atonement and universal restoration. He propounded his views so skilfully, however, that they impressed a great number very favorably. He was expelled from the Kirk in 1831 because of his heterodoxy. His writings include 'Remarks on the Internal Evidence of the Truth of Revealed Religion' (10th ed., 1878); 'The Unconditional Freedom of the Gospel' (1828); 'The Doctrine of Election' (1837; 2d ed., 1878); 'Spiritual Order and Other Papers' (1871). Consult his 'Letters,' edited by William Hanna (1877).

**ERTEL, är'tél, Jean Paul**, German composer: b. Posen, 1865. He studied composition under E. Tauwitz and piano under Liszt and Brassin. He is teacher at the Brandenburg Conservatory, Berlin, and musical critic of a Berlin newspaper. He collaborated on various publications and edited the *Deutsche Musikerzeitung* 1897-1905. His compositions include the symphonies 'Harald,' 'Maria Stuart,' 'Der Mensch,' 'Belsazar,' 'Pompeii'; besides several concertos and ballads.

**ERUPTION**, a term applied to a local disturbance in the skin characterized by the for-

mation of redness or scaliness, blistering or pustulation. In one class of affections, known as the eruptive fevers, a characteristic form of skin-eruption is diagnostic. Thus the fine red rash of scarlet fever, the bluish red rash of measles, the irregular rash of chickenpox and the pustulate rash of smallpox are readily recognized. The popular notion that an eruption is an indication of something evil within the body finding its way out belongs to the mediæval days of superstition and ignorance, when disease was regarded as an evil spirit to be exorcised, and gave notice of its evacuation by means of an eruption on the skin. At the present time we know that most eruptions are either of purely local occurrence, due to localized irritants, as in the case of pimples, boils, etc., or that they represent a disturbance of the nerve-centres, whose end-filaments are distributed to the epithelial structures of the body. Thus in measles, not only the skin, but also the mucous membranes of the respiratory tract are affected, the poison affecting the nerve-structures being evidenced by nerve-irritation at the periphery of the body. The popular idea that it is necessary to bring an eruption out in acute infectious diseases such as measles and scarlet fever is trustworthy, but an interpretation is frequently given to it that is not sound. The presence of an eruption on the surface of the body in these affections is an indication of the protective energies of the human organism in its fight with the infection and poisoning. The inability of the body to counteract the poison of the disease may prevent the development of the eruption, and thus its bringing out, being the sign of the body's ability successfully to cope with the poison, is the warrant for the popular idea of the efficiency of the eruption. Many drugs locally applied, or taken internally, cause the formation of eruptions. These eruptions may be due to purely nervous influences, or they may be of local origin. Drug-eruptions following the use of the iodides and bromides are of this latter character. As the drug is eliminated through the skin, its passage there causes local irritation and the formation of an eruption. See **DERMATITIS; MEASLES; SKIN AND SKIN DISEASES.**

**ERUPTIVE ROCKS.** See **IGNEOUS ROCKS.**

**ERWIN VON STEINBACH**, fön stin'-bah, German architect: b. Steinbach, Baden; d. 17 Jan. 1318. The principal tower of the cathedral of Strassburg had been completed in the 7th century. It was partly built of wood and was reduced to ruins by lightning and successive fires. The nave, begun in 1015, was only completed in 1275. Erwin was then requested to furnish designs for the decoration of the interior of the church and for the construction of two new towers and a façade upon the site of the ruins of the old tower. The foundation stone of the new structure was laid 25 May 1277. The architect died when the work was only half finished. It was continued by his son Johannes (d. 18 March 1339), and subsequently continued chiefly after his designs, still preserved at Strassburg. His daughter Sabina assisted him in the decoration of the interior of the church; and another of his sons, Winking (d. 1330), was also an architect of some distinction. The remains of this family of architects are interred within the cathedral.

**ERXLEBEN**, ärks'lä-ben, Johann Christian, German naturalist: b. Quedlinburg, 1744; d. 1777. He was educated at the University of Göttingen and in 1771 was appointed professor of natural philosophy there. He published 'Aufangsgründe der Naturgeschichte' (4th ed., 1791) and 'Aufangsgründe der Naturlehre' (8th ed., 1794). Erxleben's mother, Dorothea Christine Erxleben, was the first woman to obtain the degree of M.D. in Germany.

**ERYMANTHUS**, in ancient geography, a river (now called Douana) and mountain (now Olonos) of Arcadia, in Greece. The river, according to some the modern Dimitzana, rises on the frontiers of Arcadia and Elis, and flows into the Alpheüs. The mountain, situated to the east of the river, formed the western point of the northern barrier of Arcadia, and was covered with forests. It was in this mountain that Hercules chased and killed the famous wild boar.

**ERYNGIUM**, ɛ-rin'jī-ūm, a genus of plants of the parsley family (*Apiaceæ*). The generic name from the Greek refers to their thistle-like appearance. There are about 220 species in the genus, of which about 22 are found in America. Rattlesnake-master, or button-snakeroot (*E. aquaticum*) grows in wet soil and in the pinebarrens, from New Jersey south to Florida and west of Texas, Missouri and Minnesota. Its common names are given to it because of its supposed efficacy as an antidote to the venom of snakes. A number of species are cultivated, both on account of the steel-blue color of the stem and branches, and of the unusual manner of growth. Eryngo (*E. maritimum*), sea holly, is a native of Europe. It frequents sandy shores, and is distinguished by its rigid, spiny, glaucous, veined leaves and its dense heads of blue flowers. The roots are sometimes candied, and are reputed to be stimulating and restorative. Falstaff speaks of its use as a confection and its aphrodisiac qualities, either real or supposed, are mentioned by dramatists from Jonson to Prior.

**ERYON**, a fossil crustacean found in the rocks of the Mesozoic period in Europe. Six species have been identified of which *E. propinquus* is the best known. Consult CRUSTACEA; FOSSILS.

**ERYOPS**, a genus of fossil amphibians of the Permian rocks of Texas, which is of great interest as the ancestor of the extension order of labyrinth-odonts, according to the latest general opinion. Several species have been described, of which the best known (*E. megacephalus*) was six to eight feet in total length. It was sluggish, a water-and-shore living animal, in form something like a Californian horned toad and crept about on legs so short as hardly to lift its belly off the mud. Its skull was entirely encased in bone, save small holes for nostrils and eyes, and showed no sutures. The feet were broad and spreading and the tail short and contracted into a terminal pointed coccyx. Its ribs did not encircle the body, and it "probably swallowed air like a frog." "This animal," says Osborn, may be regarded as a collateral ancestor of the labyrinthodonts; it belongs to a type that spread all over Europe and North America, and persisted into the *Metopias* of the Triassic. Consult Osborn,

'Origin and Evolution of Life' (New York 1917); Gadow, 'Amphibia and Reptiles' (New-York 1901); Woodward, 'Guide to Fossil Reptiles' (in the British Museum, London 1905).

**ERYSICHTHON**, ɛr-i-sik'thōn, son of King Triopas, and himself a legendary king of Thessaly. He cut down trees in a sacred grove and he was cursed by Demeter with such unsatisfiable hunger that he devoured his own flesh. He is said to have repeatedly sold his own daughter; but each time she returned to him. She had received from Poseidon the power of self-transformation.

**ERYSIMUM**, ɛ-ris'ī-mūm, a genus of plants of the family *Brassicaceæ*, chiefly biennials, with narrow entire leaves, and yellow, often fragrant, flowers. There are about 85 species, natives of northern, temperate and cold countries. *E. cheiranthoides*, a native of Europe, with small yellow flowers, is found in waste places, along streams, and in fields from southern New England to Newfoundland, and westward to the Pacific coast.

**ERYSIPELAS**, an acute infectious disease of the skin and subcutaneous structures caused by a streptococcus. Whether the *Streptococcus erysipelatis* of Fehleisen, or the *Streptococcus pyogenes* is considered the causative factor or not, the fact remains that bacteriologically it is probable that these two forms of bacteria are identical. The reaction of the tissues to the streptococcus and its poisons causes the acute inflammation with redness, puffiness and sometimes gangrene. This local swelling is attended with fever, headache, general constitutional symptoms, nausea, vomiting, and at times with toxic delirium. Occasionally the streptococcus wanders into the blood-stream, and general septicemia or pyemia results. At other times a streptococcal invasion of the joints produces an acute rheumatism with secondary heart complications. Erysipelas may affect any part of the body, but is very frequently over the face and head. It is extremely contagious, the organism finding entrance through minute wounds. Patients who have had recent erysipelas should on no account be allowed to come anywhere near women in childbirth, as puerperal fever may result. The treatment of erysipelas is by means of tonic—iron and quinine being favorites—nutritious and easily assimilable diet, milk, cod-liver oil and some form of alcohol. In those patients in whom abscess formation occurs, prompt surgical evacuation is imperative. Local treatment by ichthyol and similar antiseptics is widely employed with some benefit.

**ERYSIPHACEÆ**. See MILDEW.

**ERYTHEMA**. See DERMATITIS.

**ERYTHIA**. See HESPERIDES.

**ERYTHRÆAN** (ɛr'ī-thrē'an) SEA, in ancient geography a name given to what is now called the Indian Ocean, but including the Persian and Arabian gulfs. The name was latterly restricted to the Arabian Gulf.

**ERYTHRIC ACID**, a white, crystalline, tasteless and odorless powder, readily soluble in alkalis and alcohol obtained from lichens.

**ERYTHRINA**. See CORAL-TREE.

**ERYTHRITE**, or "cobalt bloom," a native hydrous cobalt arsenate. It has a beautiful peach-blossom red color, whence its name from the Greek, *erythros*, red. It occurs in monoclinic crystals, but more commonly in globular or stellate masses or earthy. It occurs at Schneeberg, Saxony; in Cornwall, England; in Chile, and in some parts of the United States.

**ERYTHRONIUM**, a genus of small plants of the lily family, common in damp, shady woods, of which a well-known and widespread species (*E. americanum*) in the United States, is the "dog-tooth violet" or "adder's tongue"—both unfortunate names. It is among the earliest of spring flowers, appearing as two radical leaves, usually handsomely mottled, between which rises a slender, naked stem (scape) three to four inches high, bearing a single bell-shaped flower of six distinct lanceolate segments, pale yellow, often spotted near the base. About a dozen other species are known in the United States, some bearing several flowers on the scape, and of various tints, as purple, rose-color, or pinkish white.

**ERYTHROPLÆUM**, ê-rîth-rô-plê'um, a genus of tropical trees, of the pea family, containing five species, found in Africa, Asia and Australia. *E. guineense* of Africa has a poisonous red juice, which is used by the natives as a test of innocence or guilt, and hence the name ordeal-tree. The natives of Guinea and the Gold Coast employ the same juice to poison the points of their arrows.

**ERYTHROSIN**. See COAL-TAR PRODUCTS.

**ERYTHROXYLON**, a genus of plants of the family *Erythroxylaceæ*. The genus contains about 90 species, composed almost exclusively of trees and shrubs growing in tropical regions. The flowers are small and lack color; the fruit is a drupe. The red dyewood of Brazil is *E. suberosum*, and the oil-wood of Mauritius is *E. hypericifolium*. The chief member of the genus and family is *E. coca*. See COCA.

**ERYX**, ê'rîks, ancient name of a city and mountain in the west of Sicily, about six miles from Drepanum and two from the seacoast. The mountain, now Monte San Giuliano, rises direct from the plain, unconnected with any other range, and hence possesses a much greater altitude in appearance than in reality, its height being only 2,184 feet. It was anciently believed to be the highest mountain in the island after Etna, and is frequently alluded to by Virgil and other poets. On the summit stood a celebrated temple of Venus, from which the goddess received the epithet of Venus Erycina. All traces of the ancient town of Eryx have now disappeared, and its site is occupied by the modern town of San Giuliano; but some remains of the temple still exist in part of the substructure of the castle.

**ERZBERG**, ârts-bêrg, a mountain in Styria, Austria, near the town of Eisenerz. It rises about 5,000 feet above sea-level. It has valuable deposits of iron ore, reaching as high as 40 per cent metal, which is taken out annually to the amount of over 1,000,000 tons. Aragonite is also found in considerable quantity.

**ERZERUM**, êrz'room, **ERZEROUM**, or **ERZERROOM**, Turkey, a city of Armenia, and,

since the annexation of Kars by Russia, the chief strategical centre and place of resistance to a Russian advance, about 100 miles southwest of Trebizond. Its fortifications have been repaired and much improved since 1864. The inhabitants consist of Turks, Armenians and Persians and are very industrious; and, in addition to important manufacture, especially in copper and iron, carry on a very extensive trade. This is greatly favored by the position of the town, standing at the junction of several important roads leading from Transcaucasia by way of Trebizond, and communicating with different parts of Asia Minor, with Persia, Kurdistan, Mesopotamia, etc. Erzerum is a place of great antiquity. Anatolius, commander of the Emperor Theodosius II, here built the citadel of Theodosiopolis, northwest of the open Syro-Armenian trading town of Arsen. On the destruction of this town by the Seljuks, in 1049, the inhabitants removed to Theodosiopolis, which received from them the name of Arsen-er-Rum, that is, Arsen of the Romans. Hence the modern name Erzerum. In 1241 it fell into the hands of the Mongols, and in 1517 into those of the Turks, notwithstanding whose mismanagement it continued to be the most important commercial emporium of the Armenian plateau, and had a population of 100,000. In 1829 it was taken by the Russians, but was restored to Turkey by the Peace of Adrianople. Many of the inhabitants, however, quitted the town and settled in the Russian territory. In the winter of 1877 it was besieged by the Russians, who reduced the defenders by famine, until in February 1878 it was surrendered, and held by the Russians for several months. It was again, however, restored to the Turks. In the European War Erzerum fell a prize to the armies of the Grand Duke Nicolas, on 16 Feb. 1916, after an assault lasting five days. Turkish prisoners to the number of 13,000 were taken and 323 pieces of cannon. See WAR, EUROPEAN.

**ERZGEBIRGE**, ârts'gê-bêr-gê (German, Ore Mountains), a range of low mountains about 100 miles long on the boundary between Saxony and Bohemia. It is about 25 miles wide, and has an average elevation of 2,500 feet and a maximum of 4,060 (Mount Keilberg). On its sides are extensive forests, among which are many summer resorts. Like the Blue Ridge Mountains in the United States and the Highlands of Scotland, they are an ancient range, worn down and again uplifted. As the name implies, the Erzgebirge contain valuable deposits of minerals and form an old mining region. Silver ores were mined there as long ago as 1150 and mines of lead, copper, tin, cobalt, nickel and iron ore have also been sunk there.

**ERZINGAN**, êrz'zing-an, Turkey in Asia, town and capital of a sanjak in the vilayet of Erzerum, 85 miles south of Erzerum. It is situated in a plain at 3,900 feet above sea-level and is of importance as a garrison town. It has a military hospital, large barracks, government buildings, a mosque, a bazaar, an Armenian normal school, and other Armenian schools. It has manufactures of cotton, canvas, silk, copper and clothing. The government maintains several tanneries in the neighborhood. In 1784 most of the place was destroyed by an earth-

quake. In ancient times it was called Arsinga. Pop. 18,000, about equally divided between Armenian Christians and Mohammedans.

**ESARHADDON**, king of Assyria and son of Sennacherib. He reigned from 681 to 668 B.C. When his father was slain by his brothers, Esarhaddon proclaimed himself governor of Babylonia and set about avenging his father's death. Within a year he succeeded in having himself acknowledged king of Assyria. He conducted several campaigns against foreign enemies, first against the Chaldeans, capturing Sidon and razing that city. In 673-670 B.C. he made two campaigns in which he brought Egypt under his yoke. He died while on the way to repress an insurrection in Egypt in 668 B.C. He designated Assurbanipal as king of Assyria. He did much for the rebuilding of Babylon and planned many great building enterprises. His liberality has caused him to be considered one of the most beneficent kings of Assyria.

**ESAU**, the eldest son of Isaac, and twin brother of Jacob (Gen. xxv, 24-26). His name (which signifies rough, hairy) was due to his singular appearance at birth, being "red, and all over like a hairy garment." The struggle for precedence between the brothers was foreshadowed the moment of their first appearance in the world. Esau, the father's favorite, became a cunning hunter; Jacob, the favorite of the mother, became a peaceful shepherd. One day, as Esau returned famished from the chase, he found his brother preparing some lentil pottage, and asked for a share of it. Jacob, taking advantage of his brother's distress, offered him the pottage if he would give up his birthright. Although this meant yielding up the headship of the tribe and the greater share of the family property, Esau nevertheless consented. He was named Edom (red) in consequence, from the color of the pottage; and the name was given to the land he settled in. The next episode in his history is when Jacob, instigated by his mother, personated Esau, and succeeded in getting his father's covenant blessing. The indignation of Esau at the base trick was natural; and Rebekah sent Jacob out of the way for a time, to escape his brother's vengeance. On his return from a protracted stay Jacob succeeded in mollifying Esau by presents and flattery. After a subsequent meeting of the brothers, on the death of their father, we hear no more of Esau.

Many biblical scholars are inclined to look upon this story of Esau and Jacob as symbolical of the relationship existing between the Israelites and the Edomites. The characteristics of the former are well represented by Jacob and those of the latter by Esau. Edom, which was older than Israel, was subjected by David. See **EDOM**.

**ESBJERG**, ɛs'byɛrg, Denmark, seaport, 56 miles west of Fredericia, with a large export trade in cattle and dairy products, mostly to England. Its harbor, the only one of importance on the west coast of Jutland, was constructed by the state at great expense in 1868-74; and in 1887 an annual subsidy was granted by government for steam communication with Great Britain. A submarine cable connects with Calais. Pop. 18,208.

**ESCALADE**, ɛs-kā-lādd', in war, a furious attack of a wall or a rampart, carried on with

ladders, to pass the ditch or mount the rampart, without proceeding in form, breaking ground, or carrying on regular works to secure the men. See **WAR**.

**ESCALANTE**, ɛs-ka-lān'tā, Juan, Spanish soldier and explorer: d. 1519. He accompanied Cortés to Mexico and by the latter was made high constable of Villa Rica de Vera Cruz. He destroyed, on order of Cortés, the fleet which had brought the Spaniards from Spain and with 150 men, remained on the coast while Cortés marched against Mexico City. When two of his company were assassinated by the Indians Escalante set out with 50 whites and thousands of Indian allies to make reprisals on the hostile tribes. In the ensuing battle his forces were successful but he and seven of his white followers were slain.

**ESCALATOR**, the name applied to a continuous carrier designed for conveying passengers from one level to another within a limited time. The various units making up the escalator are so arranged that on the incline they present the familiar zigzag appearance of an ordinary stairway, and may be used as such. The escalator consists of an endless series of steps connected together by a heavy sprocket chain which, at the proper place, engages with the driving sprocket wheel. Each step is essentially a four-wheel truck, bolted to a shaft, which, in turn, is connected to the links of the driving chain. There are two wheels at each end of the truck traveling on separate tracks, so placed that the steps remain horizontal at all points of the ascent. At the landing, at the top and the bottom of the escalator, the trucks travel in the same plane so that the steps there become a moving platform. Ample opportunity is thus given, even to the infirm, to board the device before the ascent begins and at the top to step off again. A traveling hand-rail moving at the same speed as the steps further simplifies its use. Should a person fail for any reason to step off at the upper landing, a device called a shunt removes him from it. This consists of a box-like affair, triangular in plan, placed about 10 feet from the top of the escalator with the apex pointing against the direction of the moving platform. In the lower part, set in a vertical position, are two belts running backwards from the apex. Anything coming in contact with these belts is gently brushed to one side. Every part of the escalator is made to micrometer measurements of one thousandth of an inch by special machinery designed for the purpose. As a result of this unusual precision, the various steps fit together so nicely that a piece of paper cannot be forced between them. To secure practically noiseless operation, the wheels on which the trucks move are deadened, rawhide pinions are used in driving gear, and the tracks are built up of wood and steel. The links of the sprocket chain are made of two 18-inch cast steel shrouds, with 1½-inch steel pins between them at 3 inches between centres. The ends of the links are bushed with phosphor-bronze in which graphite is inlaid, thus providing lubrication of the bearing surfaces, and the heels are similarly provided with a constant lubrication of graphite. The escalator is driven by an electric motor located within the structure of the upper landing and suitably geared to the large driving sprocket wheel by a

combination of worm and spur gearing. All parts of the running gear are made of crucible cast steel, the axles and link pins being of cold drawn steel. Each casting is subjected to a test of many times the working-strain to come upon it.

While there are no mechanical limitations to the rate of speed with which the escalator may be driven, it has been found that a speed of about 100 feet per minute is satisfactory to the public. At this rate of driving, 4,000 steps per hour arrive at the landing and the maximum capacity of the machine depends upon the width of the steps used. The escalators which have been installed for railroad stations, large department stores and other localities where a large capacity is necessary, have been a little over five feet in width and as each step readily accommodates three people the maximum capacity of such a construction is 12,000 people per hour. For the smaller department stores and for use in railroad stations where the traffic is not heavy the escalator is made of such width as to accommodate one person on each step, and the capacity is therefore 4,000 per hour. It should be noted that the escalator is a perfectly reversible machine, operating equally well in either direction. In the "duplex" type, the steps during the descent are again guided into the familiar zigzag position by suitably placed tracks and thus the same machine serves to carry passengers both up and down. In a third modification of the device designed especially for the London underground railroad, where the difference between levels is considerable, the steps ascend in one spiral and descend in another spiral below the first.

**ESCALOP**, or **SHELL**, an heraldic symbol used to signify that the bearer has voyaged much on the sea. See **HERALDRY**.

**ESCANABA**, Mich., city and county-seat of Delta County, on Little Bay de Nouquette, an inlet of Green Bay; on the Chicago and Northwestern, and the Chicago, Milwaukee and Saint Paul railroads; 52 miles northeast of Marinette. Owing to its excellent and picturesque situation, it enjoys considerable reputation as a summer resort. The harbor has an eight-mile frontage and there is steamboat connection with several lake ports. Much of the Lake Superior iron ore is shipped from here. It contains eight ore docks, in which are handled over 4,000,000 tons annually, and there is, moreover, a large trade in coal, fish and lumber. There are manufactories of flooring, furniture and wooden ware, a plant for crushing iron ore, and large railroad repair shops. The United States census of manufactures for 1914 showed within the city limits 45 industrial establishments of factory grade, employing 921 persons; 777 being wage-earners receiving \$469,000 annually in wages. The capital invested aggregated \$1,354,000 and the year's output was valued at \$1,507,000: of this, \$771,000 was the value added by manufacture. The buildings of note are the public library, hospital, high school, courthouse and city hall. The city was settled in 1863, and was incorporated in 1883 and received its city charter in the same year. Pop. 14,747.

**ESCANDON**, Guillermo de Landa y, Mexican statesman: b. Mexico City. He was educated in Stonyhurst University, England; was several years a member of the national Senate,

representing the states of Chihuahua and Morelos; from 1900-02 he was mayor of Mexico City and became governor of the Federal District in 1903. Under his administration many very important reforms have been introduced and carried to successful results, among them the restriction or practical discontinuance of gambling; the improvement of the public carriage service; the enactment of rules restricting the speed of automobiles; the protection of the peon or Indian class; the improvement of the prisons of the capital city and its suburbs, and also of the public buildings and military barracks; the bettering of the sanitary condition of the correctional schools, the theatres and other places of amusement, and of the entire city; the adoption of a system of street sweeping and sprinkling; the placing of proper restrictions on the sale of alcoholic beverages, etc.

**ESCAPE**, the liberation of a person from lawful custody without lawful authority. When accomplished by the prisoner it is known as prison breach, but if accomplished by others and with force, it is known as rescue. Prison breach with force is a felony, but, if without force, merely a misdemeanor. In most modern jurisdictions a prisoner who effects his escape loses all commutation of sentence earned by him in any manner whatsoever. His aids in the escape, or even attempt to escape, are guilty of the same grade of crime as the prisoner and are liable to the same punishment. Officers who voluntarily permit an escape are considered as aids and punished as such. When guilty merely of negligence they are punished for a misdemeanor. See **CRIMINAL LAW**.

**ESCAPEMENT**, a part of the machinery in a watch or clock. See **CLOCK**; **WATCHMAKING**.

**ESCARP**, or **SCARP**, the slope of a ditch next the parapet. In permanent fortifications the escarp is usually faced with mason work behind which are erected casemates. See **FORTIFICATION**.

**ESCARPMENT**, the abrupt descent, which may or may not be a cliff, from a plateau to lower land. Particularly famous are the Hellderberg escarpment near Albany, and the Niagara escarpment, the latter responsible for Niagara Falls. The Allegheny Front is another well-known escarpment. See **MOUNTAINS**; **CLIFF**.

**ESCARS**. See **ESKERS**.

**ESCAUT**, ɛs-kō, the French name for the river Scheldt.

**ESCHALOT**. See **SHALLOT**.

**ESCHAR**, ɛs'kār, a portion of dead tissue, also the artificial slough produced by the use of caustics.

**ESCHATOLOGY**. The teaching in regard to the last things (Greek *ta eschata*). It deals with man's condition after death, the destiny of nations, and the end of the world. Speculation concerning the fate of the individual appears to have started in a very early period of man's career. Archæological remains indicate the presence of certain customs already in the paleolithic age which seem to reveal a nascent conception of survival after death. The disposal of the lifeless body so as to provide it with a shelter, the pictorial representation of men disguised by the heads of animals, and the cremation of the dead scarcely

permit any other interpretation. Sepulture, even in its simplest form, apparently implies the idea of something within man that may be temporarily absent but still demands a measure of sustenance and protection for the body. According to primitive notions among peoples surviving until to-day in stone age conditions, some of those that once lived in a neighborhood and, possessed of extraordinary power, created things may return in the guise of totems for the increase and strengthening of the tribe. The desire to have the double within, whose existence had been suggested by many an experience, united with the element of fire, for whose permanent possession man had so long struggled, is likely to have given rise to the incineration of the body. In the neolithic age specially constructed tombs, offerings of solid food and blood to the dead, and other customs testify to the growing belief in a survival dependent upon such ministrations. It is probable that the satisfaction of immediate needs, impulses, and passions precluded, in these remote ages, any serious concern about the future of the tribe, while the nomadic habits which allowed only a loose attachment to any particular place tended to prevent a local catastrophe from conjuring up the thought of an impending destruction of the whole world.

In various centres the early civilizations developed along different lines these ideas concerning the future. The Egyptians continued through thousands of years the practices of the neolithic age, though with some modifications. Tombs were differently constructed, bodies were embalmed, painted food was substituted for real, the mortuary ritual was enriched, but the underlying conception remained the same. Even when the Osirian theology gave a larger measure of independence to the soul, which had to appear before the judges in the nether world, the connection with the entombed body was never lost in popular thought. In periods of foreign invasion and social disorder the need was felt of some guarantees of a better future. While the Prophecies of an Egyptian Sage in a papyrus of the Middle Kingdom do not contain any distinctly predictive element, there is at least the suggestion of eschatological thought in the desire for a "shepherd of all the people, who has no evil in his heart." The freedom of the Nile valley from any devastating natural catastrophes was not conducive to ideas of an approaching end of the world. Our knowledge concerning the Ægean and Hittite civilizations is still too scanty to allow any definite conclusions on these points except such as may be inferred from the archæological remains. The belief in a survival through protection and care of the body is clearly evidenced by tombs and cultic performances. Whatever ideas the Greeks may have brought with them into their new home, they are likely to have been much influenced at the outset by their predecessors. In the Homeric Age it was thought that all souls pass at death to a shadowy and undesirable existence in Hades, unless for special reasons a hero is translated to dwell with the gods. This subterranean realm may be visited by an Odysseus still in the flesh. Speculation upon successive ages, symbolized by gold, silver, copper and iron appears in Hesiod, together with the suggestion that the process of degeneracy will end in destruction of the last

race. As the thought of a moral retribution beyond the grave asserted itself, the Orphic and Eleusinian mysteries offered to the initiated assurance of a blessed life after death and salvation from future punishments adjusted to the crimes committed. Among the Pythagoreans the idea of transmigration, probably of Eastern origin, was added to the Orphic conceptions. The primitive notion seems to have been that at death the soul is carried hither and thither by the wind until it enters another body. Plato developed this eschatological thought in various directions. He based immortality upon the essential nature of the soul as an eternal "idea" existing before birth and subsisting after death. While accepting the Orphic scheme of retribution, he emphasized the positive value and moral significance of life. He adopted the idea of the *annus magnus*, the cosmic year, thus anticipating the end of the present world; and he sought the realization by practical efforts of a society patterned upon the ideal, always limited, however, by the Greek conception of the city-state. Aristotle's attitude towards this development was on all points negative or agnostic.

In Babylonia, the Sumerians thought of the dead as going to a land below the earth whence there was no return, though some semi-divine heroes, like Engidu and Enmeduranki, might be spared the common lot and translated to be with the gods, and a Gilgamesh might find his way thither. Their mythical lore and astronomical observations furnished Akkadians, Amorites, Aramæans and Chaldæans with material for later speculation. But even these peoples do not seem to have developed any new type of thought concerning the future of the individual. While the growth of a peculiar astrological system, perhaps already in the Kassite period, may here and there have suggested the idea of the soul rising to life again, and apparently led to the conception of the great cosmic year, there is as yet no unmistakable evidence either that the inhabitants of Babylonia, Assyria and Mesopotamia before the Persian period became deeply concerned about existence after death, or considered intensely the future of the nation beyond some immediate emergency, or transferred the mythical imagery from the beginning to the end of the world. This was subsequently done in Syria. But even there the Hebrew writings reveal for long periods substantially the same ideas. The soul passes at death to a subterranean Sheol where there is no moral distinction. Only exceptionally an Enoch or Elijah may escape the universal fate and be translated. But the ethical fervor and insight of the great prophets, men like Amos and Hosea, Isaiah, Micah and Jeremiah, brought to the fore a conception of the nation as having a spiritual function, independent of the maintenance of the popular religious cult and the changing fortunes of the state. The extraordinary longevity of the Davidic dynasty tended to raise the expectation of a return of political independence and power under a scion of the old line. In some circles the thought, so touchingly expressed in the book of Job, that, from a longing for the work of his hands, the Creator might bring man back again from Sheol seems to have been entertained, though the author of that great poem resolutely brushes aside this

"hope of man." But the way was prepared for a new growth of eschatology through contact with Persian thought.

The Aryans of the Iranian plateau and India followed primitive tendencies into different directions. A religious practice of promptly returning the body to the various elements, rather than of preserving it, in connection with a growing demand for future retribution, seems to have led the former to the view that the body would ultimately be restored by the elements. Although the duty of exposing the dead and the doctrine of a physical resurrection, so strongly insisted upon in the later Avesta, are not alluded to in the Gathas, and the Achaemenian kings were buried, it is probable that they had long been maintained in certain Mazdayasnian circles, and they appear to have been known to Herodotus in the 5th and Theopompus in the 4th century B.C. That the world will pass through a final ordeal by fire is taught in the Gathas. The later Avesta divides the world-year, not according to the precession of the equinoxes into 25,868 years, but into 12 millennia, placing the advent of Zarathushtra at the end of the 9th, that of the Saoshyant, or Savior, who will raise the dead, at the end of the 12th. In India, on the other hand, the doctrine of transmigration became strongly entrenched, while a tendency toward pantheism excluded the idea of a creation and precluded the growth of eschatology. There are no last things in a pantheistic philosophy, though the infinite stretches of divine manifestation may be divided into *kalpas*, *yugas*, or epochs. The doctrine of metempsychosis renders it possible to introduce in the future life of the individual the nicest moral adjustments, implying both rewards and punishments in terms of character, and the possibility of rising and sinking in the scale of being according to present conduct. But this never-ending series of births and deaths may come to be felt as an intolerable evil, and Buddhism offered deliverance from the infinite wheel of existence in Nirvana. It is interesting to observe that the Aryanized people of Northern Europe not only believed in the assembly of all souls, except those translated to be with the gods, in Hel's subterranean realm, but also in punishments for the wicked, a destruction by fire of earth's crust, a new earth people by the descendants of the pure children Líf and Lífthraser, and a new dynasty of gods. The practical character of the Chinese has preserved ancestor worship, with its conservative influence, and given an ethical rather than metaphysical turn to philosophical thought, discouraging speculation about the future. How similar ideas may grow up, apparently without historical contact, from the natural operation of the human mind, is strikingly shown by the fact that the ancient Peruvians and Aztecs looked forward to the destruction of the world, analogous to its destruction by various agencies in past epochs, and also, it would seem, to a future restoration of the body.

The blending of Greek thought and Oriental speculation that followed the conquests of Alexander gave a powerful impulse to eschatology. Plato's idea of immortality, involving pre-existence as well as post-existence, and emphasizing deliverance from the prison-house of mat-

ter, spread in the East, while the Persian doctrine of a resurrection found its way to Syria, and in some Hellenistic circles a spiritual resurrection immediately after death was accepted as a compromise. The colorless existence in Sheol was reduced to an intermediate state between death and the final assize, while the Orphic pictures of heaven and hell helped to give a distinctive character to man's ultimate fate in the other world. Stoic philosophers set forth a theory of cycles according to which each cosmic year ends with a universal conflagration, leaving only the elements out of which a new world rises to pursue its course in exact repetition of its predecessor. Jewish apocalypses described a succession of world-empires and laid down a definite program of the last things with many features ultimately borrowed from Babylonian mythology. Sometimes the coming kingdom of heaven was thought of as ruled directly by God; some times a theocratic ruler on earth was expected, either a high-priest "of Aaron and Israel," as in the Zadokite Documents, or a king of the family of David and the tribe of Judah, as in the Psalter of Solomon and later works. Similar eschatological expectations of a heaven-sent ruler and savior of the world are found in the Fourth Eclogue of Virgil, the Priene inscription to Augustus, Sibylline oracles, probably of pagan origin, and elsewhere. In this atmosphere Christianity grew up. Jesus himself appears to have believed in a spiritual resurrection immediately after death of those accounted worthy of it, cherished no ambition to become a king or in other ways to exercise lordship, and looked for the kingdom of heaven essentially as a reign of righteousness in the life of man. But the belief that He had been raised from the dead according to the Scriptures and would return upon the clouds of heaven as the Messiah to take vengeance upon His enemies, raise the dead, and establish His kingdom on earth affected profoundly the thought of the early Church. When the expected return was delayed, the interest gradually shifted from the idea of a righteous kingdom on earth to the perfected society in heaven, which the travelers through purgatory might be assisted in attaining, but from which the denizens of hell are forever excluded. Yet in the greatest of all apocalypses Dante gives a glimpse of the final order of things on earth at the top of the mountain of purgatory in which all external authority has at last ceased. The poet realized, however, that before this stage can be reached when a citizen of the world may be left in freedom, righteousness and sanity to "crown and mitre" himself, a political organization of the whole human race under the same law would be necessary, and in 'De monarchia' suggested the need of an expansion of the empire to all parts in order to guarantee a general security and growth. When the Lutheran, Anglican and Reformed churches rejected the doctrine of a purgatory, they considered man's destiny to be fixed irrevocably at death. This tended to make the closing scenes of the last judgment and the resurrection of less practical importance, to eliminate the premillennial coming of Christ, and to present the millennium as a result of a long development of Christian life. Among Baptists and other radicals there was a reaction against this toward universalism or millen-



nlanism. A great crisis in the history of nations naturally produces a certain eschatological mood which leads some minds to seek new interpretations of old prophecies, and others to make forecasts of the future.

The Jewish and Christian doctrines of a final judgment, a resurrection of the dead, and everlasting punishments and rewards were adopted by Islam, and the eschatology was enriched, after the prophet's time, by contact with Persian thought. The idea of a reincarnation of some great representative of Allah in the past has exerted a particularly strong influence, and the expectation of some Imam or Mahdi to reveal the truth more fully or to change the conditions of life on earth has from time to time stirred profoundly the Mohammedan world. In later Judaism the denial by Maimonides of a physical resurrection found support at the time and has led more recently to a wide-spread hope for an immortal life independent of a resuscitation of the body. The disillusionment that has followed every Messianic movement has, no doubt, had something to do with the less prominent place held to-day even among orthodox Jews by speculation as to the advent of the Messiah. Neither conservatives nor liberals who are interested in the establishment of a Jewish state in Palestine seem to contemplate a monarchical constitution; and the fundamental difference between Jewish cosmopolitans and nationalists does not even affect the conviction that Israel has a particular function to fulfil in the regeneration of the human race.

Modern thought, freeing itself from the authority of tradition, has earnestly endeavored to test the foundations and appraise the value of the various eschatological conceptions, and to find out how far, and on what grounds, it is possible to formulate any views concerning the future that shall be in harmony with scientifically ascertainable facts. There is a disposition to examine objectively and impartially any evidence that is adduced, whether from the correspondence of the phenomena of consciousness to the operations of special parts of the brain or the alleged communications with the dead, the kinship of cerebral functions in man and animal or the intrinsic worth of human self-consciousness, the potentiality in all or the high degree of realization in some. Scientific inquiry, unable to go beyond a *non liquet*, may not find any ground for vetoing the assumption of an idealistic philosophy that the inmost self in man may be an indispensable unit in a spiritual universe. But there can be no question that the characteristic modern attitude, affected by science, is one of unwillingness to dogmatize, readiness to hold the judgment in suspense, and disinclination to regard knowledge in this field as essential. That the individual continues to live in the race is capable of demonstration, and to the consciousness of this fact a strong moral appeal is possible. An intelligent patriotism is to-day obliged to consider the future of the nation in connection with the whole system of sovereign and independent states. The political integration of these states into an all embracing league of nations is felt to be indispensable to the general security and looked forward to with confidence. Eschatological thought is intensely occupied at present with the changes, political, industrial, economic, social,

and religious, that are likely to follow the world war. It attaches itself again to the destiny of the earth. Barring an accident, which is always within the bounds of possibility, our planet may be expected to run its course through long ages before it passes away or ceases to be inhabitable. A new glacial period, however, probably lies in a much more immediate future. Living in an interval between two such periods particularly favorable to the development of civilization, we are threatened by the exhaustion of some supplies on which that civilization particularly seems to depend. A careful husbanding of all our natural resources, an equitable distribution to men and nations according to their needs, and a just regard for the necessities of coming generations will be called for. In the efforts to realize the eschatological ideals a moral energy may be released which shall constitute the most precious spiritual harvest of the life of man on earth.

**Bibliography.**—Déchelette, J., 'Manuel d'archéologie préhistorique' (1908-14); De Morgan, J., 'Les premières civilisations' (1909); Osborn, H. F., 'Men of the Old Stone Age' (1916); Meyer, Eduard, 'Geschichte des Altertums' (3d ed., 1913); Dietrich, A., 'Nekyia' (1893); Cumont, F., 'Les religions orientales dans le paganisme romain' (2d ed., 1909); Moore, G. F., 'History of Religions' (1914); Jastrow, M., 'Hebrew and Babylonian Tradition' (1914); Jeremias, A., 'Das Alte Testament im Lichte des Alten Orients' (1906); Tiele, C. P., 'Geschiedenis van den Godsdienst in de Oudheid' (1893-1902); Söderblom, N., 'La vie future d'après le mazdéisme' (1901); Marti, K., 'Geschichte der israelitischen Religion' (1897); Charles, R. H., 'Critical History of the Doctrine of a Future Life' (1899); Gressmann, H., 'Ursprung der israelitisch-jüdischen Eschatologie' (1905); Guy, L., 'Le millénarisme dans ses origines et son développement' (1904); Bousset, W., 'Religion des Judentums' (2d ed., 1906); Atzberger, P., 'Die christliche Eschatologie' (1890); Salmond, G., 'The Christian Doctrine of Immortality' (1897); Böhlen, A., 'Die Verwandtschaft der jüdisch-christlichen mit der parsischen Eschatologie' (1902); Dobschütz, A., 'Eschatology of the Gospels' (1910); MacCulloch, J., 'Early Christian Visions of the Other World' (1912); Schmidt, N., 'The Ethics of Dante' (1910); Myers, F. W. H., 'Human Personality; its Survival of Bodily Death' (1903); Ward, James, 'The Realm of Ends' (1911); Duncan, W. B., 'Immortality and Modern Thought' (1912); Adler, Felix, 'An Ethical Philosophy of Life' (1918).

NATHANIEL SCHMIDT,

*Professor of Semitic Languages and Literature,  
Cornell University.*

**ESCHEAT**, *ès-chèt'* (old French *eschet*, spoil, rent, that which falls to a person), the reversion of property to the sovereign. The law considers that all property must have an owner; so if a person die intestate and without issue, the property, in England, escheats to the king, and in America to the state as sovereign. In some jurisdictions, before the sovereign receives title there is a certain kind of proceeding to determine whether or not there are any heirs, while in other jurisdictions the sovereign gets the title on the death of the owner; but

even in these cases the sovereign's title is de-feasible until there are proceedings to determine that the deceased had no heirs. When the sovereign obtains title by escheat it acquires all the rights and privileges of the last owner, and the statutory requirements must be strictly followed, both as to the disposal of the property and as to the use of the fund derived from the sale, in case a sale is necessary. In the United States the powers and duties of the sovereign in relation to escheated property are controlled by statute in the different States. Formerly an escheat might arise through the failure of heirs or forfeiture for treason. In England the word escheat also signifies the district within which the king or lord is entitled to escheats; a writ to recover escheats; the escheated possessions of the state or lord; hence, generally, a return or reversion; and, more generally, that which falls to a person.

**ESCHENBACH**, ɛsh'ɛn-bāh, **Wolfram von**, German mediæval poet: b. Eschenbach, near Ansbach, Bavaria, about 1165; d. about 1220. He was one of the most prominent minstrels at the court of Hermann, Landgraf of Thuringia, where he spent part of his time, the other part being spent in Wildenberg (Wehlenberg). He was a contemporary of another very famous poet with whom he came into frequent contact at court. This was Walther von der Vogelweide (q.v.). According to his own statement he could neither read nor write but he had a very tenacious memory which enabled him to treasure up all the learning that came his way so that he soon became a marked character and finally was invited to the court and ultimately acquired all the education of the layman of his day. His work shows chivalry at its best. His epics rank among the greatest German imaginative works. Besides several love songs he wrote 'Parzival'; 'Wilhelm von Orange,' and 'Titulef, or the Guardian of the Graal.' See PARSIFAL.

**ESCHENBURG**, ɛsh'ɛn-boorg, **Johann Joachim**, German scholar: b. Hamburg, 1743; d. 1820. He received his education at the universities of Leipzig and Göttingen and in 1767 began his lifelong connection with the Collegium Carolinum in Brunswick, of which he was director after 1814. He published the first complete German translation of Shakespeare, 'Shakespeares theatralische Werke' (13 vols., 1782) and many other translations from English authors. He published also 'Handbuch der klassischen Litteratur' (1783); 'Entwurf einer Theorie und Litteratur der schönen Wissenschaften' (1783); 'Biespielsammlung zur Theorie und Litteratur der schönen Wissenschaften' (8 vols., 1788-95); 'Lehrbuch der Wissenschaftskunde' (1792); 'Denkmäler altdeutscher Dichtkunst' (1799), and the hymns 'Ich will dich noch im Tod erheben,' and 'Dir trau'ich, Gott, und wanke nicht.'

**ESCHENMAYER**, ɛsh'ɛn-mī-ér, **Adam Karl August von**, German philosopher: b. Neuenburg, July 1768; d. 1852. He was educated at the Caroline Academy, Stuttgart, and the University of Tübingen. He was for many years engaged in the practice of medicine at Sulz and Kirchheim. In 1811 he was appointed extraordinary professor of medicine and philosophy at Tübingen and in 1818 became

ordinary professor of practical philosophy. He resigned in 1836, removed to Kirchheim and thereafter devoted himself to philosophical study. He was inclined to a belief in mysticism as an aid to philosophy and took a deep interest in animal magnetism. In his later years his beliefs degenerated into a lower form of supernaturalism. He wrote 'Die Philosophie in ihrem Übergange zur Nichtphilosophie' (1803); 'Versuch die scheinbare Magie des thierischen Magnetismus aus physiologischen und physischen Gesetzen zu Erklären' (1816); 'System der Moralphilosophie' (1818); 'Psychologie in drei Theilen, als empirische, reine, angewandte' (2d ed., 1822); 'Religionsphilosophie' (3 vols., 1818-24); 'Die Hegelsche Religionsphilosophie verglichen mit dem christlichen Princip' (1834); 'Der Ischariotismus unserer Tage' (1835); 'Konflikt zwischen Himmel und Hölle, an dem Dämon eines besseren Mädchens beobachtet' (1837); 'Grundriss der Naturphilosophie' (1832); 'Grundzüge der christlichen Philosophie' (1840); 'Betrachtungen über physischen Weltbau' (1852).

**ESCHER**, ɛsh'ér, **Johann Heinrich Alfred**, Swiss statesman: b. Zürich 1819 d. there, 6 Dec. 1882. He studied law at Zürich, Bonn, Paris and Berlin and in 1844 became a member of the Cantonal Council of Zürich. In the following year he issued a summons for a general convention to be held at Unterstrass and having in view the expulsion of the Jesuits. As member of the Council of Education to which he was elected in 1846 he did much to place the educational system of the canton of Zürich on a truly modern basis. In 1847 Escher was made president of the Grand Council and in 1848 was elected to the Federal Diet. In 1849 he became president of the National Council and in 1856-57 and 1861-62 he served as vice-president and was later president of the Confederation for several terms. A bronze statue to his memory was erected by the citizens of Zürich. Consult Scherr, 'Alfred Escher' (1883).

**ESCHER VON DER LINTH**, **Arnold**, Swiss geologist: b. Zürich, 8 June 1807; d. 12 July 1872. He was the son of Hans Conrad Escher (q.v.). He was appointed professor of geology at the Zürich Polytechnic School in 1856. He made extensive researches which have caused him to be considered one of the foremost of the founders of Swiss geology. In 1852-53, in collaboration with Studer, he published the first detailed geological map of Switzerland. He wrote 'Geologische Bemerkungen über das nördliche Vorarlberg und einige angrenzenden Gegenden' (1853).

**ESCHER VON DER LINTH**, **Hans Conrad**, Swiss statesman: b. Zurich, 1767; d. 1823. He studied at the University of Göttingen in 1786-88 and from 1798 to 1802 was a member of the Legislative Assembly of Switzerland and at about the same period was editor of the *Schweizerischer Republikaner*. He retired from politics in 1802. In 1807-22 he served as president of the board of inspection of the canalization of the upper Limmat, known as the Linth. The improvement reclaimed hundreds of acres of fertile arable lands. Escher's popularity was at its height and his family received the surname of Von der Linth in 1823

as a recompense and recognition of his services to the republic. Consult Holtinger, 'Life of H. K. Escher von der Linth' (Zürich 1852).

**ESCHERICH**, ɛsh'er-ih, **Karl Leopold**, German entomologist: b. Schwandorf, 1871. He received his education at the universities of Munich, Würzburg, Leipzig and Heidelberg. Beginning in 1892 he made several tours including Tunis (1892), Asia Minor (1895), Algeria (1898), Abyssinia (1906), Ceylon (1910), and North America (1911). At Strassburg in 1901-06 he served as privatdozent and in the latter year was appointed professor at Tharandt Forestry Academy. He has published 'System der Lepismatiden' (1905); 'Der Ameise' (1906); 'Ferienreise nach Erythra' (1908); 'Die Termiten oder weissen Ameisen' (1909); 'Termitenleben auf Ceylon' (1910); 'Die angewandte Entomologie in den Vereinigten Staaten' (1913); 'Die Forstinsekten Mitteleuropas' (Vol. I, 1913).

**ESCHRICHT**, ɛsh'riht, **Daniel Frederik**, Danish zoologist: b. Copenhagen, 1798; d. 1863. He studied medicine in his native city, practised his profession for about three years, after which he studied physiology and comparative anatomy in France and Germany. After 1836 he held a chair at the University of Copenhagen. He published 'Haandbog i Physiologie' (1851) and 'Folkelige Foredrag' (1859). He left a valuable collection which now rests in the Zoological Museum.

**ESCHSCHOLTZ**, ɛsh'ólts, **Johann Friedrich**, Russian naturalist: b. Dorpat, government of Riga, 12 Nov. 1793; d. there, 10 May 1831. He studied medicine in his native city, and in 1819 became professor of anatomy and director of the zoological museum of the University of Dorpat. In 1815-18 and 1823-26 he accompanied Otto von Kotzebue in the latter's exploring tours around the world, collected a large number of natural history specimens and made valuable scientific studies on the lower organisms of deep-sea life. The results of his studies were published in Kotzebue's account of the expedition (1821), and he presented his collections to the University of Dorpat 1826. His catalogue of over 2,000 animals was published in Kotzebue's 'Neue Reise um die Welt' (Vol. II, 1830). Adelbert von Chamisso, another member of these expeditions, named a botanical species *Eschscholtzia* in his honor, and Eschscholtz Bay, on the Alaskan coast, is also named after him. He published 'Ideen zur Aneinanderreihung der rückgrätigen Tiere' (1819); 'System der Akalephen' (1829); 'Zoologischer Atlas' (5 parts, 1829-33), containing plates and distributions of new species of animals.

**ESCHSCHOLTZIA**, ɛ-shól'tsi-a, or **CALIFORNIA POPPY**, a genus of annual and perennial herbs of the natural order *Papaveraceae*, natives of the Pacific slope of the United States. The species, of which there are about a dozen, are distinguished by much dissected alternate leaves, yellow or white, showy flowers (the sepals united to form a deciduous hood), and a long capsular fruit resembling a silique. The best-known species is probably *E. californica*, a perennial which is widely cultivated as an annual in flower gardens, and is a beautiful orange-colored flower, one of the most showy in the whole floral kingdom. It is gre-

garious in habit, and in California it covers large areas with an almost unbroken orange-yellow bloom of striking beauty when seen on the gray-green slope of a treeless hillside. It is easily raised, especially if the seed be sown soon after gathering in the fall, and the young plants protected in cold climates.

**ESCHWEGE**, ɛsh'vá-gě, Germany, a town of the Prussian province of Hesse-Nassau, on the Werra, 26 miles east-southeast of Cassel. It is a walled and well-built town, with a castle, dating back to 1386, and long the residence of the landgraves of Hessen-Rotenberg, but now used as a public building. It is an important industrial centre and has manufactures of woolen and linen cloth, several large tanneries, glue-works, oil and other mills, and a trade in meal, fruit, lard, ham and sausages. Pop. about 13,000.

**ESCHWEILER**, ɛsh'vi-lër, Germany, town in the Prussian Rhine province, nine miles east-northeast of Aix-la-Chapelle, at the confluence of the Inde and Dente. It has manufactures of articles in iron and tin-plate, zinc and copper, machinery, boilers, railway plant, needles, wire, rolling-mills, smelting furnaces, belting and other leather goods, beer and birches. Calamine and lead, as well as productive coal-mines, are worked in the vicinity. Pop. 25,000.

**ESCHYNITE**. See *ÆSCHYNITE*.

**ESCOBAR Y MENDOZA**, Antonio, ăn-tō'ně-ō ɛs-kō-bār' ē mên-dō'thă, Spanish casuist: b. Valladolid, 1589; d. 4 July 1669. Entering the order of Jesuits in 1604, he became celebrated as a preacher and writer. At his death he left more than 40 volumes in folio, mostly in theology and morality, the principal being the casuistical 'Liber Theologiæ Moralis' (1646), which has several times been printed, and 'Summula Casuum Moralis' (1626). He seems to have been a man of exemplary moral character, but his writings unfortunately drew to themselves the ridicule of La Fontaine, Molière, Boileau, Pascal and other witty French writers, who represented him as a person of extreme moral laxity, of which the French word "escobarterie" became a strong and appealing symbol. They represented him as advancing the doctrine that the moral value of an action is to be found in the intention lying behind it, and that purity of purpose, may justify others contrary to the commonly accepted moral code. His writings were censured by the papal authority.

**ESCOBEDO**, Mariano, mă-rě-ă'nō ɛs-kō-bă-dō, Mexican soldier, popularly known as "orejones," big lugs, on account of his enormous ears: b. Dos Arroyos, New Leon, 12 Jan. 1827; d. Tacubaya, 22 May 1902. When the war between Mexico and the United States broke out he was a muleteer in charge of a string of pack mules belonging to his father. He converted his muleteers into a band of guerrillas, attacked small detachments of the American troops wherever he found them and took part in the battles of Palo Alto and Resaca. Juárez commissioned him colonel in 1859. In 1861, upon the establishment of Juárez' government in the City of Mexico, Escobedo was made a brigadier-general and sent in pursuit of the Clerical forces under Márquez and Mejia, but was surprised, taken prisoner after an heroic

defense, sentenced to be shot, but escaped and returned to Juárez. He took a prominent part in the war against the French which followed the intervention of Napoleon III in Mexican affairs. He repulsed them at Puebla, 5 May 1862, took part in the long siege of that place and when it was captured by the French, 17 May 1863, was taken prisoner, but succeeded in escaping. When Maximilian's empire was established, Escobedo took up his headquarters in Texas, secretly purchased arms and ammunition in New Orleans, 1865, organized and equipped a force of Mexican refugees, American negroes and ex-Confederate soldiers, led them into Mexico, captured the Imperial garrison at Monterey, November 1865, and swept everything before him. Juárez appointed him commander-in-chief of the Army of the North; he continued his victorious course until all the chief cities were in the hands of the republicans and finally besieged and defeated the Emperor at Queretaro, 15 May 1866. It is said that Maximilian offered his word of honor to Escobedo, on surrendering his sword, to leave the country at once if conducted to the nearest port; but Escobedo refused, probably on orders from Juárez, who ordered a court-martial, and the Emperor was condemned and executed. In 1874 Escobedo quelled an uprising against the government of Juárez, but was unsuccessful in putting down the revolution started by General Porfirio Díaz. He fled to Texas, issued a manifesto against Díaz, of whom he became a close friend and strong supporter later, and, later during his administration, president of the supreme military court of justice 1882-83. He also held other important offices of trust under Díaz.

**ESCOIQUIZ**, es'kō-ē-keth', **Juan**, Spanish ecclesiastic and politician: b. Navarre, 1762; d. Ronda, 27 Nov. 1820. He began life as a page at court in the reign of Charles III. He took holy orders and held a prebend at Saragossa. Through Godoy he advanced himself to the position of tutor to Ferdinand, the heir-apparent. His efforts in literature at this time consisted of a translation of Young's 'Night Thoughts' (1797) and a worthless epic on the conquest of Mexico (1798). He gained an ascendancy over his pupil, afterward Ferdinand VII, and he led the opposition to Godoy's plans for a French alliance. He was banished from court but maintained correspondence with Ferdinand. In 1807 he was implicated in the conspiracy of the Escorial, was imprisoned but later released with the other conspirators. After 1808 he became the trusted adviser of Ferdinand and prevailed on the latter to meet Napoleon at Bayonne, of which meeting he gives a vivid account in 'Idea Sencilla de las razones que motivaron el viage del Rey Fernando VII à Bayona' (1814). When the Spanish royal family was imprisoned by Napoleon, Escoiquiz accompanied Ferdinand. At the Restoration he was minister for a short period, but Ferdinand had tired of him, he soon fell into disgrace, was imprisoned in Murcia, recalled for a time and later exiled to Ronda.

**ESCORIAL**, or **ESCURIAL**, a royal palace of Spain, distant from Madrid about 24 miles (by rail 32 miles) in a northwesterly direction and situated on the acclivity of the Sierra de Guadarrama, the range of mountains which divide New from Old Castile. The

Escorial combines a monastery, a church and a mausoleum with a royal palace. Everything about the Escorial—situation, plan and purposes—bears the stamp of the sombre temperament and unpractical mind of its originator, Philip II. Not the least remarkable of its peculiarities is its site. Away from cities, amid the seclusion of mountain scenery, it stands at a height of 2,700 feet above the level of the sea. It was built in commemoration of the battle of Saint Quentin, which was fought on Saint Lawrence's Day (10 August) 1557 and to whom it is dedicated. The building is a rectangular parallelogram measuring 744 feet in length by 580 in breadth. The interior is divided into 13 courts, the plan supposedly in outline of the gridiron on which Saint Lawrence was broiled, while a projection 460 feet in length contains the chapel and the royal palace. The building, which is in the Greco-Roman style, was begun in 1563 by Juan Bautista de Toledo, a Toledan architect, and finished in 1584 by his pupil, Juan de Herrera. It is irregular in its proportions and thus loses much of the effect which, from its great magnitude, it ought to have. The innumerable windows (said to be 11,000 in honor of the Cologne virgins) give it the aspect of a large mill or barrack. The doors are also numerous. The material of the building is gray granite found in the neighborhood, which preserves its fresh and clean appearance. The church, which dominates the entire design, fronts on a central court, which was formerly opened only to admit the king on his first visit and a second time to receive his dead body for burial. The characteristic is majestic simplicity. It is 340 feet long by 234 wide; the central dome, 70 feet in diameter, is 320 feet high externally. Under the high altar is the Pantheon or burying-place of the kings of Spain. Its interior is lined with dark marble beautifully veined. One of the most interesting parts of the building is the cell of Philip II, from which the king in his last illness was enabled to witness the celebration of mass. The monasterial part of the building contains a valuable library, especially rich in Greek and Arabic manuscripts, and there was formerly a superb collection of pictures scattered through various parts of the building. During the French occupation the books, 30,000 in number, were removed to Madrid, but were sent back by Ferdinand minus 10,000 volumes. The Escorial was partly burned in 1671, when many MSS. were destroyed. It was pillaged by the French in 1808 (when the books were removed) and in 1813. It was restored by Ferdinand VII, but the monks, with their revenues which supported it, have long since disappeared, and the building, which from its situation requires to be kept in repair at considerable expense, has fallen into some decay, though repairs are executed from time to time. On 2 Oct. 1872 it was struck by lightning and was in consequence seriously injured by fire. The monastery portion of it is now a seminary in which youths receive a secular education. Consult Calvert, A. F., 'The Escorial; a Historical and Descriptive Account' (New York 1907); Hay, John, 'Castilian Days' (New York 1875).

**ESCORT** (French *escorte*), a guard, a body of armed men which attends an officer or baggage, provisions or munitions, conveyed by

land from place to place to protect them. This word is sometimes used for naval protectors; but the proper word in this case is convoy. In the United States escorts are of two kinds, funeral escorts and escorts of honor. The troops assigned for escort duty may consist of infantry, cavalry or artillery or all of them. The army regulations fix the character and size of escorts according to the military prominence or title of the individual. According to the United States Army Regulations of 1913, the funeral escort of a general of the army or the Secretary of War shall consist of a regiment of infantry, a squadron of cavalry and one battalion of field artillery; that of a lieutenant-general or the assistant Secretary of War, a regiment of infantry, a squadron of cavalry and a battery of field artillery; that of a major-general, a regiment of infantry, two troops of cavalry and a battery of field artillery; that of a brigadier-general, a regiment of infantry, a troop of cavalry and a platoon of field artillery; that of a colonel, a regiment; a lieutenant-colonel or major, a battalion or squadron; a captain, one company; a subaltern, a platoon.

**ESCOSURA**, ɛs-kō-soo'rá, Patricio de la, Spanish novelist and poet: b. Madrid, 5 Nov. 1807; d. there, 22 Jan. 1878. After various political and military ups and downs and being twice exiled, in 1855 he was sent as a special envoy to the Portuguese court, became Under-Secretary of State, Minister of the Interior and afterward Ambassador to Germany, 1872. He wrote the historical novels 'The Count de Candespina' (1832); 'Neither King nor Pawn' (1835); and 'The Patriarch of the Valley'; the epics 'The Bust in Black Cloak' and 'Hernan Cortés at Cholula'; several dramas, the most successful of which was 'Hernan Cortes' Debaucheries'; and several historical works, among them a 'Constitutional History of England' (1859).

**ESCROW**, in law, a written document sealed and delivered to the keeping of a third party to be held by him pending the fulfillment of certain conditions. Such an instrument is not a perfect deed and usually does not take effect until delivered by the custodian. Exceptions to the general rule are made when justice requires, or when the rights of outside parties are in need of protection. See **DEED**; **DELIVERY**.

**ESCUAGE**, ɛs'kü-áj. See **SCUTAGE**.

**ESCUERZO**, a Spanish term for toad, specifically applied in the valley of La Plata to a large local toad-like frog (*Ceratophrys ornata*) noted for its varied colors, laid on like those of a Persian carpet. This patchwork thoroughly conceals the toads as they lie half-buried in the ground. "If there is not enough green vegetation," says Gadow, "they throw, with their feet, little lumps of earth upon their backs, the skin of which becomes at the same time more wrinkled and assumes duller tones. There the creature lies, perfectly concealed, betrayed only by the metallic, glittering eyes, waiting for some unfortunate creature to pass into the trap represented by the enormous mouth, which opens and shuts with lightning rapidity and an audible snap." These frogs are of the *Cystignathine* group (see **FROG**) and closely allied to

the monstrous "horned toads" of Brazil. They live chiefly on frogs and are sometimes cannibals.

**ESCUINTLA**, ɛs-kēn'tlá, Guatemala, one of the southern departments of that republic; chief products, sugar cane, cacao and coffee. Its chief town, also called Escuintla, situated at an altitude of 1,269 feet above the level of the sea, on the line of the Central Railroad 30 miles southwest of Guatemala, has good hotels and apartment houses, and, owing to its baths, is a favorite winter resort. Pop. of Escuintla city 18,000.

**ESCULAPIANS**, a Catholic order, founded at Rome in 1614 and devoted to the education of poor and neglected children. At present it numbers about 2,000 members and has charge of 150 schools. See **ORDERS, RELIGIOUS**.

**ESCULENT SWALLOW**. See **SALANGANE**.

**ESCULIN, ESCULINE**. See **ÆSCULIN**.

**ESCURIAL**. See **ESCORIAL**.

**ESCUTCHEON**, ɛs-küch'ōn, in heraldry, is derived from the Old French *escusson*, French *écusson*, and that from the Latin *scutum*, a shield. It signifies the shield whereon coats of arms are represented. See **HERALDRY**.

**ESDRAELON**, ɛs-drā-ē'lōn or ɛs-drā-ɛ'lōn (Merdj-Ibn-Amer), the famous and beautiful plain in Palestine, situated between the mountains forming the western watershed of the Jordan and the Mediterranean Sea. In the Old Testament it is called Jezreel, valley of Megiddo, the Great Plain; in the New Testament, Armageddon. It is triangular in form, 36 miles in length, with an average width of 15 miles. On its boundary are: on the northeast Mount Tabor, the southeast Mount Gilboa, and on the southwest Mount Carmel. The principal streams are Nahr-el-Djalood, which flows into the Jordan, and the Kishon (Nahr-el-Moukataan) which flows into the Bay of Acre just north of Mount Carmel. Other streams traverse the plain, but are chiefly branches of the two streams mentioned. The soil is fertile and when cultivated with care yields good crops. When Esdraelon was traversed by caravans crossing Palestine from the rich countries east and west, grains, vegetables and fruits were raised in abundance. Agriculture is again receiving attention. Some of the noted places on this plain are Djeneen (probably the old town of Engannin), at the entrance to the plain and 984 feet above the sea. Tradition says this is where the 10 lepers were cured (Luke xvii); Zerlin, known by the residents as Zeraeen, called by the Crusaders Petit-Guérin, is now a large village. Near it is the fountain, Ain-Maeeteh, supposed to be where Saul camped when at war with the Philistines (1 Sam. xxxi). Ain-Djalood, said to be the place where Gideon selected the 300 men who fought and defeated the Midianites (Judges vii). On the south side of the Kishon are the villages of Afooleh, El-Fooleh and Zerlin. Afooleh is the old town of Aphec, one of the places where the Assyrians and Egyptians met in battle. At El-Fooleh was once a fortress built by the Templars, but destroyed by Saladin in 1187. Here in 1799 a battle between French troops under Napoleon, 4,000 in number, and the Mohammedans, 35,000

in number, left the French the victory. Ruins of the fort exist. For the ancient history of Esdraelon consult the Old Testament; many of the important places mentioned in the New Testament are in a good state of preservation. Nazareth, Nain and all the surrounding section west of Mount Tabor are usually included in the plain, and must be so considered if Mount Tabor is accepted as on the northeast boundary. Consult Costello, 'The Gospel Story'; Thomas, 'Two Years in Palestine'; Sayce, 'Patriarchal Palestine'; Smith, 'Historical Geography of the Holy Land. See ARMAGEDDON.

**ESDRAS, Books of**, two apocryphal books, which, in the Vulgate and other editions, are incorporated with the canonical books of Scripture. In the Vulgate the canonical books of Ezra and Nehemiah are called the first and second, and the apocryphal books the third and fourth books of Esdras. The Geneva Bible (1560) first adopted the present nomenclature, calling the two apocryphal books first and second Esdras. The subject of the first book of Esdras is the same as that of Ezra and Nehemiah, and in general it appears to be copied from the canonical Scriptures. The second book of Esdras is supposed to have been either of much later date, or to have been interpolated by Christian writers. This book takes its name from the supposed writer, a priest and doctor of the law, called Ezra by the Hebrews.

**ESERINE**, or **PHYSOSTIGMIN**, a drug obtained from Calabar-bean, the active principle of this plant, used as a remedy in cases of tetanus (lockjaw). A solution of eserine dropped into the eye causes contraction of the pupil, and hence its use in some eye ailments, as, for instance, glaucoma.

**ESHER, Reginald Baliol Brett**, 2d Viscount, English writer: b. London, 30 June 1852. He was educated at Eton and Cambridge, and was private secretary to the Marquis of Hartington 1878-85. He was member of Parliament for Falmouth 1880-85; from 1895 to 1902 was secretary to H. M. Office of Works; and was chairman of the Territorial Forces Association, county of London, 1909-13. He succeeded his father as viscount in 1899. He has written 'Footprints of Statesmen' (1892); 'The Correspondence of Queen Victoria' (1907); 'Today and To-morrow' (1910); 'The Girlhood of Queen Victoria' (1912); 'Influence of King Edward: Essays' (1914).

**ESHER, William Baliol Brett**, 1st Viscount, English jurist: b. Chelsea, 13 Aug. 1817; d. London, 24 May 1899. He received his education at Westminster and at Caius College, Cambridge, and was called to the bar in 1840. He entered Parliament in 1866 as a Conservative and two years later was made solicitor-general and within a few months was appointed justice of the Court of Common Pleas. He was made lord justice in 1876 and in 1883 succeeded Jessel as master of the rolls. In 1885 he entered the House of Lords as Baron Esher. In 1897 he retired from the bench and a viscounty was bestowed on him. Several of his decisions were severely criticized and while an able lawyer he was on the whole reactionary and his judgments belong to an earlier and more conservative age.

**ESHER**, England, village in Surrey, 15 miles southwest of London. Claremont Park, where the Princess Charlotte resided and died, and the ruins of Esher Palace, built in the 15th century, are in the neighborhood. Pop. of parish 2,609.

**ESK** (Celtic for water), the name of two small rivers in England, one in Cumberland and one in Yorkshire; and of several in Scotland, the chief being the Esk in Dumfriesshire; the North Esk and South Esk in Forfarshire; and the North Esk and South Esk in Edinburghshire.

**ESKER**, a narrow winding ridge of stratified glacio-fluvial sand and gravel, frequently extending across the country for miles with little regard for hills and valleys. Eskers are believed to have been formed by deposition from subglacial streams in tunnels under the ice. They are also known as osars or sometimes as Serpentine kames.

**ESKI-SAGRA**, ɛs'ki-sā'grā, or **EZKI ZAGHRA**, Bulgaria, a town in eastern Rumelia, on the south slope of the Balkans, about 100 miles northwest of Adrianople. It is near the chief passes of the Balkan Mountains, and its advantageous location is favorable to its trade. The mineral springs and extensive rose gardens nearby are sources of wealth for the town. Some of the manufactures are carpets, coarse linen, leather and rose oil. It was one of the South Balkan strongholds of the Turks which repelled the Russians in 1877. Pop. 22,003.

**ESKI-SHEHR**, ɛs'ki-shēhr' (ancient DORYLÆUM), Turkey, town 90 miles southeast of the sea of Marmora. It has warm mineral springs, and manufactures of meerschaum pipes from the deposits of meerschaum in the neighborhood. The surrounding region is noted for the quantity and quality of the meerschaum deposit. About two-thirds of the people are Mohammedans and the remainder are Christians. Pop. 20,000.

**ESKI-ZAGRA**. See STARA-ZAGORA.

**ESKILSTUNA**, ɛsk'il-stoo-nā, Sweden, city 57 miles west of Stockholm, on the river of Eskilstuna, connecting Lake Maelar with Lake Hjelmar. It has daily communication with Stockholm, both by steamer and rail. On an island in the river is a large gun factory, and its manufactures of iron and steel products are so great that it is called the "Sheffield of Sweden." The place takes its name from Saint Eskill, an English missionary of the 11th century, who, it is said, suffered martyrdom here. Pop. 28,485.

**ESKIMO DOG**, sledge dog, the draught animal of the Arctic regions. It is a wolfish-looking dog, largely or sometimes wholly derived from the wolf, tinged with yellow or with a grayish color, having an outer coat of long hair, and an undercoat of soft wool. Its short pricked ears and bushy tail add to its wolf-like appearance. Its cry is not a bark, but a long melancholy wail. This dog is trained to hunt the polar bear and to drag the Eskimo's burdens over the rough ice, when harnessed in trains to sledges, and is highly prized in the frozen North.

**ESKIMO, ESKIMOS** (Abnaki, Eskimansic: Ojibwaw, Askkimey, eaters of raw flesh), or **ESQUIMAUX**, es'ki-mō, the name of the

inhabitants of the northern coast of the American continent down to lat. 60° N. on the west, and 55° on the east, and of the Arctic islands, Greenland, and about 400 miles of the nearest Asiatic coast. They prefer the vicinity of the seashore, from which they rarely withdraw more than from 20 to 80 miles. Their number scarcely amounts to 40,000. Nevertheless they are scattered as the sole native occupants of regions stretching 3,200 miles in a straight line east and west, to travel between the extreme points of which would necessitate a journey of no less than 5,000 miles. This distance, taken in connection with their homogeneous nature and manners, makes their small bands the most thinly scattered people of the globe. Their extraordinary persistency in maintaining their language and habits must be due to the difficulties they have had to face in procuring subsistence. They call themselves *Innuït Yuit*, *You-Kouk* (the people).

**Race.**—They used to be classed among nations of the Mongolian stock; but now they are considered as akin to the American Indians. Their height is from five feet two inches to five feet six inches. They appear comparatively taller sitting than standing. Their hands and feet are small, their faces oval, but rather broad in the lower part; their skin is only slightly brown; they have coarse black hair and very little beard. The skull is high.

**Habits.**—The Eskimos get their subsistence mostly from hunting by sea, using for this purpose skin boats where the sea is open, and dog sledges on the ice. From the skin, blubber, and flesh of the seal and the cetaceous animals, they procure clothes, fuel, light and food. Their most interesting as well as important invention for hunting is the well-known small skin boat for one man, called the kayak. It is formed of a framework covered with skin, and, together with his waterproof jacket, it completely protects the man against the waves, so that he is able to rise unhurt by means of his paddle, even should he capsize. In winter the Eskimos are stationary. But, during the summer, when sufficient open water is found, they roam about in their large skin boats. Their winter dwellings vary with regard to the materials of which they are built, as well as in their form. In the farthest west they are constructed mostly of planks, covered only with a layer of turf or sod; in Greenland the walls consist of stones and sod; in the central regions the houses are formed merely out of snow. In Alaska the interior is a square room, surrounded by the sleeping places, with the entrance on one side, while a hearth with wood as fuel occupies the middle of the floor. The number of inhabitants at an Eskimo station or village is generally under 40, but in rare cases more than 200 are found. A funnel-shaped, half-underground passage forms the entrance of the narrow dwellings.

**Dress.**—The dress of the Eskimos is almost the same for the women as for the men, consisting of trousers or breeches and a tunic or coat fitting close to the body, and covering also the head by a prolongation that forms the hood. For women with children to carry, this hood is widened so as to make it an excellent cradle, the *amaut*. Tattooing has been general among all the tribes. The ordinary materials

of which clothes are made are the skins of seals, land animals and birds.

**Language.**—The language is characterized by the power of expressing in one word a whole sentence in which are embodied a number of ideas which in other languages require separate words. The Greenland dictionary contains 1,370 radicals and about 200 affixes. A radical may be made the foundation of thousands of derivatives, and a word can be composed which expresses with perfect distinctness what in our civilized languages might require 20 words. In Greenland and Labrador the missionaries have adopted the Roman letters for reducing the native language to writing. The printed Greenland literature, including what has been published by the Moravian Brethren, amounts, with pamphlets and the like, to what might make 70 to 80 ordinary volumes.

**Sociology.**—It is doubtful whether an organization like that of the Indian "families" has been discovered among the Eskimos. But a division into tribes, each with their separate territories, actually exists. The tribe again is divided into groups constituting the inhabitants of the different wintering places. Finally, in the same station, the inhabitants of the same house are closely united with regard to common housekeeping.

**Religion.**—The inhabitants of Danish West Greenland, numbering about 10,000, the greater part of the Labradorians, and the southern Alaskan Eskimos are christianized. As for the rest, the religion of the Eskimos is what is generally designated as Shamanism.

The Eskimos are believed by some to have come from the interior of America, and, following the river courses, to have arrived at the Arctic sea, where they have developed their abilities as an Arctic coast people. The Eskimos may be divided into the following groups: (1) The Western Eskimos, inhabiting the Alaska territory and the Asiatic side of Bering Strait; (2) the Mackenzie Eskimos, or Tchiglit, from Barter Island to Cape Bathurst; (3) the inhabitants of the central regions, including the Arctic Archipelago; (4) the Labradorians; (5) the Greenlanders; a side branch inhabiting the Aleutian Islands, speak a dialect considerably different from that of the rest of the Eskimo people.

The Christianized natives still preserve their ancient folklore. It represents at the same time their original poetry, religious ideas and history, praising the deeds of their great men in braving the dangers to which their race has been continually subjected. The 'Tales and Traditions of the Eskimo' (1875) comprises a collection of 150 tales founded on versions supplied by about 50 narrators from different parts of Greenland, and a few from Labrador. A valuable collection has since been acquired from East Greenland, some tales from Baffin Land, and a number of the simplest fragments of the same from Bering Strait. See ALASKA; POLAR RESEARCH; ETHNOLOGY; GREENLAND; LABRADOR.

**Bibliography.**—Boas, 'The Central Eskimo' (Bureau of Ethnology 6th Annual Report); McLean, 'Notes on the Hudson Bay Territory' (1846); Hall, 'Life with the Eskimos' (1864); Rink, 'The Eskimo Tribes' (1887); 'Traditions of the Eskimos' (London 1875); 'Danish Greenland' (London 1887); Pilling, 'Bibliog-

raphy of the Eskimo Language' (1888); Peary, 'My Arctic Journal' (1893); Nansen, 'Eskimo Life' (1894); Thalbitzer, 'A Phonetical Study of the Eskimo Language' (Copenhagen 1914); Stefansson, 'My Life with the Eskimo' (London 1913); Morillot, 'Mythologie et Légendes des Esquimaux de Greenland' (Actes de la Société Philologique, 1874); Richardson, 'Polar Regions' (1861).

**ESLA**, a river in Spain, which rises in the Cantabrian Mountains and flows south for 150 miles through León and Zamora and empties into the Duero, 20 miles below Ciudad Zamora.

**ESLAVA**, Miguel Hilarion, Spanish composer: b. Burlada, 1807; d. 1878. He was appointed maestro in Ossuña cathedral at the age of 21. Later he became a priest and in 1832 removed to Seville. Queen Isabella appointed him court maestro at Madrid in 1844. He produced the operas 'El solitario' (1841); 'Las treguas de Tolemaida' (1842); 'Pietro el crudele' (1843); the collections 'Museo orgánico español'; 'Lira sacro-hispana' (1869); also 150 masses, psalms, etc.

**ESLAVA**, Sebastián de, Spanish soldier: b. Navarre, 1714; d. Madrid, 1789. He was one of the first graduates of the Real Academia Militar of Barcelona. He won distinction in the campaigns undertaken by Philip V, was made lieutenant-general in 1738 and two years later viceroy of New Granada, the present republic of Colombia, South America. He strengthened the fort at Cartagena and defended it successfully against the English under Sir Edward Vernon in 1741. He returned to Spain in 1748, was advanced to the grade of captain-general and in 1750 made governor of Andalusia. Four years later he was made War Minister and retired from public life on the accession of Charles III.

**ESMANN**, ës'män, Gustav Frederik, Danish dramatist: b. Copenhagen, 17 Aug. 1860; d. 1904. After a short period of legal study, he abandoned law for literature and his first work was a volume containing two short stories, 'Gammel Gjaeld' (1885). Thereafter he devoted himself mainly to dramatic composition and a notable series of plays, which have been acted with great success throughout the Scandinavian countries, have come from his pen. They are: 'I Stiftelsen' (1886); 'Enkemænd'; 'For Bryllupet'; 'I Provinsen' (1890); 'Den Kære Familie' (1892); 'Magdalene' (1893); 'Den Store Maskerade' (1895); 'Vandrefalken' (1898); 'Det Gamle Hjem' (1899); 'Sangerinden' (1901).

**ESMARCH**, Johannes Friedrich August, yō-hän'nēs fréd'rīn ow'goost ës'marn, German military surgeon: b. Tönning, Schleswig-Holstein, 9 Jan. 1823; d. 23 Feb. 1908. He received his medical and surgical education in the universities of Kiel and Göttingen, and in 1860 was appointed director of the Kiel Hospital. In 1870 he was a member of the hospital commission of the Prussian army, physician-general and consulting surgeon of the army and introduced a system of bloodless operations and originated noteworthy improvements in ambulances and barrack hospitals. In the autumn of 1888 he made a trip to the United States. He was an authority on gunshot wounds. Among his published works are 'Ueber Resektionen nach Schusswunden'

(1851); 'Beiträge zur praktischen Chirurgie' (1853-60); 'Ueber chronische Gelenkentzündungen' (1867); 'Ueber den Kampf der Humanität gegen die Schrecken des Krieges' (1869); 'Der erste Verband auf dem Schlachtfelde' (1899, 3d ed.); 'Verbandplatz und Feldlazarett' (1871); 'Ueber künstliche Blutteere bei Operationen' (1873); 'Handbuch der kriegschirurgischen Technik' (1877); 'Die erste Hilfe bei plötzlichen Unglücksfällen' (1901).

**ESMENARD**, Joseph Alphonse, French editor and poet: b. Pélassane, Bouches du Rhône, 1769; d. 1811. He came to Paris about 1797 and became coeditor of *La Quotidienne* and in the following year of *Le Mercure de France*. He was secretary to Villaret-Joyeuse, governor of Martinique under the Consulate, and in 1804 was consul in the island of Saint Thomas. In 1805 he published 'La navigation,' a poem inspired by his early travels in America. In 1810 he was elected to the Academy. Soon afterward a caustic article on Russia in *Le Journal de l'Empire* so annoyed Napoleon that he banished Esmenard from France.

**ESMERALDAN**, a linguistic stock of aborigines of South America, who formerly dwelt along the Esmeraldas River in northern Ecuador. Consult Rivet (in *L'Année linguistique*, 1908-10) and Seler, 'Geschichte Abh. zur amerikanischen Sprach- und Altertumskunde' (Vol. I, pp. 49-64, Berlin 1902).

**ESMOND**, Henry V., (real name, Jack), English actor and dramatic author: b. Hampton Court, 1869. He was educated by private tutors, went on the stage in 1885 but after 10 years abandoned it for the dramatic field. He produced 'Rest'; 'Bogey' and 'The Divided Way'; 'One Summer's Day' (1897); 'Grierson's Way' (1899); 'The Wilderness' (1901); 'When We were Twenty-one' (1901); 'The Sentimentalist'; 'My Lady Virtue' (1902); 'Billy's Little Love Affair' (1903); 'The O'Grindles' (1907); 'Under the Greenwood Tree' (1907); 'A Young Man's Fancy' (1912). Consult Winter, W., 'The Wallet of Time' (2 vols., New York 1913).

**ESNAMBUC**, Pierre Belain d', French navigator: b. Allonville, 1585; d. 1636. While commanding a vessel in the Caribbean he seized the island of Saint Christopher and so established his title as founder of the French settlements in that region. He suggested a plan for dividing the island between France and England which was approved. He brought about 500 immigrants there in 1626 and in the remaining years of his life founded colonies on Martinique and other islands of the Antillean group. He was the founder of the town and fort of Saint Pierre, which was annihilated by a volcanic eruption on 8 May 1902.

**ESNEH**, ës'nē, or **ESNE**, a town in upper Egypt, about 30 miles above Thebes on the left bank of the Nile. It is a seat of manufactures, produces blue cotton cloth and pottery and is a depot of caravans from Abyssinia and Sennar. The town was anciently called Latopolis; and was the centre of worship of the fish latus, a species of carp. Among the ruins of this once populous city is the temple, whose portico is in good preservation, having 24 beautiful columns and a zodiac on the ceiling. Coptic remains are in the neighborhood. The Christians



here suffered severely in the persecution under Diocletian (A.D. 303).

**ESOCIDÆ**, ě-sós'ĭ-dē. See **LUCIDÆ**.

**ESOP**. See **ÆSOP**.

**ESOPUS FORMATION**. See **CAUDA-GALLI GRIT**.

**ESOPUS WAR**, a long-continued and desultory conflict between the Dutch and the Indians at a place in Ulster County, N. Y., known to the Indians as Esopus, but now called Kingston. This series of skirmishes began in 1658, when the Dutch fired upon some Indian farm hands, who were drunk and riotous. Esopus, which the Dutch called Wiltwyck, was at last destroyed by the aborigines, who carried off 40 women and children and killed 21 men. Governor Stuyvesant sent out a strong force to punish the Indians, and in May 1664 a treaty of friendship was ratified.

**ESOTERIC**, ěs-ō-tēr'ik (Gr. *ἑσωτερικός*, "inner"), a term used in opposition to exoteric. In reference to the teaching of Pythagoras, Aristotle, and other ancient philosophers, it refers to those doctrines which they expounded to their select disciples, in contradistinction to those which they published to all the world (exoteric). The distinction does not necessarily imply that the esoteric doctrines were kept secret as a mystery, but only that they were of a higher and more difficult order. (See **ARISTOTLE**; **PYTHAGORAS**). Consult Christ-Schmid, 'Geschichte der Griechischen Litteratur' (Munich 1908).

**ESPALIER**, ěs-pāl'yér, in gardening, a sort of trellis-work on which the branches of fruit-trees or bushes are extended horizontally, with the object of securing for the plant a freer circulation of air as well as a full exposure to the sun. Trees thus trained are not subjected to such marked nor so rapid variations of temperature as wall-trees. The term is most commonly used in France, where it is applied to a row of trees planted along a wall. See **TRELLIS**.

**ESPARSETTE**. See **SAINFOIN**.

**ESPARTERO**, Baldomero, bāl'dō-mā'rō ěs-pār-tā'rō, DUKE OF VITORIA, Spanish statesman: b. Granatula, 27 Feb. 1792; d. Logrono, 9 Jan. 1879. The son of a wheelwright, he was educated for the priesthood, but joined the army as a volunteer in 1808 and continued with it fighting against Napoleon until 1814. Shortly afterward he went to South America where he served in the army of Spain against the revolting colonists. He returned in 1824 and took a leading part in the conflict with the Carlists and was one of the most prominent men in Spain during several decades of the 19th century. He was lieutenant-general and commander-in-chief on two separate occasions. In this capacity he twice held Madrid against the Carlists (in 1836 and 1837); and by the Agreement of Vergara (1839) entered into with Maroto, he forced Don Carlos to withdraw from Spain. In reward for these services to the Crown he was granted the titles of Duke of Vitoria, Duke of Morelia and grandee of Spain. In 1841, on the resignation of the regency by the Queen Mother, Maria Christina, he became regent. Two years later he was forced into exile, which he spent in England.

He returned to Spain in 1848 and became again head of the government in 1854-56. In 1868 his name was put forward in the Cortes as a candidate for the throne, but the proposal was unsuccessful and the closing years of his life were spent in retirement.

**ESPARTO** (Gr. *σπάρτος*; Lat. *spartum*), a grass, the *Stipa tenacissima*, growing in Spain and Africa, known to the ancients and applied by them to the manufacture of cordage, matting, etc., and still more extensively used at the present day. Numerous species of *Stipa* are found in North America, chiefly in the western part. Esparto grows in tufts and bunches, like rushes, to a height of from two to four feet, and has a long flat blade, which becomes cylindrical when the ripened plant begins to dry. It is pulled up by the roots, dried in the sun and packed in bundles for exportation. Besides the various uses already indicated, esparto has for some time been applied to the manufacture of paper. Formerly the supply of esparto was almost wholly obtained from Spain, but a closely allied fibre called alfa (*Stipa arenaria*) is now obtained in still larger quantity from Algeria, while a third fibre, dis (*Festuca patula*), is imported for the same purpose from Tripoli and Tunis. See **FEATHER BUNCH-GRASS**; **FIBRE**.

**ESPATOLINO**. See **SAB** OR **ESPATOLINO**.

**ESPERANTO LANGUAGE**. "Esperanto," successor to "Volapuk" in the effort to establish an international language, has made considerable progress. The latest reports show that a substantial and lasting interest in this linguistic enterprise now exists. In 1887 Dr. Zamenhof, a Russian physician, issued his first pamphlet concerning a suggested new international language, to be called "Esperanto." Only small progress was made during the first 10 years of the movement. The idea first took root in the originator's native country. Russian educators and other men of culture looked upon the innovation with favor. After the lapse of a decade, a start was made to introduce the Zamenhof idea among the Norwegians and Swedes. They, too, showed a friendly attitude. Then France manifested great interest, and almost immediately became prominent as a stronghold of Esperantism. From France the movement extended to Germany, thence to Austria, Switzerland, Italy and England. In the latter country 30 societies of Esperantists were organized within a year of the system's introduction. During the past years, active missionary work has been undertaken in the United States looking toward the promulgation of the Zamenhof plan for use in commercial, educational and other fields. There is little doubt as to the success of the outcome, indorsed as it is by some of the greatest philologists in Germany, Austria, England, France, Russia and the United States. Advocates of an international language have in the past included numerous philosophers and scientists, including Roger Bacon, Descartes, Pascal, Leibnitz, Locke, Condillac, Voltaire, Diderot, and, more recently, Tolstoi, who unqualifiedly supported the Esperanto movement and learned its grammar rules in an hour. Only of late years have the linguistic theories of these famous thinkers been molded into anything like practical shape.

**Occasions Calling for the Use of an International Language.**—One of the principal reasons for renewal of interest in the direction of one universal language is the necessity for producing a vehicle of common expression among delegates representing various countries at congresses and on similar occasions. It has been found difficult for individuals, acting for their respective nations, to keep in touch with the proceedings from day to day. The extended use of Esperanto and the widespread appreciation manifested in its development indicates that the method of Dr. Zamenhof offers a feasible solution of what has, hitherto, been an unsolved problem. In addition to the advantages of having a common language for cosmopolitan assemblages, the transaction of voluminous mercantile affairs between nations and merchants of various nations, requires some such system to facilitate the making of purchases and adjustment of mercantile accounts. For educational purposes, as in other ways, the availability of a means whereby educators can compare systems and processes without encountering the difficulties connected with proper and complete translation is very evident.

**Present Uses of the Esperanto Language.**—From a recently published review it is learned that among the books in the Esperanto language, are translations from every known national tongue in common use, and many original novels. The number of periodicals, including national propaganda journals, scientific and official organs of various international societies, such as the Good Templars, the Free Masons, the Roman Catholics, Peace Associations, etc., printed in the international language, before the outbreak of the European War exceeded 200. Since August 1914 many of the magazines in the smaller countries—notably, Belgium, Poland, Bulgaria, Roumania, etc.—have been forced temporarily to suspend publication, although the official organs are still appearing regularly in England, France, Russia, Germany, Holland, Norway, Sweden, Italy, Spain, United States and several of the South American countries. On the continent of Europe and in the United States representative daily and weekly newspapers regularly publish articles in Esperanto, many courses of study have been furnished by the press and editorial endorsements are most frequent. Esperantist clubs and societies are operating in practically all of the European cities and have large membership. Among the most important are those of Paris, with 3,000 members, Marseilles, Lyons, Bordeaux, Havre, Lille, London, Moscow, Berlin and Dresden. The Esperanto Association of North America reports affiliated clubs in nearly all of the large cities and in many of the smaller ones in both the United States and Canada.

Several French, English and American publishers have undertaken in an extensive way to publish Esperanto works, conditional on the possession of exclusive rights, while the various national Esperanto publishing houses turn out many books annually. A library of over 5,000 volumes—constantly increasing—including textbooks, translated and original works, is now found listed in the Esperanto catalogues. Quite a number of large commercial concerns are using the system for cable and telegraphic purposes. Courses of study in Esperanto form an attractive feature in commercial schools,

clubs and public institutions, some of which make a special feature of teaching the blind to read by the new system. Several of the standard typewriters are equipped with Esperanto keyboards, and in that connection many stenographers are learning the use of the language for shorthand purposes.

In the colleges and schools, Esperanto is commanding considerable attention. One of the Esperantist triumphs was the delivery of an address in the Esperanto language by Mr. Moch, the famous peace advocate, at the International Peace Congress, Lucerne. At the Boulogne Universal Esperanto Congress, 1,200 delegates from 22 countries spoke the Esperanto language freely and understood each other thoroughly. A complete test was made by means of speeches, discussions, concerts, dramatic performances and religious services. During that congress the work of Dr. Zamenhof was officially noticed by the French government. The Minister of Public Instruction extended thanks in behalf of the president of the republic and of the people of France. In the course of the proceedings a reception was tendered to the creator of Esperanto at the Hotel de Ville, Paris. If further proof were needed that the Esperanto language is a practical spoken tongue—11 universal congresses have been scheduled—two having taken place in the United States. The largest on record was arranged for Paris, in August 1914, at which over 5,000 delegates representing every nation on the globe had already enrolled. A large majority, including a number from the United States, had arrived in Paris for the Congress week, when the declaration of war was made known—11 universal congresses have been scheduled—meeting of one of the largest and most unique international gatherings ever known. The 11th Universal Congress was held in San Francisco, August 1915, in conjunction with the Eighth National Convention of the Esperanto Association of North America. The value and use of Esperanto in the war have been attested in many ways. Striking instances of the use of the international tongue between Austrian prisoners and their Russian captors; between Russian captives of the Austrians and Germans, etc., have been made known. Esperantists have sent several fully equipped Red Cross Esperanto ambulances into the field with personnel. Esperanto is being taught in the prison and internment camps, so that there may be a common language. There is an Esperanto repatriation bureau maintained in Geneva, Switzerland, through which disrupted families are brought together, correspondence forwarded, and much other good of like nature accomplished. Statements relating to justification for the war were issued in Esperanto by governments, notably the French and German—the latter also issuing official war bulletins in Esperanto for international distribution. Keys, weighing but five grams, though containing the elements of the language and vocabulary of more than 2,000 words, are published in practically all languages, for international conversational and correspondence purposes. A similar series of Esperanto Red Cross booklets is published, and much other work is being accomplished along these lines. In short, Esperanto is proving its great value for its intended purposes and it is the best passport in warring countries that one may possess.

**Method of the Esperanto Language.**—In the general plan of Dr. Zamenhof the aim is to omit all accidental words in the language of each nation, retaining only such words as are common to all nations. Sounds peculiar to any one language are eliminated. The English *th* and *w*, appearing in English words, but not in those of the French or German languages, are, therefore, according to the rule of the originator of Esperanto, dropped. The French *u*, the German *u* and the French nasals not used in English are left out, also the Spanish *n* and *j*, and the German *ih*. The pursuance of this plan removes all difficulties as to pronunciation. Phonetic spelling is the Esperanto rule, a certain letter having the same sound always. Mute and double letters are cut out. The letter *x* becomes *ks*, *ph* becomes *f*, *ch* becomes *k* for the guttural sound, and *ŝ*—*c* remaining for the ordinary sound in words like *cigar*. The *g* is used for the guttural (*gril*, *garb*), and *ĝ* is used for the sibilant *aĝ* which is equal to *age*. New signs introduced are *ĉ* and *ĝ*. But these are for sounds already recognized. A third sign takes the place of a double letter, viz., *ŝ* for *sh* (*ŝip* equals *ship* and *ŝi* equals *she*). Further details regarding the vocabulary, prefixes and suffixes—in fact, the whole grammar—have been issued in separate form and can be readily obtained by students. It will suffice to say here that the Esperanto vocabulary is much smaller than that of any other language, containing only about 3,000 *root* words, exclusive of scientific and technical words, as compared with 32,000 in the French language, a considerably larger number in the German language, and over 100,000 in English. The simplicity of the Esperanto grammar, comprising 16 fundamental rules, with no exceptions, is quite remarkable. The majority of those who undertake the study of Esperanto, diligently, with the proper textbooks or instruction, master it in a short time. See UNIVERSAL LANGUAGE; SCIENCE OF LANGUAGE.

**ESPERSON, Pietro**, Italian jurist: b. Sassari, Sardinia, 1833. He was educated at the university of his native place and in 1860-65 was instructor in law there. In 1865 he became professor of international law at Pavia. He published 'Rapporti giuridici tra i belligeranti e i neutrali' (1865); 'La questione Anglo-Americana del "Alabama," discussa secondo i principii del diritto internazionale' (1869); 'Giurisdizione internazionale marittima' (1877); 'L'Angleterre et les capitulations dans l'île de Chypre au point de vue du droit international' (1879); 'Le legge sulla naturalizzazione in Italia' (1886); 'De' dritti di autore sulle opera dell'ingegno ne' rapporti internazionali' (1899).

**ESPINAL**, Colombia, town in the department of Tolima, about 70 miles south of the capital, Bogotá. It has industries of tobacco and pottery. Pop. about 8,000.

**ESPINAS, Alfred Victor**, *äl-frä vĕk-tör ä-spĕ-nä*, French sociologist: b. Saint Florentin, Yonne, France, 23 May 1844. After teaching philosophy in the lycées of Bastia, Chaumont, Havre and Dijon, he became successively professor of philosophy in the universities of Douai, Lille and Bordeaux and in the latter was dean of the faculty of letters 1887-90. Since 1894 he has been professor of the history of

social economy on the Chambrun foundation, in the faculty of letters of the University of Paris. Besides contributing largely to the *Revue Philosophique*, he has translated (with Ribot) Herbert Spencer's 'Psychology' (1874), and written 'Des sociétés animales' (1877-78); 'La philosophie expérimentale en Italie' (1880); 'Histoire des doctrines économiques' (1893); 'Les origines de la technologie' (1897); 'La philosophie sociale du XVIII<sup>e</sup> siècle et la révolution' (1898).

**ESPINASSE.** See L'ESPINASSE.

**ESPINASSE, Esprit Charles Marie**, French soldier: b. Castelnaudary 1815; d. Magenta 1859. He invaded the National Assembly at night and seized the quæstors which enabled Louis Napoleon to effect his *coup d'état* of 2 Dec. 1851. For this service he was made general and aide-de-camp to the emperor. He fought in the Crimean War, was Minister of the Interior in February-June 1858, and in this office presented to the chamber the "Law of Public Safety". Later he was appointed senator. He was killed at the battle of Magenta.

**ESPINEL, Vicente Martinez**, Spanish novelist and poet: b. Ronda, December 1551; d. 1624. He studied at Salamanca, was expelled from the university there in 1572, served in the army in Flanders and about 1584 returned to Spain. In 1587 he took holy orders, in 1591 was appointed chaplain at Ronda. He lost this charge through absenting himself without permission, but his musical ability secured for him the position of choirmaster at Plasencia. In 1591 appeared his 'Diversas Rimas,' which showed considerable ability. He revived the metre known as *décimas*—a stanza of 10 octosyllabic lines—and since popularly known as *espinelas*. He is said to have added a fifth string to the guitar, but this is disputed, although the evidence against it is far from conclusive. Espinel is best remembered, however, for his picaresque novel, 'Relaciones de la vida del Escudero Marcos de Obregón' (1618). This work is an autobiography with considerable embellishment. From it, all to the contrary notwithstanding, Le Sage borrowed about one-fifth of his 'Gil Blas.' Many poems of Espinel have remained unpublished owing to their licentious character. Consult Perez de Guzman's edition of 'Marcos de Obregón' (Barcelona 1881); Claretie, Leo, 'Le sage romancier' (Paris 1890).

**ESPINOSA, Aurelio Macedonio**, American educator: b. Carnero, Colo., 12 Sept. 1880. He was educated in the public schools at Veteran and Del Norte, Colo., at the University of Colorado and the University of Chicago. In 1901-02 he was assistant in Romance languages at the University of Colorado, and from 1902 to 1910 was professor of Spanish and French at the University of New Mexico. In 1910 he was appointed associate professor of Spanish at Leland Stanford University. He was founder and special collaborator of the Société Internationale de Dialectologie Romaine and is honorary member of the Chile Folklore Society. He is the author of 'Metipsimus in Spanish and French' (1911); 'La cosecha humana' (Spanish trans. of Jordan's 'Human Harvest,' 1912); 'El Imperio Invisible' (Spanish trans. of Jordan's 'Unseen Empire' 1915). He

edited Echegaray's 'El gran galeoto' (1903); and 'El Poder de la impotencia' (1906); Ayalas' 'Consuelo' (1911); Sierra's 'Teatro de Ensueño' (1917); and 'Canción de Cuna' (1918); Benavente's 'El príncipe que todo lo aprendió en los libros' (1918); with C. G. Allen, 'Elementary Spanish Grammar' (10 eds., 1915-17); 'Elementary Spanish Reader' (1916); 'Advanced Spanish Composition and Conversation' (1917); Radin's 'Folklore de Oaxaca' (1916). He is a frequent contributor to the *Revue Hispanique*, *Journal of American Folklore*, *Revista Ilustrada*, *Revista Positiva*, the *Monitor*, etc.

**ESPIONAGE ACT OF 1917.** When the United States entered the European War in 1917 it immediately became apparent that extraordinary legislation was needed to keep in check treasonous action by certain citizens, but more especially by sympathizers with the enemy, resident in the country. To this end the Espionage Act was passed, 15 June 1917. The first provision was that whoever was in any way instrumental in the gathering of information, pictures, sketches, etc., on government property with the intent of using them in a way detrimental to the interests of the United States was liable to a fine of \$10,000 and to imprisonment for two years. This was, of course, designed to check enemy aliens who had access to navy yards, wireless stations or places where construction work was going on. The transmission of such information to a foreign country, or its representative, in time of war, was made punishable by death, or 30 years' imprisonment, and this applied to any sort of information that might be useful to an enemy. The circulation of false reports for the purpose of causing insubordination, disloyalty, mutiny, etc., including obstruction of enlistment, was made punishable by not over \$10,000 fine and 20 years' imprisonment. Conspiracy with a view to doing any of these things carried the same punishment to all conspirators, whether or not the things were accomplished. The harboring or concealing of any one guilty of such treasonable offense involved a possible fine of \$10,000 and two years' imprisonment.

The Espionage Act also gave power to the President, in case of emergency, to regulate the anchorage and movements of vessels in United States waters, and provided not over \$10,000 fine and two years' imprisonment for any one failing to comply with or interfering with the carrying out of such regulations. A similar provision was made with reference to the harboring of enemies on vessels in United States waters. The injury of vessels engaged in foreign commerce, as by setting fire to them or placing bombs, carried a fine not exceeding \$10,000 and 20 years' imprisonment. Any other form of violent obstruction of exportation called for not over \$10,000 fine and 10 years' imprisonment.

For the enforcement of neutrality the Espionage Act carried a long list of prohibitions. On reasonable cause any vessel might be detained in port, to prevent the unlawful shipment of supplies or dispatches. The sending out of armed vessels without permission was strictly prohibited. Very careful regulations were made to prevent any sending of goods where they might be transhipped to an enemy,

and statements had to be filed with the collector of customs to aid in carrying out such orders. The taking of a vessel out of port in violation of the rules laid down involved a fine of not over \$10,000, plus five years' imprisonment, and forfeiture of the vessel and goods. Any interned alien escaping or attempting to escape was liable to \$1,000 fine and a year in prison. Being engaged in any unauthorized or filibustering military expedition carried a possible fine of \$3,000 and three years in prison. The President was authorized to use the army or navy as necessary to carry out any of the provisions specified.

The seizure of arms and other articles intended for export was provided for, and the same forfeited to the United States, and the method of trying such a case before a competent court was set forth. The President was also given power, during the war, to declare certain exports unlawful, such as in his discretion might be harmful to the United States, and the penalty was placed at not over \$10,000 fine and two years in jail. Directors and officials of transportation companies were made personally liable. The disturbance of foreign relations was provided against by making criminal any harmful statements to or about foreign officials, under certain conditions, or the impersonation of a foreign official, or the acting as an agent of a foreign government except as a regularly appointed consul or attaché, was punishable. Conspiracy in this country to destroy property in a foreign country was covered under this clause, and carried not over five years' imprisonment and \$5,000 fine. All abuses of the passport privilege were severely dealt with. The counterfeiting of the government seal, or mutilation or alteration of any document bearing such seal, involved a possible \$5,000 fine and 10 years' imprisonment.

The act included a very long section as to the issuing of search warrants. This permitted judges of District Courts as well as of State and Territorial courts to issue search warrants for either property or papers embezzled contrary to a law of the United States. Probable cause had to be shown, supported by affidavits, the rights of citizens being carefully protected, but when the warrant was issued and in the hands of the proper officer he had the right to break and enter as might be necessary to carry out the search. Such officer had to give a receipt and inventory of the property so taken, under oath, and a copy must be placed with the person from whom the property or papers were taken. Restoration of the property in case of error was provided for. Obstruction of such search warrant officers in their duty involved a fine of not over \$1,000 and a year's imprisonment.

The use of the mails was prohibited for any papers, etc., in violations of the provisions of the Espionage Act, but only a search warrant authorized the opening of a sealed letter addressed to another. All treasonable matter was declared non-mailable, and the mailing or attempting to mail such carried a possible fine of \$5,000 and five years' imprisonment.

The Espionage Act was framed so as to include not only the United States proper but all its territories, as the Philippine Islands and the Canal Zone, and all its waters, continental or

insular. The act is a document of over 10,000 words, under 13 titles, and was modeled more or less on the experiences of Great Britain in dealing with the same sort of difficulties during the earlier years of the war. It proved quite effective in checking the evils at which it was aimed, and after the first year of the war there was very little enemy activity in the United States and all surreptitious treason was effectively stamped out except, of course, that which occurred sporadically and not as the result of organized bands of conspirators.

**ESPINOSA, Gaspar de**, Spanish soldier: b. Medina del Campo, about 1484; d. 1537. He studied law and entered into practice in Spain. In 1514 he came to America with Pedrarias Dávila and was made chief justice at Darien. He presided over the tribunal which condemned Balboa to death, but only passed sentence on the latter at the express command of Dávila. He resigned his judicial office and led several expeditions against the aborigines, whom he treated most inhumanely. He founded Panama in 1518, returned to Spain a few years afterward and was sent out soon again as a Crown officer in Santo Domingo. He backed Pizarro in his second expedition against Peru and accompanied him to the latter country, where he died at Cuzco.

**ESPIRITO-SANTO**, *ēs-pē'rē too-sān'tō*, Brazil, a state bounded on the north by the state of Bahia, on the east by the Atlantic Ocean, on the south and west by the states of Rio de Janeiro and Minas Geraes. Area 17,312 square miles. The coast lands are swampy, but in the interior mountains rise to a height of 7,000 feet; the highest of these, Mestre Alvares, is one of the most conspicuous landmarks on the Brazilian coast. The temperature, which is tropical, is moderated by the state's proximity to the sea. The state has immense forests, and is noted for the valuable woods found in them and the rare drugs which are distilled. The Doce River flows through some of the richest of the hinterlands, but is navigable only for very small craft. São Matheus, in the northern part of the state, is surrounded by coffee and mandioca plantations, the products of which are shipped from this port, officially known as Conceição de Barra. A number of small ports intervene between the Doce River and the spacious bay of Espirito-Santo, which has given its name to the state. Coffee, the chief agricultural product, is largely exported. Other exports are sugar, tobacco, cotton, cocoa, hides and skins, and woods. There are valuable marble deposits, which are not mined. A railway is being built to connect Ouro Preto, on the upper waters of the Doce, with the coast. Cotton goods are manufactured in the town of Pessanha. The population of the state, which was 135,997 in 1890, increased to 430,000 in 1913, this growth being due to European immigration. A few years ago the city of Victoria (pop. 15,000) had almost no maritime trade, as its port was too shallow to admit large vessels. Recently improvements have been made in the harbor, which now accommodates transatlantic steamers, and both trade and immigrants have sought it. It was first visited by the Portuguese in 1535. Colonies of Germans, Poles, Swedes, Tyrolese, Portuguese and Italians are established near Anchieta, Alfredo Chaves, Ita-

pemirim and Cachoeiro — chiefly in the southern part of the state. Some of these colonies are under government protection, receiving annual subsidies of seed and cattle; but the majority of the colonists already own lands which they work without government aid. Education, though well subsidized by the government, is, so far as the native population is concerned, in a very backward condition. The state returns four representatives to the Chamber of Deputies.

**ESPLANADE**, *ēs-plā-nād'*, in fortification, the wide open space left between a citadel and the nearest house of the city, to prevent an enemy from being able to assail it under cover of these houses. The term is also frequently applied to a kind of terrace, especially along the seaside, for public walks or drives and also to a wide city street.

**ESPOUSAL (SPONSALIA)**, or **BETROTHAL**, according to Church law consists of a deliberate mutual promise of marriage, expressed by outward signs, between two persons, both of whom may lawfully and validly enter into such an engagement. When such promise is made and accepted on both sides, neither party can lawfully withdraw from it without the other's consent or unless something occurs or some circumstance comes to light which, had it been known in time, would have hindered the engagement. Formerly such engagements used to be made with some solemnity *coram ecclesia* or at least in presence of witnesses; now they are usually made without ceremony or publicity. See MARRIAGE. Consult Mielziner, 'The Jewish Law of Marriage and Divorce' (Cincinnati 1884).

**ESPRIT DES LOIS**. See SPIRIT OF THE LAWS.

**ESPRITS FORTS** (bold spirits), the name of the French school of writers better known as freethinkers, which included D'Alembert, Diderot, Helvetius and Voltaire. This school aimed not to establish general toleration for all forms of speculation, but sought to improve their own views of religion and philosophy. They recognized pure reason as the only dependable guide; their motto might have been "L'esprit prime tout" (Intellect is supreme). They had a wide influence on their time, and their doctrines have borne fruit ever since, the quality varying greatly among the different races and peoples. Their extreme radicalism may be said to have paved the way to socialism; while their less radical principles have helped build the democracies of our day.

**ESPRONCEDA, José de**, Spanish poet: b. Almendralejo, (Badajoz) 1810; d. Madrid, 23 May 1842. His father was a colonel of cavalry, and the boy was born in the army for his mother insisted on following her husband during his campaigns. At the close of the war young Espronceda was put into school in Madrid; and there he soon distinguished himself by his precocity, his love of poetry, his enthusiasm and his good literary taste. At the age of 14 he was already known as a poet of great promise. He was filled with democratic and revolutionary ideas; and he was arrested for his boldly advocated ideas in his 15th year, and confined in a convent in Guadalajara, where his parents were then living. There he began the composition of his celebrated poem 'El

Pelayo.' On his liberation from prison he went to Madrid; but feeling that his every movement was watched by agents of the government, he went to Gibraltar, and from there to Lisbon, London and Paris. Later he fought in the revolutionary ranks in Paris (1830). He then joined an expedition sent to help Poland. After long wandering and exile from home, often with the most limited means of subsistence, he finally took advantage of the act of amnesty of 1833 and returned to Spain. There he might have lived in peace and followed his poetical inclinations, but his revolutionary bent kept him in constant trouble. Through family influence he obtained a commission in the Queen's Guards (1833); but he was soon dismissed from the army and again forced into exile, on account of his interference in politics. The following year he was permitted to return to Madrid, where he again plunged into militant politics, and into the insurrectionary movements of 1835-36. From this on he became the most ardent of the Spanish advocates of republicanism; and in 1840 his was the most listened to voice in revolutionary Spain. In December 1841 he was sent as secretary of legation to The Hague by the Republicans who had secured possession of the government, a position he retained a very short time because of his election as deputy for Almería. Already ill from his residence in the damp and cold climate of Holland, he hastened back to Madrid only to die of a severe inflammation of the throat.

Espronceda is the greatest of the passionate, patriotic poets of Spain. With him patriotism was a passion and hatred of autocracy an obsession which mastered him. There is no more passionate and compelling voice in all Spanish literature than his. He runs all the gamut of feeling; love of the most passionate kind; the fiercest hatred of oppression and injustice; the deepest patriotism, expressed in the most compelling words; the wildest visionary delight in socialism; the passion of great aspirations and pure and noble purpose; and the depths of despair of atheism and of vanished hopes and disappointed aspirations. On account of his vivacity, his burning imagery, his wonderful power of word painting, his simple direct methods in literature and his ever youthful mind, Espronceda has been called in Spain "the poet of youth and of democracy." No other writer in Spanish literature or Spanish life had, at his age, at his death (32), such a hold over his followers and admirers as José Espronceda. His companion and fellow poet, Enrique Gil, who paid his last poetic tribute to him at the graveside, broke down and sobbed like a child; and many an eye was wet among the mourners for the bright particular light of democracy that had just been extinguished in Spain. No definitive edition of Espronceda's works has been published for the reason that his efforts were spread over such a wide field of endeavor, and his writings appeared in newspapers, journals, reviews and pamphlets. Yet numerous editions of the best known of his literary productions have been issued in Spain and in several foreign countries. In these editions the following works appear: 'El Palayo'; 'Don Sancho Saldaña' (1834); 'El Estudiante de Salamanca'; the drama 'Ni el Tío ni el Sobrino,' written in collaboration with Antonio Ros de

Olano (1834); many short poems of a social, political, reflective or amatory nature; 'El Diablo Mundo' (1841); and many of the best lyrics in the Spanish language. His literary work has the form of Hugo and the spirit of Byron with an originality that is Espronceda's alone. The first edition of his collected writings appeared in Paris in 1840, the second in Madrid in 1846; and the Hartzbusch edition, with a biography by Ferrer del Rio, in Paris two years later. A more complete edition than any of these was published by Espronceda's only daughter, Blanche Espronceda de Escosura in 1874. A fairly complete edition of his poetical works also appeared in Barcelona in 1883. See *EL ESTUDIANTE DE SALAMANCA*.

**ESPY, James Pollard**, American meteorologist, the founder of modern meteorology: b. Washington County, Pa., 9 May 1785; d. Cincinnati, 24 Jan. 1860. He was graduated at Transylvania University 1808. The name "storm-king" was given to him for his originating a theory of storms which involved him in much controversy. He studied law at Xenia, Ohio, and was principal of the academy at Cumberland, Md., for five years (1812-17). From there he went to the Franklin Institute, Philadelphia, as professor of classical languages (1817-53). In 1836 he won the Magellanic prize for an essay on the theory of storms; and four years later he visited England and France where he explained at length his storm theories before the chief scientific societies of both countries. On his return home he was appointed by the United States Congress meteorologist to the War Department, and later to the Navy Department also. His 'Philosophy of Storms' which was published in 1841 gained him a great reputation in his special field. His meteorological doctrine on the point of how atmospheric disturbances commence was approved by the French Academy, but his views as to the mechanics of storm are contrary to received fact, and have been exploded. His principal contribution to practical meteorology was his institution of a system of telegraphic weather bulletins, which should converge at the capital and give daily intelligence of the weather in different widely separated points, and it may be justly claimed that he thus laid the foundation of all sound theory on the subject of weather prediction. Consult *Monthly Weather Review* (Vol. XXXV, Washington 1907); and *Appleton's Popular Science Monthly* (April 1889).

**ESQUILACHE, Don Francisco de Borja y Aragón, Príncipe de** (FRANCISCO DE BORJA Y ACEVEDO), Spanish poet: b. Madrid, about 1581; d. there 1658. From 1614 to 1621 he was viceroy of Peru, after which he returned to Spain and lived at the court of Madrid. He wrote 'La pasión de Nuestro Señor,' a sacred poem (1638); 'Nápoles recuperada,' celebrating the conquest of Naples (1651); a translation of Thomas à Kempis (1661), and many poems. Selections of his works are included in 'Biblioteca de Autores Españoles.'

**ESQUILINE HILL** (*mons Esquilinus*), the highest of the seven hills of Rome. It is between the Viminal and the Cælian hills, is 246 feet in height and under Augustus was laid out in pleasure gardens, known as the Gardens

of Mæcenas. Soon after it was the fashionable residential section of the city. Virgil, Horace, Mæcenas and Propertius are the most celebrated of its residents at this period. The baths of Titus and Nero's golden palace were on the Esquilinus and many of the ruins have been uncovered only to be at once destroyed in the course of erecting new buildings. In the modern city the Esquiline is a new modern portion with fine streets and buildings. Consult Platner, 'The Topography and Monuments of Ancient Rome' (2d ed., New York 1911).

**ESQUIMALT**, ɛs-kwɪ'mält, Canada, naval base in British Columbia, on the southeast coast of Vancouver Island, and on the Strait of San Juan de Fuca and the Esquimalt and Nanaimo Railway, four miles from Victoria. The harbor is extensive and capable of receiving vessels of the greatest size, and was the British navy station for this part of the Pacific coast. It has a navy yard, and a large dry dock built in 1888. The defenses were greatly strengthened by the British government, and a British garrison was stationed here until in 1905, on the Canadian government undertaking to look to the defenses of Canada, it was withdrawn. The drydock was transferred to the Canadian government in 1910.

**ESQUIMAUX**. See ESKIMO.

**ESQUIRE**, ɛskwɪr, old French; *escudero*, Spanish; a shield-bearer or armor-bearer, an attendant on a knight; hence, in modern times a title of dignity next in degree below a knight. In Great Britain this title is given properly to the younger sons of noblemen, to officers of the king's courts, and of the household, to counsellors at law, justices of the peace while in commission, sheriffs, gentlemen who have held commissions in the army and navy, and in fact to anyone save tradesmen, mechanics and peasants. It is usually given to all professional and literary men, both there and in the United States. In heraldry the helmet of an esquire is represented sideways with the visor closed. The title, however, no longer exists as a creation of letters patent.

**ESQUIROL**, Jean Etienne Dominique, zhɔ̃n ɛ-tɛ-ɛ̃n dɔ-mɛ-nɛk ɛs-kɛ-rɔ̃l, French physician: b. Toulouse, 4 Jan. 1772; d. 12 Dec. 1840. His life was chiefly given to improving the methods of treating the insane, and he contributed greatly toward the abolition of the barbarous methods so long in vogue. In 1799 he founded a model asylum at Paris; visited all the asylums in France 1808; was appointed physician to the Salpêtrière 1811; and in 1826 became head of the private asylum at Charenton, which he had largely planned. In 1817 his public revelations of the abuses current in French asylums led the government to appoint an investigating commission. His studies included the architecture and construction of asylums, and the best of the earlier 19th century buildings for the insane in France, such as those at Rouen, Nantes and Montpellier, were built in accordance with his plans and instructions. He wrote 'Des Illusions chez les Aliénés' (1832; English trans. 1833); 'Des maladies mentales' (1838); and articles in the 'Dictionnaire des sciences médicales,' and the 'Encyclopédie des genres du monde.'

**ESQUIROS**, Henri François Alphonse, ɔ̃n-rɛ frãñ-swã ɛl-fɔ̃ns ɛs-kɛ-rɔ̃s, French poet and miscellaneous writer: b. Paris, 23 May 1812; d. Versailles, 12 May 1876. His first work, a volume of poetry, 'Les Hirondelles,' appeared in 1834. This was followed by numerous romances, and a socialistic commentary on the life of Christ, 'L'Évangile du peuple' (1840), for which he was prosecuted and imprisoned, and 'Charlotte Corday' (1840). He then published 'Les chants d'un prisonnier' (1841), poems written in prison; 'Les vierges folles' (1842); 'Les vierges sages' (1842); 'L'histoire des Montagnards' (1847). Having to leave France in 1851, he resided for years in England, and wrote a series of essays for the '*Revue des Deux Mondes*' on English life and character, which were translated under the title of 'The English at Home,' and were very popular. He also wrote a similar work on the Dutch. Other works of his are 'Le droit au travail' (1849); 'La vie future au point de vue socialiste' (1857); 'Histoire des martyrs de la liberté' (1851); 'La Morale Universelle' (1859); 'Religious Life in England' (1867, published in English); 'Les paysans' (1877); 'Le château enchanté' (1877), a novel.

**ESQUIVEL**, Juan de, hoo-ɛn' dɛ ɛs-kɛ-vɛl, Spanish soldier: b. 1470; d. 1519. He was the companion of Ovando when the latter went to Hispaniola to succeed Bobadilla as governor. Ovando sent him as leader of an armed expedition against the uprising of the native chief, Cotabanamá, in Higüey province in 1504. In 1509, at the instance of Diego Columbus, he conquered the island of Jamaica and settled it as a Spanish possession. The colony flourished under his administration, and he founded there the city of Sevilla Nueva.

**ESS**, Johann Heinrich von, yɔ̃-hãn hɪn'rɪh fãn ɛs (better known by his Benedictine name 'LEANDER'), German theologian: b. Warburg, 15 Feb. 1772; d. Affolderbach in the Odenwald, 13 Oct. 1847. He entered the Benedictine abbey of Marienmünster as a novice 1790; was pastor at Schwalenberg 1799-1812; and professor of theology at the seminary in Marburg 1812-22. In 1807, with his cousin Karl, he published a German translation of the New Testament, the circulation of which was forbidden by the Pope. The following year he published a defense of his views as to Bible reading by the people, a new edition of which was issued in 1816 entitled 'Gedanken über Bibel und Bibellehre.' After 1822 he gave his whole time to circulating his Bible versions among the people, to spreading his doctrines and to the composition of a German version of the entire Scriptures, which he finished in 1840. Others of his publications are 'Was War die Bibel den Ersten Christen?' (1816); 'Die Bibel Nicht ein Buch für Priester' (1818); an edition of the Vulgate (Tübingen 1822-24); of the Septuagint (1824; new ed. 1887) and of the Greek New Testament (1827).

**ESSAAD EFFENDI**, Mohammed, Turk- ish historian: b. Constantinople, 1790; d. 1848. He was appointed historiographer of the empire, editor of the official state journal, and for some time served also as Ambassador to Persia. Caussin de Perceval published some of his work under the title, 'Précis historique de

la destruction du corps des Janissaires' (Paris 1833).

**ESSAD, Pasha**, Albanian soldier and adventurer: b. about 1865. The descendant of a powerful and wealthy family—the Topdani—who maintain to this day a sort of feudal authority and splendor, Essad began his varied career in the Turkish army. His elder brother, Ghani, became a secret instrument of Abdul Hamid II for the noiseless removal of obnoxious personages. A relative of one of his victims murdered Ghani, and was in turn shot down by Essad on Galata bridge in broad daylight. Combining the profession of a bandit chief with that of a soldier, Essad Pasha had at all times a host of Albanian clansmen at his command. He espoused the cause of the Young Turks in 1908 and, after the revival of the constitution, was sent to Constantinople as a deputy from Durazzo, the Albanian capital. It was Essad Pasha who announced to the sultan that the committee had decided to depose him. On the outbreak of the Balkan Wars (q.v.) he was appointed commander-in-chief to defend Albania with some 18,000 troops. With the garrison of Janina he defended that place for three months when he surrendered to the Greeks with 30,000 men on 6 March 1913; six weeks later he surrendered Scutari to the Montenegrins. It appears that Essad Pasha cherished ambitions to create Albania an independent state with himself as ruler, and there were strong grounds to believe that the two capitulations—of Janina and Scutar.—were the price he paid for eventual recognition, in addition to which he received a handsome fee from Russia. The selection by the powers of Prince William of Wied to be king of Albania nullified the hopes of Essad Pasha, who now became Minister of War under the new régime. Before long, however, he was fomenting an insurrection and was deported. The king of Albania had soon to flee from the country himself, and Essad Pasha, under Italian protection, returned to Durazzo in October 1914 in the rôle of dictator. He was elected president of the Albanian provisional government. He dismissed the Austrian Minister—whose government had supported the claims of Ismail Kemal Bey for the kingship—and strengthened the remnants of the Serbian army with his own forces against the Austrians and Bulgarians. In 1916 it was reported that Essad Pasha had fled to Italy.

**ESSAY.** The term essay is used in various loosely defined ways, but usually describes a brief prose composition of an expository character. Originally and properly, the word implies a tentative and suggestive, as distinguished from a formal and complete, discussion; and this use is applicable to the "familiar" essay, the most purely literary of all the types. Dr. Samuel Johnson, from the same standpoint, defined the essay as "a loose sally of the mind, an irregular, indigested piece." On the other hand, the term is equally applicable, in modern use, to formal expository compositions, and has even been extended to cover treatises of an extensive character, as Locke's 'Essay Concerning Human Understanding' (1690). In the 18th century it was also extended to compositions in verse, notably Pope's 'Essay on Man' 1734. Essays are sometimes classified, for con-

venience, as (1) gnomic or aphoristic, (2) personal or familiar, and (3) critical or didactic. The first type, which may be regarded as the original or primitive, represents the making of an essay by the process of bringing together gnomic sayings or aphorisms having to do with the same subject,—a process well exemplified by certain portions of the biblical book of Proverbs. Thus, while the greater part of that book is made up of brief separate proverbs or epigrams, these are developed into what may well be called essays in such passages as the account of Wisdom (chap. 1, verses 20–33) or of the Virtuous Woman (chap. 31, 10–31). The second type represents the treatment of a particular subject from a distinctively individual standpoint, and at times reaches a point of development closely analogous to the personal lyric in poetry. The third type represents a more utilitarian purpose, and has been most fruitfully developed in the pursuit of literary criticism. But the several types are not infrequently blended, and others might well enough be added if the classification were made complete.

In ancient classical literature the essay was not a recognized literary form; its functions may be said to have been accomplished largely by the epistle and the dialogue. Thus Bacon said that "Seneca's epistles to Lucilius, if one mark them well, are but essays"; and one might say that certain of Plato's Dialogues mark the highest reach of the method of the essay in any language. To a later philosopher, Theophrastus, were attributed the "Ethical Characters," descriptive of various character types, which we shall see gave rise in modern times to a kind of essay form. The closest approach in antiquity, however, to what we now call the essay is to be found in the late Greek period, when the biographer and philosopher Plutarch (1st century A.D.) wrote a number of compositions, traditionally called *Opera Moralia* (Moral Works), on such subjects as "The Right Way of Listening," "How a Flatterer may be Distinguished from a Friend," "On Chance," "On Superstition," and "On Exile." Analogous to these writings, in Latin literature, are the partly philosophic, partly personal 'Tusculan Disputations' of Cicero, the epistles and other moral disquisitions of Seneca, and—closest to the essay in their informal discursiveness—the 'Meditations' of the Emperor Marcus Aurelius. Some influence on later types of essay literature may also be traced to the miscellanies— anecdotal and otherwise—of Valerius Maximus and Aulus Gellius; the work of the former is called 'Books of Memorable Deeds and Utterances,' that of the latter 'Attic Nights.'

In the mediæval period the essay cannot be recognized as a separate type; some approximation to it may be noted in the successors of the miscellanies just mentioned, and in various collections of wise sayings ("sententiæ" or sentences). In particular, writers in the service of the Church made a practice of bringing together incidents and utterances illustrative of particular virtues, vices and spiritual truths, which, though they were more likely to develop into homily or sermon than into essay, sometimes furnished method or materials for later essayists. In France the form called Moral Lesson (*leçon morale*) has been thought



to form a link between these mediæval writings and the essays of Montaigne.

The modern conception of the essay as a distinct literary form, and the use of the word "essay" to describe it, have their origin with definiteness in the work of Montaigne, who in 1580 published a volume of *essais* at Bordeaux; a second edition, with important additions, followed in 1588. A considerable portion of these essays of Montaigne is in the classical and mediæval tradition,—discourse on moral themes, illustrated with anecdotes and aphorisms collected from a wide range of reading. But from this type of essay Montaigne developed the more personal type, discoursing on whatever subject came to hand from the standpoint of his individual experience and mood; so that he could say in his address "to the reader": I have no respect or consideration at all either to thy service or to my glory. . . . Myself am the groundwork of my book. It is then no reason thou shouldst employ thy time about so frivolous and vain a subject." To this sort of mood, and the essays that represent it, the whole later development of the "familiar" essay is universally traced.

Montaigne's essays were translated and widely read in England, and the new form became more important across the Channel than in its native land. In 1597 Francis Bacon borrowed the name Essay for a little collection which bore the subtitle 'Religious Meditations',—only 10 in all; in the edition of 1612 the number was increased to 38, in that of 1625 to 58. This collection also became popular, and has remained a classic; but Bacon held rather to the older tradition of the aphoristic essay than to the newer type of Montaigne. In his later writings he gives more unity, and sometimes more personality, to the form, yet never to the point of becoming "familiar."

Sir William Cornwallis, a contemporary of Bacon's, followed his work with a succession of essays on moral themes (1600, 1610, etc.). The chief successors of Bacon and Cornwallis, in the 17th century, were Felltham (who called his essays *Resolves*, about 1620), Cowley (who included 11 essays in his collected works of 1668), and Sir William Temple ('Miscellanea,' 1680, etc.). In the Restoration period Dryden may be said to have originated the modern critical essay, in the various prefaces on literary subjects which he was fond of prefixing to his writings. He also revived the dialogue form for the same purpose, in his 'Essay of Dramatic Poesy' (1667). Near the close of the century Defoe began to develop the essay form for the discussion of social, political and educational questions, notably in the 'Essay on Projects' (1697). One may also note two other literary types which, going back to much earlier periods, were highly valued in the 17th century and contributed to the art of the essay. The first of these is the "character," originated, as has been mentioned, by the Greek, Theophrastus, whose quasi-essays were now revived and imitated in both England and France,—notably by Joseph Hall ('Characters of Vices and Virtues,' 1608), John Earle ('Microcosmographie, or a Piece of the World Discovered in Essays and Characters,' 1628), and Jean La Bruvère ('Les caracteres, ou les mœurs de ce siècle,' 1688). The second type is the epistle, also, as we have seen, of long-standing

importance, and newly cultivated in the Renaissance and the succeeding age; notable examples of the development of this form in the direction of the literary essay are the Spanish letters of Guevara (d. 1545), which were translated into English more than once, and came to be called the "Golden Epistles"; the French letters of Jean de Balzac (1624); and James Howell's 'Epistolæ Ho-Elianzæ, Familiar Letters Domestic and Foreign' (1645-55). Finally, for the 17th century, it should be observed that the 'Religio Medici' (1642) and 'Urn Burial' (1658) of Sir Thomas Browne exemplify some of the most delightful qualities of the familiar essay, in expanded form, though not called by that name.

The early 18th century saw a highly important development of the essay in connection with the growth of periodical literature. The beginnings of this movement may be observed in the work of Defoe and even earlier, but its first conspicuous representatives were Steele and Addison, in the several periodicals which they issued singly or jointly; indeed one might say that the new periodical essay was born in Steele's *Tatler*, which began to appear in 1709. Addison presently became Steele's coadjutor, and in the *Spectator*, begun March 1711, his influence was paramount. The type of essay developed in these periodicals was of fairly fixed length, suited to reading at the breakfast table, and combined in an important way the qualities of the familiar, and didactic essay: that is, its purpose was the serious and profitable discussion of social, ethical and literary topics, but the point of view was distinctly personal, being represented as that of a sagacious but whimsical character, named "Mr. Bickerstaff" in the earlier periodical and simply "The Spectator" in the later. The influence of these periodical essays of Addison and Steele can scarcely be exaggerated, and it persisted throughout the century, not only in England but on the continent. More than 200 English journals or essay-series of the *Spectator* type have been counted for the century 1709-1809, and in France, Germany, Italy and even Russia it was also imitated. In France Marivaux first wrote Addisonian essays for the *Mercur*, then (1722) issued a *Spectateur Français*. In Zürich appeared the *Discourse der Maler* (1721), essays written by the members of a club headed by Johann Bodmer, under pen-names adopted from famous artists; in Hamburg an essay-periodical called *Der Patriot* appeared in 1724, and at Leipzig in 1725 Gottsched's *Vernünftige Tadelninnen* ("Sensible Fault-finders"). In the direction of literary criticism perhaps the finest results of the movement in Germany are to be found in certain essays of Lessing's, such as the series called *Litteraturbriefe* (1759-65) and the *Dramaturgie* (1767-69). In England the most distinguished successors of Steele and Addison were Dr. Samuel Johnson, who issued *The Rambler* in 1750-52 and later wrote various series of essays for other periodicals, and Oliver Goldsmith, who contributed essays to *The Bee*, *The Public Ledger*, etc. (1759-61). Goldsmith's work in the combined familiar and didactic essay is the only rival of the *Spectator* at its best, whether in charm of manner or quality of substance; in particular, he developed skilfully, in a series of essays called *The Citizen of the*

*World*, an amusing method of commenting on contemporary life from the assumed standpoint of a foreigner, which had been availed of by earlier critics, notably Montesquieu in the *Lettres Persanes* (1721).

The development of the essay in the early 19th century was again due largely to the evolution of periodical types, and in English literature one distinguishes clearly two of these types, the magazine and the critical review, which gave new opportunity for the familiar and the critical essay respectively. Most important of the former were *Blackwood's* and the *London Magazine*, founded in 1817 and 1820; of *Blackwood's* John Wilson ("Christopher North") soon became the leading essayist, while the *London Magazine* had the distinction of printing some of the most brilliant work of Lamb, DeQuincey and Hazlitt. The brothers John and Leigh Hunt were also concerned in the publication of a number of periodicals, some (like the *Examiner*) being of a newspaper type, but offering space for literary essays, others (like the *Indicator*) continuing the *Spectator* tradition. For all these Leigh Hunt was a leading writer,—with the possible exception of John Wilson, the most prolific of the 19th century essayists. The Elia essays of Charles Lamb, which appeared in the *London Magazine* 1820–25, are by universal consent the finest examples of the familiar type produced since Montaigne's; some of Hazlitt's, however (to be found in his collections called *The Round Table*, 1817, and *Table Talk*, 1822), are not far beneath them, and of substantial literary criticism (as in the papers called *Characters of Shakespeare's Plays*, 1817) Hazlitt gives us far more than Lamb. Of the second newly developed type of periodical, the critical, the leading representatives are the *Edinburgh Review* and the *Quarterly Review*, founded in 1802 and 1809 respectively; these gave rise to a new form of literary essay, called a "review," which normally took its origin in an account of some recent publications, but became an independent discussion of the subject suggested by the work in hand. The typical examples of this form are to be found in the essays of Francis Jeffrey, long editor of the *Edinburgh*, and John Gibson Lockhart, long editor of the *Quarterly*; but their work, important as it seemed, has proved insignificant in comparison with that of Thomas Babington Macaulay, who began his career as reviewer in the *Edinburgh* with his famous article on Milton, 1825, and remains the most brilliant and prolific of English critical essayists.

We cannot here follow the course of the essay throughout the 19th century. In general, England has continued to produce the most distinguished work in the familiar type; its best representative in recent times was Robert Louis Stevenson ('Familiar Studies,' 1882, and 'Memories and Portraits,' 1887). English writers have also done fine work in the critical essay, notably Matthew Arnold ('Essays in Criticism,' 1865, 1888) and Leslie Stephen ('Hours in a Library,' 1874–79); but here the palm must be yielded to the French, who have used the essay most characteristically for this purpose, notably Sainte-Beuve ('Causeries du Lundi,' 1851–72), Brunetière ('Questions de Critique,' 1889), and Anatole France ('La Vie

Littéraire,' 1907). American literature includes, for the early period, one notable representative of the Addison tradition, Washington Irving ('Sketch Book,' 1820). By far the most distinguished American essayist is Emerson, who revived to some extent the method of the aphoristic essay, emphasizing the single utterance rather more than the whole composition ('Essays,' 1841–44). In the critical type the work of James Russell Lowell remains unexcelled ('Among my Books,' 1870–76). Other noteworthy American essayists of the 19th century are E. P. Whipple, Edgar A. Poe, Donald G. Mitchell ("Ik Marvel"), Thomas Wentworth Higginson, George William Curtis and Charles Dudley Warner. In the 'Autocrat of the Breakfast Table' (1858), Oliver Wendell Holmes made wise and witty use of the method of the familiar essay, though in an expanded and discursive form which belongs to no definite type.

**Bibliography.**—The best account of the familiar essay is to be found in the introduction to Bryan and Crane's collection called 'The English Familiar Essay' (Boston 1916). For the English essay as a whole, consult Walker's 'The English Essay and Essayists' (London 1915); MacDonald, W. L., 'Beginnings of the English Essay' (University of Toronto Studies); Wylie, Laura T., 'The English Essay' (in *Social Studies in English Literature*, Boston 1916). For the reviews and the critical essay, consult the introductions to Gates's 'Selections from the Essays of Jeffrey' (Boston 1894), and Haney's 'Early Reviews of English Poets' (Philadelphia 1904); also Saintsbury's 'History of Criticism' (Edinburgh 1904). For the character-writers, consult Morley's 'Character Writings of the 17th Century' (London 1891); for the letter-writers, Hansche's 'English Familiar Letter-writers and their Contribution to the English Essay' (Dissertation of the University of Pennsylvania, 1902). For the *Spectator* and its influence, consult Beljame's 'Le public et les hommes de lettres en Angleterre au 18e siècle' (Paris 1881). There is a convenient collection of essays by British writers in the Everyman's Library series, and a similar collection of American essays has been edited by Brander Matthews (Oxford Press 1914).

RAYMOND M. ALDEN,  
Professor of English, Leland Stanford Junior University.

**ESSAY ON CRITICISM, An**, a didactic poem in heroic couplets by Alexander Pope (q.v.) in which he explains and propounds the canons of verse structure, poetic taste and criticism. The poem, Pope's first really original work, was written either in 1707 or 1709, more likely in the latter year. It was first published anonymously on 15 May 1711 and sold so well that another impression was made the same year. The second edition, published in 1713, gave as the name of the author "Mr. Pope." Since then it has been included in practically every edition of Pope's works. The most exhaustively critical and most carefully annotated edition is that edited by J. W. Croker, W. Elwin and W. J. Courthope (London 1871–89) where it will be found in the second volume. It has been translated into Latin, French, German, Italian, Spanish,

Portuguese, Hungarian, Polish and Russian. Opinions concerning the merits of the poem are divided. In its own days it was praised very highly by such astute critics as Addison and Dr. Johnson. Of the next generation of critics, Hazlitt continues to sing its praises, but DeQuincey criticizes it harshly.

The fact remains, however, that, though metrically by far the least polished of Pope's poems, it was a remarkable performance for a youth of 21, both in regard to its poetical value and in respect to its contents. Its imagery, though very uneven, at points reaches heights which were never surpassed by the author and many of its striking passages have become familiar quotations. It is one of Pope's longer works, consisting of 744 verses, divided into three parts. With it began the long series of literary quarrels in which Pope was involved throughout his entire career as a result of his biting satire. In the 'Essay on Criticism' he attacked particularly vigorously and outspokenly a critic and playwright of that day, J. Dennis (q.v.) who replied in a pamphlet, called 'Reflections upon a late Rhapsodie, called "An Essay upon Criticism"' in which he in turn criticized very sharply and in places with considerable justice Pope's work. Consult Graner, K., "Die Übersetzungen, von Pope's Essay on Criticism," etc. (Aschaffenburg 1910). See POPE, ALEXANDER.

B. H. GOLDSMITH.

**ESSAY ON THE HUMAN UNDERSTANDING, An.** John Locke's 'Essay on the Human Understanding' is the classic of English common sense empiricism. Subsequent philosophy and psychology and English thought in general are weighted with its terminology and opinions.

Locke's purpose, so he tells us, was "to inquire into the origin, certainty and extent of human knowledge, together with the grounds and degrees of belief, opinion and assent." He would determine the powers of the understanding by an "historical" method, that is, by tracing the growth of knowledge in the individual. As a result of his analysis Locke decided that mind is conversant only with "ideas" and their relations, which ideas it acquired through sensation and through reflection on its own operations. These ideas, "whatever is the object of the mind when a man thinks," are the *copies* of things—the effects produced in us by objects. He never questioned their representative character so far as the primary qualities, such as extension, motion, etc., are concerned and considered them sufficient evidence of an external world.

Knowledge is the perception of the agreement or disagreement of ideas and arises in three degrees: intuitive, by which we perceive immediately the relation between two ideas; demonstrative, i.e., a chain of intuitions; sensitive, which gives us knowledge of particular things. The limitation thus imposed leaves outside the realm of knowledge most of the matters with which the mind is generally occupied in the conduct of life. These must be determined by probable "judgment."

Locke was very uncritical and avoided the logical extremes to which his argument is obviously subject and which are to be found in the idealism of Berkeley and the sensationalism

of Condillac. His doctrine of representative ideas as the ultimate data of knowledge clearly expresses an epistemological position which may be regarded as the fundamental principle or fundamental fallacy of subsequent philosophy, according to one's metaphysical preferences.

The 'Essay' has probably run to more editions than any other modern philosophical classic and almost every subsequent philosopher has taken it at one time or another as a topic. Leibnitz's 'Nouveaux Essais sur l'entendement humain' (1761) is a running commentary on Locke. The best critical edition is that by Prof. C. Fraser (1894).

WALTER B. VEAZIE.

**ESSAY ON MAN, The,** one of the later works (1733-34) of Alexander Pope, shares with the 'Essay on Criticism,' the 'Rape of the Lock,' the 'Dunciad,' the 'Epistle to Dr. Arbuthnot' and a few other poems the position of foremost place among his original works. It is a didactic poem of some 600 heroic couplets grouped into four epistles and dedicated to Lord Bolingbroke, with whose brilliant but somewhat trivial philosophy it is in substantial agreement. There is probably a fixed order in the universe and definite gradations among all living things, including man, but it is presumption in man to attempt to define himself and to determine his place in the universe; he can only humbly submit to the decrees of Providence. The proper study, therefore, of mankind is man, in whom the outstanding characteristic is a mixture of two principles, self-love and reason, which are expressed in varying combinations of virtue and vice, which by giving men different characters, serve the ends of Providence. Reason and self-love operate in the formation of Society, and its institutions are according to the divine purpose. This universal aim is human happiness which, though obscured by false notions of the means of attaining it, consists in the acquisition of virtue. This is the general law, which it is folly to think will be altered to suit man's desires for prosperity, honors and the many objects of ambition of men. The philosophy is not particularly moving or consistent, and the poem is to-day best remembered for the large number of familiar quotations that it has contributed to the common stock—"Whatever is, is right," "Pleased with a rattle, tickled with a straw," "Order is heaven's first law," "An honest man's the noblest work of God," "The wisest, brightest, meanest of mankind," etc. A good account is to be found in Chapter VII of Leslie Stephen's 'Pope' in the English Men of Letters.

WILLIAM T. BREWSTER.

**ESSAYS OF BACON.** Bacon's 'Essays' were practically the first things in English literature to be called by the name "Essay." That word, in the 16th century, generally carried the idea of attempt or trial and it was in some such sense that Bacon used it. In the 10 essays first published he gave, not finished treatments but rather tentative reflections. He himself calls them "certain brief notes set down rather significantly than curiously (i.e., suggestively rather than carefully), which I have called Essays." Montaigne had used practically the same word in French a few years before and almost immediately after Bacon's collection it began to be common. The essay

developed into several forms in the 17th century, but in the earlier essays there was something of the experimental, incomplete character which we do not generally have in mind when we think of the essay at present. The subject matter of Bacon's 'Essays' was also informal and familiar. His own often-quoted words are that the 'Essays' have been "the most current" of his works because "as it seems, they come home to men's business and bosoms." The 'Essays' are, in fact, the sincere and natural thoughts of a great man, not elaborately molded into a monumental work, but set down much as they may have come to his mind when he had leisure to think of the things that interested him. Bacon was a great figure in the development of philosophy and science, but it is not for such reasons that his 'Essays' have been read. The subject matter of the 'Essays' is mostly the thoughts and ideas that come to the private heart of man as he thinks of himself, of how he gets on in the world, and how he stands with eternity and with God. There is in them much that belongs especially to the private thought of Bacon, who lived the life of a courtier and a man of affairs as well as that of a scholar. But everyone finds something of interest in the 'Essays,' for they give the natural reflections of a powerful mind as it considered the things that are likely to occur to everybody. In style the 'Essays' are generally less familiar than in substance. In the matter of expression they are concise and polished, by no means the sort of thing that a man could write offhand. Though, each as a whole, they do not make complete and finished treatments, yet the separate sentences are condensed and often proverbial and seem carefully corrected, as a comparison of the different editions shows they are. The 'Essays' were first published in 1597, when 10 only appeared, dedicated to his brother. In 1612 appeared a new edition containing 38 essays, nine of them of the earlier collection. In 1625 the last edition in Bacon's life contained 19 essays more. There have been numberless editions since, among which are E. Arber's 'Harmony,' and the editions with annotation by R. Whately, W. A. Wright and J. Spedding.

EDWARD E. HALE.

#### ESSAYS FROM THE EASY CHAIR.

In 1854 George William Curtis began to write familiar and personal essays in a department of *Harper's Magazine* called "The Easy Chair." He continued to do so for the 38 remaining years of his life, writing approximately 2,500 in all. In these essays he dealt with every sort of imaginable subject—"with worthies ancient and modern, with early impressions and striking contemporary situations, with poets and novelists and orators and actors and musicians, with every aspect of the social comedy as viewed by the most genial of spectators, with all matters that seemed to lend themselves to his purpose of unobtrusive didacticism—a purpose so veiled by animated and fanciful discourse that the reader is hardly conscious of its existence." From these essays three volumes of representative essays were selected and republished after his death. They not only throw interesting side-lights upon his own life and personality, but together they constitute a series of invaluable

able incidents and interpretations of American life for nearly half a century.

Curtis has many of the characteristics of the men who from Montaigne to Stevenson have made of the personal type of essay one of the permanent and most delightful forms of literature. The light touch, personal likes and dislikes, character sketches, delicate humor and pathos, suggestive bits of wisdom, are all found in his essays. He suffers most by contrast with Lamb in his lack of felicitous literary allusion and in his failure to secure the more permanent effects of rhetoric, in the better sense of that word. He is perhaps more like Addison, or Goldsmith, or Irving, though less final in his power of expression than any of them.

A typical volume of these essays gives some idea of the range of his topics. He has reminiscences of Edward Everett, Emerson, Dickens, Thoreau, Wendell Phillips, Jenny Lind, Thackeray and Browning, each of whom is recalled in some typical lecture or conversation or dinner. The theatre figures in an account of Jefferson as Rip Van Winkle and in reminiscences of Fanny Kemble and John Gilbert. That he was fond of music is suggested in "The Opera in 1864," "Thalberg and Other Pianists" and "Cecilia Playing." Typical sketches of social life and of various aspects of New York are to be found in "Shops and Shopping," "Mrs. Grundy and the Cosmopolitan," "Easter Bonnets" and "The Town."

At the time Curtis was writing such essays for *Harper's Magazine* he was writing editorials for *Harper's Weekly* and delivering addresses throughout the country of an entirely different character. It is surprising that the man who was a leader in the movement for civil service reform, who helped to inaugurate the independent movement in American politics, and who at an earlier date took a prominent part in the organization of the Republican party, should have been able to detach himself from the stream of affairs as he did in his charming essays. In this respect, as in many others, he was like his friend James Russell Lowell, who wrote to him words that best give an interpretation of his personality:

"Had letters kept you, every wreath were yours;  
Had the world tempted, all its chariest doors  
Had swung on flattered hinges to admit  
Such high bred manners, such good natured wit."

EDWIN MORRIS.

#### ESSAYS OF ELIA.

Charles Lamb's Essays, the most famous and delightful of his works, were written in the spare hours of his busy life, and were originally published chiefly as contributions to the *London Magazine* from 1820 to 1833. The first collected volume, 'The Essays of Elia,' appeared in 1823; the second, 'Last Essays of Elia,' 10 years later. The signature Elia, which Lamb adopted from the name of a former clerk in the South Sea House where he had been employed, served as a thin disguise, under the cover of which the author revealed in an intimate way his own experiences and thoughts, distorting the actual facts of his life only so much as was necessary to preserve a semblance of anonymity.

The substance of many of the essays consists in reminiscences of Lamb's early years, toward which he looked back with a tender and romantic yearning. He describes, for example, in

the essay entitled "Christ's Hospital Five-and-Thirty Years Ago," his schoolboy life and his first association with Samuel Taylor Coleridge; in "Blakesmoor in H—shire," a visit with his sister, Bridget Elia (Mary Lamb), to an old mansion in the country in his childhood; in "My First Play," his earliest sensations in the theatre; in "Old Benchers of the Inner Temple," the curious personalities of the antique lawyers with whom he had become acquainted in his boyhood home in London. In these essays and others which refer to the circumstances of his own life, Lamb admits us freely to the inner circle of his thought. He frankly confesses his weaknesses and his prejudices. He pictures in "The Superannuated Man" his sensations on finding himself at last free from the business routine of a lifetime; he even writes the "Confessions of a Drunkard," speaking seriously and truthfully of his own experience. Finally, in that most beautiful of all the essays, "Dream Children," he indulges in a vision, regretful but not unmanly, of what might have been had the circumstances of his sad life been different. In all this Lamb is lovable and charming. If a tender melancholy pervades some of the essays, others, like the famous "Dissertation on Roast Pig," are full of hilarious fun. In the majority of his sketches humor and pathos go hand in hand. The sentiment is relieved by brilliant flashes of wit which make Lamb rank as one of the chief of English humorists; the laughter is tempered by kindly sympathy.

Lamb's romantic love of bygone things is apparent everywhere in the essays. He complains of "the decay of beggars in the metropolis," writes "the praise of chimney-sweepers," describing with delightful humor the annual dinner given in their honor by his friend Jem White. He confesses to an almost feminine delight in old china, prefers the sun-dial to the clock and the old type of schoolmaster to the new. In human personality Lamb is most interested in out-of-the-way characters, with some peculiar humor or bias, "odd fishes," like the old-fashioned clerks of the South Sea House or the immortal, whist-playing Sarah Battle. A number of the essays deal with literary matters, particularly with the drama, in which he was much interested, and with those older authors like Sir Thomas Browne, toward whom he was drawn by his antiquarian instinct and by his liking for the unusual and piquant in literature as in life. As a critic Lamb is appreciative and informal, relishing his favorite authors rather than judging them. He is the best and most enthusiastic of all book-lovers.

Whatever his subject Lamb casts upon it the magic of a style rich in personality, picturesque, brilliantly witty and singularly responsive to the author's mood. Quaint turns of phrase and antiquated words, borrowed from the older writers of whom Lamb was fond, give a touch of oddity to his language which suits his highly individual type of humor.

The 'Essays of Elia' are the most attractive example in our literature of the personal or informal essay, compounded of wit and sentiment, observation and reflection, familiar in tone, whimsical and unexpected in idea, but richly human and often touching by way of intimation and suggestion on the deepest truths.

Consult 'The Works of Charles and Mary Lamb' (ed. E. V. Lucas, 1903-05); 'The Essays of Elia' (In 'Everyman's Library'), and 'The World's Classics' (Oxford); essays on Lamb in Walter Pater's 'Appreciations'; A. Birrell's 'Obiter Dicta' (2d series); G. E. Woodberry's 'Makers of Literature,' and C. T. Winchester's 'A Group of English Essayists.' For bibliography, consult 'Cambridge History of English Literature' (Vol. XII).

JAMES H. HANFORD.

**ESSAYS AND REVIEWS**, a work issued in 1860 by seven members of the Church of England, six of whom were laymen. It was severely criticized by the clerical body and in 1864 was condemned by convocation. Two of the seven contributors were sentenced to suspension of one year by the ecclesiastical courts, but the Privy Council reversed this sentence.

**ESSEG.** See **ESZEG**.

**ESSEN**, Hans Henrik, Count, Swedish statesman: b. Kaiås, West Gotland 1755; d. 1824. He received his education at the University of Upsala and entered the army in the service of Gustavus III. In 1795 he was made governor of Stockholm and five years later governor-general of Swedish-Pomerania and Rügen. In 1807 he defended Stralsund against the French and two years later was made a count and a councillor of state. Charles XIII made him Ambassador to France in 1910 and he was successful in having Napoleon restore Pomerania to Sweden. In 1811 he was made field marshal, campaigned in 1813 against Norway, of which he was governor in 1814-16. In 1817 he was transferred and made governor-general of Skåne. Consult the life by Wieselgren (Malmö 1855).

**ESSEN**, Germany, town of Rhenish Prussia, 18 miles northeast of Düsseldorf. It has recently greatly increased in population and manufactories. The cathedral, founded in the 10th century, is one of the oldest in Germany. It is celebrated for the steel and iron works of the Krupps (q.v.) the most extensive in Europe, employing 70,000 workmen in their various undertakings. This great establishment was started in 1811, with only two workmen. The rifled steel cannon made here were supplied to most of the armies of the world. In the suburbs are the "colonies"—cottages, churches, schools, stores, libraries, places of amusement, homes for superannuated and disabled workmen, etc., established by the Krupps for their workmen who, however, on pain of dismissal, are forbidden to become associated with any socialist or trade union organization. During the European War, Essen was frequently attacked and bombed by allied air squadrons. (See **WAR**, **EUROPEAN**). The town was founded in the 9th century, when the Benedictine abbey was established here, and for some time it was under the control of the Abbess of Essen. In the 10th century the Abbess Hagona gave the town municipal privileges. In 1803 it was incorporated into Prussia. The town of Ruttenscheid was annexed to Essen in 1905 and the commune of Huttrop in 1908. Pop. 295,000.

**ESSENCE**, in metaphysics, originally the same as substance. Later, substance came to be used for the undetermined substratum of a

thing, essence for the qualities expressed in the definition of a thing; or, as Locke put it, "Essence may be taken for the being of anything, whereby it is what it is." ('Essay Concerning Human Understanding,' Book III, Chapter III, Section 15). It is now used in a wider sense, to designate the intrinsic nature of a thing. In chemistry, and in popular parlance, essences are solutions of the essential oils in alcohol, and may be prepared by adding rectified spirit to the odoriferous parts of plants, or to the essential oils, and distilling; or simply by adding the essential oil to the rectified spirit, and agitating till a uniform mixture is obtained. The term has, however, received a wider significance, and is applied to any liquid possessing the properties of the substance of which it professes to be the essence. Thus essences of coffee and beef contain in a concentrated form the virtues of coffee and beef, and in some circumstances may be substituted for them.

**ESSENCE DE PETIT GRAIN** (essence of small grain), a perfume produced by the distillation of small oranges while in an unripe state. The oranges for this purpose are taken when about the size of a cherry.

**ESSENES**, ěs-sĕnz', a sect or society of Hyper-Pharisaic Jews, in existence 150 years B.C., and which existed till the 2d century, the remnant then returning to Pharisaic or orthodox Judaism or entering the Christian communion. They are not mentioned in the Bible or rabbinical literature. Josephus the historian (1st century) describes their manner of life in some detail; Philo Judaeus has a notice of it, so too has Pliny in his 'Historia Naturalis.' Josephus was in his youth a probationer of the society, but lived among them only a short time and was unacquainted with the details of their system, which were strictly withheld from novices; but his narrative has the marks of authenticity. In essentials Josephus and Philo are in accord, and with them agrees Pliny in the one peculiarity of this society which he notices—their celibate life. The Essenes were stern ascetics and in that respect were the prototype of the Christian Solitaries, who in the 3d and 4th centuries peopled the Nubian deserts; withal, they were both in name and in deed Friends—for such was one of the appellations of the brethren. Among themselves they had all things in common, like the first Christians, and they were open-handed and hospitable to strangers. They are supposed never to have numbered more than 4,000 souls. There were groups of Essenes in all the towns of Judea, but their institute had opportunity for full development only in their communal settlements on the western shore of the Dead Sea, where they devoted themselves to their peculiar religious observances and to agriculture and a few simple handicrafts. Their food was of the simplest, taken at the common board, their only drink, water; their attire was of the plainest white linen material. None possessed more than one tunic or more than one pair of shoes. They rose at daybreak for prayer; after prayer and a hymn they went about their customary occupations. (Here we are reminded of what Pliny wrote to Hadrian concerning usages of the Christians in Bithynia: "They met on a stated day before daybreak and chanted a hymn

to Christ as God.") At the 5th hour (11 A.M.) they again assembled in one place and bathed their faces in cold water, after which they put on pure white garments and repaired to the common simple meal, which was preceded by a blessing, a prayer and a hymn; and after the repast there was again prayer and a hymn. Then the brethren put off the ceremonial garb of white linen, put on their workday attire, and went back to their employments. No women were admitted to the order; like some of the modern Shakers they adopted young boys and brought them up in their own simple way of living; on attaining maturity they might, if willing, be admitted to membership after a term of probation; or they were free to return to the world. But they also received accessions of life-weary grown people. "Thus," says Pliny, "here is a people that never dies out (*æterna est*) yet in which there are no births: so fruitful for them is others' 'disgust of life'." (*Tam fecunda illis aliorum vitæ pœnitentia est*). They were opposed to trading as leading to covetousness, and to the making weapons of offense, and rejected animal sacrifices. Like the Society of Friends they forbade oaths; and they held that a man whose word needed to be confirmed by oath was not to be believed at all. Nevertheless the postulant for admission into the society was required to take "terrible oaths" that he would pay worship to God, be just to men, injure none, hate the unjust, be faithful and true to all, especially rulers, for none bears rule save by God's will. Pliny writes of a similar oath taken by the Christians.

There were four degrees of membership resembling in some respects the castes of the Hindus. If a person in a higher degree so much as touched one of a lower grade, he was thereby defiled and was bound to make himself clean in cold water. Their severely abstemious life, their contempt for riches and honors, their deep conviction of the immense superiority of their religion gave them all the heroic courage in face of persecution and torture which distinguished the Christians in the ages of martyrdom. So scrupulous were they in avoiding everything like idolatry, that some of them would never enter any city because of the images erected at the gates; nor would they touch a coin that bore the likeness of any ruler.

**Bibliography.**—Pliny, 'Historia Naturalis'; the writings of Josephus and Philo Judaeus; also *Philosophumena*, or 'Refutation of all Heresies,' written in Greek 230 A.D., author unknown; Lightfoot, 'Colossians and Philemon' (3d ed., London 1879); Fairweather, 'The Background of the Gospels' (New York 1908); Pfeiderer, 'Primitive Christianity' (Eng. trans., New York 1912); and Hastings, 'Encyclopedia of Religion and Ethics.'

**ESSENTIAL OILS** are those volatile aromatic constituents of certain flowers, fruits, seeds, etc., which contain their specific odors and flavors—that is, the properties which delight the senses of smell and taste. The object aimed at in the manufacture of these essences is that they may be transferred to other combinations, through which the pleasure they afford may be enjoyed to a far greater extent. The delicacy of the methods to be employed may be better appreciated when it is remembered that these oils are products of the living plants,

and that immediately upon harvesting the plant the essences begin to deteriorate, the loss varying with the period which elapses between the time when the life of the plant is halted and the time when the essential oil is finally secured in a permanent form. Another point to be carefully attended to is that each essence is at its best at a certain time in the growth of the plant, and that it must be taken at that time — neither immature nor past maturity. Other conditions are liable to affect the product injuriously, and heat is one of these. The delicate essence of the strawberry is quickly dissipated if the sun beats down hot upon it, and many other essential oils are as sensitive to heat. And this peculiarity of course prevents the use of the chief refining process of the chemist, that of distillation, for these particular oils. An example of this condition is presented in winning the oil of lemon from the peel. Any attempt to obtain this oil by heat results in a product of low quality. The fine flavor has to be gained by cold pressing of the raspings of the surface. The banana, peach and pineapple are in the same class with the strawberry and the lemon in this respect. This difficulty is overcome in large measure by dissolving out the essential oils with alcohol, and distilling the alcoholic solution under vacuum — which so reduces the degree of heat needed that the delicate flavors are preserved. Another condition likely to injure these sensitive substances is undue exposure of the plants or fruits to the air after harvesting. Some oils quickly become rancid, and in the case of others fermentation of the source of the oil completely destroys it. The class of flavors and odors which are injured by fermentation is practically the same as that which is supersensitive to heat. In the case of some other essences, as of the apple and cherry, fermentation of the fruit serves to accentuate its particular flavor.

Volatile oils consist of two component groups, the taste-carriers and the terpenes. In addition to these there may be varying proportions of waxy and resinous matters. The aim of the manufacturing processes is to eliminate all but the taste-carriers' constituents, for it is solely upon these that its market value depends.

The methods employed in making essential oils are (1) expression; (2) distillation; (3) extraction. The first makes use of simple pressure; the second uses distillation with water or steam, and subsequent rectification to remove the water; the third is carried on by dissolving out the desired oil with a solvent, such as alcohol, chloroform, benzol, etc., these solvents being afterward distilled off at a low temperature under vacuum. The terpenes are removed from some kinds of oil by the vacuum process, being the first to pass over on the rise in temperature. The sesquiterpenes follow. At a slightly higher degree the true flavor carrying oil comes over. When it is necessary to raise the temperature again, the fractions which then distil over are gathered separately, as not of the highest quality. Another method of removing the terpenes used with a class of oils which cannot be worked by the first process, is by alcoholic distillation. In this process one part of the oil to be treated is mixed with five parts of 43 per cent alcohol. Upon heating this mixture vapors containing about 80 per cent alcohol and 20 per cent water, together with the vapors

of the oil, pass over into a receiver where they are condensed. The terpenes separate as they are insoluble in alcohol of that strength. The essential oils remain in solution with the alcohol. The process is continued until the collecting terpenes cease to increase in quantity. The oil thus purified is dried by agitation with anhydrous sodium sulphate, and placed in lightproof and airproof bottles. From these essential oils are made the so-called "essences," tinctures, flavoring extracts, syrups for soda water, perfumes, cordials, liqueurs, etc. Many of the essential oils are used as medicine, or in medicinal preparations, ointments and liniments.

The United States Census of Manufactures for 1914 reported 105 establishments engaged in the manufacture of essential oils, employing 435 persons, of whom 249 were wage-earners receiving annually \$133,272 in wages. The capital invested totaled \$1,616,682, and the year's output was valued at \$2,313,606; of this, \$748,771 was the value added by manufacture. Two other establishments reported making essential oils as a subsidiary product, but the value of their production is not given. See OIL.

**ESSENTUKI, or ESSENTUKSKAYA**, Russia, a health resort in the territory of Terek, northern Caucasus, 10 miles north of Pyatigorsk. It is 2,000 feet above sea-level and is widely known for its cold alkaline springs. Pop. 8,000.

**ESSEQUIBO**, *ës-së-kë'bô*, the largest river of British Guiana, draining about one-half of the area of the colony. It rises in the northern slope of the Akarai Mountains, which marks the watershed between it and the Amazon, takes an irregular northerly course, and flows into the Atlantic west of Georgetown by an estuary 20 miles in width. Its whole length is about 600 miles. It is navigable for some distance from the ocean. The district or division of Essequibo, which is in the basin of the Essequibo River, is well cultivated and extremely fertile, producing coffee, cotton, cocoa and sugar. Its principle tributaries are the Mazaruni, Cuyuni, Potaro, Siparuni and Rupun. A portion of the basin of this river was included in the disputed territory claimed by the Venezuelan and the British governments in 1896. The claims were settled by an arbitration of treaty 2 Feb. 1897, and the award made 3 Oct. 1899. Pop. 36,000.

**ESSEX, Arthur Capel, 1st (CAPEL) EARL OF**, English statesman: b. January 1632; d. 13 July 1683. At the Restoration he was created Viscount Malden and Earl of Essex. He became troublesome to Charles II and to be rid of him the latter sent him as Ambassador to Denmark. His conduct in Denmark restored him to favor and in 1672 he was made privy councillor and lord-lieutenant of Ireland. His subsequent administration lasted five years and was most successful and honest. He kept a just balance between the Catholics, Presbyterians and the members of the Church of England. His opposition to corruption in the administration made him many enemies, who through intrigue brought about his recall. He joined the so-called Country Party under Lord Halifax and again became noted for his opposition to the Crown. With Shaftesbury he supported the Exclusion Bill, designed to keep James from the throne. In 1683 he was arrested and placed in the Tower. His spirits appear to have been

cast down and about a month after his arrest he was found with his throat cut. Consult 'Dictionary of National Biography' and 'Essex Papers' (Camden Society 1890).

**ESSEX, Robert Devereux, 2D EARL OF,** English courtier: b. Netherwood, Herefordshire 19 Nov. 1566; d. London, 25 Feb. 1601. He was educated at Trinity College, Cambridge, and appeared at Court in 1577. He greatly distinguished himself at the siege of Zutphen in 1786. On Leicester's death 1588, he became the chief favorite of Elizabeth. In 1590 he married the widow of Sir Philip Sidney, and in 1591 was sent to support Henry IV against Spain, but the expedition effected nothing of importance. About this time Essex was on terms of close friendship with Francis Bacon, who assisted him greatly by advice on political and other matters. In 1596 he commanded an expedition to Spain, and greatly distinguished himself at the capture of Cadiz. In 1597, after an unsuccessful expedition to the Azores, he, with Howard and Raleigh, made extensive captures of Spanish ships. He became earl marshal and chancellor of the University of Cambridge. Next year he quarreled with the queen, who struck him on the ear and bade him "go and be hanged." After some months a reconciliation took place, and he was appointed lord-lieutenant of Ireland (1599), then in a state of rebellion. He returned to England in September, having been entirely unsuccessful in his government and made a humiliating truce with the rebels; was made a prisoner in his own house, and was shortly afterward (June 1600) tried by special court. The charges against him were that he had exceeded his instructions in the Irish campaign, and had deserted his post without leave; and he was deprived of all his offices, and sentenced to imprisonment, but not long afterward was set at liberty. He now conceived a deep resentment against the queen's councillors particularly Cecil and Raleigh, who, he imagined, had biased her against him. Being summoned before the council, he assembled his friends in his house, and proceeding to the city, endeavored to enlist the citizens to enforce dismissal of the queen's ministers. After a skirmish with a party of soldiers he returned to his house, but after a short defense was compelled to surrender, and sent to the Tower. He was tried for treason on 19 February and executed on 26 Feb. 1601. Consult Croxall, 'Memoirs of the Unhappy Favorite' (1729); Spedding, 'Bacon' (1881); Abbott, 'Bacon and Essex' (1877).

**ESSEX, Robert Devereux, 3D EARL OF,** English soldier: b. 1591; d. 14 Sept. 1646. When 11 years old he was restored by James I to the rank and titles held by his father, the 2d earl. He served in the army of the elector palatine in Holland 1620-23, was vice-admiral of an unsuccessful naval expedition against Cadiz in 1625, and lieutenant-general of an army sent by King Charles against the Scotch Covenanters in 1639. He, however, was opposed to the arbitrary measures of the king, refused payment of the forced loan in 1626, supported the Petition of Right, and in spite of attempts to detach him, favored the execution of Strafford. Espousing the cause of the Parliament against the king, he was appointed to the command of the parliamentary army at the beginning of the civil war, was victorious over Charles at Edgehill

in 1642, captured Reading in 1643, and relieved Gloucester, but his invasion of Cornwall in the following year was a failure; the greater part of his army surrendered at Lostwithiel, and he was obliged to escape by sea. He dissented from Cromwell's measures against the Scots as likely to stir up ill will between the two nations, and resigned in anticipation of the Self-Denying Ordinance in 1645.

**ESSEX, Thomas Cromwell, Earl of.** See CROMWELL, THOMAS.

**ESSEX, Walter Devereux, 1ST (DEVEREUX) EARL OF,** English soldier: b. 1541; d. 1576. He served as high marshal under Warwick and Clinton in 1569 and rendered valiant service in putting down the rebellion in the north. In 1572 he was created Earl of Essex as a reward for his zeal in the queen's service. In 1573 he offered to subdue and colonize a portion of the province of Ulster. His offer was accepted with some modifications and he set out in July 1573 with a force of about 1,200 men. Storms delayed the expedition and sickness, death and desertions cut the force to about 200 men. Meanwhile Essex was in difficulty with the lord deputy, Fitzwilliam, his operations consisted of raids and brutal assaults on the O'Neills. By treachery he captured Sir Brian MacPhelim, leader of the O'Neills, slaughtered his attendants, and executed him, his wife and brother at Dublin. He next prepared to attack the Irish chief, Tirlough Luineach, defeated him and massacred several hundreds of the followers of Sorley Boy McDonnell, mostly women and children whom he found hiding on Rathlin Island. In 1575 he was recalled, retired from public life, but returned to Ireland the year following as earl marshal. He died in Dublin soon after his arrival.

**ESSEX, Canada,** a town in the province of Ontario, on the Michigan Central Railroad, 15 miles southeast of Windsor. Electric tramways connect it with Leamington, Kingsville and Windsor. It contains flour and planing mills, brick and tile yards and a large canning establishment. Natural gas is plentiful in the district. Pop. 1,353.

**ESSEX, Conn.,** a town in Middlesex County, on the New York, New Haven and Hartford Railroad, and on the Connecticut River, 30 miles southeast of Hartford. It contains a large piano factory, a tool factory and a public library. Pop. 2,745.

**ESSEX, England,** a maritime county, on the southeastern coast; area, 1,530 square miles, of which 80 per cent is under cultivation. In the northwest wheat and barley are the principal crops; fringing the coast were formerly swamps, now turned with excellent grazing land; there are no great manufactures, but the fisheries are important. The Stour, Colne, Blackwater, Lea and Thames are the principal rivers. The chief towns are Chelmsford, the county town, Colchester, Maldon and Harwich. Essex is one of the six "Home Counties," and took its name from the East Saxons, whose monarchs reigned over it from A.D. 617 to 823, when the kingdom was absorbed by the West Saxons. It was recognized as Danish territory by Alfred the Great at the Peace of Wedmore in 879, but was reconquered by his son, Edmund the Elder. In 1045 it was a part of the earldom of Harold, but passed into the



hands of the Norman conquerors. The county was rich in monastic foundations, of which few traces remain; and has some noteworthy ancient churches and other ecclesiastical antiquities. The county for parliamentary purposes is divided into eight divisions, each returning one member. Pop. 1,350,881.

**ESSEX**, Vt., town in Chittenden County, on the Central Vermont Railroad, 10 miles northeast of Burlington. It is the seat of the Essex Classical Institute. Agriculture and dairying are the only industries. Pop. 2,714.

**ESSEX AND ALERT**, Naval Action Between the, in the War of 1812. On 3 July 1812 the American frigate *Essex*, rated as a 32 but carrying 44 guns, under Capt. David Porter (q.v.) and with David G. Farragut (q.v.) as a midshipman, left New York and after capturing a brig containing 197 soldiers on 10 July, came up with (30 August) and was chased by the British sloop of war *Alert* (rated at 16 guns, but carrying 2 long 12's and 18 short 32's), under Capt. Thomas L. P. Langhorne. Deceived as to the nature of the *Essex*, the *Alert* closed up and opened fire, whereupon the *Essex* nearly sank her with a broadside and after five minutes of fighting compelled her to strike her colors. The *Alert* was then converted into a cartel and Porter's prisoners were sent in her on parole to Saint John's, Newfoundland. After taking a few more prizes and being chased by two British ships, Porter returned to port 7 September. Consult Cooper, J. F., 'Naval History' (Vol. II, pp. 52-55); Farragut, Loyall, 'Life of Farragut' (pp. 15-17); James, William, 'Naval Actions' (pp. 5-6); Maclay, E. S., 'History of the Navy' (Vol. I, pp. 326-31); Roosevelt, 'Naval War of 1812' (pp. 52-82); Spears, John R., 'Life of Farragut' (pp. 47-51), and 'History of Our Navy' (pp. 33-50).

**ESSEX HOG.** See HOGS.

**ESSEX JUNCTION**, Vt., village in Chittenden County, seven miles east of Burlington, on the Central Vermont Railroad. It contains Fort Ethan Allen and a national army post. It has also grain and lumber mills, brickyards, a corn-canning factory and a butter factory. Its agricultural interests are extensive. The village owns its water plant. Pop. 1,245.

**ESSEX JUNTO**, a name applied about 1778 by John Hancock to the group of Massachusetts political leaders resident in or connected with Essex County, Mass.—the northeastern county, from just north of Boston to the New Hampshire boundary. Its coast was a line of commercial and fishing towns and its interests therefore overwhelmingly in favor of a strong national government to protect them from foreign countries and their sister states. This made its leaders, whose great ability gave them powerful influence, the vanguard of the ultra Federalists and adherents of Hamilton, whom they followed in his split with John Adams. The latter revived the old nickname, charged them with being a "British faction" and forcing on a war with France and for years after his retirement assailed them in the press. When the embargo (q.v.) and the later war solidified all New England Federalism in a common self-defense, all the opposition and the suspected treason were attributed by out-

siders to the Essex Junto. Its chief members were George Cabot, Timothy Pickering, Theophilus Parsons (State chief justice), the Lowell family, Stephen Higginson and Benjamin Goodhue. The "Junto" disappeared with the War of 1812 as far as its influence on national affairs was concerned. It held on for a few more years in some New England States, but by 1823 its candidates were defeated even in Essex County. Consult Brown, C. R., 'The Northern Confederacy according to the Plans of the Essex-Junto' (Princeton 1915).

**ESSEX, PHOEBE AND CHERUB**, Battle of the, in the War of 1812. On 28 Oct. 1812, the *Essex*, under Capt. David Porter (q.v.), passed the Delaware Capes and ran south to meet the *Constitution*, but failing in this continued her voyage and on 12 December, a little south of the equator, captured the British frigate *Norton*, which was dispatched to the nearest American port but which on the way was recaptured by the *Belvidere*. Porter then sailed around Cape Horn, arrived at Valparaiso, Chile, 14 March 1813, supplied his ship and in the next few months cleared the seas of British whalers and warships, one of which he turned into a 20-gun ship and renamed the *Essex Junior*. After numerous adventures the two ships put in at Valparaiso, where on 8 Feb. 1814, they were found and blockaded by the British frigates *Phæbe* (13 long 18's, 1 long 12, 1 long 9, 7 short 32's and 1 short 18), Capt. James Hillyar, and *Cherub* (2 long 9's, 2 short 18's and 9 short 32's). The *Essex* was armed with 17 short 32's and 6 long 12's so that while she could overpower the *Phæbe* at short range, the latter's long range 18 pounders would enable her completely to destroy the *Essex* from a position beyond reach of the latter's guns. For a month Porter lay practically idle, but, on learning of the approach of several other ships, had decided to run the blockade when on 28 March 1814, the *Essex* parted her port cable; he thereupon attempted to escape but a mishap compelled him to return. As he was anchored in a small bay a short distance from shore, Porter supposed the British would respect the neutrality of the port and had begun to make repairs when the *Phæbe* and *Cherub* bore down on him and a few minutes before 4 o'clock opened fire. As the *Phæbe* was on her stern and the *Cherub* off her starboard bow, the *Essex* could not reply effectively with her broadside, but Porter ran two long 12's out of the stern ports and at 4.30 compelled the *Phæbe* to haul off to repair damages. Since Porter's long guns could not be brought to bear and his carronades could not reach them, the British ships then proceeded leisurely to pound the *Essex* to pieces, the *Phæbe* anchoring and firing her broadsides of long 18's into the quarter of the *Essex* while the *Cherub* kept under way and threw solid shot from her bow guns. Porter then attempted to run his vessel ashore but was prevented by a shift of the wind; accordingly he let an anchor go, brought the head of his vessel around and gave the *Phæbe* a broadside that crippled her and caused her to drift away with the tide. Unfortunately at this moment the hawser of the *Essex* parted and, a helpless wreck, she aimlessly floated toward her antagonist; twice she took fire, part of her powder exploded, she had been hulled

at almost every shot, and at 6.10 her colors were hauled down, though the British did not cease firing until 6.20. The *Essex* lost 58 killed and 66 wounded and 28 drowned or missing out of her crew of 255, while the British loss was only five killed and 10 wounded. The *Essex Junior* was converted into a cartel and Porter and the survivors were sent to New York, arriving in July 1814. Consult Adams, 'United States' (Vol. VIII, pp. 174-181); Barnes, James, 'Naval Actions of the War of 1812' (pp. 171-87); Cooper, J. F., 'Naval History' (Vol. II, pp. 76-97); James, William, 'Naval Actions' (pp. 78-82); Maclay, E. S., 'History of the Navy' (Vol. I, pp. 543-75); Mahan, A. T., 'War of 1812' (Vol. II, pp. 244-52); Porter, 'Journal of a Cruise made to the Pacific Ocean by Capt. David Porter in the United States Frigate *Essex*' (2 vols., 1815); Porter, David D., 'Life of Porter'; Roosevelt, 'Naval War of 1812' (pp. 293-309); Spears, J. R., 'History of Our Navy' (Vol. III, pp. 1-53); Wiley and Rines, 'The United States' (Vol. V, pp. 486-93); and biographies of D. G. Farragut, by Loyall Farragut, J. R. Spears, A. T. Mahan, James Barnes and P. C. Headley.

**ESSEX SKULL.** See **MAN**, PREHISTORIC TYPES OF.

**ESSIPOFF, Annette**, Russian pianist: b. Saint Petersburg 1851. She studied under Leschetitzky, of whom she was the most brilliant pupil. In 1874 she began her career in Saint Petersburg, made successful tours in Europe, and in 1876 visited the United States, where she also achieved a large measure of success. She married Leschetitzky in 1880, but the pair soon separated and were divorced. She taught piano at the Saint Petersburg Conservatory from 1893 to 1908.

**ESSLINGEN**, or **ESSLING**, Austria, a village about six miles east of Vienna, famous as the scene of a battle between the French and Austrians on 21-22 May 1809. It is sometimes known as the battle of Aspern.

**ESSLINGEN**, ɛs'ling-ən, Germany, town in Württemberg, on the Neckar, seven miles east-southeast of Stuttgart. It was founded in the 8th century and was long a fortified, Imperial free town. There are three noteworthy churches of the 12th, 13th and 15th centuries respectively. Originally Esslingen belonged to the duchy of Swabia and the Swabian League of Swabian cities and governments was formed here in 1488. There are great railway workshops, manufactories of machinery, cutlery, cotton, dye-works, paper and beer. Pop. 32,364.

**ESSON, William**, British mathematician: b. 1838. He received his education at the Inverness Royal Academy and at Oxford. In 1860-97 he was Fellow of Merton College and also of New College. In 1894-97 he served as deputy Savilian professor and after the latter year was full professor at Oxford. He was elected member of the Royal Society, in whose 'Transactions' appeared his 'Laws of Connection between the Conditions of Chemical Change and its Amounts' (1864, 1866, 1895) and 'Variations with Temperature of Rate of Chemical Change' (1912).

**ESSONITE**, or **HESSONITE**, a variety of garnet (q.v.), also often called Cinnamonstone (q.v.).

**ESSONNES**, es'son, France, town in the department of Seine-et-Oise, 20 miles southeast of Paris. Its industries comprise iron foundries, linen and paper manufactories and machinery. Pop. (commune) 9,348.

**ESTABLISHMENTS**, Ecclesiastical, religious bodies having prescribed relations to the state in return for which they enjoy various privileges and are obligated to certain duties. The origin of the custom harks back to the period when the religious belief of a nation was unanimous and there existed much less of a mixture of faiths such as we witness to-day among practically all modern nations. In England, the connection between Church and State grew up prior to any formal legislation on the subject, and at the Reformation, as in other countries which then changed their spiritual affiliation, passed to the new denominations. In Ireland the Protestant Church, though in a minority, enjoyed all the privileges of an established church until 1870. The usual connection between an established religion and the state is seen in the appointment of higher church officials by the secular power, by taxation for the support of the clergy, by regulation of religious property, by the maintenance of ecclesiastical courts in which the canon law is enforced, and by the founding of a system of education under the general supervision of the clergy. England, Greece, Sweden, Norway, Prussia and other German states, and until 1917 Russia, have established churches. In certain republics of Latin America the Catholic Church enjoys special privileges, but the nearest approach to an established church in America is to be found in the Province of Quebec. For the particular relations existing between the church and these states see articles on the various countries.

**ESTAING**, ɛs-tān, **Jean Baptiste Charles Hector, COMTE D'**, Marquis of Saillans, French army and navy officer: b. Auvergne, 1729; d. Paris, 28 April 1794. He entered the French army as colonel of infantry; was promoted to brigadier-general in 1757, and in 1777 became vice-admiral in the French navy. In 1778, in accordance with the treaty between France and the United States, France fitted out a fleet of 12 ships of the line and four frigates to aid the latter in the struggle against Great Britain and Estaing was placed in command. He sailed 13 April, reached Delaware Bay in July, and proceeded to New York. He captured some prizes off the coast of New Jersey, agreed to assist in a land and sea attack on Newport to expel the British from Rhode Island; reached the harbor late in July; and hearing of the approach of a fleet, put to sea to meet it. He was overtaken by a severe storm, which caused him to put into Boston for repairs and the projected attack failed. Subsequently he captured Saint Vincent and Grenada, West Indies, and in 1779 co-operated with General Lincoln in an ineffectual attempt to capture Savannah, Ga. He returned to France in 1780. He commanded the allied fleets of France and Spain in 1783; was chosen admiral of the navy in 1792. He was in favor of the French Revolution, and was one of the Assembly of Notables. In 1789 he was commander of the National Guard, and three years later admiral by the selection of the Legislative Assembly. Two years later, prob-

ably, because he had tried to save the life of Marie Antoinette, despite his eminent military and naval services to France he was condemned as a royalist and guillotined. Estaing had ambition to shine as a literary man and he wrote poetry, a drama and a work on the Colonies.

**ESTAMPES**, or **ETAMPES**, Anne de Pisseleu, Duchesse n', French adventuress, mistress of Francis I: b. 1508; d. 1585. She was maid of honor to Louise of Savoy, the mother of Francis, who fell under her charms in 1526 soon after his return from Spain. At the age of 28 she was married formally to Jean de Brosse and received the title of Duchesse d'Estampes. She wielded a powerful influence over Francis, but there soon arose a rival in the person of Diane de Poitiers, the mistress of the Dauphin. Political parties gathered about these two courtesans but the accession of Henry in 1547 totally eclipsed the Duchesse d'Estampes who retired to her estates. She embraced Protestantism and was a staunch supporter of the Huguenot cause. Consult Paris, Paulin, 'Etudes sur François Ier' (Paris 1885).

**ESTANCIA**, ěs-tanthĕ-ă, Philippines, a pueblo of the province of Iloilo, situated on the eastern coast of the island of Panay, 66 miles north of the town of Iloilo. The main portion of Estancia is one mile inland, connected by a good road with the coast and anchorage ground. Pop. 12,700.

**ESTATE**, a term sometimes used to indicate property generally, whether personal or real. Sometimes it includes land alone. It signifies in law the interest which a person may have in property. It denotes the time during which ownership may exist, as for a year, for life or forever. At common law estates in land are divided, as regards the quantity of interest, into two kinds, (1) freehold estates, and (2) estates less than freehold. A freehold is an estate which may last for life or longer. An estate which is circumscribed within a certain number of years, or one in which the possessor has no fixed right of enjoyment, is less than freehold, and although in fact it may last longer than the life of its first possessor, still the law regards it as a lower estate than a freehold; it is personal property in the eye of the law, and does not descend to heirs, although it may pass to executors or administrators.

Freehold estates are divided into estates of inheritance, which pass to heirs, and estates not of inheritance; the former are again divided into estates in fee simple and estates in fee tail. An estate in fee simple is the estate which a man has where lands are given to him and his heirs absolutely without any end or limit put to his estate, and it is the most extensive and the highest interest a man can have in land. If not aliened or devised, it passes to heirs generally. On the other hand, a fee tail is an estate which is limited to certain particular heirs or to a certain class of heirs, to the exclusion of the others; as to the heirs of one's body, which excludes collateral heirs, or to the heirs male of one's body, which excludes females.

In the United States fee tails have had only a limited existence, and are now in general abolished. They were changed into estates in fee simple in New York as early as 1782. Freeholds not of inheritance are for life only, either

for the life of the tenant or of some other person or persons; when the estate is called an estate *pour autre vie*. Life estates are created by operation of law, or by the act of the parties. An example of an estate created by act of the parties is where A conveys land to B for the term of his natural life, or where A conveys land to B without mentioning the duration of the term. Here under the common law B would take only a life estate; but by statute in many of the States—among them New York—a grant or devise of real estate possesses all of the interest of the grantor or testator, unless the intent to pass a less estate or interest appears by express terms or by necessary implication.

Dower and curtesy are estates created by operation of law. An estate by the curtesy is that estate to which a husband is entitled upon the death of his wife in the lands or tenements of which she was seized in possession in fee simple or fee tail, during their coverture, provided they have had lawful issue born alive, and possibly capable of inheriting her estate. An estate in dower is an estate which a widow has for her life in some portion of the lands of which her husband was seized at any time during coverture, and which her issue might have inherited if she had any, and which is to take effect in possession from the death of her husband.

Estates less than freehold are divided into estates for years, at will and by sufferance. An estate for years is an interest in lands by virtue of a contract for the possession of them for a definite and limited period of time. Such estates are ordinarily called terms. The length of time for which the estate is to endure is of no importance in ascertaining its character, unless otherwise declared by statute. An estate at will is where one man lets land to another to hold at his will, as well as that of the lessee. An estate of this kind is terminated by either party on notice. Out of estates at will a class of estates has grown up called estates from year to year, which can be terminated only by six months' notice, expiring at the end of the year. An important element in creating this estate is the payment of rent. An estate at sufferance is the interest of a tenant who has come rightfully into possession of lands by permission of the owner, and continues to occupy the same after the period for which he is entitled to hold by such permission. This estate is not of frequent occurrence, but is recognized as so far an estate that the landlord must enter before he can bring ejectment against the tenant. If the tenant has personally left the house, the landlord may break in the doors, and the modern rules seem to be that the landlord may use force to regain possession, subject only to indictment if any injury is committed against the public peace.

Estates may depend upon condition; that is, their existence may depend on the happening or not happening of some event whereby the estate may be created, enlarged or defeated. A term for years, a freehold or a fee may thus be upon condition. The condition must either be precedent, that is, must happen before the estate can vest or be enlarged; or must be subsequent, when it will defeat an estate already vested.

Estates may also be divided into estates which are legal and those which are equitable. Estates are termed equitable when the formal ownership is in one person, while the beneficial ownership is in another. In another form of expression it

may be said that a trust is created. The nature of the estate is not affected by this distinction. For example, a trust estate may be an estate for life or a fee, and in the latter case is transmissible to heirs as though it were a legal estate.

Estates are divided into estates in possession and estates in expectancy, in regard to the time of enjoyment. An estate in possession is one in which there is a present right of enjoyment. Estates in expectancy are those which give either a vested or contingent right of future enjoyment. Estates are also divided, in regard to the number of owners, into estates in severalty, in joint tenancy, in common and in coparcenary. An estate in severalty is one which has only a single owner. An estate in joint tenancy is an estate owned jointly by two or more persons, whose title is created by the same instrument. The right of survivorship is the distinguishing characteristic. When a tenant dies his interest is extinguished, and the estate goes to the survivors. Where an estate is conveyed to two or more persons, at common law, without indicating how it is to be held, it is construed to be in joint tenancy. In most of the United States, however, this rule has been changed by statute, and persons to whom an estate is conveyed or given take as tenants in common, unless they hold as trustees. An estate in common is an estate held in joint possession by two or more owners at the same time by several and distinct titles. An estate in coparcenary is an estate which several persons hold as one heir, whether male or female. This estate has the three unities of time, title and possession. The interests, however, of the coparceners may be unequal. In the United States this estate is essentially extinguished, and heirs take as tenants in common.

**ESTATE DUTIES.** See **DEATH DUTIES.**

**ESTE**, *ēs-tā*, the name of an illustrious and ancient Italian family. **ALBERT AZZO II** is considered the founder of the greatness of his house. He inherited or acquired Este, Rovigo, Montagnana, Casal Maggiore and other places in Italy; and was made governor of Milan by Henry III in 1045. One of his sons became Duke of Bavaria in 1071, by the title of Welf I. He was the ancestor of the German branch of the house of Este, the dukes of Brunswick and Hanover from whom the royal house of Great Britain, also called Este-Guelphs, trace their descent. **ALBERT AZZO** died 1097, having previously resigned his Italian possessions to his son **FULK**, and retired to Burgundy. **FULK I** was attacked by his brother **Welf**, who compelled him to become tributary to him to the extent of a third of his revenues. He was succeeded (1137) by his son **OBIZZO I**, who joined the Lombard league against Frederick Barbarossa in 1167. He d. 1193, and was succeeded by his son, who in the annals of the family is called **Azzo V**. Either he or **Oberto** acquired by marriage Ferrara, with its dependencies in Romagna, and with a feud which became hereditary with the house of **Torello**, for a member of which house the bride, violently carried away by the **Estes**, was intended. The house of Este thus became vassals of the Church as well as of the Empire. He was succeeded by **Azzo VI** (d. 1212). He was constantly engaged in war with the **Torelli**, by whom he was thrice driven from

Ferrara. **ALDOBRANDINO**, his son, died young, and was succeeded by his brother **Azzo VII**, a minor, in 1215. He was engaged in protracted wars with the Ghibelline party. **Honorius VII** invested him with the marquisate of Ancona. He d. 1264, and was succeeded by his grandson, **OBIZZO II**, who was chosen lord of Modena and Reggio. We may pass over his successors to **Niccolo III**, who succeeded in 1393 at the age of nine. During his reign, and those of some of his predecessors, the house of Este became patrons of literature. **Niccolo** died at Milan 26 Dec. 1441. **LIONEL**, his son (1441-50), receives a high character from **Muratori** for justice and piety, and for his patronage of letters. He mediated a peace in 1450 between the Venetians and **Alfonso**, king of Sicily, and died in November of the same year. He was succeeded by his brother, **BORSO** (d. 20 Aug. 1471), who received new accessions of dignity from the emperor, and was created Duke of Ferrara by **Pope Paul II**. His reign was peaceable and prosperous. **ERCOLE I**, his brother (d. 25 Jan. 1505), succeeded, to the prejudice of his son **Niccolo**. His usurpation caused a war, which was unsuccessful in deposing him. He had Milan and Florence for allies, the Pope and Venice for adversaries. After the conclusion of peace in 1484 he maintained neutrality in his estates for the remainder of his reign, while the rest of Italy was convulsed with wars and revolutions. He had for his minister **Boiardo**, the famous author of the 'Orlando Innamorato'; and **Ariosto**, born near the commencement of his reign, grew up under his patronage. **ALRONSO I**, his son, d. 31 Oct. 1534. His reign was a contrast to the peaceable one of his father. In 1509 he joined the League of Cambrai, and commanded the Papal army as gonfalonier. While conducting the operations of the allies elsewhere, his estates were ravaged by the mercenary troops of Venice, whose atrocities are described in the 36th canto of the 'Orlando Furioso.' **Alfonso** continued in the French alliance after the Pope had joined the Venetians. He assisted in the battle of Ravenna, and took prisoner **Fabrizio Colonna**, the general of the Pope. After the French had been driven from Italy he endeavored to make peace with the Pope; but **Julius** continued implacable. **Leo X** restored him to his possessions, with the exception of Modena and Reggio, but afterward excommunicated him. He joined in the wars between **Francis I** and **Charles V** on the side of the French king, but was afterward reconciled with the emperor, who confirmed him in his possessions, against **Pope Clement VII** (1530). He married as his second wife the famous **Lucrezia Borgia** (q.v.). His brother, the Cardinal **Ippolito**, was the patron of **Ariosto**. **Alfonso** was succeeded by his son, **ERCOLE II**, who died 3 Oct. 1559. He married **Renée** of France (daughter of **Louis XII**) in 1528. She favored the Reformation, and made the court of Ferrara the resort of the few advocates of that cause in Italy. **Calvin** visited it in 1535. **Ercole** at first adhered to the imperial party, but in 1556 joined the league of **Paul IV** and **Henry II** of France against Spain, and was made general of the allied forces; but did not push the war with vigor, and made peace with Spain in 1558. **Leonora**, his daughter by **Renée**, was the object of the unfortunate attachment of **Tasso**. He was succeeded by his son, **ALPONSO**

II, the patron and persecutor of Tasso, who died 27 Oct. 1597. He was succeeded by his cousin CESARE (d. 11 Dec. 1628), whom by his testament he had made his heir; but this disposition was annulled by the Pope, Clement VIII, who excommunicated Cesare and deprived him of Ferrara, with the dependencies of the Church. Cesare was obliged to content himself with Modena and Reggio, which depended on the empire. From this period the political importance of the house of Este greatly diminishes. ALFONSO IV, who lived in the latter half of the 17th century, was distinguished for his patronage of the fine arts. His daughter, Mary of Modena, was married to James II of England. RINALDO (1655–1737) by his marriage with the daughter of the Duke of Brunswick-Lüneburg, reunited the German and Italian branches of the house. By the death of his grandson in 1803 the male line became extinct. His only daughter was married to the Archduke Ferdinand of Austria, third son of Francis I, who founded the Austrian branch of the family which existed until 1875. The last sovereign of the house was FRANCESCO V, who succeeded in 1846. In 1859, the dynasty was deposed by the National Assembly, the duchy was annexed to Sardinia by the Treaty of Zürich, 10 Nov. 1859, and has consequently been incorporated with the kingdom of Italy. Consult Browning, 'Guelfs and Ghibellines' (1893); Gardner, 'Princes and Poets of Ferrara' (1904); Noyes, 'The Story of Ferrara' (1904); Sismondi, 'Italian Republics' (Eng. trans., 1832); Symonds, 'The Renaissance in Italy' (1875–76).

**ESTE**, Italy, town in the province of Padua, 17 miles southwest of Padua; the ancient Adeste. Its chief industries centre in pottery, cordage and ironware products. The leaning tower, or campanile, is an interesting feature of the town, as is the battlemented mediæval fortress, known as the Rocca. Here once ruled the Este family, one of the most ancient and illustrious families of Italy. In the 11th century the house of Este became connected by marriage with the German Welfs, or Guelphs, and founded the German branch of the house of Este, the dukes of Brunswick and Hanover. The reigning house in Great Britain descends from this family. The sovereigns of Ferrara and Modena were also of this family, several of them being famous as patrons of letters. The lives of Boiardo, the author of 'Orlando Innamorato,' Ariosto and Tasso were closely connected with members of this house. The last male representative of the Estes died in 1798. His daughter married a son of the Emperor Francis I of Austria, who founded the Austrian branch of the house of Este, of which the male line became extinct in 1875, his title then passing to the Archduke Francis Ferdinand, heir to the Austrian throne. Pop. 11,700.

**ESTEBANEZ**, Calderon, Don Serafin, Spanish author, best known as "El Solitario": b. Malaga, 27 Sept. 1799; d. Madrid, 5 Feb. 1867. He studied for the legal profession at the University of Granada, was called to the bar and settled for some time in Madrid. In 1822 he was appointed professor of poetry and rhetoric at the University of Granada, and in 1831 under his pseudonym of "El Solitario" he published a volume of verses. He wrote several

articles on Andalusian customs \*for *Cartas Españoles*, and in 1834 became auditor-general of the Legitimist army of the north. Two years later he was made mayor (*Jefe-político*) of Logróno, but before entering on his new duties an accident obliged him to retire to Madrid where he set about collecting manuscripts of the national literature of Spain. In 1838 he was made jefe-político of Seville and thereafter served several terms as deputy. In 1856 he was elected to the Council of State. In 1847 appeared his greatest original work, 'Escenas andaluzas,' inimitable as records of a life most of which has now gone. His manuscript collections are now the property of the Spanish government. Consult Canovas del Castillo, 'El solitario y su tiempo' (2 vols., Madrid 1883).

**ESTELLA**, Spain, town in the province of Navarre, 20 miles southwest of Pamplona. It is a well-built city with fine streets and many interesting churches, some of which are many centuries old. Its trade and manufactures are also considerable and it is a place of military importance. The town was taken by the Carlists in 1835, and in 1839 was executed here the Carlist leader, Maroto, with five other generals of that party. Again in the seventies it was the scene of spirited conflicts and the stronghold of Don Carlos. When the latter lost the town in 1876 his cause suffered a complete collapse. Pop. 5,638.

**ESTEPA**, Spain, town in the province of Seville, 60 miles east of the city of that name, and situated in a hilly region. It contains a famous old Moorish castle and has fine broad streets. Agriculture and stockraising are its principal interests but it has also manufactures of oil soap. Jasper quarries in the neighborhood give employment to a large number of persons. Estepa is the ancient Astapa, which came into prominence during the Second Punic War for the heroic resistance of its citizens who chose to die by fire rather than surrender to the Roman besiegers. Later it was a flourishing Roman colony. Ferdinand III took it from the Moors in 1240. Pop. 8,234.

**ESTEPONA**, Spain, seaport in the province of Malaga, on the Mediterranean coast, 25 miles northeast of Gibraltar. It is situated in a fertile region which produces fruits, grain, vegetables and wine. Its coast trade is hampered by the lack of adequate harbor facilities but its fishing interests are considerable and it has distilleries, leather-curing establishments, rope and cork works and brick and tile yards. Pop. 9,613.

**ESTERHAZY**. See ESZTERHAZY.

**ESTERIFICATION**. See ESTERS.

**ESTERS** (an arbitrary modification of ether). Compound ethers, or ethereal salts, are compounds in which one or more alcohol or basic radicals are united to one or more acid radicals. They are analogous to the salts of the metals. Thus  $\text{CH}_3\text{COO.H}$  is acetic acid and if the typical hydrogen of this acid is replaced by the monad radical ethyl, the resulting compound,  $\text{CH}_3\text{COO.C}_2\text{H}_5$ , is known as ethylacetic ester. Chemically, this substance is analogous to potassium acetate,  $\text{CH}_3\text{COO.K}$ , obtained by replacing the hydrogen of the acetic acid by potassium. The word

ester was originally applied by Gmelin to compounds of the alcoholic radicals with oxygenated acids; but it has now been extended so as to include all the salts of the alcoholic radicals. Ethyl bromide,  $C_2H_5Br$ , for example, is now included among the esters. Some of the esters are prepared by the direct action of the acid upon the alcohol. In other cases a mixture of the acid and the alcohol is distilled with the addition of sulphuric acid, zinc, chloride or other dehydrating agent. The esters may also be prepared by treating the iodide of the alcohol radical with the silver salt of the acid, the iodine and silver combining to form iodide of silver, while the liberated alcoholic and acid radicals combine to produce the desired ester. The esters of the organic acids occur in fruits and flowers and are also prepared artificially for flavoring purposes and for improving the bouquet of wines. The fats and oils which contain glycerine in combination with oleic, margaric and other acids may be regarded as esters, since glycerine is a triatomic alcohol. Much attention has been paid to the esters in connection with theoretical chemistry, since they are well adapted for the study of the laws of mass-action. See EQUILIBRIUM, CHEMICAL; ETHER.

**ESTES**, Dana, American publisher: b. Gorham, Me., 1840; d. 1909. He received his education in the public schools, for many years was engaged in mercantile affairs and served in the Union army in the Civil War. He became a member of the publishing firm of Degen, Estes and Company, and afterward that of Lee and Shepard. In 1872 he became a partner in the firm of Estes and Lauriat, which in 1898 became known as Dana Estes and Company. He was also a traveler of note, being the first American to explore the region of the Nile as far as Uganda and the Kongo. He also helped organize the International Copyright Association, of which he became the first secretary. He wrote 'Chimes for Childhood' (1868); 'Spectrum Analysis Examined' (1872); and was the editor of 'Half-Hour Recreations in Popular Science' (2d ed., 1879).

**ESTEVAN**, Canada, town in Assiniboia District, on the Canadian Pacific Railway and on the Souris River, 145 miles southeast of Moosejaw. Flour mills, lumber and brick yards, grain elevators are its principal industries. It has also a government coal-testing plant and there is a large trade in coal and brick. The electric-light plant is the property of the town. Pop. 4,000.

**ESTHER**, or **HADASSAH** (Heb. myrtle; Babylonian, Ishtar), the name of a Jewish maiden, chosen by Xerxes to be his queen. She was one of the heroines of Hebrew history and maintained the rights of her nation at the court of the king of Persia. Esther gave her name to the 'Book of Esther,' one of the books of the Bible. According to the account given in the latter, Esther belonged to the tribe of Benjamin. Much controversy has been expended over the character of Esther whom the more radical Biblical critics have been inclined to look upon as a purely mythical personage evolved from the Jewish knowledge of the Babylonian goddess, Ishtar, a name which, in later Babylonian, becomes Estrā. The Jewish account of the life of Esther states that she was the daughter of

Abihail who died while she was quite young, leaving her to the care of her cousin Mordchai in Susa, then the capital of Persia. When she had grown to be a young woman, Xerxes (Ahasuerus) divorced his queen, Vashti, and made Esther queen in her place. But according to Herodotus Xerxes had only one queen, Amestris, whose character and history in no manner resemble those of Esther. Moreover, it has been pointed out by critics that the Persian sovereigns were bound by a certain court etiquette, and by Persian custom, to select their legal wives from the Persian royal family or from the daughters of foreign royal families in order to maintain the purity of the blood of the Persian sovereign. This was looked upon as of great importance in an age when the royal family was believed to be the direct blood descendants of the gods. Vashti is said to have been divorced because she refused to unveil herself publicly at a banquet. It has been suggested that there is some connection between this statement and the fact that Ishtar (Estrā) was called the naked goddess, and was looked upon as the great mother deity and the "queen of heaven." As the Persian king was the earthly representative of heaven, his queen was also styled the queen of heaven and thus probably represented the deity of the same title. Hence the more advanced Biblical scholars have concluded that Esther was never the queen of Xerxes; and that she could have been nothing more than the chief favorite of his harem, if she ever had any real existence.

Notwithstanding this attitude of modern critics, the Jews never had any doubt as to the truth of the Biblical account of the life and doings of Esther, who is credited with delivering the Jewish people from the exactions and cruelty of Xerxes' vizier and effecting the final overthrow of the latter. This belief is as strong to-day as in the past, and the deliverance effected by Esther is still celebrated in the Feast of Purim. Consult the Biblical 'Book of Esther'; ISTHAR; PURIM; and ESTHER, BOOK OF.

**Bibliography.**—Cheyne, 'Founders of Old Testament Criticism' (London 1893); Debaeza, 'Historia Esther'; de Lagarde, 'Purim' (Göttingen 1887); Gunkel, 'Schöpfung und Chaos' (Göttingen 1895); Hughes, 'Esther and her People' (London 1846); Jampel, 'Das Buch Esther'; Nowack, 'Archäologie'; Sayce, 'Introduction to Esther' (London 1885); Toy, 'New World' (Vol. 5, 1887); Tyrwhitt, 'Esther and Ahasuerus' (London 1868).

**ESTHER**, Indian chieftainess. See MONTGOMERY.

**ESTHER**. (1) Drama on the life of Esther, the personage of the Old Testament, written by Racine at the instance of Madame de Maintenon. The pupils of Saint-Cyr performed the drama before King Louis XIV in 1689. (2) An oratorio by Handel based on the drama of Racine, first performed in 1720. The words were by Humphreys.

**ESTHER**, Apocryphal Books of. See APOCRYPHA.

**ESTHER**, Book of. The book of Esther was written for the primary purpose of giving an account of the supposed circumstances of

the origin of the feast of Purim. This was put in the reign of the Persian king Ahasuerus, is certainly to be identified with Xerxes, who reigned from 487 to 466 B.C.

The first question is concerning the historical character of the book. The author had a general acquaintance with Persian customs, and some of the statements made are confirmed from other sources. But some of the details of the book are certainly inaccurate, and many others probably so. Xerxes' queen from the seventh to the twelfth year of his reign was not Esther, as represented in the book, but Amestris, a Persian; no captive of Nebuchadrezzar's was chief minister of Xerxes; and the chronology is incorrect. The book, therefore, is not accurate history; it is probable that there is no historical element in the book. This appears especially from a consideration of the feast of Purim. This is stated in ix, 26, see iii, 7, to have been derived from the presumably Persian word *Pur*, meaning lot. No such Persian word is known. The feast of Purim is first mentioned, under the name of the day of Mordecai, in 2 Maccabees xv, 36, 2 Maccabees being written in the 1st century B.C. This makes it unlikely that the feast was established as early as the time of Xerxes, and hence makes improbable any historical basis for the book. The book, therefore, is of the nature of a romance, giving a current story concerning the origin of the feast.

The actual origin of the feast would seem, therefore, to have been unknown to the writer and his time. This gives a presumption that it was of foreign origin. The indications are that the origin was in Babylonia. The name Mordecai is quite evidently a form of Marduk, the name of the head of the Babylonian pantheon, and Esther is Ishtar, the principal Babylonian goddess. Haman, further, is Humman or Humban, the chief Elamite god, and Vashti is probably to be identified with Mashti, a vaguely known Elamite deity. Originally, therefore, the story seems to have been a myth, giving an account of a conflict between the principal deities of Babylonia and Elam. It is not possible, however, to find any probable identification of the feast of Purim with any known Babylonian feast. The Babylonian account of the feast has here been put into a Jewish form. It is, of course, quite possible that the mythical nature of the story had been obscured before it reached the writer.

The indications point to a late writing of the book. The author was living in the time of the observance of the feast of Purim, which was probably late, as has been indicated. The omission of Esther and Mordecai from the long list of Hebrew worthies in Eccl. xlii-xlix, written about 180 B.C., strongly suggests that the book had not then been written. It has been suggested that the attitude of hostility to the Gentiles which appears in the book might be due to the experiences of persecution by Antiochus Epiphanes. But the absence of any specific references to the Maccabean period makes it probable that the date was before 168 B.C. The language of the book is late, although there are no words which are certainly to be identified as Greek. The author speaks of the reign of Xerxes in a way which indicates that it was long past. It is probable that the book was written after 180 B.C. and before 168.

The absence of the name of God from the book has been the occasion of much perplexity. The explanation has been suggested that it was due to the fact that the book was designed to be read at the celebration of the feast of Purim, this being a festival of such mirth, due principally to drinking, that there would be danger of the profanation of the name of God if it occurred in the reading. The principal religious teaching of the book is that of the providence of God over his people, which is conceived, however, in a spirit of national bigotry. The interest of the writer is not primarily religious but national.

The moral tone of the book is not high. No character portrayed in the book is an admirable one. Esther and Mordecai have the desire for revenge, as well as other qualities rather ignoble than exalted. The book in its general spirit is below the level of most of the Old Testament.

**Bibliography.**—Adeney, W. F., 'Ezra, Nehemiah and Esther' ('Expositor's Bible', New York 1893); Davies, T. W., 'Ezra, Nehemiah and Esther' ('Century Bible', Edinburgh no date); Paton, L. B., 'The Book of Esther' ('International Critical Commentary', New York 1908); Streane, A. W., 'Esther' ('Cambridge Bible', Cambridge 1907).

GEORGE R. BERRY,  
*Professor of Old Testament Interpretation and Semitic Languages, Colgate University.*

**ESTHERIA**, bivalve crustacean of the order of Brachiopods, found as a fossil in fresh water deposits dating from the Devonian to the Pleistocene periods. There are about 24 living species and about the same number of fossil species. In the former the shell is from one-eighth to one inch in length and is rounded and flat with beaks near the hinge. The surface is marked with folds and ridges which serve to distinguish it from the small pelecypods. Consult Jones, 'A Monograph of the Fossil *Estheriæ*' (in 'Monographs of the Palæontological Society,' London 1862).

**ESTHERVILLE**, Iowa, city and county-seat of Emmet County, 140 miles northwest of Des Moines, on the Des Moines River, and on the Minneapolis and Saint Louis and the Chicago, Rock Island and Pacific railroads. It has extensive agricultural and stock raising interests and contains flour mills, grain elevators, railroad repair shops, machine shops, tub factories and cement works. It has also a Carnegie library and a fine school building and owns the waterworks and electric-lighting plants. Pop. 3,404.

**ESTHONIA**, *ës-thõ'nî-a*, Russia, a maritime government, bordering on the Gulf of Finland and the Baltic. On the east is the government of Petrograd; on the south Lake Peipus and the government of Livonia. Most of the territory included in Esthonia is low and swampy or cut up by streams and lakes; and cold, raw winters and hot summers are the rule. Live stock raising and agriculture are the chief occupations of the inhabitants, who are industrious, enterprising and given to the use of modern methods of farming and stock raising. Among the growing industries of Esthonia are machinery, iron and steel, liquors and cotton. Considerable trade is also carried on with neighboring countries and with the

interior of Russia. It includes several islands, of which the most important are Dagoe and Oesel; area, about 7,818 square miles. The peasantry are almost all of Finnish origin and speak a Finnish dialect. In the 10th and 12th centuries it belonged to Denmark; it was afterward annexed by Sweden and in 1710 was seized by Russia. The chief seaport, Reval, which is connected by rail with Petrograd, has extensive shipping. (See REVAL). Pop. 416,580. Consult Vincent, 'Norsk, Lapp, and Finn'; Jordan, 'Beiträge zur Geographie und Statistik Esthlands.'

**ESTHS.** See ESTHONIA.

**ESTIENNE**, ä-tě-ěň, or **ETIENNE** (Lat. STEPHANUS), **Henri**, ôň-rě, French painter and scholar: b. Paris, 1528; d. Lyons, March 1598. He was a son of Robert Estienne (q.v.) and continued his work. Besides compiling the noted 'Thesaurus linguę Gręcę' (1572), he wrote 'Apologie pour Hérodote' (1566); 'Traité de la conformite du Francais avec le Grec', etc.

**ESTIENNE**, or **ETIENNE** (Lat. STEPHANUS), **Robert**, rō-bār, French printer and scholar: b. Paris, 1503; d. Geneva, 7 Sept. 1559. In 1526 he established a printing house in Paris and in 1539 was appointed royal printer to Francis I. He removed to Geneva about 1552. He published many editions of the Greek and Latin classics and compiled numerous other works. His son Henri took up his father's work on the death of the latter and was also a writer of note. He died in Lyons in 1598.

**ESTIVATION**, the dormancy or "summer-sleep," induced in some of the lower plants and animals by heat and drought, and the means by which in summer they resist these unfavorable conditions, as they do others in winter by hibernation. The two states are comparable, though induced by opposite conditions. In summer the principal danger to which such organisms are exposed is the deprivation of water. Some of the lowest are able to endure this to an extreme degree. Certain bacteria and other low plants and various animalcules will survive prolonged baking and may blow about in the dust of dried-up ponds for a long period, ready to revive when dampened. Among land-snails estivation is a common phenomenon, the snails protecting themselves from excessive loss of moisture, not only by burrowing into the ground, but by throwing one or several epiphragms of hardened, sometimes chalky, mucus across the aperture of the shell, thus shutting themselves into an air-tight case, where they remain inactive until better conditions arrive. In a similar manner certain fishes and amphibians bury themselves in the muddy bottom of ponds or river-pools evaporated by drought, where they preserve sufficient dampness about them to keep alive. Turtles, on the other hand, are often compelled to leave their pools in the tropics, because the water becomes so hot and full of fermentation and seek cool spots under rocks, and the like, where they sleep torpidly until autumn. Even a few mammals of extremely hot regions, such as the deserts of Australia, go into a summer-sleep during the height of the hot season, substantially as their congeners hibernate in the midwinter of northern climates. See HIBERNATION.

**ESTLANDER**, **Carl Gustav**, Finnish author: b. 1834; d. 1910. In 1868 he was appointed professor of æsthetics in the University of Helsingfors and in 1876 founded the *Finland Review* of which he became the editor. His many works were of great importance to the artistic literature of his country; they include 'The History of the Plastic Arts from the Middle of the Eighteenth Century to our own Time' (1867); 'The Development Past and Future of the Art and Industry of Finland' (1871); 'Richard Coeur de Lion in History and Poetry' (1858); 'The Robin Hood Ballads' (1889); and researches into the Tristan romance, published in French (1866).

**ESTOC**, a small dagger, known in the 16th century as a "tuckle" and usually worn at the girdle.

**ESTOILE**, or **STAR**, a bearing in heraldry, differing from the mullet in that it has six wavy rays instead of the five plain waves of the latter. See HERALDRY.

**ESTON**, England, town in the North Riding of Yorkshire, four miles east of Middleborough. It has large manufactories of steel rails. Pop. 12,026.

**ESTOPPEL**, the preclusion of a person from asserting a fact by previous conduct, inconsistent therewith, on his own part or the part of those under whom he claims, or by an adjudication upon his rights which he cannot be allowed to call in question; a preclusion, in law, which prevents a man from alleging or denying a fact, in consequence of his own previous act, allegation or denial of a contrary tenor; a plea which neither admits nor denies the facts alleged by the plaintiff, but denies his right to allege them. According to Blackstone, it is a special plea in bar, which happens where a man has done some act or executed some deed which precludes him from averring anything to the contrary. Where a fact has been asserted or admitted for the purpose of influencing the conduct or deriving a benefit from another, so that it cannot be denied without a breach of good faith, the law enforces the rule of good morals as a rule of policy and precludes the party from repudiating his representations or denying his admissions. (Rawle, Cor. 407.)

This doctrine of law gives rise to a kind of pleading that is neither by way of traverse nor of confession and avoidance; that is, a pleading which, waiving any question of fact, relies merely upon the estoppel, and, after stating the previous act, allegation or denial of the opposite party, prays judgment if he shall be received or admitted to aver contrary to what he before said or did. This pleading is called a pleading by way of estoppel. Until a recent period questions regarding estoppel arose almost entirely in relation to transfers of real estate and the rules in regard to one kind of estoppel were quite fully elaborated. The principle is now applied to all cases where one by words or conduct wilfully causes another to believe in the existence of a certain state of things, and induces him to act on that belief or to change his own previous situation.

Estoppels operate not only on present interests, but on rights subsequently acquired. They operate, however, only between parties and privies and the party who pleads the estoppel must be one who was adversely affected



by the act which constitutes the estoppel. An estoppel may be by record, and by record in this connection is meant the record of a tribunal of a judicial character. An admission made in a pleading in a judicial proceeding cannot be contradicted by the person making it. So, ordinarily, the judgment of a court of competent jurisdiction cannot be impeached. If it determines the status of a person or thing, it is binding on all persons, whether rendered by a domestic or a foreign court. Judgments of this character are judgments *in rem*. If the judgment is *in personam*, it is conclusive if rendered by a domestic tribunal, and is conclusive in some instances if rendered by a foreign tribunal. Legislature records also import absolute verity. (Bigelow on Estop. 33.)

An estoppel by deed is such as arises from the provisions of a deed. It is a general rule that a party to a deed is estopped to deny anything stated therein which has operated upon the other party, as the inducement to accept and act under such deed, including a deed made with covenant of warranty, which estops even as to a subsequently acquired title. The deed must be good and valid in its form and execution to create an estoppel, and must convey no title upon which the warranty can operate in case of a covenant.

Estoppels must be reciprocal. An estoppel *in pais*, or equitable estoppel, occurs when a party to an action has by his act or declaration induced the other party to do some act or acts which otherwise would not have been done, or to omit to do some act or acts which he would have done, and by means of which he has been injured. The principle underlying such estoppels is, that it would be a fraud in a party to assert what his previous conduct and admission have denied, when, on the faith of that denial, others have changed their situation. There must, however, as a rule, be some intended deception in the conduct or declarations of the party to be estopped, or such gross negligence on his part as to amount to constructive fraud, by which another has been misled to his injury.

**ESTOTILAND**, a mythical land, placed by the old geographers where are now portions of Newfoundland, Labrador, and that part of British America bordering on Hudson Bay. It was said to have been discovered by two Friesland fishermen driven out of their course by a storm, two centuries before the time of Columbus. In 1497 the Cabots set sail from England for Estotiland, but discovered instead Newfoundland.

**ESTOURNELLES DE CONSTANT**, Paul Henri Benjamin, **BARON D'**, French author: b. La Flèche, Sarthe, 1852. He was educated at the Louis-le-Grand Lyceum, Paris, and at the School of Oriental Languages, joined the diplomatic service, in which he served as secretary to the commission for the boundaries of Montenegro, afterward becoming chargé-d'affaires in that country. He served also at The Hague and in Tunis and London. In 1895-1904 he was deputy from Sarthe and in the latter year was elected senator. He became conspicuous for his advocacy of international peace, was elected member to The Hague conferences and of the international court. His efforts to bring about a better feeling between France and Germany were untir-

ing and in 1909 he was awarded the Nobel prize for peace. He has published frequently in reviews in England, France and America, has written on modern Greece and made translations from the modern Greek tongue, published reports of The Hague conferences and prepared papers for the Parliamentary Union, etc. Other works are 'Les congregations religieuses chez les Arabes' (1887); 'La politique française en Tunisie' (1891); and 'Les Etats-Unis d'Amerique' (1913), an account of his impressions during his visits to America in 1902, 1907, 1911 and 1912.

**ESTOVERS**, in law, (1) wood which a tenant may legally use, as for repairs or firewood. It is a principle of both English and American law. It includes to-day, in the absence of express covenants to the contrary, any wood which a tenant for life, for years, from year to year, or at will may use from the estate to repair the house, fences, implements, etc., thereon, in addition to that which he uses for fuel. (2) Formerly, alimony allowed a divorced wife; also, a widow's allowance.

**ESTRADA**, Spain, town in the province of Pontevedra, 15 miles southeast of Santiago de Compostela, on the Ulla. It has extensive agricultural and stock raising interests and contains lumber yards and manufactories of linens and woolens. Mineral springs are in the neighborhood. Pop. (commune) 27,898.

**ESTRADA CABRERA**, Manuel, Guatemalan statesman: b. Quezaltenago, 1857. At first he devoted himself to the study of law and philosophy and practised his profession. He was appointed district judge and finally attained the supreme bench. About 1885 he began to take an active interest in politics and was elected to the National Assembly; he was appointed Secretary of State in 1892 and six years later, on the assassination of President Barrios, became acting President. Within a few months he was elected to a full presidential term and secured re-election for a second term in 1905. His administration was very progressive; he did much to place the finances on a sound basis, promoted agricultural and industrial enterprises, aided education and promoted in general the well-being of his country. Several attempts were made on his life by the bitter enemies he had made. For the third time he was elected to the presidential chair in 1911.

**ESTRADES**, Godefroi, **COMTE D'**, French soldier: b. Agen, 1607; d. 1686. He served as a page at the court of Louis XIII and in 1646 was sent to Holland on a special mission. He was commissioned a colonel of infantry and in 1647 was made field marshal. He was sent as Ambassador Extraordinary to England in 1661 to negotiate the cession of Dunkirk to France; he also served as ambassador to Holland and distinguished himself at Wesel and Liege. In 1678 he represented France at the Peace of Nymwegen. His 'Lettres, Memoires et negotiations' (9 vols., Paris 1758, and a tenth volume, London 1763) were published after death. Consult Lauzun, Philippe, 'Le Mareschal d'Estrades' (Agen 1896).

**ESTRAY**, in law, any animal not *fera nature* and the subject of property which is found at large without ostensible owner in any place other than the land of the owner. If

found on private land such animal in most jurisdictions may be impounded at the cost of the owner. In England an estray becomes subject to the lord of the manor who acquires a right therein which becomes absolute in case the animal is not reclaimed by the owner after due proclamation by the lord of the manor. In some States the finder of an estray may after due advertisement sell same at public or private sale and the purchaser will acquire a good title therein. The proceeds of the sale after the finder's expenses have been deducted are as a general rule paid into the town treasury. Consult Burn, 'Justice of the Peace and Parish Officer' (30th ed., London 1869).

**ESTREAT**, in law, a copy or extract of an original record, particularly of fines: common in the phrase *estreat of a recognizance*, or the removing of such recognizance from among the other court records and sending it to the exchequer to be enforced. In England, if a recognizance is forfeited by violation of a condition, it is estrated, whereupon the parties become indebted to the Crown to the amount named in the recognizance.

**ESTREES, Gabrielle d'**, French court favorite and mistress of Henry IV: b. about 1573; d. 1599. She was the daughter of the Marquis Antoine d'Estrees, Governor of L'Isle de France. In 1590 she met Henry IV at her father's castle and he fell a slave to her charms. Her father, having learned of the king's infatuation and fearing a scandal, forced Gabrielle into a marriage with M. d'Amerval de Liancourt but the king annulled the marriage and called her to court. Henry made her Marchioness of Monceaux and Duchess of Beaufort. She had several children by Henry and was the recipient of the greatest favors at his hand. To make her queen he even had in mind to divorce Margaret of Valois and was only hindered from so doing by the sudden death of Gabrielle. Consult Desclozeaux, 'Gabrielle d'Estrees' (Paris 1889).

**ESTRELLA DE SEVILLA**, a comedy of Lope de Vega, which by many critics is considered his best work.

**ESTREMADURA**, ɛsh-tra-mā-doo'ra, Portugal, maritime province divided by the Tagus into two nearly equal parts, of which the north is the more mountainous. Wines and olives are the principal products. The chief city is Lisbon. Area, 6,876 square miles. Pop. 1,438,726.

**ESTREMADURA**, ă-strā-mā-doo'ra, a division of southwestern Spain, consisting of two provinces, Badajoz and Cáceres. The northern part has large forests, and in the central and southern parts are some good agricultural lands. Deposits of coal, copper and silver are found in the mountains; but the mines are not well developed. Area, 16,162 square miles. Pop. 990,990.

**ESTREMOZ**, Portugal, town in Alemtejo province, 30 miles northeast of Avora. It is 1,500 feet above sea-level and contains the ruins of two ancient forts. The porous clay of the district is much used in the manufacture of the earthenware which has made Estremoz famous throughout the peninsula. Wool is exported in large quantities from here and marble of varied color is quarried nearby. Pop. 7,857.

**ESTREPEMENT**, the waste of lands committed by a tenant, in which sense the word has been supplanted by the term "waste." It survives, however, as the name of an ancient writ of common law to restrain the commission of waste. In most modern jurisdictions the writ has become obsolete through the development of the functions of the courts of equity, but it still exists in Pennsylvania, where there are no courts of equity, as a remedy for the prevention of waste.

**ESTRUP, Jacob Bronnum**, Danish statesman: b. Soro, 1825; d. 1913. He was elected to the Landsting in 1864 and in due time became leader of the Agrarians, and also was active in the preparation of the new constitution of 1866. He served as Minister of the Interior in 1865-69 and did much to improve the railway service of the country. He was chosen president of the council in 1875 and at the same time accepted the portfolio of Minister of Finance. After 1877 he acted very arbitrarily in issuing provisional acts and for several years, from 1885 to 1894, financed the government through provisional budgets. All this involved him in difficulties with the Folkething and his resignation in 1894 may be said to mark the passing of power from the upper house to the lower. He soon lost his influence and his opposition to the sale of the Danish West Indies in 1902 and later to electoral and tax reforms were little heeded.

**ESTSÁNATLEHI**, the ever-self-renewing goddess of the Navajos, wife of the sun and mother of the two war gods. See NAMOUNA.

**ESTUARINE DEPOSITS**, sediments laid down in estuaries along a coast. They are frequently formed on great mud flats or tidal flats that are above the ocean water part of the time and part of the time submerged. As a result they often partake both of the nature of marine sediments (q.v.) and of terrestrial sediments (q.v.).

**ESTUARY**. Where a shore-line is sinking or has been recently depressed, the rivers, unless large and heavily charged with sediments, have their valleys drained by the encroaching sea, forming roughly funnel-shaped bays. Such bays are called estuaries and are common along the sinking Atlantic Coast of North America. Illustrations are seen in Passamaquoddy and Narragansett bays, the mouth of the Hudson River, Delaware and Chesapeake bays. Owing to their shape, estuaries frequently have strong tidal currents, due to the height of the tides, and the rising tide rushes in as waves, the most remarkable examples of such surf-like tidal waves, or bores, being found in the Bay of Fundy. The rivers entering estuaries drop much of their fine sediment there because of the checking of their currents and the precipitating effect of salt water. The strong tidal currents sweep away and rearrange these sediments. Hence conditions on the bottoms of estuaries are often unfavorable for the growth of organisms, and the estuary deposits of past ages are seldom rich in fossils, but may contain remains of land organisms brought down by the old river; and the tidal mud-flats have preserved the prints of raindrops, the traces of worms and the tracks of birds and reptiles. See RIVERS.

**ESZEK**, es'sék, or **ESSEG**, Austria-Hungary, royal free city in Croatia and Slavonia, capital of the county of Virovitica, on the Drave, about 63 miles west-northwest of Peterwardein. It consists of the town proper, partially fortified, and three suburbs, and is the seat of an appeal court for three centuries. Its public buildings of note are the Capuchin and Franciscan monasteries, the town hall, county court building, and commandant's residence, a gymnasium, and training school for teachers. It has manufactures of flour, silk goods, leather, glass, etc. There is a considerable trade in grain and meat and other products of the district. The four annual fairs, chiefly for corn, cattle and hides, are important. As a Roman colony, founded by the Emperor Adrian, under the name of Mursia, it became the capital of Lower Pannonia, and in 335 was made a bishop's see by Constantine. In 1848 the Hungarians under Batthyányi, held out for some time in this city before submitting to the Austrians. Pop. 31,388, mostly Germans.

**ESZTERGOM**, Hungary, royal free town and capital of the county of Esztergom, 25 miles northwest of Budapest, on the Danube. Agriculture is the principal industry of the inhabitants and there is a large trade in wine. It has manufactures of brick and ironware and hot medicinal springs have made it a health resort. The town is the seat of the Prince Primate of Hungary; its handsome cathedral has a dome like Saint Peter's, Rome, and is an imposing structure in the Italian Renaissance style. Another noteworthy church is Saint Anne's and the primate's palaces, the ecclesiastical seminary, the museum, gymnasium and town hall are well deserving of notice. In the cathedral is a library of 113,000 volumes and many manuscripts, some of which are invaluable. The town is one of the oldest in Hungary; here was borne Saint Stephen, the first king of Hungary, who established a bishop's see here soon after his conversion in the year 1000. It was long of importance as a commercial centre, but its destruction by the Tatars in 1241 caused its decline and it never regained its former splendor. From 1543 to 1683 it was in possession of the Turks. Pop. 17,881.

**ESZTERHAZY**, ăs-tăr-ă-zê, or ăs'tër-hă-zî, Marie Charles Ferdinand Walsin, forger: b. Austria, 16 Dec. 1847. He served in a regiment of Papal Zouaves during the latter part of the French Empire; was promoted commander, a rank equivalent to major in other armies, in 1892. In the early part of 1897 he was retired from the army. He became notorious through his connection with the trial of Capt. Alfred Dreyfus (q.v.), whom he accused as being the writer of the famous "bordereau," alleged to have been sent to certain German military officers revealing French military secrets. In December 1894 Dreyfus was tried by court-martial and convicted as the author of the document, and on 5 Jan. 1895 was publicly degraded and a little later sent as a prisoner to Devil's Island. In 1896 Colonel Picquart, the head of the intelligence bureau of the war office, made certain discoveries which pointed to Major Eszterhazy as the author of the "bordereau." These discoveries led to further investigation and Dreyfus was brought from his prison and given a new trial in 1899, but was again convicted, al-

though much of the evidence gathered pointed to Eszterhazy as the forger of Dreyfus's handwriting and as the real traitor. So strong did this opinion become that Eszterhazy was compelled to leave France.

**ESZTERHAZY VON GALANTHA**, ăs'tër-hă-zî fôn gă-lăn'tă, a family of Hungarian magnates, afterward princes of the German Empire, whose authentic genealogy goes back to the first half of the 13th century. They were zealous partisans of the House of Hapsburg, to whom, during the reigns of Frederick II and Leopold I, they lent a powerful support. In 1238 Peter and Elias, sons of Salomon von Estoras, divided their father's inheritance. The former obtained Zerhaz, the latter Illyeshaza, and thus became the founders of two principal lines, the latter of which became extinct in the male line in 1838, with Count Stephen Illyeshazy. Peter's descendants took from their domain the name of Zerhazy, till Francis Zerhazy (b. 1563; d. 1595), vice-regent of the county of Presburg, changed his name into Eszterhazy in 1584, on the occasion of his being named Lord of Galantha. Among noted modern inheritors of the name are PAUL IV, PRINCE ESZTERHAZY, a general and literary savant (1635-1713). His grandson, NICHOLAS JOSEPH, a great patron of arts and music, founder of the school in which Haydn and Pleyel, among others, were formed (1714-90); NICHOLAS, PRINCE ESZTERHAZY, distinguished as a field marshal and foreign ambassador (1765-1833); PRINCE PAUL ANTHONY, a distinguished and able diplomatist (1786-1866), successively Austrian ambassador at Dresden, Rome, and Britain, and a supporter of the National Hungarian movement.

**ETA**, or **AETA**. See **NEGRITOS**.

**ETAMPES**, Anne de Pisseleu, ăn dè pês-sê-lê ă-tănp, DUCHESSE D', French royal favorite: b. about 1508; d. 1585. She became the mistress of Francis I to whose mother she had been maid of honor, but to save appearances he gave her for a nominal husband Jean de Brosse, afterward Duke d'Etampes. The new duchess wielded a paramount influence in the affairs of the nation. Upon the fine arts and in some other directions she exerted a good influence, but the jealousy between her and Diana of Poitiers, the mistress of the Dauphin Henry, became a source of calamity for France. It was chiefly under the influence of this feeling that she betrayed to Charles V the movements of the French army; and the disadvantageous treaty of Crécy in 1544 was due to the intrigues of Anne and of Diana. On the accession of the Dauphin Henry to the throne in 1547 the Duchesse d'Etampes was banished from court. She retired to her extensive estates where she became interested in the Protestant cause and greatly aided the Huguenots. She is said to have been very beautiful, highly educated, and to have been possessed of more than ordinary intelligence.

**ETAMPES** (ancient **STAMPÆ**), France, a town in the department of the Seine-et-Oise, at the confluence of the Etampes and Juine, 32 miles southwest of Paris. It has four Gothic churches, one of them a remarkable structure of the 13th century; tanneries and bleacheries, and a considerable trade in corn, flour and prepared wool and garden produce. Pop. 9,454.

**ETANG**, ā-tān, a French geographical term applied to the remarkable salt lagoons and marshes on the south and west coasts of France. The stagnant seawater is generally utilized, as in Brittany and in the department of Bouches-de-Rhone, for the manufacture of salt. The principal lagoons of this character in France are the Etangs de Berre, de Sigean, de la Palme, and de Leucate on the south, and de Heurtin, de Cazan and de Parentes on the west coast.

**ETAWAH**, ẽtā'wā, India, town in the northwest provinces, 70 miles southeast of Agra, capital of the district of Etawah, situated on the left bank of the Jumna River. It was once the residence of many of the Mogul grandees, and it is now an important trade centre. Pop. 45,350.

**ETCHEMIN.** See MALECITE.

**ETCHING: ITS TECHNIQUE AND GREAT MASTERS.** An etching is the *proof* or picture an artist obtains by printing from a prepared plate of copper or zinc on which the lines and forms of a subject had been scratched by him and then *bitten-in* by the action of an acid. It is evident that to produce satisfactory work, the etcher must be a good draughtsman, must have an active imagination, and a keen knowledge of the technique of etching and printing. He must, moreover, be acquainted with the works of the masters of the art. In this article, therefore, the various processes used in producing an etching will first be described, and then the works of the master-etchers will be reviewed.

#### I. TECHNIQUE OF ETCHING.

**Materials Employed in Etching.**—The following articles which can be procured at any artists' supplies store are now generally used in the practice of the art:

Copper plates	Etching-ground
Etching needles	Stopping-out varnish
Burnisher	Nitric acid
Scraper	Turpentine
Dabber	Wax tapers
Roller	Charcoal
Hand-vice	Crocus powder
Porcelain trays	Tracing paper
Acid hydrometer	Emery paper
Plate-warmer	Whitening

**The Processes of Etching.**—The several steps taken in the production of an etching embrace: grounding and smoking the plate; marking the outline; biting-in by means of an acid; and printing.

**Method of Grounding and Smoking the Plate.**—After thoroughly cleaning the plate—first with turpentine and a soft clean rag, and then with a little whitening—a hand-vice is firmly screwed on to the middle of one of its long edges. To prevent the jaws of the vise from scratching the surface of the plate, a piece of thin cardboard is inserted between them and the plate.

The plate is then uniformly heated throughout over the flame of a small gas jet or spirit-lamp and is covered with what is known as *etching-ground*—a gummy preparation in the form of a ball, wrapped in a piece of silk, and composed of mastic gum 30 parts; white wax 30 parts; and asphaltum 15 parts.

As it is desirable that the ground be spread over the plate in an even and thin film, it is dabbed all over with the *dabber*. This tool consists of a circular pad of horse-hair with card-

board backing, enveloped in two wrappers, an inner one of cotton-wool, and an outer one of silk fabric, the latter stretched tight, gathered and tied in the back to form a handle.

The next step is to smoke the ground. The plate is again evenly heated and then held over a flame of three or four wax tapers twisted together. Care must be taken to have only the tip of the flame touch the ground, while the plate is kept constantly in motion, until the whole ground is blackened. The etcher must also see to it that the flame is not playing too long on the same spot of the ground or it will be burnt. When an area of the ground, no matter how small, does get scorched, the whole ground becomes useless. After the process of smoking is completed, the back of the plate is covered with some stopping-out varnish, to protect it against the action of the acid during the subsequent process of etching. When the plate has been prepared in the manner described, it is ready to receive the outline.

**Method of Marking the Outline on the Ground.**—A careful drawing of the subject, the size of the plate, is first made on ordinary paper, from which a tracing is made on tracing paper. After rubbing some lead on the back of this tracing, it is fastened, face upward, to the smoked ground of the plate; and with a hard pencil the outline is gone over, pressing lightly. Upon removing the paper from the plate, the lines will be found transferred to its surface. On this pencil impression as a guide, the etcher next freely redraws the subject with an etching needle, putting into it all the art at his command as regards beauty of line, form and composition generally.

The needles used to etch with are generally made for the purpose, and may be held in a handle specially contrived. A needle with a fine oval-shaped point is used for putting in the delicate lines, such as are required in the treatment of skies or distances; and one with a blunt point for the deeper lines. The point is used with sufficient pressure to remove the ground, expose and faintly scratch the bare copper along its track. This faint outline, made by the needle, is then *bitten-in* to the required depth by immersing the plate in a porcelain tray containing an acid solution, called a *mordant*.

**The Mordants Used in Etching.**—The two mordants now generally used are the nitric and the hydrochloric acid baths. The nitric mordant is composed of nitric acid equally diluted with water. The hydrochloric bath, known as the Dutch mordant, is composed of chlorate of potash, 2 parts; hydrochloric acid, 10 parts; and pure water, 88 parts. The nitric mordant is more liable to vary in its action than the hydrochloric; but it has the great advantage of being decidedly more rapid, thus affording the artist the opportunity of watching the process of biting and checking it when necessary. For this reason, it is preferred by many etchers.

The action of either mordant may be retarded or accelerated by the varying conditions of the weather; it is advisable, therefore, to keep it at a uniform temperature (about 60° Fahrenheit) throughout the biting. This is best regulated by performing the etching on a *plate-warmer*—an iron box with gas-jets beneath.

**Method of Biting-in the Sketch.**—There are two methods now used in etching the plate. One way is by the process of *stopping-out*. The

ETCHING

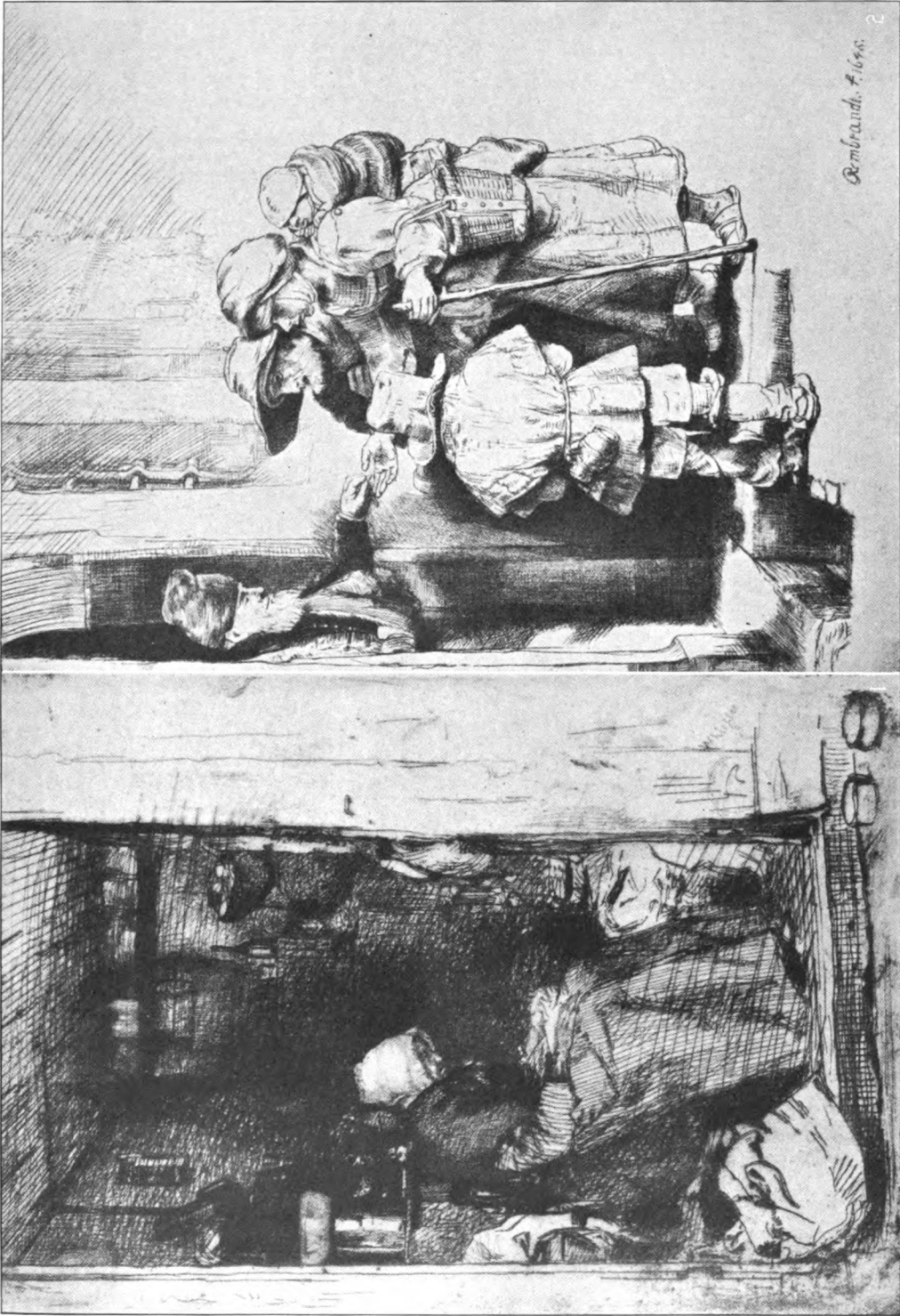

1 La Vieille aux Loques (Whistler)

2 A Group of Beggars (Rembrandt)



plate is immersed in the acid bath for about five minutes, if in the nitric mordant and three times as long in the hydrochloric. This will suffice for the lightest tints to be bitten-in. After withdrawing the plate from the bath, it is washed, and dried between blotters, and the light lines are painted over with *stopping-out varnish*—a combination of resin dissolved in turpentine to which a little lamp-black had been added.

When dry, the plate is returned to the bath and kept there for about 10 minutes. As after the first biting, the plate is again taken out, washed, dried and the next deeper tones stopped-out. The process is repeated four or five times until the darkest tints have been produced. About 30 minutes in the nitric mordant is sufficient to bite-in the deepest lines.

A more satisfactory way of etching the plate consists in taking several different proofs during the process of biting. This method is as follows: The etcher makes his drawing on the grounded plate with the needle, putting in only the lines representing the middle and dark tones, and leaving the light lines for subsequent treatment. The plate is immersed in the mordant for about 15 minutes—just long enough to bite-in the middle tint. After removing the ground with turpentine and thoroughly cleaning it, a proof is taken and the parts intended to be darker are rebitten in the same lines. This of course necessitates the regrounding of the plate without filling up the lines already bitten-in. To accomplish this, a very thin film of ground is spread upon another heated plate, and the roller, thinly charged with it, is lightly passed over the etched plate, also warmed for the purpose. When the plate has been rebitten, another proof is taken, and if the middle tint then proves to be satisfactory, successive bitings are made, and proofs taken to obtain the dark tones. The middle and dark tones settled, the etcher next completely covers the plate with transparent etching-ground or stopping-out varnish so as to fill up the lines and protect the spaces between them, and draws in the delicate lines intended to represent the pale tints. These are bitten-in and the final proofs taken.

*Correcting Processes.*—Light lines that have been over-bitten may be reduced by rubbing with a piece of charcoal moistened with olive oil. Deep erasures are made with the *scraper*—a kind of a knife, triangular in section, and coming to a point. The polished surface in an erased area is regained by the use of the *burnisher*—a polished tool, made of steel and tapering to a point. The burnisher is also used to slightly reduce an over-bitten passage by rubbing it on the plate, pressing, thereby, the copper more together into the lines.

*Auxiliary Processes.*—Etched plates are frequently finished and enriched with what are known as *dry-point* and *soft ground etching*. Dry-point is the name given to a form of engraving in which the lines are cut directly into the *dry* plate by means of the needle, and without the use of a mordant. It is remarkable for yielding rich and velvety proofs, which is due to the *burr* or rough edge of the copper, produced by the point as it cuts the plate. Dry-point is employed to deepen foreground tones, and with the burr removed by means of the scraper) it is also useful for putting in the delicate markings in a composition. Prints are

often made of plates produced entirely by dry-point. In soft ground etching, the plate is covered with etching-ground mixed with tallow, to prevent it from hardening, and a piece of slightly rough paper is laid over it on which the artist makes his drawing with a lead pencil. When the paper is removed it brings off with it etching-ground, exposing the copper in such a manner that when bitten-in and printed, the plate will yield a proof having much of the quality of a pencil drawing.

*Method of Printing.*—The apparatus and articles necessary for printing include:

A printing press	Printer's canvas
A plate-warmer	Soft old muslin
Printing ink	Whitening
A printer's dabber	Paper
A palette knife	Printer's blankets

Proofs are made from the etched plate in the following manner: After thoroughly cleaning it, first with turpentine and then with a little olive oil, the printer, by means of the dabber, covers the whole plate with thick oily ink, usually of a brownish tint, taking care to fill up the lines. With coarse canvas he then wipes out the superfluous ink from the surface. In that portion of the sketch where a sombre and mysterious effect is desired, he allows a thin film of the ink to remain on the surface of the plate; in another part which should be light, sharp and vivid, he wipes the surface of the plate dry and clean until it shines. In an area where the lines should be soft and velvety, he draws the ink out of the lines and over their edges by means of a piece of soft old muslin. When the plate has been inked and wiped it is laid face upwards on the platform of the press upon which had been first spread several printing blankets of soft woolen cloth. A dampened piece of Japan paper or vellum is then laid over the plate and covered with more blankets. The press is slowly set in motion, and the plate, covered by the paper and blankets, passes under the heavy revolving roller. The pressure causes the inked lines and tones in the plate to be transferred to the paper.

## II. THE GREAT MASTERS OF ETCHING.

Of all the graphic and plastic arts, the art of etching has always had a profound fascination for the true artist, painter or sculptor. When weary of the more exacting arts of painting or sculpture, he frequently finds diversion in the joys of handling the copper plate and etching needle. Since the early part of the 16th century when etching was originated, it has steadily risen into high artistic favor, so that now some of the very greatest names in the art history of England, France, Germany, Holland, Spain and the United States appear in the list of those who have enriched the world with improvisations in this medium.

*Etching in England.*—England has produced many great painter-etchers. The most significant are Turner, Haden and Brangwyn. In the etchings of J. M. W. Turner (1775–1851) which were published in his 'Liber Studiorum,' he makes the same appeal to the imagination as in his famous paintings, by casting an indefinable glamor over the bits of nature he interpreted. Technically, he was remarkable for having the power of selecting the main lines of a subject which he rendered boldly, depending upon mezzotinting for the delicate

tones. Sir Francis Seymour Haden (1818-1913), who was a London physician professionally, practised the art of etching merely as a pastime. Nevertheless, he ranks as one of the greatest of modern landscape etchers. He was very skilful in depicting the poetry of still waters, the movement of clouds, and the beauty of trees, silhouetted against the sky. On purely technical grounds he is incomparable, having invented several processes which he employed in the production of his works. His masterpieces for which he was knighted by his sovereign are 'The Agamemnon,' 'Whistler's House' and 'Harlech.' Frank Brangwyn, although still a young man, has already won for himself first rank among the British contemporary painters and etchers. His prints of Italian, French and English subjects are famous for vigor of handling, rich blacks, and clever adjustment of tones.

**Etching in France.**—France has given the world a legion of etchers, including Claude Lorrain, Delacroix, Daubigny, Jacque, Millet, Jacquemart, Méryon and Legros. But all of these have attained greater fame in painting, with the exception of Méryon and Legros, who rank very high as etchers pure and simple. Charles Méryon (1821-68) etched for the most part the quaint old buildings and streets of Old Paris, depicting them with such depth of poetic feeling that they give one the same overwhelming sensation that he experiences in list-



Le Petit Pont (Méryon)

ening to Beethoven's 'Heroic Symphony' or in viewing Michael Angelo's 'Day.' His etchings are indeed the sublime expression of a great and inspired soul. And yet, this rare genius was so little appreciated during his lifetime that his finest proofs sold for only 30 cents each. He took this public indifference much to heart, and

one day, in a moment of despair, he destroyed some of his most magnificent plates. Finally, through adverse fortune, he became mentally unbalanced and died in an insane asylum. And now that the master is at rest, some of his proofs sell for thousands of dollars each. Alphonse Legros (1837) has produced etchings

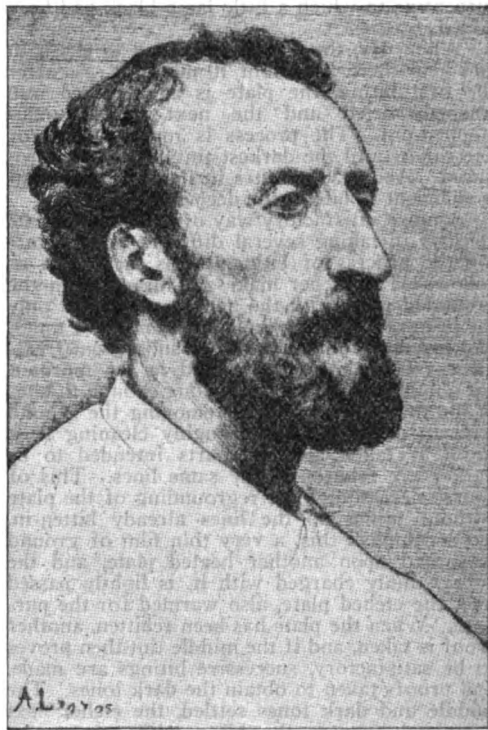

Portrait of Dalou (Legros)

which are austere and gloomy in sentiment and simple in execution. His portrait of the sculptor Dalou and 'The Death of the Vagabond' are considered his best prints.

**Dürer and Etching in Germany.**—The great pictorial genius of Germany is Albrecht Dürer (1471-1528) who excelled in painting, engraving and etching. He was among the first to practise the art of etching in which, as in the other arts, he shows himself a man of intense seriousness, of powerful but somewhat morbid imagination, and of a philosophical turn of mind. His best work in this medium is 'Saint Jerome,' etched in 1512 and now in the British Museum.

**Etching in Holland.**—The painters of Holland who also practiced the art of etching are Ostade, Paul Potter, Ruysdæl, Everdingen and Rembrandt Van Ryn (1606-69), the greatest painter and etcher who has ever lived. It is common knowledge that he was a great painter, but many are the critics who are of the opinion that he is even greater as an etcher. This "Wizard of the North," as Rembrandt has been called, was a robust and versatile genius, having such keen powers of observation and great technical skill, that with a few lines he could depict the life history of a human being or the spirit of a landscape. The subjects of his etch-



ings range from the humble and lowly to the majestic and sublime; from 'A Group of Beggars' to 'Christ Healing the Sick'; but in all we feel the same master hand and mind.

**Etching in Spain.**—The one artist in the history of Spanish art who has especially distinguished himself as an etcher is Francisco de Goya (1746–1828). He was a man of great physical energy and courage, and an open revolutionary in religion and politics; but possessed of a morbid imagination. All these personal characteristics found expression in his etchings which he produced in several series. The most noted are 'The Caprices' (80 plates), which have an important philosophical bearing; and 'Disasters of War' (80 plates), with which he tried to make men disgusted with war.

**Etching in the United States.**—The art of etching in the United States was first practised by William Dunlap about 1830. Since then very many painter-etchers have appeared, including Peter Moran, Farrer, Falconer, Gifford, Smilie, Parish, Church, Bacher, Whistler and Pennell. Of these, Whistler and Pennell have won international fame. James A. McNeill Whistler (1834–1903) as an etcher is ranked with Rembrandt and Méryon. His subjects include figure compositions, Holland, Venetian and Paris street scenes and London wharves, which he etched with consummate skill and refinement. Of his street scenes, his most famous are 'A Street at Savern' and 'The Unsafe Tenement.' His 'La Vieille aux Loques' is considered his best figure print. Joseph Pennell (1860—) has etched a series of plates of Spanish, Italian, London, Philadelphia and New York subjects, which are remarkable for spontaneity and spirited execution. His proofs of the New York 'sky-scrapers' are particularly famous. See ENGRAVING.

A. G. SCHULMAN,  
*Department of Art, College City of New York.*

**ETCHMIADSIN**, a celebrated Armenian monastery in the Transcaucasian province of Erivan, 10 miles west of Erivan. It consists of three groups of buildings, surrounded by a high brick wall and from a distance has the appearance of a fortress. It contains a theological seminary, a library, with Armenian manuscripts, and several churches, of which the Shoghakath is said to have been founded by Saint Gregory. It has a Byzantine cupola and its walls are decorated in Persian style. The monastery is the seat of the Armenian primate and since the Russian occupation also of the Armenian Holy Synod. The monastery was founded in the 6th century and was ceded to Russia after the Russo-Persian War of 1827.

**ETEOCLES**, ɛ-tē'ō-klēz, and **POLYNICES**, pōl-i-nī'sēz, two heroes of ancient Greek legend, sons of Œdipus, king of Thebes. After their father's banishment from Thebes, Eteocles usurped the throne to the exclusion of his brother, whom he drove from Thebes, an act which led to what was known as "The Expedition of the Seven Against Thebes." Polynices being one of the seven leaders. Polynices went to the court of Adrastus, king of Argos. There he married the daughter of the latter and induced his father-in-law to help him against Thebes. The two brothers fell by each other's hand. The interment of Polynices was forbidden under penalty of death, but Antigone

(q.v.), his sister, braved the doom decreed. Racine has dramatized this story with some poetical variations in his 'Frères Ennemis,' but the story was famous long before he took it up, having already played a part in Greek epic second only to that of the Siege of Troy. Æschylus used it in his 'The Seven Against Thebes,' and Euripides in his 'Phœnissæ' while it enters into the story plot of other Greek writings. Consult Bethe, 'Thebanische Heldenlieder' (Leipzig 1891). See ADRASTUS.

**ETERNAL CITY**, The, Rome, the capital of Italy. Legend states that it was raised by or under the immediate supervision of the immortal gods. The term is frequently to be met in classic literature. 'Ave, Roma Immortalis' is the title of a historical work on the Italian capital, by Francis Marion Crawford. 'The Eternal City' is the title of a novel by Hall Caine, published in 1901, the scene of which is laid in Rome. It was dramatized and produced simultaneously in England and in the United States in 1902. (See ROME). Consult Moore, F. G., 'Urbs Æterna and Urbs Sacra' (*Transactions of the American Philosophical Association*, Vol. 25, 1894).

**ETERNITY**, Cape, headland on the left bank of the Saguenay River, Canada, about 40 miles up the river. It has an elevation of about 1,800 feet and is a prominent feature of the landscape.

**ETESIAN WINDS**, winds blowing at stated times of the year; applied especially to north and northeast winds which prevail at certain seasons in the Mediterranean regions. They are due to the heat of the African Sahara, which causes a huge displacement of air due to superheating. This is supplied by the cooler air from Southern Europe.

**ETEX**, Antoine, ăn-twān ă'téks, French sculptor, painter, architect, engraver and writer: b. Paris, 20 March 1808; d. Chaville, 16 July 1888. He studied under Ingres, Dupaty, Pradier and Duban. He took the second grand prize of Rome (1829) with his 'Dying Hyacinthe'; and became a member of the Legion of Honor (1841). Among his other works in sculpture are 'Cain and His Cursed Race' (1833); 'Resistance of France to Coalition of 1814,' and 'Peace,' for the Arc de l'Etoile; group, 'City of Paris Imploring God for Victims of Cholera'; 'Charlemagne'; equestrian statue of Charles I. Among his paintings are 'Romeo and Juliet'; 'Faust and Marguerite'; 'Allegorical Glory of the United States,' for City Hall, New York (1853). Among his literary works are 'Notes on Paul Delaroché' (1857); 'Study of Life and Works of Ary Schæffer' (1859); 'Textbook for the Polytechnical Association, for Students and Workmen' (1861).

**ETHANE**, C<sub>2</sub>H<sub>6</sub>, a gaseous hydrocarbon belonging to the paraffin series and constituting its second member (the first being methane, or marsh-gas). It occurs in the gases that are given off by crude petroleum, and it may be prepared by heating methyl iodide with metallic zinc in closed tubes at 300° F.; the iodide of methyl that is required being obtained by acting upon methyl alcohol (see ALCOHOL) with iodine, in the presence of phosphorus. Ethane is also liberated at the anode, together with carbon dioxide in the electrolysis of a concen-

trated solution of sodium acetate. It is a colorless gas, which burns with a pale flame and combines with water, under pressure, to form a crystalline hydrate. Chlorine combines with ethane rapidly, in diffuse daylight, with the formation of ethyl chlorid,  $C_2H_5Cl$ ; but if excess of chlorine is present, higher substitution products are also formed, terminating with hexachlorethane,  $C_2Cl_6$ . Ethane is also known as "ethyl hydrid."

**ETHE, (Karl) Hermann**, German Oriental scholar: b. Stralsund 1844. He received his education at the universities of Greifswald and Leipzig. In 1867 he was appointed privatdozent in Arabic, Persian and Turkish in Munich. Five years later he visited Oxford for the purpose of cataloguing the Oriental manuscripts in the Bodleian Library there, the first volume of his catalogue making its appearance in 1889. He was made professor of German and Oriental languages at University College, Aberystwyth, Wales, in 1875. His varied labors include a catalogue of the Persian documents in the India office library, a critical text of 'Yüsuf and Zalikhâ' (1908); 'Grundriss der ivanischen Philologie,' and articles on professional topics in the *Athenæum*, etc.

**ETHELBALD, or ÆTHELBALD**, king of Mercia: b. date unknown; d. 757. He was the son of Alweo and succeeded to the throne after the death of Ceolred in 516. Within 15 years he succeeded in making subject to him all the princes and peoples of the southern and central parts of England as far as the Humber. In 740 he invaded Northumbria and two years later led a successful campaign against the Welsh. In 752 he was vanquished at Burford by Cuthred, king of the West Saxons. It is supposed that Ethelbald was murdered by his guards. Consult Green, 'Conquest of England' (New York 1884).

**ETHELBALD**, king of Wessex: d. 860. He was a son of Ethelwulf, king of the Anglo-Saxons; was present with his father at the victory over the Danes at Ockley in 851, and obtained the throne of Wessex in 856. While Ethelwulf was making a journey to Rome, Ethelbald formed the project of seizing the throne. A civil war was prevented only by the moderation of Ethelwulf, who resigned to his son the dominion of Wessex and confirmed that portion of the kingdom to him in his will. The reign of Ethelbald was peaceful, but he excited general disapprobation by marrying, contrary to the canonical law, his stepmother, Judith.

**ETHELBERT**, king of Kent: b. about 552; d. 616. He married Bertha, the daughter of Charibert, king of the Franks, and a Christian princess, who, stipulating for free exercise of her religion, brought over with her a Frankish bishop. Her conduct was so exemplary as to prepossess the king and his court in favor of the Christian religion. In consequence, Pope Gregory the Great sent a mission of 40 monks, headed by Augustine, to preach the gospel to the Saxons (597). They were well received and numbers were converted; and the king himself at length submitted to be baptized. Civilization and knowledge followed Christianity, and Ethelbert, about 600, enacted a body of laws, which was the first written code promul-

gated by the northern conquerors. At the time of the landing of Augustine he had acquired a supremacy over all the English south of the Humber. Ethelbert founded the see of Rochester in 604 and built the first cathedral, and afterward that of London, and built the church of Saint Paul. He was succeeded by his son, Eadbald.

**ETHELBERT**, king of Kent and Wessex: d. 866. He was the third son of Ethelwulf and succeeded to the government of Kent about 855, and in 860, on the death of his brother, Ethelbald, became king of Wessex. His reign was much disturbed by the inroads of the Danes and Gaulish pirates, whom he repulsed with vigor, but without permanent success as, whenever they were driven from one part of the country, they ravaged another.

**ETHELFLEDA, or ÆTHEFLA' ED**, eldest daughter of Alfred the Great, king of England, and often referred to as the Lady of the Mercians. She was born about 870; d. Tamworth, 12 June 918. In 886 she was married to Aethelred, Earl of Mercia, and with him she held Mercia when her brother Edward ascended the throne. They fortified Chester in 907 and with the Danes held off the Norwegians when the latter besieged Chester in 909. Later, with the Scots (Irish) and Welsh, she formed an alliance to resist the barbarians from the north. Her husband died about 911 and Ethelfleda lost Middlesex and Oxfordshire to her brother but managed to hold the rest of her territory. In 916 she led an expedition against the Welsh, took Derby in 917 from the Danes and Leicester and York in 918. She was buried in Saint Peter's, Gloucester. Having wielded almost royal authority the title of queen is frequently given her by the chroniclers. Consult 'Saxon Chronicle'; 'Fragments of Irish Annals,' edited by D. O'Conor.

**ETHELRED I**, king of England: d. 871. He was the fourth son of Ethelwulf and succeeded, his brother, Ethelbert, in 866. Assisted by his brother, Alfred the Great (by whom he was succeeded), Ethelred drove the Danes from the centre of Mercia, where they had penetrated, but the Mercians refusing to act with him, he was obliged to trust to the West Saxons alone, his hereditary subjects. Notwithstanding various successes, especially a great victory at Ashdown, the menace of the invaders continually increased.

**ETHELRED II**, king of England: b. 968; d. London, 23 April 1016. He succeeded his brother, Edward the Martyr, in 978, and, for want of sound judgment and sagacity, was surnamed the "UNREADY" (without *rede* or counsel). About 981 the Danes, who had for some time ceased their inroads, renewed them with great fury. In his reign began the practice of buying them off with ever-increasing presents of money. After repeated payments of tribute (see *DANEGELD*) he effected, in 1002, a general massacre of the Danes in England. Such revenge only rendered his enemies more violent; and in 1003 Sweyn and his Danes carried fire and sword through the country. They were again bribed to depart; but, upon a new invasion, Sweyn obliged the nobles to swear allegiance to him as king of England; while Ethelred, in 1013, fled to Normandy with his

family. On the death of Sweyn, in 1013, he was invited by the national council to resume the government. Ethelred, in 1002, married, as his second wife, Emma, sister of the Norman Duke Richard II, by whom he was father of Edward the Confessor. His reign is described by Freeman as the worst and most shameful in English annals.

**ETHELREDA**, Saint, East Anglian princess: b. Exning, Suffolk; d. Ely, 23 June 679. Although twice married she never lived in wedlock with either of her husbands but kept her monastic vow. She finally became abbess of Ely, and the county fair held in the Isle of Ely on her day, after her canonization as Saint Ethelreda or Audrey, gave rise to the expression "tawdry," as indicating something cheap and fine, such as would be offered for sale in a village booth.

**ETHELWULF**, king of England: d. 858. He succeeded his father, Egbert, in 839, and soon after his accession associated his son Athelstan with him, giving him the sovereignty over Essex, Kent and Sussex. In 851 the Danes poured into the country in such numbers that they threatened to subdue it; and though opposed with great vigor by Athelstan, they fixed their winter quarters in England, and next year burned Canterbury and London. After inflicting a great defeat on the Danes at Ockley, he went on a pilgrimage to Rome, and on his return found his son Ethelbald in revolt against him. In order to avoid a civil war, he gave up the western division of the kingdom to his son, retaining Kent for himself. The youngest of his children was Alfred the Great.

**ETHENDUN**, Battle of, the victory which Alfred the Great gained over the Danes (878), and which led to the treaty with Guthrum, the Danish king of East England. The locality where the battle was fought is supposed to be at Edington, in Wiltshire.

**ETHER**, **ETHYL ETHER**, **DIETHYL ETHER**, or **SULPHURIC ETHER**. When the term ether is used without qualification, diethyl ether ( $C_2H_5$ )<sub>2</sub>O, is universally understood to be meant, just as ethyl alcohol is understood, when alcohol is mentioned without qualification. Ether is prepared by distilling a mixture of five parts of 90 per cent alcohol and nine parts of concentrated sulphuric acid, at a temperature of 285° F., alcohol being fed continuously into the retort during the operation. The distillate is treated with lime to remove traces of sulphuric acid, and dried with calcium chloride, and is then redistilled. The substance so obtained is a mobile, colorless, inflammable liquid of agreeable odor, with a specific gravity of about 0.72 at ordinary temperatures. It volatilizes rapidly with the production of great cold. Its vapor mixed with air is highly explosive. It will not mix with water to any great extent, but will mix readily with many organic fluids, and also with liquid carbon dioxide. It dissolves bromine and iodine, sulphur and phosphorus sparingly, guncotton, rubber, most of the resins and fats, and many of the alkaloids. It boils at 95° F., under a pressure of one atmosphere, and at 200° F. below zero it freezes into a crystalline solid, which melts again at about 180° F. below zero. A hydrate of ether is ob-

tained by evaporating aqueous ether on blotting paper. It becomes solid at 26° F.

The inhalation of the vapor of ether produces insensibility and it is used for this purpose in surgical operations. Ether is also used anæsthetically in the form of a spray producing an intense cold with inhibition of pain locally. See **ETHERS**.

**ETHER**, **The**, or **COSMICAL ETHER**, in physics and astronomy, postulated material substance, which is assumed to fill all space, and to penetrate freely among the ultimate particles of which all matter is composed. It is not in any way related to the substance known as "ether" to the chemist, and the identity in name is unfortunate. The physicist has the advantage of priority, however, and cannot be expected to change the name because the chemist subsequently appropriated it for something else. Although it has not been possible to determine the properties of the ether of physics, the admission of its existence seemed a necessity of scientific reasoning. For we know that light is some kind of a periodic disturbance, and we know that it travels through interstellar space with a definite, finite speed. It appears absurd to suppose that a motion of any kind could take place in a void, in which there was nothing to be moved; and hence, as has been said, it appears to be a logical necessity to assume the existence of some kind of a luminiferous (light-bearing) ether throughout space. As soon as we begin to inquire closely into its nature, however, we encounter difficulties that have proved insuperable. Obviously our conclusions in this respect depended to a large extent upon a study of the phenomena of light and, later, of electricity, and of the kind of motion that would be competent to produce those phenomena. Naturally the assumption was first made that the ether, when submitted to stress, conforms to the same laws of elasticity that hold true in ordinary matter. (See **ELASTICITY**). In that case the full mathematical theory of the motion of the ether would involve no less than 21 numerical coefficients, if the ether were anisotropic. And it is as reasonable to believe that, whatever its nature may be, it is the same in all its parts, and that its properties, whatever they may be, are the same in all directions. If these two facts are admitted—that is, if the ether be admitted to be isotropic—then the number of constants involved in the theory reduces to two. These, as is explained in the article **ELASTICITY**, are (1) the modulus of compressibility, and (2) the modulus of rigidity. If the ether were analogous to a liquid or a gas, its modulus of rigidity would be zero. It is found, however, that the equations of motion that are obtained by making the modulus of rigidity zero are not at all competent to explain the actual phenomena of light; for in this case the ether-waves would be merely waves of alternate compression and rarefaction, like those of sound in the air, and there could be no such phenomenon as polarization. It must therefore be admitted that the modulus of rigidity of the ether has a definite, finite value, if the ether itself is to be regarded as analogous to other kinds of matter, so far as its general mechanical deportment is concerned. If it be also admitted that the modulus of compressibility of the ether has a definite, finite value, the conclusion is reached

that the ether can transmit two essentially different kinds of waves, one of which involves distortions of its parts, while the other involves changes in its density. Of these the first would admit of polarization, while the second would not. Moreover, the two kinds of waves would have, in general, different velocities of propagation; and the fact that all ether-disturbances appear to be propagated at the same speed indicates that only one kind exists, and that we must therefore make one of the three following assumptions with regard to the compressibility of the ether: (1) The modulus of compressibility of the ether is infinite; or (2) it is zero; or (3) the circumstances under which the atoms (or their component electrons) impress their motions upon the ether are such that the modulus of compressibility is not involved in any way. The first of these alternatives implies that the ether is absolutely incompressible, and this is the one that has been most favorably regarded by physicists in general. The second implies that the ether yields indefinitely, even to the smallest compressive forces, so that it is essentially unstable. This view has been developed in recent years by Lord Kelvin, but it is hard to regard it as more than a mathematical possibility. The mind cannot be brought to admit that it corresponds to the actual state of affairs in space. The third of the suggested alternatives must also be regarded as improbable, although, for lack of exact knowledge, we can hardly pronounce it impossible. On the whole, therefore, it is plain that if the elastic behavior of the ether is analogous to that of ordinary bodies, we have to admit (tentatively, at least) that so far as elastic properties are concerned, the ether resembles an absolutely incompressible solid.

According to the elastic-solid theory of the ether, light consists of a periodic or wave-like disturbance in a jelly-like medium, the waves traveling in straight lines with a uniform velocity of about 186,000 miles per second, and the direction of oscillation of the ether being at right angles to the direction in which the wave progresses, just as the direction of oscillation of the various points of a rope along which a wave is passing is at right angles to the rope. This view of the case accords very well with most of the observed phenomena, but there are some that do not appear to be reconcilable with it. We assume that the ether penetrates all bodies, and fills up the spaces between their molecules (or electrons); and as the phenomena of refraction show that the velocity of light is less in a transparent solid (say in glass) than it is in a vacuum, it follows that the ether in the glass has either a greater density or a less rigidity than it has in free space. Either of these suppositions will fit this simple case equally well; but there are other phenomena that will not be satisfied so easily, and it has been found to be impossible to make any single set of consistent assumptions which shall reconcile the "elastic-solid" theory of the ether with all the known facts. For example, when we come to investigate certain problems in partial reflection from transparent media, and others relating to diffraction from small particles, we are obliged to conclude that it is the density of the ether that varies, the rigidity remaining practically constant. On the other hand, the phenomena of double refraction require us to

admit that the rigidity of the ether in a doubly refracting body is different in different directions; and hence we conclude that the rigidity of the ether is modified by the presence of molecules of matter—a conclusion at variance with that previously reached by considering the phenomena of diffraction and partial reflection. Other difficulties have been encountered in the application of the elastic-solid theory of the ether to the phenomena of light, and although reference to it is common, because it is definite enough to present a clear image to the mind, and so is helpful in many ways, the general opinion among physicists of the present day is that it is no longer tenable as an accurate description of the real properties of the ether. It has been abandoned in favor of the "electromagnetic" theory of Maxwell, and in abandoning it we also abandon his method of estimating the density and rigidity of the ether.

Faraday was convinced, many years ago, that there is some mechanism by which magnetic and electric forces are enabled to make themselves felt through a space apparently vacuum. "Such an action," he said, "may be a function of the ether; for it is not unlikely that, if there be an ether, it should have other uses than simply the conveyance of radiation." Maxwell, after reading Faraday's writings, became so impressed by the ideas which they advanced that he applied his own ingenious and powerful mind to the problems whose solution Faraday had dimly glimpsed, and succeeded in completely revolutionizing our ideas with regard to light and the ether. His now famous "electro-magnetic theory" is given in his masterly but exceedingly difficult 'Treatise on Electricity and Magnetism' and a popularized account of it may be found in Oliver J. Lodge's 'Modern Views of Electricity.' He agrees with previous writers that light is some sort of a periodic disturbance in some sort of an ether, and that the displacements that occur are indeed perpendicular to the direction in which the light-wave travels; but he teaches us that these displacements are not analogous to those that are produced in an elastic solid when that solid is deformed. He considers that they are of an electrical nature, and that we must learn about them not by observing the behavior of elastic bodies under stress, but by observing the phenomena exhibited by electrified bodies. Maxwell has given us the fundamental equations that must be satisfied when an electrical disturbance is propagated through the ether, and by means of these equations the entire theory of light can be constructed on the new basis. The theory thus constructed agrees well with the facts of observation, and it is free from the objections that beset the old elastic-solid theory. Moreover, it successfully withstood the searching experimental tests devised and executed by Hertz and his followers, whose labors have shown us that electrical radiations are propagated with the same speed as light, and that they can be reflected, refracted, diffracted, polarized, and made to interfere; so that we are now quite ready to admit that light consists in a rapid succession of such radiations. It is not at all essential to Maxwell's theory that we should know precisely what an "electrical displacement" really is, and hence it does not teach us so much about the nature of the ether as we might desire. It does teach that the elastic-solid analogy is probably not

correct, and it strongly suggests that the ether is incompressible, and that there is some kind of an ethereal rotation going on in a magnetic field; but it has not yet been made to furnish a means of estimating the density of the ether, nor of obtaining any of its other constants.

We do not even certainly know whether the ether is continuous, or whether it is molecular in structure. Some writers find it difficult to think of a displacement of any kind, in a space that is entirely filled with matter, especially if the matter is incompressible. Others hold that this objection is without weight.

Faraday's idea that magnetic and electric induction are propagated by the same medium as light proved to be exceedingly fruitful, and it is by no means unlikely that the ether possesses still other functions, which will throw further light upon its nature, when they are understood. The various kinds of radiations that have been discovered in recent years ("cathode rays," "Bequerel rays," "X-rays," and the like) were at first believed by many authorities to consist in ethereal motions different from those constituting light, and it was even thought that some of them might correspond to the waves of ethereal compression that had been so earnestly sought. Some of these radiations, however, are now believed to be nothing but ordinary light of exceedingly short wavelength, and others are believed, at least tentatively, to consist in the actual emission of storms of corpuscles, or "electrons," from the bodies from which they proceed. (See ELECTRON; RADIUM; RADIATION). Gravitative action has also been attributed to ether stresses, and it is not impossible that this is its real nature. No mechanical explanation of gravitation, as an ether-phenomenon, has yet been offered, however, to which serious objections cannot be urged. In Maxwell's theory of gravitation it is assumed that bodies produce a stress in the ether about them, of such a nature that there is a pressure along the lines of gravitative force, combined with an equal tension in all directions at right angles to those lines. "Such a state of stress," says Maxwell, "would no doubt account for the observed effects of gravitation. We have not, however, been able, hitherto, to imagine any physical cause for such a state of stress." He calculates that to produce the actual effects of gravity, as observed at the surface of the earth, the ether would have to be subject to a pressure of 37,000 tons per square inch in a vertical direction, and a tension of the same numerical magnitude in all horizontal directions.

One of the most obvious difficulties in the way of the ether-theory is that the planets, and even the atoms, move through space as though it were absolutely empty. According to modern ideas, however, the atom may be only an aggregate of smaller "electrons," each of which may transpire to be nothing but a state of strain in the ether; and if this proves to be the case, we are certainly not in position at present to say that the ether would oppose in the slightest degree the transmission of such a state of strain through its own substance. The difficulty with the theory of aberration is more formidable. If a shower of rain is falling vertically, the drops will appear to an observer to descend vertically so long as he remains stationary. If he moves forward, however, the drops will strike

him in the face and will therefore appear, to him, to come from some point slightly in advance of the zenith, rather than from the zenith itself. A similar phenomenon is observed in connection with light and is known as aberration. Every star is seen in its true position when the earth is moving directly toward it; but three months later, when the earth is moving at right angles to this direction, the observer's telescope will have to be inclined slightly toward the direction in which the earth is moving, in order that the light from the star may come down through the instrument centrally. The maximum displacement that a star can have, from this cause, is known by observation to be about 20.47 seconds of arc on the heavens. If the ether were motionless, the analogy with the raindrops would be perfect, and the "constant of aberration," whose value has just been given, could be calculated from the known velocity of light, and the known velocity of the earth's orbital motion. It is found, however, that the theory of aberration is exceedingly complicated when the possibility of currents in the ether is admitted, and hence physicists have been much concerned to know whether or not the earth drags the adjacent ether along with it, in its motion around the sun. As long ago as 1859 Fizeau showed, by a justly celebrated experiment, that the ether is apparently dragged along by a current of water flowing through a tube; and Michelson and Morley have since shown, by an even more ingenious experiment, that there is evidence that the ether in the immediate vicinity of the earth participates in the earth's motion to such an extent that any difference that may exist does not amount to the twentieth part of the whole motion. Lodge, on the other hand, found no evidence of any "ether drag" in the space between two rapidly whirled steel plates that were separated by an interval of one inch. (Consult Preston, 'Theory of Light'). The whole subject of the "drag" of the ether is still unsettled; but the observed value of the constant of aberration appears to require that the ether is not disturbed by the motion of the earth through it.

As indicative of confused condition of thought in regard to the ether, even among the most illustrious scientific minds, the following quotations are appended. Sir William Thompson (Lord Kelvin) says: "The luminiferous ether is an elastic solid, for which the nearest analogy I can give you is this jelly which you see." Fitzgerald remarks upon this, "I cannot conclude without protesting strongly against Sir William Thompson's speaking of the ether as like a jelly." Alfred Sang remarks, "Some of the most eminent physicists have adopted the view that the universal medium must be solid. We are asked to conceive our planet moving at the rate of 18 miles per second through it, and, what is still more incredible, that this takes place without any friction." Sir William Ramsey says, "It is almost universally held that all phenomena are 'mechanical,' that is, they are the result of matter in motion, and can be pictured to the mind in a concrete form; that some kind of 'machine' can be imagined which, if it existed, would reproduce the phenomena in question." And, further, "It has not yet been found possible to think out a structure and mode of motion of the ether which will explain or make it possible to realize as a kind of

machine, all the phenomena in which the ether appears to play a part." J. Clerk Maxwell offers the hypothesis that the constitution of ether is made up of elastic centres or vortices in close proximity, but goes on to say, "No theory of the constitution of the ether has yet been invented which will account for such a system of molecular vortices being maintained for an indefinite time."

It has more recently been postulated of the ether (Erwin 1916), that it is structureless, incompressible, motionless, but capable of taking on motion, non-elastic, and capable of indefinite subdivision, and that the subdivided parts can be moved over each other without friction. On the other hand such eminent physicists as Einstein, Ritz and Poincaré deny the necessity for any such suppositional substance as the ether. It is a fact that scientific inquiry is attacking this and similar problems along quite a different line, upon the hypothesis that matter has no existence otherwise than as a mode of motion.

Consult Erwin, M., 'The Universe and the Atom' (New York 1916); Larmor, J., 'Æther and Matter' (Cambridge, Mass. 1900); Preston, S. J., 'Physics of the Ether' (London 1875).

RICHARD FERRIS.

#### ETHEREAL SALTS. See ESTERS.

**ETHEREGE, Sir George**, English dramatist: b. Oxfordshire, about 1635; d. Paris, probably late in 1691. He is said to have spent some time at Cambridge, but this is probably not the case, since we have it on high authority (Dennis) that he was unacquainted with either Latin or Greek. He traveled much abroad and spent some time in Paris, where it is probable that he saw the performance of the early comedies of Molière. Returning to England he studied law for some time. After 1660 he wrote 'The Comical Revenge, or Love in a Tub,' which was produced in 1664 at the Duke's theatre. It was very successful and brought the author the patronage of the court. In 1668 he produced 'She Would if She Could,' a rather frivolous and immoral work, but which attained a great success. For many years Etherage neglected literature but returned in 1676 with 'The Man of Mode, or Sir Fopling Flutter,' a splendid comedy of intrigue. It added to the author's fame and fortune, but his dissolute mode of life soon dissipated the latter. He was knighted about 1680 and soon afterward married a rich widow. Charles II sent him on a mission to The Hague and in 1685 he was Minister at Regensburg. He remained there for three and one-half years, but never liked Germany. Consult the edition of his works by Verity (1888) and Gosse, 'Seventeenth Century Studies' (London 1895); 'Cambridge History of English Literature' (ib. 1907-13).

**ETHERIDGE, Emerson**, American statesman: b. Carrituck County, N. C., 28 Sept. 1819; d. —. When 13 years of age he removed to Tennessee, received a public school education, studied law and was admitted to the bar in 1840. He was a member of the legislature in 1845-47, and a candidate for speaker, and was then sent to Congress as a Whig and re-elected by the "American" party, serving from 1853 to 1857. He was defeated for the next Congress

but was re-elected in 1858 and served again in 1859-61, in which session he was chairman of the Committee on Indian Affairs. He was then elected clerk of the House of Representatives and served from 4 July 1861 to 8 Dec. 1863. On his return to Tennessee he devoted himself to the practice of his profession and the study of philosophy. He served in the Tennessee Senate in 1869-70 and was twice nominated for the governorship of his State, being defeated once and declining the second nomination. He was the last Whig that served in Congress. He published 'Speeches in Congress' (Washington 1857).

**ETHERIDGE, John Wesley**, English non-conformist clergyman: b. near Newport, Isle of Wight, 24 Feb. 1804; d. Camborne, 24 May 1866. He was educated by his father and later acquired a thorough knowledge of Hebrew, Greek, Latin, Syriac, German and French. In 1826 he attempted to enter the ministry and after a period of probation was received in full connection at the conference of 1831. Thereafter he spent two years at Brighton, when he removed to Cornwall. In 1838 his health began to fail and he was pensioned and went to live at Caen and Paris. His health improving, he accepted the pastorate of a Methodist church at Boulogne in 1842. Four years later he returned to his native land and was successively on the circuits of Islington, Bristol, Leeds, Penzance, Penryn, Truro and Saint Austell in Cornwall. Heidelberg conferred on him the degree of Ph.D. He published 'The Apostolic Ministry and the Question of Its Restoration Considered' (1836); 'Misericordia, or Contemplations of the Mercy of God' (1842); 'Horæ Aramææ' (1843); 'The Syrian Churches: Their Early History, Liturgies and Literature' (1846); 'The Apostolical Acts and Epistles from the Peschitto, or Ancient Syriac, to which are Added the Remaining Epistles and Book of Revelation from a later Syriac Text' (1849); 'The Targums of Onkelos and Jonathan ben Uzziel on the Pentateuch, with the Fragments of the Jerusalem Targum' (2 vols., 1863); 'Life of Rev. Adam Clarke' (1858). Consult memoir by T. Smith (London 1871).

**ETHERIDGE, Robert**, English geologist: b. Ross, Hereford, 3 Dec. 1819; d. Chelsea, London, 18 Dec. 1903. He engaged in mercantile pursuits and devoted his spare time to natural history study. He became curator of the museum attached to the Bristol Philosophical Institution, was made assistant paleontologist in 1857 and paleontologist six years later of the Geological Survey. In 1881 he was transferred to the geological department of the British Museum, where he was assistant curator for 10 years. He published 'Catalogue of Fossils in the Museum of Practical Geology,' in collaboration with Huxley (1865); 'Fossils of the British Islands, Stratigraphically and Zoologically Arranged' (Vol. I, 1888).

**ETHERS**, in chemistry, those compounds which may be regarded as derived from water by the replacement of each of the hydrogen atoms by a basic or alcoholic radical. The ether is "simple" if the basic radicals that are so substituted are alike, and it is "mixed" if they are unlike. The formation of a simple ether may be conveniently illustrated by the case of common, or "diethyl" ether, (C<sub>2</sub>H<sub>5</sub>)<sub>2</sub>O.

This may be prepared in various ways, but the sulphuric-acid method will serve best to illustrate the nature of the compound. When alcohol,  $C_2H_5OH$ , is heated to  $285^\circ F$ . with sulphuric acid,  $H_2SO_4$ , one of the hydrogen atoms of the acid, is replaced by the alcohol radical ethyl  $C_2H_5$ , according to the equation  $C_2H_5OH + H_2SO_4 = (C_2H_5)HSO_4 + H_2O$ , the compound  $(C_2H_5)HSO_4$  being known as hydrogen-ethyl-sulphate, or "sulphovinic acid." When the hydrogen-ethyl-sulphate comes in contact with another molecule of the alcohol, it undergoes a second transformation, by which another ethyl radical is taken up, and a molecule of sulphuric acid again set free, as indicated by the equation  $(C_2H_5)HSO_4 + C_2H_5OH = (C_2H_5)_2O + H_2SO_4$ . It will be seen that although a molecule of sulphuric acid is used up in the first part of the process, it is regenerated in the second part, so that on the whole there has been no change in the quantity of acid present. The water produced in the first stage, and the ether,  $(C_2H_5)_2O$ , produced in the second stage, pass off in the state of vapor, and the apparatus is ready for the admission of a new supply of alcohol. The process by which an ether is formed, as here illustrated, is called etherification; and the etherification is said to be "continuous" if it can go on, as in this case, by merely passing a stream of the alcohol into one end of the apparatus, and withdrawing the vapor of ether and water at the other end. Methyl ether, for example, can be formed by the action of sulphuric acid upon methyl alcohol in a manner precisely analogous to that explained above. The equations in this case are  $CH_3OH + H_2SO_4 = H_2O + (CH_3)HSO_4$ ;  $(CH_3)HSO_4 + CH_3OH = H_2SO_4 + (CH_3)_2O$ ; where  $CH_3OH$  is methyl alcohol,  $(CH_3)_2O$  is methyl ether, and  $(CH_3)HSO_4$  is hydrogen-methyl-sulphate.

As an illustration of a mixed ether, the case of methyl-ethyl ether may be cited. If ethyl alcohol be heated with iodine in the presence of phosphorus, a substance known as ethyl iodide is formed. Thus:  $5C_2H_5OH + 5I + P = 5C_2H_5I + H_3PO_4 + H_2O$ . On the right of this equation,  $H_3PO_4$  is phosphoric acid, and  $C_2H_5I$  is ethyl iodide, which is a liquid boiling at  $152^\circ F$ ., readily separable from the phosphoric acid by distillation. Now if ethyl iodide be mixed with potassium ethylate (obtained by dissolving metallic potassium in absolute ethyl alcohol), the following reaction occurs, and ethyl ether is formed:  $C_2H_5I + C_2H_5OK = KI + (C_2H_5)_2O$ . But if the ethyl iodide is mixed with potassium methylate,  $CH_3OK$ , which is obtained by dissolving metallic potassium in absolute methyl alcohol, then the ether that is formed contains the radical methyl,  $CH_3$ , and also the radical ethyl  $C_2H_5$ , and hence is a mixed ether;  $C_2H_5I + CH_3OK = KI + C_2H_5OCH_3$ . The mixed ether,  $C_2H_5OCH_3$ , is known as methyl-ethyl ether. The reactions that have here been given at some length are typical of similar ones that hold true very generally of the alcohols and ethers. In all the more familiar cases the iodide of a given alcohol radical can be prepared by treating the corresponding alcohol with iodine and phosphorus; and a potassium "alcoholate" can be formed by dissolving metallic potassium in the corresponding (anhydrous) alcohol. Then if we wish to prepare a proposed

mixed ether, we have only to treat the iodide of one of its radicals with the potassium compound of the other one, as indicated above. The commoner ethers, both simple and mixed, strongly resemble one another in their general properties. Thus they will not mix with water, nor combine with ammonia nor other alkalies, nor with metallic sodium, nor with dilute acids. The resemblance is also close in other respects. For "compound ethers" see ESTERS.

**ETHICAL DETERMINISM.** See DETERMINISM.

**ETHICAL MOVEMENT AND ETHICAL SOCIETIES IN AMERICA AND ABROAD.** The first Ethical Society was established and the Ethical Movement inaugurated in 1876 in New York by Felix Adler, then a lecturer at Cornell University. In response to a call, several hundred persons met in May at Standard Hall and at the conclusion of Professor Adler's address, outlining the purpose and spirit of the proposed organization, the Society for Ethical Culture of New York was constituted. In this address he appealed to his auditors to unfurl a new flag of peace and conciliation over the bloody battlegrounds where religions had fought in the past; he laid stress upon the urgent need of a higher and sterner morality to cope with the moral perils of the hour, especially noting the growing laxity that accompanied the decline of discredited forms of religious belief; and he placed peculiar emphasis upon the duty of caring for the moral education of the young. The society thus initiated grew rapidly, and soon gave practical effect to his program. Within a few years it had established a free kindergarten for the children of the poor, the first of its kind in New York; and this developed into a workingman's school, based upon the Froebelian pedagogy, which was the first school to introduce manual training and systematic ethical instruction into the curriculum. It also inaugurated a system of trained nurses for the poor, which has since become an adjunct of dispensary out-door relief in the city. Nor were the larger social and political applications of morality to contemporary life neglected: its leader devoting special attention in his platform utterances to the labor problem and specific social reforms, as being at bottom great moral issues. His vigorous exposure of the evils of the tenement houses bore fruit in the creation of the Tenement House Commission of 1884, of which he was appointed a member. He also was among the first advocates of small parks in the congested districts, of public playgrounds and public baths; and, above all, of greater justice and humanity in the relations between labor and capital, employer and employed. The Labor party here found a new type of advocate; and reformers and politicians a platform from which the issues of the hour were brought to the touchstone of ethical first-principles.

Meanwhile, the society filled more and more the place of a church in the lives of its hitherto unchurched members. It did not neglect the problems of the personal life, but aimed to illuminate and inspire its members in their dealings with the problems of the home and the vocation, family relations, marriage, the

training of the young, etc. Its position as a distinctive religious organization became better understood and its religious appeal more forcibly felt, while its practical educational and philanthropic activities continued to multiply. Its schools, testifying to its conviction that moral improvement must begin with the care and education of the young, expanded until kindergarten normal and high school departments were added. These expansions necessitated greatly enlarged quarters; the society therefore erected at Central Park West and 63d Street a thoroughly modernized school building, next to which an appropriately dignified meeting place and society-house were later on added. This thoroughly equipped schoolhouse has enabled the society to fulfil its cherished aim of having a model and experimental school, standing for the highest ideals of non-sectarian education and the most efficient pedagogical method of realizing them. Many significant developments have taken place including unique Arts High School. What distinguishes these from many other similar schools is their democratic organization and spirit; like the public schools, they educate children both of the well-to-do and of the poor, a generous proportion of free pupils being admitted under a system of free scholarships endowed by the society.

To give further effect to its conception of a religious society as a body of workers, bent upon learning by doing and promoting piety by service, the society opens to its members many other fields of education and philanthropic activity. Here the women of the society take a prominent part. Most of the philanthropies are affiliated under a general representative body, known as the Women's Conference. Fortunate in drawing an unusual number of young men to its ranks, the society has a strong Young Men's Union which contributes largely to the support of two neighborhood houses: the Hudson Guild on the West Side, of which Dr. John Lovejoy Elliott, one of Professor Adler's associate lecturers, is the head worker; and the Down-Town Ethical Society, on the lower East Side. The Union also owns and supports a summer home on its farm of 70 acres at Mountainville, N. Y., where a farm school is held, and a summer holiday is given to groups of the boys and girls who belong to the Neighborhood clubs. The larger policies and relations of all the working bodies of the society are considered and shaped by a Council of Fifty, composed of representatives from all of them. One other event in the history of the society that calls for mention is the recent appointment of Professor Adler to the newly created chair of political and social ethics at Columbia University. As the chair was endowed with a view to Professor Adler's tenure of it at the instigation of some members of the well-known Committee of Fifteen appointed by the chamber of commerce to deal with the social evil in New York, of which committee Professor Adler was an active member, this appointment is a remarkable public tribute to the large public place which the founder of the ethical movement has won for himself and for it.

Early in the history of the society, a number of young men, including William M. Salter and Walter L. Sheldon, were at-

tracted to it, and, after a period of apprenticeship in New York, went forth to found societies in Chicago, Philadelphia and Saint Louis, and across the seas to London. To these have been added organizations in Brooklyn, Newark, the Bronx and Wilmington, Del., the heads and lecturers of these being in New York, Dr. Felix Adler, Dr. John Lovejoy Elliott, Dr. David Saulle Muzzey and Mr. Alfred Martin; in Philadelphia, Mr. E. Burns Weston; in Saint Louis, Mr. Percival Chubb; in Chicago, Mr. Horace J. Bridges; in Brooklyn, Dr. Henry Neumann; in Newark Mr. George E. O'Dell. These American societies, while loosely federated in a union, maintain an individuality of their own, and have developed different forms of activity according to local needs and circumstances. Local settlement work was done in Saint Louis as early as 1889, when "Wage Earners' Self Culture Clubs" were established in four sections of the city. They all hold Sunday exercises, which consist for the most part of music, readings and an address. All admit to membership on a simple declaration of devotion to the ethical ends. All attach great importance to the moral and religious education of the young, and maintain well-organized Sunday schools and associations and clubs of young men and young women devoted to the same end and to various kinds of practical work. From the publishing and literary headquarters of the Ethical Union in New York is issued monthly, *The Standard*, the organ of the movement. Among the literary products of the American societies are Professor Adler's 'The Religion of Duty,' 'Moral Instruction of Children' and 'Life and Destiny,' etc. Mr. Salter's 'Ethical Religion'; Mr. Sheldon's 'An Ethical Movement'; 'An Ethical Sunday School'; 'Old Testament Bible Stories as a Basis for Ethical Instruction of the Young,' etc., several volumes by Mr. Martin and others.

That the movement initiated in America expressed no merely local phase of religious development is evident by its still more rapid spread in Europe. American influences led to the establishment in 1886 of the London Ethical Society with which Professors Muirhead, Bosanquet, Bonar and others, upon whom the ethical influence of Thomas Hill Green of Oxford had been profound, were identified; and under its auspices lectures were given at Toynbee Hall and elsewhere by many men at the universities and in public life who felt the importance of the new ethical propaganda, such as Seeley, Caird, Leslie Stephen, etc. About the same time Dr. Stanton Coit went over from New York to assume (*vice* Mr. Moncure D. Conway) the leadership of the congregation at South Place Chapel, then renamed the South Place Ethical Society, which, after a brief pastorate, he resigned to push the ethical cause in other ways.

Under his leadership ethical societies multiplied rapidly in London and in the provinces. A union of ethical societies (14 or more), and a moral instruction league (to introduce systematic non-theological, moral instruction into all schools), since become a separate organization, were established. There has also been a considerable output of literature. Special mention should be made of the valu-



able series of books of ethical instruction by Mr. F. J. Gould.

The new movement was finding, meanwhile, favorable soil on the Continent. A centre of activity was established at Berlin, where Professor Gizycki, Prof. William Foerster, and others identified themselves with the cause. Other societies were in time established in Germany, and in Austria at Vienna, in Italy at Venice and Rome, in Switzerland and Zürich and Lausanne; and in France through the Union pour L'Action Morale (1891) which found spokesmen in M. Emil Desjardins (notably in his stirring brochure 'Le Devoir Present'), and in other well-known writers. In Germany the movement languished until only a small group in Berlin under the courageous leadership of Professor Foerster became the only noteworthy survivor.

The early activity of these European centres led to the establishment of an international organization with a central station at Zürich where in September 1896 an International Congress was held which issued a representative manifesto. It is largely colored by a continental sense of the urgency of applying ethical principles in the domain of social and political affairs. It announced its sympathy with the efforts of the populace to obtain a more human existence; but recognized as an evil hardly less serious than the material need of the poor, the moral need which exists among the wealthy, whose integrity is often deeply imperiled by the discords in which the defects of the present industrial system involve them. It demanded that the social conflict should be carried on within the lines prescribed by morality, in the interest of society as a whole, and with a view to the final establishment of social peace. It declared for universal peace, and against militarism and the national egotism and jealousy which precipitate war. Finally, it urged upon all ethical societies not simply to concern themselves with these practical issues, but to devote their utmost energy to the building up of a new ideal of life in harmony with the demands of modern enlightenment. This first international manifesto is still significant because it expresses the almost universal interest of ethicists in the social question, and their desire to bring theories, policies and measures of reform to the test of ethical principle; it expresses also their interest in promoting peace and an education animated and unified by an ethical purpose. It does not, however, lay the stress which would to-day be laid upon the relation of the movement to modern liberalism, its frank acceptance of the spirit and results of modern science, and its repudiation of the supernatural, miraculous and priestly elements in religion; nor does it voice the deeper religious seriousness and spirituality of the movement. By some of the leaders this latter is very strongly emphasized; and some of the ethical societies are primarily churches for inspiration and guidance in the difficult effort to lead the good life. What effect the Great War will have on the international movement it is impossible to predict. So far it has crippled or handicapped the smaller societies. In England there has been a brave struggle to maintain them. Perhaps after the war their great opportunity will

come. In America they continue to move forward.

While the inception of the ethical movement was due to the insight and prevision of Felix Adler, and its first powerful impact due to his attractive eloquence and personal power, its slow but steady growth is evidence that it met a deep and widespread need. It was fitly born on American soil; for a new ethical religion and ethical church for America had been definitely prophesied and sketched by Emerson in his latter essays on 'Worship' and 'The Sovereignty of Ethics.' He had said: "The progress of religion is steadily to its identity with morals. . . . It accuses us that pure ethics is not now formulated and concentered into a cultus, a fraternity with assemblings and holy days, with song and book, with brick and stone. . . . America shall introduce a pure religion. . . . There will be a new church founded on moral science; at first cold and naked, a babe in a manger again, the algebra and mathematics of ethical law, the church of men to come, without shawms, or psaltery, or sackbut; but it will have heaven and earth for its beams and rafters, science for symbol and illustration; it will fast enough gather beauty, music, picture, poetry." The development of advanced Unitarianism through Channing and Parker had been in this direction. It had two practical outcomes—the Free Religious Association, which still holds annual sessions; and the Ethical Movement. As distinguished from the Free Religious Association, which expressed vaguely the libertarian tendencies of Emerson's thought, the Ethical Movement gave effect to the positive and constructive tendency which found clear utterance in his prophecy. Although this positive spirit was present in the religious society conducted in New York by Octavius B. Frothingham—who was wont to say, after he had retired and it had disbanded, that its legitimate successor was the Society for Ethical Culture—it was not until Felix Adler brought to the new movement at once an ethical outlook and philosophy learned chiefly in the school of Kant, an impassioned Hebraic sense of religion as righteousness of life, and a practical sense of the urgency and ethical import of the great impending moral issues in the social, industrial and political world, that conditions existed for the full birth of the new ethical religion.

The most distinctive feature of this new phase of religious development was that it did not propose to add to the religions of the past, in the way in which these had multiplied, namely, on the basis of differences of speculative belief. Instead, it announced the basic importance and the priority of the ethical factor in religion. It approached religion, not from the credal, but from the practical moral standpoint; and it saw, in a common affirmation of this priority and supremacy of virtue and the good life, a ground of union for people of varying philosophical convictions, or none. Following Emerson, it asserted that character and conduct condition creed and thought; and that it is only by sowing a worthy character that men can reap a vital and meaningful creed. It contended that no certain and lasting basis of union can be found in anything so variable and personal

as one's philosophical view of the world; and that no one should pledge his intellectual future by subscribing to-day to a creed which to-morrow he may outgrow. What a man thinks is the result of what he is — the outcome, therefore, of his action, his experience, his effort and his love, far more than it is the outcome of his deliberate thought and accumulated knowledge. This position differed from that of the Comtian Positivists because theirs assumed a final, definite, and in some respects, very negative philosophy. The new movement allowed for the greatest individual differences in men's philosophical interpretation of life, save in the one tenet that all must acknowledge the sacred obligation imposed by man's moral nature to live the good life and to follow without swerving the dictates of duty according to the best light that is in each.

On the basis of this moral earnestness and this attitude of moral resolve men may safely and hopefully work backward into a philosophy and forward into a faith. Their philosophy and their theory of moral sanction may be what it will, theistic or pantheistic, materialistic or idealistic; it may or may not issue in a faith in immortality, conditional or absolute. This is a personal concern, and the statements on such matters frequently made by the leaders of ethical societies who differ much in their philosophies, are merely expressions of personal conviction, and not made as in any way committing the societies. This is to make a clear distinction between the private and the public factors of religious belief; and to find as the only possible basis for religious union, for those who would jealously guard their intellectual integrity, a moral aim by which any man should be ashamed not to be bound.

The ethical movement has been criticized as lacking in imaginative color and appeal, and therefore unlikely to spread among the masses of the people. Perhaps Emerson was right in emphasizing the austerities of the new religion in its early protestant phases. But at heart it is genial and passionately human. It has nothing sensationally novel to offer; it does not compete with picturesque claimants like Theosophy, Christian Science, Vedantism, etc., and it may be a fact that "plain goodness," "mere morality," "the beauty of holiness," will not yet draw many with their old-new evangel. And yet one finds among its adherents nothing less than a new type of the religious temperament, voicing a new imaginative sense of the hidden mysteries and wonders of the moral personality, the new unrevealed heights and depths of the moral life, the unrealized joyousness of devotion to duty and to service.

PERCIVAL CHUBB,

*Leader of the Ethical Society of Saint Louis.*

**ETHICS** (from Gr. *ἠθικά*, having to do with conduct, from *ἦθος*, character, lengthened form of *ἔθος*, custom, manners; cf. morals, from Latin, *mos mores*, customs), that branch of the theory of conduct which is concerned with the formation and use of judgments of right and wrong, and with intellectual emotional, and executive, or overt, phenomena, which are associated with such judgments, either as antecedents or consequents. As a branch of the theory of conduct, it is generically akin to the sciences of jurisprudence, politics and eco-

nomics; but it is marked off from such sciences in that it considers the common subject matter of human conduct from the standpoint of rightness and wrongness. Such terms as good and evil, the dutiful or obligatory, might be used in the definition as substitutes for the terms "right" and "wrong," but good and evil are somewhat too wide in scope, including, for instance, economic utilities, commodities and satisfactions; while duty is somewhat too narrow an idea, emphasizing the notion of control at the expense of the idea of the good and desirable. "Right" and "wrong" designate exactly those phases of good and evil to which the idea of the obligatory is also applicable. The terms moral philosophy, moral science, and morals have also been used to designate the same subject of inquiry.

In its historical development, ethics has been regarded as a branch of philosophy, as a science, and as an art — often as a composite of two or all of these in varying proportions. As a branch of philosophy, it is the business of ethics to investigate the nature and reality of certain conceptions in connection with fundamental theories of the universe. It is the theory of reality in its moral aspect. The term good is taken to denote or describe a property of ultimate and absolute being. As such, it is usually co-ordinated with two other fundamental properties of reality, the true and the beautiful; and the three philosophic disciplines are defined as ethics, logic and aesthetics. Even when so much emphasis is not thrown upon the place of the good in the general scheme of the universe, ethics may still be regarded as a branch of philosophy, because concerned with the ideal, with what ought to be, or with what is absolutely desirable, as distinct from the actual, the existent, the phenomenal. From this point of view, ethics is regarded as *normative* in character, that is, concerned with establishing and justifying certain ultimate norms, standards and rules of action.

In contrast with such functions, ethics as a science is concerned with collecting, describing, explaining and classifying the facts of experience in which judgments of right and wrong are actually embodied or to which they apply. It is subdivided into social, or sociological, ethics, and individual, or psychological, ethics. (a) The former deals with the habits, practices, ideas, beliefs, expectations, institutions, etc., actually found in history or in contemporary life, in different races, peoples, grades of culture, etc., which are outgrowths of judgments of the moral worth of actions or which operate as causes in developing such judgments. Up to the present, social ethics has been developed mainly in connection, (1) with discussion of the evolution of morality, either by itself or in connection with institutions of law and judicial procedure, or of religious cult and rite; or (2) with problems of contemporary social life, particularly with questions of philanthropy, penology, legislation, regarding divorce, the family and industrial reform — such as child-labor, etc. In both aspects it is closely connected with the science of sociology. It is sometimes called inductive, or in its second aspect, applied ethics. (b) Psychological ethics is concerned with tracing in the individual the origin and growth of the moral consciousness,

that is, of judgments of right and wrong, feelings of obligation, emotions of remorse, shame, of desire for approbation; of the various habits of action which are in accord with the judgment of right, or the virtues; with the possibility and nature, from the standpoint of the psychical structure of the individual, of free, or voluntary, action. It gathers and organizes psychological data bearing upon the nature of intention and motive; desire, effort and choice; judgments of approbation and disapprobation; emotions of sympathy, pity in relation to the impulse of self-preservation and the formation and reformation of habit in its effect upon character, etc. In other words, it treats behavior as an expression of certain psychical elements and groupings, or associations: psychological analysis.

Ethics as an art is concerned with discovering and formulating rules of acting in accordance with which men may attain their end. These rules may be considered as of the nature either of injunctions or commands, which prescribe as well as instruct; or as technical formulæ which indicate to the individual the best way of proceeding toward a desired result, thus not different in kind from rules of painting, or of carpentry. Which view is taken depends usually upon the kind of philosophy with which ethics as an art is associated. Ethics as an art may also be an outgrowth of either a general philosophy of conduct, or of a scientific analysis of it. Thus, from the philosophic point of view, a recent writer, Sorley, in the Dictionary of Philosophy and Psychology (Vol. I, p. 346, 1902), says of ethics: "It has to do not merely with actual conduct, but with right or good conduct, and accordingly with an ideal from which rules may be laid down for actual conduct." It is clear that the philosophical establishment of the ideal is considered to terminate in rules for its attainment. On the other hand, Jeremy Bentham in his 'Principles of Legislation' (1789), having before insisted that ethics is a science whose truths are to be discovered "only by investigations as severe as mathematical ones, and beyond all comparison more intricate and extensive," goes on to define ethics "as the art of directing men's actions to the production of the greatest possible quantity of happiness," and says it is the business of private ethics "to instruct each individual in what manner to govern his own conduct in the details of life." Thus as an art ethics may be grounded upon either a philosophy or a science.

As may readily be inferred from the above account, some of the most serious problems of ethics at present are concerned with defining and delimiting its own scope, basis and aims. From a purely abstract point of view, all three conceptions can exist harmoniously side by side. It is possible theoretically to regard certain topics as assigned to ethics as a branch of philosophy, others to its scientific phase, and others to the practical, or to ethics as an art. But no consensus as to these various possible assignments exists. Usually those who insist that ethics is a branch of philosophy deny that it can be anything else; they deny that any descriptive and explanatory account of *actual*, as distinct from ideal, conduct, deserves the name of ethics. What we have above treated

as really a matter of history, sociology and psychology, not of ethics proper at all. Thus Green, 'Prolegomena to Ethics' (1883), begins by attempting to prove that a natural science of ethics is inherently impossible, because moral conduct by its nature implies an ideal that transcends actual conduct which alone can be made a matter of observation and experiment, and sets up an obligation which in its absoluteness transcends all the sanctions of experience. On the other hand, those who have occupied themselves with the scientific analysis of moral behavior and character, have usually denied the legitimacy of the philosophic aspect. Thus Bentham expressly regards all philosophical inquiries as doomed to result in sterility, in mere dogmatic personal assertions, or, as he calls them, "*ipse dixit*." A more recent writer, Leslie Stephen, 'Science of Ethics' (1882), without absolutely denying the possibility in the remote future of a metaphysics of conduct, says that the metaphysical view is entirely irrelevant to a scientific treatment. Along with this uncertainty as to the defining aim and characteristic methods of ethics, are naturally found a large number of subordinate and secondary controversies and divisions of opinion.

As a matter of fact, however, in every historical period there have been found in ethical theories some connection with general philosophic thought, and with the data of behavior exhibited in experience (or the scientific aspect) and with the further direction and conduct of life—the practical aspect. Historically, ethics has passed through three epochs: (1) the Græco-Roman; (2) the Patristic-Mediæval; (3) the Early Modern; terminating with say the French Revolution, and may now be regarded as having entered upon a fourth stage. In each period, a certain practical interest is uppermost in social life, and this interest serves to concentrate and direct attention toward certain relevant theoretic problems. An adequate account of ethical thought accordingly is possible only in connection with the larger civilization and culture of which it is a part. Brief characterizations of the main problem of each epoch in its wider social tendencies will serve, however, to point out (a) the philosophic, (b) the scientific, (c) the practical centre of ethics in each period.

The Græco-Roman period was characterized by the disintegration of local custom, tradition and institution, civil and religious, coincident with the spread of cosmopolitan learning and the formation of an inclusive political organization taking effect in both legislation and administration—Greek culture and the Roman empire. With the disintegration of the habits and modes of life which had previously defined the sphere of legitimate individual satisfaction, and which supplied the sanctions of the moral life, there was necessarily coincident an inquiry which attempted to establish through reflection adequate substitutes for the waning institutional modes of control. One of the results of modern historical science is the proof of the extent and stringency of the force of custom in early life. It is custom which defines the morally right and obligatory, and it is custom which enforces its own demands. In it are bound together morals, law and religion, and all are bound into the very life of the people, emotional and intellectual,

as well as practical. Where custom rules, moral theory is unnecessary and indeed impossible. In the 6th and 5th centuries before Christ, this régime of custom was irretrievably shaken in the Greek world, and with a twofold result upon morals. Many thought that all sanctions for morality had disappeared, or at least lost validity, and that pure individualism in thought and conduct—tempered at best only by some judicious regard to consequences—was the proper outcome. Others, prevented by what they regarded as the low moral standards of customary morality from coming to its defense, were also shocked by the demoralization attendant upon ethical individualism, and set to work to discover a universal and unassailable basis for a higher type of ideal morality. In this conflict, ethical theory was born.

**The Græco-Roman Period** (6th century B.C. to 5th century A.D.)—The controversy originated in a discussion as to whether morality exists by convention (*νόμος*), by arbitrary enactment (*θέσει*), or in reality, that is (in the terminology of the time), "by nature" (*φύσει*) or in the nature of things. Some of the Sophists taught that morality was a creature of the efforts of the rulers of a community, being a device on their part to keep others in subjection for the better indulgence of their own desires—much as many of the "free-thinkers" of the 18th century (in many respects the modern congeners of the Sophists) taught that religion was an invention of state-craft and priest-craft. Others taught that it was a product of social agreement or institution. Some of the nobler Sophists (like Protagoras, see the Platonic dialogue of the same name) interpreted this as praise of the state of civilization and culture as against the raw, crude state of nature, while others taught that it was merely a conventional means to personal satisfaction, and hence had no binding force when short-cuts to happiness were available. In the meantime the actual moral discipline of the Greek city-state was much relaxed, partly because of the interminable dissensions of party strife, and partly because the religious beliefs which were the foundation of civic life were fast becoming incredible. Socrates (about 470 B.C.—399 B.C.) was apparently the first to undertake a positive and constructive analysis of moral ideas. He made the following contributions: (1) All things have to be considered with reference to their end, which indeed constitutes their real "nature"; the end of each thing is its good. Man must therefore have his own end, or good; this is real and inherent, not conventional nor the product of law. (2) To know is to grasp the essential, real being of a thing—its "nature," or end; "know thyself" is the essence of morality; it means that man must base his activity upon comprehension of the true end of his own being. All evil is really involuntary, based on ignorance or misconception of man's true good. To be ignorant of the good is the one disgrace. If a man does not know it—and Socrates professed that he did not—he can at least devote himself seriously to inquiring, to the effort to learn. If not wise (a sophist) he can at least be a lover of wisdom (a philosopher). And until he attains knowledge, the individual will be loyal to the responsibilities of his own civic life.

The two conceptions of the good as some-

how the fulfilment of man's true nature or reality, and as attainable only under conditions of rational insight are the bases of all later Greek thought. Opinions differed to what man's end is, and as to the character of true knowledge of it. The extreme division was between the Cynic school, the forerunner of the Stoics, founded by Antisthenes (about 444 B.C.—369 B.C.), and the Cyrenaic (the precursor of Epicureanism, founded by Aristippus (about 435 B.C.—360 B.C.)). The former taught that virtue, manifested in temperance or self-control, is the one and only good, pleasure as an end being evil, and that it is known by pure reason. The latter taught that pleasure, known only in feeling (the sensation of a gentle and continuous change) is the good. The wise man of Socrates is he who knows this moderate and enduring pleasure and is not captured by sudden and violent passion. Both schools take a somewhat antagonistic attitude toward the state; the Cynic emphasizing the superiority of the sage to government and authority, well illustrated in the anecdotes of Diogenes and Alexander the Great; the Cyrenaic holding that the pleasures of friendship and social companionship of the congenial are superior to those of participation in public life. These schools thus set two of the fundamental problems of subsequent ethical theory, namely, the nature of the good, and the nature of knowledge of it; and supplied the framework of later schools of thought. Those who hold that pleasure is the good are termed Hedonists (Gr. *ἡδονή*, pleasure); those who held to its residence in the virtuous will Perfectionists, or (with certain qualifications added) Rigorists. Those who hold that it is known through reason are Intuitionists, the other school, Sensationalists or Empiricists.

Plato (q.v.) (about 427 B.C.—347 B.C.) attempted a synthesis of the conceptions of the two schools just referred to, with a constructive program of social, political and educational reform, and with a reinterpretation of earlier philosophic theories of the universe and of knowledge. His most characteristic doctrines are (1) the generalization of the Socratic conception of the good as constituting the true essence or nature of man. Under the influence of philosophic concepts derived from a variety of sources, Plato conceived man as essentially a microcosm; as the universe in miniature. He is composed of a certain arrangement of the elements of reality itself; hence he can be truly known only as the real nature of the universal reality which constitutes him is known; his good is ultimately one with the final cause or good of the universe. Thus Plato goes even farther than Socrates in asserting that morality is by nature—it is by the nature not only of man but of absolute reality itself, which is thus given an ethical or spiritual interpretation. Thus he grounded ethics on general philosophic conceptions and has been the model for all since who have distinctly conceived ethics to be a branch of philosophy. Moreover, since he regards the ultimate good of the universe as one with God and as the animating purpose in the creation of physical nature, he brings ethics into connection with religion, and with man's relations to the world about him. (2) Plato regarded the state in its true or ideal form as the best embodiment or expression of the essential nature of individual man; as indeed more truly man than any

one individual. In its true organization, it reflects or images the constitution of the ultimate good. Thus Plato brings ethics back into connection with politics as the theory of ideal social organization. Practically, he delineates this state in outline (especially in his Republic, and, with greater attention to feasible detail in his Laws), and proposes in view of this ideal a specific reform of the existing order, instead of disregard of it as with Cynic and Cyrenaic. (3) He sets forth a scheme of the good as realizable in human nature, which endeavors to combine the one-sided extremes of mere pleasure and mere virtue. He conceives the good to be the fulfilment of all capacities, faculties or functions of human nature, the fulfilment of each power being accompanied with its own appropriate pleasure, and all being ordered and bound together in a harmonious whole by a law of measure or proportion which assigns to each its proper place; at the head, the pleasure of pure knowledge; at the bottom, the appetites; between, the pleasures of the nobler senses (sight and hearing), and of the higher impulses—ambition, honor, etc. The right functioning of each is virtue; its product is pleasure. The system of pleasures according to virtue is the good. Moreover, he specifies four cardinal virtues which result—wisdom, the knowledge of the good or organized whole; justice, the law of proportion or measure; courage, the assertion of the higher tendencies against the pleasures and pains arising from the contemplation or imagination of the lower; temperance, the law of subordination in accordance with which each lower function is restrained from usurping the place of the higher. Plato's system of ethics remains the standard of ethical theories of the "self-realization" type.

Aristotle (q.v.) (384 B.C.—322 B.C.) gave the philosophic consideration of Plato a more scientific and empirical turn—a contrast, however, which is often exaggerated. He protested against the identification by Plato of human end or good with that of the universe, and consequently attached less importance to knowledge in the form of philosophic insight, and more to practical insight or wisdom. But, in the main assuming the Platonic basis, he carried into detail the analysis of human faculties or functions involved in conduct, giving a careful analysis of desire, pleasure and pain, of the various modes of knowledge, of voluntary action and making a remarkable analysis of the various forms of virtue and vice actually current. In a word he emphasized in detail psychological and social aspects, merely sketched by Plato. On the social side, it had become obvious that the comprehensive scheme of reform entertained by Plato was impossible; and here, also Aristotle is free to undertake a more empirical description and analysis of various forms of government and organization in their moral bases and bearings. When in the 12th and 13th centuries A.D. the works of Aristotle were again made known to the European world, first through translations from the Arabic and then from the Greek, Aristotle's ethics became embodied in the official philosophy of the Roman Catholic Church, especially in the writings of Saint Thomas Aquinas (1225–74), and found literary expression in the Divine Comedy of Dante. His ethical writings have more profoundly affected common speech and thought

than those of any other writer, and to a large extent have become a part of the moral common-sense of civilized humanity.

The details of later ethical philosophy in Greece and Rome form an interesting part of the history of ethics, but, with one exception, supply no new idea of sufficient importance to need mention here. The exception is the Stoic conception of virtue as "living in accordance with nature," and the conception of the "law with nature" which grew out of this. This idea, under the form of *jus naturale*, was taken up into Roman jurisprudence, and became the ideal of a common moral law which underlies all differences of positive municipal law, and which, accordingly, forms an ethical standard by which positive law can be tried, and its diversities reduced to a common denominator. It reappeared in the Middle Ages in the form of the natural law (as distinct from revealed or supernatural law), written on the "fleshy tablets of the heart," and was thus indirectly influential in forming the still current notion of *conscience* as a moral legislative force. It came out in continental ethical thought of the 17th and 18th centuries in the conception of moral law as something analogous to a system of mathematical axioms, definitions and demonstrations, discoverable by reason, and forming the framework of both individual and political ethics.

**Patristic Mediæval Period** (5th to 15th centuries A.D.)—The second period of ethical history is characterized by the subordination of ethics, as a branch of philosophy, to theology. The distinctive features contributed in this period to subsequent ethics are the emphasis laid upon ideas of law, authority, obligation or duty, and merit or demerit, namely, the good as religious salvation involving a knowledge and love of God as supreme perfection, possible only in the next world; and evil as sin, guilt also needing supernatural expiation. Because of the emphasis upon law and authority, moral ideas are largely assimilated to forensic and juridical conceptions. Most significant, however, for ethical theory is the transfer of theoretical interest from the conception of the good, the central idea of ancient ethics, to that of obligation. Not the natural end of man, but the duty of absolute submission of will to transcendent moral authority was the keynote. And even when ethics was freed from subservience to theology, it still remained easier for the modern mind to conceive of morality in terms of the nature and authority of duty than as the process of realizing the good. On the more concrete, empirical side, the great contribution of mediæval theory was in depicting the moral drama, the struggle of good and evil, as it goes on in the individual soul. The fact that this was fraught with significance for an endless future life made it a subject of anxious and minute attention; and here, too, even when the moral region was later marked off more or less definitely from the religious, modern thought owes its consciousness of the subtle perplexities, temptations and shades of moral effort and issue to mediæval rather than to ancient ethics.

**Early Modern Period** (The Reformation to the French Revolution).—The complexity and variety of moral theory and inquiry since the 15th century, as well as its relative nearness, make it difficult to secure the perspective necessary to its proper characterization. It is all

more or less connected, however, with the struggle toward greater individual freedom, and with the problem of maintaining a stable associated and institutional life, on the basis of recognition of individuality—the democratic movement. In its earliest period, modern ethics was largely characterized by reaction against scholasticism; it was an effort to secure a basis for ethics free from subordination to theology and to mediæval philosophy, and the schoolmen's versions of Aristotle. Moreover so much of energy was expended in the practical effort to get freedom of thought, of political action, of religious creed, of commercial life, that moral theory turned largely upon detailed questions arising out of the practical struggle. This accounts to a considerable extent for the scattered, fragmentary condition of modern ethics as compared with the systematic character of either Greek or mediæval thought. Moreover, the very gaining of intellectual freedom of inquiry opened up countless fields of interest. Ethical problems sprang into existence at every turn; every new movement in industry, in politics, national and international, and in art, brought with it a new ethical problem. Social life was itself undergoing such rapid change, and in such tentative, uncertain ways, that each of these problems had to be attacked independently. The result is a critical controversial and individualistic, rather than a constructive and systematized ethics—with the advantage, however, of remarkable richness in detail.

Continental ethics followed the prevailing philosophic method of rationalism; the attempt to build up a theory of conduct, individual and social, on the basis of pure reason, independent of revelation of ecclesiastic authority, or positive institutions. While the method was *a priori* in name, as matter of fact it drew largely upon the inheritance of generalized Roman law, attempting to harmonize and purify it in accordance with ideals of unity and comprehensiveness which were supposed to represent the demands of reason. Grotius (1583–1645) was the founder of this movement, and, in his *De Jure Belli et Pacis*, used the idea of law which is founded upon man's rational nature, which in turn is inherently social, to place international relations of comity, commerce and war upon a more humane and enlightened basis. His German successors, Puffendorf (1632–94), Leibnitz (1646–1716), Thomasius (1655–1728), Wolff (1679–1754), carried on with greater critical acumen and more adequate philosophic instruments, the same work, and finally developed a complete system of rights and duties (called *Naturrecht* after *Jus Naturale*) applicable to all spheres of private, domestic, civil, political and international life—a *code* of morals, positive in effect, but supposed all to be drawn deductively from rational first principles. Upon the whole, the influence of German ethical rationalism was conservative; the result in fundamentals was the justification of the existing social order, purged of inconsistencies and reformed of abuses in detail. French rationalism took a different turn. It attempted a synthesis of the more basal notions of the newly arisen physical science with psychological ideas borrowed from Locke and his English successors. It was rationalistic not so much in attempting to deduce an ethical system from the conceptions of reason, as in subjecting the existing order of belief and insti-

tutions to unsparing criticism as anti-scientific. In its extreme forms it seemed to demand an abrogation of existing institutions, the erection of the same *tabula rasa* in social matters, that Descartes had postulated in intellectual, and a creation *de novo*, by sheer voluntary action, of a new social order, aiming at universal happiness. Reason gives an ideal of society in which all men shall be free and equal, and in which economic want and misery shall be abolished, and a widely diffused intelligence and wealth shall be instituted. Pessimistic to the extreme as regards the existing order, it was equally optimistic as to the possibilities of social organization, culminating in the conception of the infinitely progressive perfectibility of human nature; thus Helvetius, 1715–71 (*De l'esprit*, 1758; *De l'Homme* published 1773); Diderot (1713–84); Condillac (1715–80); D'Holbach (1723–89), especially '*Système Social*' (1773); Condorcet (1743–94). While German ethics had emphasized the conception of natural law which is social in nature, French thought culminated in a deification of natural rights which are individual in their import and location. Certain characteristic features of not only the French Revolution but of the thought of American publicists in the latter half of the 18th century are directly traceable to this influence.

English ethical theory received its impetus from Hobbes (1588–1679). He begins with an analysis of the make-up of the individual, and resolves the latter into a bundle of egotistic impulses, all aiming at unrestricted satisfaction. He denies the existence of any inherent social tendency, or of anything "rational" in the individual save as deliberation may be involved in the individual's efforts after satisfaction. The social counterpart of this unlimited individualism is chaos, anarchy, conflict—the war of all against all. Hence the individual's quest for happiness is self-contradictory. It is possible of fruition only within the state of absolute power which prescribes to each individual the proper sphere of the exercise of his powers. The state is thus the author and sanction of all moral distinctions and obligations. The authority of this state with respect to individuals is absolute; since the source of moral law, it cannot be subject to anything beyond itself. There are thus three strains in Hobbes' teaching. The psychological, which teaches pure egotism and hedonism; the ethical, which makes the state the source of moral values and relations; the political, which makes its authority unlimited. Each strain evoked profound and instant reaction. John Locke (1632–1704) taught that the individual has a natural right to a life of personal security, possession of property and social activity, subject only to limits of the similar rights of others, and that the state comes into existence to protect and secure these rights by settling cases of dispute or aggression, and hence is null and void when it goes beyond this province and encroaches upon individual rights. A succession of writers, notably Shaftesbury (1671–1713); Hutcheson (1694–1747); Butler (1692–1752); Adam Smith (1723–90), undertook a re-analysis of human nature, and endeavored to justify the presence of disinterested benevolent impulses, of tendencies to regard the welfare of others. Cudworth (1617–88); More (1614–87); Cumberland (1632–

1718); Clarke (1675-1729); Price (1723-91) took up the question of the origin of moral distinctions, and tried to show that they were based not in the state but in immutable laws of reason, or upon a science as abstract and certain as mathematics; or else were made known in intuition, etc. But during these inquiries, new problems came to light, and led to a rearrangement of forces. These problems were (1) the relation of happiness—the expression of the self-seeking tendencies of man—to virtue, the expression of his benevolent tendencies; (2) the nature of the test or standard of right and wrong; (3) the nature of moral knowledge. The first problem led in Butler to the attempt to introduce "conscience" as a third and balancing authoritative factor in human nature; and in Smith and Hume (1711-76) to a peculiarly rich and significant theory of sympathy as a central principle through which distinctively moral sentiments are generated and whose exercise is intimately bound up with individual happiness. The second and third problems taken together lead to the conflict of utilitarianism and intuitionism, the former holding that conduciveness to the maximum of possible happiness is the standard of right, the basis of obligation, and the source of all moral rules; this conduciveness to be determined by actual experience; the latter holding that there are moral values, which are inherently and absolutely such, without reference to consequences. Each school has a theological and a non-theological variety. Among theological utilitarians are prominent: Gay (1686-1761), and Paley (1743-1805); among the non-theological Jeremy Bentham (1748-1842) outranks all the others. Without adding much that is fundamentally new to the theoretical analysis, he makes an analysis of happiness in connection with a discussion of the various impulses (or motives as he termed them) of human nature the basis of a thorough-going scheme of judicial and penal reform. Through him utilitarianism became the most potent instrument of the first half of the 19th century of social reform; conduciveness to general and equally distributed happiness being the test by which all customs, traditions and institutions were tried—and by which most of them in their existent forms were condemned.

**Recent Modern.** (From the French Revolution.)—The last 20 years of the 18th century signalize a turning point in the history of thought. Bentham's and Kant's chief works are dated in this period. The French Revolution, carrying into effect the naturalistic rationalism and its optimistic faith in the possibilities of the individual, compelled a reconsideration of the intellectual premises from which it set forth. The problem of 19th century ethics was to get back from the individual to the social whole which includes him and within which he functions; but to do this in a way which should take due account of the deepened significance given to individual initiative and freedom—without, that is, a return to pure institutionalism, or to arbitrary external authority. The following schools or main tendencies are easily distinguishable:

(a) *English Liberalism.*—In Bentham, utilitarianism, as we have seen, became a program of social reform. The attempt to stretch an individualistic hedonism which taught that the

end of desire is always the agent's own pleasure into a theory which taught that the individual should always judge his motives and acts from the standpoint of their bearing upon the happiness of all beings, brought out all the weaknesses of the theory. James Mill (q.v.) (1773-1836) strove valiantly to overcome these weaknesses by a systematic use of the principle of association, in virtue of which individual states become indissolubly connected, through punishment or commerce, with the welfare of others—the theory of "enlightened selfishness," for which Hartley (1705-57) had previously provided the psychological machinery. His son, John Stuart Mill (1806-73) while extending the same idea, introduced into utilitarianism two innovations, which were seized upon by his intuitional opponents as virtual abandonments of the entire hedonistic position. These were that quality of pleasure is more important than quantity and that the individual is naturally social and so instinctively judges his own welfare from the standpoint of society, instead of vice versa. J. S. Mill also severely criticised the other utilitarians for their neglect of the ideal elements in education, and for neglect of the culture element in historical development. Without abandoning the individualistic basis he was much influenced by schools (b) and (c) below. From (b) came the influence of Coleridge (1772-1834); Maurice (1805-72), and Sterling (1806-43). Bain (1818-1903) belongs to the same empirical and utilitarian school. Sidgwick (1838-1900) in his 'Methods of Ethics' attempted a fusion of the utilitarian standard with an intuitional basis and method.

(b) German rationalism culminated in Kant (1724-1804), who reduced the function of moral reason in man to a single principle; the consciousness of the moral law as the sole and sufficing principle of action. Since the claims of this principle are opposed by those of self-love—the desire for personal happiness—the presence of moral reason in us takes the form of a "categorical imperative," or the demand that duty alone, without any influence from inclination, desire or affection, be the motive of conduct. Upon the consciousness of duty are built the ideas of freedom, God and immortality—that is, by moral action is opened to us a sphere of reasonable faith in transcendental realities which are shut to scientific and philosophic cognition. Kant brought rationalism to a turn much as Bentham had affected empiricism. Subsequent German thought attempted to overcome the formalism of Kant's bare reason, making itself known only in a consciousness of obligation. Hegel (1770-1831) attempted a synthesis of the Kantian idealism with the ideas of Schiller, of Spinoza (especially through the medium of Goethe), and of the rising historical school founded by Savigny. He endeavored to show that the social order is itself an objective embodiment of will and reason, and that the regions of civil law, of family life, social and commercial intercourse and above all the state, constitute an ethical world (as real as the physical) from which the individual must take his cue. He anticipated in many particulars from the standpoint of a different method and terminology, doctrines of recent anthropology and social psychology. German moral influence has been felt in English thought chiefly through Coleridge, Carlyle (who was mainly affected by

Kant's successor, Fichte, 1762-1814), and more recently, T. H. Green (1836-82). The New England Transcendentalists were also affected by this school of thought, Ralph Waldo Emerson (q.v.) (1803-82) giving a highly original version of it, blending it with factors of his own personality and with ideas drawn from Puritanism.

(c) In France, the reaction from the individualism of the Revolution was most marked. At the head of the reaction stands Comte (1798-1857), who attempted to build up a theory of ethics upon an organized social basis, similar in many respects to that of Hegel, but relying upon a systematization of sciences rather than upon philosophy, for method, his system accordingly being termed positivism. Comte sought to show how such an ethical-social science could replace metaphysics and theology, the latter in the form of a religion of humanity. He influenced G. H. Lewes and the latter's wife, George Eliot, and also John Stuart Mill.

(d) In the latter half of the 19th century the theory of evolution has been dominant in ethical as well as in other forms of philosophic and scientific thought. Herbert Spencer's application is the best known to English readers. It is, however, generally recognized that his fundamental ethical conceptions were worked out before he became an evolutionist, and that the attachments between his ethics and the theory of evolution are of a somewhat external character. Indeed, it is now clear that the further development of the science of ethics waits upon the more thorough clearing up of the evolutionary ideas themselves, and upon more complete application to biology, psychology and sociology (including anthropology and certain phases of the history of man) in order to supply the auxiliary sciences necessary for ethical science. Through the conception of evolution it is probable that ethics, will be emancipated from the survival of the idea that it is an art whose business is to lay down rules. The practical aspect of the theory of ethics will necessarily remain (since it is theory of practice or conduct), but it will take the form of providing *methods* for analyzing and resolving concrete individual and social situations, rather than of furnishing injunctions and precepts. The coincidence of the evolutionary tendency with the growth of democracy will relieve ethics in its philosophic aspects from its dependence upon fixed values, ideals, standards and laws, and constitute ethics more and more a working method for the self-regulation of the individual and of society.

Every period of ethical theory has been associated, as we have seen, with some corresponding epoch of human development, having its own characteristic problem. Upon the whole, however, ethics has not as yet adequately outgrown the conditions of its origin, and, the supposed necessity they imposed of finding something as fixed and unchanging as custom. Consequently, philosophic inquiry has been devoted to finding *the good*, *the law of duty* etc.; that is, something unchanging, all inclusive. Even the empirical school, in its emphasis upon pleasure, has tried to find something free from conditions of development, something fixed in the sense of being everywhere and at all times the same single unchanging standard and end. Even Spencer distinguishes present ethical codes

as merely relative, and anticipates a period in which evolution will reach its goal—a period in which an unchanging set of rules shall be uniformly binding. But as ethical writers become more habituated to evolutionary ideas, they will cease setting up ideals of a Utopian millennium, with only one end and law; and will devote themselves to studying the conditions and effects of the changing situations in which men actually live.

Consult the works of the authors already mentioned and also Clifford, W. K., 'The Scientific Basis of Morals' (New York 1884); Croce, B., 'Philosophy of the Practical' (London 1913); Dewey and Tufts, 'Ethics' (New York 1908); Mackenzie, J. S., 'Manual of Ethics' (New York 1901); Mezes, S. E., 'Ethics' (London 1901); Palmer, G. H., 'The Field of Ethics' (Boston 1901); Paulsen, F., 'System of Ethics' (New York 1899); Royce, J., 'Philosophy of Loyalty' (New York 1908); Sorly, R., 'Recent Tendencies in Ethics' (Edinburgh 1904); Stephen, Sir Leslie, 'The Science of Ethics' (2d ed., New York 1907); Thilly, Frank, 'Introduction to the Study of Ethics' (New York 1900); Wundt, W. M., 'Ethics' (London 1897-1901).

JOHN DEWEY,

*Professor of Philosophy, Columbia University.*

**ETHIOPIA** (Gr. αἴθω, to burn, and ὄψ, countenance), the biblical CUSH, in ancient geography, the name originally given by the Greeks to the southern parts of the known world. It is divided in the poems of Homer into eastern and western Ethiopia, and this distinction is repeated by Herodotus, and by the later Greek and Roman geographers. Homer gives the southern limit of Ethiopia as the northern boundary of the Southern Sea. Some ancient writers give the boundaries of the three Ethiopian kingdoms, Meroë, Aksum and Napata. Eastern Ethiopia appears to have included southern India, whose inhabitants were called Ethiopians from their color. There were also other Asiatic Ethiopians, an equestrian race, of a darker color than their neighbors, who wore crests made of the hides and manes of horses, and are supposed to have been a Mongolian tribe which had wandered into the steppes of Koordistan. The name Ethiopia was more usually and definitely applied to the country south of Libya and Egypt, between the Red Sea on the east and the desert of Sahara on the west, and embracing the modern regions of Nubia, Sennaar, Kordofan and Abyssinia. In a still narrower sense, the designation was restricted to the province or kingdom of Meroë, which was also called the civilized Ethiopia. African Ethiopia, which is called in the Bible the land of Cush, embraced, according to Pliny, 45 distinct kingdoms; yet as neither the Greeks nor Romans ever penetrated beyond Napata, in lat. 19° N., we are indebted for most accounts of it to Greek imagination. Meroë, between the Nile and the Astaboras, formed the most powerful kingdom, and had a theocratic constitution. The other principal divisions were the Blemmyes, whose aspect was hideous; the Troglodytæ, who lived in caverns; the Macrobbi, or long-lived men; the Ichthyophagi, or fish eaters; and the Creophagi, Chelonophagi, Elephantophagi, Struthophagi, and Ophiophagi, respectively the eaters of flesh, tortoises, ele-



phants, ostriches and serpents. Fable placed also in this region the race of pygmies. Some parts of Ethiopia were named from their productions; as the land of cinnamon, and of myrrh, and the Jews and Phœnicians went thither to obtain aromatics and ivory. The Ethiopian kings seem to have been chosen from among the priests, and the order of succession gave the crown to the nephew of the king, the son of his sister; and in default of an heir, an election was made. The people practised circumcision, and embalmed their dead in a manner similar to that of the Egyptians. They were of an intrepid, impetuous and violent character, and yet are represented as loving and practising justice. Homer makes Jupiter visit them, and sit at their feasts. There were many Ethiopian queens named Candace, one of whom became subject to the Emperor Augustus. Under the Romans the population of Ethiopia became almost wholly Arabian, and so continued after the introduction of Christianity in the 4th century. When the followers of Mohammed overran the entire region some centuries later, the Arabic element gained complete predominance in it. During the Middle Ages the Christians and clergy of Abyssinia were designated as the Ethiopian Church. See *MEROË*.

**Language and Literature.**—Of the different dialects spoken in modern Abyssinia, the Amharic and the Tigré are the most remarkable. The former of these shows little affinity with the ancient language of the country, the Geéz, or the Ethiopic properly so called, which since the beginning of the 14th century, when a dynastic change made the Amharic the language of the court, has ceased to be the vernacular, and is used only by people of education and learning, in religious and civil documents. This ancient language, which has its name from the inhabitants calling it *lesana geez*, that is, language of science, as it is also called language of books, is of Semitic origin, resembling in roots, structure and grammatical forms, the ancient South Arabian dialect of the Himyarites, which since Mohammed has disappeared from the peninsula. This favors the hypothesis of some historians, who suppose the Ethiopians to have been a colony from Arabia. The alphabet also of the Geéz greatly resembles that of the Himyarites, as found in their remaining inscriptions. It consists of 26 consonants and 7 vowels, which are small marks inseparably connected with the former, thus forming a peculiar syllabic mode of writing, analogous to the Devanagari and some other Indian alphabets. Few of these letters show a resemblance to the Phœnician alphabet, while 24 of them may be traced in the Arabic. There are no diacritical marks; the single words are separated by two dots; the accent is difficult; the mode of writing is from left to right, the reverse having been the practice before the introduction of Christianity into Abyssinia. In roots, and forms of expression and construction, the Geéz is poorer than the Arabic. According to Gesenius, one-third of all the roots can be traced distinctly in the Arabic, and many other words may be presumed to be of the same origin, while the roots of others can be found in the Hebrew, Syriac, or Chaldaic, some being native African, a few of Greek, scarcely any of Coptic derivation.

The Geéz has 10 conjugations, 8 of which answer to those of the Arabic, the 5th and the 6th being peculiar. A double infinitive is used substantively, this mood having both an absolute and constructive form. There is no participle. The dual is unknown both in verbs and nouns; the difference of masculine and feminine is observed throughout in the second and third persons. The relation of the genitive is expressed by an inflection, causing some changes in the terminations, or through the relative pronoun; the dative by prepositions; the comparative and superlative degrees by particles. The plural is formed by affixed syllables, *ân* in masculine, *ât* in feminine nouns, on the principle common to the Hebrew, Arabic and Aramaic, or by changes in the radical letters, after the manner of the so-called broken plural in Arabic. In the formation of nouns the Geéz most resembles the Hebrew, but it has superfluous final vowels, modified in certain cases, in which it is analogous to the Arabic in its nunnation. Besides a few fragments in inscriptions, there are no remnants of the ancient Ethiopian literature of a period preceding the introduction of Christianity under Constantine the Great, but of works composed since that time about 200 are known to European scholars. The Old Testament, translated from the Septuagint by unknown Christian writers in the 4th century, is extant in manuscripts in Europe, but only a part of it has been printed. The Psalms were published in Ethiopic and Latin by Ludolf (Frankfort 1701), and in Ethiopic alone (London 1815). The version of the New Testament appeared at Rome in 1548, and in the London polyglot Bible. Of versions of apocryphal books, in which the Ethiopic is particularly rich, several have been published, as the 'Book of Enoch,' translated by Richard Laurence into English (2d edition, London 1833), and by Hoffmann into German (Jena 1838), in *Vatis*, translated by Laurence into Latin, and published in both languages (Oxford 1819). Geéz in 1840 (London), and *Ascensio Isaiaë*. The 'Didascalia, or Apostolical Constitution of the Abyssinian Church,' was published in Ethiopic and English by Platt (London 1834). The *Synaxar* contains lives of saints, martyrologies and the hymns of the Ethiopian Church, in rude rhythmical form, every three or five lines often ending in the same consonant, which forms a kind of rhyme. The profane literature of the Ethiopian language is comparatively poor, consisting chiefly of chronicles, which appear to be of considerable interest, but have not yet been generally accessible. Of these the most remarkable are the 'Keber za Nageste,' containing the traditional and legendary history of the once mighty kingdom of Aksum, a copy of which was brought to Europe by Bruce, and a translation of it appended to his travels; and the 'Tarek Nagushti,' or chronicle of kings. In Europe the Ethiopian language was almost unknown until the time of Job Ludolf, who, being assisted by an excellent native scholar, Abbas Gregorius, made himself master of it, and published an admirable dictionary and grammar (2d improved and enlarged edition, Frankfort 1702). Manuscripts written in the Ethiopian language are in possession of Abyssinian monks and in libraries in Europe. Their knowledge of music may be inferred from their musical notation

which has been published. After a long interval the interest in this language and literature has been revived by the works of Platt, Laurence, Gesenius, Hupfeld, Hoffmann, Rödiger, Ewald and others, as well as by the contributions of Isenberg, Blumberg, and D'Abbadie.

**Bibliography.**—Breasted, 'History of Egypt' (New York 1909); Budge, 'The Egyptian Sudan' (London 1907); D'Almeida, 'Historia de Ethiopia alta' (Coimbra 1660); Bosset, 'Études sur l'histoire d'Ethiophe' (in *Journal Asiatique*, Paris 1881); Bent, 'Sacred City of the Ethiopians' (London 1893); Bruce, 'Travels in Abyssinia' (Edinburgh 1773); Hoskins, 'Travels in Ethiopia' (London 1835); Dillmann, 'Grammatik der Äthiopischen Sprache' (Leipzig 1859; 2d ed. by Bezold, 1899); Prætorius, 'Die amharische Sprache' (1871); id. 'Grammatik der tigrina Sprache' (1871); Schrieber, 'Manuel de la langue tigräi' (Vienna 1887); Goldschmidt, 'Bibliotheca Äthiopica' (Leipzig 1892); Fumagalli, 'Bibliografia Etiopica' (Milano 1893); Littmann, 'Die deutsche Aksum-Expedition' (Berlin 1913); Beccari 'Documenti inediti per la storia d'Etiochia' (Rome 1903).

**ETHIOPIAN CHURCH.** See **ABYSSINIAN CHURCH.**

**ETHIOPIAN PEPPER.** See **GUINEA PEPPER.**

**ETHIOPIAN REGION.** See **ZOOGEOGRAPHY.**

**ETHIOPIANISM,** a movement among the native races of South Africa, having for object negro domination in Africa, thus contemplating the ousting of the whites. It has in the past masqueraded as a sort of religious teaching and took its start in the early 90's of the last century when two black ministers receded from the Wesleyan Church and founded the Church of Ethiopia for blacks exclusively. One of these ministers, Dwane, came to America and had his church recognized by the African Methodist Episcopal Church. Later he sought a union with the Anglican Church at Cape Town and was partially successful through the temporizing and weak-kneed policy of the Anglican archbishop. Various troubles, religious and political, have been traced to the movement; of the latter we may cite the Herero uprising of 1904, and the Zulu insurrection two years later. Little has been heard of the movement within the last decade.

**ETHIOPIC.** See **ETHIOPIA, Language and Literature; ETHIOPIC WRITING.**

**ETHIOPIC WRITING.** See **ETHIOPIA.**

**ETHIOPS MINERAL,** a name formerly given by chemists to the black sulphide of mercury, prepared by rubbing mercury and sulphur together, either hot or cold. *Æthiops martis*, or ethiops of iron, was the black oxide got by exposing iron-filings and water to the air. Vegetable ethiops is the plant bladderwrack, heated until it becomes black, a remedy for scrofula.

**ETHMOID BONE,** The (so called from *ethmos*, "a sieve"), is one of the eight bones which collectively form the cranial box. It is of a somewhat cubical form, and enters into the formation of the cranium, the orbits, and

the nasal fossæ. Its upper surface is perforated by a number of small openings (whence its name). See **Nose.**

**ETHNIC PSYCHOLOGY.** See **PSYCHOLOGY, ETHNIC.**

**ETHNOGRAPHY,** a branch of ethnology, the vast science which treats of mankind as a whole, their origin and their development in language, art, religion and political ideas, from barbarism into civilization. The German scientists class ethnology as a science standing midway between natural history and philosophy. As natural history, in the ordinary sense of the term, is a classification and description of the lower animals, ethnology may fairly be considered as a classification of the various families of the human race, based on the observation of their physical characters, and geographical distribution. From the earliest records and monuments of mankind we find traces of various types of humanity. The statues and paintings of ancient Egypt represent several racial types including the negro, the Berber and the Asiatic. In the first book of Moses, mankind are divided according to their descent from one of the three sons of Noah, Shem's progeny occupying Western Asia, while to the posterity of Ham and Japhet fell North Africa and southern Europe, respectively. Some recognition of the superficial physical differences observable in variously distributed races may also be found in Greek and Roman writers. In the Middle Ages little progress was made in ethnography. The discovery of America, with its revelation of new human types, seems to have given the first genuine stimulus to this study, and the word ethnography was first used in a book published at Nuremberg in 1791, and entitled 'An Ethnographical Picture Gallery.' In his great work, 'Systema Naturæ,' Linnæus classes mankind (*Homo sapiens*) together with the apes under the order of *Primates*, and divided them into four groups, as American, European, Asiatic and African. Buffon in his 'Variétés dans l'espèce humaine' distinguishes the races according to their geographical distribution, though he makes some reference to physical variations. Blumenbach was the first to classify the races of men according to the shape of their skull. The Caucasian, whose skull was symmetrical, he set as the normal type, midway between the Mongolian with the square skull, and the negro with his prognathous skull, while the American was ranged between the Mongolian and the Caucasian, and the Malayan between the Caucasian and the negro. In each of these types he distinguished and recognized as important the character of the hair, the setting of the eyes, and the form of the mouth.

The modern science of ethnography dates from the year 1829 when Milne-Edwards wrote to Thierry, with the result that the Société Ethnologique was founded. The founding of an ethnographic museum was suggested by Jomard in 1843, and built some years later in Paris. Since that time the study has been thoroughly systematized all over the world. While of all ethnographical classifications the most obvious is the enumeration of the white, yellow, red and black-skinned races, as together making up mankind, this is clearly insufficient,

as it would be likely to confound widely different types. Many attempts at a more scientific classification have been made. Oscar Pechsel recognized seven races of men: (1) the Australian; (2) the Papuan, including the Melanesian, the Negrito, etc.; (3) the Mongolian, including the Polynesian, the Malay, the Eskimo, and the American Indian; (4) the Dravidian (southern India and Ceylon); (5) the Hottentot and Bushman; (6) the negro; (7) the Mediterranean races, or Caucasian, which include the Hamitic, Semitic, and Indo-European.

It will be seen that these divisions are based upon other considerations than those of physical character, for it is merely because of their geographical proximity that the Hamitic, which includes the inhabitants of North Africa, can be placed in one category with the Caucasian. Among the most recent systems of ethnographical classification is that of Haeckel who has divided the human family into races in accordance with the variations of a single physical character, that namely of the hair. According to his authority there are two main species and four sub-species of hair found among mankind, who may be broadly separated into the woolly-haired (*Ulotriches*), and the straight-haired (*Lissotriches*). The woolly-haired consist (1) of the crested-haired (*Lophocomi*) subdivision, represented by the Hottentot, and the Papuan; and (2) of the fleecy-haired (*Eriocomi*) which includes the negro and the Kaffir. The straight-haired are subdivided into the streaming-haired, and the curly-haired. To the former belong the Australian, the Arctic dwellers, the American Indian, Malay, and Mongolian; to the latter the Dravidian, the Mediterranean races and the Nubian. See **ETHNOLOGY** and consult works subjoined thereto.

**ETHNOLOGY**, that branch of the science of anthropology which treats of the races of mankind and seeks to explain their origin and development.

Anthropology is the science which treats of man in relation to himself, to other men and to all nature. It is subdivided into several branches, each of which treats of some special phase of man's natural history. There is a difference in the meaning given by students to the names employed to designate the divisions of the study of man. Ethnology, ethnography, and anthropology have been to some extent interchangeable terms. Each of these branches of knowledge has a special meaning given it in different countries. However, there is becoming a more general acceptance of a definite meaning for these topics. The comprehensive term anthropology is recognized in its general sense to include all others (Keane, Tylor, Mason). The meaning herein given to Ethnology is widely recognized (Keane, Brinton). The use of the term anthropology, to designate societies for the study of man and for sections in national scientific bodies on both sides of the Atlantic, indicates a general tendency to accept the proper meaning of the word.

Ethnology differs from ethnography, which deals chiefly with the collection of facts regarding the families, tribes and races of mankind, in seeking to explain the significance of the information obtained. Ethnography (from *ἔθνος* a people, *γράφειν* to write) is a writing about, a description of, peoples. Ethnology (from

*ἔθνος*, a people, *λόγος* a discourse), attempts to interpret the facts gathered, to explain the causes for the conditions and the relationships of different peoples. Ethnography and ethnology occupy a relation to each other somewhat akin to that of geography and geology. One deals chiefly with existing facts, the other attempts to interpret the history which brought them forth.

Broca says ethnography studies peoples, ethnology races. The following seems a convenient scheme for grouping the branches of anthropology. Substantially it is as follows: Archaeology, Biology, Psychology, Ethnology, Ethnography, Philology, Technology, Sociology and Religion (Mason).

The unity of the race is now generally accepted. From the researches of the physiologist, the anatomist, the philologist and the psychologist we obtain the same testimony as to the specific unity of our race. The place of origin or centre of dispersal is not fixed. From the studies of eminent specialists, it would seem that the land about the shores of the Mediterranean, or the region farther eastward toward India, may claim to be the home of primitive man. About the Mediterranean they settled down like frogs about a pond (Plato).

**Classification.**—For classification, mankind is divided into groups. On account of their distribution, these are sometimes named for geographical divisions. They are also distinguished as families, clans, tribes, nations, peoples and races. In the naming of the latter, family relationships form a prominent factor. It is with both of these lines of classification and the distribution of those discussed under them that ethnology has to do. In these efforts at classification, different schemes have been tried. It is generally accepted that there are two groups of elements of characterization, which are sometimes called criteria. These are physical elements and psychical elements.

The principal physical elements are the bones, the shape of the skull, the facial angle, the color of the skin, color, shape and texture of the hair. Of these, color, probably because the most conspicuous feature, was the first to be considered and formed the basis of all the early classifications. The craniological school founded by the elder Retzius (1796-1860), made the shape of the head the basis of classification, and introduced exact methods into this branch of the subject. This was based on the relative length and breadth of the skull, and accordingly mankind was divided into long-skulled and short, broad-skulled races. Later developments in craniology introduced a third class, representing a mean between the other two. Craniology alone cannot be depended upon to supply sufficient or trustworthy materials for the proper classification of mankind. Nevertheless it has thrown much light upon the subject. Of late years the color, shape and texture of the hair have steadily risen in the estimation of naturalists as a racial test. The hair is now regarded as the most constant of all the physical features and has been made the foundation of their groupings by some of the most eminent anthropologists.

The other physical ethnical elements are of little value separately, but are often useful aids in combination with others. Such are stature; the shape, color and position of the eye; the

size and form of the brain; the shape of the nose and mouth; the superciliary and zygomatic arches, and all such other elements as collectively constitute the broad, flat features of the lower, the oval and regular faces of the higher races.

The psychical elements are less conspicuous, and have but recently been taken into account in classification. It has been said that "Love and hunger rule the world." The former relates to the perpetuation of kind, the latter to self-preservation. Around these two may be grouped the other factors of this class. The following are the principal psychical elements:

(1) Preservative instinct, food, clothing, shelter; (2) Perpetuating instinct; (3) Language; (4) Religion; (5) Government (6) The Arts.

Food, clothing and shelter are the imperative needs of the human species at all ages and under all conditions. Among the prominent topics considered under the sexual impulse are the position of woman, the marriage relation and the line of descent. Language is the chief of the psychical elements. Some perhaps, with Horatio Hale, would make it the sole test of race. The power of religion, both as a constructive and dispersive force, is the repeated testimony of history. The organization and administration of government, whether in its

primitive form or in the more enlightened stage, is of deepest interest. The arts of life find their origin in the rude homes of early man, and have steadily been influential in all human progress. For these have lives been lost, tribes been destroyed, nations been formed, battles been won. They have been the motive power in every effort, the impulse behind every forward movement of mankind from the earliest days to now.

**Race Classification.** There have been so many changes in this world of ours and so many mixtures of ancestral strains that it is impossible to determine certainly to which race certain peoples belong. After successive efforts by able students to classify mankind upon this or that character or group of characters, the tendency now seems to be to return to the earlier classification. To recur to the three greater subdivisions—white, black and yellow; or, Caucasian, Negro, Mongolian.

With all the data gathered and the characters used in succeeding classifications, the original color plan in a general way is as good as we know. Popularly, too, this seems to have struck the fancy. Without thought we speak of a person as white, black or red, as he is a Caucasian, Negro or an American Indian.

Dall divides man into three groups: white, black and yellow. Flower and Lydekker also

GENERAL ETHNOGRAPHIC SCHEME.

Race	Traits	Branches	Stocks	Groups or Peoples
European	Color white Hair wavy Nose narrow	I South-Mediterranean	1. Hamitic	1. Libyan 2. Egyptian 3. East African
		II North-Mediterranean	2. Semitic 1. Euskaric 2. Aryac 3. Caucasian	1. Arabian 2. Abyssinian 3. Chaldean Euskarian Indo-Germanic or Celtic peoples Peoples of the Caucasus
African or Negro	Color black or dark Hair frizzly Nose broad	I Negrillo	1. Central African 2. South African	Dwarfs of the Congo Bushmen, Hottentots Nubian
		II Negro	1. Nilotic 2. Sudanese 3. Senegambian 4. Guinean	
		III Negroid	1. Bantu	Kaffirs and Congo Tribes
Asiatic or Mongolian	Color yellow or olive Hair straight Nose medium	I Sinitic	1. Chinese 2. Tibetan 3. Indo-Chinese	Chinese Natives of Tibet Burmese, Siamese Manchus, Tungus
		II Sibiric	1. Tungusic 2. Mongolic 3. Tartaric 4. Finnic 5. Arctic 6. Japonic	Mongols, Kalmucks Turks, Cossacks Finns, Magyars Chukchis, Ainos Japanese, Koreans
American	Color coppery Hair straight or wavy Nose medium	I Northern	1. Arctic 2. Atlantic 3. Pacific	Eskimos Tinneh, Algonkians, Iroquois Chinooks, Kolosh, etc.
		II Central	1. Mexican	Nahuas, Tarascos Mayas, Chapanecs
		III Southern	1. Atlantic 2. Pacific	Caribs, Arawaks, Tupis Chibchas, Quichuas
Oceanic	Color dark Hair wavy or frizzly Nose medium or narrow	I Negritic	1. Negrito 2. Papuan 3. Melanesian	Mincopies, Aetas New Guineans Feejeans, etc.
		II Malayic	1. Malayan	Malays, Tagalas
		III Australic	2. Polynesian 1. Australian 2. Dravidian	Pacific Islanders Australians Dravidas, Mundas





RACES OF MANKIND



BUSHMAN: 1. Bushman (after *Fritsch*).—2. Namaque woman (after photograph, *F. Abri*). NIGEROIDS: 3. Leango-woman (after Doctor von *Falkenstein*).—4. Man from Darfur (after photograph, *Hagenbeck*). NEGROIDS: 5. Man from the New Hebrides (after *Godeffroy*). 6. Woman from Tasmania (from a photograph, *von Bilow*). 7. Italian woman (from life). 8. Italian (from life). 9. Man from Southwestern Australia (after photograph, *Hagenbeck*). BLACK-HAIRED RACES: 9. Man from Southwestern Australia (after photograph, *Hagenbeck*). BLOND RACES: 11. Danish Girl (from photograph). 12. South Russian (from a photograph). POLYNESIANS: 13. Girl from the Tonga Islands (after *Godeffroy*).—14. Dyak from Borneo (after *Dammann*). MONGOLOIDS: A. 15. Transish-Mongol (after *Prechevalskii*).—16. Kalkas-Mongol woman (after *Prechevalskii*).—B. 17. Chinaman (after portrait, Museum of Ethnology, Berlin).—18. Yakut-woman from the Cheta (after *Altdeddegorf*).—C. 19. North Am. Indian (after photo).—20. South Am. Indian (after *Rohde*). ESKIMO: 21. Koriak woman (from 'Peoples of Russia').—22. Eskimo from Greenland (after photograph, *Hagenbeck*).

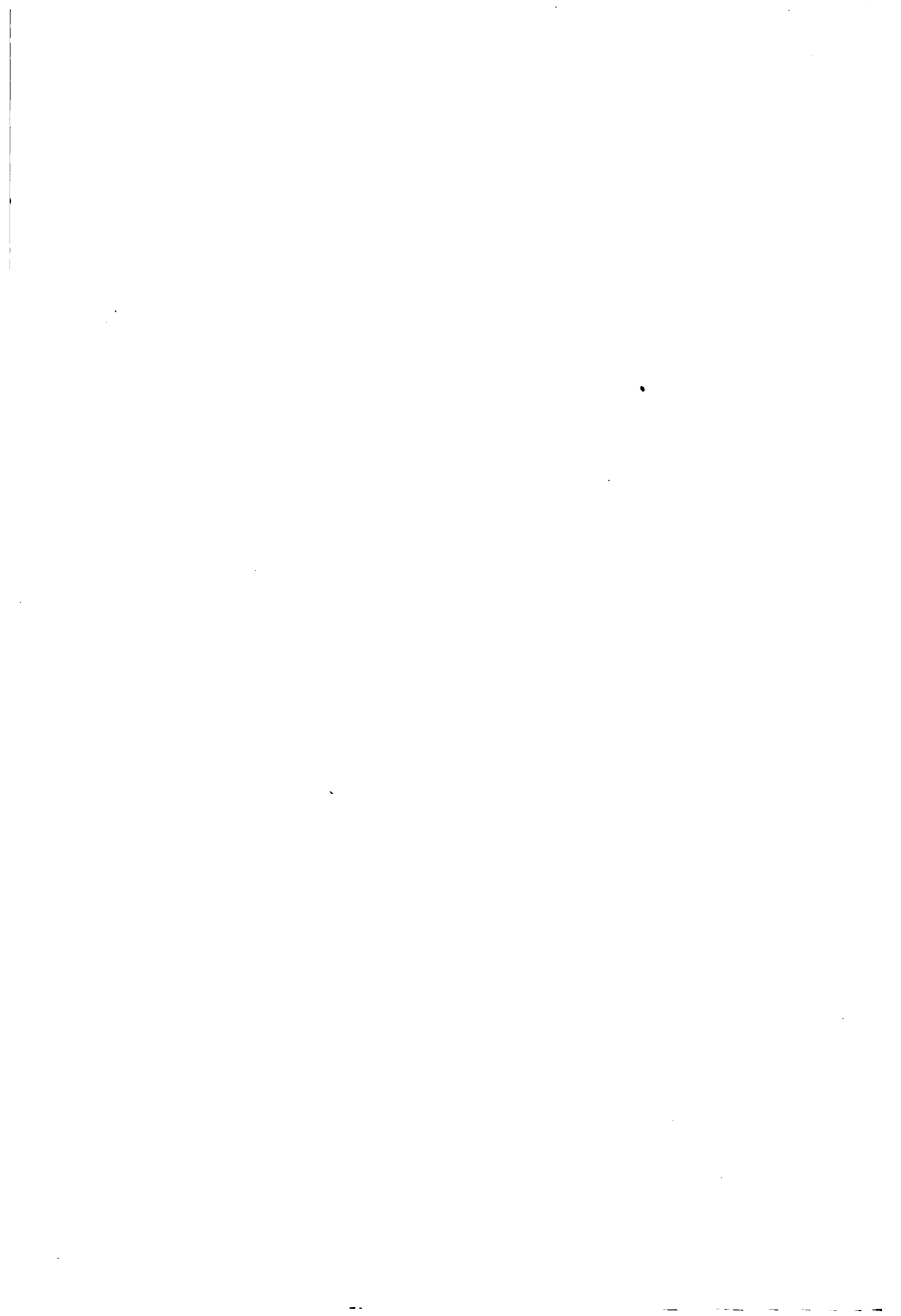



assign all representatives of mankind to three primary divisions. The status of the American aborigines is left unsettled. Keane gives to these a place among the races, making four. Linnæus in his day adopted four primary divisions. He, however, recognized man as a distinct genus, *homo*, having four species: *Homo sp æthiopicus*, *Homo sp mongolicus*, *Homo sp americanus*, *Homo sp caucasicus*. Gerland divides mankind into six races, separating the Dravidians from the other groups. To-day man is considered a single species, having several varieties or races. Blumenbach gives five groups, classified according to the color of the skin. Professor Huxley also designated five groups along somewhat similar lines. Morton used the skull as a basis of classification; Hæckel and Broca the hair; and Hale language.

To one who carefully goes over the different schemes of classifying man, it is apparent that none is wholly satisfactory. Each in some direction overlaps some other. It is by taking all these race criteria so far as they are of value that the most reliable conclusions may be drawn as to the proper classification of mankind. No one set of standards will properly answer. That classification will be most satisfactory which obtains the most help from all the elements. All that we can aim to do is to group under some general and loose fitting subdivisions those members of the species which display the greatest number of similarities. (Brinton). Perhaps it will be as satisfactory to follow the plan of Linnæus and classify the races of men according to geographical areas. Under such a plan we speak of the European race, which in ancient times was confined to Europe and adjacent parts of Asia and Africa; the African race, whose natural home is Africa; the Asiatic race, which is chiefly confined to Asia; the American race, composed of those occupying the western continent before its occupation by Europeans; and, the Oceanic or Australian race, comprising the tribes of Polynesia, Australia and the many groups of islands sometimes included in Oceania. We can use Blumenbach's scheme of dividing them according to the color of the skin. Under it, they are grouped as follows:

1, Caucasian, or white; 2, Ethiopian, or black; 3, Mongolian, or yellow; 4, American, or red; 5, Malay, or brown. Dr. D. G. Brinton enumerated five races of mankind. Their chief characteristics may be summed up substantially as follows: I. The European Race—Traits—Color white, hair wavy, nose narrow, jaws straight, skull variable, languages inflectional, religions ideal. II. The African, or Negro Race—Traits—Color black, hair woolly, nose flat, jaws protruding, skull long, language agglutinative, religions material. III. The Asiatic, or Mongolian Race—Traits—Color yellowish or brownish, hair straight, nose flat or medium, jaws straight, skull broad and high, languages isolating or agglutinative, religions material. IV. The American Race—Traits—Color coppery, hair straight, nose narrow, jaws straight, skull variable, language incorporating, religions ideal. V. The Oceanic Race—Traits—Color dark, hair lank or wavy, languages agglutinative.

Classified in this manner, the human species

presents the subdivision shown in the preceding "scheme."

**The European Race.**—Of the South Mediterranean branch of the European race there are given two divisions, the Hamitic and the Semitic. The former is divided into three groups, the Libyan, Egyptian and East African. The Libyan group extends over Northern Africa from the Atlantic Ocean to the Nile. Some of these tribes are very dark and have been termed "Black Caucasians." Nevertheless, except for color, they are fine representatives of the white race. The Egyptian group is represented by the ancient Egyptians and their descendants, the modern Fellah of the Nile valley and the Copts. These two groups of this branch of the European race have been potent factors in the world's history. The development of the earliest seats of culture, the organization of government, and the establishment of high degrees of civilization have been the work of their representatives. On the contrary the East African group is represented by a number of tribes who are chiefly nomadic and occupy the territory south of the Egyptian group and extending from the Nile to the Indian Ocean. They include the Gallis, Somalis and Agaas.

The Semitic stocks are made up of three groups—the Arabian, Abyssinian and Chaldæan. The most prominent of the first group are the Arabians; the existing tribes best known are the Ishmaelites and Bedouin. They have occupied at different times parts of the Arabian peninsula and now practically cover it all.

The Abyssinian group is supposed to have originated in the region last mentioned and to have been dispersed over Abyssinia and adjacent parts of Africa. They have become mixed with adjoining tribes and a corrupt form of Christianity exists among them. The Abyssinians, Tigre and Amhara are prominent nations. The former is best known.

The third group of Semitic peoples has been called the Chaldæan. This includes the Syrians, Israelites, Samaritans, Babylonians and Jews. They also originated in Arabia and spread out into other lands. The Jew has become worldwide in his dispersal. From these peoples great nations were developed and from them two great religious leaders, Jesus Christ and Mohammed, have sprung.

The North Mediterranean branch is divided into three divisions. They are the Euskaric, Aryac and Caucasian stocks. The only surviving remnant of the Euskaric stock is the Basques of Spain. That they formerly were more widely distributed is generally believed. Their relationship with other peoples is not satisfactorily determined. The most extended and most important of these race stocks is the Aryac. The origin of the Aryans has been a fruitful theme of discussion in recent years. While there is still a difference of opinion on this subject, the majority of writers have accepted the theory of their European origin. The Aryac or Indo-Germanic stock is divided by Brinton into eight groups: Celtic, Italic, Illyric, Hellenic, Lettic, Teutonic, Slavonic and Indo-Iranic groups.

The Lettic or Lithuanian peoples, while comparatively inconspicuous, are in some respects the most interesting of their fellows. They are thought by some students to be the remnant of the original stock and that which

most resembles it. They are located along the Baltic Sea in Prussia and Russia.

The Indo-Iranic group is of special interest because it has the farthest eastern range and for the reason that it is nearest the region which those who believe in the Asiatic origin of the race think was its primitive home. The term *Iranic* is derived from the plateau of Iran, which has been thought by some to be the area of dispersal of the race. The group divides into two divisions, the *Iranic*, whose old representatives were the *Bactrians* and *Persians*. To-day it includes the modern *Persians*, the *Parsees*, generally known as *fire-worshippers*, and the tribes of *Beluchistan*, *Afghanistan* and neighboring regions. The *Indic* branch comprises the peoples occupying *India*. The most prominent of these are the *Hindus*, *Rajpoots* and *Djats*. The typical *Brahmins* probably are the best representatives of the stock.

The *Teutonic* group includes the *Germans*, *English*, *Norwegians*, *Swedes* and *Danes*, and their ancestors, the *Goths*, *Vandals*, *Angles*, *Saxons*, *Norsemen*. These independent, aggressive, progressive races have been conspicuous in the history of the past and the activities of the present. They have spread throughout the world as missionaries of business, education or religion. They are the forces which operate in all progressive government, and are destined to sway the world.

East of these is the *Slavonic* group. It is represented to-day by the *Russians*, *Poles*, *Czechs*, *Bulgarians*, and other tribes of the *Danube* region. Of their ancestors known in history are the *Scythians* and *Massagetæ*. The *Slavonic* tribes to the east, in one direction, came in contact with the *Indo-Iranians* and, in another, with some of the branches of the *Mongolians*. Within comparatively recent times some of them have made remarkable progress in civilization.

The *Hellenic* group comprised the ancient *Greeks* and their relatives. They occupied at an early date the peninsulas of *Asia Minor*, *Greece*, the southern part of *Italy* and contiguous territory. The progress of *Greek* culture is familiar. *Greek* language, literature and art form the basis of education everywhere. Their dominion was one of the world's greatest confederacies. Overthrown by the *Romans* and subsequently by the *Mohammedans*, they were for generations hidden from the view of the progressive world. The *Illyric* stock is situated near the *Greeks* in *Turkey*. It is represented by the *Albanians*. The *Italic* stock covered most of the *Italian Peninsula*. The *Umbrians*, *Etruscans*, *Oscans* and *Latins* were the principal older representatives. They developed the *Roman Empire*, and in the organization and conduct of government and the framing of laws they achieved a front place in the history of the world.

The *Celtic* group, originally spread over western Europe, has largely disappeared. Certain parts of the *British Isles* and the north of *France* contain the surviving members. These are the *Irish*, *Welsh*, *Scotch*, *Maax* and the people of *Brittany*.

The *Caucasic* stock is represented by four groups: *Lesghic*, *Circassic*, *Kistic* and *Georgic*. They occupy the *Caucasus Mountain* region.

**The African or Negro Race.**—The *African* race occupies *Africa* south of the *Sahara Desert*

and of the *Nile Valley*. It is classified in three groups: the *Negrillos*, *Negroes* and *Negroids*. Under *Negrillos* (little *Negroes*) are grouped the *Akkas* and other *pygmies* of the interior region and the small-sized *Bushmen* and *Hottentots* farther south. The characters of some of these tribes are faithfully preserved in figures upon the *Egyptian* monuments. The most striking of these physical features is the peculiar growth and development about the pelvic region. The clicks of the *Hottentot* and *Bushman* languages find no counterpart in any other tongue. The *Negroes* are confined chiefly to western and central *Africa*, ranging east into *Nubia*. They comprise four subdivisions: the *Nilotic*, *Sudanese*, *Senegambian* and *Guinean*. The first is confined to the upper *Nile Valley*. The *Sudanese* group is represented by tribes in *Sudan* and westward. The western coast south of the *Senegal River* is the territory of the *Senegambians*. Farther south toward the *Niger River* are the tribes of the *Guinea* group. This region was the chief source of the slave trade. The descendants of the *Guinea negroes* found throughout the *United States* are living witnesses of the slavery which existed there but a generation ago.

The *Negroids* approach the *Negroes*, but are in some ways quite different from them. Their color is brown rather than black; their hair is "kinky" but not woolly; the nose is straight and not short and flat. They are of two groups—the *Nubian* and *Bantu*. The former are found in *Nubia* and the upper *Nile Valley*. The latter occupies practically all of southern *Africa* except the region of the *Hottentots* and *Bushmen*. Among the better known tribes are the *Kaffirs*, *Bechuanas* and *Zulus*. The *African* race occupies a low stage in culture. It has developed in the restricted area south of the *Sahara* basin. Probably it reached its typical development in the *Niger Valley*.

**The Asiatic or Mongolian Race.**—The *Asian*, or *Mongolian* race, is made up of two divisions—the *Sinitic* and *Sibiric*. The *Sinitic* branch includes the *Chinese*, *Tibetans* and the inhabitants of *Anam*, *Siam*, *Burma* and *Cochin China*. The *Chinese* have occupied their territory from quite early times. They have developed a peculiar civilization and in some particulars reached quite a high stage of culture. While there is considerable difference of opinion whether the arts of ancient *China* developed there or were acquired from the *Aryans* to the westward, it seems probable that in a great measure at least they were indigenous.

The *Sibiric* branch of this race is largely located north of the mountains of central *Asia*, ranging with the *Arctic Circle* from the *Pacific* to the *Atlantic Ocean*. The six groups are the *Tungusic*, reaching from northern *China* toward the *Arctic Ocean* and to *Kamchatka*. The *Mongolic* occupying the vast highlands west of *Manchuria*, *Genghis-Khan* and later *Tamerlane* established two of the wide extended *Mongol* empires. The *Tartaric*, another highland group, has spread from *Turkestan* in several directions. The *Turk* is the most conspicuous representative, though much mixed with other races. The *Finnic* is a group of *Mongols* occupying northern *Europe*. It is represented there by the *Finns* and *Lapps*, and farther south by the *Magyars*. From there it extends east

to the Volga River. The rude tribes fringing the Arctic Ocean in eastern Siberia and reaching to the Pacific are grouped under the name Arctic. The Chukchis and Kamchatkans are of their number. The Japanese and Koreans constitute the Japanese group. The Japanese are the most progressive and advanced of the Asiatic race.

**The Oceanic Race.**—The Oceanic race may be divided into three stocks—Negritic, Malayic and Australic. It occupies Australia, the islands of the South Pacific and Indian oceans and the adjacent shores of Asia. In their migrations, whether along the shores or over the seas, they have so intermingled that their relationships are puzzling. The Negritic stock is represented by the Negritos, including such small peoples as the Mincopies of the Andaman Islands, the Papuans of New Guinea and other islands, and the Melanesians. The Malayic stock is the most conspicuous and energetic of the ocean peoples. Its representatives are found extending almost two-thirds around the world, reaching from Easter Island to Madagascar. The most typical Malays are found in Malacca, Sumatra and Java, while others less marked extend from the Celebes to the Philippines. The Malays farther to the eastward are often called Polynesians. From their traditions it has been possible to obtain a fairly good idea of their successive migrations and of the comparative time of the settlement of the different island groups. They extend from New Guinea to New Zealand, Easter and the Sandwich Islands. The Australic stock includes the different tribes of Australia, the extinct Tasmanians, and, according to some authorities, the primitive peoples of the peninsula of Hindustan. The Australians are very low in culture, nomadic, lacking government and wear little or no clothing. "The life of these savages proves to be of undeveloped type, alike in arts and institutions, so much so, that the distinction of being the lowest of normal tribes may be claimed for them."—(E. B. Tylor).

**The American Race.**—The American race includes those peoples occupying the western continent at the time of its discovery by white men. For the purpose of study they may be divided into seven groups: Arctic, North Atlantic, North Pacific, Mexican, Inter-Isthmian, South Atlantic, South Pacific.

The Arctic groups include the Eskimo and Aleutian peoples. They occupy the shores of the oceans in Arctic America and extend from Labrador to Greenland. In the North Atlantic group are some Indians of wide range. The Athabascans extend from the valleys of the Yukon and lower Mackenzie to Arizona; while farther to the southward, reaching into Mexico, the warlike Apaches are of this group. The Algonkins ranged from Newfoundland to the Rocky Mountains and from the Churchill River Valley and Hudson Bay southward throughout the Ohio and Mississippi valleys to the Tennessee River. These included most of the Indians encountered by the early settlers. Their names are more or less familiar to us from history. The intelligent Iroquois, the formidable Dakotas (Sioux), the southern Indians, some of whom built mounds within historic times, and the tribes of the interior plains also

belong to this division. The North Pacific group includes a number of tribes west of the Rocky Mountains, many of which are small and represent distinct linguistic stocks. Several of these tribes have the head artificially deformed. These include the Flatheads and Nez Percés (Pierced Noses). The Cliff-dwellers and Pueblo tribes of the arid regions of the southwestern United States are placed here. The Mexican group is notable because of the state of civilization attained by the Aztecs, its best-known tribe. The organization developed, government established, education acquired, buildings constructed and arts pursued were unequalled by any tribe of the American race. The Mayas were the most important tribe of the Inter-Isthmian group. They were builders of note, elaborate decorators of stone and mural artists. The South Atlantic group occupied the Atlantic coast of South America. They were chiefly wandering tribes without settled habitations. The Quichuas of Peru are the best-known tribe of the South Pacific group. They attained higher civilization than any other South American tribe. They developed agriculture, domesticated animals, constructed large buildings of stone, were expert workers in metals and devised a method of record keeping by means of strings and knots called quippus. See ANTHROPOLOGY; ETHNOLOGY; MAN, CHRISTIAN ANTHROPOLOGY; MAN, PREHISTORIC RACES OF; EMBRYOLOGY, HUMAN.

**Bibliography.**—Boas, F., 'The Mind of Primitive Man' (New York 1911); Brinton, 'Races and Peoples'; id., 'The American Race'; Deniker, J., 'The Races of Man' (London 1900); Gerland, 'Ethnography'; Keane, A. H., 'Ethnology' (2d ed., New York 1906); id., 'Man Past and Present' (ib. 1900); Morgan, L. H., 'Ancient Society' (1878); Ratzel, F., 'History of Mankind' (3 vols., ib. 1904); Thomas, W. I., 'Source Book for Social Origins' (Chicago 1909), with an extensive bibliography; and Tylor, E. B., 'Anthropology'; id., 'Primitive Culture' (2 vols., New York 1891).

AMOS W. BUTLER,

*Zoologist and Anthropologist, Indianapolis.*

**ETHNOLOGY, Bureau of American.** See SMITHSONIAN INSTITUTION.

**ETHOLOGY.** See BIONOMICS.

**ETHYL**, the organic radical  $C_2H_5$ , which occurs in many carbon compounds, but which is not known to exist in the free state. Its most important compounds are ethyl hydrate, or ethyl alcohol (see ALCOHOL) and ethyl oxide, popularly known as ether (q.v.); but the iodide,  $C_2H_5I$ , which is formed by acting upon ethyl alcohol with iodine in the presence of phosphorus, is also of much importance in synthetic chemistry.

**ETHYL NITRATE.** See NITROUS ETHER.

**ETHYLAMINE**, an amine (q.v.) in which one or more of the hydrogen atoms of ammonia,  $NH_3$ , is replaced by the radical ethyl,  $C_2H_5$ . Three compounds of this sort are possible, and all have been actually prepared. When only one of the hydrogen atoms of the ammonia has been replaced, the resulting compound,  $NH_2C_2H_5$ , is known as mono-ethylamine, or ethyl monamine; and it is this substance which is understood when the word ethylamine is used

without qualification.  $\text{NH}(\text{C}_2\text{H}_5)_2$  is known as diethylamine, and  $\text{N}(\text{C}_2\text{H}_5)_3$  is called triethylamine. All three are formed when absolute alcohol is heated with zinc chloride, in closed tubes, to  $500^\circ \text{F}$ .; and they may then be separated by the crystallization of their picrates. Ethylamine (that is, the mono-amine) may also be prepared by boiling cyanic ether with an aqueous solution of caustic potash, absorbing the liberated gas by passing it through hydrochloric acid, and finally drying the ethylamine hydrochloride that is so formed, and distilling it with quicklime. All three of the ethylamines are alkaline, all smell strongly of ammonia and all combine with acids to form salts. The mono-amine is a colorless, caustic, inflammable liquid, burning with a yellow flame, having a specific gravity of 0.70, boiling at  $68^\circ \text{F}$ ., and not solidifying at  $220^\circ$  below zero,  $\text{F}$ . Diethylamine (which may be prepared by heating the mono-amine with ethyl bromide is also volatile, colorless and inflammable, with a specific gravity of 0.72, and boils at  $133^\circ \text{F}$ ., under ordinary atmospheric pressure. Triethylamine is an oily liquid, alkaline, and similar to the other two in general character. It has a specific gravity of 0.73, boils at  $194^\circ \text{F}$ ., and its critical temperature (according to Pawlewski) is  $513^\circ \text{F}$ . (See CRITICAL POINT). Triethylamine is but slightly soluble in water; diethylamine dissolves in water freely; mono-ethylamine mixes with water with a considerable rise in temperature, and the probable formation of a hydrate, though it is entirely expelled again, upon boiling.

**ETHYLENE**, a gaseous hydrocarbon having the formula  $\text{C}_2\text{H}_4$ , and constituting the first member of the olefine series. It is formed in the dry distillation of numerous organic bodies, and constitutes 4 to 5 per cent of ordinary coal gas. It is most conveniently prepared for laboratory purposes by mixing 1 part of alcohol with 4 parts of sulphuric acid, adding enough sand to form a paste, and heating the mass over a flame. The sand takes no part in the chemistry of the process, but merely serves to regulate the action. The sulphuric acid, owing to its affinity for water, removes the elements of water from the alcohol, and thereby liberates the ethylene,  $\text{C}_2\text{H}_5.\text{OH}=\text{H}_2\text{O}+\text{C}_2\text{H}_4$ . Ethylene is a colorless gas, which burns with a bright flame, a five-foot burner, using the pure gas, yielding a light of 68 candle-power. It may be condensed to a transparent liquid which boils, under ordinary atmospheric pressure, at  $153^\circ \text{F}$ . below zero, and freezes at  $272^\circ \text{F}$ . below zero. Ethylene is an unsaturated compound, and combines directly with hydrogen when mixed with that gas and led over platinum black; the product of the combination being ethane,  $\text{C}_2\text{H}_6$ . Mixed with three times its own volume of oxygen, and fired by a spark, ethylene explodes with great violence. When it is mixed with chlorine in the dark, combination takes place according to the formula  $\text{C}_2\text{H}_4+2\text{Cl}=\text{C}_2\text{H}_4\text{Cl}_2$ , the new substance being an oily fluid, known as ethylene dichloride, or "Dutch liquid." It is on account of this reaction that ethylene was formerly called "olefiant" (or "oil-forming") gas. It will be observed that the foregoing reaction is an additive one. In diffuse daylight chlorine attacks the dichloride of ethylene, with the formation of more highly chlorinated substitution products, of which the highest is  $\text{C}_2\text{Cl}_4$ .

**ETHYLENE DICHLORIDE**. See DUTCH LIQUID.

**ETIENNE**, Charles Guillaume, shārl gē yōm ā-tē-ēn, French dramatist: b. Chamouilly, 6 Jan. 1778; d. Paris, 13 March 1845. Under the First Empire he was censor, editor-in-chief of the *Journal of the Empire*, and a member of the Academy. He took part in Napoleon's campaigns in Italy, Germany, Poland and Austria. At the Restoration he was expelled from the Academy, and thereafter as editor of the *Constitutional* was a power on the side of the opposition. His comedies give proof of brilliant fancy, elegant style, and great constructive skill; 'The Two Sons-in-Law' is the best comedy of the Imperial Era, and not unworthy of Molière. He composed many farces, vaudevilles, operettas and spectacular pieces, which had unbounded success; and his operas, 'Cinderella' and 'Joconde,' were the delight of Paris. He wrote a 'History of the French Theatre.'

**ETIENNE DU MONT**, ā-tē-ēn dū mōn (Fr. "Saint Stephen of the Mount"), a fine church of mediæval Paris. It was founded in 1220; its completion and restoration were begun in 1517, and the building reached its present perfection in 1626. The shrine of Saint Genevieve, heroine and patron saint of Paris is its principal point of antiquarian interest, but it is also the burial-place of Pascal and Racine.

**ETIOLATION**, ē'ti-ō-lā'shōn, the alteration in the color and the structure of plants due to the absence of light during growth. The most noticeable changes are paleness and elongation of the stems. The elongation is due to the extension of the cells, and the paleness to the non-development, arrested development or destruction of the chlorophyll or green coloring matter of the plant. Other phenomena are imperfect development of leaves, altered method of branching and various modifications of tissues, especially in the imperfect development of the cell walls, which do not attain normal thickness. Agriculturally, etiolation is either a fault to be shunned or a useful process. In the first case it is often responsible for the "lodging" of wheat and other grain-crops sown too thickly, the bases of the stems being shaded so much that the cells fail to develop normal strength, and when the heads form the wind easily beats down the plants. The sprouting of potatoes, turnips, etc., is also undesirable. But etiolation is utilized in the blanching of various plants, such as asparagus and sea-kale, and especially salads such as celery, endive and chicory. The process involves the exclusion of light by means of earth banked around the stems, by boards, paper, etc., or by tying the outer leaves loosely over the inner ones as with endive or with cauliflower. Rhubarb is often grown in darkness. In general, tenderness and modifications in flavor are the chief ends sought in the process.

**ETIOLIN**, in botany, a name given by the older authors to the carotin of etiolated plant structures. See CAROTIN.

**ETIQUETTE**, Madame, the nickname of the Duchesse de Noailles, mistress of ceremonies at the French court in the time of Marie Antoinette, because of her rigid adherence to the formalities or prescriptions for the various ceremonies at court.

**ETIQUETTE**, *èt'ī kēt*, a collective term for the established ceremonies and usages of society. Among courts the Byzantine and Spanish courts, and the French court under Louis XIV and Louis XV, were noted for the strictness of their etiquette. Social etiquette consists in so many minute observances that a tolerable familiarity with it can be acquired only by a considerable intercourse with polite society. Quickness of sympathy and a certain fineness of observation are more needed for proficiency in this sphere than mere power of intellect. The term is derived from the French word *etiquette*, originally a slip of paper affixed to a packet to indicate its contents. This term has come to mean the various decorums to be observed in the ordinary intercourse of life, and especially the comportment on state occasions perhaps from the custom formerly of distributing tickets or slips of paper to each person containing the rules to be observed by him or her at the ceremony. The word is also used by the members of certain professions to designate the rules to be observed by the members, e.g., "legal etiquette," etc. In the latter sense, however, it has been supplanted by the word "ethics."

**ETIVE**, *èt'iv*, **Loch**, an inlet from the Firth of Lorne, in north of Argyllshire, west coast of Scotland. The river Awe, the outlet of Loch Awe, and the river Etive flow into it. At Connel Ferry, about three miles from the sea, it is barely 200 yards wide, and is crossed by a ridge of sunken rocks. The depth here at low water is six feet; the inflowing tide, which rises 14 feet, rushes with tremendous force through the narrow channel, breaking into raging foam which may sometimes be heard miles away. Dunstaffnage, a 13th century castle, once a royal fortress, is near its mouth.

**ETLAR**, **Carit**, pseudonym of KARL BROSNÖLL, Danish realistic novelist: b. Fridericia, 7 April 1816; d. 1900. His first story was 'The Smuggler's Son' (1839); of his later writings, the historical tale of 'The Queen's Captain of the Guard' and the realistic story 'The People in Need' (1878) are the most popular; his verse also has merit. An edition of his collected works was published in 1859-68, with an additional collection in 1873-79; a new addition appeared in 1888.

**ETNA**, or **ÆTNA**, a volcano in the eastern part of the province of Catania, on the island of Sicily, and the largest active volcano in Europe and the highest mountain in Italy. Directly north is the valley of Alcantara, on the west and south, the valley of Simeto, and on the east, the Ionian Sea. From the waters on the east, which are in depth from 5,000 to 6,000 feet, Etna rises cone-like to a height of about 10,875 feet; but on the south and west it seems formed of superimposed mountains, the terminal being surrounded by a number of cones, all of volcanic origin, about nine of which are of considerable size. The circumference at the base is about 90 miles. Around the mountain and at the lower slope are a number of villages, cultivated fields, groves of olive-, orange-, fig- and date-trees; and a little higher up is a belt of forest with oak, birch, beech and coniferæ. Above 7,000 feet vegetation is scanty, the cone is almost bare; rocky precipices, lava beds, masses of ashes and scorixæ are

visible at its summit except where covered by snow. A deep depression, Val de Bove, on the eastern side, was once the principal crater; and frequently lava has issued out of the sides of the mountain, thus forming small cones and craters, about 200 of which are now distinctly marked. The summit is usually altered with every eruption. From the summit may be seen the whole of the island of Sicily, the Lipari Islands, Malta and Calabria.

The eruptions of Etna have been numerous and many of them destructive; more than 80 have been recorded, 11 of which occurred before the Christian Era. That of 1169 A.D. overwhelmed Catania and buried 15,000 persons in the ruins. In 1669 the lava spread over the country for 40 days, and 10,000 persons are estimated to have perished. In 1693 there was an earthquake during the eruption, when over 60,000 lives were lost. One eruption was in 1755, the year of the Lisbon earthquake. Among more recent eruptions are those of 1852, 1865, 1874, 1879, 1886, 1892, 1909 and 1911. An eruption is ordinarily preceded by premonitory symptoms of longer or shorter duration. In Greek mythology there are found frequent allusions to Etna, especially in the legends of Enceladus and Hiphæstus. Consult Dana, 'Characteristics of Volcanoes'; Kneeland, 'Volcanoes.'

**ETNA**, Pa., borough in Allegheny County, on the Allegheny River, the Baltimore and Ohio and a branch of the Pennsylvania railroads. It is really a suburb of Pittsburgh, with only the Allegheny River between. The chief industries are in connection with the iron and steel products for which this part of the State is famous. It has rolling mills, furnaces, steel mills, galvanized-pipe works and other manufactures. The waterworks and electric-light plant are owned by the borough. Pop. 5,830.

**ETON**, England, village and parish, in the county of Buckingham, on the Thames, 21 miles west-southwest of London. It consists principally of one narrow street which has of late years been much improved. An iron bridge across the Thames connects Eton with Windsor, from which it is separated only by the river. Eton derives its celebrity from its college. Pop. 3,192.

**ETON COLLEGE**, the most famous of English public schools, was founded by Henry VI in 1440, under the name of "The College of the Blessed Virgin Mary Beside Windsor." The present collegiate edifice was begun in 1441 and the whole of the original structure was completed about 1523. Important additions were made in 1846, and also in 1889. This school was intended originally for the benefit of the sons of worthy but poor parents, and also for the support of 25 poor infirm men; and was to be maintained out of the incomes from the royal demesne lands. Now the students admitted are the sons of the gentry and nobility, and so numerous are the applicants that it is usual to enter the names at birth. The scholarships are open to all British subjects; but candidates must be 12 years or over and not more than 14 years, and must pass an examination. A certain number of the students, not under 17 years, are elected each year to scholarships at King's College, Cambridge. The number of pupils on the foundation is limited to 70, but the number out-

side, called oppidans, who board and lodge in the houses of the masters is about 1,000. The course of instruction is mainly classical, but modern languages, mathematics and the natural sciences are given now a due share of attention. The college roll includes the most famous names in more recent English history in nearly every department of service, and especially among statesmen and administrators. Consult Cust, 'Eton College'; Lyte, 'History of Eton College' (1440-1898).

**ETOROFU**, ă-tō-rō-foo, or **ITURUP**, ē-too-roop', (1) an island; (2) a strait; in the most northerly part of Japan. The island belongs to the Kurile group. Area, 1,500 square miles.

**ETOSA LAKE**. See **KUNENE**.

**ETOURDI, L'**, a comedy of Molière, which was first produced at Lyons in the year 1653. See **MOLIÈRE**.

**ETOWAH MOUND**. See **MOUND BUILDERS AND MOUNDS**.

**ETRETAT**, France, a fashionable summer resort on the English Channel, 17 miles east of Havre, in the department of Seine-Inférieure. It contains a casino, bathhouses, a fine strand and many summer residences. It is famed for its gatherings of litterateurs and artists. Pop. (commune) 1,973.

**ETRURIA**, ē-troo'ri-ā (Greek *Tyrrhenia*), the name anciently given to that part of Italy which corresponded with the greater part of modern Tuscany and part of Umbria, and was bounded by the Mediterranean, the Apennines, the river Magra and the Tiber. The name *Tuscia*, for the country, came into use in late times, while *Tusci*, as well as *Etrusci*, was used by the Romans as the appellation of the people from an early period. The oldest inhabitants of the country belonged, according to the accounts of the ancients, to the Umbrian stock and were dispossessed by the Tyrrhenians or Tyrsenians, a people who came by sea and who were generally believed to be Lydians. These again were in early times subjected by another race who called themselves *Rasena* and who finally became incorporated with the Tyrrhenians proper, the whole nation then being called *Tuscans* or *Etruscans*. These *Rasena*, by ancient writers usually confounded with the Tyrrhenians, entered Italy at a very early period from the north and gradually took possession of the whole country from the Alps, Ticino and lower Adige on the south.

To what race the Etruscans belonged is unknown and our ignorance is equally great with regard to their language, remains of which still exist in numerous inscriptions mostly on tombs. It appears to have been quite distinct from the languages of the rest of Italy, but attempts to connect it with the Greek, Celtic, Germanic or Semitic languages have had little or no success. The characters used are essentially the ancient Greek and were either introduced from *Magna Græcia* or possibly from Corinth. Etruria was very early a confederation under the rulers of the 12 principal cities, each of which formed a republic by itself. The chiefs of these republics were styled *lucumones*, who were also the priests and generals and held their meetings in the temple of Voltumna, where they deliberated together on the general affairs of the country. In

all the cities there appears to have been an aristocracy, toward which the mass of the common people stood in the relation of clients, though there would no doubt be a body of entirely free men resembling the plebeians at Rome. The religion of the Etruscans offers a subject of great difficulty, but it is at least certain that it had many points in common with the religious systems of the Sabines and Latins, while in some respects it shows evidences of an Eastern origin. Among the deities may be mentioned *Tina* or *Tinia*, corresponding to the Latin *Jupiter*; *Cupra*, corresponding to *Juno*; *Menerfa* (*Minerva*); *Sethlans* (*Vulcan*); *Turms* (*Mercury*); and *Aplu* or *Apulu* (*Apollo*).

What may be called the Etruscan Era commenced about 1044 B.C. They became the dominant race in northern and central Italy and Rome itself fell under their rule and was ruled by Etruscan kings. In the maritime wars they were in alliance with Carthage against Greece. The zenith of their power was in the 6th century B.C., when with the Greeks and the Phœnicians they shared the maritime supremacy of the Mediterranean. Their naval power was shattered in 474 B.C. by Hiero I of Syracuse and after this their decline was rapid. The Gauls swarmed over the Alps in 396 B.C.; in 351 the southern Etruscans made submission to the Romans; and the process of conquest was completed by the subjugation of the northern Etruscans in 282 B.C. After this they became merged in their conquerors, on whom they exercised a considerable influence in religious, social and political life.

The chief occupations of the Etruscans were agriculture and commerce, both maritime and overland. Grain, wine, timber, cattle and wool seem to have been the principal articles of trade. The staple food of the common people was pulse, but the upper classes were notorious for extravagance in their diet as well as in dress and in furniture. Their knowledge of the arts and sciences is said to have been derived mainly from Greece and in a less degree from Egypt. The iron mines and copper mines in the interior of Etruria were worked at a very remote period and the metallurgical skill shown by the Etruscans was obviously connected with their proficiency in the art of working in bronze, silver, gold, etc. Of Etruscan architecture our knowledge is limited; but their cities were laid out on a quadrangular plan and strongly fortified. The so-called Tuscan order seems to be little else than a modification of the Doric. Of their temples there exist no traces; the theatres have been more fortunate, that at Fiesole showing how much in this form of construction they owed to the Greeks. The sepulchres, which were always subterranean, but frequently having superstructures of an architectural character surmounting them, present many varieties of construction.

For articles in terra-cotta the Etruscans were especially celebrated. These were not restricted to small objects, but embraced statues and figures of large size, with which the exteriors and interiors of their temples were adorned. Closely related to this branch of art was the Etruscan pottery, in the manufacture of which they excelled; but the only extant productions of this class that can be said to be genuine are

the red ware of Arretium and the black ware of Clusium ornamented with figures in relief, many of them of a grotesque and strongly-marked Oriental character. On the other hand, numbers of the painted vases popularly known as Etruscan vases are undoubtedly productions of Greek workmen, the subjects, the style and the inscriptions being all Greek. The skill of the Etruscans in works of bronze is attested by many ancient writers, and also by numerous extant specimens. The style of art characteristic of these works is stiff and archaic, having some resemblance to the early Greek, though some of the existing specimens exhibit more freedom of design and great beauty of execution. The bronze candelabra, of which many examples have been preserved, were eagerly sought after both in Greece and Rome. Another branch of art which seems to have been peculiar to this people was that of the engraved bronze mirrors, a considerable number of which has been discovered, some quite recently. These mirrors were polished on one side, and have on the other an engraved design, taken in most cases from Greek legend or mythology. Consult Dennis, 'The Cities and Cemeteries of Etruria' (1892); Seymour, 'Up Hill and Down Dale in Ancient Etruria' (1910).

**ETRURIA**, Kingdom of, the name given to the province of Tuscany, in Italy, when, in 1801, Napoleon formed of it a kingdom, and made Florence the capital. In 1808 he incorporated it with the French Empire, and in 1809 his sister, Elise Bacciocchi, was made Grand Duchess of Tuscany. When Napoleon became an exile in 1814, Tuscany reverted to Austria, and Frederick III became king.

**ETRUSCAN**. See **ETRURIA**.

**ETRUSCAN VASES**, a class of beautiful ancient painted vases made in Etruria, but not strictly speaking a product of Etruscan art, since they were really the productions of a ripe age of Greek art, the workmanship, subjects, style and inscriptions being all Greek. They are elegant in form and enriched with bands of beautiful foliage and other ornaments, figures and similar subjects of a highly artistic character. One class has black figures and ornaments on a red ground—the natural color of the clay; another has the figures left of the natural color and the ground painted black. The former class belong to a date about 600 B.C., the latter date about a century later, and extend over a period of about 350 years, when the manufacture seems to have ceased. The subjects represented on these vases frequently relate to heroic personages of the Greek mythology, but many scenes of an ordinary and even of a domestic character are depicted. The figures are usually in profile.

**ETSCH**. See **ADIGE**.

**ETTINGHAUSEN**, Konstantin, Baron von, Austrian geologist and botanist: b. Vienna, 1826; d. 1897. He was educated in his native city and became professor of botany and of medical natural history at the Joseph Academy in 1854. He removed to Gratz in 1871 and seven years later was engaged by the British Museum to arrange the collection of fossil plants there. His works include 'Physiotypia Plantarum Austriacarum' (2 vols., 1856-73); 'Physiographis der Medizinalpflanzen' (1862);

'Beitrage zur Erforschung der Phylogenie der Pflanzenarten' (7 vols., 1877-80).

**ETTLINGEN**, ət'ling-ən, Germany, town in the grand duchy of Baden, on the Alb, five miles south of Karlsruhe. It is an ancient place, containing some Roman remains; is entered by three gates, and has an old castle with gardens, town-house, hospital, normal and other schools, manufactures of machinery, linen and cotton goods, starch, leather and paper. Near the town the Archduke Charles of Austria here suffered defeat at the hands of Moreau, 9 and 10 July 1796. Pop. 9,407.

**ETTMÜLLER**, Ernst Moritz Ludwig, lood'vig ət'mül-lër, German philologist and historian: b. Gersdorf, Saxony, 5 Oct. 1802; d. Zürich, 15 April 1877. He was graduated at Leipzig; lectured at Jena on the German poets of the Middle Ages; in 1833 went to the Gymnasium at Zürich and in 1863 he became professor of German literature in the University of Zürich. He made extensive researches in German mediæval literature and was author of 'German Dynasty Founders' (1844); and other epic poems, besides the 'Anglo-Saxon Lexicon' (1852). He also translated 'Beowulf' into German.

**ETTOR**, Joseph J., American industrial agitator: b. 1886. He came into prominence during the labor troubles at Paterson, N. J., Brooklyn, N. Y., and elsewhere, but attained his greatest attention in conducting the textile workers during the strike at Lawrence, Mass., in 1912. For his methods in this affair he was sentenced to nine months' imprisonment, having been held responsible for the death of a woman shot in a riot there on 29 Jan. 1912. After his release he was again prominent in the waiters' strike in New York in 1913 and the barbers' strike in the same city in 1914. He is prominently identified with the Industrial Workers of the World, of the executive council of which he became a member.

**ETTRICK**, ət'rik, a district of Scotland, in Selkirk, through which the Ettrick water runs. It is now a sheep pasture, denuded of wood, but in ancient times it formed part of Ettrick Forest, which included the whole country as well as parts of Peebles and Edinburghshire. The "Ettrick Shepherd," James Hogg, was a native of this district. Consult Craig-Brown, 'History of Selkirkshire' (Edinburgh 1886).

**ETTRICK SHEPHERD**, The. See **HOGG**, JAMES.

**ET TU BRUTE** ("and thou also, Brutus"), the words supposed to have been uttered by Julius Cæsar at the moment he was stabbed by Brutus. There is, however, no ancient authority for attributing this utterance to Cæsar, and it is probable that the popular impression is due to the use of these words by Shakespeare in his play, 'Julius Cæsar.' Other dramatists of the same period also used the phrase.

**ETTWEIN**, ət'vin, John, American Moravian bishop: b. Trendenstadt, Würtemberg, 29 June 1721; d. Bethlehem, Pa., 2 Jan. 1802. He came to America in 1754 and for nearly 50 years worked among the Moravians as evangelist, pastor and bishop. He traveled thousands of miles, oftentimes on foot, preaching in 11 of the 13 colonies and in what is now the State of

Ohio, "in cities, in villages, in homesteads, from pulpits, in the open air, in courthouses and barns to many and very different classes of men," as he himself wrote. Among the Indians, too, he worked with great success. In 1776-77 he rendered noble services to the sick and wounded of the American army in the general hospital at Bethlehem, Pa. Elected bishop in 1784, he presided over his Church for nearly 17 years, displaying the soundest judgment in matters of polity and a fine personal heroism in critical circumstances. In 1787 he founded the Society for Propagating the Gospel Among the Heathen, which still exists, richly endowed, and is the bulwark of the extensive Moravian mission work. He became proficient in the language of the Delaware Indians, prepared a dictionary and phrasebook of it, and in 1788 compiled an account of the language with a vocabulary, which has since been published by the Pennsylvania Historical Society. Old age compelled his retirement from active service in 1801.

**ETTY, William**, English painter: b. York, 10 March 1787; d. there, 13 Nov. 1849. He worked long without much recognition, but at length in 1820 won public notice by his 'Coral Finders.' In 1828 he was elected an academician. Among his works, which were greatly admired, are a series of three pictures (1827-31) illustrating the 'Deliverance of Bethulia by Judith'; 'Benaiah one of David's Mighty Men'; 'Women Interceding for the Vanquished.' All these are very large pictures, and are now in the National Gallery of Scotland. Others of note are 'The Judgment of Paris'; 'The Rape of Proserpine'; 'Youth at the Prow and Pleasure at the Helm.' In coloring and the representation of the nude he displayed high ability.

**ETUDE**, at first a term to designate a musical composition written for the purpose of developing some particular point, as arpeggio, etc., has come to mean a study for a concert performance with many technical difficulties. Some of the latter by famous masters are of special beauty and elegance, of which we may mention here the famed études of Chopin, Liszt and Schumann, which rank among the finest compositions for the piano. For the violin the compositions of Fiorillo, Kreutzer and Paganini are justly famous.

**ETYMOLOGICUM GUDIANUM.** See **ETYMOLOGICUM MAGNUM.**

**ETYMOLOGICUM MAGNUM** (Gr. "the great etymological glossary, or dictionary"), the sole lexicon of size surviving from the Byzantine age of Greek learning. It is evidently a compilation from other works of the same class, and bears no author's name. The book may be attributed to the 10th century. It consists of a number of quotations from the works of ancient grammarians, arranged alphabetically. It may have received its name from its first critical editor, Sylburg, or from its printer, Calliergus. The book is of high philological value, although many of the derivations of words contained in it are fanciful and utterly unscientific. Consult Cohn, 'Griechische Lexicographie' (in 'Griechische Grammatik' of Burgmann-Thumb, Munich 1913); Gaisford, 'Etymologicum Magnum' (Oxford 1848); Reitzenstein,

'Geschichte der griechischen Etymologica' (Leipzig 1897); Sturz, 'Etymologicum Gudianum' (Leipzig 1816-20).

**ETYMOLOGY**, that branch of philology which deals with the investigation of the origin or derivation and of the original signification of words. It forms a subsidiary part of the science of comparative philology, and, though it has occupied the attention of the learned and the curious in every age, it is only within the 19th century that its study has been pursued on really scientific principles. Ignorance, or what is still more dangerous, half-knowledge, has often suggested false etymologies and many more have sprung from that excess of confident and self-sufficient ingenuity which will not take plain words like *beef-eater* and *welsh-rabbit* for what they are. Folk-etymology, properly so called, has played an important rôle in the development of languages. The words that the people have known from infancy are for them things, but it is quite different from the new terms they meet. These arrest their curiosity, and, as they believe that every word has its signification, they seek for this, guided by resemblances of sound with words already known, and consequently reach conclusions often hopelessly distorted by false analogies. We see the same illogical process in the Old Testament interpretation of personal names, applied conveniently after the fact; in the Homeric explanation of the names of gods and men; in the quaint etymologies so common in the mediæval writers and in such moderns as Thomas Fuller; in the vagaries of Celtic topographers; and even in the pages of some modern dictionaries it is possible to find such a statement as that the English word *news* is derived from a certain conjunction of the points of the compass, north, east, west and south. These whimsical etymologies were laughed at by Dean Swift, whose *ostler* = *oat-stealer*, was a stroke of genius, but have not yet disappeared; and, indeed, the modern ideas of method in etymology are hardly at all beyond the point attained by the grammarians of Alexandria and by Varro among the Romans. It was the birth of philology and the study of the languages of the East that made a scientific etymology possible. It no longer sought the relation of the words of a single language exclusively within itself, but extended its view to the whole group of cognate tongues, or, wider still, to a whole family and became a new science under the name of Comparative Grammar. Grimm's Law was the first finger-post that pointed out the path; among his greatest successors are Curtius and Fick. The Teutonic revival in England in the 19th century commenced the history of English upon an historical method, from which has grown a really scientific English etymology, as seen in the dictionaries of Professor Skeat and Dr. Murray. No more useful chart of warning could be given than the former's canons for etymology: "Before attempting an etymology, ascertain the earliest form and use of the word and observe chronology. If the word be of native origin, we should next trace its history in cognate languages. If the word be borrowed, we must observe geography and the history of events, remembering that borrowings are due to actual contact." See Curtius, 'Grundzüge der Griech-



ischen Etymologie' (1879); Fick, 'Vergleichendes Wörterbuch der Indo-germanischen Sprachen' (1874-76); Palmer, 'Folk-Etymology' (1882); Skeat, 'The Science of Etymology' (1912); also see LANGUAGE, SCIENCE OF, and authorities quoted thereunder.

**ETZEL.** See **ATILA**.

**EU**, è (Lat. *Auga*), France, town in the department of Seine-Inférieure, two miles above the mouth of the Bresle, 17 miles northeast of Dieppe. It was in the castle belonging to this place that William the Conqueror married Maud of Flanders. The town was burned to the ground in 1475, by order of Louis XI, to prevent it from falling into the hands of the English. It has several small manufacturing establishments. Pop. of commune 5,651.

**EUA**, ā-oo'ā, or **EOA**, a small island belonging to the Friendly Islands, owned by Great Britain. It is about 10½ miles long by three wide. The climate of all the islands of the Tonga group, to which the Friendly Islands belong, is but slightly higher than that of the Samoan Islands, just north. Pop. about 400.

**EUANTHIUS**, Roman grammarian: d. Constantinople, 358 A.D. He wrote a commentary on Terence which was extensively used by Donatus in his own commentary of that author. His treatise 'De Fabula' was also incorporated by Donatus. Consult Wessner, 'Æli Donati... Commentum Terenti' (Vol. I, Leipzig 1902).

**EUBCEA**, ū-bē'a, formerly called **NEGRO-PONT**, a Greek island, the second largest island of the Ægean Sea. It is 90 miles long, 30 in greatest breadth, reduced at one point to four miles. It is separated from the mainland of Greece by the narrow channels of Egripo and Talanta, and is connected with the Bœotian shore by a bridge. There are several mountain peaks, one over 7,000 feet. The island is well wooded and remarkably fertile. Wine is a staple product and cotton, wool, pitch and turpentine are exported. The chief towns are Chalcis and Karysto. The island was anciently divided among seven independent cities, the most important of which were Chalcis and Eretria. Successively held by the Athenians, the Persians, the Romans and the Venetians, it was taken by the Turks in 1470, and in 1830 was delivered from their control. With some small islands it forms a modern nomarchy, with a population of 116,903.

**EUBULIDES** (ū-bū'lidéz) **OF MILE-TUS**, Greek philosopher: the best known of the disciples of Euclid of Megara, flourished about the middle of the 4th century B.C. His life was a struggle against Aristotle, in which by a captious logic he sought to prevail against good sense. A partisan of the Megaric principle, that there is nothing real but what is always one, simple and identical, he immediately found an adversary in the founder of the great contemporary school which made experience the condition of science. He attacked the peripatetic doctrine, like Zeno of Elea, by striving to show that there is none of our experimental notions which does not give place to insolvable difficulties. He wrote a number of comedies and a work on Diogenes the Cynic. See **MEGARIAN SCHOOL OF PHILOSOPHY**.

**EUBULIUS.** See **CYRILLUS AND METHODIUS**.

**EUBULUS**, ū-bū'lūs, Greek comic writer: fl. at Athens about 375 B.C. His subjects were chiefly mythological and many of his plays contained parodies of the tragic poets, especially Euripides. He is credited with having written over 100 plays, of which only some fragments and 50 titles have survived. Consult Koch, 'Comicorum Atticorum Fragmenta' (Leipzig 1884); Meinke, 'Fragmenta Comicorum Græcorum' (Berlin 1839-57).

**EUCAINE.** See **COCAINE**.

**EUCALYPTOCRINUS**, a genus of fossil Crinoidea found in the Silurian beds of the Niagara group in America and in England and Scotland. Its special peculiarity is that its 20 arms rest in vertical compartments divided by 10 partitions attached to the tegmen and supported by the interbrachials.

**EUCALYPTUS**, ū-ka-līp'tūs, a genus of trees and a few shrubs of the family *Myrtaceæ*. The species, of which there are about 300, are characterized by simple symmetrical leaves, whose edges usually turn toward the sun; generally white, bell-shaped flowers, sometimes solitary, but commonly in terminal or axillary umbels near the ends of the twigs; calyx-lobes joined to form a lid, which falls off when the flower opens (from this feature the genus is named); numerous stamens; and many-seeded, angular fruit-capsules. With the exception of about half a dozen species which are natives of the East Indies and the Malay Peninsula, the members of the genus are indigenous to Australasia, where they are among the most common forest trees. The various species are highly valued for planting in parks and along avenues; for the gum-resin which oozes from their trunks; for the volatile oil contained in their leaves; for the tannin obtained from their bark; and for the fibre of their inner bark. They have been widely distributed by man in warm climates, particularly in the British possessions. Above all they are valued for their timber, which is extensively used for wharf, ship, bridge and house building, telegraph poles, railroad ties, implements, furniture, etc. To obtain it the trees are frequently ring-barked about the beginning of the warm season so as to exhaust the sap as much as possible. After standing until the end of the dry season they are felled. Some of the species are among the largest living trees of the world. Specimens exceeding 450 feet in height and with a girth of 50 feet are occasionally reported.

Few species are hardy, but many are cultivated for ornament where they can be given shelter from cold winds, or where, like other tender ornamental plants, they can be removed to a house during the winter. In California a majority of the species thrive in the open air and are valued for their striking habits of growth, their foliage, etc. They are readily propagated from seeds sown in light, sandy soil. The seedlings should be transplanted when about four inches tall and again at rather frequent intervals, to ensure the formation of fibrous roots near the surface, thus to secure them a good start when transplanted to final quarters. Transplanting should always be done in cool, moist, cloudy weather. When once established they demand no further attention than ordinary pruning and training.

Among the best-known species are the fol-

lowing: *Eucalyptus globulus*, the blue-gum, which often exceeds 300 feet in height, has bluish or grayish smooth bark, except at the base. It is noted for its rapid growth, the unpleasantly flavored nectar of its blossoms, which is very attractive to bees, and its ability to withstand long periods of drought. It is the most frequently planted species in California, where it is also becoming naturalized by means of its seeds. It is also planted to some extent in Florida and other Gulf States, and is said to survive a temperature as low as 20° F. It is one of the most valuable of timber trees and is one of the chief sources of oil of eucalyptus. A somewhat hardier species (*E. viminalis*), popularly known as manna gum, attains about the same size, but has either dark-colored persistent bark or light-colored deciduous bark. In California, where it also is spreading like the former, it has withstood lower temperatures and made phenomenal growths, in some instances exceeding 70 feet in height and 3 feet in girth in 12 years. It is valuable for its nectar, of which bees are very fond, but its timber is less valuable than that of the preceding species, being less strong. It is frequently used for fencing, shingles and other purposes where strain is not expected. Perhaps the most valued is *E. marginata*, the jarrah tree or wood, which often attains heights exceeding 70 feet without the development of any limbs, and at that height often has a girth of 15 feet. It is not hardy. Its wood is especially valued for wharf and ship building, since it is not attacked by the teredo or shipworm. It is also highly esteemed for underground work, such as ties and telegraph poles, and, being easily worked and polished, is popular for house finishing and furniture. The largest species is probably *E. amygdalina*, the peppermint-tree, which is also noted for its abundant yield of oil. Its timber is not strong, but is largely used for staves, shingles, building, etc. *E. robusta*, the swamp-mahogany gum, is perhaps the species most frequently planted in swampy places. Its timber is remarkably durable and is used, like that of *E. marginata*, but is somewhat less esteemed. It is one of the finest of avenue trees, and one of the best for bees because of its abundant nectar and profuse bloom.

In medicine, oil of eucalyptus is used for its antiseptic and stimulating properties. It is very widely used in affections of the nose, mouth and bronchi, and in diseases of the bladder and urethra. It makes a very agreeable and efficient drug to add to antiseptic mouth-washes and is useful internally as an intestinal anti-fermentative. Trees of eucalyptus have been planted, especially in low marshy places, with a belief in their beneficial effects against malaria. It is frequently asserted that they have a direct action on malaria. By the aid they furnish in converting marshes into dry land they also help to prevent the development of mosquitoes, some forms of which are known to be the chief agents in the spread of malarial disease. (See MALARIA; VOLATILE OILS). Consult Bailey, 'Cyclopedia of American Horticulture' (1914); Mueller, 'Eucalyptographia'; Bentham, 'Flora Australiensis' (Vol. III); Pepper, 'Eucalyptus in Algeria and Tunisia, from an Hygienic and Climatological Point of View' (Proceedings of the American Philosophical Society, Vol.

XXXV, pp. 39-56); Cooper, 'Forest Culture and Eucalyptus Trees.'

**EUCCHARIS**, ū'ka-ris, (1) a genus of plants of the natural order *Amaryllidaceae*, the species which, mostly natives of Colombia, are perennial herbs with perennial bulb-like rootstocks, broadly ovate leaves and very showy white flowers in umbels upon long, strong scapes. They are very popular hot-house plants because of their beauty and the prolificacy of their long-lasting flowers. They are easily grown in course fibrous soil which will permit of abundant watering without danger of stagnation. Partial shade and rather high temperature are also needed. The best-known species is probably *E. grandiflora*, which is popularly known as star-of-Bethlehem and Amazon lily. The flowers of this species are borne upon a scape often exceeding 18 inches in height and bearing two to four star-like and very fragrant flowers, often four inches in diameter. (2) a genus of mollusks; also known as Glaucus; (3) the typical genus of Chaldeians, sub-family Eucharinae.

**EUCCHARIST**, ū'ka-ris't, in the Roman Catholic Church, the sacrament of the body and blood of Jesus Christ, and also the Christian covenant sacrifice. Regarding the Eucharist as a sacrament, the Roman Catholic Church teaches that it is the true body and blood of Jesus Christ under the "species" or appearances or physical properties of bread and wine. The institution of this sacrament by Christ is recorded in the three synoptic gospels and in Saint Paul's first letter to the Corinthians. The name given to the sacrament comes from the expression in the original Greek text of Luke xxii, 19, *εὐχαριστίας* (eucharistesas), "having given thanks." The words of institution, as given by the same evangelist, are: "This is my body which is given for you. . . . This is the chalice, the new testament in my blood, which shall be shed for you." The perpetuation of this sacrament is commanded in the words, "This do for a commemoration of me." (1 Cor. xi, 24). A year before the institution of the sacrament Jesus Christ in a discourse at Capernaum, spoke of his flesh being "meat indeed" and his blood "drink indeed"; and it is important to note the circumstances in which he employed those extraordinary expressions. He had already said: "I am the bread of life," at which the Jews murmured. Thereupon Jesus, instead of modifying the expression which offended them, re-enforced it, saying: "The bread which I will give is my flesh for the life of the world." At this the Jews again murmured, but Christ does but emphasize the doctrine in the words already quoted. And not only the Jews were scandalized by these speeches: many of Jesus' disciples even would no longer listen to him; they "went back and walked no more with him." Would the apostles also desert him? and he elicited from them a profession of implicit faith in his words, however "hard" his sayings might be.

And that attitude of the apostles is the attitude of the Roman Catholic Church. Those words of her Founder and the many other announcements he made touching this sacramental mystery, the Roman Catholic Church from apostolic times has received in their plain literal interpretation -- the interpretation put upon

**EUCALYPTUS**



**Forest Cover for Parks, Los Angeles, California**



**Avenue Shade Trees, near Santa Monica, California**



them by all who heard them, Jews, disciples, apostles, and by Jesus Christ himself: the Roman Catholic Church teaches that in the Eucharist is contained "truly, really and substantially" the body and blood of Jesus Christ, together with his soul and divinity. Here nothing is added to, nothing taken away from, the words of Christ, and nothing explained away in those "words of eternal life." And when in the 11th century the Church's reading of those words as denoting a "true, real and substantial" change of the bread and wine into Christ's body and blood was challenged by Berengarius, who, more "spiritually-minded" than the apostles of Jesus Christ, would fain see in Christ's words only a figurative, symbolical presence of his body and blood in the sacrament, the Roman Catholic Church adopted the fittest possible word to express the change wrought in the bread and wine—the word Transubstantiation: in the Eucharist the substance of bread and wine remain no longer underlying the outward appearances, "species" of bread and wine: what underlies them now is the body and blood of Christ. Such is the teaching of the Roman Catholic Church with regard to the real presence of Jesus Christ in the Eucharist.

But the Eucharist is not only a sacrament: it is also the perpetual New Covenant sacrifice, believed to have been foretold by the prophet Malachi, as rendered in the Vulgate, which differs slightly from the authorized Anglican version: "From the rising of the sun even to the going down thereof, my name is great among the Gentiles, and in every place there is sacrifice, and there is offered to my name a clean oblation" (Mal. i, 10-11). And the Roman Catholic Church teaches concerning the Eucharistic sacrifice or the Mass that "it is one and the same sacrifice with that of the cross: the victim is one and the same, Jesus Christ, who offered himself, once only, a bloody sacrifice on the altar of the cross. The bloody and unbloody victim is still one and the same, and the offering upon the cross is daily renewed in the Eucharistic sacrifice, in obedience to the command of our Lord, 'Do this in remembrance of Me.'"—*Catech. Conc. Trid., cap. de Eucharistia Sacr.*

**Bibliography.**—Adamson, R. M., 'Christian Doctrine of the Lord's Supper' (New York 1905); Armstrong, 'Sacraments of the New Testament' (ib. 1880); Bridgett, T. E., 'History of the Holy Eucharist in England' (new ed., London 1908); Bright, W., 'Aspects of Primitive Church Life' (ib. 1898); Dalgairns, J. D., 'The Holy Communion: Its History, Philosophy and Practice' (3d. ed., Dublin 1868); Denzinger, Heinrich, 'Enchiridion Symbolorum et Definitionum' (Würzburg 1854); Dimock, N., 'On Eucharistic Worship in the English Church' (London 1911); Franzelin, 'Die Eucharistia' (Rome 1868); Gardner, P., 'Origin of the Lord's Supper' (London 1893); Gore, Charles, 'Dissertations' (ib. 1895); id., 'The Body of Christ: An Inquiry into the Institution and Doctrine of Holy Communion' (New York 1901); Groton, W. M., 'Christian Eucharist and the Pagan Cults' (ib. 1914); Harrison, J., 'Answer to Dr. Pusey's Challenge Respecting the Doctrine of the Real Presence' (2 vols., ib. 1871); Jacob, G. A., 'The Lord's Supper Historically Considered' (Oxford 1884); Jeauffre-

son, H. H., 'The Holy Eucharist' (London 1887); Keating, J. F., 'The Agapé and the Eucharist in the Early Church' (ib. 1901); Kidd, B. J., 'The Later Mediaeval Doctrine of the Eucharistic Sacrifice' (ib. 1898); McGiffert, A. C., 'History of Christianity in the Apostolic Age' (New York 1897); Macnaught, J., 'Coena Domine: An Essay on the Lord's Supper' (London 1878); Meyrick, Frederick, 'The Doctrine of the Church of England in Holy Communion' (New York 1908); Mortimer, A. G., 'Catholic Faith and Practice' (Philadelphia 1898); Moule, H. C. G., 'The Supper of the Lord' (London 1899); Perowne, J. J. S., 'Doctrine of the Lord's Supper' (ib. 1887); Pusey, E. B., 'The Real Presence of the Body and Blood of Our Lord in the Holy Eucharist' (Oxford 1857); Sanday, William, 'Different Conception of Priesthood and Sacrifices' (New York 1900); Stanley, A. P., 'Christian Institutions' (London 1871); Stone, D., 'History of the Doctrine of the Holy Eucharist' (2 vols., New York 1901); Strong, T. B., 'The Doctrine of the Real Presence' (ib. 1899); Thalhofer, V., 'Das Opfer des alten und neuen Bundes' (Regensburg 1870); Weizsäcker, C., 'The Apostolic Age' (2 vols., London 1895); Wilberforce, R. I., 'Doctrine of the Holy Eucharist' (ib. 1853); Cardinal Wiseman, 'Lectures on the Real Presence' (Dublin 1852).

**EUCHLORINE**, a name given by Sir Humphry Davy (q.v.) to the yellow gas obtained by acting upon potassium chlorate with hydrochloric acid. Davy believed it to be a new oxide of chlorine; but it is now known to be a mixture of chlorine and chlorine peroxide, ClO<sub>2</sub>. It has powerful bleaching and disinfecting properties, but it is frightfully explosive, and should never be prepared nor handled save by an expert chemist, provided with proper safeguards, and with a full previous knowledge of its properties.

**EUCHOLOGION**, ū-kō-lō'jī-ōn, the liturgical and ritual book of the Greek Church, corresponding to the Missal, which is the Pontifical and Ritual of the Latin Church. The Uniate Greek Church, or Church of the Greek Rite in communion with the See of Rome, has a separate Euchologion. The Euchologion contains the liturgies, the order of daily services with prayers and litanies, and finally a collection of sacraments and sacramentals, with various rules, canons and blessings. The first printed edition was published in 1526 at Venice and since then the successive official Greek editions have been printed there. There are, however, other editions published both in Athens and Constantinople. There is also an abstract, called 'Small Euchologion.' There is no English translation, but M. Rajewsky has translated it into German under the title 'Euchologion der Orthodox-Katholischen Kirche, etc.' (Vienna 1861-62).

**EUCHRE**, ū'kēr, a game of cards, regarding the origin of which nothing definite is known. For a long time it was the most generally played parlor game after whist in the United States. The pack of cards consists of 32, but sometimes only 24 are used, being an ordinary "deck," minus the deuce, trey, four, five and six spots of each suit. The game is usually played by two, three or four persons,

the most interesting party being four, two playing on each side as partners. When choice of partners and first dealer has been decided five cards are dealt, usually two at once, then three, or the contrary. Having dealt five cards to each player, the dealer turns up the next card for trumps, leaving it, face upward, on top of the balance of the pack. The cards rank in value as follows: The best euchre card is the knave of trumps; the second best is the knave of the suit of the same color as the trump. The former card is called the "right bower," the latter the "left bower." After the right and left bowers the cards rank as at whist, the knaves of the color not turned as trumps falling into their regular place as at whist. The object of the game is to take tricks. The score is five points, unless otherwise agreed. In two-handed euchre the following rules apply: The non-dealer may "pass," or "order up" the trump. Should he pass, then the dealer may take up the trump and discard. In that case the dealer must make three tricks or be "euchred," which counts two points for the adversary, but if he makes the three tricks (or four), he counts one point. Should he make all five tricks, it is termed "a march," and counts him two on the score. The non-dealer has the first lead, after which he who takes the trick leads. Suit must be followed if possible; otherwise any card may be played. Should the non-dealer "order up" the trump he must make three tricks or be "euchred," which counts two for his opponent, if he win three tricks (or four), having ordered up the trump, he scores one point. Should he make "a march," he scores two. If both players pass (the dealer turning down the trump), and then both decline to make a trump, there must be a new deal. Either party naming a new suit for trump must make the three tricks or be "euchred." In four-handed euchre the same counts are made and the same rules practised as in the two-handed game, together with the following: The opportunity to "pass," "order up," "assist," or "play alone" goes around in rotation, beginning with the player on the left of the dealer. "To assist" is for the partner of the dealer to say "I assist," which has the same effect as ordering up the trump, and is subject to the penalty of two points to the adversary, should three tricks not be secured by the party "assisting" and his partner. Either partner ordering up a trump or making a trump may "play alone," that is, play his hand singly against the other two, his partner not playing his hand that round at all. "Progressive euchre" is played by a number of participants at separate tables, the successful players moving up in a regular order. A prize is generally awarded to the two winners. There are also a number of other varieties: Railroad, French, Call-Ace or Australian Euchre, and Napoleon. Consult Cady, A. H., 'Euchre' (in 'Spalding's Home Library,' Vol. I, No. 6, New York 1895); Foster, R. F., 'Call-Ace Euchre' (London 1904); id., 'Foster's Complete Hoyle, etc.' (New York 1914); Jessel, F., 'A Bibliography of Works in English on Playing Cards and Gaming' (London 1905); Seaver, C. M., 'The Standard Guide to Progressive Euchre' (Boston 1885).

**EUCKEN, Rudolf Christoph**, German philosopher: b. Aurich, East Frisia, 5 Jan. 1846. His father died while he was a

child, but he enjoyed the loving care of his mother, a woman of marked intelligence and warm sympathies. His early education was received in his native town and he came under the influence of the theologian and philosopher, William Reuter, who was one of his teachers. It is generally believed that Reuter stimulated his interest in religion. He studied at Göttingen where he entered the philosophical classes of Hermann Lotze. It was characteristic of the man that, while he admired Lotze's acuteness, he was not attracted by it. Thus early his anti-intellectualism displayed itself. Eucken took his doctor's degree at Göttingen, not in philosophy, but in classical philology and ancient history. After his graduation, he spent five years as a gymnasium teacher. In 1871 he was called to the University of Basel, and in 1874 he received a call to succeed Kuno Fischer as professor of philosophy at Jena. Here he settled permanently, refusing invitations to other places. During the quiet years passed as a teacher at Jena, he worked out his own philosophy of history and life. In 1908 he received the Nobel prize for literature. His international fame dates from this period. In 1911 he visited England and received a cordial reception, and the next year he came to the United States to deliver a course of lectures at Harvard.

Eucken's early philosophical work was along historical lines. In fact, his first publications deal with Aristotle. Gradually, his thinking became more original and constructive and moved in the direction of a philosophy of religion. His philosophy can best be described technically as a spiritual activism founded on a NeoKantian theory of knowledge. He makes constant use of history to show the growth of life-systems which soar beyond anything for which the physical world can account. This inner spiritual life of man is real and tremendously significant. While it is conditioned by physical processes, it is not reducible to them. Spiritual values are achievements which must be actively appropriated by those who come after. Mere acceptance is not enough. We have already referred to his anti-intellectualism. This does not consist of a distrust of reason but of a feeling that concepts are not sufficient. There must be experiencing as well as knowing. Philosophy must aim at a profound penetration of life in the light of eternal values.

There can be no doubt that Eucken has struck an important note. His attack upon mere traditionalism, for instance, is valuable. So is his stress upon personal idealism. But the technical thinker is likely to criticize his neglect of theory of knowledge and his disregard of the mind-body problem. These lacunæ need filling in, as even his most ardent disciples admit. Yet, when all is said, Eucken must be accorded a high place among modern thinkers. He has helped to free religion from its mythological setting and to bring into relief its ethical content. He has been a very prolific writer. The following are his chief works: 'Die Methode der Aristotelischen Forschung' (1872); 'Die Grundbegriffe der Gegenwart' (1878; this was published in its third edition under the title 'Geistige Strömungen der Gegenwart'); 'Geschichte der philosophischen Terminologie' (1879); 'Die Einheit des Geisteslebens' (1888); 'Die Lebensanschauungen

der grossen Denker' (1890; English title 'The Problem of Human Life'); 'Der Kampf um einen geistigen Lebensinhalt' (1896); 'Der Wahrheitsgehalt der Religion' (1901; English title 'The Truth of Religion'); 'Hauptprobleme der Religionsphilosophie der Gegenwart' (1907; English title 'Christianity and the New Idealism'); 'Sinn und Wert des Lebens' (1908; English title 'The Meaning and Value of Life'); 'Religion and Life' (1911); 'Can We Still be Christians' (1914). The two best expositions of Eucken's philosophy in English are Boyce Gibson's 'Rudolf Eucken's Philosophy of Life' (New York 1907), and W. Tudor Jones's 'An Interpretation of Rudolf Eucken's Philosophy.' Consult, also, Höffding's discussion in 'Modern Philosophers,' Meyrick Booth's 'Eucken: his Philosophy and Influence,' and O. Siebert's 'R. Euckens Welt und Lebensanschauung.'

ROY WOOD SELERS,

Professor of Philosophy, University of Michigan.

**EUCLASE**, *ū'klās*, a very rare gem mineral, a basic silicate of beryllium and aluminum, HBe Al SiO<sub>4</sub>. It occurs in Brazil, Siberia, and Austria, in brilliant, transparent, colorless to pale-green or blue crystals of monoclinic forms, with perfect cleavage and has a hardness of 7.5. Its specific gravity is 3.1. There is a fairly extensive, scientific literature, a bibliography of which as well as all available scientific details regarding Euclase may be found in Dana, E. S., ed., 'The System of mineralogy of James D. Dana' (6th ed., New York 1914).

**EUCLID OF ALEXANDRIA**, Greek mathematician: fl. about 300 B.C., taught geometry at Alexandria in the reign of Ptolemy I (323-285 B.C.), and extended the boundaries of mathematical science. The severity and accuracy of his method have never been surpassed. There is very little known regarding his life, Proclus (412-485 A.D.) forming the chief source for our information. His chief work, *ταστοιχεια*, is known as 'Elements' and has formed for many generations the principal introduction to the study of geometry. It consists of 13 books, though some editions contain two additional books, which, however, are almost without doubt not the work of Euclid. There also have been preserved six other works: 'Data,' 'Introduction to Harmony,' 'Section of the Scale,' 'Phænomena,' 'Optics' and 'Catoptrics.' Concerning some of these, however, it is doubtful whether Euclid was the author or not. Even more doubtful is the authorship of some fragments sometimes ascribed to him. From quotations, etc., it has been well established that he wrote four other works of which, however, nothing is in existence now: three books on 'Porism,' two books on 'Curves,' four books on 'Conic Sections' and one book on 'Fallacies.' The 'Elements' have come to us indirectly through the Arabs who made a number of translations of which, however, only one, made in the 13th century, has been printed (Rome 1594). It is claimed that the first retranslation into Greek from Arabic was made by Adelard of Bath in the 12th century. On this there was based the first printed Greek edition edited with comments by Campanus of Novara (Venice 1482), which, however, is not very reliable. The first translation into Latin, made by B. Zam-

berti, was published in Venice (1505). The first reliable Greek text was printed in Basel (1533) and edited by S. Grynæus. Other editions were brought out by D. Gregory (Greek and Latin, Oxford 1703); F. Peyrard (3 vols., Paris 1814-18); E. F. August (two parts, Berlin 1826-29); T. L. Heath (3 vols., Cambridge 1908). His complete works have been edited by M. Curtze (Leipzig 1899) and by J. L. Heiberg and H. Menge (Leipzig 1883-96). There have also been many translations into almost all the modern languages. The first English translation was made by H. Billingsley (London 1570); the first French by D. Henrion (Paris 1615); the first German by J. Scheybl (Augsburg 1555). There are also a large number of commentaries, almost every new editor for many years feeling it his duty to attempt a new and original, and, therefore, in many cases useless commentary. Consult Anon., 'The Elements of Euclid' (in *Dublin Review*, Vol. XI, p. 330, London 1841); Dodgson, C. L., 'Euclid and His Modern Rivals' (London 1879); Heiberg, J. L., 'Litteraturgeschichtliche Studien über Euklid' (Leipzig 1882); Hultsch, F., 'Eukleides' (in *Pauly-Wissowa*, 'Real-Encyclopädie der classischen Altertumswissenschaft,' Vol. VI, Stuttgart 1907); Riccardi, P., 'Saggio di una Bibliografia Euclidea' (four parts, Bologna 1887-90); Smith, T., 'Euclid: His Life and System' (New York 1902).

**EUCLID OF MEGARA**, Greek philosopher, the founder of the Megaric school of philosophy: b. about 450 B.C.; d. about 380 B.C. He was a pupil of Socrates, after whose death, 399 B.C., he retired to Megara (most probably his native city) and set up a school of philosophy, in which he blended the doctrines of the Eleatic school with those of his master. He adopted the Eleatic notion of one universal unchangeable existence, and upon this he engrafted the ethical views of Socrates. From its subtlety and disputativeness, the school of Euclid was sometimes called the Dialectic or Eristic. He wrote six dialogues of which only one small fragment has been saved.

**EUDEMONISM**, the doctrine that happiness (Gr. *eudaimonia*) is the chief good. Happiness, according to Aristotle, is the activity of soul in accordance with virtue, virtue being the mean between excess and defect as determined by reason. As pleasure and life are inseparably joined together, the one is therefore essential to the other, and the former is a necessary part of all human activity. See ETHICS; ENERGISM.

**EUDEMUS OF RHODES**, Greek philosopher and the disciple of Aristotle. He wrote many works, most of which were in defense of the philosophy of his master; of these the most celebrated is the 'Eudæmian Ethics,' published as a part of the writings of Aristotle. He wrote also a history of mathematics and astronomy, now lost, but of which a commentary remains to us in a work on Euclid by Proclus and in the works of other writers we have fragments. All these fragments were published by Mullach in 'Fragmenta Philosophorum Græcorum' (Vol. III, 1881). Consult Gow, History of Greek Mathematics' (Cambridge 1884).

**EUDES**. See ODO.

**EUDES**, Duke of Aquitania: d. 735 A.D. He ruled that portion of France from the Loire to the Pyrenees and in 721 inflicted a serious defeat on the Arabs, who had besieged Toulouse. Ten years later Charles Martel began his incursions into Aquitania and the Arabs took advantage of this state of affairs to again invade France; Eudes joined forces with Charles to repel the invader and the allied armies won the battle of Tours in 732. Consult Vic and Vaissette, 'Histoire generale de Languedoc' (16 vols., Toulouse 1872-1904).

**EUDES, Jean**, the venerable French clergyman and founder of the Catholic congregation known from his name as the Eudists: b. Ri, 14 Nov. 1601; d. Caen, 19 Aug. 1680. He was educated at the Jesuit College of Caen and in 1623 entered the Congregation of the Oratory at Paris and rose to be superior of the Oratory at Caen in 1639. In 1643 he founded the Congregation of the Mission Priests of Jesus and Mary for the training of priests in missionary work. This society came to be known by the name of their founder, took no vows, were under the jurisdiction of the ordinary, and were at liberty to leave the congregation at any time they pleased. They received papal approval in 1674 and were regarded with jealousy by the Oratorians, especially after the latter became affected with Jansenism which the Eudists reprobated. The congregation spread rapidly throughout France but suffered in the debacle of the Revolution. In 1826 it was reorganized and has since spread to Canada. Eudes also founded a society for the rescue of fallen women which still exists. Pope Leo XIII bestowed on Eudes in 1903 the title of "Author of the liturgical worship of the Sacred Heart of Jesus and the Immaculate Heart of Mary." In 1908 the canonical process for his beatification was instituted in Rome. Consult Montzey, 'Le Père Eudes et ses instituts' (Paris 1869).

**EUDIALYTE**, ū-dī'a-lit, rhombohedral red mineral of vitreous lustre, translucent or nearly so; its hardness, 5.5; specific gravity, 2.90 to 3.01. It consists principally of silicates of iron, zirconia and lime. There are two varieties, eudialyte proper, of which the double refraction is positive, and eucolite, in which it is negative. It is found in North Greenland, Norway and Arkansas.

**EUDIOMETER**, an instrument employed in the analysis of gaseous mixtures. It was originally designed for ascertaining the quantity of oxygen contained in any given bulk of elastic fluid. The first instrument of this kind was constructed by Joseph Priestley. In one form of eudiometer two platinum wires are inserted near the top of a graduated glass tube open at the bottom. An electric spark is introduced by these wires. The process involves the explosion and combustion of one of the constituents to be determined. The operation may be conducted in a trough of mercury or over water. See GASOMETRIC ANALYSIS.

**EUDISTS**, ū'dīsts, a congregation or society of secular priests founded in the 17th century by a priest named Eudes for the purpose of conducting ecclesiastical seminaries and giving "missions" in parish churches, for the revival of religious zeal and the conversion of sinners. The members of the society take no religious vows, but they live in common and are volun-

tarily subject to the orders of their superior. They do not wear any habit to distinguish them from the rest of the secular clergy. Their first house was established at Caen in Normandy 1643; the membership at that time consisted of Eudes and eight other priests. In his time Eudes conducted 110 missions in various places in the kingdom. The institute never spread to other countries. Eight or more Eudists were among the priests who were butchered in the wholesale slaughter of priests, monks and bishops at the Carmes, Paris, September 1792. The society was broken up during the French Revolution, many of the members seeking refuge in England. In 1826 the apostolate was revived and resumed with ardor and great success.

**EUDO DE STELLA**. See EON.

**EUDOCIA**, ū-dō'shī-a, Roman empress: b. Athens, about 393; d. Jerusalem, about 460. She was a daughter of Leontius the philosophical sophist. After the death of her father, who left nearly all his property to his two sons, she went to Constantinople for the purpose of complaining of this injustice to the emperor, Theodosius II. There she embraced the Christian religion, was baptized as Eudocia and became empress 421 A.D., through the efforts of Pulcheria, sister of Theodosius (421). Pulcheria in reality ruled the royal household and Eudocia appears to have bowed to her will in everything. Finally, however, they quarreled over religious matters and Pulcheria was banished from court; but she succeeded in again securing her influence there and Eudocia was afterward divorced or retired from Constantinople and spent the remainder of her life in Jerusalem, engaged in acts of devotion. She is said to have written some Greek poems and also a life of Christ. Consult Diehl, 'Figures byzantines' (Paris 1906); Gregorovius, 'Athenais' (Leipzig 1892); Ludwig, 'Eudocia Agusta Carminum Reliquia' (Königsberg 1893); any good history of the period.

**EUDOXIA**, ū-dōk'sī-a, Byzantine empress: wife of Arcadius, emperor of the West: d. 409. She was the daughter of Banto a Frankish general of Theodosius. Eutropius the eunuch, intriguing against Rufinus, chief minister of Arcadius, induced the emperor to take her to wife, instead of marrying the daughter of Rufinus, as the latter had designed. Eutropius soon after this union caused Rufinus to be put to death and succeeded him. Eudoxia, if we may believe John Chrysostom, was an infamous creature, although at one time winning his admiration and profuse acknowledgments by an open profession of religious earnestness. She was a woman of strong passions and resolute will, and when Eutropius insulted her by saying that as he had raised her so he could debase her, she appealed to the weak Arcadius who at once degraded Eutropius from all his honors and ordered his statue in the market place of Constantinople to be destroyed. Chrysostom so vehemently inveighed against the court life of Eudoxia that she caused him to be banished in 403, but popular clamor, added to the panic caused by an earthquake, induced her to recall him. But her enmity caused his second exile in 404. She survived this persecuted prelate only two years, and if she were too impatient under the almost Aristophanic invective of a bishop



who was more a monk than a courtier, she was probably sincere in her anxiety to rescue the feeble Arcadius from the dominion of a minister like Eutropius, and the best act she ever did in her life was to bring this monster of profligacy and corruption to the end of his career.

**EUDOXIA**, Roman empress, who was the daughter of Theodosius II: b. Constantinople, 422; d. about 463. She was married to her cousin Valentinian III, emperor of the West, after whose death, by the hands of emissaries of the senator Maximus, she was constrained to espouse the latter. Maximus subsequently had the folly to reveal to her the part which he had taken in the murder of Valentinian, and when the time for vengeance seemed to her to have come she invited to Italy Genseric, king of the Vandals, at whose approach Maximus was murdered. Genseric delivered Rome to pillage and bore away with him to Africa Eudoxia and her two daughters.

**EUDOXIA FEODOROVNA**, tsarina of Russia: b. 1669; d. 1731. At 19 she became the wife of Peter the Great, but her adherence to the Conservative party caused her husband to look on her with little favor and in 1698 for refusing to consent to a divorce she was imprisoned in a convent at Susdal. In 1718 she was brought to Moscow for trial on a charge of adultery and forced to confess her guilt. Thereafter she was confined in the monastery of Staraya Lodoga, but on the accession of her grandson, Peter II, in 1728, she was set at liberty and returned to Moscow, where she died.

**EUDOXIANS**, ū'dōk'sī-anz, followers of Eudoxius, who from 356 A.D. was bishop of Antioch, in Syria, and from 360 to his death in 370 bishop and patriarch of Constantinople. He was successively an Arian, a Semi-Arian and an Aëtian. Respecting the Trinity, he believed the will of the Son to be differently affected from that of the Father.

**EUDOXUS** (ū-dōk'sus) OF CNIDOS, Greek astronomer, lived about 370 B.C., was the scholar and friend of Plato. All his works are lost, but the poem of Aratus on astronomy makes us acquainted with the extent of his astronomical knowledge. Eudoxus seems to have been the first to introduce an astronomical globe into Greece and this may account for the great reputation which he acquired and long continued to enjoy. He is said to have discovered that the solar year is six hours longer than 365 days and to have invented a sun dial. He was considerable of a philosopher too, in his day; and he held that the *summum bonum* of all things is pleasure, which is the aim of everyone. Consult Letronne, 'Sive les écarts et les travaux d'Eudoxe de Cnide' (1841).

**EUPAULA**, ū-fā'la, Ala., city in Barbour County, on the Chattahoochee River, and on the Central of Georgia Railroad; 80 miles southeast of Montgomery. It is at the head of steamboat navigation on the river; is the trade centre of a large manufacturing and agricultural district, and carries on an extensive cotton-shipping trade, exporting over 30,000 bales annually. It has manufactures of cotton-goods, cottonseed oil, buggies and fertilizers. It has gas and electric lights, waterworks plant erected by the city in 1897 at a cost of \$60,000,

public parks, Union Female College, public high school and three national banks. Pop. 4,259.

**EUGANEAN** (ū-gā'nē-an) **HILLS**, a range of well-wooded hills, lying southwest of Padua, in northern Italy, between the river Bacchiglione, the canals of Battaglia and Este and the river Bisatto, deriving their name from an ancient Italian people called Euganei. They owe their origin to eruptions of trachyte during the Jurassic Period. The highest point, Monte Venda, reaches about 1,980 feet. On their slopes stand several villas with interesting histories, among them Petrarch's house at Arquà in which the Italian poet died in 1374. His tomb is on the market square of Este at the southern end of the Hills and near this town is the villa, I Cappuccini, lent by Byron to Shelley, who there finished the first part of 'Prometheus Unbound' and also wrote 'Lines Written Among the Euganean Hills' (1818). There are also a number of monasteries dating back to the early Middle Ages, some of them in ruins. Valuable building stone, quarries and mineral springs abound. Consult Reyer, E., 'Die Euganeen. Bau und Geschichte eines Vulkans' (Vienna 1877); Symonds, J. A., 'Among the Euganean Hills' (in *Fortnightly Review*, Vol. LIV, p. 107, London 1890).

**EUGANEL**. See EUGANEAN HILLS.

**EUGEN, Frederich Karl, DUKE OF WURTEMBERG**, Russian general: b. Oels, Germany, 1788; d. 1857. His aunt was the wife of Tsar Paul of Russia and while still in his early years he was made major-general. In 1806-07 he took part in the military operations in Prussia and in 1810 in Turkey. He won distinction at Borodino, Krasnoi, Lutxen, Kulm, Leipzig and other battles, commanded the Seventh Russian Army Corps in the war with Turkey in 1828 and retired from the service after the peace of Adrianople. He now gave his attention to study and composed an opera 'Die Geisterbraut,' produced at Breslau in 1830. His works include 'Erinnerungen aus dem Feldzuge des Jahres 1812 in Russland' (1846) and 'Memoiren' (1862).

**EUGEN ONIEGIN**, an opera in three acts by Peter Ilich Tschaiikowsky (libretto adapted from Poushkin), first performance by the students of the Conservatory at Moscow in March, 1879. The reception was cool, but gradually the work crept into popular favor. In spite of the strong dramatic character of Tschaiikowsky's music, he never developed any marked talent for the theatre and from the dramatic standpoint 'Eugen Oniegin' shows many weaknesses. Beside the works of the younger Russian school of which Monssorgsky is the leader, it seems to lack the virility that has come to be associated with modern Russian music. The influence of sunny Italy is felt rather than that of the Northern steppes. But the music breathes the composer's joy in creation and is pervaded by a romantic melancholy and elegiac sentiment that makes its emotional appeal very strong. The latter scene is the most popular bit in the opera. Rosa Newmarch, who has made a special study of Russian opera, likens 'Eugen Oniegin' to "the embodiment of some captivating, wayward, female spirit, which subjugates all emotional natures, against their reason, if not against their will." LEWIS M. ISAACS.

**EUGÈNE**, è-zhān, Prince (FRANÇOIS EUGÈNE DE SAVOIE-CARIGNAN), Austrian general: b. Paris, 18 Oct. 1663; d. Vienna, 21 April 1736. Among all the generals and statesmen of Austria, none has rendered more numerous and important services than Eugène. He was great alike in the field and the cabinet. He petitioned Louis XIV for a company of dragoons, but was refused on account of the opposition of Louvois, Minister of War, who hated the family of Eugène. Indignant at this repulse and at the banishment of his mother, a niece of Cardinal Mazarin, Eugène, in 1683, entered the Austrian service. The distinction he earned at the siege of Vienna in 1683, at that of Belgrade in 1688, at that of Mayence in 1689 and elsewhere, procured for him rapid promotion. War having broken out between France and Austria, he prevailed upon the Duke of Savoy to enter into an alliance with the emperor, and in 1690 received the command of the imperial forces sent to Piedmont to act in conjunction with the troops of the Duke of Savoy. He defeated the Turks at the battle of Zenta (11 Sept. 1697) and obtained on that occasion the applause of Europe. The loss of the Turks at Zenta obliged them to accede to the Peace of Carlowitz, 1699, which was the first symptom of their decline. On the outbreak of the War of the Spanish Succession he was given the command in Italy and defeated the French on several occasions, but inadequate forces led to his defeat at Luzzara, 15 Aug. 1702. In 1703 he received the command of the army in Germany, and his efficient co-operation with Marlborough frustrated the plans of France and her allies. In the battle of Höchstädt (Blenheim), 13 Aug. 1704, the two heroes gained a decisive victory over the French and Bavarian army, commanded by the Prince of Bavaria and Marshal Tallard, the latter of whom was made prisoner. In 1705 Eugène returned to Italy, where he hastened to the relief of Turin, stormed the French lines, forced them to raise the siege and in one month drove them out of Italy. In 1707 he entered France and laid siege to Toulon; but the immense superiority of the enemy obliged him to retire into Italy. During the following years he fought on the Rhine, took Lille and, in conjunction with Marlborough, defeated the French at Oudenarde (1708) and Malplaquet (1709). After the recall of Marlborough and the defection of England and Holland from the alliance against France, his farther progress was in a great measure checked. The Peace of Rastadt, the consequence of the Treaty of Utrecht, was concluded between Eugène and Villars in 1714. In the war with Turkey, in 1716, Eugène defeated two superior armies at Peterwardein and Temesvar, and, in 1717, took Belgrade, after having gained a decisive victory over a third army that came to its relief. The Treaty of Passarowitz (concluded in 1718) was the result of this success. His fame is still celebrated in popular song, "Prinz Eugen der edle Ritter." He was also distinguished as a discriminating patron of art and literature. Consult Malleison, 'Prince Eugène of Savoy (1888).

**EUGENE**, ù-jèn', Ore., city and county-seat of Lane County; on the Willamette River, the Southern Pacific, Oregon Electric and other railroads; 123 miles south of Portland and 50

miles from the Pacific Ocean. The University of Oregon was established here in 1876 and now has about 1,000 students. The city is also the seat of the Eugene Bible University and contains a Carnegie library. It is the commercial centre of a fertile agricultural region. Lumbering and gold and silver mining are carried on in the vicinity. The manufactures are chiefly flour, lumber, brick, tiling, fruit drying and packing, a flax factory and some articles for home consumption. The United States census of manufactures for 1914 showed within the city limits 37 industrial establishments of factory grade, employing 322 persons; 238 being wage-earners receiving annually a total of \$167,000 in wages. The capital invested aggregated \$651,000, and the year's output was valued at \$810,000: of this, \$403,000 was the value added by manufacture. The city was settled in 1854, and was incorporated in 1864. The government is administered by a mayor, chosen for two years, and a city council. The waterworks and electric-light plant are the property of the city. Pop. 12,000.

**EUGENE ARAM**, a novel by Edward Bulwer-Lytton (q.v.) written in 1831 and published in 3 vols., 1832. It was founded on the career of an English scholar, Eugene Aram: b. 1704; executed for the murder of one Clark in 1759. The character of the murderer and the circumstances of his life made the case one of the most interesting, from a psychological point of view, in the criminal annals of England. Aram was a scholar of unusual ability, who, self-taught, had acquired a considerable knowledge of languages, and was even credited with certain original discoveries in the domain of philology. Of a mild and refined disposition, his act of murder seemed a complete contradiction of all his habits and ideals of life. 'Eugene Aram' is an unusually successful study in fiction of a complex psychological case. At the time of its publication, it caused a great stir in England, many attacks being made upon it on the ground of its false morality. To the present generation its romance is of more interest perhaps than its psychology. Some years after the novel was first published, the author changed his opinion concerning the guilt of Aram and as a result also changed the story beginning with the edition of 1851. The English poet, Thomas Hood, wrote a poem on the same theme entitled 'The Dream of Eugene Aram' (London 1831). It has also been dramatized, first by Bulwer-Lytton, who, however, never finished the play but published it in its unfinished form in *The New Monthly Magazine and Literary Journal* (Vol. XXXVIII, p. 401, London 1833), and later attached it to the novel itself. Other dramatic versions were published by Moncrieff, W. T., 'Eugene Aram, or Saint Robert's Cave' (in 'French's Acting Edition of Plays,' Vol. CIII, London and New York, n. d.); Williams, E. W. H., 'Eugene Aram. A Play in Five Acts' (New Orleans 1874), and Wills, W. G., 'Eugene Aram' which was produced in 1873 by Henry Irving. For the history and life of Eugene Aram consult Scatcherd, N., 'Memoirs of Eugene Aram' (London 1838).

**EUGÈNE DE BEAUHARNAIS**, è-zhān dé bō-ār-nā. See BEAUHARNAIS, EUGÈNE DE.

**EUGENI ONYEGIN.** Pushkin's poem 'Eugeni Onyegin' is the prototype of the Russian novels dealing with unsuccessful heroes. Here the hero Onyegin represents a member of cultured society in the 20's who took Childe Harold for their example. Indeed, the first canto arose directly under the influence of Byron's 'Don Juan' and 'Childe Harold,' but in the further development Pushkin described, not an individual blasé, but a class type of helpless, frivolous upper society, and, to a certain extent, gave his poem the nature of a social satire, as which it was recognized by contemporary critics. But, although Pushkin in the beginning of his poem pursued Onyegin with banter and irony, he looked more objectively at the hero as he proceeded, and even pitied him, when his relation to Lenski and Tatyana became tragic. Onyegin began by joining in his friends' orgies, but soon commenced to pine, and at last tried to busy himself with affairs. He wanted to act as a benefactor to his peasants, but was not understood by them. After killing Lenski in a duel, he started on a journey, but even his wandering could not cure his blasé spirit. He insulted simple-minded, faithful Tatyana with his cold counsels, and fell in love with her only when he found her married to another man.

The enormous popularity of this poem is evidenced by the fact that up to 1885 it was reprinted in whole or in part 27 times, while for the same period there are recorded 55 critical essays dealing with the subject and 33 translations. English translations are by D. Minaieff, (Saint Petersburg 1868); by Mrs. J. Buchan Telfer (née Mouravieff, London 1880); by Spalding (London 1881). It was dramatized in 1846, and in this form was kept in the repertoire until 1852. It gained its greatest popularity through Chaykovski's opera, written in 1872.

LEO WIENER.

**EUGENICS** (from Greek *εὐγενής* well-born). According to Francis Galton, the great English scientist who, in 1883, first used the term "eugenics," this branch of learning "is the science which deals with all influences that improve the inborn qualities of a race." Within the scope of such influences Galton included all forces that tend to produce an increase in the number of such individuals as possess desirable hereditary qualities and a decrease in the number of those whose transmissible traits are undesirable. As applied to the human race Galton admitted that differences of opinion exist as to what hereditary traits are desirable and what are not. A warrior may approve pugnacity, a statesman, tolerance. An hereditary trait expressing itself in one of these qualities might easily prove unfavorable for the development of the other. Who, then, is to decide what qualities are really favorable? Galton met this difficulty by pointing out the fact that few persons would fail to consider desirable such fundamental qualities as health, energy and ability. In a lecture before the Sociological Society of London in 1904 he reviewed some of the results that in his opinion would follow if the British nation through the practice of eugenics were to raise its average quality to that of its better half. "The general tone of domestic, social and political life would be less foolish, less frivolous, less excitable and polit-

ically more provident than now. Its demagogues who 'Played to the gallery' would play to a more sensible gallery than at present. We should be better fitted to fulfil our vast imperial opportunities. Lastly men of an order of ability which is now very rare would become more frequent because the level out of which they rose would itself have risen." It is evident, from the foregoing, that knowledge of the laws of heredity is requisite if eugenics is to be scientific in fact as well as in aim. Such knowledge must necessarily include ability to tell not only what traits are transmissible by physiological processes but also the extent to which they are heritable. If these laws be given as known factors, the eugenist then becomes interested in discussing how they may be utilized. He wishes to know who are the bearers of the desirable hereditary traits and how they may be led to contribute a relatively large proportion of offspring to the succeeding generation. Likewise he wishes to know who are the bearers of undesirable hereditary traits and how their contributions may be minimized. Still further, having ascertained these facts he wishes by propagandist methods to spread abroad whatever knowledge exists within the field and by practical measures to better the breed of man.

The idea that, like the animals, the breed of man may be improved by a conscious selective process is by no means modern. It appears even in early Chinese literature. Plato's suggestions on this subject in the 'Republic' are too well known to dwell upon. Some of the Roman classical writers even give explicit rules of procedure. The modern eugenics movement, however, dates from the publication in 1865 of two articles on 'Hereditary Talent and Character' by Francis Galton in *Macmillan's Magazine* for that year. So far as its scientific foundation is concerned, the origin of eugenics may be considered identical with the beginnings of biology. For this no specific date can be assigned because the history of biology — as most excellently outlined by Prof. H. F. Osborne in 'From the Greeks to Darwin' — may be traced from a very early period. Nevertheless it was Darwin's 'Origin of Species' that in 1859 inaugurated the distinctly modern period of biological investigation. The rapid and widespread acceptance of Darwin's contention that the most fundamental characteristics of all living organisms are subject to change naturally prepared the public mind for a practical program for bettering those characteristics. Therefore when in 1869 under the title of 'Hereditary Genius,' Galton presented extensive biographical studies in support of the contention that great ability is hereditary his ideas received widespread attention. An increasing literature on this and other phases of the problem soon popularized the subject. Eminent English writers, such as Wallace, Greg and even Darwin himself took part in the movement. In 1873 the appearance of Alphonse de Candolle's 'Histoire des sciences et des savants' marked the beginning of the interest of continental investigators. In the same year appeared Ribot's 'L'Hérédité psychologique.' Later, Georg Hansen's 'Die drei Bevölkerungstufen,' Ammon's studies of an anthropological character and Lepouge's 'Les sélections sociales' raised the question whether the assumed Aryan race was not suffering from a "reversed selection"

caused by the attraction of the best stock to cities and a failure to reproduce therein. The subject matter of de Candolle's work was closely related to that of Galton's. The conclusions reached in the former's book, however, did not fully support Galton's belief that specialized ability is hereditary. Galton immediately replied to it in an effective manner and shortly after brought out his classic 'English Men of Science: their Nature and Nurture.' In this he set forth additional carefully compiled data indicating the supremacy of nature over nurture. Shortly after these hopeful beginnings popular interest in the field now known as eugenics waned in England and for more than two decades little attention was paid to the scientific side of the subject. It is true that during this period Galton produced two important works 'Inquiries into Human Faculty and its Development' and 'Natural Inheritance,' the first in 1883 and the second in 1889, but they aroused comparatively little general notice. Even Galton himself "laid the subject wholly to one side for many years."

In America, however, various contributions to the problem of race betterment appeared from time to time. Among these Mr. Robert L. Dugdale's 'The Jukes' (1877) was easily the most important. This was a thoroughly scientific and intensive study of a degenerate family. In it the characteristics of over 500 descendants of the head of the family were carefully recorded and a number of important "tentative" inductions were drawn. Among these were: pauperism preponderates in the consanguineous lines; crime preponderates in the illegitimate lines; illegitimate criminal lines show collateral branches which are honest and industrious. A popular impression has quite generally prevailed in America that this study of the Jukes constitutes a demonstration of "hereditary criminality," "hereditary pauperism," etc. This impression is unwarranted. As Professor Giddings has pointed out its author never made such a claim for it. "Mr. Dugdale," he says, "undoubtedly believed in the hereditary transmission of character tendencies as of physical traits and here and there he points out what seem to him to be evidences of heredity in this sense in the 'Jukes' blood. But he is ever careful to say 'seemingly' or 'apparently' or otherwise to warn the reader that the conclusion is tentative. Far from believing that heredity is fatal, Mr. Dugdale was profoundly convinced that 'environment' can be relied upon to modify and ultimately to eradicate even such deep-rooted and wide-spreading growths of vice and crime as the 'Jukes' group exemplified." Another study of similar nature by McCulloch was published somewhat later under the title the 'Tribe of Ishmael.' In 1883 Dr. Alexander Graham Bell's 'Memoir upon the Foundation of a Deaf Variety of the Human Race' appeared, and shortly after under the imprint of the Volta Bureau, endowed by Dr. Bell himself, there followed Dr. Fay's 'Marriages of the Deaf in America.' Somewhat later under the stimulus of Dr. Amos Warner's chapter on "Charity as a Factor in Human Selection" in his 'American Charities,' various studies on this topic were published in the annual volumes of the proceedings of the National Conference of Charities and Correction. These publications naturally appealed to a rather lim-

ited number of specialists. Popular interest in the specific eugenic problem of social improvement through better breeding was waning to some extent in America just as it was in England.

The beginning of the 20th century, however, witnessed a very marked reawakening. By that time Darwin's doctrine of selection had thoroughly established itself and the public was accustomed to think of biological laws as something more than mere hypotheses. By that time, also, the Italian school of criminologists including Lombroso, Garofalo and Ferri had aroused lively discussion of the question as to how far there was a true hereditary criminal type. In England much alarm had been occasioned by the military reverses in South Africa. Moreover at about the same period Charles Booth's thorough investigations had been revealing the wide extent of poverty and degradation in London. The discussion of Max Nordau's 'Degeneration' (1893) which had aroused widespread fears of progressive deterioration had not yet wholly died away and Benjamin Kidd's 'Social Evolution' (1894) which had emphasized the relation of religion and biology to social progress was still the subject of lively comment in pulpit and press. In view of this situation it is not strange that Karl Pearson, the foremost eugenicist of England, after Galton, created almost a sensation when in November 1900 he delivered his now famous Newcastle lecture on 'National Life from the Standpoint of Science.' In this lecture he reviewed what he regarded as sources of weakness in the British population and emphasized the necessity of being ever ready to meet the competition of other peoples. "If the nation," he said, "is to maintain its position in this struggle it must be fully provided with trained brains in every department of national activity. . . . Are we certain we have a reserve of brain-power ready to be trained? We have to remember that man is subject to the universal law of inheritance and that a dearth of capacity may arise if we recruit our society from the inferior and not the better stock." Again he exclaimed, "Our legislators get wonderfully excited over laws relating to horses and cattle; they devote money and time to breeding purposes and realize the strength of the law of inheritance when they endow national studs and give prizes to encourage the maintenance of good stock or when again they work for the establishment of selected herds. But which of them has considered domestic legislation from the national history standpoint? What statesman has remembered that in the character of the national fertility of to-day is written the strength or weakness of the nation to-morrow?" Primarily through the efforts of Professor Pearson, this lecture was followed a little later by the founding of the journal known as *Biometrika*. This journal became the particular organ of those eugenicists who attacked the problem from the mathematical and statistical point of view. The impetus given to the movement by the various investigations published in this journal, however, was greatly strengthened by developments following another striking event—also purely scientific in its nature—which had occurred unexpectedly in 1900. This was the rediscovery by several independent workers of the so-called Mendelian laws of

heredity. These laws had been announced by Gregor Mendel as early as 1868 but had received practically no attention. After their rediscovery, however, biologists all over the world began systematic experiments to ascertain the extent to which the so-called "laws" applied. Hitherto such "laws" of heredity as had been formulated always expressed a relationship between the average amount of a given trait in an entire group of ancestors and the average amount of the same trait in the entire group of their descendants. For example, the Galtonian "law of ancestral heredity" was, that two parents contribute together, on the average, one-half of the total heritage of the offspring; the four grandparents, one-quarter; the eight great grandparents, one-eighth. This, even if true, tells nothing about the probability of a given individual inheriting any given characteristic from any particular ancestor. The Mendelian laws, however, formulated relationships between specific traits of a single pair of ancestors and the corresponding traits in their descendants. For example, it happens that eye color in man appear to "mendelize." Thus to take a single specific instance it is held, with a high degree of probability, that if both parents have blue or gray eyes they cannot have children with black or brown eyes. The laws also express other equally definite but more complex relationships of a highly significant character. How many of the important heritable characteristics of man follow the Mendelian laws is not yet known. The problem is one susceptible of accurate investigation, however, and rapid strides are now being made in solving it. Some notion of the importance of the results likely to follow as further facts are collected may be gained by consideration of a single one out of many discoveries—namely, the operation of one phase of the law in the case of feeble-mindedness. This trait is said to behave like the blue color of eyes: that is, almost without exception, if both parents are feeble-minded none of the children will be normal. Dr. Henry H. Goddard, one of the foremost experts on feeble-mindedness in this country, found this to be true in the case of all but six of 482 children whose parents were all feeble-minded.

The importance for eugenics of the discovery of the Mendelian laws and of the farther investigation of the extent of their validity is evident. In the case of feeble-mindedness alone, the facts stated above, taken together with other known relationships of similar definiteness, constitute ample justification for active efforts to prevent propagation by the feeble-minded. This is not the place to present extended discussion of the technical phases of the biological side of the eugenic problem. Attention may properly be directed, however, to some of the hopes and anticipations, cherished by contemporary eugenicists, that will indicate the possibilities of improvement if, in fact, the biological basis of the claims becomes fully established. Dr. Charles Davenport, director of the department of experimental evolution of the Carnegie Institution at Cold Spring Harbor, Long Island, is, at the present time, one of the most enthusiastic believers in what the future holds in store for eugenics. In describing the plans for the work of the committee on eugenics of the American Breeders' Association he outlined a number of interesting plans for future advance. Accord-

ing to Dr. Davenport one sub-committee of that organization is charged with the study of the feeble-minded. "This committee," he says, "has most important interests since the number of feeble-minded in the United States alone is probably not less than 150,000 of which 15,000 are in institutions." Other contemplated types of work for the eugenic committee included study of the protoplasmic basis of eye defects; deafness, predisposition toward lung and throat trouble and toward diseases of the excretory and circulatory organs. Still other forms of investigation which Dr. Davenport hoped could be undertaken were studies of criminality and pauperism, the effects of consanguineous marriages and of "such mongrelization as is proceeding on a vast scale in this country." He was particularly anxious that the extant records of institutions be studied. The amount of such data is enormous. "They lie hidden in records of our numerous charity organizations, our 42 institutions for the feeble-minded, our 115 schools and homes for the deaf and blind, our 350 hospitals for the insane, our 1,200 refuge homes, our 1,300 prisons, our 1,500 hospitals and our 2,500 almshouses. Our great insurance companies and our college gymnasiums have tens of thousands of records of the characters of human blood lines." By study of these records it will be possible "to learn whence come our 300,000 insane and feeble-minded, our 160,000 blind or deaf, the 2,000,000 that are annually cared for by our hospitals and homes, our 80,000 prisoners and the thousands of criminals that are not in prison and our 100,000 paupers in almshouses and out. This three or four per cent of our population is a fearful drag on our civilization. . . . A new plague that rendered four per cent of our population, chiefly at the most productive age, not only incompetent but a burden costing \$100,000,000 yearly to support would instantly attract universal attention and millions would be forthcoming for its study as they have been for the study of cancer. But we have become so used to crime, disease and degeneracy that we take them as necessary evils. That they were, in the world's ignorance is granted. That they must remain so, is denied. . . . Vastly more effective than ten million dollars to 'Charity' would be ten millions to eugenics. He who by such a gift should redeem mankind from vice, imbecility and suffering would be the world's wisest philanthropist." A considerable part of the actual investigations outlined by Professor Davenport has been undertaken under his own direction at Cold Spring Harbor and the results have been published from time to time in the bulletins of Eugenics Record Office.

The phases of eugenics emphasized by Professor Davenport in the foregoing account are chiefly negative. They have to do with efforts to eliminate the unfit. Positive eugenics deals with a wholly different field, namely, the effort to increase the productivity of the best stocks. There is no doubt whatever that the birth rate among the more highly educated classes throughout the civilized world tends to be much lower than that of the more ignorant classes. It is true that a corresponding state of affairs exists in the matter of death rates. In spite of this, however, the actual effective contribution of the better educated to the next generation is at a much lower rate than that of the ignorant.

Not only is it true that college graduates as a group are scarcely reproducing themselves but the same is true of the foremost men of science. The completed family of the contemporary scientific man in the United States and Canada according to a very careful investigation by Professor Cattell is about two; the surviving family about one and eight-tenths. Twenty-two per cent of the families are childless; only one family in 75 is larger than six. As a rule the native-born inhabitants of Massachusetts rank fairly high as regards education. During the 25 years from 1887 to 1911 the deaths among this class exceeded births in families where the parents were native born by 269,918. The eugenic importance of these declines in birth rates among educated persons depends entirely upon the question whether, as a matter of fact, the better educated are, on the average, possessed of better hereditary characteristics than other classes. Biologically considered the training that a man receives cannot be held to increase in any way the probability of his having children of higher talent than if he had not had any training whatsoever. It may well be, however, that, on the average, those who possess better hereditary traits have succeeded in obtaining a good education more frequently than have persons less well endowed by nature. On the other hand it may well be that, on the average, educated and successful persons have merely been more fortunate than others. The question as to whether or not success is an evidence of hereditary superiority has been long debated but is yet far from solution. Galton believed that if the eminent men of any period had been changelings when babies a very fair proportion of those who survived and retained their health up to 50 years of age would, notwithstanding their altered circumstances, have equally risen to eminence. If a man is gifted with vast intellectual ability, eagerness to work and power of working, Galton could not comprehend how such a man could be repressed. If this belief proves to correspond with fact, it is easy to see that the more successful members of society, including the better educated, must be the carriers of hereditary traits higher than the average. A low birth rate in such classes would be correspondingly serious from the eugenic point of view. It is, however, very doubtful if the argument can legitimately be pushed as far as Galton carried it. Prof. Lester F. Ward was never weary of contending that natural ability is distributed fairly evenly throughout the various classes in society. Naturally he did not contend that all individuals are equally endowed at birth—such a contention would have been absurd. He did hold, however, that in all probability the percentage of individuals highly endowed by nature with desirable hereditary qualities in all nations and in all social classes does not materially differ. If the question here presented could be scientifically solved it would carry with it the solution of the vexed question as to whether some races are by nature superior to others. Galton was consistent in holding that the ancient Greeks were much more highly endowed with desirable hereditary qualities than are modern Europeans, and that the African negro of to-day ranks about as far below the present European as the ancient Greeks ranked above. The anthropol-

ogist Boas on the other hand agrees with the "egalitarian" view held by Ward.

Because of the differences of opinion held concerning many of the biological questions involved it is evident that no careful thinker is likely to give unqualified approval to the more extreme practical measures advocated by radical eugenicists. It is probably in part at least for this reason that advocates of the "sterilization of the unfit" have not as yet succeeded very fully in having their ideas carried over into legislation. It is true that 12 commonwealths of the United States have enacted sterilization laws, but only two appear to have attempted any enforcement and only a few operations have actually been performed. On the other hand the increasing adoption of the idea that custodial care is necessary for the feeble-minded reflects the increasing willingness of public authorities to carry out measures advocated by those more moderate eugenicists who base their practical plans upon established biological facts.

Possibly the most hopeful fact in the field of eugenics at the present time is the growing interest in the subject itself and the increasing number of trained investigators who are at work upon the various phases of the problems which lie within the field. One has only to glance over the reviews of books and articles on eugenic topics commented on or listed in the *Eugenics Review* to be convinced of the tremendous popular literature that is accumulating. On the other hand one needs but to scan a few of the numerous strictly scientific journals in the field of biology to realize what a vast amount of accurate research is going on within the general field of heredity. To be convinced that much valuable work in the specialized investigation of strictly eugenic problems is being done one need but turn to publications embodying from time to time the results reached at the biometric and eugenic laboratories in England and, in America, the bulletin of the Eugenics Record Office. The work of this American office according to its own prospectus is: (1) To serve eugenic interests in the capacity of repository and clearing house. (2) To build up an analytical index of the traits of American families. (3) To train field workers to gather data of eugenic import. (4) To maintain a field force actually engaged in gathering such data. (5) To co-operate with other institutions and with persons concerned with eugenic study. (6) To investigate the manner of inheritance of specific human traits. (7) To advise concerning the eugenic fitness of proposed marriages. (8) To publish results of researches. To such persons as will undertake to fill them out it furnishes free in duplicate (one copy to be retained by the applicant) the following blank schedules: (1) Record of Family Traits; (2) Index to Germ-plasm—a Parallel Family Record of Prospective Marriage Mates; (3) Musical Talent; (4) Mathematical Talent; (5) Tuberculosis; (6) Special Trait Chart; (7) Hare-lip and Cleft-palate.

The foregoing is sufficient evidence that the modern eugenic movement is very much alive. To what extent it will suffer from the present war is difficult to predict. Undoubtedly it will lose the services of many brilliant minds that, had peace continued, would have made notable contributions to the subject. It will thus, with



Courtesy of the Booklovers Magazine

**EUGENIE**

From the painting by Winterhalter





all the other sciences, feel the "disgenic" effect of war. On the other hand the various psychological investigations now being attempted on a very large scale with army men as subjects may throw such light on various phases of the eugenic problem that the science will advance even more rapidly than it has in the past. Furthermore the war may itself produce such potent demonstrations of various contentions now merely debated that the net result for the science, if not for the race, will be advantageous. Consult BIOLOGY; HEREDITY; MENTAL TESTS; STERILIZATION.

**Bibliography.**—Galton, Francis, 'Hereditary Genius' (London 1869); id., 'Natural Inheritance' (New York 1889); id., 'English Men of Science: Their Nature and Nurture' (New York 1895); id., 'Inquiries into Human Faculty and Its Development' (New York 1883); Pearson, Karl, 'National Life From the Standpoint of Science' (London 1901); Conklin, E. G., 'Heredity and Environment in the Development of Men' (Princeton 1916); Davenport, C. B., 'Heredity in Relation to Eugenics' (New York 1911); Dugdale, R. L., 'The Jukes' (4th ed., New York 1910); Goddard, H. H., 'Feeble-mindedness' (New York 1914); id., 'The Kallikak Family' (New York 1912); Castle, Wm. E.; Coulter, J. M.; Davenport, C. B.; East, E. M.; Tower, W. L., 'Heredity and Eugenics' (Chicago 1912); Doncaster, L., 'Heredity in the Light of Recent Research' (Cambridge, England 1911); Guyer, M. F., 'Being Well Born' (Indianapolis 1916); Tenney, A. A., 'Social Democracy and Population' (in Columbia University Studies in History, Economics and Public Law, Vol. XXVI, No. 4, New York 1907); Kellicott, W. E., 'The Social Direction of Human Evolution' (New York 1911); 'Eugenics Laboratory Memoirs' (London 1901- ); 'Record Office Memoirs' (Cold Spring Harbor, N. Y., 1912- ).

Journals: *Biometrika* (London 1902- ); *The Eugenics Review* (published by Eugenics Education Society, London 1909- ); *Archiv für Rassen- und Gesellschafts Biologie* (Berlin 1904- ); *The Journal of Heredity* (Washington, D. C., 1910).

ALVAN A. TENNEY,  
Assistant Professor of Sociology, Columbia University.

**EUGÉNIE**, è-zhâ-nê (EUGÉNIE MARIE DE MONTIJO DE GUZMAN Y DE PORTO-CARRERO), empress of the French: b. Granada, Spain, 5 May 1826. Her father, the Count de Montijo, was of a noble Spanish family; her mother was of Scotch extraction, maiden name Kirkpatrick. On 29 Jan. 1853 she became the wife of Napoleon III and empress of the French. On 16 March 1856, a son was born of the marriage. When the war broke out with Germany she was appointed regent (27 July 1870) during the absence of the emperor, but on 4 September the revolution forced her to flee from France. She went to England, where she was joined by the prince imperial and afterward by the emperor. Camden House, Chiselhurst, became the residence of the imperial exiles. On 9 Jan. 1873, the emperor died, and six years later the prince imperial was slain while with the English army in the Zulu war. In 1881 the empress transferred her residence to Farnbor-

ough in Hampshire. She has published 'Some Recollections from My Life' (1885).

**EUGÉNIE GRANDET**, è-zhâ-nê grôn-dâ. In the scenes of the 'Comédie Humaine' that present aspects of provincial life the first place by universal assent belongs to 'Eugénie Grandet' (1833). Its heroine is Balzac's finest female character, radiant in the generosity of her love; its story is probably the most terrible study of the corroding influence of avarice in any literature. Its astonishing power of gradually developing description, exhibited in the account of Old Grandet's house, its strong-room, store-closet, stairway, gives a presiding personality to inanimate objects in which each detail marks the inevitable next step in the inexorable progress of the miser's vice to monomania. Grandet's assumed stammering hesitancy in bargaining infects the reader with the same impatience that it was designed to produce in his victims in negotiation. "There was in him," says Balzac, "something of the tiger, something too of the boa-constrictor. He could lie in wait, watch his prey, leap on it,— and then, opening the jaws of his purse, he would swallow a pile of *écus* and settle down tranquilly, like the serpent after his meal, impassive, cold, methodical."

The story in brief outline is this: Félix Grandet, a cooper of Saumur, has amassed wealth from trade, land speculation and usury, but with such shrewd concealment that his wife and his daughter Eugénie think him as straitened as he is penurious. Partial confidants of his business intrigue for the hand of the unsuspecting heiress, but are made the dupes and tools of Félix to swell his own fortune. Charles Grandet, a Parisian cousin, son of a bankrupt suicide, wins Eugénie's sympathy and a love of which he proves unworthy. Félix contrives to save his brother's name to his own hidden profit. Eugénie remains faithful to the memory of Charles, who prospers in India, while Félix, with unrelaxing vigilance, is ever seizing and devising new ways to add to his hoard. Eugénie had given Charles her little store of gold coins on his departure. Her father sees opportunity to increase it by exchange. His discovery of the gift leads to a terrible scene, accentuating the miser's mania. He confines Eugénie and ignores her; avoids his wife, who falls ill. Should she die he would have to render an account of her estate to his daughter. It becomes policy to keep the ailing wife alive and to cajole Eugénie to a renunciation of the accounting. The mother dies, but Eugénie's renunciation even of the inheritance from her is attained with a truly diabolical ingenuity by playing on the poor girl's emotions. Five years later Félix dies, clutching at the gold on a crucifix. His last words to his daughter, in the very gasp of death: "Be careful. Some day you will have to render an account of all." Eugénie, now a woman of 30 and heiress to 19,000,000 francs, looks over-sea for Charles. He returns with enough to marry for social position and, ignorant of Eugénie's fortune, writes her a shameful letter, enclosing a check for her loan, "with interest." He refuses to make final settlement of his father's debts. Eugénie does it. Charles discovers his mistake, too late. Eugénie contracts a marriage of form with the least unworthy of her old

suitors, a lawyer, who, thinking to secure her fortune, arranged that each should be the other's heir but was himself first to die.

No novel of Balzac's is better constructed, none has more scenes and descriptions that cling to memory. Grandet's business transactions are told with the keenest psychological insight. The leading characters are among the masterpieces of all fiction; the minor personages, especially the maid-servant, Nanon, are clearly defined. There are many scenes of great power; that of the miser's death is incomparable. Consult translation by Marriage, E., in 'Everyman's library.'

BENJAMIN W. WELLS,  
*Author of 'Modern French Literature.'*

**EUGENIUS**, ū-jā'nī-ūs, the name of four popes. The first, Saint Eugenius, was elected 654; d. 657. **EUGENIUS II** occupied the Roman See from 824 to 827. His election was contested by a powerful faction in the city who favored Cincinnus (Zinzinnus); and Lothaire, son of Louis le Débonnaire, who shared the empire with his father, came to Rome to quell the disturbance. On this occasion the people and clergy of Rome took the oath of fidelity to the two emperors and promised that thereafter whenever a new pope succeeded he should, before his consecration, take oath in presence of the people and the emperor's representative to honor the emperor as the protector of the Church. The Pope was the first to take this oath; its terms were complied with at the two papal elections next following, for example, of Valentinus who filled the see three months and of Gregory IV. **EUGENIUS III**: b. Pisa; d. Tivoli, 7 June 1153. He was a Cistercian abbot and a close friend of Saint Bernard of Clairvaux and was elected 1145. Before his consecration the populace of Rome, led by Arnold of Brescia, effected a revolution and overturned the papal government; during a reign of a little more than eight years Eugenius was most of the time in exile, living at Viterbo, Siena and other places in Italy and in France. **EUGENIUS IV**: b. Venice 1383; d. Rome, 23 Feb. 1447. He was a Celestine monk, cardinal and bishop of Siena when he was elected successor to Martin V 1431. On 23 July 1431 was opened the Council of Basel, convoked by his predecessor; but not one bishop was present for the opening, only theologians, abbots and canons. On 12 November the Pope ordered the council to be dissolved and convoked another council to be held in 1433 at Bologna; but the fathers of the council of Basel continued to hold their sessions; throughout his reign the Pope was in conflict with the council. From first to last the council sought primarily and almost exclusively to curb the authority of the Roman See, and in consequence there passed between Rome and Basel a succession of bulls ordering the dissolution of the council, annulling its acts, anathematizing its members; and from the other side decrees of the council declaring that general assembly of the Church to be superior in authority to the Pope, and finally a decree proclaiming Eugenius deposed and setting up as Pope, Amedeo, Duke of Savoy, who assumed the style Felix V. This was the act of the council in its 35th session held 8 July 1439. At the same date there was assembled at Florence, at the call of Eugenius, a council attended by

160 Latin and some 20 Greek bishops, with the Emperor John Palæologus; at this council a reconciliation was effected between the Eastern and Western churches; but it stood only till its terms and conditions became known in the East, when it was repudiated by the Greek Church. The cause of the rival Pope Felix was at this time fatally weakened by the withdrawal by the emperor Sigismund of his support and by his declaring for Eugenius.

**EUGIPPIUS**, or **EUGYPIIUS**, an Italian monk of the 5th century, born at Carthage. He studied at Rome and later became the pupil of Saint Severin at Fariana and was afterward abbot of Lucullanum, near Naples. In 511 he wrote 'Vita Sancti Severini,' but his most important contribution to ecclesiastical history is a collection of excerpts from the works of Saint Augustine, 'Thesaurus Augustianus.' Consult 'Corpus Scriptorum Ecclesiasticorum Latinorum' (Vol. IX, Vienna 1885-86).

**EUGNATHUS**, ūg-nā'thūs, a fossil fish, a precursor of the mudfish, found in the Liassic rocks of England and also in Bavaria. It possessed an elongated body with ganoid scales, supported internally by vertical ribs, some of which were joined to each other. It had dorsal, pelvic, pectoral, anal and tail fins.

**EUGUBINE** (ū'gū-bin) **TABLES**, the name given to seven bronze tables found in 1444 at the town of Gubbio, the ancient Iguvium or Eugubium, now in the Italian province of Perugia, bearing inscriptions in a language decided to be that of the ancient Umbrians. They were purchased by the town and are kept in its town hall. These tables are the most important monument of the language in which they are written. Four are inscribed in Umbrian characters, two in Latin and the remaining one partly in Umbrian and partly in Latin. The contents of the tables refer to the ritual customs of the ancient Iguvinians. Photographic reproductions of the inscriptions, with French translations, are given in Bréal, M. J. A., 'Les Tables Eugubines' (Paris 1875-78). An edition of the Umbrian text with interlinear Latin translation was published by F. W. Newman, 'The Text of the Iguvine Inscriptions' (London 1864). Consult Aufrecht, S. T., and Kirchhoff, J. W. H., 'Die Umbrischen Sprachdenkmäler, etc.' (2 vols., Berlin 1849-51); Bücheler, F., 'Umbrica' (Bonn 1883); Buck, C. D., 'A Grammar of Oscan and Umbrian' (Boston 1904); Conway, R. S., 'The Italic Dialects' (2 vols., Cambridge 1897); Huschke, G. P. E., 'Die Iguvinischen Tafeln, etc.' (Leipzig 1859); Lassen, C., 'Beiträge zur Deutung der Eugubinischen Tafeln' (Bonn 1833); Lepsius, K. R., 'De Tabulis Sugubinis' (Berlin 1833); id., 'Inscriptiones Umbricæ et Oscæ, etc.' (Leipzig 1841); Planta, R. von, 'Grammatik der Oskisch-Umbrischen Dialekte' (2 vols., Strassburg 1892-97).

**EUGUVIUM**. See GUBBIO.

**EUHEMERISM**, ū-hē'mē rīz̄m, or **EUEMERISM**. See MYTHOLOGY.

**EUKAIRITE**, ū-kā'rit, a rare mineral of a shining lead-gray color and granular structure, consisting chiefly of selenium, copper and silver  $Cu_2Se.Ag_2Se$ . Its name is derived from the Greek word meaning *opportune*, and was given to it by Berzelius because found soon

after the discovery of selenium. It occurs in Småland, Sweden, and in Chile and the Argentine Republic. Its hardness is 2.5 and its specific gravity 7.5. Consult Dana, E. S., ed. 'The System of Mineralogy of James D. Dana' (6th ed., New York 1914).

**EULACHON**, ū'lā-kōn, or **CANDLE-FISH**. See **CANDLE-FISH**.

**EULALIA**, ū-lā'li-a, Spanish virgin martyr: b. Merida, Estremadura; d. 12 Feb. 303 A.D. There is some doubt whether there was only one or more martyrs of this name. At any rate there are two distinct festivals celebrated in Spain, one at Barcelona on 12 February and one at Merida, 10 December. The legends, hymns and acts about these two saints are very similar in many points. Concerning Saint Eulalia of Merida it is reported that when she was only 12 years old, the great persecution of Diocletian was set on foot, whereupon the young girl left her maternal home and, in the presence of the Roman judge, cast down the idols he had set up. She was martyred by torture. Aurelius Rudentius has written (about 406) a hymn about the martyrdom of Saint Eulalia of Merida, of which there are a number of translations. Her relics are at Oviedo, whereas those of Saint Eulalia of Barcelona are preserved in the Barcelona Cathedral. The latter saint is the patron saint of Barcelona and of sailors. The oldest French poem in existence is also devoted to the description of the life and martyrdom of a virgin Saint Eulalia; but it is a mooted question whether it refers to one of the two Spanish saints or to still another. This manuscript is to be found in the library at Valenciennes. Consult Anon., 'Annals of Virgin Saints' (London 1846); Baring-Gould, S., 'The Lives of the Saints' (Vols II and XV, Edinburgh 1872); Moretus, H., 'Les Saintes Eulalies' (in *Revue des Questions Historiques*, Vol. LXXXIX, p. 85, Paris 1911); Runnart, T., 'Acta Primorum Martyrum, etc.' (Amsterdam 1713); Suchier, H., 'Über Inhalt und Quelle des ältesten Französischen Gedichtes' (in *Zeitschrift für Romanische Philologie*, Vol. X, p. 24, Halle 1891).

**EULALIA**, a popular name for certain species of tall perennial ornamental grasses of the genus *Miscanthus* (family *Poaceæ*). They are natives of eastern and southern Asia. The best-known species is probably *M. sinensis*, which has developed several well-marked horticultural varieties characterized by green, mottled or striped foliage and large terminal fan-like panicles of flowers, which, after shedding their deciduous parts, are still attractive because of their persistent silky hairs, which give the panicle a delicate, fluffy appearance for which they are valued as house decorations and for everlasting bouquets. Because of their beauty, their perfect hardiness and the ease with which they can be propagated by means of seeds or division of the roots, these plants are universal favorites, especially for bedding purposes.

**EULALIUS**, an antipope, elected in opposition to Boniface I in 418. His election is the first instance of the interference of the temporal authorities in a papal election. Eulalius was unable to maintain his authority against

Boniface and was forced to leave Rome. Soon afterward he resigned his pretensions and submitted.

**EULENBURG**, o'flēn-bērk, Hermann, German physician: b. Muhlheim-on-the-Rhine, 1814; d. 1902. He was educated at the universities of Bonn and Berlin. From 1860 to 1870 he was government medical counsellor at Cologne and in the latter year was named counsellor to the Ministry of Education, in which relation he remained until 1887. In Coblenz he founded the *Korrespondenzblatt der deutschen Gesellschaft für Psychiatrie und gerichtliche Medizin* and from 1870 to 1890 was editor of *Vierteljahrsschrift für gerichtliche Medizin und öffentliches Sanitätswesen*. He published 'Das Medizin-alwesen in Preussen' (1874); *Handbuch der Gewerbehygiene* (1876); 'Handbuch des öffentlichen Gesundheitswesens' (1882); 'Schul-gesundheitslehre,' with Bach (2d ed., 1896).

**EULENBURG**, Philip, PRINCE: b. Königs-berg, Prussia, 1847. He took part in the wars waged by his country against Austria and France and later studied law at the universities of Leipzig and Strassburg. From 1888 to 1890 he was Ambassador at Oldenburg, latter at Stuttgart and Munich, and from 1894 to 1902 he served as Prussian Ambassador at Vienna. Ill health compelled his retirement and in 1900 he was raised in rank, being made Fürst in that year and having Hertefeld added to his title. He was also made hereditary member of the house of peers. Maximilian Harden attacked him bitterly in the *Zukunft* in 1907 and Eulen-berg's reputation suffered greatly in consequence and his influence was diminished. He wrote 'Rosenlieder' (1886; many later editions); 'Skaldengesänge' (1892); 'Dichtungen' (1892); 'Erich und Erika und andere Erzählungen für Kinder' (1893); 'Abenderzalungen, Märchen und Traume' (1894).

**EULENBURG**, o'flēn-boorg, Albert, Ger-man physician: b. Berlin, 1840. He received his education at Bonn and Berlin, was made assistant at the University Hospital, Greifswald in 1863 and there published 'Die hypodermatische Injection der Arzneimittel,' for which he was awarded a prize by the Hufeland Society, Berlin. He was named professor of therapeutics and director of the Pharmacological Institute at Greifswald in 1874, removed to Berlin in 1882 and began his researches in neuropathology, in which he was soon recognized as the leading authority. His published volumes include 'Sexuale Neuropathie' (1895); 'Lehrbuch der Nervenkrankheiten' (2d ed., 1878). He edited the 'Real-Encyclopädie der gesamten Heilkunde' after 1893, and with Schwabe the *Deutsche medizinische Wochen-schrift*.

**EULENBURG**, Botho, COUNT, German statesman: b. 31 July 1831. In 1867 he was elected to the North German Reichstag as a Conservative; became Minister of the Interior in 1878 and as such formulated the famous Socialist law of October 1878. Differences with Bismarck led to his resignation of this office 1881. In 1892 he succeeded Count Caprivi as president of the Prussian ministry, but owing to controversies between Eulenburg and Caprivi over the bill for an amendment to the criminal

code, the emperor dismissed them both in October 1894. In 1899 Eulenburg took his seat in the Herrenhaus, or Prussian House of Lords.

**EULENSPIEGEL**, oīlën-spe-gel, a typical character associated in Germany with all sorts of frolics and fooling. The type originated in Till or Tyll Eulenspiegel, a German clown who lived probably in the first half of the 14th century, and became celebrated for the wild pranks and escapades that he practised in all parts of Germany, and in some of the neighboring countries. According to popular account he was born at the village of Kneitlingen, near Brunswick, and died at Mölln, near Lübeck about 1350 where his tombstone with the design of an owl and a mirror on it may still be seen. The tricks and frolics currently attributed to Eulenspiegel first appear in a Low Saxon account written in 1483; the earliest edition, in High German, was published at Strassburg in 1515, a reprint of which was published in Halle (1885). A poetic treatment of the same theme was published by Johann Fischart (q.v.) as 'Der Eulenspiegel Reimensweiss' (Frankfort A. M. 1572; reprinted in Kürchner, J., 'Deutsche National-Litteratur,' Vol. XVIII, pt. 2, Stuttgart 1892). The same collection published a reprint of the prose version in Vol. XXV. The work became very popular, and was translated into nearly every European language. In English it first appeared as a miracle-play, with the title 'A Merry Feast of a Man that was called Howleglas' (Eulenspiegel meaning literally 'owl-glass'). An edition of Murner's collection was published by J. M. Lappenberg at Leipzig in 1854, and by K. Simrock at Frankfort A. M. in 1864; English translations and editions appeared in 1860 and 1890. In modern times a number of writers have used the same theme. Some of them drawing freely on the old source, but all of them creating more or less original results. Amongst these may be mentioned the work of the Dutch novelist, Charles de Coster, 'Tyll Ulenspiegel' (1867, transl. into German by F. v. Oppelu-Bronikowski, Jena 1911); that of the German poet, Julius Wolff, 'Till Eulenspiegel Redivivus, Ein Schelmenlied' (1875); and finally the musical rendition of the theme in form of a Rondo by Richard Strauss, 'Till Eulenspiegel's Merry Pranks' (1894). Consult, besides any standard 'History of German Literature,' Brie, F. W. D., 'Eulenspiegel in England' (in *Palæstra*, Vol. XXVII, Berlin 1903).

**EULER**, oi-lër, Leonard, Swiss mathematician: b. Basel, 4 or 5 April 1707; d. Saint Petersburg, 7 Sept. 1783. He was educated by his father, a minister and mathematician, and then studied at the University of Basel under the famous mathematician, Jacob Bernoulli, where he received the degree of Master in 1723. In his 19th year he gained the *accessit* of the prize offered by the Paris Academy of Sciences for the best treatise on the masting of vessels. He went to Russia in 1727 to become a member of the faculty of the newly founded Academy of Sciences of Saint Petersburg and, in 1733, became its professor of mathematics, where he labored with astonishing industry. He composed more than half of the treatises in this branch of science contained in the 46 quarto volumes published by the Saint Petersburg Academy 1727-83; and at his death left about 200 unpublished dissertations, subsequently

printed by the society. In 1741 he accepted an invitation from Frederick the Great to become professor of mathematics in the Berlin Academy, but in 1766 returned to Saint Petersburg. Soon after his arrival he was attacked by a very serious illness from which he finally recovered, but only after he had lost his eyesight. This, however, did not prevent him from continuing his work, employing a secretary and overcoming the difficulties in connection with his elaborate computations chiefly by means of his remarkable memory. He finally submitted to an operation which, at first, was successful; but in some way he suffered a relapse and lost his newly recovered sight again. He first gave the example of those long processes in which the conditions of the problem are first expressed by algebraic symbols, and then pure calculation resolves all the difficulties. He applied the analytic method to mechanics, and enlarged the boundaries of this science. He greatly improved the integral and differential calculus, of which he afterward published a complete course, which surpassed everything then extant on this subject. An extensive optical treatise, 'Sur la Perfection des Verres object. des Lunettes,' in the *Mémoires de Berlin* (1747), was the result of his inquiries into the means of improving spectacles. The share which he contributed by this work toward the discovery of achromatic telescopes is sufficient to distinguish his name in this department also. He also employed himself in metaphysical and philosophical speculations. He attempted to prove the immateriality of the soul, and to defend revelation against freethinkers. In his well-known 'Lettres à une Princesse d'Allemagne, sur Divers Sujets de Physique et de Philosophie' (3 vols., Saint Petersburg 1768-72), he attacks the Leibnitzian system of monads and pre-established harmony. Among his numerous writings may be mentioned here his 'Theoria Motuum Planetarum et Cometarum' (Berlin 1744); 'Introductio in Analysis Infinitorum' (2 vols., Lausanne 1748), which has always been regarded as his greatest production; 'Institutiones Calculi Differentialis' (Saint Petersburg 1755); 'Institutiones Calculi Integralis' (3 vols., Saint Petersburg 1768-70); 'Introduction to Algebra' (Saint Petersburg 1770); his 'Dioptrica' (3 vols., Saint Petersburg 1767-71); 'Opuscula Analytica' (2 vols., Saint Petersburg 1783-85). His industry was as remarkable as his genius. During his life of 76 years, of which about 60 were devoted to scientific studies, he published a total of 32 separately printed books written in Latin, German and French, and many running to more than one volume; 331 treatises in the publications of the Saint Petersburg Academy, all in Latin; 14 treatises for the Royal Academy at Paris, in French; 128 treatises for the Royal Academy at Berlin, all in French; and 196 miscellaneous treatises in Latin. For a detailed bibliography of his works consult Hagen, J. G., 'Index Operum Leonardi Euleri' (Berlin 1896). For his life, etc., consult Fuss, N., (Éloge de M. Leon. Euler' (Saint Petersburg 1783, Basel 1786); Hoppe, E., 'Die Philosophie L. Eulers' (Gotha 1904); Schulz-Euler, S., 'Leonard Euler' (Frankfurt a. M. 1907); Rudio, F., 'Die Baseler Mathematiker D. Bernoulli und L. Euler' (Basel 1884); id., 'L. Euler' (Basel 1884).

**EUMÆUS**, a character in Homer's 'Odyssey,' Book XV, who recognizes Odysseus on the latter's return from his long absence and who materially assisted the latter in getting rid of Penelope's suitors. He was a swineherd by occupation.

**EUMENES**, ū'mé-néz, Macedonian officer of Alexander the Great: b. Cardia, Thracian Chersonesus, 360; d. 316 B.C. He began his career as secretary to Philip, and after the latter's death occupied a similar post under Alexander, who also placed him in command of the cavalry. After the death of Alexander he was made governor of Cappadocia, Paphlagonia, and the coast along the Euxine as far as Trapezus. In 321 he, with Perdiccas, defeated Antipater, Craterus and Neoptolemus, but in 320 he was himself routed by Antigonus, and forced to retreat to Nora. Here he held out for over a year until his soldiers at last betrayed him into the hands of Antigonus, who had him executed in 316 B.C. Consult the lives by Nepos and Plutarch, also Vezin, 'Eumenes von Kardia: ein Beitrag, zur Geschichte der Diadochenzeit' (Münster 1907).

**EUMENES II**, king of Pergamum: d. 159 B.C. He was a son of Attalus I and succeeded to the throne in 197 B.C. He was a faithful ally of Rome, and for his services against Antiochus was given the provinces of Lydia, Mysia and Phrygia. He was also an able civil administrator and under him the kingdom was great and powerful, also rich and prosperous, and having Rome for an ally it was practically invincible in the East. Eumenes did much as a patron of art and science. He founded a magnificent library which in its day had no rival other than that of Alexandria.

**EUMENIDES**, ū-mén'ī-déz. See FURIES.

**EUMENIUS**, Roman educator: b. Augustodunum (Autun), in Gallia Lugdunensis, 260; d. 311 A.D. He became secretary to Constantius Chlorus, whom he accompanied on his campaigns. Constantius commissioned him to restore the famous schools of Augustodunum in 296. We have an address, 'Pro Restaurandis Scholis,' made there by him in 297. For other addresses attributed to Eumenius consult Baehrens, 'Panygerici Latini' (Leipzig 1874) and Teuffel, 'Geschichte der römischen Litteratur' (Vol. III, 6th ed., ib. 1913).

**EUMOLPIDÆ**. See EUMOLPUS.

**EUMOLPUS**, a mythical personage of ancient times, celebrated as a poet, warrior, hierophant and legislator, according to the common tradition a Thracian, the son of Poseidon and Chione, the daughter of Boreas. He is said to have been driven from Thrace, but to have afterward returned. The accounts of his subsequent career vary. According to one tradition he was the founder of the Eleusinian mysteries (q.v.), in which he was instructed by Demeter. The sacerdotal family of the Eumolpides at Athens claimed to be descended from this Eumolpus.

**EUMYCETES**, ū'mī-sé'téz, the name used to distinguish Ascomycetes and Basidiomycetes from the Phycmycetes. See FUNGI.

**EUNAPIUS**, Greek philosopher of the 4th century A.D. He was a native of Sardis and throughout his life bitterly opposed Chris-

tianity. In 366 he set up a Neoplatonist school at Sardis. He wrote 'Lives of the Philosophers and the Sophists.' This work was edited by Boissonade (Paris 1849). He also wrote a history of his own time of which only fragments have come down to us. These are to be found in Müller, 'Fragmenta Historicorum Græcorum' (5 vols., Paris 1841-73).

**EUNICE**, a Jewess of Lystra, mentioned in Acts xvi, 1; 2 Tim. i, 5; iii, 15. See TIMOTHY.

**EUNOMIANS**, the extreme faction of the Arian sect in the 4th century, so called from the name of their leader, Eunomius (q.v.). They asserted the doctrine that Jesus Christ the son of God is of different nature (or substance) from the Father (*ἀνόμιος καὶ ὁμοίαν καὶ κατὰ πάντα*: unlike in substance and everything): thus his doctrine was that of Unitarianism. The doctrine of the Roman Catholic Church, declared in the Council of Niceæ, was that of *ὁμοούσιος* consubstantiality; that of the Semi-Arians was that the Son is of like or similar substance, *ὁμοιοούσιος* and hence they are called *homœusians*, while the orthodox took the name of *homousians* (both words usually written *homoiousians*, *homoousians*). To give solemn expression to their distinctive tenet the Eunomians changed the baptismal formula, 'I baptize thee in the name of the Father,' etc., to this: 'I baptize thee in the name of God, the Creator, into the death of Christ.' Consult Newman, J. H., 'Arians of the Fourth Century' (London 1886).

**EUNOMIUS**, Arian bishop: b. Dacora, Cappadocia; d. there about 395. In the controversy which gave rise to Arianism, Eunomius was an ardent disciple of Arius. So extreme were his views that he and his followers were looked upon as members of a party within the Arian ranks and were called Eunomians (q.v.). He was made bishop of Cyzicus in 360, but was deposed the following year as a result of his extreme views. He lived the life of an exile after this, but finally returned to his birthplace. He wrote a number of works, three of which are still in existence: 'Apologeticus,' 'Defence of the Defence' and 'Confession of Faith.' The first of these is in 'Patres Græci' (J. P. Migne, ed., Vol. XXX, Paris 1857-66) and has been translated into English by Whiston, W., 'The Apologetic of Eunomius' (in 'Primitive Christianity Revived,' Vol. I, London 1711). The fragments of the second have been collected by Rettberg, C. H. G., 'Marcelliana' (pp. 124-147, Göttingen 1794). Consult Klose, 'Geschichte und Lehre des Eunomius' (Kiel 1833).

**EUNUCH**, ū'nūk, a castrated male, generally used to take charge of the harem. Eunuchism is of prehistoric origin and prevailed among all Eastern nations and peoples and amongst those of the West which had been subject to Eastern influences. History refutes the general idea that eunuchs are deficient in courage and intelligence. In Persia, India, China, and during the later days of the Roman Empire, they frequently occupied, with great success, important military and civil positions. In modern times eunuchism is practiced extensively only in Moslem countries and even there it is gradually losing ground. Of secondary importance has been its practice for religious

reasons, an exaggerated development of asceticism. In the Christian Church it was, perhaps, most prevalent in the 3d century, though never officially countenanced.

**EUNUCHUS**, ū-nūk'ūs, a comedy of Terence and one of the best of his works, written in 161 B.C. Modern imitators are Sedley in 'Bellamira,' and La Fontaine in 'L'Eunuque.'

**EUOMPHALUS**, a fossil gastropod, having a spiral shell and found in Silurian and Triassic rocks, but most numerous in the Carboniferous Age.

**EUORNITHES**, ū-ōr'nī-thēz, a grand division of birds, which, according to some authors, includes all living birds except the ostriches and their allies and the penguins; and according to others includes all birds, modern and extinct, except Archæopteryx. In this sense it is equivalent to the preferable term *Neornithes* (q.v.).

**EUPALINUS OF MEGARA**, Greek architect, who constructed the great aqueduct for Polycrates on the island of Samos. Consult Smith, 'Dictionary of Greek and Roman Antiquities,' sub verbo, "Emissarium" (3d ed., London 1890).

**EUPATARIA**, or **EUPATORIA**, Russia, seaport, in the government of Taurida, on the Black Sea, 38 miles northwest of Simferopol. Having long been possessed by the Tartars of the Crimea (who gave it the name of Kosloff or Kesloff), it is more Asiatic than European in its aspect. The salt lake of Sakè is a bathing resort. Formerly in possession of the Turks it was annexed by Russia in 1783. It was here that the allied forces landed at the commencement of the Crimean War (14-18 Sept. 1854). It was unsuccessfully attacked by the Russians 17 Feb. 1855. Pop. 30,432.

**EUPATORIUM**, a genus of composite plants including many (about 600) species, especially characteristic of America, where several are well known. Among the most prominent are boneset or thoroughwort (*E. perfoliatum*), a native of low grounds, distinguished by the fact that its opposite leaves are joined around the stem; and the Joe-Pye-weed, or gravel-root (*E. purpureum*), whose purplish rosy flowers become conspicuous in late summer in wet meadows, borne on stems often 12 feet high. The hemp-agrimony is a well-known British medicinal herb. The flower-heads in this genus are in corymbs, all the florets tubular. Several of these plants have enjoyed from time immemorial a reputation in folk-medicine as remedies for the breaking up of fevers. Popular tradition has it that eupatorium is good for broken bones, the common name boneset preserving this notion. It has no such action. By reason of a certain amount of volatile and fixed oil which eupatorium contains it makes a fair diaphoretic mixture, and in the form of "boneset tea" it is of service in causing profuse sweating. This may be of service in the treatment of congestions in different parts of the body. See DIAPHORETICS.

**EUPATRIDES** (Gr. *εὐπατρίδαι*, *eupatridai*, well-born), the aristocracy, or land-owning class of ancient Athens, distinguished from the *geomiroi*, or peasants, and the *demiourgoi*, or artisans.

**EUPEN**, oī'pēn (Fr. *Néoux*), Germany, town in Rhenish Prussia, on the Wenzel, near the frontiers of Holland, 10 miles south-southwest of Aix-la-Chapelle. Its manufactures are numerous and varied. Eupen owes its manufacturing prosperity to the French refugees, who settled here while the town formed part of the duchy of Limburg, under Austrian rule. After the Peace of Lunéville, when this duchy was ceded to France, Eupen belonged to the department of Ourthe until the Peace of Paris in 1814, when this town, with other portions of Limburg, was ceded to Prussia. Pop. 14,000.

**EUPHEMISM**, a figure of speech by which one avoids the use of words directly expressing anything improper, disagreeable or painful by the employment of phrases that suggest in a more delicate manner or under a more cheerful aspect the idea to be conveyed. Thus the Greeks, in speaking of the Erinyes or Furies, came to call them the Eumenides, or well-disposed, gracious goddesses, and sometimes *semai theai*, "the august goddesses." Nearly all languages have some euphemism for death, or to express the fact that one has died, as when we speak of the "departed." In the Bible we have the phrases "he was gathered to his fathers," "he has fallen asleep," etc.; the Romans, with the same intention, said "he has lived" (*vixit*); the Germans say "he is ascended" (*er ist hinaufgegangen*), or "he has been made immortal" (*er ist verewigt worden*). On the same principle the Irish speak of the fairies as the "good people."

**EUPHORBIACEÆ**, ū-fōr-bi-ā'sē-ē (the Spurge family), a family of plants, consisting of more than 4,000 species of herbs, shrubs and trees arranged in about 220 genera, some of which are well known for their ornamental and economic uses. They are, with few exceptions, natives of warm climates, especially of tropical America, and nearly every species has an acrid juice, usually poisonous, but sometimes made bland when heated. Among the members of the family are many species of commercial importance. Thus the juice of some species and the roots of others are used in medicine, for in plants of this kind are found croton oil, castor oil, etc. A few of the Euphorbiaceæ yield fragrant balsamic products; a few, although their juice is poisonous, yield a wholesome starch in considerable abundance (see MANIOC); a few are cultivated and used as pot-herbs, particularly species of *Plukenetia* in the East Indies; a few yield wholesome and agreeable sub-acid fruits, as *Cicca disticha* and *C. racemosa* in the East Indies; the seeds of some are edible, as those of the candle-nut (q.v.), etc.; the oil of the seeds is also in some cases used for food, like other bland oils, but more frequently for burning, as castor oil, candle-nut oil, the oil of *Aleurites cordata* in Japan and Mauritius, and the solid oil of *Sapium sebiferum*, which is used in China for making candles, and in medicinal preparations as a substitute for lard. From *Hevea* is derived the highest grade of rubber produced in South America. Others yield dye-stuffs. The timber of some of the Euphorbiaceæ is valuable—for example, African teak. Of the numerous genera, many are represented in the American flora, the most important being *Croton Ricinus* (castor-oil plants), and *Euphorbia* or spurge proper. This genus numbers about

700 species, most abundant in the warm parts of the north temperate zone, more than 125 of them being found in America. They are all known as "spurge," and some are poisonous. Some one species is found in almost every part of America, those not native having escaped from cultivation. Some of the species are imposing ornamental plants and are much used in landscape gardening and in greenhouses, usually for their curious forms of growth, rather than for their beauty.

Plants of this family, although of widely differing forms of growth and foliage, are characterized by unisexual, monœcious or diœcious flowers, often brilliantly colored and often inconspicuous, in the latter case sometimes subtended by brilliantly colored bracts; the usually three-lobed fruits split elastically when ripe and throw the seeds to greater or less distances.

**EUPHORBIVM.** See GUMS.

**EUPHORBIVS,** in Greek mythology, one of the bravest of the Trojan heroes, the son of Panthous. He was slain by Menelaus in the Trojan War.

**EUPHORIVN,** Greek grammarian and poet: b. Chalcis, Eubœa, 276; d. about 200 B.C. He was educated at Athens and in 220 was appointed librarian to Antiochus the Great. He maintained secret amours with Nicia, wife of Alexander of Eubœa, reference to which frequently appears in the 'Greek Anthology.' He produced several works on history and grammar in prose, and in verse several elegies, epics and epigrams. Fragments of his works appear in Koch, 'Fragmenta Comicorum Græcorum' (Leipzig 1880), and Meinke, 'De Euphorionis Chalcidensis Vita et Scriptis' (Berlin 1823). Consult Christ-Schmid, 'Geschichte der griechischen Litteratur' (Munich 1911) and *Berliner Klassikertexte* (Vol. I, 1907).

**EUPHRANOR,** Greek sculptor and painter of the 4th century B.C. He lived at Corinth. His most famous statues were an Apollo, a Paris, a Leto, with Apollo and Artemis in her arms. His most celebrated painting was that representing 12 gods in the Stoa Basileios, at Athens. Consult Gardner, E. A., 'A Handbook of Greek Sculpture' (London 1911).

**EUPHRASIA,** a genus of plants of the figwort family (*Scrophulariaceæ*). It comprises about 110 species, natives of temperate and cold regions of both hemispheres, several of them occurring in North America. They are annual or perennial low-branched herbs, with small, blue, yellow or white flowers, generally known by the name eyebright. The principal American species are *E. arctica*, glandular eyebright and *E. americana*, hairy eyebright, the most widely distributed. The common English eyebright, *E. officinalis*, is not known in America. This is a very pretty little plant, the flowers white streaked with purple, and a yellow spot on the lip. It grows so abundantly in some places, as to give the ground an appearance of being covered with snow, during the time of its flowering, from May to September. The whole plant is slightly aromatic. It has been used with success in catarrhal inflammations of the eye, in cough, hoarseness, earache or headache which follow after catarrhs.

**EUPHRATES,** ū-frā'téz, a celebrated river in Asiatic Turkey, having its sources in central Armenia, at no great distance from the shores of the Euxine, and its mouth in the Persian Gulf; length, including windings, 1,716 miles. It is formed by the junction of two large streams, called the Kara-Su and the Mourad-Chai. These two head streams unite near Kaban Maden, about lat. 38° 58' N.; long. 38° 30' E.; from which point the river holds in the main a southeasterly course, until it falls into the Persian Gulf. At Korna, about 100 miles from its mouth, it is joined by the Tigris, and the united streams take the name of the Shatt-el-Arab. In point of current the Euphrates is for the most part a sluggish stream, except in the height of the flooded season. The Shatt-el-Arab has a depth of from three to five fathoms and presents banks covered with villages and cultivation. The most important town on the Shatt-el-Arab is Bassora or Basra. The melting of the snow in the mountains along the upper part of the river's course causes the Euphrates to rise. This takes place about the beginning of March and it increases gradually up to the end of May. The river continues high for 30 or 40 days; but afterward there is a daily decrease. From the middle of September to the middle of October the river is at the lowest. The Euphrates is navigable for a long distance from the sea, but there are numerous rapids. Steamers navigate the Shatt-el-Arab. Between the Euphrates and the Tigris lies the celebrated region Mesopotamia.

**EUPHROSIVNE,** ū-frôs'î-né (Lat., from Gr. *Εὐφροσύνη* the personification of joy, from *εὐφρων*, *euphron*, joyous), in Greek mythology, one of the three Graces (q.v.).

**EUPHTHALMINE,** ūf'thāl'mîn, an artificial alkaloid the hydrochlorate of which is used in solution in place of atropine and homatropine to dilate the pupil of the eye for examination with the ophthalmoscope. The great advantage it possesses is that the effect passes off within five hours and there is no danger of causing glaucoma, whereas atropine causes dilation for from 24 to 40 hours and homatropine for several days.

**EUPHIVS (ū'fū-ēz), OR THE ANATOMY OF WIT,** and **EUPHIVS AND HIS ENGLAND,** a book and its sequel, by John Lyly, published respectively in 1578 and 1580, when the author was a young courtier. They constitute the first and second part of a work which can only loosely be called fiction in the modern sense. Perhaps the word "romance" best expresses its nature. For 50 years the work was fashionable in the polite circles of England; and the word "euphuism" survives in the language to designate the stilted, far-fetched, ornate style of writing introduced and made popular by Lyly. Although Lyly's style had in it too much of the affected to give it long life, he undoubtedly did something toward making the 16th century speech refined, musical and choice. It is this rather than any attraction of story that makes the 'Euphuës' interesting to the modern student of literature. See EUPHIVSM.

**EUPHIVSM,** ū-fū'izm, an affected style of speech which distinguishes the conversation and

writings of many of the wits of the court of Queen Elizabeth. The name and the style were derived from 'Euphues, or the Anatomy of Wit' (1579), and the 'Euphues and His England' (about 1581), of John Lyly. It is probable that Lyly got his idea of these books from Ascham who, in his 'Schoolmaster,' published a short time before, had said that Euphues is "he that is apt by goodness of wit, and applicable by readiness of will to learning having all other qualities of the mind and parts of the body that must another day serve learning." At any rate Lyly adopted the word "Euphues" as the title of his hero, whom he developed in the sense in which Ascham used the Greek word "a man well endowed by nature." Lyly deliberately, in his writing, appealed to the audience of ladies throughout Britain for whom it was made light, pleasant and couched in high sounding English, which his followers soon styled "the new English." For over half a century 'Euphues' remained one of the most popular of books and its author was held to be one of the immortals. Among his most noted ardent admirers was Queen Elizabeth herself. These books which became the model of the wits and the gallants of the time, and an acquaintance with which was regarded as a test of courtly breeding, were characterized by smoothness and verbal elegance, but chiefly by fantastic similes and illustrations. Sir Walter Scott draws the portrait of a euphuist in the character of Sir Piercie Shafton, in 'The Monastery.' Consult Arber, 'Euphues' (1869), a complete edition; Bond, 'Complete Works of Lyly' (1902); Laudmann, 'Der Euphuismus' (1881). See EUPHUES.

**EUPHYLLOPODA.** See BRANCHIOPODA.

**EUPION**, ū'pī-ōn, or **EUPIONE**, Reichenbach's name for a fragrant colorless liquid produced in the destructive distillation of various animal and vegetable substances. It is highly volatile and inflammable; it is insoluble in water, but mixes with oils, and acts as a solvent for fats and resins. It is not readily acted on by ordinary chemical reagents.

**EUPOLEMUS**, Jewish historian, who lived in the 1st or 2d century B.C. He wrote a work with the title, 'Concerning the Kings of Judæa,' fragments of which have come to us through Clement Alexandrinus and Eusebius, Eupolemus claimed that Moses was the inventor of the alphabet and that from him it passed to the Phœnicians and Greeks. For the fragments consult Kuhlmeijer, 'Eupolemi Fragmenta' (Berlin 1840) and Müller, 'Fragmenta Historicorum Græcorum' (Vol. III, Leipzig 1849). Consult Schürer, 'Geschichte des jüdischen Volkes' (4th ed., Leipzig 1909) and Willrich, 'Juden und Griechen' (Göttingen 1905).

**EUPOLIS**, Greek poet: b. about 446; d. 411 B.C. In 429 appeared his first play, written when he was about 17. Suidas relates that he wrote altogether 17 pieces and was awarded 10 prizes. Early in his literary career he was on intimate terms with Aristophanes, with whom he collaborated. Later they became enemies and Eupolis was accused of plagiarism. Fragments of his works are found in Meineke, 'Fragmenta Comicorum Græcorum' (Vols. I and II, Berlin 1839-57) and Koch, 'Fragmenta Comicorum Atticorum' (Leipzig 1880). Con-

sult Christ-Schmid, 'Geschichte der griechischen Litteratur' (6th ed., Munich 1911).

**EURAQUILO**, ū-räk'wī-lō, the name given by the sailors to the east-northeast wind which wrecked the ship on which Saint Paul was traveling to Rome (Acts xxvii, 13, 14). The Authorized Version adopted the incorrect Euroclydon from a faulty manuscript, probably.

**EURASIANS.** See ANGLO-INDIANS.

**EURE**, ěr, France, a department in the northwest forming part of Normandy; area, 2,331 square miles. The chief river which flows through it is the Seine, of which the Eure and the Rille are the most important tributaries. Wheat is the principal crop, and the mining and manufacturing industries are extensive. Capital, Evreux. Pop. 323,651.

**EURE**, a river of France, which has given its name to two departments— that of the Eure, and that of the Eure-et-Loir. The river rises in the department of the Orne, and flows into the Seine, near Pont-de-l'Arche, after a course of 124 miles, being navigable for about half the distance.

**EURE-ET-LOIR**, ěr-ā-lwār, France, a department in the northwest, forming part of the old provinces of Orléannais and Normandy; area, 2,293 square miles. The department is essentially agricultural, and has few manufactures. The capital is Chartres. Pop. 272,255.

**EUREKA**, ū-rĕ'ka, a Greek word meaning "I have found it"; used as an expression of triumph at a discovery. See ARCHIMEDES.

**EUREKA**, Cal., city, county-seat of Humboldt County, on Humboldt Bay, the Eel River and the Northwestern Pacific Railroad, 225 miles northwest of San Francisco. It has a fine harbor, which has been improved by the United States government on the jetty plan. The city is situated in the famous redwood region, and has large lumber interests. Sequoia Park, a tract of 40 acres of redwood forest, is near the city. The noteworthy features are the Carnegie library, Federal building, county jail, hospital, city hall and courthouse. An extensive trade is carried on in redwood lumber, shingles, butter, fish, apples and wool, the exports in 1912 amounting to \$10,960,000. There are shingle mills, tobacco factories, bottling works, sash and door factories, marble and granite works, a tannery, iron foundry, woolen mill, etc. The United States census of manufactures for 1914 showed within the city limits 57 industrial establishments employing 928 persons; 799 being wage earners receiving annually a total of \$605,000 in wages. The capital invested aggregated \$2,976,000, and the year's output was valued at \$2,480,000; of this, \$1,263,000 was the value added by manufacture. The government, under a charter of 1895, is vested in a mayor, elected biennially, and a municipal council. First settled in 1850, Eureka became the county seat and was incorporated in 1856. The city has gas and electric lights, high schools, daily and weekly newspapers, and five banks. Pop. 13,768.

**EUREKA**, Ill., city and county-seat of Woodford County, on the Atchison, Topeka and Santa Fe and the Toledo, Peoria and Western railroads, 20 miles east of Peoria. Eureka College, under the auspices of the



Christian Church, was established in 1855. The city is a trade centre for the surrounding agricultural community. Eureka was incorporated as a town in 1856. The waterworks are owned by the municipality. Pop. 1,525.

**EUREKA**, Kan., city, county-seat of Greenwood County, on Fall River, and on the Atchison, Topeka and Santa Fe and the Missouri Pacific railroads, about 58 miles northeast of Wichita. It is the seat of the Southern Kansas Academy, under the auspices of the Congregational Church. There is a Carnegie library. The city is a trade centre for the surrounding rich agricultural region. Eureka has adopted the commission form of government and owns its waterworks. Pop. 2,333.

**EUREKA**, Nev., town, county-seat of Eureka County, on the Southern Pacific Railroad. It was once a productive mining camp, producing great quantities of lead, gold and silver; and many other valuable minerals. The town has numerous and important smelting and refining works. Because of severe fires, destroying a large portion of the place, the population decreased from 5,000 in 1880 to 661 in 1910.

**EUREKA**, Utah, city of Juab County, 90 miles southwest of Salt Lake City, on the San Pedro, Los Angeles and Salt Lake, and the Rio Grande Western railroads. It has copper smelting works and quartz mills and a Carnegie library. Copper and silver are mined in the neighborhood. Pop. 3,416.

**EUREKA COLLEGE**, coeducational institution in Eureka, Ill.; founded in 1855 under the auspices of the Christian Church; reported at the close of 1915: Professors and instructors, 26; students 273; and volumes in the library, 12,000.

**EUREKA SPRINGS**, Ark., city and county-seat of Carroll County, on the Jefferson Highway and the Missouri and North Arkansas Railroad, 175 miles northwest of Little Rock. It is a noted health and pleasure resort to which 30,000 visitors come annually. The shipping of water from the springs is the principal industry. It has two banks with combined resources of \$550,000, taxable property valued at \$1,875,000, public and high schools and is the seat of the Crescent Cottage for Women. The chief public buildings are the city hall, United States post office and the county courthouse. It has also several large hotels catering to tourists. The receipts of the city amount to about \$18,000 annually. The commission form of government is in operation. Pop. 3,800.

**EURIC**, a king of the Visigoths (q.v.).

**EURINGER**, oi'ring-ër, Sebastian, German Semitic scholar: b. Augsburg, 1865. He was educated at Munich, Heidelberg, Freiburg, Strassburg, Tübingen and at the Ecole Biblique Pratique at Jerusalem. He entered the ministry in 1887 and preached for two years, after which he toured Egypt and Palestine. From 1894 to 1900 he held a pastorate near Augsburg and in the latter year was appointed professor in the Dillingen Lyceum. He has published 'Der Masorahstext des Kohelet' (1890); 'Die Auffassung des Hohenliedes bei den Abes-

sinieren' (1900); 'Die Chronologie der biblischen Urgeschichte' (1909); 'Die Kunstform der althebräischen Poesie' (1912); 'Ein unkanonischer Text in der armenischen Bibel' (1913).

**EURIPIDES**, son of Mnesarchus, a retail dealer of the Attic village, Phlya: b. 480 B.C. on the island of Salamis, and, according to tradition, on the day of the famous battle; d. 406. His mother's name was Clito, which indicates aristocratic lineage. Under the influence of his father Euripides first paid attention to athletics, then to painting, and finally to philosophy. He learned much from Protagoras, from Prodicus and from Anaxagoras, with whom he holds that nothing which exists perishes. The poet entered upon his real career at 25. His first success was limited, but he became more and more the favorite of the people. The popularity of his plays at the close of his life and throughout late antiquity was extraordinary. Later comedy was based on his methods. The Romans had a strong predilection for him. In modern times the admiration for Euripides was unbounded until Schlegel set up a standard against him. But Schlegel is unfair: a poet must be measured by his aims. Nevertheless, the poet's works failed at first to win the approval of the Athenians. He was unsuccessful until he was 38, and he won only five first prizes in his whole life. He was also personally unpopular, for he was essentially a pessimist. He felt that the evil in life was not counterpoised by good. He loved retirement and sequestration from open haunts and popularity; preferred the contemplative life of the student to the active life of the statesman. He even acquired the reputation of being a morose cynic, vicious in his private life despite his austere exterior. His gloomy visage, rendered doubly so by unhappy domestic relations, was not attractive to the Athenians, who detested an unsocial disposition. So he lived the life of a recluse, on his estate at Salamis, rapt in secret studies. His library was dukedom enough for him. Late in his life he repaired to the court of Archelaus, king of Macedonia. Here he died in 406. The Macedonians built him a magnificent tomb at Pella. The Athenians erected for him a cenotaph in Athens.

Euripides is the most rhetorical of the three tragic poets, because he is most affected by the spirit of the new school. He is the representative of the new Athens, of the new ideas which were crowding out the simpler beliefs of the Æschylean and Sophoclean school. Euripides is nearer ourselves. He marks the transition to the modern world. The antique standard cannot be applied to him. With Alfred de Musset he might have said: "je ne puis m' en fuir hors de l'humanité." His heart is full of compassion for the poor. None is too lowly for his Alcestis to address, as she bids farewell to the household. Euripides was the first dramatic poet to hold aloof from the world. But the motive was not pure indifference: he spoke to a larger audience. No tragedian treated a greater number of patriotic themes; but he had no affection for the demagogue. The pomp and glory of war had no fascination for him. The suffering of all humanity appeals to his generous heart. In

the cosmopolitanism of Socrates, traces of which we find in Euripides, he anticipates Goethe. A poetic associate of the sophists, he was naturally not orthodox. He did not actually deny the existence of the gods—that were dangerous in Athens and in the theatre impossible. Euripides simply puts the question to his audience and so troubles their souls. He shrinks from discussing no question of heaven or earth. Toward the close of his life he is supposed to have drawn nearer to the religion of his fathers, but the only monument of this change is that remarkable play, the 'Bacchæ.' No chronological development in his religious views can be shown. He was a skeptic and a seeker after truth, but not a creative philosopher. No other poet gives us a better conception of what the truth-seeking Athenian knew and read.

Much has been written about the poet's hatred of women. But we have only to read the 'Alcestis,' or 'Iphigenia,' to discover that he can portray the noblest types of womanhood. Euripides knew *le mal que peut faire une femme*, but no man understood better the capabilities of woman's nature. He is the first Greek after Homer that showed any approach to a just conception of what under normal circumstances woman may and should be to society. True, he assailed fiercely a certain type of woman, but this does not prove that the women of his time were especially depraved. Often the condemnation is due to the dramatic situation. He does satirize the women of his time for their gossiping disposition, for their cleverness and for their love of slander with a persistence that leaves no doubt as to his intentions; but, being a pessimist, his mind emphasized the bad rather than the good.

The plays of Euripides are not so subtle in structure as those of Sophocles. He cared more for striking situations than for articulated plots, more for thrilling scenes than for unity and symmetry of the whole. But he made a special study of the recognition as leading to the dénouement. Another innovation of Euripides was the introduction of the prologue. In the very beginning he gives the entire setting of the piece, relates all the circumstances. This mechanical opening has been criticized as flat and jejune. But he worked on a different plan from Sophocles. Like Lessing, he believed that the audience should know more than the characters themselves. He disdained to excite vulgar curiosity. So he conceived the prologue as an integral part of the play. Moreover, he leaves the most important part untold; the audience does not know at the outset how the poet proposes to treat the myth; hence the pleasure of surprise is not entirely lacking. The audience enjoys also the sudden revelations to the individual characters. Furthermore, the Greeks cared more for the quiet contemplation of situations than we do. Nevertheless, this practice of beginning the play with a prologue became a mannerism and was justly ridiculed by Aristophanes. Euripides' plays have also a mechanical ending—when the conflict seems insoluble, the *deus ex machina* interferes expressly to solve difficulties, to cut the cords atwain that seem too intrinsic to loose. This is not high antique art; but the flaw-hunters unduly emphasize

the defect. Many of the plays also break in two in the middle. This is, indeed, a fault. Nevertheless, the scenes are interesting, sometimes stirring. Often the thoughts expressed are not adapted to the speaker; and the choral odes frequently seem irrelevant. The poet's monodies constitute an undue proportion of the lyrical element.

We have 80 titles of plays, but very few fixed dates. There are 19 extant dramas—18 tragedies and one satyr drama ('Cyclops'). The 'Rhesus,' regularly printed in the editions of the Euripidean corpus, is certainly not by Euripides. The earliest extant play is the 'Alcestis' (438); the most famous is the 'Medea' (431); but probably the two greatest tragedies are the 'Hippolytus' (428) and the 'Bacchæ' (407). One of the most interesting is the 'Iphigenia in Tauris' (414) and the most charming the 'Ion' (about 416). The other plays with approximate dates are 'Iphigenia in Aulis' (407), 'Orestes' (408), 'Phœnissæ' (410), 'Helen' (412), 'Electra' (413), 'Troades' (415), 'Andromache' (417), 'Heracles' (418), 'Supplices' (420), 'Hecuba' (424), 'Heraclidæ' (430). See ALCESTIS; MEDEA.

JOSEPH E. HARRY,

Author of 'The Greek Tragic Poets.'

**EURIPUS**, ù-rî'pûs, in ancient geography, the strait between the island of Eubœa and the mainland, Bœotia in Greece. At Chalcis, the width at the narrowest part was 120 feet. The term Euripus is also sometimes applied to the southeast part of the Eubœan Channel.

**EUROCLYDON**, ù-rök'li-dön, a tempestuous wind that frequently blows in the Levant, and which was the occasion of the disastrous shipwreck of the vessel in which Saint Paul sailed, as narrated in Acts xxvii, 14-44. In the form in which the word is found in the revised version it must be taken as made up of the two Greek words, *euros*, the east or rather southeast wind, and *klydön*, a wave. But the word used for it in the Vulgate is *Euro-aquilo*, a Latin compound signifying a northeast wind; and some of the best MSS. have the reading *Eurakylön* instead of *Euroclydon*, which is accepted by some scholars as the preferable reading. Whatever may have been the true form of the word, it was applied to a northeast or north-northeast, and not an east or southeast wind, as the course taken by the vessel referred to indicates. Exactly such a wind is described by sailors of the present day as prevalent at certain seasons (especially in early spring) in the Mediterranean. The name by which the wind is now known is *Gregalia*.

**EUROPA**, ù-rö'pa, in Greek mythology, the daughter of Agenor or of Phœnix, king of the Phœnicians, and a sister of Cadmus. The fable relates that she was abducted by Jupiter, who assumed the form of a bull, and swam with his prize to the island of Crete. Here Europa bore to him Minos, Sarpedon and Rhadamanthlus. Zehus made her miraculous presents, Talos (a bronze man), a dog that always kept track of his prey and a spear that never missed its mark. By his order also she became the wife of Asterius, king of Crete. As Hellotia, Europa was worshipped in Crete in the capacity of the goddess of fertility. She









seems to have been originally a moon deity and a patroness of hunting.

**EUROPA, Rape of.** See TITIAN; VERONESE, PAUL.

**EUROPE**, the smallest of the great continents but the most important, distinguished above the others by the character of its population, the superior cultivation of the soil, and the flourishing condition of arts, sciences, industry and commerce.

**Topography.**—Europe forms a huge peninsula projecting from Asia, and is bounded on the north by the Arctic Ocean on the west by the Atlantic Ocean; on the south by the Mediterranean, the Black Sea and the Caucasus Range; on the east by the Caspian Sea, the Ural River and the Ural Mountains. The most northerly point on the mainland is Cape Nordkyn, in Lapland, in lat.  $71^{\circ} 6' N.$ ; the most southerly points are Punta da Tarifa, lat.  $36^{\circ} N.$ , and the Strait of Gibraltar, and Cape Matapan, lat.  $36^{\circ} 17'$ , which terminates Greece. The most westerly point is Cape Roca in Portugal, in long.  $9^{\circ} 28' W.$ , while Ekaterinburg is in long.  $60^{\circ} 36' E.$  From Cape Matapan to North Cape is a direct distance of 2,400 miles, from Cape Saint Vincent to Ekaterinburg, northeast by east, 3,400 miles; area of the continent, about 3,800,000 square miles. Great Britain and Ireland, Iceland, Nova Zembla, Corsica, Sardinia, Sicily, Malta, Crete, the Ionian and the Balearic Islands are the chief islands of Europe. The shores are very much indented, giving Europe an immense length of coast line (estimated at nearly 50,000 miles). The chief seas or arms of the sea are the White Sea on the north; the North Sea, or the German Ocean, on the west, from which branches off the great gulf or inland sea known as the Baltic; the English Channel, between England and France; the Mediterranean, communicating with the Atlantic by the Strait of Gibraltar (at one point only 19 miles wide); the Adriatic and the Ægean seas, branching off from the Mediterranean, and the Black Sea, connected with the Ægean Sea through the Hellespont, Sea of Marmora and Bosphorus.

The mountains form several distinct groups or systems of very different geological dates, the loftiest mountain masses being in the south central region. The Scandinavian mountains in the northwest, to which the great northern peninsula owes its form, extend above 900 miles from the Polar Sea to the southern point of Norway. The highest summits are about 8,000 feet. The Alps, the highest mountains in Europe (unless Mount Elbruz in the Caucasus is claimed as European), extend from the Mediterranean first in a northerly and then in an easterly direction, and attain their greatest elevation in Mont Blanc (15,781 feet), Monte Rosa and other summits. Branching off from the Alps, though not geologically connected with them, are the Apennines, which run southeast, through Italy, constituting the central ridge of the peninsula. The highest summit is Monte Corno (9,541 feet). Mount Vesuvius, the celebrated volcano in the south of the peninsula, is quite distinct from the Apennines. By southeastern extensions the Alps are connected with the Balkan and the Despot-Dagh of the southeastern peninsula of Europe. Among the moun-

tains of southwestern Europe are several massive chains, the loftiest summits being in the Pyrenees, and in the Sierra Nevada in the south of the Iberian Peninsula. The highest point in the former, La Maladetta or Mont Maudit, has an elevation of 11,165 feet; Mulahaven, in the latter, is 11,703 feet, and capped by perpetual snow. West and northwest of the Alps are the Cévennes, Jura and Vosges; north and northeast, the Harz, the Thüringerwald Mountains the Fichtelgebirge, the Erzgebirge and Böhmerwaldgebirge. Farther to the east the Carpathian chain encloses the great plain of Hungary, attaining an elevation of 8,000 or 8,500 feet. The Ural Mountains between Europe and Asia reach the height of 5,540 feet. Besides Vesuvius two other volcanoes are Etna in Sicily, and Hecla in Iceland. A great part of northern and eastern Europe is level. The "great plain" of North Europe occupies part of France, western and northern Belgium, Holland the northern provinces of Germany, and the greater part of Russia. A large portion of this plain, extending through Holland and North Germany, is a low sandy level not infrequently protected from inroads of the sea only by means of strong dykes. The other great plains of Europe are the plain of Lombardy (the most fertile district in Europe) and the plain of Hungary. Part of southern and southeastern Russia consists of steppes.

**Rivers and Lakes.**—The main European watershed runs in a winding direction from southwest to northeast, at its northeastern extremity being of very slight elevation. From the Alps descend some of the largest of the European rivers, the Rhine, the Rhône and the Po, while the Danube, a still greater stream, rises in the Black Forest north of the Alps. The Volga, which enters the Caspian Sea, an inland sheet without outlet, is the longest of European rivers, having a direct length of nearly 1,700 miles, including windings of 2,400 miles. Into the Mediterranean flow the Ebro, the Rhône and the Po; into the Black Sea, the Danube, Dnieper Dniester and Don (through the Sea of Azov); into the Atlantic, the Guadalquivir, the Guadiana, the Tagus and Loire; into the English Channel, the Seine; into the North Sea, the Rhine, Elbe; into the Baltic, the Oder, the Vistula and the Duna; into the Arctic Ocean, the Dwina. The lakes of Europe may be divided into two groups, the southern and the northern. The former run along both sides of the Alps, and among them, on the north side, are the lakes of Geneva, Neuchâtel, Thun, Lucerne, Zürich and Constance; on the south side, Lago Maggiore, and the lakes of Como, Lugano, Iseo and Garda. The northern lakes extend across Sweden from west to east, and on the east side of the Baltic a number of lakes, stretching in the same direction across Finland on the borders of Russia, mark the continuation of the line of depression. It is in Russia that the largest European lakes are found—Lakes Ladoga and Onega.

**Geology.**—The geological features of Europe are exceedingly varied. The older formations prevail in the northern part as compared with the southern half and the middle region. North of the latitude of Edinburgh and Moscow there is very little of the surface of more recent origin than the strata

of the upper Jura belonging to the Mesozoic Period, and there are vast tracts occupied either by eruptive rocks or one or other of the older sedimentary formations. Denmark and the portions of Germany adjoining belong to the Cretaceous Period, as does also a large part of Russia between the Volga and the basin of the Dnieper. Middle and eastern Germany with Poland and the valley of the Dnieper present on the surface Eocene formations of the Tertiary Period. The remainder of Europe is remarkable for the great diversity of its superficial structure, rocks and deposits belonging to all periods being found within it, and having for the most part no great superficial extent. Europe possesses abundant stores of those minerals which are of most importance to man, such as coal and iron, Great Britain being particularly favored in this respect. Coal and iron are also obtained in France, Belgium and Germany. Gold is found to an unimportant extent, and silver is widely spread in small quantities. The richest silver ores are in Norway, Spain, the Erzgebirge and the Harz Mountains. Spain is also rich in quicksilver. Copper ores are abundant in the Ural Mountains, Thuringia, Cornwall and Spain. Tin ores are found in Cornwall, the Erzgebirge and Brittany.

**Climate.**—Several circumstances concur to give Europe a climate peculiarly genial, such as its position almost wholly within the temperate zone, and the great extent of its maritime boundaries. Much benefit is also derived from the fact that its shores are exposed to the warm marine currents and warm winds from the southwest, which prevent the formation of ice on most of its northern shores. The eastern portion has a less favorable climate than the western. The extremes of temperature are greater, the summer being hotter and the winter colder, while the lines of equal mean temperature decline south as we go east. The same advantages of mild and genial temperature which western has over eastern Europe, the continent collectively has over the rest of the Old World. The diminution of mean temperature, as well as the intensity of the opposite seasons, increases as we go east. Peking, in lat. 40° N., has as severe a winter as Petrograd in lat. 60°.

**Botany.**—With respect to the vegetable kingdom Europe may be divided into four zones. The first, or most northern, is that of fir and birch. The birch reaches almost to North Cape; the fir ceases a degree farther south. The cultivation of grain extends farther north than might be supposed. Barley ripens even under the 70th parallel of north latitude; wheat ceases at 64° in Norway to lat. 62° in Sweden. Within this zone the southern limit of which extends from lat. 64° in Norway to lat. 62° Russia, agriculture has little importance, its inhabitants being chiefly occupied with the care of reindeer or cattle, and in fishing. The next zone, which may be called that of the oak and beech, and cereal produce, extends from the limit above mentioned to the 48th parallel. The Alps, though beyond the limit, by reason of their elevation belong to this zone, in the moister parts of which cattle husbandry has been brought to perfection. Next we find the zone of the chestnut and vine, occupying the space between the 48th parallel and the mountain chains of south-

ern Europe. Here the oak still flourishes, but the pine species become rarer. Rye, which characterizes the preceding zone on the continent, gives way to wheat, and in the southern portion of it to maize also. The fourth zone, comprehending the southern peninsula, is that of the olive and evergreen woods. The orange, lemon and olive flourish in the southern portion of it, and rice is cultivated in a few spots in Italy and Spain.

**Zoology.**—As regards animals the reindeer and polar bears are peculiar to the north. In the forests of Poland and Lithuania the urus, a species of wild ox, is still occasionally met with. Bears and wolves still inhabit the forests and mountains; but, in general, cultivation and population have expelled wild animals. The domesticated animals are nearly the same throughout. The ass and mule lose their size and beauty north of the Pyrenees and Alps. The Mediterranean Sea has many species of fish, but no great fishery; the northern seas, on the other hand, are annually filled with countless shoals of a few species, chiefly the herring, mackerel, cod and salmon.

**Inhabitants.**—Europe is occupied by several different peoples or races, in many parts now greatly intermingled. The Celts once possessed the west of Europe from the Alps to the British Islands. But the Celtic nationalities were broken by the wave of Roman conquest, and the succeeding invasions of the Germanic tribes completed their political ruin. At the present day the Celtic language is spoken only in the Scotch highlands (Gaelic), in some parts of Ireland (Irish), in Wales (Cymric) and in Brittany (Armorican). Next to the Celtic comes the Teutonic race, comprehending the Germanic and Scandinavian branches. The former includes the Germans, the Dutch and the English. The Scandinavians are divided into Danes, Swedes and Norwegians. To the east, in general, of the Teutonic race, though sometimes mixed with it, come the Slavonians, that is, the Russians, the Poles, the Czechs or Bohemians, the Serbians, Croatsians, etc. In the south and southeast of Europe are the Greek and Latin peoples, the latter comprising the Italians, French, Spanish and Portuguese. All these peoples are regarded as belonging to the Indo-European or Aryan stock. To the Mongolian stock belong the Turks, Finns, Lapps and Magyars or Hungarians, all immigrants into Europe in comparatively recent times. The Basques at the western extremity of the Pyrenees are a people whose affinities have not yet been determined. The total population of Europe is about 425,000,000; nine-tenths speak the languages of the Indo-European family, the Teutonic group numbering about 108,000,000, the Slavonic and Latin over 95,000,000 each. The prevailing religion is the Christian, embracing the Roman Catholic Church, the various Protestant bodies and the Greek Church. A part of the inhabitants profess the Jewish, a part the Mohammedan religion.

**Political Divisions.**—The states of Europe, with their respective areas and populations, are as shown below.

**Area and Population.**—The following table shows the countries with their government, area and population according to 'The Statesman's Year Book' (1916).







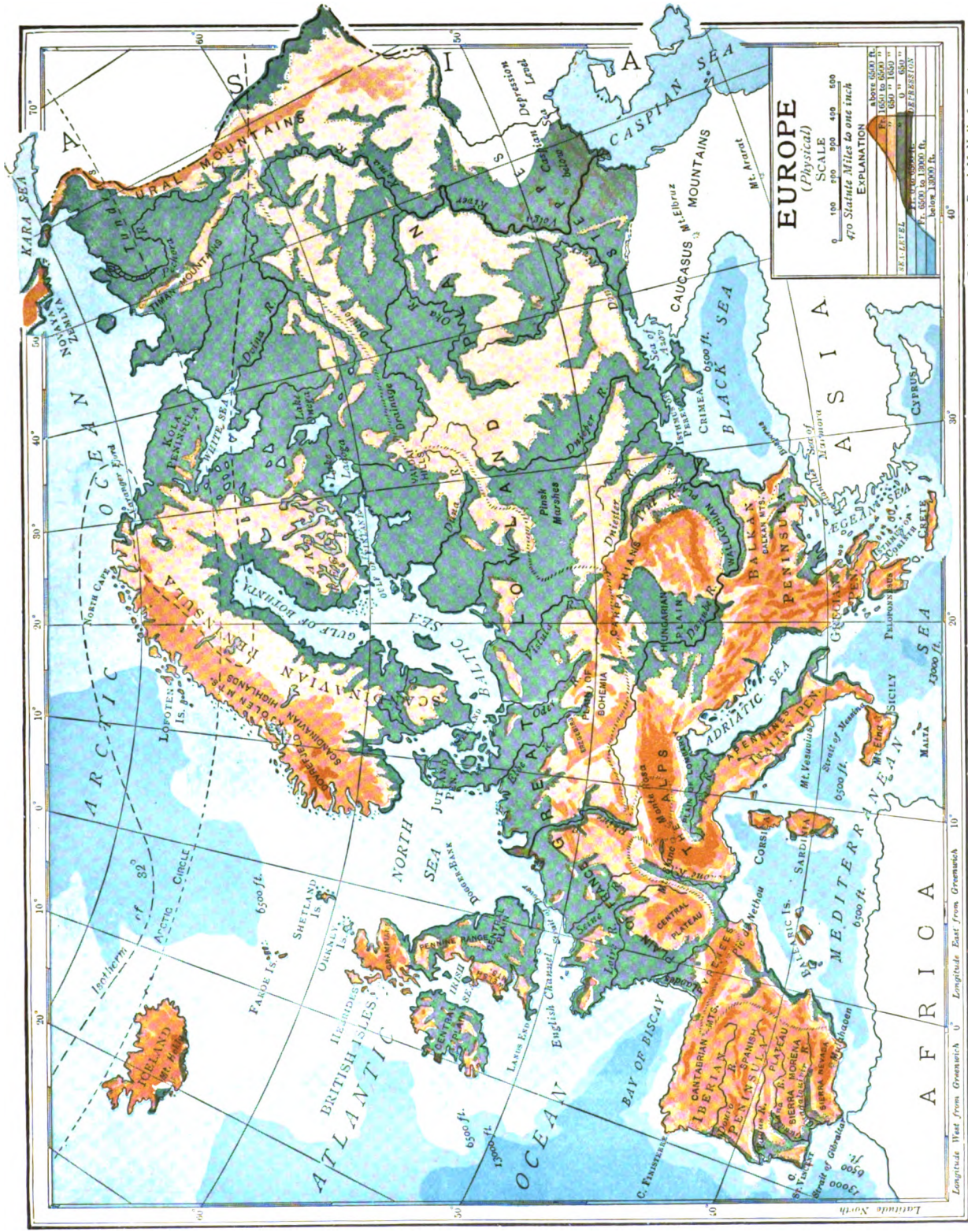



COUNTRIES	Government 1917	Area in Eng. Sq. M.	Population
Andorra	Republic	175	5,231
Austria-Hungary	Empire	241,333	(1910) 49,211,427
Belgium	Kingdom	11,373	(1910) 7,423,784
Bulgaria	Principality	43,305	(1914) 4,752,997
Denmark	Kingdom	15,592	(1911) 2,775,076
France	Republic	207,054	(1911) 39,601,509
Germany	Empire	208,780	(1910) 64,925,993
Great Britain and Ireland	Kingdom	121,391	(1911) 45,370,530
Greece	Kingdom	41,933	(1914) 4,821,300
Italy	Kingdom	110,659	(1915) 36,120,118
Lechtenstein	Principality	65	(1912) 10,716
Luxemburg	Grand Duchy	998	(1910) 259,891
Monaco	Principality	8	(1913) 22,956
Montenegro	Kingdom	5,603	516,000
Netherlands	Kingdom	12,648	(1914) 6,339,705
Norway	Kingdom	124,130	(1910) 2,391,782
Portugal	Republic	35,490	(1911) 5,975,985
Rumania	Kingdom	53,489	(1912) 7,508,009
Russia (European)	Empire	1,867,524	(1914) 128,864,300
San Marino	Republic	38	11,513
Serbia	Kingdom	18,650	(1910) 2,911,701
Spain	Kingdom	194,783	(1910) 19,995,446
Sweden	Kingdom	172,963	(1914) 5,679,607
Switzerland	Republic	15,976	(1913) 3,877,210
Turkey (European)	Empire	10,882	1,891,000
Bosnia, Herzegovina and Novi Bazar, occupied by Austria-Hungary	Empire	19,768	(1912) 1,962,411

**Bibliography.**—Adams, 'European History' (1899); Allison, 'History of Europe' (1853); Bryce, 'The Holy Roman Empire' (1877); Duruy 'General History' (1898); Dyer, 'History of Modern Europe' (1901); Fyffe, 'History of Modern Europe' (1890); Freeman, 'Historical Geography of Europe' (1881); Gibbon, 'Decline and Fall of the Roman Empire' (ed. 1902); Hassell, 'Handbook of European History' (1897); Lodge, 'History of Modern Europe' (1885); May, 'Democracy in Europe' (1877); McCarthy, 'History of Our Own Times' (1888); Munroe, 'History of the Middle Ages' (1902); Rose, 'A Century of Continental History' (1880); Robinson, 'History of Western Europe' (1902); Schnill, 'History of Modern Europe' (1902); 'Cambridge Modern History' (14 vols., New York 1902-12); Herre, 'Quellenkunde zur Weltgeschichte' (Leipzig 1910); Stanford, 'Compendium of Geography and Travel' (13 vols., London 1907).

**EUROPEAN CITIES, Government of.** See CITIES, EUROPEAN, GOVERNMENT OF.

**EUROPEAN FURNITURE.** See FURNITURE, MÆDIEVAL.

**EUROPEAN HISTORY.** For outline of European history from the earliest period to the present time see HISTORY, ANCIENT; HISTORY, MÆDIEVAL; HISTORY, MODERN. See also the articles on the Centuries—FIRST CENTURY; SECOND CENTURY, etc., and the history of the various nations under their own titles.

**EUROPHEN,** a yellow powder containing 27.6 per cent of iodine. Heat and moisture applied set the iodine free. Europhen is easily soluble in alcohol, ether or chloroform, but is insoluble in water. In action it is similar to iodoform, to which it is often preferred because of its pleasant odor.

**EUROPIUM,** a chemical element found in small quantities in monazite sand. Its symbol is Eu; atomic weight, 152; it is known in the metallic state.

**EUROTAS,** ū-rō'tas, or IRI, a river of southern Greece (Peloponnesus), at one time

called the Iris and Niris in the upper and the Basilipotamo (King's River) in the lower part of its course. It flows in a southerly direction through the valley between the ranges of Taygetus and Parion, and enters the Gulf of Kolokytha. Amyclæ and Sparta were on the Eurotas.

**EUROTIA,** a genus of the goosefoot family (*Chenopodiaceæ*), which comprises two or three species, one of which, *E. lanata*, is found in western North America, and is generally known as white sage. It is a many-branched shrub, from one to three feet high, the flowers densely covered with long silky hairs. It is also called winter fat, being used by cattle as a winter forage.

**EUROTIIUM,** ū-rō'shī-ūm, the common mold which appears on bread, preserves, etc., and often called herbarium mold. *Aspergillus* is the generic name now in most general use.

**EURUS,** the southeast wind, also in Greek mythology, the son of Astræus and Eos. See GREEK MYTHOLOGY.

**EURYALE,** ū-rī'a-lē, a genus of the water lily family (*Nymphæaceæ*). It has but one species, *Euryale ferox*, a native of China and southeastern Asia. The plant is covered with spines; the flowers are small, red or purplish, and the leaves very large, sometimes four feet in diameter. The seeds are rich in starch, and in the native countries of the plant are an article of commerce, being roasted and eaten or used in soups. The root is also eaten. The plant is hardy and will grow out of doors in America and reproduce itself as far north as Baltimore.

**EURYBIADES,** ū-rī-bī'a-dēs, admiral of the Spartan fleet and commander of the united Greek fleets against the Persians in 480 B.C. With Themistocles he shares the glory of the battle of Salamis.

**EURYCLEA,** the nurse of Odysseus, who recognized the latter on his return by a scar disclosed while washing his feet and reported the matter to Penelope.

**EURYDICE**, ū-rid'i-sē, in Greek mythology, the wife of Orpheus, who died by the bite of a serpent. Her husband, inconsolable for her loss, descended to the lower world, and, by the charms of his lyre, moved the infernal deities to grant him permission to bring her back. This they granted, on condition that he would not look back upon her till he had reached the upper world. Forgetting his promise, he looked and lost her forever. This story has often formed a subject for poets—as for Virgil in the *Georgics* (book iv), and for Pope in his 'Ode on St. Cecilia's Day.' One of the first modern operas was the 'Eurydice' (Euridice) of Coccini and Peri. It was first produced at Florence in 1600. The name Eurydice was borne by certain Macedonian princesses.

**EURYLOCHUS**. See **CIRCE**.

**EURYMACHUS**, the son of Polybus and a suitor of Penelope. With the other suitors he was killed by Odysseus.

**EURYMEDON**, Athenian general. He was commander of a fleet at Corcyra in 428 B.C., and three years later, with Sophocles, son of Sostratides, led an expedition against Sicily. On arrival there they made peace with Hermocrates, which the Athenians suspected to have been brought about by bribery. Eurymedon was heavily fined, but in 414 was sent to reinforce the Athenians at Syracuse and lost his life before reaching Sicily.

**EURYMONE**, ū-rim'ō-nē, an infernal deity, who gnawed the dead to the bones and was always grinding her teeth. Also a daughter of Apollo.

**EURYNOME**, ū-rin'ō-mē, in Greek mythology, the daughter of Oceanus and mother of the Graces and of Zeus, and the wife of the Titan Ophion, the ruler of Olympus. In her temple at Phigolia she was represented as half woman and half fish.

**EURYPTERUS**, ū-rīp'tē-rūs, a remarkable fossil arthropod related to the horseshoe crab (*Limulus*), many genera and species of which occur in Palaeozoic rocks of western Europe and eastern North America. They include the largest arthropods known, and form the family *Eurypterida* and order *Eurypterida* of the subclass *Merostomata* (q.v.). They resembled the modern horseshoe crabs in structure, but had elongated, often scorpion-like bodies, terminating in a hinged, spike-like or flattened tail or telson. The most remarkable feature, however, is the great size they attained, some exceeding six feet long, so that they were well named by Haeckel *Gigantostroaca*. The surface was formed by a thin chitinous epidermal skeleton, ornamented by fine scale-like markings, and bearing upon the head-shield two large lateral faceted eyes and a pair of median ocelli. Beneath the cephalo-thorax are six pairs of legs, the foremost preoral, the basal joints of which serve as jaws. The last pair is greatly enlarged, somewhat flattened and terminated by an oval plate, which suggests that these limbs served as paddles in swimming, but they may have been otherwise useful. In *Pterygotus* and some allied genera the preoral limbs are modified into more or less antennæ-like organs terminating in toothed pincers (chelæ), no doubt for seizing prey, etc. The ventral segments are 13, of which the first two bear the genital organs, and

the remainder leaf-like structures regarded as respiratory and equivalent to the "bookgills" of *Limulus*. These extraordinary crustaceans are found associated with graptolites, cephalopods and trilobites in the Ordovician; with marine crustacea in the Silurian; with oceanic fishes in the Devonian, and with land and fresh-water plants and animals in the coal measures. Their structure shows that they must have been marine and good swimmers; but toward the end of their race they became gradually adapted to brackish and even fresh water. The latest review of the group is in Eastman's American edition of Zittell's 'Text-book of Palaeontology' (1900).

**EURYSTHENES** (ū-rīs'thē-nēz) AND **PROCLE**, prō'clēz, the twin sons of Aristodemus, and the progenitors of the two royal lines of Sparta, which consisted of 31 sovereigns.

**EURYSTHEUS**, ū-rīs'thūs, the son of Sthenelus, and king of Mycenæ, who, at Juno's instigation, ordered Hercules to perform "the twelve labors." Hyllus, the son of Hercules, afterward killed him.

**EURYTHMICS**. See **DALCROZE**, EMILE JACQUES.

**EUSDEN**, ūs'dēn, Laurence, English poet: b. Spofforth, Yorkshire, 6 Sept. 1688; d. Coningsby, Lincolnshire, 27 Sept. 1730. He attracted much attention by his 'Original Poems' (1714); 'Ode for the New Year' (1720), and other poems. His appointment as poet laureate in 1718 was due to a fulsome poem on the marriage of the Duke of Newcastle, in whose gift the office lay, and was the occasion of much ridicule.

**EUSEBIUS** (ū-sē'bī-ūs) OF **CÆSAREA**, surnamed Pamphili, Church historian: b. probably Cæsarea, Palestine, 264 A.D.; d. there, about 349. He is known as Eusebius Cæsariensis and Eusebius Pamphili, that is, Pamphilus's Eusebius—a style assumed after the martyrdom of his instructor, Saint Pamphilus. He was chosen bishop of Cæsarea 314. He took a prominent part in the Council of Nicæa (325), and was present at the Synods of Antioch (330) and Tyre (335). With the exception of Origen and Jerome he was the most learned of the fathers, and is regarded as the father of ecclesiastical history. His moderation procured him the favor of Constantine, who declared him fitted to be the bishop of the whole world. Though he never subscribed to the views held by Arius and the Arians regarding the Godhead of Christ, he being averse to discussing the nature of the Trinity, was always friendly toward them and thus incurred censure as being at best a semi-Arian. Before the rise of Arianism he wrote a spirited defense of the Christian faith in refutation of a book by one Hierocles, who contended that the noted impostor, Apollonius of Tyana, was superior to Jesus Christ in sanctity and in miraculous powers. Eusebius wrote two treatises which have come down to our time: (1) the 'Preparation,' and (2) the 'Demonstration of the Gospel,' usually designated by their Latin titles, 'Præparatio Evangelica,' 'Demonstratio Evangelica.' The argument of the former is the groundlessness of idolatry, the impostures of the oracles, the monstrous impieties of the

heathen mythology and theology; and the author shows that the doctrine of the unity of the Godhead and the truth of his revealed religion is as ancient as the world. In the 'Demonstratio' the argument is that the law and the prophecies of the Jewish scriptures clearly foreshow Jesus Christ and the Gospel. Of his other works extant the chief is his 'History of the Church from the Time of Its Founder to the year 323.' It has the defect that in it no mention is made of the wickedness or dissensions of Christians as not being edifying to the faithful. See Schöne, 'Die Weltchronik des Eusebius in ihrer Bearbeitung durch Hieronymus' (1900).

**EUSEBIUS OF EMESA**, Greek ecclesiastic: b. Edessa; d. Antioch about 360. He studied under Eusebius of Cæsarea, and at Alexandria and Antioch. Averse to all theological controversies he declined the bishopric of Alexandria vacant by the deposition of Athanasius. He was afterward, however, appointed bishop of Emesa, in Syria, but was twice driven away by his flock, who accused him of sorcery on account of his astronomical studies. The homilies extant under his name are probably spurious.

**EUSEBIUS EMMERAN**. See DAUMER, GEORG FRIEDRICH.

**EUSEBIUS OF NICOMEDIA**, Arian bishop: d. Constantinople 342. He was appointed bishop of Beryta (Beirut) in Syria and afterward of Nicomedia. He appeared as the defender of Arius at the Council of Nice and afterward placed himself at the head of the Arian party. He baptized the Emperor Constantine in 337, and became patriarch of Constantinople in 339.

**EUSKALDUN**, ū'skäl-dön. See BASQUES.

**EUSKIRCHEN**, ois'kir-kën, Prussia, town and capital of a circle in the Rhine province, 15 miles west of Bonn. It has manufactories of cloth, furniture, leather, machinery, flour, meal, pottery, malt and beer. Pop. 12,413.

**EUSPORANGIATES**, ū'spō-rän'jī-á'téz, plants in which the sporangia occur beneath the body surface and not on the surface. The class includes all the seed plants and most of the Pteridophytes.

**EUSTACHIAN** (ū-stá'kīan) **TUBE**, in anatomy, a canal leading from the pharynx to the tympanum of the ear; named for the Italian anatomist, Eustachio. See EAR.

**EUSTACHIO**, ā-oos-tá'kē-ō, Bartolomeo, Italian anatomist: b. San Severino, c. 1500; d. Fossombrone, August 1574. He studied at Rome and became professor of medicine at the Studeo della sapienza there and was also pensioned physician. He later became physician to Cardinal Peretti, who thereafter became Pope Sixtus V. Although Eustachio at first took the part of Galen against Vesalius, he advanced the science of anatomy very considerably and thoroughly understood the importance of comparative and pathological anatomy. He later came to appreciate the work of Vesalius. The eustachian tube to the middle ear and the eustachian valve of the foetal heart perpetuate his name. He investigated the structure of the kidneys, the teeth, the ossicles of the ear, the zygous vein, the ductus

thoracicus, the valve of the vena cava inferior, the orarial nerves, the muscles of the head and neck and the valves of the coronary veins. He published 'De Renibus Liber' (Venice 1563); 'De Dentibus Liber' (Venice 1563); 'Opuscula Anatomica' (Venice 1564); 'Tabulæ Anatomicae' (Rouen 1714).

**EUSTACHIUS**, ū-stá'kī-ūs, or **EUSTATHIUS**, Roman martyr of the 2d century. At first named Placidus, after his conversion to Christianity he took the name of Eustachius. It is told that while hunting he beheld Christ between the antlers of a deer. He is regarded as the patron of hunters and suffered martyrdom under the Emperor Hadrian. In the Roman Catholic Church he is commemorated on 20 September.

**EUSTATHIUS**, semi-Arian bishop of Sebaste: b. about 300; d. 380. He introduced monasticism in Armenia and the celibate Eustathian order named from him were condemned at the Gangra Synod in 340. At Sebaste he founded a hospital for the poor. His doctrinal views brought him into continual conflict with his more orthodox contemporaries, but his intimacy with Constantine enabled him to retain his see. In 358 he was deposed by the Synod of Melitene. Consult Loofs, 'Eustathius von Sebaste' (Halle 1898).

**EUSTATHIUS**, Byzantine commentator: b. probably at Constantinople, early in the 12th century; d. 1194. He became a member of a monastic order, was made deacon of Holy Wisdom (Hagia Sophia) and in 1175 was made archbishop of Thessalonica. His principal work is the commentary on the 'Iliad' and 'Odyssey,' still a valuable source of information on ancient learning. In 1542 the commentary was first published in Rome; the latest edition is that of Stallbaum (7 vols., Leipzig 1825-30). He also wrote a commentary on Dionysius the Periegete, valuable for the fragments of Stephanus of Byzantium and Arrianus, which it has preserved to us. Consult the edition of Dionysius by Bernhardt (Leipzig 1828). He also wrote a commentary on Pindar of which the introduction only survives. He also left a great number of historical pamphlets, tracts and speeches; these are nearly all found in Migne, 'Patrologia Græca' (Vols. CXXXV, CXXXVI). Consult Krumbacher, 'Byzantinische Literaturgeschichte' (Munich 1897) and Pauly-Wissowa, 'Real-Encyclopädie der classischen Altertumswissenschaft' (Vol. VI, Stuttgart 1909).

**EUSTATIUS**, Saint, one of the Leeward Islands. See SAINT EUSTATIUS.

**EUSTIS**, James Biddle, American diplomatist: b. New Orleans, La., 27 Aug. 1834; d. Newport, R. I., 9 Sept. 1899. He was admitted to the bar in 1856 and practised in New Orleans till the Civil War broke out. He then entered the Confederate army and served as judge-advocate on the staffs of Gens. Magruder and J. E. Johnston till the close of the war. He was elected United States senator in 1876, but not given his seat till late in 1877; and was professor of civil law in the University of Louisiana in 1879-84, when he again served as senator, 1885-91. In March 1893 he was appointed United States Minister to France, and on the expiration of his term, in 1897, resumed

practice in New York. He translated into English the 'Institutes of Justinian,' and Guizot's 'History of Civilization.'

**EUSTIS, William**, American physician and politician: b. Cambridge, Mass., 10 June 1753; d. Boston, 6 Feb. 1825. He served as a surgeon in the American army during the Revolution, and subsequently practised medicine in Boston. He was a member of Congress 1801-05 and 1819-23; was Secretary of War 1809-13; and governor of Massachusetts in 1823-25.

**EUTAW**, ū'tā, Ala., town, county-seat of Greene County; on the Alabama Great Southern Railroad, about 95 miles southwest of Birmingham. It was settled in 1838, named in honor of the battle of Eutaw Springs, S. C. (1781), where the American forces commanded by General Greene gained a victory. It is in a rich agricultural region. It has an oil mill, ginneries, a lumber mill and a cotton compress. Pop. 1,000.

**EUTAW SPRINGS**, a small tributary of the Santee River in Charleston County, S. C. It is noted for the battle fought on its banks in 1781. See **EUTAW SPRINGS, BATTLE OF**.

**EUTAW SPRINGS, Battle of**, 8 Sept. 1781, in the Revolution. Tactically a drawn battle, in results it was an important American victory, winning the object of Greene's campaign, as the British shortly abandoned interior South Carolina, retiring to Charleston. Greene, having captured 96 men, stole on the British, some 2,500, under General Stuart, at Eutaw, 50 miles northwest of Charleston, and attacked suddenly at 4 A.M. He had about 2,000 men, part militia, but with Marion and Pickens for commanders; while the regulars were the famous Marylanders under Howard and Hardman, Virginians under Campbell, North Carolinians under Sumner, and the remnant of the brave Delaware men; with William Washington, R. H. Lee and Pleasant Henderson for cavalry leaders. The British had one line; the right on Eutaw Creek, the left in the air. The Americans had two, besides the reserves; the militia in front, who fought desperately and fired in some cases 17 rounds before giving way. Then the regulars rushed forward and swept the British line off the field; but gaining their camp, stopped to plunder it, and though rallied, could not drive the British from the strong positions they had taken. In assailing a brick house, Greene's guns were captured and he lost many of his best men; and a charge of Colonel Washington's was repulsed and himself taken prisoner. Greene was obliged to retreat; but Stuart decamped in the night. The American loss was 408 regulars killed and wounded, militia probably at least 150; British, 453 killed and wounded, 257 missing.

**EUTERPE**, ū-tér'pē ("the well-pleasing"), one of the Muses, considered as presiding over lyric poetry. The invention of the flute is ascribed to her. She is usually represented as a virgin crowned with flowers, having a flute in her hand, or with various instruments about her. As her name denotes, she is the inspirer of pleasure. (See **MUSES**). In botany, *Euterpe* is a genus of palms found in South America and the West Indies, and embracing seven or eight species. Some specimens attain a height

of nearly 100 feet. The wood of *E. oleracea* is used for flooring. Its fruit, as also that of *E. edulis*, is edible; and the latter species furnishes assai (q.v.). Euterpe in astronomy is an asteroid (No. 27), discovered by Hind in 1853.

**EUTHANASIA**, ū-tha-nā'sī-ā, means, in Greek, being happy or opportune in the time of one's death. The correlative adjective is applied in Greek literature to a man who died for his country, and it has been translated by the Latin historian "felix opportunitate mortis." The term euthanasia has recently been employed by some scientific men in advocating the reasonableness of relieving the sufferings of those afflicted with incurable diseases by administering to them anæsthetics or narcotics in sufficient doses to prove fatal. But religion, law and medical ethics alike condemn all forms of self-destruction.

**EUTHERIA**, subclass of Mammalia, comprising all mammals except the monotremes. Consult 'Cambridge Natural History' (Vol. X, London 1902) and Gregory, 'The Orders of Mammals' (in Bulletin of the American Museum of Natural History, Vol. XXVII, New York 1910).

**EUTHYMIUS**, Bulgarian prelate and author of the late 14th century. He was a pupil of the patriarch, Theodosius, lived for a time as a monk at Mount Athos, but afterward withdrew to Tirnovo, the seat of the Bulgarian patriarch. He here directed a large monastic establishment and revised the Slavic liturgical books. In 1375 he was chosen patriarch. He preached against the Bogomiles and other heretical bodies. He wrote much on the lives of the saints, prominent churchmen and various pastoral epistles. His style was clearly Byzantine, as was his thought, syntax, etc. His school of religious literature for a long time held sway in Bulgaria, Russia, Rumania and Serbia.

**EUTING**, oi'ting, Julius, German Oriental scholar: b. Stuttgart, 1839; d. 1912. He was educated at Tübingen, Paris, London and Oxford. He was made librarian-in-chief at the Imperial University and Government Library at Strassburg, of which institution he became director in 1900. In 1909 he retired. He traveled extensively in the Orient and collected a great number of Semitic inscriptions, which he bequeathed to the University of Strassburg. He published 'Sechs Phönikische Inschriften aus Idalion' (1875); 'Beschreibung der Stadt Strassburg und des Münsters' (1881; 15th ed., 1909); 'Nabatäische Inschriften aus Arabien' (1885); 'Sinaitische Inschriften' (1891); 'Tagebuch einer Reise in Inner-Arabien' (1896); 'Mandaischer Diwan' (1904).

**EUTROPIUS**, Roman historian. He was secretary to Constantine at Constantinople and in 363 fought against the Persians. Little else is known of him beyond the fact that he was still living in 378 A.D. He wrote 'Breviarium ab Urbe Condita,' a compendium of Roman history down to the time of Valens. An enlarged edition was later issued by Paulus Diaconus, and at the time of the Renaissance the work was in three distinct forms—the two named above and a third interpolated copy. The *editio princeps* (Rome 1471) was printed



from the text of Paulus. Good modern editions are those of Droysen (Berlin 1879), of Ruehl (Leipzig 1887) and one with English notes by Hazzard (New York 1898). Consult Teuffel, 'Geschichte der römischen Litteratur' (Vol. III, 6th ed., Leipzig 1913).

**EUTYCHES**, ū'ti-kēz, heresiarch of the Eastern Church, who flourished in the 5th century. He was a priest and archimandrite or prior of a monastery in Constantinople; was the founder of the religious sect called after him Eutyrians, but also Monophysites, as believing that in Jesus Christ was but one nature, and that the divine nature. The Council of Ephesus (431) having declared that in Jesus Christ were united the divine and human natures. Eutyches was condemned as a heretic by a synod of bishops held in Constantinople 448, but the next year the "Robber Synod" of Ephesus, controlled by Dioscorus, patriarch of Alexandria, reversed that judgment. In 451 the General Council of Chalcedon annulled the decrees of the Robber Synod, excommunicated Eutyches and formulated the Catholic doctrine regarding the hypostatic union of the divine and human natures in Christ. Eutyches died in exile. His doctrine took fast root in Syria, Armenia, Mesopotamia, Egypt and Ethiopia, and in those countries the Monophysite (now known as Jacobite) churches are strong to this day. See **MONOPHYSITES**.

**EUTYCHIANISM**, u-tik'i-an-iz'm, in Christology, the monophysitism peculiar to Eutyches, an archimandrite, or abbot of a monastery, who lived near Constantinople during the 5th century A.D. Monophysitism designates the creed of those who in opposition to the Creed of Chalcedon maintain the single-nature in Christ, or that the human and the divine in Jesus Christ constitutes but one composite nature. In Eutychanism it is held that the divine and human person in Christ is so blended as to constitute *one nature*. Eutyches was seduced by the vehemence of his opposition to Nestorianism into an unorthodox view of the nature of Jesus Christ. Prior to his time the Nicene Fathers had pronounced on the relation of the Father to the Divine Logos but left within the limits of orthodoxy room for a difference as to the relation of the Logos to the human Christ. The Antiochene school dreaded lest the idea of humanity should be entirely merged in that of the Logos. Others, leaning toward the teachings of Alexandria, sought to avoid any contaminations of the Logos by the associations of humanity. These positions on dogma became intermingled with questions of ecclesiastical authority, the conflict of national ideals and the lower strife of personal rivalry.

It is usually alleged that Eutyches was the victim of his own zeal in opposition to Nestorius. Nestorius, a harsh, unpleasant man, intolerant of doctrinal eccentricities, other than his own, made it his peculiar mission to prevent mankind from assigning human attributes to God, and boldly took the consequences of his position.

Now in time Nestorius came into collision with Cyril, a member of the Alexandrian school. To Cyril, it seemed that the doctrine of the Incarnation of the Logos is impugned by any hesitation to assign the attributes of humanity to the divine Christ. And it was this

theological principle which was the cause, or at least the pretext, of Cyril's first attack on Nestorius. On the other side, the Antiochene school, well represented in Theodore of Mopsvestia, a learned man and a great commentator, and the teacher whether directly or indirectly of Nestorius,—held to the christology of Theodore. In it the union of the divine and human in the person of Jesus was moral rather than physical or dynamical, and Theodore carefully avoided the deduction that the relation of divine and human was similar in kind, though different in degree, in Christ and in his followers. And the actions of Christ and his qualities as man and particularly his birth, sufferings and death, were not, in the christology of the Antiochene school, to be attributed to God without a qualifying phrase. This was the doctrine which Nestorius carried to its logical and practical conclusion; a position which is summarized in his saying: "I cannot speak of God as being two or three months old!" And yet this is the view which the Alexandrians, with Cyril at their head, and Eutyches among its following, considered as virtually implying *two* Christs, one divine and the other human.

In the Monophysite controversy Eutyches is the main figure. He had opposed Nestorius; now he was himself accused of disseminating errors of an opposite kind from those of his opponent. His accuser, Euselius of Dorylæum, induced Flavian, the patriarch of Constantinople, to call Eutyches to account. The accusations made, the aged Eutyches was with difficulty brought from the seclusion of his monastery. He was no theologian; and wished to fall back on the decisions of Nicæa and of Ephesus. But the accusers pressed him, and the old man replied that he confessed Christ as being of two natures *before* the union in the Incarnation, of one nature *afterward*, being God Incarnate! On this point he would not recant: it was his peculiar monophysitism. How he appealed to the emperor, to Pope Leo and to the monks of Constantinople; how the decision of the Patriarch Flavian to excommunicate Eutyches was controverted by the Council of Ephesus in 449; and how in Chalcedon, two years later, Eutychanism was condemned a second time, and the received doctrine came into existence; all this is without the limits of this article. In place of the Monophysite doctrine of the one nature, it was established at Chalcedon that Christ was perfect God and perfect man, consubstantial with the Father as to his divinity, and with man as to his humanity, the two natures being united with him, without conversion, without confusion and without division. But if the Council of Chalcedon had succeeded in pronouncing Eutyches a heretic, it did not stamp out the influence of his doctrine. The sect of the Eutyrians continued quietly to grow for a century after his death in the churches of Armenia, Ethiopia and of the Copts. And soon after his condemnation, 10 different sects could be counted who shared his teachings among themselves. Thus it came about that his heresy got for itself the name "ten-horned."

Monophysites still exist in Egypt and the East, under the title of Jacobites, a name derived from Jacob Baradaeus. From them the orthodox are distinguished by the name of Melchites, or Royalists, which title they have

owing to their adherence to the edicts of the Emperor Marcian, in favor of the Council of Chalcedon, and their adoption of the doctrine it laid down. (See MONOPHYTES). Consult Harnack, 'History of Dogma'; and Ottley, R. L., 'The Doctrine of the Incarnation.'

**EUTYCHIANUS**, ū-tik'i-ā'nūs, Saint, the 27th Pope and bishop of Rome. He reigned from 275 to 283. He is commemorated on 8 December.

**EUTYCHIDES**, Greek sculptor of the 4th century B.C. He was a native of Megara and a pupil of Lysippus. For the city of Antioch he executed a statue of Fortune, which made him famous. Many copies of it were made throughout the Orient and a small copy now rests in the Vatican Museum. Some authorities hold that the 'Victory of Samothrace' is his work, but of this there is no conclusive proof.

**EUXANTHIC** (ūk-săn'thik) **ACID** (C<sub>12</sub>H<sub>10</sub>O<sub>10</sub>), called also **PURREIC ACID**, an acid obtained from purree, or Indian yellow. With the alkalis and earths, it forms soluble yellow compounds.

**EUXENITE**, ūk'sē-nīt, a rare Norwegian mineral, essentially a niobate and titanate of yttrium, erbium, cerium and aurantium. It sometimes contains iron calcium and germanium, while water is always present. It occurs in orthorhombic crystals, but usually it is massive. It has a hardness of 6.5, a specific gravity of 4.7 to 5.0, a brilliant metallic-vitreous lustre, and a brownish-black color, showing a reddish-brown translucence in thin slivers.

**EUXINE**, ūk'sin, the ancient name for the Black Sea.

**EVA**, Little, a beautiful child, who becomes the friend and consoler of Uncle Tom in Harriet Beecher Stowe's novel 'Uncle Tom's Cabin.' Her early death forms one of the climaxes of that affecting story.

**EVACUATION HOSPITALS**. See HOSPITALS, MILITARY.

**EVADNE**, e-vād'nē, in Greek fable, the daughter of Iphis of Argos, who threw herself into the funeral pile of her husband, Cateneus.

**EVAGORAS**, e-väg'ō-ras, king of Salamis in Cyprus, flourished about the beginning of the 4th century B.C. His family had been expelled by a Phœnician exile. Evagoras recovered the kingdom in 410 B.C., and endeavored to restore in it the Hellenic customs and civilization. He was friendly with the Athenians, and in return for his services a statue was erected to him at Athens. His increasing power attracted the jealousy of the Persian king, Artaxerxes II, who declared war against him and besieged Evagoras in his capital. He was saved only by the dissensions of his enemies, and was able to conclude in 387 a peace by which the sovereignty of Salamis was nominally at least secured to him. He was assassinated 374 B.C.

**EVAGRIUS** (e-väg'rī-ūs) **SCHOLASTICUS**, Syrian Church historian: b. Epiphonia, about 536; d. after 594. He wrote the history of the Church in continuation of the ecclesiastical histories of Eusebius, Socrates, Theodoret and Sozomen from 431, the date of

the Council of Ephesus, to 594. His surname, Scholasticus, indicates that he was by profession (probably at Antioch) an advocate, for such at that time was a usual meaning of the word: he was legal adviser to Gregory, patriarch of Antioch, who commended him for his fidelity and learning to the emperor, Tiberius Absimarus, and obtained his promotion to a judicial office. In recognition of his eminent integrity as an official of the empire his second marriage was made the occasion of a public festival; which, however, had a disastrous ending, for it was interrupted by a violent earthquake, which caused the loss of thousands of lives.

**EVALD**, ä'vält. See EWALD, G. H. A.

**EVALD**, ä'väld, Herman Frederik, Danish novelist: b. 1821; d. 1908. His works deal mostly with history and are of considerable merit. They include 'Valdemar Krone's Youth' (1860); 'The Nordby Family' (1862); 'Johannes Falk' (1865); 'Charles Lyng' (1882); 'The Swedes at Kronborg' (1867); 'Anna Hardenberg' (1880); 'Clara Bille' (1892); 'Leonore Kristine' (1895); 'Klein Kirsten' (1901); 'Bondebruden' (1904).

**EVALD**, Johannes, Danish lyrical poet: b. Copenhagen, 1743; d. 1781. In 1764 appeared his 'Temple of Fortune,' followed two years later by 'Elegies' on the death of Frederick V. These works brought him fame, which was further established by the biblical drama, 'Adam and Eve,' in 1769. His 'Rolf Krake,' which appeared in 1770, was the first original tragedy in the Danish language. From 1770 to 1780 he wrote tragedies, comedies and farces, including 'The Fishers,' his greatest work, in which appeared the present Danish national anthem. Evald's health had been seriously impaired through overwork and the strain incident to the production of 'The Fishers' hastened the end. His works were edited by Liebenberg (8 vols., Copenhagen 1855). Consult his 'Life and Opinions' (Copenhagen 1792); and the lives by Hammerich (ib. 1882) and Jorgensen (ib. 1888).

**EVANDER**, in classical legend, the civilizer of Latium, the son, according to one account, of Hermes and an Arcadian nymph. About 60 years before the Trojan War he established himself in Latium and built, at the foot of the Palatine Hill on the banks of the Tiber, a town, to which he gave the name of Pallantium. The Roman legends represent him as teaching the Latins the use of the alphabet and the arts of agriculture and music, softening their fierce manners by the introduction of more humane laws, and introducing among them the worship of the Lycaean Pan, Heracles, Demeter, etc. In the Æneid Virgil brings his hero Æneas into connection with Evander, who gave him a favorable reception, and becomes his ally against the Latins. Divine honors were paid to Evander by the inhabitants of Pallantium in Arcadia.

**EVANGELICAL**, a word literally signifying "pertaining to the gospel" and used in different senses. In one of its senses it is a term used to qualify certain doctrinal opinions, stress being laid on the total depravity of human nature, need of conversion, justification by faith, free offer of the gospel, the plenary inspiration and exclusive authority of the Bible.

In this sense the word, when applied to a whole church, is in Scotland almost synonymous with orthodox; and in the United States it has much the same significance, in contrast to the words "liberal" and "rationalistic." In England the Evangelical or Low Church party is looked upon as extreme in its views, and is distinguished from the orthodox party, which holds the doctrines above specified in a more modern form. When used in a less general sense something more is implied in the word. It indicates peculiar attachment to sound doctrine and peculiar fervency in advocating it. In another sense the term is applied in Germany to Protestants as distinguished from Roman Catholics, inasmuch as the former recognize no standard of faith except the writings of the evangelists and the other books of the Bible, and more especially to the national Protestant Church, formed in Prussia in 1817, by a union of the Lutheran and Calvinistic churches.

**EVANGELICAL ALLIANCE**, a voluntary association of members of the different sections of the Christian Church, organized in London 19-23 Aug. 1846. At this meeting was adopted a doctrinal basis, which is, in effect, the recognition by the members of the divine inspiration, authority and sufficiency of the Holy Scriptures; the right of private judgment in their interpretation; the unity of the Godhead and the Trinity of persons therein; the doctrine of human depravity in consequence of the fall; the incarnation, atonement, intercession and mediatorial reign of the Son of God; justification by faith alone; the work of the Holy Spirit in conversion and sanctification; the immortality of the soul, the resurrection of the body and the final judgment of the world, resulting in the eternal blessedness of the righteous and the eternal punishment of the wicked; the divine institution of the Christian ministry; and the obligation and perpetuation of the ordinances of baptism and the Lord's Supper. The organization thus commenced has since been extended throughout Protestant Christendom. Branch alliances have been formed in Great Britain, Germany, France, Switzerland, Sweden, the United States, Australia, and among missionaries in Turkey, India, Brazil and Japan. These national branches are related to each other as members of a confederation having equal rights. The whole alliance appears in active operation only when it meets in general conferences having the character of Protestant ecumenical councils, but claiming only moral and spiritual power. The American branch of the alliance was organized in 1867. Conferences of the entire alliance have been held in 1851, 1855, 1857, 1861, 1867, 1873, 1879, 1885, 1891, 1896, 1907, that of 1873 having met in New York. The American branch held a conference at Chicago in October 1893. The alliance has aided largely in the promotion of religious liberty in Europe and the East. Consult 'Reports' of the conferences; and Arnold, 'History of the Evangelical Alliance' (London 1897).

**EVANGELICAL ASSOCIATION**, a religious denomination founded in Pennsylvania about the beginning of the 19th century by Jacob Albright, a member of the Methodist Episcopal Church, who was born in Pennsylvania 1759, and from about 1790 traveled among the German population as an evangelist. Al-

bright founded a society of converts in 1800, which so increased in numbers that it was finally organized in 1807 as the Evangelical Association of North America, with Albright as bishop. The theology of the association as defined in its 21 articles closely resembles that of the Methodist Episcopal Church, from which, also, it differs little in government and form of worship. The Church was divided in 1891, when a minority, numbering 40,000, organized the United Evangelical Church. In 1916 the association had 27 annual conferences, including one in Japan, one in Switzerland, and two in Germany; 1,663 preachers, 115,243 communicants, and property valued at about \$11,000,000. Besides its German elements it has a relatively large English-speaking membership and publishes English periodicals and English books. It has four bishops, a well-equipped publishing house at Cleveland and another at Stuttgart, Württemberg; a biblical institute and North-western College at Naperville, Ill.; two seminaries; an orphan home at Flat Rock, Ohio; a charitable society; a missionary society, sustaining domestic and foreign missions in Japan and China and assisting the European churches; a Woman's Missionary Society; a Church Extension Society. Hospitals are maintained in various cities in Germany, and in Chicago and in Bismarck, N. Dak. Its periodicals are *The Evangelical Messenger* (weekly); *The Missionary Messenger* (monthly); *Der Christliche Botschafter* (weekly). Consult Plitt, 'Die Albrechtsleute' (Erlangen 1877); Carroll, 'Religious Forces of the United States' (New York 1912); Orwig, 'History of the Evangelical Association' (1858).

**EVANGELICAL CHURCH, The United.**  
See UNITED EVANGELICAL CHURCH, THE.

**EVANGELICAL CHURCH CONFERENCE**, the name of the general meetings of representatives of the Protestant bodies of Germany and Austria. The first general conference met at Berlin in 1846 and was followed by the Eisenach Conference of 1852. Since 1854 these conferences have been held every two years at Eisenach. The object is the promotion of unity among the several evangelical bodies which send representatives to the conference. The official organ, *Allgemeines Kirchenblatt für das evangelische Deutschland*, is issued regularly at Stuttgart. Consult Braun, 'Zur Frage der engeren Vereinigung der Deutschen evangelischen Landeskirchen' (Berlin 1902).

**EVANGELICAL COUNSELS**, in Catholic theology, are distinguished from divine commandments in this, that the commandments are of universal obligation for whoever would be saved, while the Evangelical Counsels point to the readiest and surest means of attaining that end. When a certain ruler put to Jesus Christ the question "What good thing shall I do that I may inherit life?" and received the answer "If thou wilt enter into life, keep the commandments," he was taught the condition of salvation which applies to all mankind. But he wanted to know whether there is not a more excellent way: he had "observed all those things from his youth up"; was there not some other "good thing" for him to do? Then Jesus prescribed to him the perfect way: "Sell all that thou hast and distribute unto the poor" (Matt. xix, 21),

giving him one of the Evangelical Counsels, the counsel of voluntary poverty. The celibate life is commended by Saint Paul as more favorable to entire devotion to the service of God than the state of marriage; that Evangelical Counsel is the principal topic of the epistle of 1 Corinthians. Finally, entire obedience is the third of those counsels—renunciation of self-will, cheerful submission to the rule of superiors. Members of the religious orders of the Catholic Church bind themselves by solemn vows to practise the three Evangelical Counsels: poverty, chastity and obedience.

**EVANGELICAL UNION**, the name of a religious body, also familiarly known as the Morisonians, from the Rev. James Morison, of Kilmarnock, by whom, with three other clergymen, it was founded in Scotland in 1843. The founders were soon joined by a number of ministers and churches of the Congregational Union of Scotland, and extended themselves considerably in Scotland and the north of England. The Morisonians maintain the universality of the atonement, combining with this the doctrine of eternal personal and unconditional election. In point of church government the members of the Evangelical Union are independent, but many congregations have ruling elders. In 1896 nearly all the churches were absorbed by the Congregational Union. The body had in 1899 between 90 and 100 congregations, chiefly in Scotland, and 712 ministers. Consult Ferguson, 'History of the Evangelical Union' (1876); and Adamson, 'Life of Dr. James Morison' (London 1898).

**EVANGELINE.** 'Evangeline: a Tale of Acadie' is based upon a true story which traveled from Canada to New England by word of mouth, reached Hawthorne, who did not care to use it for a romance, and was by him turned over to Longfellow, who published his poem in 1847. It instantly won the widest public, and has ever since remained among the most popular narrative poems in the English language. Hawthorne's disinclination to use the incident was probably due to the fact that he did not find it deeply tragic: the fate of the innocent lovers who are separated by a purely external force but who remain faithful till death is hardly more than pathetic. The tenderness, however, with which Longfellow handled the pathos of the theme quite conceivably appealed to a larger variety of readers than a stern tragic handling, such as Hawthorne's might have been. In form the poem follows the example set by J. H. Voss's 'Luise' (1795) and the greater 'Hermann und Dorothea' (1798) of Goethe, both of which had attempted to treat modern sentiments and manners with Homeric simplicity. But 'Evangeline' owes nothing essential to its predecessors. The hexameters in which the story is told, while not so close to classical hexameters as those of A. H. Clough's 'Bothie of Tober-na-Vuolich' (1848) or Kingsley's 'Andromeda' (1858), added to English poetry, never before or since hospitable to the measure, a new rhythm. The language of 'Evangeline,' while rarely vivid, is pure, sweet and melodious; its landscapes, though full of charm and color, like its characters, resemble its characters also in belonging less to any particular soil than to

the general world of romance. Still, in spite of its lack of raciness and actuality, the poem founded a national legend which has kept alive the memory of an episode that would otherwise have been forgotten; and by something universal in its gracious manner has increased modern literature with a story everywhere read and remembered.

CARL VAN DOREN.

**EVANGELIST** (a bringer of good tidings), in the New Testament, a preacher of the gospel, distinguished (Eph. iv, 11) from the apostles, prophets, pastors and teachers. The term came ultimately to refer to only the authors of the four Gospels, but in modern times has been extended to indicate also an unattached preacher whose specific work is the arousing of personal interest in matters of religion.

**EVANGELISTARION**, a book of selections from the Gospels, used as a service book in the Greek Church. It contains the Gospel lessons for each day in the year. The book which contained the lessons from the Acts and Epistles was called the Praxapostolos. If both were included in a single work, the latter was termed a Euxologia. There are hundreds of manuscripts of these service books in existence, dating from the 6th century onward. Consult Gregory, C. R., 'The Canon and Text of the New Testament' (New York 1907) and Scrivener, 'Introduction to the Textual Criticism of the New Testament' (4th ed., London 1894).

**EVANGELISTS, Symbols of the Four.** These symbols take their origin from Irenæus, who identified the four living creatures before the throne of God (Rev. iv, 64) with the four Evangelists. For a long time there was little agreement as to the order in which the creatures were assigned to each Evangelist. Later in the Western Church the following order became general: the man represents Saint Matthew; the lion, Saint Mark; the calf, Saint Luke; and the eagle, Saint John. Consult Goldsmith, E. E., 'Sacred Symbols in Art' (New York 1911) and Jenner, Mrs. Henry, 'Christian Symbolism' (Chicago 1910).

**EVANS, Alexander William**, American botanist: b. Buffalo, N. Y., 17 May 1868. He was graduated at Yale in 1890 and in 1894-95 studied at Munich and Berlin. In 1895 he began his connection with the botanical department of Yale, becoming professor of botany there in 1906. He is an ex-president of the Botanical Society of America. He has made extensive investigations of the bryophytes of Connecticut and the hepaticæ of Alaska. He is a Fellow of the American Association for the Advancement of Science.

**EVANS, SIR Arthur (John)**, English archæologist: b. Nash Mills, Hertfordshire, 1851. He is a son of Sir John Evans (q.v.). He was educated at Harrow, Oxford, and Göttingen, and was keeper of the Ashmolean Museum, Oxford, from 1884 to 1908. Since 1893 he has superintended archæological researches in Crete, excavating in 1900-08 the prehistoric palace of Knossos. He has published 'Through Bosnia' (1895); 'Illyrian Letters'; 'Antiquarian Researches in Illyricum' (1883-

85); 'Cretan Pictographs and Præ-Phœnician Script' (1896); 'Further Discoveries of Cretan and Ægean Script' (1896); 'The Mycenaean Tree and Pillar Cult' (1901), etc. He was knighted in 1911.

**EVANS, Augusta Jane.** See WILSON, AUGUSTA JANE EVANS.

**EVANS, Christmas,** Welsh Baptist divine: b. Isgaerwen, Cardiganshire, 25 Dec. 1766; d. Swansea, 19 July 1838. He was at first a Presbyterian but joined the Baptists in 1788, and in the following year was ordained a missionary among the Baptists of Carnavonshire. After three or four years there he removed to Anglesey where he lived until 1826. In Anglesey he practically exercised episcopal functions and his removal to Glamorganshire in 1826 was occasioned by his arbitrary conduct. He removed to Cardiff in 1828 and four years later to Carnarvon. He was an able and eloquent preacher and was well known throughout Wales where he did much in behalf of church building. Consult the biography by Hood (London 1881).

**EVANS, Edward Payson,** American author: b. Remsen, N. Y., 8 Dec. 1831. He graduated at the University of Michigan in 1854, where, after several years of teaching in Mississippi and Wisconsin, he was professor of modern languages and literatures in 1862-67. He has made a special study of Oriental languages; in 1884 became connected with the 'Allgemeine Zeitung,' of Munich in Europe, to which he contributed many articles on the literary, artistic and intellectual life of the United States. He has published 'Summary of the History of German Literature' (1869); 'Progressive German Reader' (1870); 'Animal Symbolism in Ecclesiastical Architecture' (1896); 'Evolutional Ethics and Animal Psychology' (1898); 'Beiträge zur Amerikanischen Litteratur und Kulturgeschichte' (2 vols., 1898-1903); 'The Criminal Prosecution and Capital Punishment of Animals' (1906).

**EVANS, Edward Radcliffe Garth Russell,** English explorer and naval officer: b. 1881. He was educated at Merchant Taylors' School and entered the navy in 1897, becoming sub-lieutenant in 1900. He served on the *Morning*, the relief ship to the *Discovery* expedition in 1902-04. In 1907 he was awarded the Shadwell Testimonial Prize by the Lords Commissioners of the Admiralty. In October 1909 he joined the British Antarctic Expedition as second in command, and was made commander in 1912. He returned in command of the expedition after the death of Captain Scott. He lectured on the Scott expedition in the United States in 1914, commanded the *Mohawk* in the bombardment of the right wing of the German army on the Belgian coast in 1914. In this year he received the cross of the Legion of Honor, was made C.B. in 1913 and received the D.S.O. in 1917.

**EVANS, Elizabeth Edson Gibson,** American prose writer: b. Newport, N. H., 8 March 1832; d. 10 Sept. 1911. She was married to Edward Payson Evans (q.v.) 1868. She has published 'The Abuse of Maternity' (1875); 'Laura, an American Girl' (1884); 'A History of Religions' (1892); 'Story of Kasper

Hauser' (1892); 'The Story of Louis XVII of France' (1893); 'Transplanted Manners' (1895); 'Confession' (1895); 'Ferdinand Lalsalle and Helen von Dönninger' (1897); 'The Christ Myth' (1901).

**EVANS, Evan Heber,** Welsh Congregational clergyman: b. near Newcastle, Cardiganshire, 1836; d. Bangor, 1896. He received his education at Swansea Normal College and Brecon Memorial College. In 1862-65 he was pastor of Lebanus Church, Morriston, and from 1865 to 1894 of Salem Church, Carnarvon. In 1886 he served as clergyman of the Welsh Congregational Union and in 1892 of the Congregational Union of England and Wales. In 1894 he was appointed head of the Bangor Congregational College. He edited the Welsh Congregational magazine, *Y Dysgedydd*. Consult the biography by H. Elvet Lewis.

**EVANS, Frederick William,** American writer: b. Bromyard or Leominster, England, 9 June 1808; d. Mount Lebanon, N. Y., 6 March 1893. He removed to the United States in 1820; joined the United Society of Believers (Shakers) at Mount Lebanon, N. Y., in 1830, and became a recognized leader in that society. The best known of his works are 'Compendium of the Origin, History, and Doctrines of the Shakers' (1859); 'Autobiography of a Shaker' (1869); 'Shaker Communism' (1871); 'The Second Appearing of Christ' (1873).

**EVANS, Sir George de Lacy,** British general: b. Moig, Ireland, 1787; d. London, 9 Jan. 1870. He entered the army in 1806, took part in the later stages of the Peninsular War and in the beginning of 1814 was sent to America, and at the battle of Bladensburg (24 Aug. 1814) had two horses shot under him. At the head of 200 men he forced the capitol at Washington. He was present at the attack on Baltimore, and was twice wounded before New Orleans in December 1814, and was on that account sent home to England, where he recovered just in time to be able to join Wellington at Quatre-Bras and Waterloo. He served with distinction on the side of the queen regent in the Carlist War of 1835-37. In 1846 he was raised to the rank of major-general. At the outbreak of the Crimean War he was appointed to the command of the second division of the British army, and distinguished himself at the battle of the Alma, the siege of Sebastopol and the battle of Inkerman. He was made a general in 1861. He served as a Liberal member in the House of Commons between 1831-65, but not continuously.

**EVANS, George Essex,** Australian poet: b. London, 18 June 1863. He went to Australia in 1881 where he eventually became district registrar at Toowoonyb, Queensland. He has written extensively for the Australian press. He was editor of the *Antipodean* (1893-97); and he won the 50 guinea prize offered by the government of New South Wales for the best ode on the inauguration of the Commonwealth in 1901. He was founder of the Astral Association for the Advancement of Music, Art, Literature and Science' (1901). Among his published works are 'Madeline Despar and Other Poems' (London 1891); 'Lorraine and Other Verses' (Melbourne 1898); 'The Garden of Queensland' (1898); 'The Secret Key and

Other Verses' (Sidney 1906). The greater part of his work, most of which has been contributed to magazines and newspapers, has not been published in book form.

**EVANS, Henry Clay**, American politician: b. Juniata County, Pa., 18 June 1843. He served in the 51st Wisconsin Infantry, enlisting 1864, and subsequently settled in Chattanooga, Tenn., as an iron and railway-car manufacturer, and was mayor of Chattanooga for two terms. He sat in Congress in 1889-91, and was assistant Postmaster-General 1889-93. His election as governor of Tennessee 1894 was disputed and the opposing Democratic candidate was seated. He stood second in the vote for Vice-President at the National Republican Convention 1896, was appointed United States Commissioner of Pensions in 1897, and was consul-general in London from 1902 to 1905. He is now commissioner of education and health of the city of Chattanooga under the commission form of government.

**EVANS, Hugh Davy**, American author: b. Baltimore, Md., 26 April 1792; d. there, 16 July 1868. He studied law, began practice in Baltimore in 1815 and became eminent as a jurist. He was editor of *The True Catholic* 1843-56, and was connected with various other papers. He was a prominent member of the Maryland Colonization Society, and prepared a code of laws for the Maryland colony in Liberia; and in 1862-64 lectured on civil and ecclesiastical law. Among his writings are 'Essays on Pleading' (1827); 'Maryland Common-Law Practice' (1837); 'Theophilus Anglicanus' (1851); 'Essays on the Episcopate of the Protestant Episcopal Church in the United States' (1855); 'Treatise on the Christian Doctrine of Marriage' (1870). Consult memoir by Harrison (1870).

**EVANS, John**, American geologist: b. Portsmouth, N. H., 14 Feb. 1812; d. Washington, D. C., 13 April 1861. He served on several State and Territorial geological surveys, and discovered remarkable fossil deposits in the Bad Lands of Nebraska. He was afterward commissioned by the United States government to carry on the geological surveys of Washington and Oregon.

**EVANS, John**, American philanthropist: b. Waynesville, Ohio, 9 March 1814; d. Denver, Colo., 3 July 1897. He was graduated at the medical department of Cincinnati College in 1838; in 1848 became a professor in the Rush Medical College of Chicago, in which city he accumulated a large fortune by investments in real estate. Much of this he gave to philanthropic objects. He established the Northwestern University, and endowed two chairs in it with \$50,000 each. In 1862-65 he was governor of the Colorado Territory. Later he established the University of Denver, to the construction of which he gave \$200,000 and a large endowment. He gave largely for the erection of the Grace Methodist Episcopal Church in Denver, and aided almost every educational institution and Methodist Episcopal Church in the State.

**EVANS, SIR John**, English archæologist: b. Britwell Court, Buckinghamshire, 17 Nov. 1823; d. 31 May 1908. His publications include 'The Coins of Ancient Britons'; 'The Ancient Stone Implements, Weapons and Ornaments of Great Britain and Ireland' (1872); 'Ancient Bronze Implements, Weapons and Ornaments

of Great Britain and Ireland' (1881). From 1878 till 1896 Sir John was treasurer of the Royal Society, and he presided over the Toronto meeting of the British Association in 1897. He was president of the Geological Society (1874-76), of the Numismatic Society (1874-1906), and of the Society of Antiquaries (1885-92). His great work on stone implements received a prize from the French Academy, and both it and his other work on bronze implements were translated and published in Paris shortly after they appeared in England.

**EVANS, John Gwenogvryn**, Welsh scholar: b. Ffynnon Velved, Carmarthenshire, 1852. He was educated at Pontshan Grammar School, the Presbyterian College, Carmarthen, and Owens College, Oxford. He was editor of the 'Series of Old Welsh Texts,' was inspector of documents in the Welsh language for the Historical Manuscripts Commission from 1894 to 1906. He was nominated governor and member of the council of the University College of Wales, and governor and member of the council of the National Library of Wales by the lord president of the Privy Council. His publications include 'Homeward Bound' (1882); 'Red Book Mabinogion' (1887); 'Facsimile of the Black Book of Carmarthen' (1888); 'The Bruts' (1890); 'The Book of Llandav' (1893); 'Diplomatic Text, with Notes and Introductions, of the Black Book of Carmarthen' (1906); 'Editio Princeps of the White Book Mabinogion, and Romances from the Peniarth MSS.' (1907); 'Facsimile and Text of the Book of Aneirin' (1908); 'Facsimile of the Chirk Codex of the Welsh Laws' (1909); 'Facsimile and Text of the Book of Taliessen, with a revised text and translation into English' (1914).

**EVANS, Margaret J.** See HUNTINGTON, MARGARET EVANS.

**EVANS, Mary Ann, or Marian.** See ELIOT, GEORGE.

**EVANS, Oliver**, American inventor: b. Newport, Del., 1755; d. New York, 25 April 1819. In 1877 Evans invented a machine for making card-teeth. Two years later he entered into business with his brothers, who were millers, and in a short time invented the elevator, the conveyor, the drill, the hopper-boy, and the descender, the application of which two mills worked by water-power effected a revolution in the manufacture of flour. For some years after these improvements were perfected, the inventor found much difficulty in bringing them into use, although in his own mill the economy of time and labor which they effected was very manifest. About 1799 or 1800 he set about the construction of a steam-carriage; but finding that his steam engine differed in form as well as in principle from those in use, it occurred to him that it could be patented and applied to mills more profitably than to carriages; and in this he was completely successful. This was the first steam engine constructed on the high-pressure principle; and to Evans, who had conceived the idea of it in early life, and in 1787 and again in 1794-95 had sent to England drawings and specifications, the merit of the invention belongs, although it has been common to assign it to Vivian and Treve-thick, who had had access to Evans' plans. In 1803-04, by order of the board of health of

Philadelphia, he constructed the first steam dredging machine used in America, consisting of a flat scow with a small engine to work the machinery for raising the mud. Evans also invented the "Cornish boiler."

**EVANS, Robley Dungleison**, American naval officer: b. Floyd Court House, Va., 18 Aug. 1846; d. Washington, 3 Jan. 1912. He was appointed to the United States Naval Academy from Utah in 1860, promoted ensign in 1863, and in 1864-65 was on board the *Powhatan* of the North Atlantic blockading squadron. He participated in both attacks on Fort Fisher; in 1868 was commissioned lieutenant-commander, in 1870-71 was on duty at the navy yard, Washington, in 1871-72 at the Naval Academy. Having served in 1873-76 successively on the *Shenandoah* and the *Congress*, of the European station, he was made commander in 1878; in 1891-92 was in command of the *Yorktown* at Valparaiso, Chile, where American sailors were killed by a mob, and in 1893 became captain. He policed the Bering Sea sealing grounds. During the Spanish-American War he was in command of the *Iowa*, and at the naval battle of Santiago he took an important part in the destruction of Cervera's fleet. In 1901 he was commissioned rear-admiral; in 1902 was made commander of the Asiatic fleet with the flagship *Kentucky*; was escort to Prince Henry of Prussia, during the latter's visit to the United States; commanded the Atlantic fleet, 1905-07, taking it in 1907, as commander-in-chief, on tour of the world. After rounding Cape Horn, and on reaching San Francisco, ill health forced him to give up the command. He was retired 18 Aug. 1908. He published 'A Sailor's Log' (1901); and 'An Admiral's Log' (1910).

**EVANS, Thomas Williams**, American dentist: b. Philadelphia, 23 Dec. 1823; d. Paris, 14 Nov. 1896. He studied dentistry and practised in Maryland and later in Lancaster, Pa., and made a specialty of saving teeth by filling. In seeking a substitute for gold foil he mixed rubber and sulphur, which made a black substance instead of a white one. Because of the unfavorable color he laid the substance aside and gave it no more thought till his mixture was used by others for producing commercial gutta-percha, which he declared he had discovered. In 1848 he went by invitation to Paris, as the most skilful American dentist, to attend to the teeth of President Louis Napoleon. During his career in Paris he accumulated a very large fortune. He also won an international reputation as an expert in military sanitation, and was one of the founders of the Red Cross Society. His home was the refuge of the Empress Eugénie from the mob on the night of 4 Sept. 1870. Dressed in his wife's clothes, she was taken by him to the Normandy coast, where he secured her escape to England. He bequeathed all of his fortune, estimated at from \$8,000,000 to \$12,000,000, excepting \$250,000, to establish a museum and institute in Philadelphia.

**EVANSTON, Ill.**, city in Cook County, on the Chicago and Northwestern Railway, 12 miles north of Chicago on Lake Michigan. It has electric surface and elevated railroads to Chicago; Holly system of waterworks, with complete filtration plant, daily newspapers and three banks, deposits over \$6,000,000. It is the seat

of Northwestern University (M.E.) founded in 1854, largely endowed and of high repute, with a library of 25,000 volumes and a museum. It is the seat also of the Garrett Biblical Institute. The Dearborn Observatory was transferred here from Chicago in 1888. Evanston was the home of Frances Willard (q.v.). It is really a residential suburb of Chicago, and called "City of Churches." The Evanston Commercial Association—over 300 members—has much influence in civic and business affairs. Pop. 30,000.

**EVANSTON, Wyo.**, city and county-seat of Uinta County, 76 miles east of Ogden, on the Bear River and the Union Pacific Railway. There are valuable coal mines in the vicinity, and the surrounding region is also largely devoted to stock-farming and agriculture. Oil has been discovered in the neighborhood. Among the local industries are a large flouring-mill, ice plant and railway repair shops. The State Asylum for the Insane is situated here. The city contains a public library and owns the waterworks. Pop. 2,583.

**EVANSVILLE, Ind.**, a city and port of entry of Vanderburg County, of which it is the county-seat, about 185 miles west of Louisville, 192 miles northeast of Cairo, and 180 miles southwest of Indianapolis, on the Ohio River, and the Louisville, E. & St. L., the Louisville & N., the Evansville & T. H. and other railways. It is pleasantly located on a high bank of the river. Evansville is the chief shipping point for southwestern Indiana, and ranks highly among the commercial centres of the State. The neighboring region abounds in coal and the local coal trade is a large one. There is also an important trade in flour, pork, tobacco, grain and timber. There are machine-shops and foundries, plow-works, furniture factories, flouring-mills, and manufactures of cottons and woollens, brick and tile, pottery, terra-cotta and fire-clay products, malt liquors, and saddlery and harness. The United States census of manufactures for 1914 showed within the city limits 297 industrial establishments of factory grade, employing 11,698 persons; 10,333 being wage earners, receiving a total of \$5,168,000 annually in wages. The capital invested aggregated \$24,666,000, and the year's output was valued at \$31,427,000: of this, \$13,427,000 was the value added by manufacture.

The prominent buildings include the United States custom-house, the courthouse, the city hall, the Willard Library, the State Hospital for the Insane, Evans Temperance Hall, Citizen's National Bank Building and the United States Marine Hospital. There are also 10 parks. Daily and weekly newspapers are published. Evansville was founded by Gen. R. M. Evans in 1817, became the county-seat of Vanderburg County in 1819, and was incorporated in 1847. The government is administered by a charter of 3 March 1893, with amendments of 11 March 1895. This instrument provides for a mayor, elected for four years, and a common council, one member from each ward for one year and four councilmen at large for two years. The annual expenditure of the municipality is about \$700,000, the annual income about \$940,000. The municipality owns the waterworks, which are operated at a yearly expense of about \$30,000. Pop. 96,737.

**EVANSVILLE**, Wis., a village of Rock County, 17 miles northwest of Janesville and 22 miles south by east of Madison, on the Chicago and Northwestern Railway. Among its industries are an extensive wind-mill factory, an iron-foundry and two large tobacco warehouses. Pop. 2,061.

**EVAPORATION** (Lat. *evaporatio*, from *evaporare*, to emit vapor), the formation of vapor at the free surface of a liquid. In evaporation a portion of the liquid escapes in the gaseous form from the general mass, and, rising into the space, spreads through it according to the laws of diffusion of gases. Supposing the temperature of the space above the liquid to be uniform, the evaporation proceeds (provided there is a sufficient quantity of liquid) until the space is uniformly filled with vapor. A space thus filled with the maximum quantity of vapor corresponding to the temperature of it is said to be saturated. If the dimensions of the space be diminished, a portion of the vapor is forced to condense; if the temperature of the space falls, a portion of the vapor condenses also; while if the temperature of the space is increased, the dimensions remaining unchanged, the space ceases to be saturated, because the quantity of the vapor that corresponds to saturation is greater the higher the temperature. When there is not a sufficient quantity of liquid present to saturate the space completely, the whole of the liquid evaporates and the vapor diffuses uniformly through the space. The space is then said to be non-saturated. Consult the *United States Monthly Weather Review* for March 1914. See **BOILING POINT**; **VAPOR**.

**EVARTS, Jeremiah**, American editor and missionary secretary: b. Sunderland, Vt., 3 Feb. 1781; d. Charleston, S. C., 10 May 1831. He was graduated at Yale 1802, and settled in New Haven as a lawyer. His life was largely devoted to the interests of missions, he being editor of the *Missionary Herald* for a long term and corresponding secretary of the American Board of Commissions for Foreign Missions 1821-31.

**EVARTS, William Maxwell**, American lawyer and statesman: b. Boston, Mass., 6 Feb. 1818; d. New York, 28 Feb. 1901. He was graduated from Yale in 1837, studied law in the Harvard Law School and the office of Daniel Lord of New York, in 1841 was admitted to the bar, and in 1849-53 was assistant district attorney in New York. In 1851 he was successful in the conduct of the prosecution of the Cuban filibusters of the *Cleopatra* expedition. He was retained in 1857 and 1860 to argue the Lemmon slave case on behalf of the State of New York against Charles O'Connor, counsel for Virginia. An active and prominent Republican, he made the speech nominating Seward for the Presidency at the Republican National Convention in Chicago in 1860, though subsequently moving to make the nomination of Lincoln unanimous. In 1861 he and Horace Greeley (q.v.) were rival candidates before the State legislature for appointment to the senatorship vacated by Seward, newly made Secretary of State. As a compromise, Ira Harris was finally appointed. Evarts' legal knowledge was frequently employed in the service of the administration. On behalf of the government he conducted numerous important cases. Among such were that before the Supreme Court to establish the right

of the United States during the Civil War to deal with the captured ships as maritime prizes (1862), and that maintaining the unconstitutional character of the State laws taxing United States bonds or stock of the national banks without authorization of Congress (1865-66). He was principal counsel for Andrew Johnson (q.v.) in the President's trial for impeachment, and by his lofty judicial argument contributed much to a result which has since been regarded as most fortunate. He then went into Johnson's Cabinet as Attorney-General for the remaining year of the term. In 1872 he was chief counsel for the United States before the Geneva tribunal for settlement of the Alabama claims. As chief counsel for the Republican party before the electoral commission (q.v.) that settled the Hayes-Tilden Presidential dispute, Evarts based his argument on the constitutional idea that sovereign States must conduct their elections and govern themselves without Federal interference, pointing out that the electoral returns from Louisiana revealed the choice of Hayes electors. During Hayes' administration he was Secretary of State. He made, in 1880, a report upon the matter of American control of a trans-isthmian canal, whether at Nicaragua or Panama. His administration of the office was marked by skill in diplomatic questions, the improvement of the consular service and the publication of consular reports on the economic and commercial status of foreign lands. In 1881 he was a delegate to the international monetary conference at Paris, and in 1885 entered the United States Senate, his term expiring 3 March 1891. He was the senior partner in the law firm of Evarts, Choate and Beaman, and was frequently retained in important corporation cases. While in the Senate he made several noteworthy speeches and he also pronounced many distinguished occasional addresses, including the Centennial oration at Philadelphia in 1876.

**EVE**. See **ADAM**.

**EVE, Paul Fitzsimmons**, American physician: b. near Augusta, Ga., 1806; d. 1877. He was graduated at Franklin College in 1826 and at the medical college of the University of Pennsylvania in 1828. He then studied for two years in Europe, and in 1831 was surgeon during the Polish Revolution. In 1832-49 he was professor of surgery in Georgia Medical College, and in Louisville 1849, the University of Nashville 1850-68, and the University of Missouri in 1868-77. He was elected president of the American Medical Association in 1857. He published over 600 articles on medical subjects, including 'Remarkable Cases in Surgery' (1857).

**EVECTION** (Lat. *evectio*, "a turning upward"), the second inequality in the motion of the moon, due to the attraction of the moon by the sun. Owing to the evection the position of the moon may vary 1.20 degrees. It was discovered by Hipparchus nearly 200 years before the Christian era, and more completely determined by Ptolemy.

**EVELETH**, év'é-lèth, Minn., city of Saint Louis County, 70 miles northwest of Duluth, on the Duluth and Iron Range, and the Duluth, Missabe and Northern railroads. It has extensive dairying, lumber and iron-mining interests, a public library, etc. The commission



form of government was adopted in 1913. The waterworks are the property of the municipality. Pop. 7,036.

**EVELINA.** When 'Evelina' appeared, in 1778, its originality created a literary sensation. That Fanny Burney, a young woman of 25, in a period of mediocre and frequently indecorous imitations, should have produced a novel keen in observations, seemly in humor and spirited in execution, won admiration everywhere. To-day some of the newness has worn off and the artistry has been partially eclipsed by the genius of later writers. But 'Evelina' will always possess distinction as an early example of the novel of domestic manners as seen through clear and subtle feminine eyes; time cannot rob it of its intrinsic freshness, and, indeed, enriches it with a certain charming quaintness. The story is told in the form of letters, continuing in this respect the tradition of 'Pamela.' But most of the Richardsonian analytical psychology is omitted and the incidents are not as exceptional as those that were necessary to regale an earlier generation. With these modifications, the stress is laid upon the presentation of contemporary English life as it would impress an Evelina. The result is a degree of immaturity and externality as compared with the penetration of Jane Austen; however, the surface of society as it is reflected in the mind of the youthful letter-writer, is portrayed with undeniable vivacity and comic power. The comedy arises chiefly from the juxtaposition of contrasting ridiculous characters. They are simplified and exaggerated almost to the point of caricature, but they possess truth enough to make them human; and the comedy to which they give rise, though verging upon farce, is always amusing and wholesome. Among the varied types moves Evelina, finally successful in winning the recognition of her deceived father and the love of her noble admirer. She is in essence Miss Burney herself; and to the spontaneity and vividness of her reactions to the life about her the novel in the last analysis owes its vitality and charm. Consult Dobson, Austin 'Life of Fanny Burney'; Macaulay, Lord, 'Essays on Madame D'Arblay,' passim; 'The Early Diary of Francis Burney,' passim.

GEORGE B. DUTTON.

**EVELYN,** ěv'ě-lín, John, English writer: b. Wotton, Surrey, 31 Oct. 1620; d. there, 27 Feb. 1706. After completing his course at Oxford he began to study law at the Middle Temple. He made some efforts in favor of the royal cause in 1659, on which account he was much favored by Charles II after his restoration. In 1662 he published 'Sculptura, or the History and Art of Chalcography or Engraving on Copper.' On the foundation of the Royal Society he was nominated one of the first Fellows and at its meetings he read a discourse on forest-trees, which formed the basis of his most celebrated publication, 'Sylva, or a Discourse of Forest-trees' (1664). He continued in favor at court after the Revolution of 1688 and was made treasurer of Greenwich Hospital. He lived for many years at Sayes Court, Deptford, and subsequently succeeded to his brother's estate of Wotton, his life being that of a loyal, worthy, public-spirited country gentleman. Evelyn left a most interesting diary, picturing his life from 1641 to 1706, first published with

his correspondence in 1818. A new edition of the 'Diary' was issued in 1827; another, with life, by Wheatley, in 1879; and one by Austin Dobson in 1906.

**EVENING GROSBREAK,** a large finch (*Hesperiphona vespertina*) or western North America. It is olivaceous, with the crown, wings, tail and feet black; forehead and rump yellow; bill yellowish and a white patch on the wing. It inhabits the forests of northwestern Canada and the Rocky Mountain region, occasionally coming south into the upper Mississippi Valley in winter. This was the limit a few years ago, but since about 1905 the bird has extended its winter migration to eastern Canada, New England and New York, where it annually appears in increasing numbers and is reported to have bred in a few instances. Its nest is a rather rude structure placed in a tree; eggs, greenish, blotted with pale brown. This grosbeak feeds by preference on berries, especially those of the mountain ash, bittersweet and the like; also on buds, seeds, frozen apples, etc. It goes about in small flocks, uttering a variety of calls, and in spring sings in a loud, odd way, more striking than beautiful. Full accounts of the extraordinary winter-spread eastward of this interesting bird may be found in recent files of the ornithological magazines.

**EVENING PRIMROSE,** the common name of American plants belonging to the various genera of the family *Onagraceæ*, or evening primrose family. They are annual or biennial herbs, the yellow flowers opening either during the night or at evening. There are upwards of 40 species to which the name is applied, nearly all natives of North America, but some of them naturalized in Europe, particularly in England. Evening primroses, especially *Oenothera biennis* and related species, have attracted much interest because of experiments in plant breeding conducted with them.

**EVENING or NIGHT SCHOOLS,** schools in which instruction is given to pupils debarred, generally by reason of being wage-earners, from the advantages of the day schools. Evening schools arose at a time when compulsory education was not as widespread as at present and when more children were consequently growing up without instruction. Beginning with the idea of imparting the more rudimentary branches, such schools have extended their scope until in some cases they form departments of institutions devoted to the study of art, science or technology. In some of its wider aspects their work has become allied to the university extension movement.

**Central Europe.**—The evening schools in central Europe are largely the outgrowth of Sunday-schools which shortly after the middle of the 18th century began to add elementary secular instruction to religious teaching. The school age limit being less than at present, a review or continuation of school studies seemed of great importance. In Germany, beginning with lessons in arithmetic and the mother tongue, the range of instruction gradually widened. Some states made attendance obligatory at such Sunday-schools in certain cases. At present the term *Fortbildungsschulen* (literally "further developing schools") is applied in Germany and Switzerland to schools intended for pupils who have passed the elementary

school age and yet study the elementary branches. These *Fortbildungsschulen* are open only in winter and rarely require more than six hours of attendance in the week. Their object is to give boys a practical turn of mind by instruction fitted to bear upon their future callings. They do not furnish instruction in foreign or dead languages or the higher mathematics. In Switzerland, all the 25 cantons have systems of *Fortbildungsschulen* held on Sundays, holidays and in the evening. The evening schools of France, now numbering many thousands, appear not to date back farther than 1820. The tendency is toward technical training rather than liberal studies, but there are also evening classes or lectures open to those who desire a broader culture.

**Great Britain.**—In 1806 a benevolent association founded an evening school in Bristol, England, for young persons who were working for a living. In 1811 a school for adults was started in Bala, Wales, and others shortly followed in London and other towns. Such schools were originally supported by private benevolence or local funds, but the government, after a time, saw the wisdom of aiding them by grants. Since 1861 this aid has been greatly increased, but is not intended to supersede local effort. According to regulations issued by the Board of Education of Great Britain for the school year ending 31 July 1903, local funds were expected to meet 25 per cent of expenditure for the evening schools and such expenditure to be approved by the board. The schools must not be conducted for private profit. They are under supervision and examination by the board, are subject to its examinations and must report to it. Schools charging no fees are not generally recognized. Instruction must begin after 4 p. m. or on Saturday after 1 p. m. Students under 12 are not admitted nor those who attend day schools under government inspection (art students being excepted). The courses are as follows: (1) Literary and commercial; (2) art; (3) manual instruction; (4) mathematics and science; (5) home occupations and industries. The last course is largely for girls and includes "home nursing." The boys may take a course in ambulance training, in gardening, etc. Throughout London the evening schools give instruction in gymnastics and swimming and life-saving methods have been taught to some of the pupils. Evening classes have been held in London at various institutions such as University College, King's College, South Kensington Museum, etc. In the so-called provincial colleges evening classes constitute an important part of the work. Special schools give instruction in commercial branches, courses for women, art, technology and advanced science. The Education Department of Great Britain reported 1911-12 for the evening schools of England and Wales 7,749 schools inspected and 222,776 pupils enrolled.

In Scotland the Parliamentary grants for evening schools are administered by the Scotch Education Department, and are used as in England to supplement locally raised funds. The courses of study cover about the same ground. Gaelic is found on the curriculum, and agriculture, horticulture, navigation, military drill and swimming may all be learned.

Evening schools also exist in most of the countries of Europe and republics of Latin

America; and in Canada they are specially flourishing.

**United States.**—The first successful evening schools of the United States began near the middle of the 19th century, although an attempt without permanent results was made in New York in 1834. Boston and other large cities soon followed and evening schools gradually became a recognized part of the common school system. The aims of the pupils in the evening schools being generally very practical and their minds more mature, the methods and subjects of instruction are varied from those of the day schools. Branches relating to commercial and industrial occupations are naturally preferred. Free evening schools for instruction in drawing exist in some cities and drawing is included in the curriculum of some of the regular schools. Evening high schools have become common and in addition to these extensions of the public school system, various important institutions, such as Cooper Union, New York; the Maryland Institute, Baltimore, and the Drexel Institute, Philadelphia, offer evening courses of a highly varied and very valuable character, and of a range resembling that of the day classes. Free lectures also connect such schools with university extension methods.

The evening schools of the Young Men's Christian Association in the United States, in 1914, had 83,771 students, while the Young Women's Christian Association had 65,129. In the business and commercial schools reporting to the United States Bureau of Education in 1912, there were 134,818 students in evening classes. The evening schools connected with the city school system of the United States reported, in 1912, for cities over 10,000 inhabitants, a total of 204 cities, 9,476 teachers. Forty-one of these schools were in Massachusetts and the remainder were scattered over the other States. In 1911 Massachusetts added greatly to the efficiency of the State vocational education by extending its help in a very liberal and broad manner to the night schools. The greatest number of night schools are still to be found in the North Atlantic States and the smallest number in the South Central States and Territories.

**EVENING STAR** (also called **HESPERUS** and **VESPER**), the name given to any one of the planets seen above the horizon before midnight; especially applied to the planet Venus on account of its brightness. Mars, Jupiter and Saturn are the other chief evening stars.

**EVERDINGEN**, ev'er-ding-en, Aldart or Allart van, Dutch landscape painter: b. Alkmaar, 1621; d. Amsterdam, November 1675. His sea pieces, in which he represents the disturbed elements with great truth to nature, are particularly celebrated. In forest scenes, too, he was a master. He is known also as an able engraver by his plates to 'Reynard the Fox.'

**EVEREST**, SIR George, English military engineer: b. in Wales, 1790; d. 1866. He was educated at the Royal Military Academy at Woolwich, was commissioned second lieutenant in the Bengal artillery, and took part in a survey of Java and in engineering work on the Ganges. Later he was engaged on a survey of India and in 1830 was appointed surveyor-general of India, from which post he retired

in 1843. He was knighted in 1861 and was elected vice-president of the Royal Geographical Society in 1862. Mount Everest was named in his honor. He published 'An Account of the Measurement of Two Sections of the Meridional Arc of India' (1847).

**EVEREST, Mount**, the highest known mountain in the world, is a peak of the Himalays, in Nepal near the Tibet frontier. It is 29,002 feet high, or about five and one-half miles. It was named in honor of Sir George Everest, an Englishman who for a time was surveyor-general of India. This mountain has been confused with Gaurisankar, whose twin peaks lie 36 miles west of Everest.

**EVERETT, Alexander Hill**, American diplomatist: b. Boston, Mass., 19 March 1792; d. Canton, China, 29 May 1847. He was graduated from Harvard in 1806, was admitted to the bar, and, after serving as chargé-d'affaires at The Hague, was Minister to Spain in 1825-29. He then became editor of the *North American Review*, and was elected to the State legislature of Massachusetts. In 1840 he was appointed special agent to Cuba, and from 1845 until his death he was a commissioner to China. To the *North American Review* he contributed a large number of essays. While resident in Cuba he was appointed to the presidency of Jefferson College, but ill health compelled his return north. He was at first a member of the National Republican or Whig party, but later supported Jackson. His work on 'Europe, or a General Survey of the Political Situation of the Principal Powers, with Conjectures on their Future Prospects' (1822) was highly esteemed in its time, and was published in French, Spanish and German. In 1827 appeared his somewhat similar book on 'America.' Among his other volumes are 'Critical and Miscellaneous Essays' (1st series, 1845; 2d series, 1847) and 'Poems' (1845). He wrote also biographies of Patrick Henry and Joseph Warren for Sparks' series of 'American Biography.' Other works were 'New Ideas on Population' (1822); and orations on 'The French Revolution'; 'The Battle of New Orleans,' and 'The Battle of Bunker Hill.'

**EVERETT, Charles Carroll**, American Unitarian clergyman: b. Brunswick, Me., 19 June 1829; d. Cambridge, Mass., 17 Oct. 1900. He was graduated at Bowdoin College, and afterward studied at the University of Berlin. He returned to Bowdoin College, where he was tutor for two years, librarian for five and professor of modern languages 1855-57. He was ordained pastor of the Independent Unitarian Congregational Church in Bangor, Me., 1859, but resigned in 1869 to become professor of theology in Harvard Divinity School, and was dean of the school from 1879 till his death. Among his published works are 'The Science of Thought' (1869); 'Religions Before Christianity' (1883); 'Fichte's Science of Knowledge' (1884); 'The Gospel of Paul' (1893); 'Psychological Elements of Religious Faith' (1902); 'Immortality and Other Essays' (1902); 'Theism and Christian Faith' (1909).

**EVERETT, David**, American writer: b. Princeton, Mass., 29 March 1770; d. Marietta, Ohio, 21 Dec. 1813. He studied law in Boston, and while there wrote for *Russell's Gazette*

and a literary paper called the *Nightingale*. He edited the *Boston Patriot* (1809), and the *Pilot* (1812). His works include 'The Rights and Duties of Nations,' an essay; 'Darenzel,' a tragedy (1800); 'Common Sense in Déshabille, or the Farmer's Monitor.' He wrote the well-known lines beginning—

You'd scarce expect one of my age  
To speak in public on the stage.

**EVERETT, Edward**, American statesman and orator, brother of A. H. Everett (q.v.): b. Dorchester, Mass., 11 April 1794; d. Boston, 15 Jan. 1865. He was graduated from Harvard in 1811, pursued studies in divinity, became in 1813 pastor of the Unitarian Church, Brattle street, Boston, and in 1814 published his 'Defence of Christianity' in reply to the 'Grounds of Christianity Examined' of George G. English. In 1814 he was also chosen to occupy the newly established chair of Greek literature. To qualify himself for the post he went to Europe in 1815 for a course of travel and study. He was for two years at the University of Göttingen, and later sojourned in France, England, Italy and Greece. In 1819 he returned to enter on the duties of his professorship. He became also in 1820 the editor of the *North American Review*, and in 1820-24 contributed to it about 50 papers. He was elected to Congress in 1824, and by successive re-elections held his seat until 1834. Throughout this period he was a member of the Committee on Foreign Relations and in the 20th Congress its chairman. He drew either the majority or the minority report of many select committees. In politics he was a National Republican (Whig). He declined a renomination to Congress in 1834. In 1835 he was elected governor of Massachusetts, subsequently was three times re-elected, holding the office for four years, and in 1839 was defeated by a majority of one vote. While in Europe in 1840 he was appointed Minister Plenipotentiary to England. At a time when there were many points of controversy between England and the United States he was successful in the adjustment of numerous important questions. He declined in 1843 an appointment as commissioner to China, and in 1845 was recalled. In 1846-49 he was president of Harvard, and in 1852 he became Secretary of State in Fillmore's Cabinet for the last four months of the latter's administration. During this brief term of office he settled several difficult matters. In a diplomatic note he declined the joint proposition of Great Britain and France that the United States should enter a tripartite convention which should guarantee to Spain exclusive possession of Cuba in perpetuity. Before he left the Department of State he was elected to the Senate. There he vigorously opposed the Kansas-Nebraska bill for the repeal of the Missouri Compromise. He resigned his seat in May 1854. From 1856 to 1859 he pronounced his well-known lecture on Washington in all on 122 occasions, realizing thereby nearly \$60,000, which he turned into the treasury of the Mount Vernon Association for the purchase of Mount Vernon by private subscription. He prepared a collective edition of the orations and speeches of Daniel Webster, with an introductory biographical notice; wrote a life of General Stark for Sparks' 'American Biography'; and prepared for the 'Encyclopædia

Britannica,' at the instance of Macaulay, a life of Washington, afterwards separately published (1860). In 1860 he reluctantly became a candidate for the Vice-Presidency on the Constitutional-Union, or, as it was sometimes known, the Bell-Everett ticket—John Bell (q.v.) being the Presidential candidate. The ticket received 39 electoral votes,—those of Kentucky, Tennessee and Virginia. During the Civil War he was a staunch Unionist, but disposed also toward a policy of reconciliation. He delivered the address at the dedication of the national cemetery at Gettysburg, Pa., 19 Nov. 1863, and in the Presidential election of 1864 as an elector-at-large he cast his ballot for Lincoln and Johnson. His last public appearance was at Faneuil Hall, 9 Jan. 1865, where he spoke on behalf of the sufferers at Savannah.

Everett was noteworthy in his versatility,—a preacher and theologian, a Greek scholar, an editor and author, orator, diplomat and statesman. He attracted much attention by his pulpit eloquence. As a Grecian he was thoroughly equipped and gave in his time a considerable stimulus in America to the study of Greek letters, antiquities and history. His literary productions were carefully wrought and marked by his scholarship; but, through interruptions by other activities, they were limited, so far as published, chiefly to his *North American* articles and the above-mentioned 'Defence of Christianity.' He did not complete a treatise on public law—a subject he was eminently fitted to expound,—on which he was for some time at work. His utterances in Congress showed him rather the orator than the debater, and while a member of the lower house he stood apart from much of party contention as it there appeared. He took, however, a prominent part in discussion, and, as indicated above, was a most valuable committee member. While he was a foreign minister the general negotiations regarding the northeastern boundary and Oregon difficulties were transferred from him through the appointment by Great Britain of Ashburton as special ambassador, yet many of the points in dispute were left to Everett's skilful adjustment. As representative, secretary and senator he held to the possibility of saving the Union by compromise on the slavery question, but, the war once begun, he was among the ablest supporters and advisers of the Federal government. It is as an orator that Everett is best known. His addresses were generally written with elaborate care, and were of the Ciceronian type in the knowledge and culture displayed as well as in their finished rhetoric. More fully than any other American orator he combined the resources of learning with the arts of the speaker. He lacked Webster's fire and Phillips' magic, but his manner was always impressive and well-poised. Even in his own time, however, his oratory did not escape criticism for lack of directness and artificiality, and this charge has frequently been made against it. He may be called the pioneer in the American "lyceum," which long had such a reputation. His 'Orations and Speeches on Various Occasions' were collected in four volumes in 1853-68. Consult also Dana, 'An Address upon the Life and Services of Edward Everett' (Cambridge 1865); 'A Memoir of Edward Everett' (Boston 1865); and Whipple's remarks in 'Char-

acter and Characteristic Men,' pp. 243-252 (1866).

**EVERETT, James**, English clergyman: b. Alnwick, Northumberland, 16 May 1784; d. Cumberland, 10 May 1872. In 1807 he began to preach as a Wesleyan Methodist minister. In 1821 he retired until 1834 and was in the book business at Sheffield, later at Manchester. In 1842 his health compelled a second retirement. From 1846 to 1848 he published the notorious 'Fly Sheets' intended to expose the inefficiency in the affairs of the Wesleyan Methodist Connection. This led to his expulsion from the Wesleyan ministry along with his friends William Griffith and S. Dunn. They formed the Wesleyan Reform Union which later united with other liberal Methodists and formed the United Methodist Free Churches. He was president of the Conference of this body. He was a voluminous author and a poet of no mean ability. His most noted book was 'The Village Blacksmith' (1831), which passed through many editions. He was also the biographer of his friend Adam Clark, the great commentator. He assisted John Holland in the preparation of the life of the poet James Montgomery (7 vols., 1854).

**EVERETT, Joseph David**, English physicist: b. Rushmore, near Ipswich, 11 Sept. 1831; d. 9 Aug. 1904. He was educated at Glasgow University; was professor of mathematics, King's College, Nova Scotia, 1859-64; assistant in mathematics, Glasgow University, 1864-67; and professor of natural philosophy in Queen's College, Belfast, 1867-97. He took a leading part in the selection and naming of dynamical and electrical units, and drafted a report (1873), the adoption of which originated the C.G.S. system now generally employed. His 'Universal Proportion Table,' was the first application of the parallel column arrangement for obtaining a slide-rule with very open scale. His English version of M. Privat-Deschanel's 'Physics' (1870) was so largely rewritten as to be almost an original work. Other of his publications are 'Centimètre-Gramme-Second System of Units' (1875); 'Elementary Text-Book of Physics' (1877); 'Shorthand for General Use' (1877); 'Vibratory Motion and Sound' (1882); 'Batteries of Natural Philosophy' (1887), etc.

**EVERETT, William**, American educator, youngest son of Edward Everett (q.v.): b. Watertown, Mass., 10 Oct. 1839; d. Quincy, Mass., 15 Feb. 1910. From 1870 to 1877 he was assistant professor of Latin at Harvard. He was master of Adams Academy at Quincy, Mass., 1877-93 and in 1897, and was member of Congress 1893-95. He was the author of 'On the Cam' (1865); 'Changing Base' (1868), 'Double Play' (1870), two books for boys; a poem, 'Hesione, or Europe Unchained' (1869); 'School Sermons' (1881); 'Thine, Not Mine'; and many pamphlets on political, literary and religious subjects.

**EVERETT**, Mass., city in Middlesex County, three miles north of Boston, on the Boston and Maine Railway and with connection by electric surface lines with Lynn, Salem, Chelsea, Boston and adjacent towns. According to the report of the 13th United States census there were in Everett 62 establishments, with a capital of \$22,905,000, employing 2,680

wage-earners at wages amounting to \$1,979,000 and having a product valued at \$8,747,000. The most important manufactories are a chemical plant, structural iron foundries, steel works and gas and coke works, radiators, shoes, coal-tar products, leather, beds, concrete blocks, tools, wagons, boxes, trunks, etc. The United States census of manufactures for 1914 showed within the city limits 85 industrial establishments of factory grade, employing 3,788 persons; 3,226 being wage-earners receiving annually a total of \$2,047,000 in wages. The capital invested aggregated \$26,409,000 and the year's output was valued at \$13,219,000; of this, \$6,708,000 was the value added by manufacture. There are two public libraries, the Shute Memorial and the Parlin Memorial, and the Whidden Memorial Hospital is also located here. Everett was settled in 1643 and until 1870 it was a part of Malden. It received its city charter in 1892. Its chief development was in the decade 1890-1900. The government is administered by a mayor, chosen annually, and a municipal council in which members of the lower chamber are elected by wards for one year, those of the upper chamber at large for two years. The more important of the subordinate officials are nominated by the mayor and confirmed by the council; the others are chosen by the council. Pop. 37,381.

**EVERETT**, Wash., city, county-seat of Snohomish County, on Puget Sound, on the Northern Pacific, the Great Northern, the Chicago, Milwaukee and Saint Paul railroads, about 55 miles east by north of Tacoma and 30 miles north of Seattle. It has an excellent harbor with water communication with the Pacific and agricultural lands, forests and valuable mines nearby. Such a combination of natural resources is not common. Everett is the entrepôt of the towns and camps in a rich mining belt. Within a district 36 miles long and 20 miles wide, the Monte Cristo, Great Lake, Silver Creek, Troublesome, Sultan, Stillaguamish and North Fork district send ores to the great smelter in Everett and in various ways contribute naturally to the substantial growth of the city. The city trades extensively in lumber, having some of the largest plants in the Northwest. Red-cedar shingles are the most important products. The smelter and refinery plant obtains mineral from all over the Northwest. The city contains railroad shops, flour- and lumber-mills, large shipyards, sash and door factories, saw and shingle mills and one of the two plants in the United States for saving arsenic from smelter fumes. There are several well-built brick buildings, churches, a theatre, graded streets, electric light and motor power, sewers, school houses, newspapers, a Carnegie library, two hospitals and the United States customs and assayer's offices, etc. Its school system is excellent. Everett was settled in 1891, incorporated in 1893. Its growth has been rapid because of its favorable situation as a commercial port, its transportation facilities and its nearness to extensive forests. It has adopted the commission form of government. Pop. 32,048.

**EVERETT-GREEN, Evelyn**, English writer: b. London, 17 Nov. 1856. She is the daughter of Mary Wood Everett-Green (q.v.). She was educated at Bedford College, London;

studied music at the London Academy; and for two years was a nurse in a London hospital. Since 1883 she has devoted herself entirely to writing. Among her many published works the best known are 'The Last of the Dacres' (1886); 'St. Wynfriths' (1893); 'Dare Lorrimer's Heritage' (1892); 'Dominique's Vengeance'; 'Shut In' (1894); 'Over the Sea Wall' (1894); 'Arnold Inglehurst the Preacher' (1895); 'Squib: His Friends' (1896); 'French and English' (1898); 'Odeyne's Marriage' (1899); 'The Heir of Haskett Hall' (1899); 'Monica' (1900); 'After Worcester' (1901); 'For the Faith' (1901); 'Olivia's Experiment' (1901); 'In Fair Granada' (1901); 'Fallen Fortunes' (1902); 'Alwyn Ravendale' (1902); 'Hero of the Highlands' (1903) 'Dufferin's Keep' (1905); 'The Magic Island' (1906); 'Married in Haste' (1907); 'The House of Silence' (1910); 'The Evolution of Sara' (1911); 'Blackladies' (1914); 'The Double House' (1915); 'Confirmed Bachelor' (1915).

**EVERETT-GREEN, Mary Anne** (Wood), English author: b. Sheffield, 1818; d. London, 1 Nov. 1895. She moved to London in 1841 and for nearly 40 years was employed in the record office as one of the editors of the 'Rolls Series of State Paper Calendars.' The works edited by her include 'Letters of Royal and Illustrious Ladies of Great Britain' (1846); 'Diary of John Rous' (1856); 'Letters of Henrietta Maria' (1857); 'Life of William Whittingham' (1870). Her only original work was the 'Lives of the Princesses of England from the Norman Conquest, (1850-55).

**EVERGLADES.** The name given to a vast tract of land and water in the southernmost part of Florida, a region, though under the very eyes of the early pioneers and bordered by our own advanced lines of commerce and travel, remained practically undiscovered until the first decade of the 20th century. It is not a marsh, a swamp nor a stagnant pool; neither land nor water. No white man had penetrated it for any great distance, either by boat or on foot, owing to the variance in the depths of the water and the dense tangle of saw-grass, scrub-willow and custard-apple which abounded there. The State of Florida is one immense mountain top of limestone formation, covered with a network of pot-holes, varying in size from a few feet to thousands of acres; it has countless lakes of fresh water, fed by springs and subterranean streams, and among these is Lake Okeechobee, named by the Indians Lake Mayaimi; at the southern end of the lake began the district known as the Everglades. This vast marsh lay in Dade, Lee, Monroe and Palm Beach counties, extending southward from the lake about 110 miles and having a breadth of about 45 miles. Over the rocky bottom of this region lay a layer of muck, formed of alluvial deposit and decayed vegetation, varying in thickness from a few inches to several feet, and in this muck the saw-grass found its origin, took root and sometimes grows to a height of 10 feet. This saw-grass is one of the most peculiar and interesting features of the Everglades. Shooting up rapidly, pale green in color, as it goes through the water, fading in the sunlight to a dull golden tint, its blades are tough as bamboo, its edges sharp and jagged as a saw. Toward the western end of the lake it

is interwoven with wild myrtle and formed an almost impassable barrier, running through the entire length of the lake, although there are some passages through it, known familiarly to the Seminole, but which are almost impossible to locate by the explorer.

Scattered along the eastern and western edges of the marsh are numerous islands, some very small, others hundreds of acres in extent, covered with luxuriant growths of live oaks and bays, interspersed with wild cucumber, lemon and orange trees. The papaya, the custard-apple and prickly-ash are of frequent occurrence, and here and there may be seen the cabbage palmetto, the pine and the rubber-tree.

The first white man to enter this mysterious, silent country was a Spaniard, one Escalente de Fontenada, who, after being shipwrecked in the Strait of Florida, was made captive and slave by the great cacique, Calos, but he has left us only a few meagre details of his experiences during his 17 years of captivity. Frequent expeditions of exploration were sent out by the United States government from 1847 to 1900 to penetrate this wilderness if possible, but all failed, each bringing the explorers, after days of hardships and privations, to the conclusion that the Everglades, though fascinating in its wildness, was a region to be avoided; a forest of trees, rank undergrowth and saw-grass, impenetrable and practically valueless; and the lake a mixture of currents which seemed to begin without reason, led nowhere in particular and generally ended in a comparatively still pool, with a labyrinth of passages from which there seemed no direct egress.

Animal life in the Everglades is fairly abundant, deer being found on both eastern and western shores, otter are plentiful, alligators and crocodile quite numerous, while the snake is there in large numbers. The Glades were once the breeding place for the egret, the ibis and the heron, and, while many of them are yet to be found, the plume hunter has made such inroads that all are nearly extinct. Small flies and gnats are found where the foliage is thick, as in all regions.

Probably the most interesting of the denizens of the Everglades are the Seminole Indians, divided into two clans or families, the Muskokis and the Mikasukes, who for hundreds of years have inhabited this section of Florida, defying all attempts to dispossess them, and in 1835, during the Seminole War, killing a large number of troops, under Major Dade, sent against them. The shores of the streams by which the Glades are entered are covered with the cocoa-plum tree, which also grows about the edge of the Glades, producing a blue fruit on the eastern and a white fruit on the western edge. Wherever the land is sufficiently dry, the coontie-plant, really the Florida arrow-root, grows, and from these the Indian gets his sustenance, extracting flour and starch from the roots.

The physical features of the Everglades are beyond description, beauty and charm blending in a strange, sweet sense of mystery. In dry weather, when the water is low, it is possible to drive into the Glades, but the most beautiful and ideal approach is by water, all the rivers of the Glades finding their way to the sea, some by the rocky channels worn by their own age-long floods, and some through miles of wandering

curves, their shores lined with forests of mangrove trees.

Looking into these forests, only the dark waters are to be seen. Ascending, the fresh water of the Glades overcomes the brackish tidal water, and the cocoa-plum takes the place of the mangrove. Still farther up the river, the cocoa-plum gives way to the cypress, and pond lilies abound, the whole panorama of shifting green,—the lemon-like foliage of the cocoa-plum, the dark olive of the mangrove, and the lighter green of the cypress, enlivened by the sunlight,—making a scene of unique beauty.

In the perspective, when the water is low, the Glades, with its numerous islands and with the tall golden grass, gleaming in the sunshine, waving over a field of silver, ending with a sky-line of blue, has a charm for the eye, unequaled, perhaps, by any other spot in the world, and gives to the sightseer or explorer that subtle impulse and uncontrollable desire to adventure into this never-ending plain of grass and water, never reaching the goal but always seeking for something that lies just beyond the horizon.

The climate of the Everglades is faultless, showing no extremes of heat or cold, nor is it subject to sudden change. There are two seasons in the year, the rainy and dry, the latter including June and September, although light showers may be expected at any season, and in the autumn the humidity is very high. Malaria is seldom heard of, the pure air giving the best assurance of health, and it is small wonder that the ancient explorers spent years here trying to find the "Fountain of Youth."

The title to the Everglades is vested in the trustees of the Internal Improvement Fund of Florida, under patents from the Department of the Interior of the United States, by virtue of an act of Congress of 1850, and they promoted efforts to drain the Glades and open it to actual settlers, the cost of reclamation being small compared to the great agricultural value.

A private company set about building a drainage canal from Lake Okeechobee to the New River in 1881, but owing to faulty planning the project failed. A definite plan was finally outlined by the State in 1906 and work was promptly begun. This plan provided for a series of main canals to be dredged from the coast to the lake, with the purpose in view of lowering the level of the lake sufficiently to stop the overflow of its waters into the Everglades, and to lower the water level there by means of these same canals. At the present time five canals of a total length of over 200 miles and of an average depth of 5 feet with a 60-foot width have been completed and have served to reclaim about 1,000,000 acres, although certain acres have not received sufficient protection against overflow during heavy raining season. The success of this work proved that a great part of the remainder—2,700,000 acres—could in time be reclaimed by the natural incline of the surface, from the flood source to the rivers entering the sea. A contract was let to a dredging company of Baltimore to excavate nine canals aggregating 425 miles. All of these waterways are now under construction, with widths ranging from 50 to 60 feet for the larger, and an average of 25 feet on three smaller ones. The depth of the main canals ranges from five to seven feet, while some average four feet.

The excavation is accomplished by huge dredges and ditching machines of the clamshell, dipper and suction types according to the nature of the formation in which they are employed. Floating dynamite plants are employed for rock excavation, and are equipped with steam-driven shovel buckets for removing the rock blown out from the bottom of the cut. The work is proceeding at such a pace that soon about one-third of the entire area will be ready for the farmer and the settler. The Everglades, where drained, are being occupied by settlers from all parts of the country. Every kind of fruit and vegetable raised in the temperate zone can be cultivated at a profit in Florida. Oranges, bananas, pineapples and other varieties may be added to the list. The farms under cultivation in the reclaimed portion prove the truth of this. The new land is being sold in large tracts by the State authorities to be divided into truck and other farms, but the possibility of producing sugar is perhaps the most important. The total cost of the reclamation project under the plan of 1906 has been about \$4,500,000 or \$1.125 per acre. For acts, reports and official papers relating to the reclamation scheme, and giving much valuable information concerning the region, consult 'The Everglades,' Senate Document No. 89, 62d Congress, 1st Session (Washington 1911); 'Florida Everglades,' Report of the Everglades Engineering Commission, Senate Document No. 379, 63d Congress, 2d Session (ib. 1914); Rhodes and Dumont, 'Guide to Florida' (New York 1912) also Willey, D. A., "Draining the Everglades," in *Scientific American*, Vol. CIV, No. 2 (21 Jan. 1911); id., "Reclaiming the Everglades," in *Scientific American*, Vol. CXV, No. 12 (16 Sept. 1916); and Dimock, "The Passing of a Wilderness" in *Scribner's Magazine*, Vol. XLI (March 1907).

**EVERGREEN, Ala.**, town, county-seat of Conecuh County, on the Louisville and Nashville Railroad, about 100 miles northeast of Mobile. An agricultural school and experiment station and the State Baptist Orphan Asylum are located here. Its mineral springs and agreeable climate make it a winter resort. The town is interested chiefly in agriculture, lumbering and market gardening, and contains a veneer mill, box factory and saw mill. The waterworks and electric-light plant are owned by the municipality. Pop. 1,582.

**EVERGREEN ISLE**, a poetical name given to Ireland.

**EVERGREENS.** Those plants which imperceptibly shed their leaves and acquire new foliage, without noticeable change in their aspect, and those which, like certain biennials and alpins, maintain their leaves throughout the winter season so that they may make a quick start in the spring, are called evergreens. In the northern countries cultivated evergreens are roughly divided into two groups popularly called conifers and "broad-leaved" evergreens, the latter including laurels, rhododendrons, hollies, box, etc. The tropical flora is chiefly evergreen, and some trees, like the *Magnolia glauca*, that shed their foliage in the north, retain it in the south.

This evergreen character, especially where the plants are subjected to extremes of drought and wetness, or of heat and cold, has given

rise to many devices for regulating transpiration or the deleterious effects of too much moisture, such as the rolling of leaves, waxy deposits on the leaves, and various curious arrangements of pits, hairs and cells. Whenever the foliage is persistent for several years, as is the case of the holly and of many tropical trees and epiphytes, it is often thick and leathery, being provided with a thickened cuticle, especially where the leaf undergoes drought periodically. Other evergreens like cacti and rock-plants become fleshy or succulent, when living in arid conditions, storing water in their tissues and sometimes retaining it there with mucilaginous juices and salts. Furthermore they are apt to assume a more or less cylindrical shape in both leaf and stem, the foliage often being reduced to mere needles and scales, or being absent entirely. This rodlike, nearly leafless, condition is particularly noticeable in the so-called whip-plants of arid regions, which are reduced to switch branches with scales for leaves, thus greatly reducing the evaporating surface during the heated term. They often occur on the Mediterranean shores where another type of device for controlling exhalation is conspicuous; for there the evergreens are really gray, like the lavender, hoary with their envelopes of hair, just as some alpine plants, notably the edelweiss, are smothered in felted hairs. In the shadowless forests of Australia many trees reduce their evaporating surfaces by presenting only the edges of their leaves to the midday sun.

Coniferous evergreens furnish some of our most valuable forest products in the way of timber, naval stores and tanning materials, and also various food products as nuts and bark, chiefly of value to the aborigine. One or two, as the West Indian yacca and the yew, furnish cabinet woods, but the latter seems to have been used wherever it grows, chiefly for bows. Most of them also are useful for windbreaks, hedges or for ornamental planting, where shelter, concealment or winter-color is desired; various species being adapted for differing soils and climates. Some of them, as the arbor-vitae and yew, stand shearing well, and can be pruned into sundry geometrical forms; holly and box share this distinction, and the custom was formerly carried into grotesque excess in topiary gardening.

Laurel, rhododendrons and other "broad-leaved" evergreens are often valuable in shrubberies not only on account of their winter verdure but because they also have handsome blossoms or fruit; they moreover afford shelter for birds.

Their long life and perpetual verdure have caused many of the evergreen tribe, particularly the fir and mistletoe, to be included among sacred plants; and they have become adopted as symbols of immortality, of resurrection and of perennial remembrance, at funeral services and in graveyards. Several kinds, as the yew, served as "palms" on Palm Sunday. On the other hand, yews and cypresses, especially the latter, serve as emblems of eternal death and are frequently referred to in this connection in classical literature "with every baleful green denoting death."

Evergreens are favorite plants for decorating during the Christmas holidays; in England

a certain order was observed in their disposal, as we find in Herrick's 'Ceremonies for Candelmas Eve':

Down with the rosemary and bays,  
Down with the mistletoe;  
Instead of holly, now upraise,  
The greener box, for show.

Then youthful box which now hath grace  
Your houses to renew,  
Grown old, surrender must his place  
Unto the crisped yew.

Presumably these holiday garlands and decorations of evergreens—rosemary, ivy, laurel, box, holly and mistletoe—were survivals, with the Christmas tree, of pagan ceremonies and tree-worship, more or less incorporated in the rites of the early Christian churches; the mistletoe, however, was so intimately connected with Druidical rites that it was excluded from the Church decorations. There is a large trade in these Christmas greens, both of the foreign and native kinds, the latter including southern smilax, long-eared pine, ground-pine and hemlock.

HELEN INGERSOLL.

**EVERHART, Benjamin Matlack**, American botanist: b. West Chester, Pa., 24 April 1818; d. 22 Sept. 1904. After a successful business career in his native town and Charleston, S. C., he retired in 1867 and devoted himself to botanical study, becoming a recognized authority on cryptogamic botany. With J. B. Ellis, of New Jersey, he published in 50 parts a notable work entitled 'The Century of North American Fungi,' describing 5,000 species, many of which were discovered by Everhart. With W. A. Kellerman, professor of botany in Ohio State University, he founded and edited 'The Journal of Mycology,' to which he contributed numerous articles on his specialty. Several new fungi discovered by him have been named after him by his fellow-scientists.

**EVERLASTING FLOWERS**, a name applied to certain plants belonging to the family *Asteraceae*, from the fact that when dried they suffer little change in their appearance. By the French they are called *immortelles*, and this name has been introduced into our own language as applied to wreaths made of such flowers to be placed beside recent graves as emblems of immortality. The plants to which this name is most commonly applied belong to the genus *Helichrysum*, and are natives of southern Africa and Australia; but it is also given in America to members of allied genera, such as *Antennaria*, *Gnaphalium*, *Anaphalis*, etc. The native women of Australia are fond of decorating their hair with the flowers of *Helichrysum elatum* and *Helichrysum bracteatum*. See AMARANTHUS.

**EVERLASTING GOSPEL**, The. See JOACHIM DE FLORIS.

**EVERLASTING MERCY**, The. 'The Everlasting Mercy' (1911), by John Masefield, is a poem of some 1,800 lines, telling the old story of a man's degradation and redemption. Life, while ruthlessly bringing every man's sowing to the harvest, is always merciful enough to keep open the way that leadeth out of evil. Masefield prefers the familiar simile of the Christ knocking at the door of one's inner self. It is the story of one Saul Kane

(the name is suggestive of two biblical characters and incidents), who at the age of 20 "was tokened to the devil." The crisis in his depravity is hastened by the fight with Billy Myers, precipitated by a poaching adventure and succeeded by a drunken debauch at "the Lion." After "three long hours of gin and smokes" with every nerve on edge and mind a-swirl in a tumult of accusing thoughts his reason reeled and a madness that was not wholly from "Hot Hollands punch on top of stout" seized him. Throwing boots and torn clothes and glasses through the window he leaps out and rushes through the street,

A naked madman waving grand  
A blazing lamp in either hand

He wakens the sleeping town with a furious ringing of the fire bell. When the firemen rush toward him he flees and they, because of his nakedness and his wild yelling,

I'm fire of hell come up this minute  
To burn this town and all that's in it.

think him an escaped lunatic. Having shaken his pursuers he returns to "the Lion" and sleeps. On waking a second spell of madness rushes him to the street. On seeing "old puffing parson," with exaggerated rudeness he bars his path and pours out a scathing criticism of the established religious and social order, not sparing even the parson:

O, what are you, and what you preach,  
And what you do, and what you teach  
Is not God's Word, nor honest schism,  
But Devil's cant and pauperism.

Masefield is at his best when criticizing the social order, but the sanity of his spirit is well disclosed in the parson's pointed and effective reply. Saul Kane drunk and exaggeratedly boastful in his degradation is not bad all through. Before the fight began he looked at

The five and forty human faces  
Inflamed by drink and going to races,  
Faces of men who'd never been  
Merry or true or live or clean.

It is a man's sympathy rather than a drunkard's that prompts Kane to comfort little Jimmy Jaggard who has lost his mother in the market place. Jimmy's mother hurries to the scene as soon as she is warned that "Saul Kane, the drunken braggard," is talking to her Jimmy, and in her crude, unlettered and forceful way she pictures Kane to himself and to the assembled crowd with pitiless accuracy, so that he confesses that

This old mother made me see  
What harm I done by being me.

And

Summat she was, or looked, or said,  
Went home and made me hang my head.  
I slunk away into the night  
Knowing deep down that she was right.

Put thus to shame before himself and the people he drowns the mortification he felt in deeper drunkenness which spurs him to a more brazen assertion of depravity as exhibited in the insult offered to Miss Bourne, who regularly visited the saloons "To bring the drunkards' souls to grace," an act which shocked even his companions in drunkenness. This insult recoiled upon him with such force from the clean soul and simple word of Miss Bourne that it caused something to snap inside his brain. The remaining part of the poem describes his wandering "out into darkness, out to night," merging



into the dawn of a new day, the birth of a new self, and the finding of the "everlasting mercy, Christ." The whole poem grips and holds the reader with the intensity of its realism and speed of action. One forgets that it is verse and feels the touch of flesh and blood.

**EVERLASTING PEA**, a popular name for plants of the genus *Lathyrus*, of the pea family. In the United States it is applied to the beach pea (*L. maritimus*), because it often blossoms until late in the fall. In Europe the everlasting pea is *L. latifolius*, a cultivated plant like the sweet pea, sometimes cultivated for ornament in North America.

**EVERMANN**, Barton Warren, American ichthyologist: b. Monroe County, Iowa, 1853. In 1886 he was graduated at Indiana University, after which he spent 10 years as teacher and superintendent of schools in Indiana and California. In 1888 he began his connection with the United States Bureau of Fisheries, was made ichthyologist in 1891 and from 1903 to 1911 was chief of the division of scientific inquiry. Thereafter, until 1914, he had charge of the Alaska Fisheries Service. In 1892 he was also United States fur-seal commissioner and in 1908 was made chairman of the fur-seal board. At various times he lectured at the universities of Cornell, Stanford and Yale. He is the author of several bulletins of the United States Fish Commission and has contributed to the proceedings of several learned societies.

**EVERSLEY**, 1ST BARON (George John Shaw-Lefevre), English statesman: b. 12 June 1832. He received his education at Eton and at Cambridge University. In 1855 on the completion of his studies in law he was called to the bar. He unsuccessfully contested Winchester at the election of 1859, but was successful in 1863, when he was elected member for Reading, which seat he held until 1885, when he was elected from Bradford. In 1856 he became civil lord of the Admiralty and in 1858 was appointed commissioner to negotiate a convention on fisheries with the French government. He carried the vote in the Commons, in 1868 for the arbitration of the claims arising from the *Alabama*. From 1869 to 1871 he was secretary of the Board of Trade and in the latter year was made undersecretary at the Home Office. In 1871-74 he was secretary to the Admiralty; in 1881-83 first commissioner of works and in 1883-84 postmaster general. In 1892-93 he was a member of the Gladstone ministry and in 1894-95 was president of the Local Government Board. While in the Commons he sponsored many important legislative bills, especially dealing with modern social legislation. He was created first baron in 1906. He published 'English and Irish Land Questions'; 'Incidents of Coercion'; 'Peel and O'Connell'; 'Agrarian Tenures'; 'English Commons and Forests'; 'Gladstone and Ireland' (1912); 'The Partitions of Poland' (1915).

**EVERY MAN IN HIS HUMOUR**, the first comedy of Ben Jonson, which has come down to us. It was produced at the Globe Theatre in 1598, with Shakespeare in the cast

and was printed in 1601. David Garrick later revised it and achieved a great success in the principal rôle.

**EVERY MAN OUT OF HIS HUMOUR**, a satirical comedy by Ben Jonson, first produced in 1599.

**EVESHAM**, *ëvz'ham* or *ëvz'am*, England, municipal borough and market town in the county of Worcester, on the Avon, 15 miles southeast of Worcester, beautifully situated in the vale of Evesham. It is an ancient place and was the scene of a battle fought in 1265, which replaced Henry III on the throne. It had a celebrated abbey, of which a fine tower and some other structures still remain. Fruit growing and market gardening are the chief industries. Pop. 8,340.

**EVICTION**. See **EJECTMENT AND EVICTION**.

**EVIDENCE**. "The word evidence considered in relation to law includes all the legal means which tend to prove or disprove any matter of fact the truth of which is submitted to judicial investigation." (Taylor). Evidence may be either oral or documentary. Oral evidence is the statements made by witnesses during the trial; and documentary evidence consists of the production of papers, on which is writing, marks or characters capable of being read, which are submitted during the course of the trial. Oral evidence must in all cases be direct: if it is of something that was seen, by the person who saw it; if of something heard, by the person who heard it; if of an opinion, by the person who holds that opinion; or if the knowledge was acquired in any other manner, by the person who perceived it in that manner. The general rule is that hearsay evidence is not admissible. Documentary evidence may be either primary or secondary. Primary evidence of a document is where the document itself is produced for the inspection of the court. When a document has been executed in counterparts, each counterpart is primary evidence against the party executing it, and where a document has been made by printing or any other means that will ensure an exact reproduction, each copy is primary evidence of the other copies, but none of them is primary evidence of the original. Secondary evidence of a document would be counterparts of the document as against the party who did not execute them, copies made from the original and compared with it, office copies, official copies and oral evidence of the contents of a document by a person who has seen the original. Before secondary evidence will be received the party offering it must show a legal reason why the original is not produced, such as being lost, destroyed, in possession of the adverse party who refuses to produce it after notice to do so, or when it is a public document, or when it is in a country or place from which it is not permitted to be removed.

Either oral or documentary evidence may be given of any fact in issue or relevant to the issue; and where two facts are so connected, although one fact is and the other fact is not the issue or relevant to the issue, yet evidence of both may be given if that fact will render probable the existence or non-existence of the

other fact which is in issue or relevant to the issue.

Admissions are statements made by a party to any proceeding and in reference to that proceeding, and they are admissible against the party making them, but not in his favor. Admissions may also be made by an agent, but to bind the principal they must be made by the agent in his regular course of business or employment. If an admission is made after an agreement has been entered into between the parties not to use it as evidence, it is not admissible, nor is it admissible in evidence made under duress. A confession is a statement made by a person charged with a crime stating or suggesting that he committed that crime. If made voluntarily it is admissible as evidence against him, but if made while the person is under any threat or promise which has been given by a person in authority, it is not admissible. Confessions may be made during the course of the trial, but if the question which produced the confession is an improper one, and after the witness had refused to answer it he had been compelled to do so, it is not a voluntary confession and therefore inadmissible. But if he made no objection to answering the question, it is admissible as a voluntary confession. A witness's opinion is received in evidence when it falls under the head of expert testimony; as, when the question is of some science or art, the opinions of persons specially skilled in that art or science are relevant. Any subject on which special study or experience is necessary to the formation of a correct opinion is a science or art. The most frequent illustrations are medical and handwriting experts. Before the testimony of a person called as an expert is received, he must satisfy the court as to his ability to form a correct opinion on the particular subject on which he is to testify. The general rule is that evidence as to a person's character is not admissible unless it is the fact in issue, except in criminal cases, but if a person introduce evidence to show good character, the other side may produce witnesses to show the contrary. All facts should be proved by the best or highest evidence. If a fact can be proved by a written instrument, the writing should be produced and the party alleging a fact must prove it.

In the United States the rules of evidence are laid down by State enactments which apply in State courts in civil cases, and in Federal courts also, in the absence of Federal enactments. There is no bar to the giving of testimony, either of color or nationality. In criminal trials evidence follows common-law rules, as interpreted by the Federal courts, modified by Federal enactments. Consult Chamberlayne, 'Treatise on Evidence' (4 vols., Albany 1911); Greenleaf, 'Treatise on the Law of Evidence' (16th ed., Boston 1899); Stephen, J. F., 'Digest of the Law of Evidence' (7th ed., London 1907); Thayer, 'Preliminary Treatise on Evidence at Common Law' (Boston 1898); Wigmore, 'System of Evidence in Trials at Common Law' (Boston 1904); Mills, 'Theory and Practice of the Law of Evidence' (London 1907).

**EVIDENCES OF CHRISTIANITY**, in favor of its divine origin, may be divided

broadly into two great classes, namely, external evidences, or the body of historical testimonies to the Christian revelation; and internal evidences, or arguments drawn from the nature of Christianity itself as exhibited in its teachings and effects.

Among the earlier Christian apologists were Justin Martyr, Minucius Felix, Tertullian, Origen, Arnobius and Augustine. Their work was continued by the schoolmen during the Middle Ages. In the 16th and 17th centuries the influences of the Renaissance and the Reformation gave rise to a spirit of inquiry and criticism which developed English deism as represented by Herbert and Hobbes in the 17th century, and Collins and Bolingbroke in the 18th. The general position of English deism was the acceptance of the belief in the existence of God, and the profession of natural religion along with opposition to the mysteries and special claims of Christianity. It was in confutation of this position that the great English works on the evidences of Christianity of Butler, Berkeley and Cudworth were written. In France the new spirit of inquiry was represented by Diderot, D'Holbach, and the encyclopædists, who assailed Christianity mainly on the ground that it was founded on imposture and superstition, and maintained by sacerdotal trickery and hypocrisy. No reply of any great value was produced in the French Church, though in the previous age Pascal in his 'Thoughts' had brought together some of the profoundest considerations yet offered in favor of revealed religion. The 19th century was distinguished by the strongly rationalistic spirit of its criticism. The works of such writers as Strauss, Bauer and Feuerbach, attempting to eliminate the supernatural and the mysterious in the origin of Christianity, were answered by the works of Neander, Ebrard and Ullmann on the other side. The historical method of investigation, represented alike by the Hegelian school and the Positivists in philosophy, and by the Evolutionists in science, is the basis of the chief attacks of the present time against the supernatural character of Christianity, the tendency of all being to hold that, while Christianity is the highest and most perfect development to which the religious spirit has yet attained, it differs simply in degree of development from any other religion. Notable among later apologists of Christianity have been Paley ('Natural Theology'), Chalmers ('Natural Theology'), Mansel, Liddon and others, lecturers of the Bampton Foundation; in Germany, Luthardt, Ewald, Baumstark and others. The evidence of the miraculous is not so much insisted on as it was; life and conduct and the fruits of Christian grace make a stronger appeal to the age. Consult Bruce, 'Apologetics' (London 1902); Burton, 'Our Intellectual Attitude in an Age of Criticism' (Boston 1913); Fisher, 'Grounds of Theistic and Christian Belief' (1883, rev. ed., 1902); and 'Manual of Christian Evidences' (New York 1888); Foster, 'The Finality of the Christian Religion' (Chicago 1906); Garvie, 'Handbook of Christian Apologetics' (New York 1913); Robbins, 'A Christian Apologetic' (London 1902); Rowland, 'The Right to Believe' (Boston 1909); Stearns, 'Evidence of Christian Experience' (New York 1891). See **APOLOGETICS; CHRISTIANITY; HIGHER CRITICISM.**

**EVIL, King's.** See SCROFULA.

**EVIL, Origin of,** the subject of extensive theological and philosophical speculation. The difficulty of the question lies mainly in the fact that the existence of evil in the world seems inconsistent with the view that it was created and is maintained by an omnipotent and beneficent creator. The various theories on the subject have all sought to elude this difficulty either by the supposition of some principle of evil equally eternal with that of good, or by regarding evil as having only a relative existence, being a kind of good in an imperfect and immature stage. But the problem remains inscrutable and insoluble.

Perhaps the oldest theory on this subject is that of Parseism, or the religion of Zoroaster, according to which there were two original antagonistic principles, one good (Ormazd) and the other evil (Ahriman). This is the doctrine that is now very often spoken of as Manichæism. In contradistinction to this dualistic theory with reference to the origin of evil stand the Monistic theories of Brahmanism and Platonism. According to the Brahmanic doctrine of the emanation of all things from one original being (Brahma), this original being was regarded as the sole true existence, and the phenomenal world, with all the evils appearing in it, was held to be mere illusion. Similarly Plato held that the good was the essence of all things, and that the evil and imperfect contained in them had no real existence. The theory enunciated by Leibnitz in his 'Theodicée' ('Vindication of God') resembles that of Plato. In that work he assigns to the evil existing in the world created by God, which he holds to be the best of all possible worlds, a merely relative existence; all that we call evil is, he holds, only evil to us because we do not see it in relation to the rest of the universe, for in relation to the universe it is not evil but good, and accordingly cannot be evil in its own nature. The traditional Christian account of the origin of evil is that given in Genesis. In the theology based thereon, Satan, the personal principle of evil, differs from the Zoroastrian Ahriman only in not being co-ordinate with the personal principle of good. Consult Orchard, 'Modern Theories of Sin' (1911); Rashdall, 'Theories of Good and Evil' (1907); Royce, 'Studies of Good and Evil' (1898).

**EVIL EYE.** See SUPERSTITION.

**EVIL-MERODACH,** ē'vil-mē-rō'dāk, king of Babylonia and son of Nebuchadnezzar II. He reigned for less than a year in 561-560 B.C., and was put to death by his brother Neriglissar. His name has been found on some contract tablets. According to 2 Kings xxv, 27 he liberated Jehoiachin, king of Judah.

**EVOLUTE.** The evolute of a curve is the locus of its centres of curvature. The tangents to the evolute will be normals to the curve, if it lies in a plane, and principal normals, if it lies in a three-dimensional space, so that the curve may be traced by the unwinding of a cord stretched along its evolute. A curve is said to be the involute of its evolute. In general, every curve has an infinity of involutes. Different involutes of the same curve are said to be parallel. The equation of the evolute of the plane curve  $y = f(x)$  is obtained

by eliminating  $x$  and  $y$  between the equation of the curve and  $x_1 = x - y' \left[ \frac{1 + (y')^2}{y''} \right]$ ,  $y_1 = y + \frac{1 + (y')^2}{y''}$

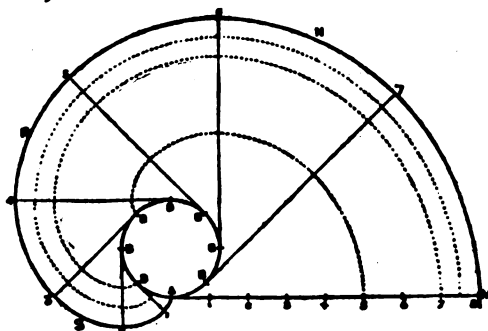

Circle, BBB, as Evolute and its Spiral Involute, MNRSA.

In the geometry of surfaces, the so-called surface of centres corresponds to the evolute. This consists of two sheets, corresponding respectively to the centres of maximum and minimum curvature of the various points of the surface with reference to which it is described. See CURVES; SURFACES, THEORY OF.

**EVOLUTION.** See MAN, CHRISTIAN ANTHROPOLOGY.

**EVOLUTION, History of.** In traversing the history of natural science as in traversing the history of any phase of human thought and activity, we seek constantly for new things, for the precise time of the discovery of the new fact, the announcement of the new idea, the formulation of the new understanding or philosophy. But nothing comes wholly new into the world; the world and its content are all the result of development and growth. So correspondingly very little comes wholly new into history; and the history of evolution is no exception to the rule. The history of evolution clearly reveals that the evolution idea is the result of a long evolution itself; it is impossible to say just when the idea came first into its more primitive form of being, or just when its principal modifications or accretions occurred, or when its present form was finally determined. In tracing the history of the unfolding of the evolution idea we shall find that the conspicuous achievements in connection with it have not been the discovery of absolute newness, but the recognition and determination and general establishment of the important ideas and conception germs among the host offered.

An eminent American naturalist has defined three stages in connection with the discovery of the laws of science: First, a stage of dim suggestion and pure speculation with little reference to facts; second, a stage of the statement of a working hypothesis to explain certain facts; and, third, the proof or demonstration of the law by facts. These stages can be recognized in the history of evolution. The first corresponds with the period of the Greek philosophers; the second with the post-Greek, pre-Darwinian period, and the third with the Darwinian and post-Darwinian period.

The evolution theory was largely anticipated, at least by suggestion, by the Greeks. They

have left writings that can easily be interpreted as more or less clearly outlining the essential conception of organic evolution. Empedocles (493-435 B.C.), for example, who has been called "the father of the evolution idea," believed in spontaneous generation as the explanation of the origin of life, and he believed that different forms of life were not produced simultaneously. Plant life came first and animal life only after a long series of trials, but the origin of the organisms was a very gradual process. "All organisms arose through the fortuitous play of the two great forces of nature upon the four elements. Thus, animals first appeared not as complete individuals, but as heads without necks, arms without shoulders, eyes without their sockets. As a result of the triumph of love over hate, these parts began to seek each other and unite, but purely fortuitously. Thus out of this confused play of bodies all kinds of accidental and extraordinary beings arose." But the unnatural products soon became extinct because they were not capable of propagation. After the extinction of these monsters other forms arose which were able to support themselves and multiply. Thus, if one cares to, one may see in the ideas of Empedocles the germ of the theory of the survival of the fittest, or natural selection.

Aristotle (384-322 B.C.), the greatest of the Greek natural philosophers, believed in a complete gradation in nature, a progressive development corresponding with the progressive life of the soul. Nature, he says, proceeds constantly by the aid of gradual transitions from the most imperfect to the most perfect, while the numerous analogies which we find in various parts of the animal scale show that all is governed by the same laws; in other words, nature is a unit as to its causation. Man is the highest point of one long and continuous ascent. Aristotle perceived a marvelous adaptation in the arrangement of the world, and felt compelled to assume intelligent design as the primary cause of things. Nothing, he held, which occurs regularly can be the result of accident. Aristotle rejected the crude conception of Empedocles of the survival of the adapted, and the extinction of unadapted, beings. "It is impossible that these adapted parts should arise in this manner [of Empedocles]; for these parts and everything which is produced in nature are either always, or for the most part, adaptively produced; and this is not the case with anything which is produced by fortune or chance even as it does not appear to be fortune or chance that it frequently rains in winter . . . As these things appear to be either by chance or to be for some purpose, and we have shown that they cannot be by chance, then it follows that they must be for some purpose. There is, therefore, a purpose in things which are produced by and exist from nature."

The Greeks, taken altogether, suggested more or less crudely the idea of the gradual development of organisms, the idea of the elimination of mistakes in production, and therefore the idea of the survival of the fittest, the idea of the adaptation of parts or the fitness of certain structures to certain ends, the idea of intelligent design constantly operating in nature, as also the idea of nature being controlled by the operation of natural causes due

in the beginning to the laws of chance. After all, however, in how far are we justified in reading into a happy suggestive phrase or sentence of any Greek speculative thinker a real conception of that idea of the origin and development of organic nature that we hold to-day under the name of Evolution?

Following the Greeks the evolution idea was left in the hands of the theologians, natural philosophers and naturalists of the long period from Augustine (1st century A.D.) to the end of the 17th century, a period chiefly ruled by the Mosaic interpretation of the origin of organic life and its variety. Augustine, himself, large-minded man that he was, gave a liberal and naturalistic interpretation of the Mosaic record, favoring potential rather than special creation and teaching that in nature we should not look for miracles, but laws. But opposed to him were almost all the other churchmen, and their rigid adherence to the Mosaic interpretation controlled almost all thinking about life for many centuries. The great Evolution idea lay practically dead from the time of its foreshadowings by the Greeks until the time of the speculative natural philosophers of the 16th and 17th centuries.

Bacon (1561-1626) pointed out the evidence for variation in animals and the bearing of this upon the production of new species and upon the gradations of life forms. Descartes (1596-1650) advocated a strong mechanistic conception of the physical universe and all life within it. Leibnitz (1646-1716) advocated a doctrine of continuity of life forms, and said that the different classes of animals are so connected by gradatory forms that it was practically impossible either by observation or imagination to determine where any one begins or ends. These ideas of continuity in nature were also reiterated and strengthened by Spinoza, Pascal and Newton. It is interesting to note that all these contributions to the establishment of the evolution idea came from the speculative natural philosophers rather than from the naturalists.

Chief among all the natural philosophers who have attempted to express the early idea of evolution was Kant (1724-1804), but he was staggered by the thought that any human investigation could ever reach an understanding of the laws which have governed the derivation of all organic beings from the lowest up to man. "It is quite certain," he wrote, "that we cannot become sufficiently acquainted with organized creatures and their hidden potentialities by the aid of purely mechanical natural principles, much less can we explain them; and this is so certain, that we may boldly assert that it is absurd for man even to conceive such an idea, or to hope that a Newton may one day arise even to make the production of a blade of grass comprehensible, according to natural laws ordained by no intention. Such an insight we must absolutely deny to man."

However, certain naturalists of the 17th and 18th centuries did make their contributions of fact, or alleged fact, to the evolution idea. For example Bonnet (1720-93), who is reputed to be the author of the term "Evolution" in connection with the development of life, is famous for his extraordinary "encasement theory" of embryology, according to which all the future progeny and successive after-generations derived from a

female animal existed in miniature in the eggs in her body, with lesser eggs within the miniature young, containing the next generation, and so on *ad infinitum*.

But it is with the great French naturalist Buffon (1707-88) that the real contribution of naturalists to and participation in the development of the evolution idea importantly begins. He has, indeed, been called by Osborn the naturalist founder of the modern applied form of the evolution theory. But with other historians of evolution, he has no such standing. Radl, for example, says that "the best thing about Buffon is his style." However it may truthfully be said of him that he was the first great naturalist to point out on a broad scale the mutability of species in relation to changes of environment. Very early in his studies of comparative anatomy he found difficulty in the special creation theory. "The pig does not appear to have been formed upon an original special and perfect plan since it is a compound of other animals. It has evidently useless parts, or rather parts of which it cannot make any use, toes, the bones of which are perfectly formed and which nevertheless are of no service to it. Nature is far from subjecting herself to final causes in the formation of her creatures." Buffon believed in the direct modifying influence of environment. "How many species, being perfected or degenerated by the great changes in land and sea, by the favors or disfavours of nature, by food, by the prolonged influence of climate, are no longer what they formerly were." He also fairly clearly expressed the conception of a struggle for existence, an elimination of the least-perfected species and a contest between the fecundity of certain species and their constant destruction. This is anticipating more or less definitely the prodigality of production ideas of Malthus, and the natural selection doctrine of Darwin. But he was not of the stuff of which martyrs are made. When the authorities of the Church called for an explanation of his views he said: "I declare that I have had no intention of denying the Holy Writ; I declare that I firmly believe all that is written there concerning creation, as well concerning the time as the procedure; and I willingly retract whatever is in my book that in any way is contradictory of the Mosaic relation, as I hold my hypothesis concerning the formation of the earth and other planets as a purely philosophical conception."

It is interesting to note the fact that another great naturalist, Linnæus, exactly contemporaneous with Buffon, a botanist, and the first great systematist or classifier of organisms, was an absolute believer in the fixity of species. Species were, in his mind, the units of direct creation; each species bore the impression of the thought of the Creator in all its structure and functions. Later in his life Linnæus did give up, in some little measure, this idea of the special Divine creation and absolute fixity of species. "All the species of one genus," he wrote before his death, "constituted at first a single species, but this subsequently became multiplied by hybrid generations, that is, by intercrossing with other original species."

Following Buffon, the next two most important names to be mentioned in connection with the history of evolution are those of Erasmus Darwin (1731-1802), and Lamarck

(1744-1829). Erasmus Darwin was a poet and naturalist, and the grandfather of Charles Darwin. He was, in his late years at least, a firm evolutionist, with conceptions concerning the factors or causes of evolution strangely like those afterward proclaimed by Lamarck, and quite opposed to those chiefly insisted on by Charles Darwin. After stating his belief that all organisms have been produced by "one and the same kind of living filament," and setting out strong arguments for the mutability of species, he says: "All animals undergo transformations which are in part produced by their own exertions, in response to pleasures and pains, and many of these acquired forms or propensities are transmitted to their posterity." This, according to Osborn, is the first clear and definite statement of the theory of the transmission of acquired characters as a factor of evolution. He provides against the charge of irreverence in substituting evolution for special creation by saying: "If we may compare infinities, it would seem to require a greater infinity or power to cause the causes of effects, than to cause the effects themselves: that is to establish the laws of creation rather than to directly create."

Lamarck may fairly be called the first to set out in detail a full and logical theory of descent with explanations of the causes of this descent. With full justice he is referred to as the most prominent figure in the history of evolution between the Greeks and Charles Darwin. But no one has been more misunderstood nor judged with more partiality by over or under praise. He had as contemporaneous antagonist the great anatomist Cuvier (1769-1832) who gave all the heavy weight of his name and position to the attack on the Lamarckian doctrines in particular and evolution in general. Indeed, Cuvier, though he added enormously to our knowledge of comparative anatomy, almost as enormously hindered the progress and postponed the acceptance of the evolution theory, which actually finds a large part of its proof in the facts of comparative anatomy.

Lamarck's exposition of the evolution theory and particularly of its causes, with the great stress laid upon the principle of the inheritance of acquired characters, and hence the all-important influence and effect of varying environment in the modification of species, has come to be known in evolution literature as "Lamarckism" in contrast with "Darwinism," or Charles Darwin's contribution with its special emphasis on natural selection as the explanation of the "origin of species." "Darwinism" is too often popularly used synonymously with evolution, but it should not be so used. "Darwinism" is a convenient inclusive name for Darwin's explanations of evolution; his theories of natural and sexual selection.

Contemporary with Lamarck were Goethe (1749-1832) who contributed somewhat to the evolution theory by his studies and generalizations on the metamorphosis of plants and the vertebrate theory of the skull, and Saint Hilaire (1772-1844) who maintained insistently the truth of the evolution theory, then being obscured by the antagonism of Cuvier, but who denied the inherited influences of habit, holding that the direct modifying action of environment on organisms was the sole cause of species-forming.

But it was Charles Darwin (1809-82) who

was first able to restore and extend enormously the prestige of the evolution conception. This was due first to his tremendous marshaling of facts to support it, and, second, to his contribution of a new, or practically new, cause-mechanical explanation of species change, or, as usually expressed, "origin of species." It is Darwin's great merit to have wholly re-established the theory of descent and to have offered the first explanation of it that made a really winning appeal to biologists generally. It was also his fortune to bring the evolution conception home to the people. Up to the publication of his 'Origin of Species' (1859) but few persons believed in evolution, and the great mass of the people knew nothing about it.

Part of the general acceptance of Darwin's ideas was due to the polemic ability of various immediate friends and champions of Darwinism among contemporary naturalists. Intimately associated with Darwin and his presentation of the natural selection theory were such men as Huxley, Lyell, Asa Gray, Agassiz and others. Huxley, Lyell and Asa Gray were adherents and defenders of Darwinism, while Agassiz was among the more conspicuous of the antagonists. The actual weight of personal debate and polemic struggle on behalf of Darwin fell largely on Huxley. It could have rested in no better hands. Despite the fact that the time was ripe for Darwin, and despite his extraordinary massing of facts, and his marvelous anticipations and refutations of criticisms, the swift winning of the acceptance of Darwinism was largely due to the championship of Huxley. Haeckel, the great zoologist and bold speculative monist philosopher of Jena, was the principal continental contemporary champion of Darwinism.

A curious incident in the history of the Darwinian evolution exposition and explanation is that of the extraordinary coincidence of the formulation of the natural selection theory by Alfred Russel Wallace at the very same time of its utterance by Darwin. As a matter of fact both men published papers formulating this theory in 1858 in a single number of the *Journal of the Linnæan Society*. The name of Wells (1813), Matthews (1831) and Nandini (1852), are often mentioned as those of men who anticipated in some measure, at the various dates indicated, Darwin's utterance of the selection theory, by more or less clear statements of its essence, but none of them carried conviction to the world.

The post-Darwinian history of evolution has chiefly to do with the further development of the Darwinian theories, together with the rise of the so-called "mutations theory" of species origin, associated with the name of De Vries, as an addition to Lamarck's and Darwin's explanations, and the stressing of the significance of the new knowledge of heredity, beginning with the discovery by present-day biologists of the experimental work and conclusions of Mendel, achieved some 30 years prior to their coming to be generally known. But as these later developments are treated in some detail, together with Lamarck's and Darwin's own theories, in an article elsewhere in this work (see EVOLUTION. THEORIES OF), this sketch of the history of evolution may suitably close with the period of Charles Darwin. The present status of the evolution conception is still that so solidly established by Darwin and his

contemporaries. As to the explanations, or factors, of evolution, also, Darwin's still hold chief place, especially in the minds of the mass of the generally educated people. Among biologists, however, there is a growing tendency to see in the Darwinian selection theories many difficulties formerly unperceived, and to cast about for other aiding or even possibly replacing theories.

**Bibliography.**—Clodd, Edward, 'Pioneers of Evolution, from Thales to Huxley' (New York 1897); Locy, W. A., 'Biology and Its Makers' (New York 1908); Osborn, H. F., 'From the Greeks to Darwin' (New York 1895).

VERNON KELLOGG,  
*Professor of Entomology, Leland Stanford  
Junior University, California.*

**EVOLUTION, Theories of.** In any consideration of the "theories of evolution" there must be kept clearly in mind the distinction between conceptions or theories of the origin or transformation of species and of plant and animal descent generally, and theories offering explanations of the causes and controls of this species, origin and descent. The first is the evolution conception proper, and should be what is primarily meant when the term evolution is used alone. We could still believe in evolution, and recognize it as a great scientific fact, even if we had no wholly clear or generally accepted understanding of the causes that bring it about and the influences that control it. In fact, that is not far from being the actual situation to-day.

But in common usage, and in many books, the fact, or theory, of evolution, and the facts and theories of the causes of evolution are not differentiated. In the minds of naturalists, however, the distinction is usually maintained, and it would be of great advantage if it were more widely and popularly made. For the evolution conception itself is no longer a debated question, whereas the particular methods and, above all, the so-called factors, or initiating and guiding causes of evolution, are still open to debate, and, indeed, are continuously and vigorously debated. When one reads of disagreements among biologists concerning the merits of "Darwinism," it is not a disagreement concerning the fact of evolution, for which the term "Darwinism" is too often synonymously used in popular writing and speaking, but it is a disagreement concerning the value of Charles Darwin's explanation of the causes of evolution, namely, his theories of natural and sexual selection.

However it is hardly possible to consider the general theory of evolution apart from theories of its cause and control, and the subject of this article, which for the sake of brevity, is written simply as "theories of evolution," is really meant to cover a discussion of theories which explain evolution; how it comes to be, what its methods are, and what are its causal factors.

In earlier days, the days of the Greeks and the later churchmen and natural philosophers of the middle centuries, there were various different theories of evolution, if the incomplete and often fantastic speculations of these times can be called theories. Some of these are outlined in the article EVOLUTION, HISTORY OF. But the real struggle from the beginning of serious thinking about the multitude and variety of

plant and animal forms up to the time of the publication of Darwin's 'Origin of Species' (1859) and the few years thereafter, when its heretical doctrine was getting firmly established among scientific and educated men the world over, was between the believers in special creation of all these forms and believers in their origin by evolution.

To-day there is not a biologist of standing who does not accept the theory, or better, fact, of evolution. And the great majority of all people who think about the matter at all also accept this once ultra-heretical and scoffed-at doctrine.

The explanatory theories of evolution are numerous; some of them are not readily distinguishable from one another; they overlap more or less; but a number of fairly well-contrasted different theories can be made out when careful analysis is made of the whole group. Each of these is distinguished by the emphasis which it gives to some one factor and the subordination or even total rejection of other factors particularly stressed in other theories.

These various distinguishable theories can be grouped into several categories, such as those which are essentially vitalistic as compared with those essentially mechanistic in their explanation; or those which envisage species-forming as proceeding by little leaps as contrasted with those which assume perfect gradation and continuity in species. Some of the theories are based on the assumption of individual change in response to the environment and personal habit, and the inheritance of these "acquired characters." Others reject this possibility *in toto*, or partially, and stress the effect of a selection among strictly germinal inheritable variations based on a rigorous struggle for existence which extinguisches the possessors of disadvantageous variations and preserves the lucky possessors of advantageous ones, thus leaving only these latter to leave progeny, which will naturally inherit the fortunate characteristics of the parents. Some see the germinal variations, which in all modern theories are the basic elements of evolution, produced purely by chance, while others see them as the determined results of the influence of an inner directing force, or of the outer environment.

Only the more important and more strongly contrasted of these theories need be described. For most are but changes rung on a few principal themes. Lamarckism and Neo-Lamarckism as contrasted with Darwinism and Neo-Darwinism; Vitalism as contrasted with the Mechanicalism; and Chance as contrasted with Determinism; these are the chief points that need to be taken into account in differentiating the various explanations of the phenomena of organic evolution.

Despite the suggestiveness of the many Evolution and Evolution-explaining speculations made by various natural philosophers and naturalists before the beginning of the 19th century, it was not until Lamarck, in the very first years of said century, began to express his view of evolution and its causes, that a full and logically constructed evolution theory may be said to have been formulated. The nearest approach to such an earlier formulation was that made in the late years of the 18th century by Erasmus Darwin, grandfather of Charles Darwin. "A rapid run through the later writings of Dr. Dar-

win," says Clodd, "shows that there is scarcely a side of the great theory of evolution which has escaped his notice or suggestive comment." While Grant Allen notes that the theory of natural selection, which was Charles Darwin's great contribution to the evolution conception, was the only cardinal one in the evolutionary system on which Erasmus Darwin did not actually forestall his more famous and greater grandson.

**Lamarck and the Lamarckian Theories.**—Jean-Baptiste-Pierre-Antoine de Monet, Chevalier de Lamarck, born in 1744 in the village of Bazentin in Picardy (northeast France), was in 1800 professor of invertebrate zoology in the Museum of Natural History in Paris. He had previously been for many years keeper of the herbarium in the Museum. He was, therefore, well grounded in the facts of both botany and zoology, and he had a philosophical mind, which, in the face of the facts of science learned by him, compelled him to turn from the orthodox view of creation by special design and act to the heretical one of evolution. In the opening lecture of his professional course in the year 1800 he outlined his views and his theory of the method and cause of evolution. Later he exposed his theory at length and in full detail in his famous 'Philosophie Zoologique' (1809).

The essential feature in the explanation of descent conceived and uttered by Lamarck is the inheritance of acquired variations. Lamarck was convinced, first, of the certainty that species vary under changed external influences, second, that there is a fundamental unity in the animal kingdom, and, third, that there is a progressive development. The main influences that tend to change species come under the law of use and disuse, for he believed that nature does not effect her changes directly (Buffon's belief) but through the reaction of animals to their environment. Lamarck denied, absolutely, the existence of any perfecting tendency in nature, and regarded evolution as the final necessary effect of surrounding conditions on life.

Thus, instead of suggesting that animals had been created for a certain mode of life, he supposed that their mode of life had itself created them. "In considering the natural order of animals, the very positive gradation which exists in their structure, organization, and in the number as well as the perfection of their faculties, is very far removed from being a new truth, because the Greeks themselves fully perceived it; but they were unable to expose the processes and proofs of this evolution because they lacked the knowledge necessary to establish it. In consideration of this gradation of life, there are only two conclusions which face us as to origin: *The conclusion adopted up to to-day:* Nature (or its Author) in creating animals has foreseen all possible sorts of circumstances in which they would be destined to live, and has given to each species a constant organization, as well as the form, determined and invariable in its parts, which forces each species to live in the places and climates where it is found, and there preserve the habits which we know belong to it. *My personal conclusion:* Nature, in producing successfully all the species of animals, and commencing by the most imperfect or the most simple to conclude its labor in the most

perfect, has gradually completed our organization; and of these animals, while spreading generally in all the habitable regions of the globe, each species has received, under the influence of the environment which it has encountered, the habits which we recognize and the modifications in its parts which observation reveals in it."

The following is Lamarck's statement or explanation of the causes of this descent: "First Law: Life by its internal forces tends continually to increase the volume of every body that possesses it, as well as to increase the size of all the parts of the body up to a limit which it brings about. Second Law: The production of a new organ or part results from a new need or want, which continues to be felt, and from the new movement which this need initiates and causes to continue. Third Law: The development of organs and their force or power of action are always in direct relation to the employment of these organs. In every animal which has not passed the term of its development the more frequent and sustained employment of each organ strengthens little by little this organ, develops it, increases it in size, and gives it a power proportioned to the length of its employment; whereas the constant lack of use of the same organ insensibly weakens it, deteriorates it, progressively diminishes its powers and ends by causing it to disappear. Fourth Law: All that has been acquired or altered in the organization of individuals during their life is preserved by generation (heredity), and transmitted to individuals which proceed from those which have undergone these changes."

**Neo-Lamarckian Theories.**—Lamarck's theory was a simple and well-constructed one, and one which, if based on established fact, would furnish the most satisfying explanation of evolution yet offered. But its great fault is that the basic assumption in the theory is not an established fact; indeed, it seems to be just opposed to the facts. Despite a few plausible cases, about which a great storm of argument has raged—for example, the famous controversy in 1893 and 1894, in the *Contemporary Review*, between Herbert Spencer, champion of Lamarckism, and August Weismann, its most destructive antagonist—most naturalists agree that the known facts of inheritance not only do not support but strongly deny the Lamarckian assumption of the heritability of characters acquired by an individual in its lifetime by reaction to environment, use or disuse of parts, and personal habit.

And yet there have always been, and are today, biologists of the very first class who believe in most of the essentials of the Lamarckian explanation of evolution as opposed to the Darwinian. Their principal reasons for this belief are: First, the radical assumptions as to almost limitless time, rigor of the struggle for existence and actual validity of the minute, fortuitous, germinal variations as determining elements in this struggle, and the necessary extreme variety of these variations, that have to be made in connection with Darwin's selection explanation in order to get such results out of chance as are revealed in the extraordinarily fine and perfect adaptations of plants and animals to their environment.

Second, it has been shown by the experi-

ments of Klebs, Tower and others, that the environment *can* sometimes affect the germ-cells, and that when it does it can actually produce changes in the next generation that are inheritable, although it must be said that these changes are not necessarily adaptive.

Third, it is a fact of familiar observation that the adaptations of species are often almost exactly of the same character as the changes that are produced in individuals by their immediate reaction to environment conditions, and on this the assumption is made that despite our lack of any knowledge of how this individual change is impressed on the germ-cells, and even in face of our greatly advanced understanding of the mechanism of inheritance, almost all of which goes to indicate the independence of the germ-cells from external influences affecting the body-cells, this parallelism must in some way be the result of an inheritance of acquired characters.

For these reasons and others, therefore, there is a school of biologists, who may be called Neo-Lamarckians, which is busy formulating modifications of the old Lamarckian theory to make it fit our more recent knowledge of facts.

**Charles Darwin and the Darwinian Theories.**—In a paper presented to the Linnæan Society of London in 1858, and far more fully and elaborately in the 'Origin of Species' published in 1859, Charles Darwin, born in 1809, in Shrewsbury, England, and bearing, without any question, the most distinguished name in all the long roll of names associated with the evolution conception, presented an explanatory theory of species-forming and descent which is best known as the Selection Theory.

This Darwinian explanation rests on certain observed facts and certain inductions from these facts. The observed facts are: (1) the increase by multiplication in geometrical ratio of the individuals in every species, whatever the kind of reproduction which may be peculiar to each species; (2) the always apparent slight (to greater) variation in form and function existing among all individuals even though of the same generation or brood; and (3) the transmission, with these inevitable slight variations, by the parent to its offspring of a form and physiology essentially like the parental. The inferred (also partly observed) facts are: (1) a lack of food and room for all these new individuals produced by geometrical multiplication, and consequently a competition (active or passive) among those individuals having any æcologic relations to one another, as, for example, among those occupying the same locality, or needing the same food; (2) the probable success in this competition of those individuals whose slight differences (variations) are of such a nature as to give them an advantage over their confères, which results in saving their lives, at least until they have produced offspring; and (3) the fact that these "saved" individuals will, by virtue of the already referred to action of heredity, hand down to the offspring their advantageous condition of structure and physiology.

The competition among individuals and kinds (species) of organisms may fairly be called a struggle. This is obvious when it is active, as in actual personal battling for a piece of food or in attempts to capture prey or to escape



capture, and less obvious when it is passive, as in the endurance of stress of weather, hunger, thirst and untoward conditions of any kind. The struggle is, or may be, for each individual threefold in nature: (1) an active struggle or competition with other individuals of its own kind, for space in the habitat, sufficient share of the food, and opportunity to produce offspring in the way peculiar and common to its species; (2) an active or passive struggle or competition with the individuals of other species which may need the same space and food as itself, or may need it or its eggs or young for food, and (3) an active (or more usually passive) struggle with the physico-chemical external conditions of the world it lives in, as varying temperature and humidity, storms and floods and natural catastrophes of all sorts.

The resultant of these existing conditions is, according to Darwin and his followers, an inevitable natural selection of individuals and of species. Thousands must die where a few may live to maturity (i.e., to the time of producing young). Which 10, say, of the thousand shall live depends on the slight but sufficient advantage possessed by 10 individuals in the complex struggle for existence due to the fortuitous possession of fortunate congenital differences (variations). The 990 with unfortunate congenital variations are extinguished in the struggle and with them the opportunity for the perpetuation (by transmission to offspring) of their particular variations. The offspring of the 10, of course, will vary in their turn, but will vary around the new and already proved advantageous parental condition: among the thousand, say, offspring of the original saved 10 the same limitations of space and food will again work to the killing off before maturity of 990, leaving the 10 best equipped to reproduce. This repeated and intensive selection leads to a slow but steady and certain modification, through the successive generations, of the form and functions of the species; a modification always toward adaptation, toward fitness, toward a moulding of the body and its behavior to safe conformity with external conditions. The exquisite adaptation of the parts and functions of the animal and plant as we see it every day to our infinite admiration and wonder has all come to exist through the purely mechanical, inevitable weeding out and selecting by nature (by the environmental determining of what may and what may not live) through uncounted generations of unreckonable time.

Associated with this theory of natural selection Darwin also advanced a theory to account for the often marked differences between the sexes of a species, involving the possession by one sex, usually the male, of special outgrowths of the body, bright and heavy plumage, or conspicuous colors and pattern, etc., most of which would seem to be elements of disadvantage rather than advantage in the struggle for life. Darwin's explanation of this, called the theory of sexual selection, was that these characters are of advantage in the rivalry of mating, many of them being apparently of a kind to attract and excite individuals of the opposite sex. Hence they might help their possessors win in the struggle to find mates and consequently to leave progeny. It is a sort of particular and limited kind of natural

selection, not involving a determination between life and death, but one between going childless and leaving posterity—which is, after all, the essential determination in natural selection. But the assumed fact of choice in this theory of sexual selection involves various unproved and hardly probable assumptions regarding the esthetic development of birds, butterflies, spiders, etc., and has been strongly attacked both on the basis of actual opposing observation and experiment as well as on the basis of general improbability. On the whole, Darwin's theory of sexual selection has been largely discredited, although it must be said that no very satisfactory substitute explanation has been offered for it. But this discrediting of sexual selection throws a heavier strain on the theory of natural selection, for it was to relieve the latter theory of the difficulty of facing these apparently existing disadvantageous characters of the males of many species of birds and insects that the sexual selection theory was devised.

Nevertheless it is true that Darwin's natural selection explanation of evolution has been, ever since its announcement, more widely and authoritatively accepted as the needed revelation of the causes and methods of species-forming and adaptation than any other explaining theory yet offered.

**Neo-Darwinian Theories.**— Darwin never claimed for natural selection that it was the only influence capable of modifying species and explaining descent. But some of his followers have practically made that claim. Most notable among these Neo-Darwinians was August Weismann, professor of zoology at Freiburg in Baden, whose strenuous attacks on the conception of the inheritance of acquired characters did so much to discredit the Lamarckian explanation of evolution. Weismann's theories of heredity led him to a belief in the almost absolute isolation in the body, and hence independence from influences affecting it, of the germ-cells, and the consequent belief that the only variations that could be possibly inherited were the minute germinal ones that served Darwin as the basis for the working of natural selection. From this to a belief in the *All-Macht* of natural selection in determining species-change and descent generally was but the natural step.

Alfred Russell Wallace and some other prominent English naturalists ranged themselves with Weismann as Neo-Darwinians. Most American naturalists, however, held aloof from this extremist attitude, while the Germans were divided. In the later years of his life, Weismann withdrew from his original most advanced position, and was inclined to admit the inadequacy of natural selection as an all-sufficient explanation of descent.

**Isolation Theories.**— One of the most valid criticisms of the natural selection theory has been that it makes it necessary to ascribe a life-and-death determining value to the small germinal variations which are the basis of the selective working of the struggle for existence, and it has always seemed hard in the face of the very trivial character of many of these little differences to admit this value for them. But there is one way in which it seems that these little differences might be heaped up and developed into larger ones in the course of successive generations, and that is by the isolation

from the main body of the species of a group of individuals more or less similar in germinal characters. This isolation could be effected by a migration and later geographic segregation of a group. The result would be an enforced inbreeding and an elimination of the swamping effects of unrestricted wider crossing. The result would be a cumulation of the characteristics represented in the group by originally minute germinal variations.

Beginning with Moritz Wagner (1868), energetically supported by Romanes (1897), and now most conspicuously urged by David Starr Jordan, this "isolation theory" has been much in favor with some biologists, especially those who pay especial attention to the relation of geographic distribution of plants and animals to evolution.

**Theories of Orthogenesis.**—As the character of the original small germinal variations necessarily first determines the possible lines along which species change and descent proceed; and as it is evident from careful study of the actual lines of descent exhibited both by the many living groups of animals and plants and also the many extinct ones (made visible to us by their fossils) that descent has actually proceeded along certain distinct lines and has not been scattered miscellaneous and futilely in all directions, it is plain that the discovery of any cause or form of control which would direct variation in certain more or less definite directions would help very much in solving the great problem of the cause and control of evolution.

From the beginning, therefore, the existence of such means, and its character, have been sought for. Many biologists have believed that the phenomenon of evolution can only be explained by the assumption of such a means. Cope, an American paleontologist—and it may be noted that paleontologists, from their studies of the long succession of life through many millions of years seem especially inclined to this belief—about 1870, attributed to the simplest life-stuff a sort of primitive consciousness which gives it a capacity for adaptation and modification that results in definite orthogenetic evolutionary advance. Naegeli, a great German botanist and natural philosopher, proposed in 1884 a theory of orthogenesis (evolution in fixed lines) by assuming the existence of an inner perfecting principle, inherent in all organisms, which determine the general lines of variation and makes steadily toward evolutionary progress.

Both these theories are essentially vitalistic in character in that they assume an inner mystic something associated with life and characteristic of it that can direct its evolution, which makes it unnecessary and futile to try to find a more mechanical or physico-chemical explanation of this capacity of living matter. More modern exponents of this vitalistic belief are such men as Driesch and Bergson, who may be called Neo-Vitalists.

Eimer, a German zoologist, in 1888 denied the vitalistic, automatic inner perfecting principle of Naegeli, but upheld the assumption of orthogenetic evolution, attributing its cause to the direct influence of extrinsic and environmental conditions. A number of English biologists, as Henslow and Lloyd Morgan, have ranged themselves in the ranks of the believers

in orthogenesis, but they have not cared to admit the existence of any peculiar vitalistic factor as its explanation. The present dean of American paleontologists and evolutionists, H. F. Osborn, is also, on the basis of his extensive studies of evolutionary progress among extinct animals, especially the mammals, a believer in orthogenesis, but he is content to attribute its cause to some as yet "unknown factors of Evolution." It is also true that under the influence of modern discoveries in connection with the mechanism and methods of heredity there is a strong tendency among many modern biologists to lean more and more toward an assumption of an internal cause and control of variation concerning the action of which little can be prophesied and about the character of which little is known.

**Theories of Heterogenesis and Mutations.**—All of the theories of the causes of evolution so far referred to agree in assuming a progress mostly by small, continuous change, so that species form series of perfect gradations. But there have always been naturalists to deny this assumption and to claim that change comes often by definite leaps, so that even the original differences may be fairly large and fixed from the beginning. Such naturalists have formulated a number of theories of heterogenesis or mutancy. Von Koelliker, a German zoologist, proposed, in 1864, such a theory, but only in most general terms. The American naturalist, Dall, in 1877, expressed his conviction that sudden changes of species-forming character sometimes occur in animals, and Francis Galton, the great English anthropologist and cousin of Charles Darwin, and in most of his beliefs a thorough Darwinian, nevertheless denied that the original germinal variations must necessarily be small, referring to the many known cases of "sports" among animals and plants as examples of original differences appearing as leaps.

In 1899, Korschinsky, a Russian botanist, advocated an explanation of species-forming by heterogenesis as one to be preferred to Darwin's selection theory, which he strongly opposed. However he presented few new facts bearing on the subject and made no particular impression on biologists. In 1901, however, the Amsterdam botanist, Hugo de Vries, published the first volume of a large work called 'The Mutations Theory,' in which he described his observations and experiments, extending over many years, on certain plant species, especially the evening primrose, *Oenothera lamarckiana*, and definitely proposed a theory of the origin of species by mutations, or sudden new fixed changes, the new forms thus formed having no special relation, as regards their origin, to adaptation or the struggle for existence. He backed up his theory with a description of many such new "elementary species" which had arisen suddenly under his eyes from the evening primrose.

De Vries' theory has had a large attention and a considerable acceptance from naturalists, especially with those already dissatisfied with the Darwinian explanation. However, despite much observation and experimentation by other men, few other "mutations" besides those described by De Vries have been recorded, while as a general explaining theory of evolution the mutations theory leaves much to be desired.

It is especially helpless in the face of the necessity of explaining adaptation, and adaptation is as characteristic of evolution as is species-change.

**Influence of the Modern Knowledge of Heredity on Theories of Evolution.**—In 1900 three European botanists working independently at problems of inheritance in plants discovered that certain similar work done a third of a century before in the gardens of an Augustinian cloister in Brunn (Austria) by a monk named Gregor Mendel, had been quite overlooked by naturalists and yet was of the utmost importance. This discovery of Mendel's work by the botanists De Vries, Correns and Tschermak, and their independent discoveries, at the same time, of facts confirming Mendel's earlier results, marks the beginning of the modern study of heredity whose positive results already amount to more than had been learned in all time before.

A general summation of these results and consideration of their bearing on the validity of the various theories for the explanation of evolution, lend much weight to the type of theory that assumes the original variations to be the result of influences working from within rather than without. The modern knowledge of heredity also is strongly opposed to any assumption of the inheritance of acquired characters and emphasizes the strictly germinal character of all variations that really count in species-making. As has recently been said by Davenport, a leading American exponent of Mendelism, "a theory of Evolution that assumes internal changes chiefly independent of external conditions, i.e., spontaneously arising . . . seems best to meet the present state of our knowledge" [of heredity]. And he admits that the thorough-going accepters of Mendelism and the new heredity generally are driven to a position as regards the causes and fundamental control of evolution which is essentially like Naegeli's vitalistic theory of evolution from within by virtue of a perfecting or progressive tendency; which is an idea that goes back to Aristotle and includes Huxley and Bergson in its roll of adherents. In other words the most modern theory in explanation of evolution is essentially both anti-Lamarckian and anti-Darwinian, and allies itself with that type of explanation which may be called orthogenetic and vitalistic.

**Bibliography.**—Kellogg, V. L., 'Darwinism Today' (New York 1907); Morgan, T. H., 'Evolution and Adaptation' (New York 1903); Morgan, T. H., 'A Critique of Evolution' (New York 1917); Osborn, H. F., 'The Origin and Evolution of Life' (New York 1917); Packard, A. S., 'Lamarck, His Life and His Work' (New York 1901); de Vries, H., 'Species and Varieties' (New York 1905); Weismann, August, 'The Evolution Theory,' (2 vols., London 1904).

VERNON KELLOGG,

Professor of Entomology, Leland Stanford Junior University, California.

**EVOLUTION IN MATHEMATICS.** See INVOLUTION AND EVOLUTION.

**EVOLUTIONS, Military,** the movements by which troops change formation, position or order. See TACTICS, MILITARY.

**EVONYMUS,** *ev-on'i-mus*, a genus of the staff-tree family (*Celastraceæ*), comprising about 120 species of shrubs, natives of the north temperate zone. Three species are found in America. The best known are the strawberry bush (*E. americanus*), the burning-bush or wahoo (*E. atropurpureus*), and the spindle-tree (*E. europæus*). (See SPINDLE-TREE). From the bark of the wahoo or burning-bush an extract known in medicine as euonymin is obtained. It is used as a cholagogue, tonic and diuretic, and for its stimulant action on the liver.

**EVORA,** *ã'voo-rã* (ancient EBORA), city, Portugal, capital of the province of Alemtejo, 75 miles east by south of Lisbon. It is a very ancient city; Quintus Sertorius took it in 80 B.C., and it was also conquered by the Moors in 715, but recovered from them in 1139. Among the famous Roman antiquities of Evora are the temple of Diana, with fine Corinthian columns; an aqueduct erected by Quintus Sertorius and restored in the 16th century, which still supplies the city with water; and the beautiful tower, surrounded by Ionic columns, at the extremity of the aqueduct, and which, although it has existed since 70 B.C., is in almost perfect preservation. It has an archiepiscopal library, containing, besides some 25,000 volumes, several pictures of great merit. There are iron furnaces and some manufactures of cotton cloth and hats, and a considerable trade in wine. Pop. 17,901.

**EVREMOND,** *ãvr-môn*. See SAINT EVREMOND.

**EVREUX,** *ãvrè* (ancient CIVITAS EBURVICUM), France, the capital of the department of Eure, on the Iton, 57 miles west by northwest of Paris. It is one of the oldest towns of France and its ruins and existing ancient Norman buildings show its antiquity. The most noted of the buildings are the church of Saint Taurin; the bishop's palace, dating back to 1484; the Tour de l'Horloge, built in the same century. The history of the town has been of the same tumultuous order as that of many other towns in that section of France, having been taken from the Romans by Clovis; the Normans under Rollo pillaged the town in 892; Henry I of England captured it in 1119, laying it in waste by fire; Philip Augustus of France took it in 1194 and in 1199; and during the wars of the 15th century between the French and English it was the scene of many bloody conflicts, being passed from the control of one to the other many times. The principal manufactures are machinery, linen, hosiery, leather, tiles and bricks. Pop. (of the commune) 18,957.

**EWALD,** *ãvãl*, Carl, Danish novelist: b. Schleswig 1856; d. 1908. He was educated at the University of Copenhagen, to which city his family had removed after his native province had fallen to the Germans in 1864. After spending some years as a forester, he turned to literature in 1887, at first issuing school texts and translations. His principal original works are 'Singleton's Udenlandsrejse' (1894) 'Glaede over Danmark' (1898); 'Sulasmiths Have' (1898); 'Der Kinderkruezzug' (1896); 'Mein Kleiner Junge' (1899); 'Crumlin' (1900). Several of his works have been translated into English.

**EWALD, Georg Heinrich August**, gä-örg hin'riih ow'goost ä'vält, German Orientalist and biblical critic: b. Göttingen, 16 Nov. 1803; d. there, 4 May 1875. As a student he published his first critical work, 'Die Komposition der Genesis.' He became professor of theology at Göttingen in 1831, and in 1835 professor of Oriental languages. As one of the seven professors of Göttingen who signed the protest against the abrogation by King Ernest Augustus of the Hanoverian constitution, he was deposed from his chair and accepted, in 1838, a call to Tübingen as professor of philosophy. In 1841 he was ennobled by the king of Württemberg and returned in 1848 to Göttingen, and resumed his old position. When Hanover was annexed by Prussia in 1866 he became a zealous defender of the rights of the ex-king and this led to his removal from his university chair, though his salary was continued. He was elected several times a member of the Diet, where he spoke strongly in favor of the restoration of the Hanoverian monarchy. His 'Kritische Grammatik der hebräischen Sprache' (Critical Grammar of the Hebrew Language) (1827), afterward merged in his 'Ausführliches Lehrbuch der hebräischen Sprache,' and continually enlarged (8th ed., 1870), formed an epoch in the study of Hebrew and placed Ewald in the first rank among scholars. 'Das Hohe Lied Salomos' (The Song of Solomon); 'Die poetischen Bücher des Alten Bundes' (The Poetical Books of the Old Testament); 'Die Propheten des Alten Bundes,' containing a translation and interpretation of all the prophets in chronological order; together with his 'Geschichte des Volkes Israel' (History of the People of Israel); and 'Die Alterthümer des Volkes Israel' (The Antiquities of the People of Israel), are his principal works on the Old Testament.

The 'History of Israel' is considered his greatest work, entailed a labor of 30 years and is a work of rare genius stamped with the impress of its author's individuality. Like others of his more important writings, it has been translated into English. On the New Testament he wrote, among other works, 'Uebersetzung und Erklärung aller Bücher des Neuen Testaments' (Translation and Explanation of all the Books of the New Testament). Another important work is 'Die Lehre der Bibel von Gott, oder Theologie des Alten und Neuen Bundes' (the Doctrine of the Bible regarding God, or Theology of the Old and New Testaments). He also wrote philological treatises on various Eastern languages and on subjects connected with them, among which may be mentioned works on the book of Enoch, on Phœnician inscriptions, on Phœnician views regarding the creation of the world, on Arabic Grammar, and 'Linguistic Studies.' From 1849-65 he issued a serial almost entirely written by himself called 'Die Jahrbücher der biblischen Wissenschaft' (Year Books of Biblical Science). Ewald has been called the "second founder of the science of the Hebrew language." Consult Cheyne, 'Founders of Old Testament Criticism' (London 1893).

**EWALD, or EVALD, Johannes**, yō-hän'nēs, Danish poet: b. Copenhagen, 18 Nov. 1743; d. there, 17 March 1781. At 15 he ran away and enlisted in the Prussian service. Being compelled to join a regiment of artillery at Magdeburg, instead of being attached to the hussars

as he had been promised, he deserted the Prussian standard in the Seven Years' War, and entered the Austrian service. After a few months he again deserted, returned home and began to apply himself seriously to theology. On the death of Frederick V of Denmark he was requested to compose an elegy (1766); and the general admiration with which it was received roused his ambition and he soon became one of the most eminent lyric and tragic poets of his nation. His opera the 'Death of Balder' (1774), the subject of which is taken from the northern mythology and his 'Rolf Krage' (1770), a tragedy taken from the ancient history of Denmark, are works which, notwithstanding many defects, bear the impress of true genius; but by some his lyrical drama 'The Fishers' (1779), in which is included the Danish national hymn, is ranked as the finest of all his works. As a lyric poet he is most popular at the present day, and several of his odes and elegies are among the best that modern times have produced. Consult Jorgensen, 'Johannes Ewald' (1888).

**EWART, ū'ärt, David**, Canadian architect: b. Scotland, 1843. He received his education at the Edinburgh School of Arts, removed to Canada in 1871 and became assistant engineer and architect in the Department of Public Works at Ottawa, rising to the post of chief architect in 1897. He completed the central tower of the Parliament buildings at Ottawa and erected the Canadian buildings at the Chicago World's Fair in 1893 and at the Paris Exposition of 1900. He is a member of the board of assessors of the departmental buildings at Ottawa since 1906 and since 1909 is councillor of the Royal Architectural Institute of Canada.

**EWART, James Cossar**, British zoologist: b. Penicuik, near Edinburgh, 26 Nov. 1851. He was educated at Edinburgh University, where he graduated M.D., and was appointed demonstrator of anatomy 1874. In '875 he became conservator of the museum, University College, London; in 1878 professor of natural history, Aberdeen University; and in 1882 professor of the same, Edinburgh University, when he was also appointed member of the Scottish Fishery Board. In London he made researches into the bacillus of splenic fever, etc., and at Aberdeen founded the first marine laboratory in Britain, where, with the late Dr. Romanes, he made researches into the locomotor system of the echinoderms, which was the subject of the Croonian lecture of the Royal Society 1881. He conducts the fishery investigations into the fertilization and life history of the herring, white-bait and other food-fishes and directs a large corps of assistants in the work at various stations. He established lectureships in his university in embryology and the philosophy of natural history and organized, for the students, a union. At Penicuik he has conducted the costly experiments, with which his name is widely known, into the development of the horse, and hybridizing of equine species, including the quagga, zebra and island pony, in different ways; and disproved the hoary theory as to the influence of previous impregnation (telegony). Among his publications are 'The Electric Organs of Skate' (1888-89); 'The Cranial Nerves and Lateral Sense Organs of Elasmobranchs' (1889); 'The Development of

the Horse' (1894); 'Telegony and Reversion' (1887); 'A Critical Period in the Development of the Horse' (1889); 'Guide to Hybrids' (1900); 'The Multiple Origin of Horses and Ponies' (1904); 'Horse Skulls from the Roman Fort, near Melrose' (1906); 'On a Prejvasky Hybrid' (1907).

**EWART, John Skirving**, Canadian lawyer: b. Toronto, 1849. He received his education at Upper Canada College and was admitted to practice in 1871. He practised in Toronto until 1882, when he removed to Winnipeg. He came to Ottawa in 1904 and was now recognized as a leader in his profession. During the contest for separate schools in Manitoba he represented the Catholic side. He became interested in political questions after 1900 and opposed the aims of the imperialists. At The Hague court in 1910 he was chief counsel for Canada. He published reports of cases in the courts of Manitoba from 1883 to 1890 and also 'The Kingdom of Canada and Other Essays' (1908); 'Sir John Macdonald and the Canadian Flag' (1908); 'Canadian Independence' (1911); 'The Kingdom Papers' (1912).

**EWART, William**, English physician: b. London, 1848. He received his education at the University of Cambridge and also at Paris and Berlin. He became consulting physician to many hospitals and examiner and lecturer to the Royal College of Physicians. He was assistant physician to the Brompton Hospital for Consumption. He became a recognized authority on the diseases of the heart and lungs. His works include 'Pulmonary Cavities' (1882); 'Cardiac Outlines' (1892); 'Heart Studies, Chiefly Clinical' (1894); 'Bronchitis,' and 'Bronchiectasis' (in Allbutt and Rolleston's 'System of Medicine,' London 1909), and a portion of 'Report on Climates and Baths of Great Britain' (issued by the Royal Medical and Chirurgical Society, Vol. II, 1902).

**EWBANK, ū'bank, Thomas**, American scientist: b. England, 11 March 1792; d. New York, 16 Sept. 1870. He came to America about 1819 and engaged in manufacturing metallic tubing (1820-36). He was United States commissioner of patents 1849-52. His publications include 'The World a Workshop' (1855); 'Life in Brazil,' with an appendix on a collection of American antiquities (1857); 'Reminiscences in the Patent Office' (1859); 'Thoughts on Matter and Force' (1858); and 'Inorganic Forces Ordained to Supersede Human Slavery,' an essay.

**EWE**, a linguistic negro stock, inhabiting the coasts of Dahomey and Togoland. It is probable that they came from Borgu or Gurma only a few centuries back. They are agriculturists and possess a highly developed juridical system. They comprise the Awuna, Ataklu, Agbosimi, Afiao, Geng, Togo, Krikor, Ewemi, Fra, Dahoman, Mahi, Aja, Affakpami and others. Consult Ellis, 'The Ewe-Speaking Peoples of the Slave Coast of West Africa' (London 1890); Stanford 'Africa' (ib. 1895).

**EWELL, ū'el, Arthur Woolsey**, American physicist: b. Bradford, Mass., 1873. He was educated at Yale where he was graduated in 1897, and also studied at the universities of Johns Hopkins and Berlin. From 1897 to 1910 he was instructor in physics and assistant pro-

fessor at the Worcester Polytechnic Institute, becoming professor in 1910. He is a Fellow of the American Academy of Arts and Sciences and has published 'A Textbook of Physical Chemistry' (1909); 'Physical Measurements' (1910; 2d ed., 1913); 'Artificial Rotatory Polarization' (1911).

**EWELL, Benjamin Stoddert**, American educator: b. Washington, D. C., 10 June 1810; d. James City, Va., 19 June 1894. He was graduated at West Point 1832, taught mathematics there until 1836, and later served as assistant engineer of the Baltimore and Susquehanna Railroad, becoming professor of mathematics at Hampden-Sidney College 1839, where he remained till 1846. He filled a similar chair at Washington University, Lexington, Va., 1846-48, when he went in the same capacity to William and Mary College, becoming its president 1854, and president emeritus 1888. He was in command of the 32d Regiment, Virginia Volunteers, from 1861-62 and adjutant-general of the Confederate army on the staff of Gen. Joseph E. Johnston, when he was commander of the departments of Tennessee and Mississippi 1862-64.

**EWELL, Marshall Davis**, American lawyer: b. Oxford, Mich., 18 Aug. 1844. He was graduated at the University of Michigan Law School (1868), and was professor of common law in the Union College of Law, Chicago, from 1877 until the founding of the Kent College of Law, in which he became professor of common law, dean and president. He is well known as a microscopist and handwriting expert, and was elected a Fellow of the Royal Microscopical Society of London (1886), and president of the American Microscopical Society (1893). He has edited 'Blackwell on Tax Titles' (1875); 'Illinois Reports' (Vols. XXXII-XXXVI, inclusive, 1877); 'Washburn's Manual of Criminal Law' (1878); 'Evans on Agency' (1879); 'Lindley on Partnership' (1881); and written 'Leading Cases in Disabilities' (1876); 'Treatise on the Law of Fixtures' (1877); 'Student's Manual of Medical Jurisprudence' (1887; 2d ed., 1909); 'Essentials of Law' (1882; 2d ed., 1915).

**EWELL, Richard Stoddert**, American soldier: b. Georgetown, D. C., 8 Feb. 1817; d. Springfield, Tenn., 25 Jan. 1872. He was graduated at the United States Military Academy in 1840, and served during the Mexican War with Scott from Vera Cruz to the City of Mexico. At the outbreak of the Civil War he resigned his commission in the National army; joined the Confederates; was actively engaged throughout the war and attained the rank of lieutenant-general. He was at the battles of the first and second Manassas, where he lost a leg, Front Royal, Cross Keys, Port Republic and Cedar Mountain; and was later placed in command of the Second Corps of General Lee's army, upon the death of "Stonewall" Jackson. In this capacity he was in personal command and led the charges of the corps at the capture of Winchester, at Gettysburg, the Wilderness, and Spottsylvania Court House, but was transferred to the Department of Richmond after these engagements, owing to his inability, on account of his wounds, to withstand the hardships of another campaign. He was later captured by Sheridan at Sailor's Creek

with his forces (6 April 1865). After the war he retired to private life.

**EWER**, ū'ér, Ferdinand Cartwright, American Episcopal clergyman: b. Nantucket, Mass., 22 May 1826; d. Montreal, Canada, 10 Oct. 1883. He was graduated at Harvard 1848. After several years devoted to journalism he entered the Episcopal ministry and became rector of Grace Church, San Francisco, 1858. In 1862 he was chosen rector of Christ Church, New York, but his belief in the doctrine of the Real Presence and his introduction of ceremonies and practices not usual in Episcopal churches caused him to be charged with Romanism and he resigned. The majority of his communicants followed him to the parish of Saint Ignatius, New York, which was organized for him, and of which he continued rector till his death. He was an able controversialist, and wrote 'Two Eventful Nights, or the Fallacies of Spiritualism Exposed' (1856); 'Sermons on the Failure of Protestantism' (1869); 'Catholicity in its Relations to Protestantism and Romanism' (1878); 'The Operation of the Holy Spirit' (1880); 'Grammar of Theology' (1880).

**EWING**, ū'ing, Finis, American clergyman: b. Bedford County, Va., 1773; d. 1841. He received his license to preach in the Cumberland presbytery in 1802 and for many years was a successful revivalist. In 1810, with two others, he formed the presbytery which later became the Cumberland Presbyterian Church. In 1820-36 he held a pastorate at New Lebanon, Mo., and after 1836 at Lexington, Mo. He published 'Lectures on Important Subjects in Divinity' (1824). Consult Cossitt, 'Life and Times of Finis Ewing' (Nashville 1853).

**EWING**, Hugh Boyle, American soldier: b. Lancaster, Ohio, 31 Oct. 1826; d. there, 30 June 1905. He was educated at the United States Military Academy; in 1849 went to California in charge of an expedition sent out by his father, then Secretary of the Interior, to rescue emigrants from the snow-bound Sierras, whence he returned in 1852; practised law in Saint Louis 1854-56 and in Leavenworth, Kan., 1856-58. He served through the Civil War, becoming a brevet major-general; was United States Minister to The Hague 1866-70, and wrote 'A Castle in the Air' (1887); 'The Black List' (1893), etc.

**EWING**, James, American pathologist: b. Pittsburgh, Pa., 1866. In 1888 he was graduated at Amherst College and three years later at the College of Physicians and Surgeons of Columbia University. He also studied at Vienna and after his return was successively tutor, Fellow and instructor at Columbia from 1893 to 1899. In the latter year he was appointed professor of pathology at Cornell. He is an ex-president of the Association for Cancer Research and of the Harvey Society. His publications include 'Clinical Pathology of Blood' (2d ed., 1903); and articles in 'Textbook of Legal Medicine and Toxicology' (1903).

**EWING**, SIR (James) Alfred, Scottish physicist and engineer: b. Dundee, 27 March 1855. He was educated at the Dundee high school and the University of Edinburgh. For several years he was engaged in engineering work and was assistant to Lord Kelvin and

Prof. Fleeming Jenkin. He was professor of mechanical engineering at the Imperial University of Tokio 1878-83. While in Japan he devoted himself assiduously to the study of earthquakes, devising seismographs to record the earth's vibrations during such disturbances. In 1883 he became professor of engineering at University College, Dundee, and from 1890 to 1903 he was professor of mechanism and applied mechanics in the University of Cambridge. From 1903 to 1906 he was a member of the Explosives Commission and a member of the Ordnance Research Board 1906-08. In 1907 he was made C.B., and K.C.B. in 1911. In 1916 he became principal of the University of Edinburgh. He was awarded the royal medal for researches in magnetism in 1895. He has published many papers on scientific subjects, especially on magnetism and the physics of metals, in 'Transactions of the Royal Society' and elsewhere; also 'Treatise on Earthquake Measurement' (1883); 'Magnetic Induction in Iron and Other Metals' (1891); 'The Steam Engine and Other Heat Engines' (1894); 'The Strength of Materials' (1899); 'The Mechanical Production of Cold' (1908).

**EWING**, John, American Presbyterian minister and mathematician: b. Nottingham, Md., 22 June 1732; d. Philadelphia, Pa., 8 Sept. 1802. As a youth he exhibited marked ability in mathematics and later took a course of study in Princeton College. Upon graduating in 1755 he was appointed instructor in the college. He then became interested in theology and after finishing his course in divinity was licensed to preach by the presbytery of Newcastle, Del. In 1758 he received his appointment as instructor of the philosophical department in the College of Philadelphia and in 1759 became pastor of the First Presbyterian Church in that city, remaining such until 1773 when he was sent to England to solicit pecuniary aid in the establishment of an academy. In 1775 he returned to his native land, and in 1779, when the College of Philadelphia was changed to the University of Pennsylvania, he was placed in the station of provost, and officiated in that capacity until his death. He was also selected to serve on more than one boundary commission. His 'Lectures on Natural Philosophy' (2 vols., 1809), and a collection of sermons were published after his death.

**EWING**, Juliana Horatia Gatty, English writer for young people: b. Ecclesfield, Yorkshire, 3 Aug. 1841; d. Bath, Somerset, 13 May 1885. She contributed largely to a magazine started by her mother (Mrs. Gatty). On her mother's death the magazine was edited by her and her sister conjointly, and many of her best stories first appeared in it. Of her delightful tales of child-life we may mention 'Mrs. Over-the-Way's Remembrances' (1869); 'The Land of Lost Toys' (1869); 'The Brownies' (1870); 'A Flat-iron for a Farthing' (1873); 'Lob-lie-by-the-Fire' (1874); 'Six to Sixteen'; 'Jan of the Windmill' (1876); 'A Great Emergency' (1877); 'We and the World' (1881); 'Old Fashioned Fairy Tales'; 'Brothers of Pity' (1882); 'The Doll's Wash'; 'Three Little Nest Birds'; 'A Week Spent in a Glass House'; 'A Sweet Little Dear'; and 'Blue Red' (1883); and 'Jackanapes' (1884). A biography by her sister, Horatia K. T. Gatty, was published in

1885 under the title 'Juliana Horatia Ewing and Her Books.'

**EWING, Thomas**, American statesman: b. near West Liberty, Va., 28 Dec. 1789; d. Lancaster, Ohio, 26 Oct. 1871. He was graduated at the Ohio University in Athens in 1815; admitted to the bar in 1816; and practised law for 15 years. He was a United States senator from Ohio 1831-37 and 1850-51; Secretary of the Treasury under President Harrison in 1841; and Secretary of the Interior under President Taylor in 1849-50. In the United States Supreme Court he ranked among the foremost lawyers of the nation. During the Civil War his judgment in matters of state was frequently sought by President Lincoln. When the capture of Mason and Slidell brought England and the United States to the very point of hostilities, Ewing sent the famous telegram that was really decisive of the whole trouble: "There can be no contraband of war between neutral ports" — and it was his advice that finally prevailed over Everett's opinion, and the envoys were set free.

**EX CATHEDRA** (Lat. "from out the chair"): a phrase originally applied to decisions given by the Pope in the discharge of his spiritual office as pastor and bishop of all Christians. Hence it is applied to every decision pronounced by any one in the exercise of his proper authority, as a bishop in the spiritual sphere, a judge on the bench, etc.

**EX PARTE**, ěks par'tē (Lat. "from a part"), a law Latin term used in reference to an action taken by either party to a suit or other legal proceeding, or on behalf of such party, without notice to the other. *Ex parte* evidence or hearings are frequently made use of without being regarded as an infringement of the rights of the opponent. In a derived sense the term indicates a lack of accuracy or impartiality in a statement.

**EX POST FACTO** (eks pōst fāk tō) **LAW** (Lat. "from what is done afterward"), one made after an offense and taking effect retroactively. The provision in the Constitution of the United States, Art. I, sec. 9, clause 3, that "no . . . ex post facto law shall be passed," has been interpreted to refer only to crimes, and in that sense the words are commonly used. The following have been decided to come within the scope of the phrase: Every law that makes an action done before its passage, and innocent when done, criminal, and punishes such action; every law that aggravates a crime, or makes it greater than when committed; every law that changes the nature of the punishment, or makes it greater than at the time the act was committed; every law that alters the rules of evidence so as to make it easier to convict the offenders; every law that, while not avowedly relating to crimes, in effect imposes a penalty or the deprivation of a right; every law that deprives persons accused of crime of some lawful protection to which they have become entitled, as a former acquittal. Such laws are therefore contrary to the Constitution. Consult Cooley, 'General Principles of Constitutional Law in the United States' (3d ed., 1900).

**EXACTIONS** (from Lat. *exactio*, act of driving out, forcing out, a forced contribution),

a legal term of ecclesiastical jurisprudence, used in the Middle Ages to denote such duties or contributions, demanded by the clergy of their parishioners, as were extraordinary, either because they were new and against custom or because their amount was unduly increased. They were illicit, and it was found necessary repeatedly to denounce their unlawfulness. The power of the clergy over their parishioners or of the bishops over the subordinate clergy was so great that it was easy for them to make the most outrageous exactions. They were denounced at the third Council of Toledo (589).

**EXAMINERS, Medical**, in some States, as Massachusetts and New York, county officials whose duties are practically those formerly discharged by coroners, whom they have superseded. See **CORONER**.

**EXANTHEMATA**, ěk-sān-thē'ma-ta, a name formerly widely employed to designate the acute infectious diseases that were characterized by an eruption — the eruptive fevers. The most important of these are measles, scarlet fever, chickenpox, smallpox, typhoid fever, and typhus fever (qq.v.). The term is also used in botany for blotches and eruptive excrescences on the surface of leaves.

**EXARCH**, ěks'ark (Gr. *εξάρχος*, *exarchos*, leader), a title equivalent to governor (Lat. *rector*), in the terminology of civil government after the seat of empire was transferred to Constantinople. But already in the 4th century it acquired the signification of archbishop, metropolitan or patriarch. In the acts of the first Council of Constantinople (381) the bishops of Alexandria, Antioch and Constantinople are styled exarchs; and the field of jurisdiction of an exarchos is exarchia. In the same period exarchos, exarchia were in use as designations of civil magistrates and their jurisdictions, the terms diocese (*διοίκησις*, *diocesis*) was also used. In ecclesiastical usage exarch came in time to be a title of honor apart from jurisdiction; thus, by the Council of Chalcedon (451) the bishops of Ephesus, Heraclea and Cappadocian Cæsarea, though deprived of their jurisdiction over the metropolitans previously suffragan to them, were permitted to be called by the title exarch.

**EXAUVILLIEZ, Philippe Irénée Boistel** d, fē-lēp ē-rē-nā bwās-tēl děks-ō-vē-ē-ā, French author: b. Amiens, 6 Dec. 1786; d. Paris, 30 March 1862. His essay, 'The Saint Gervais Library' (1831), gave the first impulse to the establishment of small libraries all over France. He translated Walter Scott's novels, from which he eliminated every passage which could be interpreted as telling against the Roman Catholic religion, and also all love passages as far as possible.

**EXCALIBUR**, the famous mystic sword of King Arthur (q.v.) which, in accordance with the promise of Merlin, was given him by the Lady of the Lake. At Arthur's death it was hurled by Sir Bedivere into the lake, where it was seized and conveyed from sight by a mysterious hand. Consult Tennyson, 'Idylls of the King.'

**EXCAVATION**, the removal of material in engineering operations in order to make space for some structural work. There is a wide variety of such work and the special proc-

esses are described under CANALS, DAMS, FOUNDATION, TUNNELS, etc.

**EXCAVATOR**, a machine for digging, moving and transporting gravel, soil, etc. Excavators are made of two kinds, each adapted for different kinds of work. In making a long cutting, the first to come into operation is operated on rails, and employs a large "scoop" or bucket, with a lever heavy enough to counter-balance the bucket when filled with clay. The scoop is lowered and driven into the bank until full. It is then raised by the suspension chain, and dumped by the chain on the lever. The second class of excavator is employed to make the cutting wider. Its sides are made sloping to an angle of 45 degrees, and on the top of the bank a temporary line of rails is laid a few feet from the edge. The machine is placed on the rails at the end of the cutting; the jib is lowered until the row of buckets it carries can cut into the clay; these scrape up the bank, reaching the top of it full of soil; they next pass over the machine, and are emptied into the wagons beyond it. Excavators were extensively employed in the digging of trenches and construction of breastworks on the Western front during the Great War. Consult McDaniel, 'Excavating Machinery' (New York 1913).

**EXCELLENCY** (from Lat. *excellētia*, superiority), a title of honor given to ambassadors, ministers plenipotentiary, governors of British colonies and their wives and the governor of Massachusetts. The President of the United States and the governors of many of the States have the same title by courtesy. In former times it was applied only to sovereign princes.

**EXCELMANS**, ěk-sěl-măn, or **EXELMANS**, Rémi Joseph Isidore, rā-mě zhō'zěf ě-sě-dōr, BARON, French marshal: b. Bar-le-duc, 13 Nov. 1775; d. 10 July 1852. He entered the army in 1791, served with distinction at Austerlitz in 1805, and gained the rank of general of brigade for his conduct at Eylau in 1807. In the Russian campaign (1812) he commanded a division. He directed a corps at the battle of Waterloo, after which he passed four years in exile; was restored to his title as a peer in 1831, and became a marshal of France in 1851.

**EXCELSIOR** (Lat. "higher") (1) the motto of New York State. (2) A well-known poem by H. W. Longfellow, published in 1841, of which the opening words are: "The shades of night were falling fast." The poem in its musical setting became in America a favorite academic song.

**EXCELSIOR**, the trade name of a material invented in America and widely used for packing and as stuffing in mattresses and upholstery. It is made from logs of wood which have first been divided into 18 inch blocks. The fibres are separated from the blocks with great rapidity by knife-points, and packed in bales of 250 pounds weight. Not far from 140,000 tons are annually manufactured in the United States, and of this output large quantities are exported.

**EXCELSIOR SPRINGS**, Mo., city of Clay County, 25 miles northeast of Kansas City, on the Chicago, Milwaukee and Saint Paul, the Wabash and other railroads. Because of its mineral springs it is widely known as a summer

resort; it has fine hotels, a Carnegie library, an auditorium, a government building and several pavilions. Its industrial establishments are limited to bottling works and an ice factory. Pop. 3,900.

**EXCEPTION**, an objection taken to testimony or any relevant matter in a legal proceeding, also to an adverse ruling of the court upon a point of law. In general, it must be taken within a prescribed period and must be entered on the record. The term is also given to the exclusion of some part of an instrument, or statement. It may mean also the part so excluded. See PLEA AND PLEADING.

**EXCESS**. In spherical and Riemannian non-Euclidean geometry, the excess of a triangle is the amount by which the sum of its angles exceeds 180°. Thus the spherical excess of a spherical triangle with angles of 70°, 60° and 65° is 15°. Similarly, the excess of a polygon is the amount by which the sum of its angles exceeds the sum of the angles of a plane Euclidean polygon with the same number of sides. The spherical excess of a triangle or polygon, if measured in radian, is equal to the area of the figure divided by the square of the radius of the sphere. In Lobachevskian geometry the defect, or the amount by which the sum of the angles of a polygon falls short of that of a plane Euclidean polygon with the same number of sides, plays a part quite analogous to that of spherical excess. The term excess is also used to indicate the remainder when one number is divided by another. See TRIGONOMETRY.

**EXCHANGE**, the act of exchanging or giving one thing for another. The term also signifies that which is so given. In commerce it is applied to a place where merchants, brokers, etc., meet to transact business; it is generally contracted into 'Change. The institution of the modern exchange dates from the 16th century. Those institutions originated in the important trading cities of Italy, Germany and the Netherlands, from which last-named country they were introduced into England. The most celebrated are the Royal Exchange of London, the *Bourses* of Paris and Amsterdam, the Bourse of Hamburg and the New York Stock Exchange in Wall street. In some exchanges only a special class of business is transacted. Thus there are stock exchanges, corn exchanges, coal exchanges, cotton exchanges, etc. For Bill of Exchange, see BILL.

*Course of exchange* is the current price of a bill of exchange at any one place as compared with what it is at another. If for \$500 at one place exactly \$500 at the other must be paid, then the course of exchange between the two places is at par; if more must be paid at the second place, then it is above par at the other; if less, it is below it. *Arbitration of exchange* signifies the operation of converting the currency of any country into that of a second one by means of other currencies intervening between the two. Consult Goschen's standard work, 'The Theory of Foreign Exchange'; and Withers, 'Money Changing' (1913).

In arithmetic *exchange* is a rule for ascertaining how much of the money of one country is equivalent in value to a given amount of that of another. In law, a mutual grant of equal interests, in consideration the one for the other,



is termed *exchange*. In physics the *theory of exchange* is a hypothesis with regard to radiant heat, devised by Prevost of Geneva, and since generally accepted. All bodies radiate heat. If two of different temperatures be placed near each other, each will radiate heat to the other, but the one higher in temperature will receive less than it emits. Finally, both will be of the same temperature, each receiving from the other precisely as much heat as it sends it in return. This scale is called the mobile equilibrium of temperature.

**EXCHANGES, Government Regulation of.** This regulation in no way differs from that controlling other associations, corporations or banking institutions, exchanges having no different or special relations with governments. They may be held liable for restraint of trade if they fix prices; their transactions may be subject to special taxes, or they may be considered as gambling under some circumstances. See STOCKS and STOCK EXCHANGE.

**EXCHEQUER**, ěks-chĕk'ĕr, in Great Britain, the department which deals with the moneys received and paid on behalf of the public services of the country. The public revenues are paid into the Bank of England, or the Bank of Ireland, to account of the Exchequer, and these receipts as well as the necessary payments for the public service are under the supervision of an important official called the controller and auditor-general. The public accounts are also audited in his department.

**EXCHEQUER, Chancellor of the.** See CHANCELLOR.

**EXCHEQUER, Court of.** See COURT.

**EXCHEQUER BILLS**, bills of credit issued by authority of the British Parliament as a means of raising money for temporary purposes. They are of various sums and bear daily interest. Generally paid off, or renewed annually they were much in demand and usually quoted at a premium, and were receivable in payment of taxes. These bills pass from hand to hand as money, and form a principal part of the public unfunded debt of Great Britain. Exchequer bonds, which have generally superseded them in recent years, are similar, but they run for a definite number of years at a fixed rate of interest. Exchequer bills somewhat resemble the treasury notes which were adopted as a financial expedient in the United States before the Civil War.

**EXCHEQUER TALLIES**, seasoned wands of ash, hazel or willow, formerly used for checking accounts in the English Exchequer. Notches cut on the tally indicated by their form the class to which the account belonged.

**EXCIPIENT** (from Lat. *exipere*, take up, undertake), in pharmacy, an inert or slightly active substance used to give form and consistence to solid preparations, such as pills, or to give palatability and the necessary qualities for administration to any medicine. The various conserves, also honey, treacle, simple syrups, glycerin, white of egg and mucilage of acacia are among the most useful excipients.

**EXCISE**, an inland duty or impost laid on commodities produced and consumed in the country. The word seems to be derived from a Dutch term of similar meaning, which in turn may be of same origin as *assise*, its present

form being influenced by a supposed derivation from Latin *excisus*. It must be differentiated from customs duty, imposed on goods entering a country. In England excise duties were established in 1643. On one article, spirits, the duty was at first only a few pence per proof gallon; in 1915 it was 14s. 9d. In the United States the internal revenue duties are analogous to the British excise. For a more detailed explanation of excise, see CUSTOMS; INTERNAL REVENUE.

**EXCISE LAWS IN THE UNITED STATES.** The struggle of the English people against excise was not due to any intrinsic iniquity in the tax, but partly to popular dislike of all direct taxes (see CUSTOMS; TARIFF); partly to the inquisitorial methods involved, partly to their use as a means of strengthening the royal power against popular control. At any rate, the colonists inherited this unreasoned dislike, even under totally different conditions; though Connecticut had laid an excise on spirits and all use of foreign articles, and Massachusetts and Pennsylvania on spirits, before the Revolution. But all shrank from giving the national government such power, and several States proposed amendments to the Constitution forbidding the United States ever to lay excises. Hamilton, however, recommended to Congress in 1790 an excise on spirits, upon the most advanced modern grounds — that it would not only produce a revenue without burdening any worthy industry or person, but would check the consumption, to the great advantage of the community. With great opposition the law was passed, imposing a duty of 9 to 25 cents a gallon (according to strength) on all native spirits, and a higher one on imported. In 1792 the tax was lowered somewhat. Later, under Hamilton's advisement, the scope was extended to other articles of luxury, auction sales, stamp duties on instruments of exchange, etc. But it was nullified in some sections by passive resistance; at last in 1794 a furious open defiance began in Pennsylvania (see WHISKY INSURRECTION), which had to be quelled by the regular army. There was no further resistance, but no cessation of the dislike, which was naturally a Democratic tenet, from the power it gave the general government; and when Jefferson became President, on his recommendation Congress abolished the entire system, which was possible from the large increase in customs receipts. The War of 1812, however, necessitated a fresh resort to it; and duties were laid on spirits (license tax), and the same articles Hamilton had chosen — sugar, carriages, auctions and exchanges — with salt added. They were repealed in December 1817, and no further excises were levied till the system of internal revenue taxes (q.v.) was adopted in 1862.

**EXCITANT.** See STIMULANT.

**EXCITO-MOTOR ACTION**, the action of nerves distributed to muscular organs the stimulation of which leads to movement. Thus, irritation of a nerve supplying a muscle will lead to contraction of the muscle by excito-motor action, and irritation of certain nerves distributed to blood vessels will lead to contraction of the vessel by acting on its muscular coat. See NERVOUS SYSTEM.

**EXCLUSION**, Bill of, a bill introduced into the British Parliament (1679) during the

reign of Charles II for the purpose of excluding the Duke of York, he being a Roman Catholic, from the throne. See CHARLES II; JAMES II.

**EXCOMMUNICATION**, an act of ecclesiastical jurisdiction whereby a Christian is separated from the communion of the Church. It is not, however, peculiar to biblical religion, a discipline somewhat analogous being exercised by the ancient Romans. The clearest analogy to the Christian discipline is that furnished by the rabbinical code, whereby offenders were excluded from civil and religious fellowship. Under the Christian dispensation this power was exercised by the Apostle Paul when in his first letter to the Corinthians, ch. v, he writes concerning a man guilty of incest that he "delivers such a one to Satan." Authority for excommunication is found in the words of Christ reported in Matt. xviii. "If he will not hear the church let him be to thee as the gentile and the publican." In the Roman Catholic Church there are two degrees of excommunication—major and minor. By the minor an offender is deprived of the use of the sacraments; by the major one he is deprived of all manner of communion or communication with the faithful. In the times when the laws of the Church were enforced in their primitive rigor the excommunicated were denied communication with the faithful not only in sacred things but in the common life; and if a monarch, his subjects were absolved from all allegiance. This is greatly modified now, and persons who have incurred the uttermost ecclesiastical censures suffer only the spiritual penalties attached to their offenses. But though the Church's excommunication has in the present time lost all its civil effects, a brief notice of these effects is necessary for an appreciation of the condition of an *excommunicatus vitandus*, that is, of a person under the major excommunication, who must be avoided by the faithful, under penalty of themselves incurring the minor excommunication.

A person who is under the major excommunication is disqualified for acting as judge or juror, notary, witness in courts of law, advocate, attorney; but he is competent to plead his own cause and to sue others on his own behalf. He cannot be a guardian of a minor, nor curator, nor executor of a last will, nor can he make contracts. He cannot act as a legislator. After death his body is deprived of Christian burial; and if it does get burial in consecrated ground in whatever way, it is to be dug up and cast out. The excommunicate under major excommunication must be shunned by all the faithful; they must not, under pain of excommunication (minor), communicate with him either by word of mouth or by writing; must not greet him, nor have exchange of gifts with him. If an *excommunicatus vitandus* happens to enter a church while the Mass is proceeding, he must forthwith be put out; if that cannot be, then the service must be suspended. Such is the letter of the laws; but long before these stern prescriptions went into desuetude there were notable assuagements of their rigor through the interpretations of moralists. To illustrate this by one example only: The serfs and servants and the children, grandchildren and other relatives (even by affinity only) were

permitted to continue their relations of obedience and respect to their head even after he was excommunicated. See BELL, BOOK AND CANDLE.

The Reformers claimed and exercised the same rights in regard to excommunication as did the Roman Church. In England the excommunicated person was subjected to various disabilities; he could not hold a benefice, or practise as a barrister or attorney in the courts; and could not be admitted as a witness. These were removed by Act of Parliament in England in 1813, and in Ireland in the following year. In the Presbyterian churches of Scotland the lesser excommunication involved deprivation of "sealing ordinances"; the greater excommunication is now unheard of, and since the Revolution of 1688 has carried no civil consequences with it.

**EXCRETION.** See FÆCES; SWEAT; URINE.

**EXCRETORY SYSTEM, Comparative Anatomy of the.** See ANATOMY.

**EXCURSION, The.** 'The Excursion' (1814), Wordsworth's longest poem, was originally designed as the second part of a still vaster work, 'The Recluse,' in which the poet intended to embody in monumental fashion his ripest reflections on man and nature. Of this enterprise 'The Prelude,' which was to have constituted an introduction, 'The Excursion,' in nine books, and one other fragment were completed. Less interesting, on the whole, than 'The Prelude' and the best of the shorter poems, 'The Excursion' is yet a rich and noble work of genius, not to be neglected by those who would master Wordsworth's philosophy or appreciate the full compass of his powers. The poem consists of a series of dialogues, of which the protagonist is The Wanderer, a venerable friend of the poet's, who from long and loving contact with nature and a deeply sympathetic knowledge of human life, has reached the heights of optimism and philosophic calm. Meeting the poet at a ruined hut on a common he tells in the first book the pathetic story of Margaret, its last inhabitant. They then pass to the secluded abode of The Solitary, a person in whom Wordsworth has embodied the disillusionment and despondency characteristic of the age, a reflection of what Wordsworth himself might have become after the French Revolution had not the malady been checked by a timely return to the tranquillizing influences of his early years. (See PRELUDE, THE). The conversation of The Wanderer and the subsequent discourses of a good Pastor, visited by the party in his parish, are directed toward a correction of The Solitary's despondency. Standing amid the graves of a country churchyard, The Pastor tells the simple but affecting stories of the lives of those who lie buried there. In Books VIII and IX The Wanderer discourses of society and government, deploring the industrial exploitation of the poor, advocating a system of universal education and exalting morality as the true basis of national greatness and the highest fruit of freedom. Despite some tediousness inseparable from the didactic character of the theme, the poem is a moving record of a mature and sobered idealism, firmly held in the face of all the influences which work against it—an impressive memorial

of the strength and comfort which Wordsworth found

In the primal sympathy  
Which having been must ever be;  
In the soothing thoughts which spring  
Out of human suffering;  
In the faith that looks through death,  
In years that bring the philosophic mind.

For reference, see article on 'THE PRELUDE.'  
JAMES H. HANFORD.

**EXE**, a river of England, rising in Somersetshire and flowing southeast to the Devonshire border, thence south through Devon and debouching into the Channel at Exmouth. Its length is about 54 miles. Tiverton and Exeter are situated on the banks of the Exe.

**EXECUTION**, in law, the carrying into effect of the final judgment, decree or order of the court. Execution is effected by a writ or order directed to the proper officer and commanding him to do a certain thing. In civil law it is the means of obtaining that which the court ordered to be done by one of the parties. Execution may be had for either plaintiff or defendant. When taken out by the plaintiff it depends on the cause of action as to what is to be recovered under the writ; generally it is for the debt and costs or for the goods, damages and costs. When taken out by the defendant it may be for goods, damages and costs, and in some cases it may be only for costs.

As soon as final judgment has been entered, the party entitled to it may take out his writ of execution, and he is entitled to this writ until the other party has taken some step which is a *supersedeas*, such as an appeal or writ of error. The writ issues from the court which last passed on the judgment on which the writ of execution is taken out. Execution may be against personal property, taking and selling it, or it may be against real estate, either holding it until the judgment is paid or selling it, or in some cases by the seizure of the person of the defendant and holding him until the judgment is satisfied or until he is declared insolvent. If the property is sold the fund derived from the sale is applied to paying the judgment and costs, and the surplus, if any, is returned to the former owner of the goods. At common law, however, real property was not subject to execution except for a debt due the State or the king. By statute of 5 George II, c. 5, real estate in the colonies became subject to sale under execution the same as personal property. A writ of execution, although issued at the instance of the party in whose favor the judgment is, must be directed to the sheriff, who must carry out the direction of the writ. If he fails to do so he must answer in damages to the injured party.

Originally, at common law, when the execution was against personal property, such as goods and chattels, the writ of *feri facias* was used, but to-day this writ may be used against land also. When the personal property consisted of choses in action it was reached by a writ of attachment. If the execution was against real estate a writ of *scire facias* was used (now usually *elegit* or *feri facias*), and it was sold under a writ of *venditioni exponas*. In some cases, when the judgment was confined to a particular piece of real estate, the writ of *levari facias* was issued first and it was sold under a writ of *venditioni exponas*. In modern

usage, if the execution is against the person of the defendant a writ of *capias ad satisfaciendum* may be issued in some jurisdictions, under which the defendant is arrested and his person held until the judgment is satisfied or until the defendant is declared insolvent. Sometimes the defendant is released if security is given that the defendant will abide by the order of the court. Nearly all these writs and other old forms are obsolete or modified in use except *feri facias* and, to a less extent, *elegit* and *capias ad satisfaciendum*. See ATTACHMENT; FIERI FACIAS; SCIRE FACIAS.

A general judgment binds all property owned by the person against whom the judgment is recovered at the time the judgment is entered, and it also attaches to all property he acquires up to the time the judgment is satisfied, and if the debtor sells any real estate before the judgment is satisfied, the property is not released from the lien of the judgment. When property is sold under an execution the purchaser buys only the title of the debtor, and all equities under which he held it still attach to the property.

In criminal law execution is the carrying into effect of the judgment of the court in relation to the person convicted. It consists in putting the convict to death according to his sentence. See CAPITAL PUNISHMENT.

**EXECUTION, Military**, in drill regulations, the command following the preparatory command and causing the execution of the latter. Legally, a military execution is the putting in effect the sentence of a military court. See MILITARY LAW.

**EXECUTIONER**, the official who carries into effect a sentence of death or inflicts capital punishment in pursuance of a legal warrant. In England it is the province of the sheriff to execute the extreme sentence of the law, but in practice the disagreeable duty is performed in his presence by an officer retained for this purpose. In Scotland the duty devolves upon the civic magistracy, but the strict letter of the law is avoided as in England by the attendance of a magistrate to witness the proceedings. Several executioners have become famous from their names being dragged into literature; such as Richard Brandon, the supposed headsman of Charles I; Jack Ketch, commemorated by Dryden (Epilogue to the Duke of Guise), whose name was long vulgarly given to all who succeeded him (in London) in this odious office. In America, the title and duties of the public executioner differ in the various States. In some States the sheriff of the county becomes the executioner, but in New York State the warden of the penitentiary is technically the executioner. The duties are usually performed by one of his subordinates. In the army the provost-marshal is the military executioner. See CAPITAL PUNISHMENT; ELECTROCUTION; GUILLOTINE; HANGING.

**EXECUTIVE**, in the United States, properly, though in the narrow and restricted sense, the entire official body charged with the execution of the laws, but popularly the chief officer, as President (of the United States), governor (of a State), mayor (of a city), etc.

**Executive Power**.—The executive functions in the modern state are much more diversified and important than the usual definition of the

word "executive" would indicate, since, besides enforcing the laws enacted by the legislative department of government, the executive, in the larger sense, must formulate and carry out constructive policies, direct the public life of the state, act as its representative in its relations with foreign states, render many highly-important decisions and exercise wide discretion and judgment. Hence the executive power covers a range of official activities wider and more significant than the mere fulfilment of the commands of the legislature. The organization of the legislative and executive branches of government necessarily must differ because the former is the body which deliberates upon the needs of the state and enacts the legislation required to meet such demands, while the latter's primary, though not its sole, function is to execute with the utmost promptness, energy and efficiency the will of the state as formulated by the legislative body. To attain such results a single executive is most desirable, since the division of executive power between several co-equal authorities would create confusion in times of stress, would enable the responsibility for action easily to be shifted from one shoulder to another, and would result in a lack of unity and efficiency in government so essential to its success. In ancient Athens executive power was divided between generals and archons; in Rome between two consuls, and in Sparta for many years between two kings, while in France between 1795 and 1800 a directory (q.v.) of five persons was in office and later three consuls held the executive power. The general executive of the American colonies was the king; their individual executives, the governors, appointed by the Crown or (in Rhode Island and Connecticut, and for a few years in Massachusetts) chosen by the people. These were succeeded *de facto* by the committees or councils of safety; then by officials usually called governor, sometimes president, and sometimes not by single persons, but by executive councils, as in Switzerland. (See also COLONIAL GOVERNMENTS, PROPRIETARY). The general government had no executive till the adoption of the Constitution (q.v.). The Continental Congress (q.v.) had only such functions as the State legislatures allowed it, which were to debate and ask for supplies and make recommendations; and the Articles of Confederation provided for no executive. (See UNITED STATES — THE ARTICLES OF CONFEDERATION). At the present time executive power is organized on the single person plan in all countries save Switzerland which has an executive council of seven members.

In general executive power may be said to include the execution of the laws and treaties; the conduct of foreign relations either with or without the aid or consent of the legislature or one of its branches; the command and disposition of the military and naval forces; the power to approve or disapprove acts of the legislature, to recommend subjects and measures for its consideration, and in some countries to summon, open and prorogue its sessions; the power of appointing and dismissing the more important administrative officials; and the right to pardon those who have offended against the laws, save in impeachment cases. The executive branch of the government

in nearly all states, in a greater or lesser degree, is empowered to issue ordinances, regulations or decrees establishing rules for the conduct of governmental officials and affairs, to interpret statutes for the guidance of officials and to supplement laws respecting numerous matters that have been left to the discretion of the executive. In England such executive legislation is accomplished by the "statutory rules and orders" issued by the departments of state, especially the home office and the local government board. In France the legislature enacts laws on broad, general principles and allows the executive to insert the details by means of ordinances. The undefined and now greatly restricted "royal prerogative" of the executive in monarchical states has no statutory authority and may be considered the remnant of the king's common-law powers. See the articles or paragraphs on "Government" under the titles of the various nations.

#### RELATIONS OF THE NATIONAL EXECUTIVE AND CONGRESS.

**Separation of Powers.**—When the Constitution was framed the belief prevailed that the executive, legislative and executive departments of government should be separate and independent, but nevertheless this separation was subject to some modifications in the Constitution as adopted and has been considerably changed by the practices which have developed since. The Senate was allowed to wield a certain amount of executive power in that it was entrusted with the confirming of appointments; Congress was given a considerable degree of control over the administration through its right to establish, regulate and maintain the various departments; and the President could participate in legislation through his right to address or send messages to Congress and through his power of veto. In recent years the contest for domination between the executive and legislative branches has resulted in a struggle in which each has endeavored to strengthen its own position at the other's expense.

**Patronage.**—Under Article II, § II, ¶ 2 of the Constitution the President has power, "by and with the advice and consent of the Senate, to make treaties, provided two-thirds of the Senators present concur; and he shall nominate, and by and with the advice and consent of the Senate, shall appoint ambassadors, other public ministers and consuls, judges of the Supreme Court, and all other officers of the United States, whose appointments are not herein otherwise provided for and which shall be established by law; but the Congress may by law vest the appointment of such inferior officers, as they think proper, in the President alone, in the courts of law, or in the heads of departments." Though the fathers of the Constitution probably intended that the Senate should refuse to confirm Presidential nominations because of unfitness only, the Senate has not hesitated to use its power in this respect for partisan purposes, chiefly to coerce the President. Under this senatorial power has arisen the practice known as "Senatorial courtesy" (q.v.), the extent and importance to which this practice may attain depending largely on the President's character and forcefulness. The Constitution makes no provision respecting removals from office, but in 1867, at

the time of the dispute between President Johnson and Secretary Stanton, Congress passed the Tenure-of-Office Act (q.v.), providing that persons appointed with the consent of the Senate should hold office until their successors were appointed in like manner; in other words, the incumbent could be removed only with the consent of the Senate. The doubtful legality of the act caused material alterations in 1869 and its final repeal in 1887. (See also DE FACTO GOVERNMENT). Impeachments are rarely used, though all branches of the government have had occasion to employ this cumbersome procedure (President Johnson, Judges Pickering, Chase, Humphreys, Peck, Swayne and Archibald; Senator Blount; Secretary Belknap) and in the nine cases only three convictions have resulted (Pickering, Humphreys and Archibald), while Blount and Belknap were out of office when their cases came up for consideration. Save by the method of impeachment Congress cannot remove objectionable officials, though it may investigate and discredit them and thus compel their resignation or dismissal. See APPOINTMENTS; UNITED STATES—THE NEW DEMOCRACY AND THE SPOILS SYSTEM; UNITED STATES—IMPEACHMENTS.

**Treaty-Making.**—The legislature is seldom allowed to participate in the negotiations of treaties, but to exclude errors and to prevent the possibility of abuse by an unwise, ambitious or unscrupulous executive, the legislature, or one branch thereof, usually possesses power of ratification before treaties negotiated by the executive may become the law of the land; hence the treaty-making power is neither purely executive nor legislative in character. The Senate practically controls the power of making treaties through the constitutional provision, as previously stated, that two-thirds of the Senators must approve the treaty; as a result of the encroachment of the legislature on the executive the Senate now to a certain degree participates in the negotiations through its committee on foreign relations. The House has often endeavored to exert some influence over the course of negotiations but the President is not obliged to heed the advice of the House, its concurrence being necessary only when legislation is required to render treaties effective. Sometimes, to circumvent the certain defeat of a treaty in the Senate, the President has entered into an "executive agreement" with the country involved, under which, by independent action, the chief provisions of the proposed treaty were carried out. See TREATIES.

**Departmental Affairs.**—The President's power and influence over the executive departments vary and in many respects are subject to Congressional limitation. He is the head of the National administration, is obliged to enforce the faithful execution of all laws, and under Article II, § II, ¶ 1 of the Constitution "may require the opinion, in writing, of the principal officer in each of the executive departments, upon any subject relating to the duties of their respective offices"; yet the departments, being organized by Congress, are subject to the will of Congress under statutory regulation, which situation somewhat curbs Presidential power over departmental heads and their subordinates. From a strictly legal standpoint, the President does not possess full authority in respect to the control and direction of adminis-

trative affairs but he can establish himself as the chief executive and administrative officer of the government and can make his will effective by removing an officer who refuses to comply with his wishes and appoint one who will do so—as was the case when President Jackson compelled the removal of government funds from the United States Bank. However potent this power may be, it could not be said to constitute the President's chief means of control over administrative affairs since his authority has been strengthened constantly by an ever-broadening construction of the constitutional provisions requiring him to execute the laws. His power to issue and enforce executive orders pertaining to administrative affairs has been sustained by numerous opinions and the courts seldom interfere to upset firmly established precedents. When clothing the President with executive power the framers of the Constitution primarily intended that, besides enforcing the laws, he should perform acts of a political nature, such as conducting foreign affairs, which are not subject to judicial review. Hence Congress seldom hampers the President in his conduct of foreign affairs through the State Department, and the extent of his personal supervision of such affairs depends largely upon the personality (and of course the capabilities) of the Secretary of State. But in respect to vesting authority for the administration of affairs (other than political), the intent of the framers was not clearly indicated in the Constitution, since one or more of the secretaries is required to report annually direct to Congress instead of to the President; furthermore, when it deems necessary or wise, Congress may provide for the management of certain services by joint committees of the two Houses, and may authorize subordinate officials to perform certain acts without the consent, approval or intervention of their superiors or the President. (Among the administrative services outside the jurisdiction of the executive departments are the Interstate Commerce Commission, the Civil Service Commission, the Government Printing Office, the Commission of Fine Arts, the Smithsonian Institution, etc.). Congress maintains a close control and regulation over the Treasury Department and the administration of the financial needs of all departments. Although each secretary annually submits an estimate of his department's needs, Congress not only disregards the secretary's recommendations but, if in the mood, appropriates vast sums which are not only not requested, but which are deemed by the secretaries and the President to be unnecessary and wasteful. Such oftentimes are appropriations for rivers and harbors and public buildings, popularly known as the "pork barrel." See BUDGET SYSTEM, AMERICAN.

The executive endeavors to cultivate harmonious relations with Congress by complying with requests for opinions and advice, information, documents, etc., partly because the success of the administration's legislative program depends upon such harmony and partly because Congress controls the purse of the nation. This has resulted in bringing the executive and legislature together by devious and extra-legal methods, but in one instance an opposite development has occurred. In our early history Cabinet members sometimes appeared in person before Congress to give information or to

outline and advocate or oppose policies and this was not unconstitutional. Department heads cannot be members of either House though they are not excluded from the sessions, but the early practice was discontinued and seems unlikely to be revived, though this course was advocated by a Senate committee in 1881 and by President Taft in a message 19 Dec. 1912. See UNITED STATES — THE PRESIDENT'S OFFICE; UNITED STATES — THE CABINET OF THE; UNITED STATES — BEGINNINGS OF EXECUTIVE DEPARTMENTS OF THE; CABINET AND CABINET GOVERNMENT; CONGRESS; FEDERAL GOVERNMENT; CONSTITUTIONAL GOVERNMENT; and the various departments by name.

**Presidential Influence over Legislation.**— Under Article I, § VII, ¶ 2 of the Constitution the President may veto an act of Congress and such act cannot become law unless repassed by a two-thirds vote of both Houses. (See VETO; ACTS OF CONGRESS; BILLS, COURSE OF). This fact is important not because of the frequency of Presidential vetoes, but because it enables the President to dominate Congress in a large measure; by a threat to wield this weapon he may prevent the passage of bad laws and compel the elimination of objectionable features from otherwise good ones. Article II, § III provides that the President "shall from time to time give to the Congress information of the state of the Union, and recommend to their consideration such measures as he shall judge necessary and expedient." No method of communicating with Congress is suggested or prescribed and both the written message and the speech in person have been employed. Congress is not compelled to act upon the President's recommendations and seldom does complete the suggested legislative program, but as the legislation advocated by the President presumably coincides with the policy of the party by which he has been elected, as the majority of the members of Congress usually have the same political affiliations, and as the outcome of future elections is much influenced by the character of the legislation and the manner of its execution, the President's recommendations rarely are refused serious consideration and generally are enacted into law. Moreover Congress can ill afford to ignore public opinion and if the President be a capable party leader and can arouse public interest sufficiently to constitute a public demand he is quite sure to obtain the desired results. In recent years the President's influence has depended largely upon his ability to control his party whether through force or persuasion.

#### RELATIONS OF THE NATIONAL EXECUTIVE AND THE JUDICIARY.

Conflicts often arise in the relations of the executive and judiciary, due chiefly to the adoption of the doctrine of separation of powers and the fact that unconstitutional actions and laws are referred to the courts for determination. This conflict of relations is most noted as regards the State executives and the Federal courts. Amendment XI of the Constitution provides that "the judicial power of the United States shall not be construed to extend to any suit in law or equity, commenced or prosecuted against one of the United States by citizens of another State, or by citizens or subjects of any foreign State." Nevertheless the

courts have decided that this amendment does not apply to an injunction or mandamus suit brought against a State officer under a Federal statute or constitutional provision (*Ex parte Young*, 209 U. S. 123). On the other hand suits against Federal officers in the State courts have been rare and never successful (see, for instance, *Ableman vs. Booth*, 21 Howard 506; *Tarble's Case*, 13 Wallace 397). Conversely, in 1793 Congress passed an act prohibiting Federal courts to issue writs of injunction in order to stay proceedings in State courts, save in matters of bankruptcy ('Rev. Stat.' 720). Broadly speaking, the executive is not subject to judicial control in cases of discretion nor in any political matter, save that any executive order which is unconstitutional is null and void, even though it be issued by the President himself; and any officer or other person executing such unconstitutional order is liable in damages (*Little vs. Barreme*, 2 Cranch 170). In the case of *Marbury vs. Madison* (consult also Cranch 137) Chief Justice Marshall enunciated the doctrine that although the court could not interfere with the prerogatives of the executive it could and would command a head of a department to perform a duty not dependent on executive discretion; but the question of such executive coercion has not been extended to the President. Furthermore, so far as the President and Secretary of War are concerned, the court has decided that purely political actions by an executive are not subject to judicial review or injunction (4 Wall. 475; 6 Wall. 50). But while unauthorized and unconstitutional executive orders are null and void and private parties have the right to sue for damages those executing such orders, the mere allegation of unconstitutionality is not sufficient ground for the courts to enjoin the enforcement of a statute by the executive. In *Wilson vs. Shaw* (204 U. S. 24) Justice Brewer expressed the opinion, since Congress had ratified the executive action, that the courts "have no supervising control over the political branch of the government in its action within the limits of the Constitution." Indirectly through the appointing power the executive has considerable influence over the judiciary. See UNITED STATES — JUDICIARY OF THE; SUPREME COURT; COURT.

#### POWERS AND INFLUENCES OF THE STATE EXECUTIVE.

**Organization of the State Executive.**— Unlike the National Government, where the chief responsibility is concentrated in the hands of a single individual, the executive power and responsibility in the States are divided between the chief executive and a number of other State officers, virtually his colleagues, over whom he has little or no control, and who, save in rare instances, are elected by the people, to whom alone they are responsible. Sometimes the chief executive may belong to one political party and his subordinates or part of them to another, which renders difficult any co-operation among departments or between departments and the chief executive. Under early State constitutional provisions these State officers were either appointed by the governor or chosen by the legislature and thus the governor had a certain measure of control over the conduct of State business; but in late years these officers have been elected by

the people, as a result of which the governor no longer can be compared with the President as the head of the administration which has been placed in power, having no general authority to direct, remove or discipline such elective officers; his only power of supervision is the right to examine the administration of the respective offices and in some cases to remove the incumbents if found guilty of malfeasance, corruption or gross negligence. In a few States (New York for instance) the treasurer, if found to have violated his duty, may be suspended from office but not removed by the governor. As a rule the governor may remove his own appointees for good cause, but the person removed must be informed of the reasons and be afforded ample opportunity to refute the charges. In Massachusetts and a few other States the governor at first appointed all judges, sheriffs, court clerks, registers of probate and the attorney-general, but in most States all these officials (and in Massachusetts all save the judges) are elected by the people. In Maine a few of the department heads are appointed by the legislature, and in New Hampshire a few are elected on joint ballot of the general court. In Delaware and Texas the secretary of state is appointed by the governor, while in Maryland the secretary of state, state librarian and commission of law office, in New Jersey the secretary of state and the attorney-general, and in Pennsylvania the secretary of state, the attorney-general and the superintendent of public instruction are appointed by the respective governors with the advice and consent of the senate. In New Jersey the treasurer and in Tennessee the secretary of state are appointed by the general assemblies, but in the latter State the attorney-general is appointed by the judges. Governors still possess the pardoning power (in most States without restriction), but in a few New England States the pardon is incomplete without the concurrence of the executive council. The governor is commander-in-chief of the State military forces and may appoint his military staff, but as a rule the other militia officers are elected by the votes of the military organizations.

**Relation to Legislation.**—Like the President, the governor is authorized to convene the legislature in other than its regular sessions, and again like the President he presents for the consideration of that body his views respecting matters of public policy and importance and his recommendations of legislation to be enacted for the good of the State. As is the case with Congress the legislature is not obliged to heed his advice and often does not, but in many cases governors have made direct and effective appeals to the people to arouse public sentiment in favor of their plans. All the States save North Carolina empower their governors to veto legislative enactments with the exception of constitutional amendments, but when returning such rejected measures they must state their reasons for objection. Unless overruled by a two-thirds vote of both branches of the legislature the veto is absolute, but if re-passed by the necessary vote the enactment becomes law without the governor's signature; all other acts approved by him bear his signature.

**Administrative Powers.**—From the foregoing the governor's powers may be surmised as

lying not so much in his constitutional rights or privileges as in the moral atmosphere and prestige of his office, since he represents the highest dignity of the State. On all public occasions he is the first citizen of the State, the representative of its political, civil and military authority. As the official head of the State he sends and receives communications in its name; issues proclamations to its people; and owing to a variety of powers, including the bestowal of considerable patronage, his prominence in the public eye and his relation to the legislature, he has an influence in shaping legislation far exceeding a strict interpretation of his constitutional prerogatives. He is the official and natural exponent of the State in National affairs and in its relations to the Federal Government, for which reason he issues writs for the holding of elections to fill vacancies in Congress and even under Amendment XVII to the National Constitution may make temporary appointments of senators in case of vacancies until the people fill such vacancies by elections; he transmits ratifications of constitutional amendments and other acts of the State legislature which relate to National matters.

**Tendencies and Proposed Reforms.**—The evils of the subdivision of executive power have not only been recognized but in many States the tendency is to remedy such defects by strengthening the governor's control over the administration through a wider appointing power; by reducing the number of co-ordinate elective officials; by relieving him of the confirmation of his appointment, by the State senate; by recognizing his unrestricted removal power; by authorizing him to make special inquiries into the several executive departments and during the legislative recess to suspend officers who have violated the law; by empowering him to require from department heads written statements pertaining to anything connected with their respective duties; in some cases by allowing him, at stated intervals, to examine the accounts of officials such as the treasurer and auditor; and in some States by requiring the principal State officers to render to the governor periodic reports covering the activities of their departments, although such reports, even if convincing, as to the official's incompetency, neglect of duty or violation of the law, in no way augment the governor's power of supervision over the administration because of his greatly restricted power of removal. Although responsible for the faithful execution of the laws, the governor is often powerless, without the co-operation of the department heads, to carry out the constitutional injunction owing to the manner in which the executive power is divided; as an example, he cannot compel the attorney-general unwillingly to start a suit against an individual or a corporation chiefly because he has neither the power of direction or removal, and this same weakness characterizes his relations with other State officers. The enforcement of responsibility is impossible owing to the multiplication of departments exercising administrative powers, and this is particularly noticeable in States which have boards and commissions the members of which are often elected by the people, though even if they are appointed by the governor he has little power of control or supervision over the administration of affairs entrusted to them. New York, Pennsylvania

and Massachusetts each have nearly 100 such boards and commissions, but a movement is going forward to consolidate most of these boards into one board of control or board of affairs. The creation of the office of "state business manager," to organize and manage State business affairs under the governor's direction, has also been proposed. One governor has even recommended a system of State rule by commission, similar to the commission system of city government (q.v.). Another proposal is to authorize the governor to appoint the principal State officers, who, collectively, shall constitute a cabinet or council, and to give the governor a large power of initiating legislation. In this way the State executive would resemble the President and his Cabinet; thus the power and responsibility would be centralized, and unity, co-ordination and efficiency could be introduced into the administration of State affairs.

#### POWERS AND INFLUENCE OF THE MUNICIPAL EXECUTIVE.

**Growth of the Mayor's Powers.**—In the government of the borough during colonial times the executive and legislative functions were not separate. The council was the sole governing body and the presiding officer was called mayor. He was merely a member of the council, possessed no powers other than those of a presiding officer, could not veto enactments of the council and could make no appointments to office, though in a few boroughs he did have some minor responsibilities, such as regulating taverns, supervising markets, holding coroners' inquests and hearing petty contestations at law. After the Revolution and with the advent of the Federal Government, the mayor's powers were increased gradually but materially, owing to the influence of the separation of powers which was put in vogue in the National and State governments. For the first time in the history of American cities, Baltimore in 1796 empowered the mayor to veto resolutions of the city council, though vetoed measures might be re-passed by a three-fourths vote; the mayor's powers of appointment to city offices were also much enlarged. In 1822 Boston authorized the mayor to appoint whom he chose, subject to aldermanic approbation. But not until the middle of the 19th century did the municipal executive make much headway. The government of cities by council had developed inefficiency, waste, extravagance and considerable corruption, whereupon the State governments intervened, transferring various functions from the councils to State-appointed and controlled boards, as, for example, in 1860 the Baltimore police department was placed under the control of a State board; in 1866 the Chicago police suffered the same intervention; and in 1865 the New York legislature assumed control of police, fire protection, public health and licensing in New York city. Subsequently the legislatures restored a large measure of local control, but instead of reinstating the city council in power, they placed control in separate executive boards, the members of which were appointed by the mayor or elected by the people. Hence the power of appointment substantially increased the powers of the mayor's office and in time even the confirmation of the mayor's appointees by the al-

dermen was eliminated from city charters, as was the case in Brooklyn in 1882. Many other cities followed Brooklyn's lead and though a large number still retain the practice, it is gradually being abandoned. It should be remembered, however, that in no two cities of the United States are the mayor's powers alike, and in describing the position and powers of the American mayor even the most important statements must be made with large reservations; in New York and Boston the authority of the municipal councils is insignificant when compared with the powers of the mayors, whereas in Philadelphia and Chicago the reverse is true, the councils still maintaining a strong grip on local governmental affairs.

#### The Mayor's Influence upon Legislation.

—Theoretically the mayor's office is administrative and has no legislative power but often the mayor exerts a strong influence upon local legislation. In some cities, like Chicago, he presides over the sessions of the city council but in most cities he not only is deprived of this privilege but may communicate with that body only through a written message. Like the President and the State governor, the mayor may and often does suggest new legislation for the consideration of the council and to a certain degree the deference shown to his suggestions depends upon his personal character and political influence. Like the President, however, the mayor has an effective weapon in the veto power (but not the privilege of the "pocket veto"), since under most city charters he must pass upon every ordinance or resolution of the council, and in many cases mayors have used this privilege without scruple to enforce aldermanic submission. A prescribed majority must be obtained to override the mayor's veto whether the council consists of one or of two chambers, but though the usual practice is a two-thirds vote, the requirement is more rigid in some cities, being three-fifths in Philadelphia, three-fourths in Baltimore and seven-ninths in San Francisco.

**The Mayor's Appointing Power.**—In most cities the people elect a few heads of the city departments; in other cities some officers are appointed by the council; and in isolated cases important city officials may be appointed by the State executive or by the higher State courts. But in the majority of cities the mayor appoints the departmental heads, subject to the approval of the council or board of aldermen; sometimes, as in New York city, Denver and San Francisco, these appointments need not be confirmed by any municipal or State authority, but in a few cases, as in Boston, such appointments, to be effective, must be approved by a State civil service commission. Recently the system of council confirmation has been viewed with disfavor and the latest city charters omit the confirmation feature. See APPOINTMENTS, FEDERAL, STATE AND LOCAL.

**Miscellaneous Functions.**—As regards municipal finance, the mayor's powers have been largely increased; the preparation of the city budget, which formerly was under the supervision of the council, has been transferred to the city executive owing, in a large measure, to the inordinate amount of logrolling in which the councilmen indulge. In some cities, like New York, the preparation of the budget and the determining of the tax rate are supervised



by the board of estimate and apportionment and in other cities, like Boston, the mayor has direct charge of the work, but in all cases the city executive is deprived of the power of making appropriations, this being vested in the council, which, under certain restrictions, may also increase or reduce the various items. (See BUDGET SYSTEM, AMERICAN). Some charters empower the mayor to obtain reports from city officials at stated intervals, to inspect accounts and to conduct investigations; and some require the mayor's approval to validate contracts. In a few cities, when necessary, the militia may be called out by the mayor and in some cities persons convicted and fined in municipal courts may be pardoned by the mayor and he may also remit their fines. See CITIES, AMERICAN, GOVERNMENT OF; MUNICIPAL GOVERNMENT; CABINET AND CABINET GOVERNMENT; COMMISSION FORM OF GOVERNMENT; CITY MANAGER PLAN OF GOVERNMENT.

**Bibliography.**—Beard, C. A., 'American Government and Politics' (rev. ed., New York 1914), and 'Readings in American Government and Politics' (New York 1909); Bayles, G. J., 'The Office of Mayor in the United States' (New York 1895); Bondy, W., 'The Separation of Governmental Powers' (in 'Columbia University Studies,' Vol. V, No. 2, New York 1896); Blue, L. A., 'Relation of the Governor to the Organization of Executive Power in the United States' (Philadelphia 1902); Bryce, James, 'American Commonwealth' (rev. ed., New York 1914); Belmont, Perry, 'Cabinet Officers in Congress' (in *North American Review*, Vol. CXCVII, pp. 22-30, January 1913); Bradford, G., 'The Lesson of Popular Government' (New York 1899); Croly, H., 'Promise of American Life' (New York 1912); Durand, E. D., 'Council vs. Mayor' (in *Political Science Quarterly*, Vol. XV, pp. 426-51, 675-709, 1900); Eaton, D. B., 'The Government of Municipalities' (New York 1899); Fish, C. R., 'The Civil Service and the Patronage' (New York 1905); Finley, J. H., and Sanderson, J. F., 'The American Executive and Executive Methods' (New York 1908); Ford, H. J., 'Cost of Our National Government' (New York 1910); Fairlie, J. A., 'The National Administration of the United States' (New York 1905), 'Municipal Administration' (New York 1910), and 'The State Governor' (in *Michigan Law Review*, Vol. X, 1912); Greenlaw, E. A., 'The Office of Mayor in the United States' (in *Municipal Affairs*, Vol. III, pp. 33-60, New York 1899); Gauss, H. C., 'The American Government' (New York 1908); Garner, J. W., 'Introduction to Political Science' (New York 1910), and 'Government in the United States, National, State and Local' (New York 1914); Grant, A. H., 'The Office of Mayor' (in *The American City*, Vol. IV, pp. 25-26, New York 1911); Gettell, R. G., 'Readings in Political Science' (Boston 1911); Goodnow, F. J., 'Municipal Government' (New York 1910), 'City Government' (New York 1904), and 'Principles of American Administrative Law' (New York 1905); Hatton, A. R., 'Digest of City Charters' (Chicago, 1906); Hart, A. B., 'Actual Government' (rev. ed., New York 1909); McLaughlin and Hart (eds.), 'Cyclopædia of American Government' (New York 1914); Mason, E. C., 'The Veto Power' (Boston 1890); Munro, W. B., 'Government of Amer-

ican Cities' (New York 1913), and 'Bibliography of Municipal Government' (Cambridge, Mass. 1915); Powell, T. R., 'Separation of Powers; Administrative Exercise of Legislative and Judicial Power' (in *Political Science Quarterly*, Vol. XXVII, pp. 215-238, June 1912, and Vol. XXVIII, pp. 34-48, March 1913); Reinsch, P. S., 'Readings in American State Government' (Boston 1911); Salmon, L. M., 'History of the Appointing Power of the President' (New York 1886); Story, J., 'Commentaries on the Constitution' (5th ed., Boston 1890); Taft, W. H., 'Four Aspects of Civic Duties' (new ed., New York 1906); White, F. H., 'Growth and Future of State Boards and Commissions' (in *Political Science Quarterly*, Vol. XVIII, pp. 631-656, 1903); Woolsey, T. D., 'Political Science' (2d ed., New York 1893); Wilson, Woodrow, 'Congressional Government' (15th ed., Boston 1900), and 'Constitutional Government' (New York 1908); Willoughby, W. W., 'Constitutional Law of the United States' (New York 1910).

IRVING E. RINES.

**EXECUTIVE AND JUDICIARY**, those branches of government which, respectively, are entrusted with the execution of the laws, and that judge or determine the application of the laws to particular cases, their constitutionality, etc. See COURT; EXECUTIVE; STATE.

**EXECUTIVE OFFICER**, in the navy of the United States the officer of the line next in rank to the captain. His appointment is usually direct from the Navy Department, but in some cases a senior officer is detailed as executive officer by the captain. On the larger vessels this officer is generally of the rank of commander, but in the smaller vessels is of lower rank. He is the aide and executive of the captain in all matters and is responsible for all drills and routine work. He has charge of the enlisted force and keeps their records. In battle the executive officer has general supervision of the battery and of everything in regard to the safety of the ship except navigation. While on board he has general supervision of the organization, discipline, exercise, etc., of the crew.

**EXECUTIVE POWER**, narrowly defined, is that power which enforces law. In its larger aspect it involves the exercise of wide discretion and judgment, the rendering of important decisions, and the formulation and carrying out of constructive policies. The executive directs the public life of the state, and in all relations with foreign states is its representative. The principal function of the executive is to administer and enforce the will of the state as formulated by the legislature. The executive should be characterized by prompt decision, singleness of purpose and energetic action, objects which are only obtained by vesting the executive power in the hands of a single person. See EXECUTIVE; GOVERNMENT; GOVERNOR; STATE; PRESIDENT.

**EXECUTIVE REFORM**. See EXECUTIVE; STATE.

**EXECUTOR** (Lat. "performer"). An executor is one to whom another man commits his last will and testament for execution of that last will and testament (2 Black. Comm. 503). A person to whom a testator by his will commits the *execution* or putting in force of

that instrument and its codicils. The following is a brief summary of an executor's duties:

(1) He must bury the deceased in a manner suitable to the estate left behind. But no unreasonable expenses will be allowed, nor any unnecessary expenses if there is risk of the estate's proving insolvent. (2) Within a convenient time after the testator's death, he should collect the goods of the deceased, if he can do so peaceably; if resisted he must apply to the courts for relief. (3) He must prove the will, and take out administration papers. (4) Ordinarily, he must make an inventory of personal property, and in some States of real estate also. (5) He must next collect the goods and chattels, and have the claims inventoried, with reasonable diligence. And he is liable for a loss by the insolvency of a debtor, if it results from his gross delay. (6) He must give notice of his appointment in the statutory form and should advertise for debts and credits. (7) The personal effects he must deal with as the will directs, and the surplus must be turned into money and divided as if there was no will. An administrator must at once collect, appraise and sell the whole. The safest method of sale is a public auction. (8) He must keep the money of the estate safely, but not mixed with his own, or he may be charged interest on it. (9) He must be at all times ready to actually file an account within the year generally prescribed by statute. (10) He must pay the debts and legacies in the order required by law. Funeral expenses are preferred debts. See ESTATE.

**EXECUTORY DEVISE**, a bequest by testament of a future interest of real or personal property, which is such that it may not be described as a residuary estate. It must take effect within a life or lives in being and 21 years after. See DEVISE; FUTURE ESTATE.

**EXEDRA**, a seat built out from a portico in Greek and Roman buildings. Such seats were usually semi-circular in form and sometimes were provided with a roof. Famous examples of exedras built out of doors were those in the Street of Tombs, Pompeii. The Sieges-Allée, Berlin, contains modern examples of this kind.

**EXEGESIS**, Biblical. The word "exegesis" is from the Greek *ἐξηγησις*, primarily a *leading out*, and coming to mean, *an interpretation, an explanation, a making clear*. The verb *ἐξηγήσατο* occurs six times in the New Testament, always in the sense of revealing a fact or of making clear a truth, Luke xxiv, 35; John i, 18; Acts x, 8; Acts xv, 12, 14; Acts xxi, 19. In John i, 18, we read, "No man hath seen God at any time; the only-begotten Son, who is in the bosom of the Father, that one became his exegete" (*ἐκεῖνος ἐξηγήσατο*). That is to say, Jesus revealed the inmost character of God. He *made manifest* what otherwise would have remained hidden. He *interpreted God's* being. He *made clear* the Divine providence and plan. His person and his whole teaching and life were an exegesis of the invisible and previously incomprehensible Godhead. What Jesus did for God's being and providence, the exegete endeavors to do for the Bible. He searches for its inmost meaning, explains what is obscure, leads out to the light what is less manifest, makes clear all its implications and

sets its complete import before the mind's eye. The task of Biblical exegesis, therefore, is to clear up all difficulties and to make plain the meaning of the Bible text. It might seem a comparatively easy thing to do this; but centuries of endeavor have shown that while all the essentials of the revelation in the Bible are reasonably clear there are problems connected with all of the Bible books which tax the utmost powers of the greatest minds to master them. Then at least four temptations beset the interpreters of Bible truth. One of these is apparent in those exegetes who

"Each dark passage shun  
And hold their farthing candle to the sun."

What is clear in itself needs no further explanation. The office of the exegete becomes a necessity only when the meaning seems obscure. Another danger in exegesis is that of bringing a meaning to the text instead of drawing the meaning *from* it. The text is forced into agreement with previous prejudice or opinion. This is nearly always fatal to the truth. As an old monk said, "Whosoever seeketh an interpretation in this book shall get an answer from God; whosoever bringeth an interpretation to this book shall get an answer from the devil." Jerome put the same truth more mildly when he said, "He is the best teacher who does not bring his doctrine into the Scripture but out of the Scripture." Sometimes the obvious meaning of the text is unpalatable to the exegete, for doctrinal or other reasons, and then he is tempted to explain the meaning away. This is rankest treason to his calling. He is expected to be loyal to the truth and nothing but the truth. If he betray the truth in behalf of a political party or a church organization or a doctrinal system he is no longer worthy of his office or name. A fourth temptation is that of adding to that which is written, improving upon the text by the addition of unwarrantable inferences and subjective fancies and unjustifiable subtleties of every sort. It represents the presumption of the apostle Peter at Cæsarea Philippi, who thought he knew better than his Lord what ought to be said and done. These are four fundamental faults of all exegesis; a failure to explain the meaning that is obscure, a distorting of the meaning that seems obvious, an utter perversion of the plain truth, and a supplanting of the truth with merely human verbiage or wisdom. Wilful miscarriage, maiming, murder and the substitution of a changeling for the true child are crimes in the realm of interpretation, as well as under the civil law. The science of exegesis has sought from the first to free itself from these faults. If it has not wholly succeeded as yet, that is simply to acknowledge that like all other science its development has been entrusted to fallible men. We may trace various schools of exegesis through the history of the Church, and in all of them some one or other of these fundamental faults is likely to be manifest.

The first important school of exegesis was founded at Alexandria, and it flourished from 150 to 400 A.D. Its most distinguished representatives were Clement, Origen, Athanasius, Basil and the two Gregories. Of these the peerless prince was Origen, the greatest scholar and saint the Christian Church has produced since apostolic times. A great injustice has been done both him and the Alexandrian school

by associating their names almost exclusively with the allegorical interpretation of the Scriptures, in which they sometimes indulged, as though this method were their only method or were peculiar to them alone. Neither of these things were true. The allegorical interpretation was much older than the Alexandrian school and has persisted in dragging out its pernicious existence to this day. It was prevalent and predominant in the Rabbinical schools of exegesis before the Christian era began. The Talmudists finally found a watch-word for their mystical exegesis in Pardes, or Paradise. The four letters of this word in the Hebrew, P R D S, were made to indicate the four words, Peshat or explanation, Remes or hint, Darush or homily, and Sod or mystery; and these in turn represented the fourfold interpretation of which every passage in Scripture was capable. Rabbi Ishmael declared that by means of these any Scripture could be expounded in 49 ways and the expositor could break every text into fragments even as a rock is broken by a hammer (Sanhedrin, 34). The apostle Paul carried at least one example of allegorical treatment into our New Testament, probably suggested by his Jewish training in the school of Gamaliel, Gal. iv, 22-31. This method was introduced into Alexandria by Aristobulus and pseudo-Aristeas, and it became authoritative as a method of exegesis under Philo, the foremost writer among the Alexandrian Jews contemporary with the Christ. Philo found the method ready made to his hand, not only by the Jewish rabbis, but also by the Greek philosophers who had allegorized Homer and Hesiod and the ancient Greek myths into conformity with their more advanced ethics and faith. The Alexandrian Church fathers thus found the allegorical interpretation in vogue among their heathen and Jewish neighbors and forbears. They believed it had a Scriptural sanction. They accepted it without question. Their genius and wide influence gave it a standing in the Christian Church for centuries; but the Alexandrian school never had a monopoly of its use. It is unfair, therefore, to hold them responsible, either for the origination or for the promulgation of this method of Scriptural interpretation. Origen did teach that there was a threefold sense in Scripture, corresponding to the body, soul and spirit in man—a literal and a moral and a mystical sense. But Jerome also made it a rule that the Scripture should be interpreted in three ways, historically, tropologically and spiritually; and he related this threefold division to the doctrine of the Trinity. And Augustine formulated one principle of his exegesis in these words, "Whatever there is in the word of God that cannot, when taken literally, be referred either to purity of life or soundness of doctrine, you may set down as figurative" ('De Doctr. Christ. III, ch. 10, sect. 14). He wrote to Honoratus, "All that Scripture, therefore, which is called the Old Testament, is handed down fourfold to them who desire to know it, according to history, according to etymology, according to analogy, according to allegory" ('De util. credendi,' 5). This fourfold division was adopted by many of the church fathers and found its final formulation in the famous couplet of Nicholas of Lyra.

Littera gesta docet, quid credas Allegoria,  
Moralis quid agas, quo tendas Anagogia

A good example of this fourfold sense was the Scriptural use of the word, Jerusalem. Literally it was a city; allegorically, the church; morally, the individual believer; anagogically, the heavenly state.

This much may be said for the Alexandrian school in connection with the allegorical interpretation of the Scripture. (1) It did not originate this method. (2) It never exercised any monopoly in its use. (3) It found what seemed to be a sufficient sanction in the typology and allegory of the Apocalypse, the Pauline epistles, and the epistle to the Hebrews. (4) No other method of interpretation would have availed them, in their stage of Biblical knowledge and in their environment, for the defense of many portions of the Old Testament. Their adequate apology for yielding to the fourth temptation mentioned above is to be found in the necessities of their case. (5) Their use of this method grew out of their very piety and spirituality. These simply joined forces with their poetical imagination and philosophical insight in the endeavor to save the Scripture from contemporary disrepute. (6) They never used the allegorical method dogmatically and they avoided most of the excesses of the later day. "They are always intelligent and reasonable. They evaporated the letter; they did not stereotype the spirit" (Bigg, 'Christian Platonists of Alexandria,' pp. 149-150). Making all allowance for fault at this point, the fact remains that "Origen was the greatest Biblical critic and exegete of the ancient church" (Terry, 'Biblical Hermeneutics,' p. 639). His one object was to find and set forth the edifying truth in the Scripture. He said, "The passages that are true in their historical meaning are much more numerous than those which are interspersed with a purely spiritual signification." Having adduced many passages in which a literal meaning seems impossible, he concludes, "Therefore the exact reader must, in obedience to the Savior's injunction to search the Scriptures, carefully ascertain in how far the literal meaning is true, and in how far impossible; and so far as he can, trace out, by means of similar statements, the meaning everywhere scattered through Scripture of that which cannot be understood in a literal signification" ('De Principiis,' IV, 1; 19). This is seen at once to be, as Davidson said, "not so absurd or injurious as many represent" ('Sacred Hermeneutics,' p. 68). Bishop Lightfoot is fully justified in saying of Origen, "A very considerable part of what is valuable in subsequent commentaries, whether ancient or modern, is due to him. A deep thinker, an accurate grammarian, a most laborious worker, and a most earnest Christian, he not only laid the foundation, but to a very great extent built up the fabric of Biblical interpretation" ('Commentary on Galatians,' p. 227). Farrar declares, "His knowledge of the Bible and his contributions to its interpretation were absolutely unrivaled" ('History of Interpretation,' p. 188). Fairweather adds, "Properly speaking, Origen was the first exegete. Everything done in this direction previously had been merely preparatory to a scientific interpretation of Scripture. . . . One of the great merits of Origen is that he never shirks a difficulty. . . . Nothing could exceed his passion for verbal and grammatical accuracy, or his linguistic and critical insight, while his knowledge of

the ancient theology is unique" ("Origen," p. 120). Harnack calls Origen "the father of ecclesiastical science in the widest sense of the word," and says that he "was an exegete who believed in the Holy Scriptures and indeed, at bottom, he viewed all theology as a methodical exegesis of Holy Writ" ("History of Dogma," II, pp. 332, 335). In Origen, therefore, we find the founder of scientific exegesis and the great master in this field. His faults were those of his age; his excellences have been an abiding blessing to the Church. Our age is coming to agree with Gregory Thaumaturgus in his Panegyric, when he says of Origen as an exegete, "That greatest gift that man has received from God, and that noblest of all endowments, he has had bestowed upon him from heaven, that he should be an interpreter of the oracles of God to men, and that he might understand the words of God, even as if God spake them to him, and that he might recount them to men in such wise as that they may hear them with intelligence. . . . He explained whatsoever was dark and enigmatical, . . . and set it in the light, as being himself a skilled and most discerning hearer of God. . . . He alone of all men with whom I have myself been acquainted, or of whom I have heard by the report of others, has so deeply studied the oracles of God, as to be able at once to receive their meaning into his own mind, and to convey it to others. For that leader of all men, who inspires God's dear prophets, and suggests all their prophecies and their mystic and heavenly words, has honored this man as He would a friend, and has constituted him an expositor of these same oracles; the things of which He only gave a hint by others He made matters of full instruction by this man's instrumentality; and in things which He, who is worthy of all trust, either enjoined in regal fashion, or simply enunciated, He imparted to this man the gift of investigating and unfolding and explaining them; so that, if there chanced to be anyone of obtuse and incredulous mind, or one again thirsting for instruction, he might learn from this man, and in some manner be constrained to understand" (Argument, XV). It is the picture of the perfect pattern of the union of scientific investigation and spiritual insight which makes the model exegete. The transcendent genius of Origen lifted him above his age at many points, and the 20th century is beginning to see that his conception of revealed truth is far superior to that of most of his successors in the history of the Church.

It has been customary to denounce Origen and the Alexandrian school for their indulgence in allegory and to contrast with them most favorably the next great school of exegetes at Antioch. The most distinguished names here were those of Lucian, Diodorus, Theodore, Theodoret, and Chrysostom. We are told that these men were literalists rather than allegorists. They held rigidly to the historical and grammatical sense and it is but natural that the historical and grammatical critics of the 19th century should applaud their opposition to the allegorical flights of the Alexandrians. However, it is well for us to remember that this school has its dangers and faults as well as the Alexandrian. Its literalism resulted in a rationalism which was like a dry rot in the Church. Historically, it led directly to Arianism,

which threatened to cut the tap-root of the Christian faith; and against this the orthodox exegesis of Athanasius the Alexandrian, proved to be the only safeguard of the Church at the last. Its tendency was to narrowness, rather than to richness. What it gained in straitness, it lost in breadth. However, among all the Greek fathers, Chrysostom will rank next to Origen in uniting the best characteristics of both schools. "Through a rich inward experience he lived into an understanding of the Holy Scriptures; and a prudent method of interpretation, on logical and grammatical principles, kept him in the right track in deriving the spirit from the letter of the sacred volume" (Neander, 'History of the Christian Religion and Church,' II, p. 693). Origen and Chrysostom had no worthy successors in the next millennium of church history. Jerome has been called the Origen of the Western Church but he was too hasty in composition, too much influenced by his personal prejudice, and too vacillating and uncertain in his own opinions to deserve this name as an exegete. His services in other directions were invaluable. He was the greatest scholar in the West as Origen had been the greatest scholar in the East; but he lacked the depth of character, the consistency of principle, and the consequent spiritual intuition of that greatest master in the early Church.

Augustine has exerted a wider influence upon the Christian Church than any other of the church fathers. He was the chief authority through the whole of the mediæval age. Martin Luther was an Augustinian monk at the time of his conversion; and he and Melancthon and Calvin and Bucer all built upon the foundations which Augustine had laid down. The works of the great Latin father have been read and revered by Protestant and Roman Catholic alike, and it is only in our day that serious question has arisen as to his right to continued supremacy. In the present reaction from the theology of the Latin fathers to the older and purer theology of the Greek fathers, it is in the field of scholarly exegesis that the inferiority of Augustine becomes most apparent. He was not even equal to Jerome in scholarship. He knew no Hebrew. He was very deficient in his knowledge of the Greek. He preferred a translation to the original text. He was continually making mistakes as to the meaning of words. He had all the defects of his predecessors, without their excuse for them. The Alexandrians had been driven into the use of allegory to harmonize the Gospel teaching with the truth of Greek philosophy and to command the hearing and respect of their Jewish contemporaries. But Augustine was an allegorist of the allegorists when no necessity was laid upon him and when allegory had degenerated into mere imaginative ingenuities. Augustine had genius and a genuine Christian experience and consequently flashes of illuminative interpretation are found in his books, but these cannot compensate for the lack of the critical faculty and a sound basis of linguistic scholarship in exegesis. "Spiritual insight though a far diviner gift than the critical faculty, will not supply its place. In this faculty Augustine was wanting, and owing to this defect, as a continuous expositor he is disappointing" (Lightfoot, 'Commentary on Galatians,' p. 233). His total influence has been an immeasurable bane

to Christendom. He was chiefly responsible for subordinating exegesis to ecclesiastical authority. He said, "For my part, I should not believe the gospel except as moved by the authority of the Catholic Church" ('Ep. c. Manich.,' ch. 5, sect. 6). He declared, "Now Scripture asserts nothing but the Catholic faith" ('De Doctr. Christ.' III, ch. 10, sect. 15), and he bent his exegesis to make good that declaration. He fastened upon the Christian Church the dogmas which have been the chief hindrances to its progress for 1,400 years; "the exaggerated doctrine of total human depravity," the guilt of innocent infancy, arbitrary election involving a practical denial of the freedom of the human will, atonement by quantitative equivalence in suffering, the subtle systematization of divine counsels and schemes, the imperious necessity of sacerdotalism and sacramentarianism, intolerance of opinion contrary to churchly authority, even when based upon an earnest and intelligent study of the revealed Word. Following his lead the Church has floundered for centuries through sloughs of despond and has almost forgotten the broader horizon and the fresher air of the high table-lands of the earlier theology. Among the Greek fathers no one of these questions which have afflicted our Latinized Christianity found an atmosphere congenial enough in which to thrive. We owe much to Augustine but it is hard for us to believe that his good influence can begin to equal his evil influence upon the Christian Church. His is the last great name among the church fathers. For a thousand years little or no progress was made in the interpretation of the Scriptures.

The Schoolmen contented themselves for the most part with copying and compiling the work of their predecessors in this field. It became a proverb among them, *Si Augustinus adest sufficit ipse tibi*. One of them stated plainly that no interpretation of Scripture must be accepted which ran counter to the authority of the Church, "however much such a sense may be in conformity with the literal meaning. Indeed that ought not to be called the literal sense which is repugnant to ecclesiastical authority" (Paulus of Burgos, 'Prol. in Additiones'). Even Gerson declares, "The literal sense must be judged according as the Church has determined" (Propp. de sens., lit. 3). With no independence of thought and with no fresh scholarship the schoolmen added no new principle of exegesis in a thousand years of commentary writing. They were expending their energies upon subtle and futile speculations. They composed great folios which aimed at nothing original and arrived nowhere in particular. They labored hard in a treadmill. They were weakest in exegesis. Only two or three of them knew any Hebrew, and most of them knew very little if any Greek. They were unoriginal, uncourageous, uncertain, uninformed. They had a wrong notion of the Church and a wrong conception of inspiration, and it naturally followed that they had a wrong method of exegesis. They had their merits too, but not as exegetes.

With the Protestant Reformation we come to a new era in Scriptural exegesis. Coleridge said of the Reformers, "The least of them was not inferior to Augustine and worth a brigade of Cyprians, Firmilians, and the like" ('Remains,' III, p. 276). Calvin sweepingly asserts,

"Modesty will not allow me to speak of ourselves as fact would justify; and yet I will most truly declare that we have thrown more light upon the Scriptures than all the doctors who have appeared under the Papacy since its commencement. This praise even they themselves dare not deny us" ('Antid. in Conc. Trid.' Sess. IV). The Bible seemed like a fresh discovery to the Church of that day. For the first time it became the property of the common people; and the printing press made it possible for it to become a common possession. It had been locked up in the Latin tongue and was supposed to be the peculiar property of the priests. Translations now made it accessible to all and the Protestant preachers constantly appealed to its authority in their opposition to the usurpations and the abuses of the hierarchy. That necessitated a renewed study of the sacred text on both sides. It soon became impossible for a man to be a doctor of divinity for eight years, as Carolstadt confessed that he had been, before he had read his New Testament. The Protestants delighted to circulate such stories as that of Sixtus of Amana concerning Albert, archbishop of Mayence, who read a few pages in the New Testament and then put it down, saying, "I know not what book this is, I only see that all things contained in it are hostile to us" ('Antibar. Bibl.' II, 7). The churchmen and schoolmen had always based their doctrinal systems upon the Bible, but the stereotyped interpretation of the Scriptures had come to claim the authority of the Scriptures themselves. John Nathin said to Martin Luther in the convent at Erfurt, "Brother Martin, let the Bible alone; read the old teachers; they give you the whole marrow of the Bible; reading the Bible simply breeds unrest" (Lindsay, 'History of the Reformation in Germany,' p. 200). Heresbach the friend of Erasmus, heard it said that the study of the original Greek was the prolific source of all heresies, while the study of Hebrew turned men into Jews at once. (D'Aubigné, I, ch. 3). It was deemed dangerous for the layman to attempt to understand the Scripture for himself; it was his duty to accept the interpretation of the book by the Church. It was at this point that the protest was made; and all the Reformers insisted that the Bible ought to be open to every man and that the Spirit of God would help every man to a safe and sufficient understanding of its contents. Luther came to take the position that no external authority could decide what was Scripture or what was the meaning of Scripture. He said, "How can we know what is God's Word and what is true or false? . . . Who decides me there? No man, but only the truth which is so perfectly certain that nobody can deny it" (Dods, 'The Bible, Its Origin and Nature,' pp. 38-40). Calvin said, "Scripture is self-authenticated, carrying with it its own evidence. . . . It obtains the credit which it deserves with us by the testimony of the Spirit" ('Institutio,' I, 7; 5). Over against this position may be put the words of Lacordaire, "What kind of a religion is that which saves men by aid of a book? God has given the book, but He has not guaranteed your private interpretation of it. . . . If there be a true religion on earth, it must be of the most serene and unmistakable authority" (cf. Lindsay op. cit., p. 457). That authority is not,

according to Lacordaire, found in private judgment but in the infallible decree of Pope or Councils. Such was the issue drawn by the Reformation, both parties claiming the authority of the Scriptures, the one as interpreted by the Church for all, and the other as interpreted by the Spirit to each man. It was equally incumbent upon all concerned to show that their interpretation was a true one. This battle over the Book led to such searching of the Scriptures as had not been seen in the Church in any period of its history.

The way was opened for an intelligent discussion of the Scripture text largely by the labors of Erasmus of Rotterdam. His edition of the Greek Testament became the standard text among the reformers. His translations, annotations and paraphrases entitle him to high rank as an exegete. He was independent in judgment, characterized by good sense, and a philologist without a peer. His aim was to make the meaning of the Word perfectly clear to all. He said, "I do not see why the unlearned are to be kept away, especially from the evangelical writings, which were proclaimed alike to learned and unlearned, equally to Greeks and Scythians, as much for slaves as for the free, at the same time to men and to women, not less to peasants than to kings" ('Praef. in Paraph. in Matt.'). Erasmus still clung to the mystical or allegorical interpretation of certain Scriptures and thought that the Holy Spirit had intended that some words should carry multiple meanings. It was Martin Luther who broke finally and conclusively with this ancient error. He deserves highest honor as an exegete as well as a reformer by the enunciation of this principle, "Each passage has one clear, definite and true sense of its own. All others are but doubtful and uncertain opinions." He added, "The literal sense of Scripture alone is the whole essence of faith and of Christian theology. . . . Allegories are empty speculations. . . . An interpreter must as much as possible avoid allegory that he may not wander into idle dreams. . . . To allegorize is to juggle with Scripture. . . . If we wish to handle Scripture aright, our one effort will be to attain *unum, simplicem, germanum, et certum sensum literalem*" ('Commentary on Genesis'). Unlike Jerome and so many others who had recognized these truths before him, he is true to these principles in his own exegesis. He published 'Notes' on many portions of the Scripture, and a complete 'Commentary on Galatians.' His exegetical works were published in a score or more volumes in both Latin and German, and were of paramount influence in introducing better methods of exegesis in the Reformed Churches. Melancthon, Bucer, Zwingli, Beza and many others did notable work in exegesis in the Reformation period; but their books are for the most part unread to-day. The greatest exegete among the reformers was John Calvin. He wrote complete commentaries on nearly the whole of the Bible. The single exception in the New Testament was the book of the Apocalypse; and Judges, Ruth, Kings, Esther, Ezra, Nehemiah, Proverbs, Ecclesiastes, and Song of Solomon were the only books left untouched in the Old Testament. His commentary on the Psalms was justly celebrated for its religious insight; and in the Pauline epistles and the book of Acts he is

at his best in the New Testament. He wrote to his friend Grynaeus in 1539, "We were both of this mind, that the principal point of an interpreter did consist in a plain briefness. . . . We wished that there might be some one who gave his diligence not to trouble those who are desirous of learning with long commentaries" ('Praef. in Rom.'). This suggests one chief excellence of Calvin's exegetical work. It is clear and concise and not loaded down with references to a host of other authorities. Calvin has the learning necessary for his task, but he makes no needless display of it. He uses it simply to present plainly the meaning of the text. He was honest and independent in his comment, intelligent in his method and comparatively free from the worst faults of all his predecessors in this line. He never agreed with Luther as to the adequacy of the private judgment; and yet he was a persecutor of those who did not agree with his own views. The prejudices of his peculiar theology appear throughout his commentaries, and the repudiation of his conception of the decree as the central idea of Christianity has gone far to detract from his use and usefulness in the America of the 20th century. However he is still worth consulting for his good sense in most things and his good style in all.

It seemed a necessity of the age that all Christians should be dogmatists, and Protestant dogmatism soon became as deadly an influence in the field of exegesis as Roman Catholic tradition had ever been. The successors of the great Reformers were like the schoolmen who succeeded the great Fathers of the early Church. They were subservient to authority and fettered by dogma; and in the 17th and 18th centuries very few exegetes appeared whose works are read to-day. The scholarship of the elder Lightfoot is valued. The practical comments of Robert Leighton on First Peter are still enjoyed. John Owen's Exercitations on the Epistle to the Hebrews is a monument of erudition and pious reflection; but, like Caryl on Job, it is too voluminous to hold attention in this modern age. Robert Hall said of Owen, "He always takes for granted what he ought to prove, while he is always proving what he ought to take for granted; and after a long digression, he concludes very properly with, This is not our concernment; and returns to enter upon something still farther from the point." Adam Clarke added, "To me he is one of the most unsatisfactory of writers. His sense and meaning he drowns in a world of words. He cannot condense his meaning, and never comes to the point, but by the most intolerable circumlocution" (Etheridge, 'Life of Adam Clarke,' pp. 317-318). He may stand as probably the last example the world will ever see of such intolerable prolixity. Arminius and Grotius introduced the reaction from Calvinistic and Lutheran and Augustinian exegesis, which has been gathering force ever since and which has about come to its triumph in America. Cocceius and Vitringa in their opposition to scholasticism and dogmatical bias furnished a series of commentaries with many excellent qualities, but reverting too far in the direction of the mystical or allegorical interpretation. Bengel's Gnomon is a model of brevity and learning in exegesis. Philip Schaff calls it "a marvel of *multum in parvo*." Henry, Scott

and Adam Clarke wrote devotional commentaries which are still in use. Ernesti has been regarded as the founder of a new exegetical school, attempting to hold the *via media* between the allegorists and the dogmatists. His exegesis was predominantly grammatical. Semler, pietist and rationalist, introduced the historic method of exegesis, and prepared the way for the unparalleled exegetical activity of the 19th century. The most dominant influence in the 19th century in the whole field of theology was that of Schleiermacher. He was the founder of what has been called the psychological school of exegesis. He was both rationalistic and supernaturalistic in his interpretation of the Scriptures. He appealed to opposing classes and did much to bring all Germany back to a central emphasis upon the person and teaching and influence of Christ. In Germany and, through Coleridge and Maurice, in England and America his spirit and methods have been fruitful of much good in Biblical study. "Church history offers no parallel to him since the days of Origen" (Farrar, 'History of Free Thought,' p. 244). He was the "Plato and Origen of Germany in the 19th Century" (Philip Schaff). He based his religion upon faith and feeling, and he made the Christian consciousness and personal experience the guiding lights of his Scriptural interpretation. He claimed a Divine compulsion in his teaching and spoke and wrote with prophetic fervor and authority. He said, "Divinely swayed by an irresistible necessity within me, I feel myself compelled to speak. . . . Nor is it done from any caprice or accident. Rather. . . it is a divine call" ('Reden über die Religion,' I). His personal magnetism and pronounced genius, his eloquence and earnestness, the genuineness of his Christian experience, the remarkable breadth of his vision and thought, and the intensity of his spiritual zeal gave him a most extraordinary influence upon his own and succeeding generations. He vindicated the right of Christian experience to an equal hearing with the results of any purely scientific research. His spirit pervades the Christian world to-day and will maintain its permanent place in Christian thought. De Wette was the greatest exegete among the disciples of Schleiermacher. His work represents prodigious learning and "perfect loyalty in the search for truth" (Godet). He expresses himself clearly, but does not always come to a desirably definite conclusion. Credner occupied practically the same standpoint.

The year 1835 marked a new era in all scientific Bible study (Pfleiderer, 'Development of Theology,' p. 209). In that year Strauss published his 'Life of Jesus,' Baur, his work on the 'Pastoral Epistles,' and Vatke, his 'History of the Religion of the Old Testament.' Each of these books may be regarded as epoch-making.

Eichhorn has reduced the rationalistic treatment of the Scriptures to a scientific system. Strauss was the first to put this rationalism into concrete and popular form. Baur was the founder of the Tübingen or Tendency school, which probably represented in Germany the greatest theological movement of the century. Baur endeavored to bring all his exegesis to the bar of historical investigation. He examined all traditional exegesis critically and subjected the New Testament books to a more thorough-

going analysis than they had ever known. He emphasized the theological standpoint of each writer, and he thought he detected an irreconcilable antagonism between the Pauline and the Petrine wings of the Christian Church. He stimulated Bible study to an astonishing degree. His personal power was manifest in the remarkable group of disciples he gathered about him. Among these we may mention Zeller, Schwegler, Hilgenfeld, Holsten, Pfeiderer and Volkmar. The entire movement inaugurated by Baur has been characterized by comprehensive and accurate scholarship, the value of which has been somewhat impaired by the critical presuppositions upon which it was based. Strauss came over into this school in the second edition of his 'Life of Jesus.' Ritschl began his career in it, but later swung clear of it and became the founder of a distinct school of thought, to which Harnack, Jülicher, Kaftan, Hermann and Von Soden adhere.

Ritschl claimed to repudiate all metaphysical presuppositions and to found his system on the religious consciousness alone. He believed that the primitive faith sprang from the person and word of Jesus, with no philosophical alloy in the beginning. He held that experience limits the domain of knowledge. The Scriptures are sufficient in themselves to reveal the spiritual and moral worth of the kingdom of God, whose end is realized in love. Dogmatics and ethics unite in the higher synthesis of the revelation of the New Testament. Frank was the most determined opponent of Ritschlianism in Germany. He pointed out the lack of a true and deep conception of sin in this system of thought, and its consequently inadequate notion of atonement and conversion; and he claimed that, instead of rejecting metaphysics, the whole system was based on a 'highly developed but false and contradictory metaphysics of its own.

Vatke in 1835 outlined the revolution which has since taken place in the conception of Old Testament history. His book, however, was overloaded with philosophical terminology and met with no general appreciation and soon seemed to be forgotten. Reuss lectured along the same lines at Strassburg, and two of his pupils, Graf and Wellhausen, published the new hypothesis of the development of Old Testament ritual and literature. It was Vatke's theory brought to life again, and it has exercised increasing influence upon the exegesis of all the Old Testament books for the last half century. The prophets have come into new prominence as a result of this study. They are recognized as the founders of the Hebrew religion. The Law in its present form was of later growth in the Jewish Church. The Pentateuch has been resolved into a number of documents. Deuteronomy is believed to belong to the times of Josiah. Isaiah and other prophetic books are shown to be of multiple authorship. The Psalms come last in the Hebrew sacred literature. Stade, Budde, Smend, Schultz and others have represented this school of thought.

Germany has been the great battle-ground of the Higher Criticism through the last century; and the exegetes have enrolled themselves among the critical and the traditional, the more radical and the more conservative camps. Neander the champion of spirituality, Hengstenberg the bulwark of orthodoxy, Delitzsch the

pre-eminent scholar, did valiant service for what they deemed the traditional truth. Just before his death Delitzsch seemed disposed to go over into the critical ranks. Dillmann and Gunkel have adopted the newer views. The indispensable commentary in the New Testament field has been that of H. A. W. Meyer. Characterized by grammatical rigor and literary freedom, and brought up to date by frequent revisions, it has maintained itself as a standard authority for two generations. The principal contributor to the later editions has been Bernard Weiss, the present prince of all laborers in the exegetical field. Having completed more than 50 years of University service he stands to-day without a peer in his record of worthy achievement as a textual critic and commentator. He is incomparable for minute and searching investigation, exactness and solidity of scholarship. His associates in the Meyer Commentary series have been Wendt, Heinrici, Sieffert, Schmidt, Düsterdieck and Beyschlag. Lipsius, Weizsäcker, Schmiedel and Holtzmann have represented the more advanced school of commentators. Bleek did most admirable work in the earlier part of the century and Luthardt and Hofmann have been conservative leaders in the latter days.

Among the Dutch theologians the dominant tendency in the last century has been toward extreme radicalism. Scholten and Kuenen have represented advance thought in the Old Testament field, while Loman, Pierson, Naber, Völter and Van Manen have been generally considered hypercritical in the discussion of New Testament questions. Steck has represented the latter school in Switzerland; while Godet has nobly upheld the traditions of orthodoxy in this land. Godet combines a French felicity of style with a German thoroughness of scholarship and adds to these a genuine spiritual fervor which makes his commentaries on Luke, John and Romans veritable masterpieces of exegesis. It may well be doubted if the century has produced more luminous and interesting contributions to this field.

France has furnished the brilliant and versatile and radical Renan, and the more profound and philosophical De Pressense; and it is making its influence felt to-day through the writings of the new Symbolo-Fideistic school, Stapfer, Sabatier and Ménégoz being the chief theological representatives. This school emphatically repudiates the infallibility of Pope or Church and just as emphatically renounces the infallibility of Scripture or the Christ recorded in Scripture. It believes that philosophy can never deduce any religious truth from its premises, and so repudiates rationalism as a foundation for faith. It believes in a Divine revelation through the immanent Spirit of God. It identifies prayer and religion. All expression of religious impression must be through images or symbols. "All religious formulas are symbolic formulas; and Dogmatic itself is a great system of symbols" (Ménégoz). The essence of the gospel is to be distinguished from what is merely contingent. Jesus is the perfect manifestation of God in man. Salvation is by faith and faith consists in repentance and heart-surrender to God. The advocates of this school confidently claim that the future belongs to them.

In Great Britain the century has furnished

some masterly exegetical work. Cambridge University has easily taken the honors in this field. Dean Alford in his 'Commentary on the Greek Testament' introduced the best results of German exegesis to English readers. Bishop Ellicott gave splendid examples of painstaking investigation of the Scriptural text. The great trio of later Cambridge scholars, Lightfoot, Westcott and Hort, have reached the high-water mark of English scholarship in their field. Bishop Lightfoot's commentaries upon the Pauline Epistles have been standard authorities ever since their publication. Westcott did equally fine work upon the writings of John and the Epistle to the Hebrews. Hort was generally reputed to be the greatest scholar of the three, but his extreme modesty and his realizing sense of the yet unattained perfection possible in his work kept him from the publication of any but fragmentary treatises. His influence lives among his students and associates. Mayor on James and Second Peter and Jude, and Swete on Mark and the Apocalypse are worthy companions of the other Cambridge University commentaries. Professor Davidson of Edinburgh was the leading Hebrew scholar of Great Britain in the century, and his pupils, W. Robertson Smith and George Adam Smith and others, have done yeoman service in revolutionizing and revitalizing the exegesis of the Old Testament. Sanday, Driver, Plummer, Beet, Findlay, Bruce and Dods have done excellent interpretative work. The 'International Critical Commentary' and the 'Expositor's Greek Testament,' bid fair to continue the best traditions in English exegesis.

America has had a share in the exegetical labor of the century. Moses Stuart, J. A. Alexander, Hackett, Hodge, Shedd, Harper, Mitchell, Moore, Toy, Vincent and others have produced exegetical studies of acknowledged merit. Albert Barnes, Henry Cowles, J. A. Broadus and D. D. Whedon have published series of helpful and devotional commentaries. Ezra Abbott, Edward Robinson, McGiffert, Mathews, Burton, Briggs, Bacon, Gilbert, Stevens, Allen and Smyth have done first-class service in special fields.

The Roman Catholic Church began the century with two most worthy representatives of Biblical learning. Hug ably combated the rationalistic tendencies of his day and defended the traditional views of the origin of the New Testament writings. Herbst performed the same service for the Old Testament. During the greater part of the century, however, free inquiry has been more or less stifled by the authority of "the usual exegesis of Scripture." Scientific research has been systematically discouraged and any tendency toward a new or modified interpretation of the Scriptural text and any originality of conclusions, such as may not be guaranteed by the authority of the Fathers and the Councils of the Church, have been frowned upon by those in the places of power. A better condition of affairs seems to be on the point of realization now. A growing body of students within the pale of the Church have felt the influence of the great onward movements in the Protestant world and are beginning to demand the privilege of free inquiry and the use of modern methods in exegesis. They point to the critical work in



the writings of Origen and Jerome and Eusebius and other Christian scholars and saints as proof that scientific research is no novelty in the Catholic Church, and they claim the right to follow in the footsteps of these illustrious critics of antiquity. A measure of freedom would seem to be already granted them since Pope Pius X wrote to Bishop Le Camus, "We should not approve the attitude of those who in no way dare to depart from the usual exegesis of Scripture, even when, faith not being at stake, the real advancement of learning requires such departure. You follow a wise middle course, and by your example show that there is nothing to be feared for the sacred books from the true progress of the art of criticism, nay that a beneficial light may be derived from it, provided its use be coupled with a wise and prudent discernment" (Dated 11 Jan. 1906). What this "wise and prudent discernment" may be is probably best illustrated in the decisions of the Biblical Commission appointed by Leo XIII, in its report upon the Pentateuch, published in the *Revue Biblique* and dated 27 June 1906. The report is presented in the form of questions and answers in catechism style. They may be summarized as follows: May one assert that Moses was not the author of the Pentateuch, but that it was made up largely of later elements? No. Must Moses then have written the whole of the Pentateuch with his own hand, or dictated it to secretaries? No. May Moses have committed the editing of it in whole or in part to secretaries and have permitted the publication of it under his name? Yes. May he have used sources, documents or oral traditions, borrowing sometimes the words, sometimes the sense? Yes. May the Pentateuch have undergone modifications, "additions made after Moses' death by an inspired author, glosses and parenthetical explanations, ancient words and phrases turned into more modern language, false readings to be attributed to errors of copyists, which criticism may examine and weigh according to its principles? Yes, the Church reserving judgment." The rights of the newer criticism to a hearing and standing in the Church are clearly allowed in this report, while the Church reserves the right to judge to what extent the findings of the critics may be compatible with its authority and peace.

Historical criticism has now come to the fore. The allegorical interpretation is discredited, it is to be hoped, finally and permanently. A vaster knowledge is at the service of the exegete than has been possible in any preceding age. The battles of the giants would seem to have ended for the time at least, and much of the smoke of conflict has cleared away. What ought the 20th century exegesis to be? It ought to be capable of the production of both popular and critical work. It ought to meet the demand for edification on the part of the most humble and unlearned; and at the same time it ought to be proficient in the most exhaustive scholarship. It has at its disposal the accumulated wealth of material collected in the preceding centuries; and it may profit by the defects as well as the excellences of the masters who have gone before. Biblical knowledge was never more profound or more prevalent than now. The original text has been determined within approximate accuracy. The

Bible has been freed from multiplied errors of manuscript transcription and restored to something like its original form and revelation. The original languages are better understood. The study of ancient inscriptions and fragments of newly discovered papyri have thrown a flood of light upon many new points. Modern travel and exploration and excavation in the Orient have taught us many things concerning the manners and customs of the ancient times. The marvelous advance made in the last century along the lines of scientific investigation and metaphysical research and literary criticism has had its beneficial influence upon the interpretation of the Bible. The exegete of to-day has an unprecedented equipment, and his task is comparatively clear. To-day, "the great body of evangelical expositors are united on the fundamental principles of interpretation. They agree that a proper commentary on the Bible or on any part of it should clearly set forth the true meaning of the words and the train of thought intended by the sacred writer; and it should point out the grammatico-historical sense of every passage, giving careful attention to the context, scope, and plan" (Terry, 'Biblical Hermeneutics,' p. 738). The great exegetical works of the present are characterized by directness, accuracy, learning, independence of research, a careful consideration of the context and all the light that historical and literary criticism can throw upon the theme. There is a better conception of the nature of inspiration and more freedom in the exercise of the critical faculties of the commentator. Rationalism has come to its rights, together with a recognition of the due restraint laid upon the student of a divine revelation. Having escaped from the tradition of an absolutely inerrant text and a form of revelation infallibly fixed for all time, the exegete of to-day is freer to turn from the letter that killeth to the spirit that maketh alive. The tendency of the times seems to be away from the dominance of the Latin and the Reformation theology to the purer exegesis of the primitive faith. With the broader spirit of the Greek fathers and the better critical apparatus of the present day the promise of work in this field was never brighter than now.

**Bibliography.**—Rosenmüller, 'Historia interpretationis librorum sacrorum in ecclesia Christiana' (5 vols., 1795-1814); Meyer, G. W., 'Geschichte der Schriftklärung' (5 vols., 1802-08); Ernesti, 'Institutio Interpretis Novi Testamenti' (5th ed., 1809); Marsh, 'Lectures on the Criticism and Interpretation of the Bible' (1842); Lücke, 'Grundriss der neutestamentlichen Hermeneutik' (1817); Schleiermacher, 'Hermeneutik und Kritik' (1838); Klausen, 'Hermeneutik. German translation from Danish' (1841); Immer, 'Hermeneutik des neuen Testaments' (1873); English translation (3d ed., 1890); Doedes, 'Manual of Hermeneutics' (translated from the Dutch, 1867); Davidson, Samuel, 'Sacred Hermeneutics' (1843); Fairbairn, 'Hermeneutical Manual' (1858); Cellérier, 'Manuel D' Herméneutique Biblique' (1852); Elliott and Harsha, 'Biblical Hermeneutics' (chiefly a translation of the foregoing, 1881); Lange, 'Grundriss der Biblischen Hermeneutik' (1878); Hofmann, 'Biblischen Hermeneutik' (1880); Farrar, 'History

of Interpretation' (1886); Terry, 'Biblical Hermeneutics' (3d ed., 1890), probably the best book on the subject in English.

D. A. HAYES,  
*Professor of New Testament Exegesis, Garrett  
Biblical Institute, Evanston, Ill.*

**EXELMANS**, ɛks-əl-mõng, Remy Joseph Isidore, COMTE, French soldier, Marshal of France; b. Bar-le-duc, 13 Nov. 1775; d. 22 July 1852. He entered the army in 1791, when only 16 years of age, and by 1799 had reached the rank of captain. He subsequently served with great distinction under Macdonald and Championnet in the campaign of Naples, and in 1801 was appointed to the staff of Murat as aide-de-camp. He was arrested in 1808 while serving with Murat in Spain, and sent to England, but after three years of confinement there effected his escape and in 1812 joined Napoleon in his Russian campaign. For brilliant conduct during this campaign he was appointed general of division by Napoleon but upon the emperor's fall was banished from France owing to his Napoleonic inclinations. He was, however, permitted to return in 1819 and seems to have been highly esteemed under every successive government. He was restored to the Chamber of Peers in 1831 by Louis Philippe and Louis Napoleon appointed him grand chancellor of the Legion of Honor, and on 11 March 1851 created him *Maréchal de France*. He was subsequently thrown from his horse which resulted in his death.

**EXEMPLARY NOVELS.** Second only in importance to 'Don Quixote' among the fictions of Cervantes are his tales, published in 1613 as 'Novelas Exemplares,' or 'Exemplary Novels.' Although the preface spoke of 13 stories, but 12 were first included, the 13th having evidently been withdrawn at the last moment. This was not printed until 1814, when Agustin Garcia Arrieta found it in manuscript among other matters of entertainment prepared from 1606 to 1610 for the delectation of an archbishop of Seville. Published at first in expurgated form, 'La Tia fingida,' or 'The Pretended Aunt,' it was soon presented in full, and now forms part of all modern editions of the 'Novelas Exemplares.'

The 13 stories were written at various times, one as early as 1605, since it is referred to in the first part of 'Don Quixote.' Cervantes, who had spent six years in Italy, sought to compete with Boccaccio in tale-telling, although expressly distinguishing his productions from the novelle of the 'Decameron' as being moral and instructive. Unlike his contemporaries, Cervantes drew less upon Italian sources than upon his own invention. He endeavored to reflect life as he had seen it and to avoid the sensationalism of Bandello and Cinthio. Such sensationalism appears only in 'La Fuerza de la sangre,' where, however, he carefully reconciles the ravished heroine to her lover. The exotic adventures so common in early fiction are reduced in this collection. Although an unreal London is shown in 'La Española Inglesa,' the heroine is a Spanish girl carried off by the English in their sack of Cadiz; and, although the island of Cyprus is the scene in 'El Amante liberal,' the story contains recollections of Cervantes' own experience among the *Mohamedans* of Algiers. If the setting of 'La

Señora Cornelia' is *Italián*, that of most of the tales is native, and in the best it is strongly localized. This is the case, above all, with 'Rinconete y Cortadillo,' a humorous picture of roguery among the professional thieves of Seville, organized in a band astutely governed. Inn life is smartly shown in 'La ilustre Fregona,' and life among the gullible students of Salamanca in 'La Tia fingida.' Humor and satire unite in 'El Casamiento engañoso,' with its account of the marriage of two knaves, each thinking to deceive the other, and, more admirably still, in 'El Coloquio de los perros,' with its dialogue between two dogs of Valladolid, one of them a canine Sancho Panza, who describes to the other his griefs in the service of various masters. Cervantes' imagination finds freest play in 'El Licenciado Vidriera,' whose hero suffers from the delusion that he is made of glass, and in 'La Gitanilla,' with its gypsy heroine who proves to be well born, after a noble youth for love of her has turned Bohemian. This story in particular has exerted wide influence. Preciosa's adventures being copied by Hugo in France and Longfellow in America, and dramatized by Montalván and Antonio de Solís in Spain, by Moeller and Wolff in Germany, and by Middleton and Rowley in England. Middleton, also, drew upon 'La Fuerza de la sangre,' as did Florian in his 'Léocadie,' and Fletcher in four plays borrowed from four tales of Cervantes—in 'Love's Pilgrimage' from 'Las dos doncellas' (used also by Rotrou), in 'The Fair Maid of the Inn' from 'La ilustre Fregona,' in 'The Chances' from 'La Señora Cornelia,' and in 'Rule a Wife and Have a Wife' from 'El Casamiento engañoso.' The last-named tale was dramatized, also, in England by Tobin; in Germany by Schröder; and in Denmark by Holberg. The 'Novelas Exemplares' were early translated into French, Italian, English and German. They are most fully discussed in the Spanish volume of Luis Orellana y Rincón, entitled 'Ensayo Critico sobre las Novelas Exemplares' (1890).

FRANK W. CHANDLER.

**EXEMPTION**, the right to be excused from rendering certain services, or retain property free from claims or taxation. Exemptions are established by positive law. For example, the laws designating certain classes of persons not liable to military service nor to jury duty. Such also are the laws exempting church and school properties from taxation. Exemption from debt claims is also granted in many cases; in distress for rent cases, the necessary household furniture, the tools of a workman, domestic animals and a limited supply of food are exempted from seizure under execution. For the various State exemptions it is necessary to consult the codes of the State in question. Consult Hubbell, 'Legal Directory for Lawyers and Business Men' (New York, annually).

**EXEQUATUR**, the document issued by the executive department of a government regarding the consul of another state after it has been formally notified of his appointment by the latter. The effect of the *exequatur* is to grant all the privileges, immunities and advantages to a consular officer in the country to which he has been appointed, with authority to discharge all the functions of his office and to constitute him the legitimate representative of

his state in the locality mentioned in the document. The following is the form of exequatur issued to principal consular officers of foreign countries by the government of the United States:

President of the United States of America

To all whom it may concern:

Satisfactory evidence having been exhibited to me that ..... has been appointed ..... of ..... at ..... I do hereby recognize him as such, and declare him free to exercise and enjoy such functions, powers, and privileges as are allowed to ..... by the Law of Nations (or "the ..... of the most favored Nations in the United States").

In testimony whereof, I have caused these letters to be made Patent, and the Seal of the United States to be hereunto affixed.

Given under my hand, at the City of Washington, the ..... day of ..... A.D. 19....., and of the independence of the United States of America the ..... President's signature.

SEAL

By the President

..... Secretary of State.

To subordinate consular officers an almost identical form is issued by the Secretary of State. When a state of war supervenes or even when diplomatic relations are broken between two states it is usual to cancel all exequaturs of consular officers of the country with which war has been declared or diplomatic relations broken. Consult Moore, John Basset, 'Digest of International Law' (1906); Stowell, E. C., 'Consular Cases and Opinions' (1909).

**EXERCISE, Physical.** The upbuilding of the muscular system of the body is of prime importance in preserving the health or the curing of disease, and whether by passive motion or volitional activity is now recognized as necessary to keep the various functions of the body in normal condition. Artificially devised methods have been brought into use, but regular daily out-of-doors exercise is preferable. Instruction in gymnastics is now given in many educational institutions and public schools, well-appointed gymnasiums being maintained for that purpose. In these gymnasiums outdoor sports are often practised, but the chief courses of exercise consist of a systematic use of dumb-bells, wands, Indian clubs, horizontal and parallel bars, chest-weights, swinging rings and other specialties. In many gymnasiums there are running tracks, baseball cages, swimming tanks, bowling alleys, etc. The chief outside sports are tennis, golfing, bicycling, baseball, football, rowing, walking, running, skating, swimming and the various forms of track athletics. See GYMNASIUM; HYGIENE; PHYSICAL TRAINING; EDUCATIONAL ATHLETICS, etc.

**EXERCISES, Spiritual.** See SPIRITUAL EXERCISES.

**EXETER, or Exon, Domesday.** See DOOMSDAY BOOK.

**EXETER, England,** city, seaport and county, parliamentary and municipal borough, in the county of Devon on the left bank of the Exe, 10 miles northwest from its outlet in the English Channel, on the Great Western and London and Southwestern railways and 171 miles by rail southwest of London. Though still presenting many indications of antiquity, the city can now boast of as handsome squares, terraces, streets and houses, all of modern erection, as any other in the kingdom. The principal object of interest is the cathedral, a noble

edifice founded in 1112. It is cruciform, 408 feet in length, and consists of a nave, with two side aisles, two short transepts formed out of two heavy Norman towers, each 130 feet in height; a choir of the same width as the nave and 128 feet in length; 10 chapels or oratories and a chapter-house. The west front, erected in the 14th century, is richly decorated, presenting one of the most picturesque façades of any building in Europe. The interior, restored by Sir Gilbert Scott in 1877, is magnificent. Its perfect symmetry and the grand unbroken line of vaulting are remarkable features. The episcopal throne dates from 1320. The Great Peter Bell weighs 12,500 pounds. The chapter-house contains a valuable library of manuscripts and early books. Other architectural antiquities are the remains of the castle of Rougemont, portions of the ancient city walls of Athelstan, Norman work in some of the churches and the noble guild-hall, tastefully restored. Among several fine modern churches Saint Michael's may be mentioned. Among the numerous educational establishments is the Exeter School, founded by the citizens in the time of Charles I, to which there are a number of free scholarships. It has 16 exhibitions to either of the universities of Oxford or Cambridge. The Exeter Diocesan Training College is also situated in the city. The charitable institutions of various kinds are numerous. The principal scientific and literary institutions are the Devon and Exeter Institution for the Promotion of Science, Literature and Arts, established in 1817, and possessing a valuable library; the Exeter Literary Society, established in 1835; and the Royal Albert Memorial College, Museum and Free Library. The college has over 1,000 students. Exeter is not an industrial town, its woolen manufacture, once one of the largest in England, being extinct; but it has iron foundries, manufactories of agricultural implements, paper mills, corn mills, tanneries, etc. Glove-making and lace-making are also carried on. By means of a canal, 5 miles in length and 15 feet in depth, vessels of 400 tons can reach the city, and there is a large floating basin. The Exe itself is not navigable to the city. Exeter is a place of remote antiquity, having been a British settlement long prior to the invasion of the Romans, by whom it was called *Isca Damnoniorum*. The city returns one member to Parliament. Pop. 48,664.

**EXETER, N. H., town,** one of the county-seats of Rockingham County, on the Squamscott River, the Boston and Maine Railroad, 26 miles east of Manchester and about 13 miles southwest of Portsmouth. Exeter was founded in 1638 by John Wheelwright, a Congregationalist clergyman, who was banished from Massachusetts. Massachusetts claimed control over the place until 1680. It was the capital of New Hampshire and the centre of military movements of the colony during the Revolution. The town is well known as the seat of the Phillips Exeter Academy (q.v.), established in 1781. The Robinson Female Academy is located in Exeter. The town contains a large public library and a number of manufacturing establishments, cotton mills, iron, brass and machinery factories; also manufactories of boxes, umbrellas, automobile tubes, asbestos and rubber novelties, casings and shoes. Pop. 4,897.

Consult Fassett, 'Colonial Life in New Hampshire'; Bell, 'History of the Town of Exeter' (Exeter 1888).

**EXETER**, Pa., borough of Luzerne County, 10 miles west of Scranton, on the Lehigh Valley Railroad. It has extensive agricultural, coal and lumber interests. Fort Wintermooth nearby is the principal object of interest. Pop. 3,537.

**EXETER BOOK**, or **CODEX EXONIENSIS**, a manuscript anthology of Anglo-Saxon poetry in the library of Exeter Cathedral. It was presented to the chapter by Leofric, first bishop of Exeter (1050-72), contains 246 pages of vellum, and is the extant original copy of some valuable remains of Anglo-Saxon literature. The text with a translation is to be found in Gollancz, 'The Exeter Book' (1895). Consult Tupper (ed.), 'Riddles of the Exeter Book' (1910).

**EXETER COLLEGE**, Oxford. This college, originally called Stapledon Hall, was founded in 1314 by Walter de Stapledon, bishop of Exeter, sometime Lord High Treasurer of England, who removed to this place his scholars from Hart Hall and made a foundation for a rector and 12 fellows. In 1404 Edmund Stafford, bishop of Exeter, added two fellowships and obtained leave to give the college its present name. In 1565 Sir William Petre, Secretary of State, added eight; in 1636 Charles I annexed one for the Channel Islands, and, lastly, Mrs. Shiers left certain rents in 1770, out of which two fellowships were founded. Under the authority of 17 and 18 Vict., cap. lxxxii, the fellowships (a number of which were appropriated to various archdeaconries or counties) were reduced from 25 to 15, and were thrown open; they are now 12 in number, three of them in suspense. From the revenues of suppressed fellowships over 20 scholarships were founded, eight of which (called Stapledon scholarships) are limited to persons born or educated in the diocese of Exeter, and one or more to persons born in any of the Channel Islands, or educated at Victoria College, Jersey, or Elizabeth College, Guernsey. In 1915-16 there were 32 scholarships and 181 undergraduates.

**EXETER HALL**, a large building formerly on the north side of the Strand, London, opened in 1831. It is capable of containing over 5,000 persons. In it the "May Meetings" of the several religious societies were held. It became in 1880 the property of the Young Men's Christian Association. In 1907 it was sold and demolished. "Exeter Hall" became by metonymy a term of opprobrium, to indicate the views of aggressive evangelists in their relation to public questions.

**EXPOLIATION**, a process of concentric or spheroidal weathering, whereby the rock tends to scale off in thin and often curved plates. It is usually explained as follows: Rock is a poor conductor of heat. During the day a boulder or ledge becomes heated for a few inches from the surface, while the interior remains unaffected. The consequent expansion causes the surface to spall. At night the surface cools quickly over an interior that may still be warm and the shrinkage again tends to make the surface scale off. In rocks made up of several minerals, like a granite, this process

is intensified by the fact that each different mineral has a different rate of expansion and hence tends to tear away from its neighboring minerals. The process is particularly characteristic of deserts, where there are great extremes of temperature.

**EXHAUSTIONS**, Method of. The ancient geometers employed the method of exhaustion for determining the areas of curves and for the solution of similar problems. The method consists in comparing the magnitude to be determined with rectilinear magnitudes; thus, the area of a curve with an area of a polygon constructed so as to be comparable with the curve in question. The use of the method is exemplified in the second proposition of 'Euclid's Twelfth Book.' The method was applied with all the rigorous logical exactness for which the Greek geometers are so famous. See **GEOMETRY**; **MATHEMATICS**.

**EXHIBITION**, Industrial. See **EXPOSITION**, INDUSTRIAL.

**EXILARCH**. The title of an officer in Jewish communities in Persia. In 624 the Jews rendered the Mohammedans considerable assistance in their campaign and in consequence the exilarch was recognized as the chief of the Jews. His functions were civil and judicial. Later the gaon of Sora and the head of the College of Pumbedetha shared his authority, the gaon being of equal rank, and when the office of exilarch was vacant performed the duties of the office. The exilarch assumed all the pomp of a prince. His induction into office was attended with pomp and ceremony. The office was in existence for seven centuries and ceased with the death of Saadiah who was assassinated in 942. It was revived again for a few years about the middle of the 12th century.

**EXILE**, voluntary or involuntary prolonged absence from one's country; also, a person long absent from his country. Involuntary exile or expulsion for crime, particularly for murder and other serious offenses, can be traced back to a very ancient period. It was known among the early Greeks and was the penalty not only for murder but for offenses affecting the general interests, chiefly the former. Exile often took the form of expulsion, with death or some other penalty as the alternative, or of simple transportation, as to a foreign land. Sometimes confiscation of property was an added penalty. In Rome under the empire, exile or expulsion was known in two forms: *deportatio* and *relegatio*. The first was often punishment for political criminals, but later its use was extended. It involved banishment, generally to an island, with forfeiture of civic rights and usually of property. *Relegatio* was a much less severe form of punishment, involving no loss of civic rights by the offender.

The rights of aliens who are voluntary exiles in the country to which they flee after committing political or other crimes is usually fixed by treaty. Generally those guilty of political crimes only are not subject to extradition. They are, however, subject to the laws of the country in which they reside. See **ALIENS**; **CITIZENSHIP**.

Transportation for crime was abolished in England in 1857, but it still survives among some nations, as Russia, this country maintain-

ing penal settlements in Siberia. The tendency to-day, in keeping with advancing civilization, is toward its utter abolition.

**EXMOOR**, a wild and hilly district in the extreme southwest of Somersetshire, extending also into Devonshire, England. It was formerly a forest, but, with exception of a considerable portion lately cultivated, it is now mostly heath and marsh. It embraces ranges of hills of considerable elevation (the loftiest being Dunkerry Beacon, 1,707 feet), and in the time of the Druids was a favorite spot for the celebration of their religious rites. Red deer still exist here in a wild state. Good descriptions of Exmoor may be found in Blackmore's 'Lorna Doone,' and Sir Conan Doyle's 'Micah Clark.'

**EXMOUTH**, *ëks'müth*, **Edward Pellew**, Viscount, English naval officer: b. Dover, England, 19 April 1757; d. 23 Jan. 1833. He served as midshipman in the *Blonde* frigate during the American Revolution, and greatly distinguished himself at Lake Champlain. In 1808 he had attained the rank of vice-admiral, and in 1814 he was made Baron Exmouth. In 1816 he proceeded to Algiers in command of a combined fleet of English and Dutch ships to enforce the terms of a treaty which the dey had violated. He bombarded the city for seven hours and inflicted such immense damage that the dey consented to every demand. Twelve hundred Christian slaves were by this exploit restored to liberty. Lord Exmouth was raised to the dignity of a viscount for this service. He was commander-in-chief at Plymouth 1817-21.

**EXMOUTH**, England, seaport, market town in the county of Devon, on the English Channel at the entrance to the estuary of the Exe. It is one of the favorite resorts on the coast of Devon, for sea-bathing and, owing to its sheltered situation and salubrious climate, has risen into favor as a winter resort. The chief industry is fishing, and the shipping trade is considerable; the new docks are commodious. Exmouth was one of the principal ports of the country in the reign of Edward III; but subsequently it became a mere fishing hamlet. Late years it has increased steadily in population and trade. Pop. 11,962.

**EXNER**, **Karl**, Austrian physicist: b. Prague, 1842. He received his education at Vienna and Zürich and in 1885 was chosen president of the Chemico-Physical Society of Vienna and seven years later became lecturer at the University of Innsbruck and from 1894 to 1904 held the chair of mathematical physics there. He retired in 1904. He has written 'Ueber die Fraunhoferschen Ringe' (1877); 'Ueber das Funkeln der Sterne' (1881); 'Ueber Beugungserscheinungen' (1885); 'Ueber die polarisierende Wirkung der Lichtbeugung' (1892); 'Genesis der Erklärung des Scintillation' (1901).

**EXNER**, **Siegmund**, Austrian physiologist: b. Vienna, 1846. He was educated at the universities of Vienna and Heidelberg and in 1875 was named to the chair of physiology at the former institution. In 1891 he became a director of the Physiological Institute. For original researches on the physiology of the nervous system he was twice awarded a prize by the Vienna Academy of Sciences. He has

written 'Leitfaden bei der mikroskopischen Untersuchung tierischer Gewebe' (2d ed., 1878); 'Untersuchungen über die Lokalisation der Funktionen in der Grosshirnrinde des Menschen' (1881); 'Die Innervation des Kehlkopfes' (1884); 'Die Physiologie der facettierten Augen von Krebsen und Insekten' (1891); 'Entwurf zu einer physiologischen Erklärung der physischen Erscheinungen' (1894). With Gad he was joint editor of the *Centralblatt für Physiologie* after 1887.

**EXNER**, **Wilhelm Franz**, Austrian technical expert: b. Gänserndorf, 1840. He received his education at the Vienna Polytechnic Institute and in 1874 became industrial-school inspector in the Ministry of Commerce. He was one of the founders of the Vienna Industrial Museum in 1879 and became its first director. In 1882, 1885 and in 1891 he was elected to the Chamber of Deputies. He has published 'Das moderne Transportwesen im Dienste der Land- und Forstwirtschaft' (2d ed., 1880); 'Werkzeuge und Maschinen zur Holzbearbeitung' (1878-83); 'Die Hausindustrie Oesterreichs' (1890); 'Das K. K. Technologische Gewerbe-Museum in Wien im ersten vierteljahrhundert seines Bestandes' (1904).

**EXODUS**, *Book of*. The book of Exodus is the second book in the Old Testament; and, of course, occupies the same position in the collection known as the "Five Books of Moses" or the "Pentateuch," which constitutes the first division of the Hebrew Bible. Its Hebrew name is *W'eilleh shemôth*, "And these are the names," or, in abbreviated form, *shemôth*, "Names" after the opening words of the book. The designation *Exodus*, which means, *Coming out*, that is, from Egypt, originated with the early Greek translation known as the Septuagint, and is meant to be descriptive of the contents of the book.

**Contents.**—The book falls naturally into four divisions of unequal length: (1) Oppression of Israel in Egypt (i, 1-ii, 22); (2) Preparations for the departure (ii, 23-xii, 29); (3) Exodus and march to Mount Sinai (xii, 30-xix, 2); (4) Giving of the Law and building of the tabernacle (xix, 3-xl, 38). The closing chapters of the book of Genesis record how the Hebrew nomads, after living in Canaan for several generations, were driven by famine to Egypt, where they were assigned to a district in the eastern portion of the Delta. There they remained for many generations (i, 7). In the course of time a new dynasty ascended the throne of Egypt, under which a period of oppression set in, from which the Hebrews were delivered under the leadership of Moses. After some wanderings in the desert, the fugitives encamped at the foot of Mount Sinai, where a covenant was established between the local God Yahweh and Israel, a law was given for the purpose of regulating the life of the covenant people in harmony with the will of their God; and a tabernacle, in which the people or their representatives might meet with their God, was built.

**Composition.**—In its present form the book is a compilation of material taken from three originally separate sources, commonly designated by the letters J, E and P. (For proofs of this assertion and for the significance of the symbols see article PENTATEUCH). The P sec-

tions can easily be separated from the rest; to distinguish E from J is more difficult, especially after chapter iii. The J and E narratives were written first, and the combination of the two was made long before P was written. The two earlier documents contained a full account of all the important events connected with Israel's stay in Egypt and with the exodus, also at least a brief record of the journey from the Red Sea to Mount Sinai. There followed an account of the giving of the law, the rebellion of the people, Yahweh's anger, Moses' intercession and the divine response. The P account was written by one who shared the common postexilic conception that the age of Moses was the period during which Yahweh was nearer to Israel than at any subsequent time; consequently he introduced more of the miraculous in his history, and attempted to trace the beginning of the religious practices and institutions of his day to that unique period in Israel's history. The latter tendency manifests itself especially in the priestly sections xxv, 1-xxxv, 18 and chapters xxxv-xl. For an analysis of the book of Exodus according to the sources used in its compilation consult any modern Commentary on Exodus, or any Old Testament Introduction. The contents of each source are printed consecutively in Kent, C. F., 'The Student's Old Testament'; Carpenter and Battersby, 'The Hexateuch'; Brightman, E. S., 'The Sources of the Hexateuch.'

**Legal Sections.**—In addition to the historical material derived from the three sources indicated, Exodus contains three groups of laws, which at first existed independently but later were embodied in E or the combined JE. (1) The *Ten Words*, commonly called the *Decalogue*, xx, 1-17; found, with few variations, also in Deuteronomy v. In both cases some of the commandments are expanded by certain hortatory additions, but the original form can easily be restored. (2) A second *Decalogue*, xxxiv, 10-28; which bears a more primitive aspect than the other and lacks the ethical emphasis. Most scholars hold that the decalogue in xxxiv is earlier than that in xx; the latter is considered by many a compendium of the teaching of the 8th century prophets, while the other is generally assigned to the period of the Judges or of the early monarchy. (For a fuller discussion of the two decalogues and of their relation to each other consult Eiselen, F. C., 'The Books of the Pentateuch,' chap. xvii). (3) *The Book of the Covenant*, xx, 22-xxiii, 19. The laws in this code deal with a great variety of subjects, and it requires considerable adjustment to make any systematic arrangement possible. Originally the arrangement may have been on the principle of the decalogue, in the sense that it contained 10 separate decalogues, each containing two groups of five laws. Corresponding to the two divisions of the decalogue the Book of the Covenant may be divided into two groups of laws, each consisting of five decalogues. (1) Judgments, dealing with civil and criminal cases; (2) Religious and humane laws. The five decalogues of the first group are not difficult to reconstruct; of the second group only four exist, though traces of the fifth appear. The judgments deal with the following subjects: (1) The rights of slaves, xxi, 2-11; (2) Assaults, xxi, 12-27; (3) Domes-

tic animals, xxi, 28-36; xxiii, 1, 4; (4) Responsibility for property, xxii, 5-15; (5) Social purity, xxii, 16-20 plus Deut. xxii, 13-27. The religious and humane laws deal with: (1) Kindness, xxii, 2, 3, 6, 7, 21-27; xxiii, 4, 5; (2) Justice, xxiii, 1-3, 6-8; (3) Duties to God, xx, 23-26; xxii, 28-31; (4) Sacred seasons, xxiii, 10-19.

Many of the laws in the Book of the Covenant are strikingly similar to Babylonian laws, chiefly those found in the law code of Hammurapi (q.v.), king of Babylon about 2100 B.C. (Consult Johns, C. H. W., 'The Relation between the Laws of Babylonia and the Laws of the Hebrew People'). This similarity has an important bearing on the question of the date and origin of the Hebrew code. One widely accepted view is that the Book of the Covenant is essentially a collection of Mosaic decisions, expanded and modified to meet the needs of the Hebrews in Canaan during the period of the Judges or of the early monarchy. However, there is much to be said in favor of the view that it is a Canaanite production, based on the Babylonian legal system, and that it came to the Israelites from the Canaanites (Luckenbill, D. D., 'Israel's Origins' in *American Journal of Theology*, XXII, p. 44).

**The Song of Moses.**—This poem, in chapter xv, was originally independent of its present context. From verse 17 it is clear that the poem in its present form cannot be earlier than the reign of David or even that of Solomon (compare also verses 13 and 15). It is not improbable, however, that it is the expansion of a shorter poem composed at the time the events commemorated took place (compare verse 21).

**Bibliography.**—In addition to the discussions already mentioned the following works in English may be named: Bacon, B. W., 'Triple Tradition of the Exodus' (Hartford 1894); Bennett, W. H., 'Exodus' (New Century Bible, Edinburgh no date); Cornill, C. H., 'Introduction' (London 1907); Driver, S. R., 'Exodus' ('Cambridge Bible,' Cambridge 1911); and 'Introduction' (1891); new ed., (1910); Gray, G. B., 'Introduction' (New York 1903); McFadyen, J. E., 'Introduction' (New York 1905); McNeile, A. H., 'Exodus' ('Westminster Commentaries,' London 1908). Also articles on 'Exodus' in Hastings, 'Dictionary of the Bible' and in 'Encyclopædia Biblica.'

FREDERICK CARL EISELEN,  
Professor of Old Testament Interpretation,  
Garrett Biblical Institute.

**EXOLOGY**, the usage by which in many primitive races a man is forbidden to marry a woman of his own stock or tribe. See MARRIAGE; TRIBE.

**EXOGENOUS** (ëks-øj'é-nūs), **PLANTS**, an old and now disused name for dicotyledons. Monocotyledons were similarly known as endogenous plants, or endogens. See BOTANY.

**EXONERATION**, in a general sense, the discharging from some liability or obligation. In a limited sense it is now applied mostly to the right of a surety to call upon the principal debtor to pay the guaranteed debt and relieve the surety from his liability. Consult De Colyar, 'Treatise on the Law of Guarantees and of Principal and Surety' (London 1900); Redfield, 'Law and Practice of Surrogate's Courts'

(7th ed., New York 1910); Williams, 'Principles of the Law of Real Property' (22d ed., Toronto 1914).

**EXOPHTHALMIC GOITRE**, enlargement with turgescence of the thyroid gland, accompanied by protrusion of the eyeballs, breathlessness, palpitation and anæmia. Also called Basedow's (q.v.) or Graves' disease.

**EXORCISM**, the act of expelling evil spirits by adjuration. The word is of Greek origin, *exorkismos*, from the verb *exorkizo*, which in classic Greek means to put one on oath, but in the New Testament to drive out by adjuration. Demonic possession was a notion generally entertained by the Jews in the time of Christ; and that it was entertained by Jesus Christ and his apostles is as certain as any fact recorded in the Scripture. (Matt. xii, 27; Acts xix, 13). Hence, till modern times it was believed by all Christians, though now it is repudiated expressly or tacitly, or is explained in a naturalistic sense, or at least ignored by very many who profess belief in the gospels as a divine revelation and the very word of God. The Catholic Church, while it does not stand committed to the popular beliefs of the faithful upon this matter, nor to the views even of her most eminent doctors, except so far as she may have formally adopted them in her authoritative symbols, claims to possess and to exercise in these days no less than in apostolic times the power to expel evil spirits from the obsessed or possessed, and exorcism is formally pronounced prior to the administration of baptism and the blessings of chrism (or holy oil) and of holy water. One of the minor orders of clergy in the Catholic Church is that of the "exorcist," and the ritual of the Church to this day has an official formula of prayers and adjuration for driving out demons. Pope Innocent I (d. 417) forbade exorcists to exercise their ministry save with the express permission of the bishop, and that rule is still in force.

**EXORCIST**, the name of one of the minor orders of the clergy in the Roman Catholic Church. See **HOLY ORDERS**; **EXORCISM**.

**EXOSMOSIS**. See **OSMOSIS**.

**EXOSTEMMA**, a genus of American shrubs and trees of the natural order *Rubiaceæ*, several species of which yield barks sometimes used in medicine. Though closely related to the genus *Cinchona* (q.v.) which yields quinine, the species of this genus are lacking in similar alkaloids. Saint Lucia bark and Caribbee bark, obtained from West Indian species, are probably the best known.

**EXOSTOSIS**, a bony excrescence from the osseous structure. See **TUMOR**.

**EXOTERIC**. See **ESOTERIC**.

**EXOTIC**, an appellation applied to a foreign plant not acclimated or naturalized. It is implied that the exotic is more or less of a rare or tropical character and can be preserved only in greenhouses.

**EXPANSION**. See **AMERICAN EXPANSION POLICY**; **TERRITORIAL EXPANSION OF THE UNITED STATES**.

**EXPANSION**, in physics, is the increase in the bulk of bodies, in consequence of a rise in their temperature. This is one of the

most general effects of heat, being common to all forms of matter, whether solid, liquid or gaseous. Expansion of three kinds is recognized: (1) linear (2) superficial; and (3) cubical. The last only is applicable to liquids and gases, as they have no definite form. Most solids and liquids expand uniformly as their temperature increases, each substance having its own peculiar rate of expansion. This statement is true, however, only for usual temperatures. It has been found that as temperatures are increased beyond normal limits the rate of expansion also increases. The ratio of increase in bulk for each degree rise in temperature as referred to the original volume at a temperature of zero is called the coefficient of expansion. Solids expand equally in all directions, so that the coefficient of cubical expansion for solids is three times the linear coefficient. Liquids expand much more for the same rise in temperature than do solids, and gases still more proportionally. With gases, moreover, the bulk depends very largely upon the pressure acting upon it, gases being readily compressible. However, gases do not differ materially in their coefficients of expansion. It is found that under a constant pressure the co-efficient of cubical expansion for all gases is about 1/490. The expansion of liquids varies considerably, but, in general, the denser the fluid the less the expansion; thus water expands more than mercury, and alcohol more than water; and, commonly, the greater the heat the greater the expansion; but this is not universal, for there are cases in which expansion is produced, not by an increase, but by a diminution of temperature. Water furnishes us with the most remarkable instance of this kind. Its maximum of density corresponds with 39.2° F. This fact is of the utmost importance in the economy of nature. When the surface of rivers and lakes is cooled the upper or surface layer of water sinks and warmer water from below takes its place till the whole mass is cooled to 40°. After this the circulation ceases; the colder layer being less dense remains at the top until it freezes. The maximum density point of sea water is considerably lower than that of fresh water, and varies with the quantities of the salt contained in it. The expansion of water is about the same for any number of degrees above or below the maximum density point. Thus, if we heat water 5° above 39.2° it occupies the same bulk as it does when cooled down to 5° below 39.2°. The force with which water expands in the act of freezing is shown when glass bottles are filled with water and sealed; the glass is broken in pieces when the water freezes. A brass globe, whose cavity is an inch in diameter, may be burst by filling it with water and freezing it; and the force necessary for this effect is 27,720 pounds. The expansive force of freezing water is due to the tendency which water in solidifying is observed to have to arrange its particles so as to form prismatic crystals, crossing each other at angles of 60 degrees and 120 degrees. Various methods have been tried to ascertain the specific gravity of ice at 32°; that which succeeded best was to dilute alcohol with water till a mass of solid ice put into it remained in any part of the liquid without either sinking or rising. The specific gravity of such a liquid is 0.92, which, of course, is the

specific gravity of ice, supposing the specific gravity of water at 60° to be 1. This is an expansion much greater than water experiences even when heated to 212°, its boiling-point. We see from this that water at the instant of solidification receives a sudden and considerable augmentation of bulk. See HEAT.

The coefficients of expansion of some of the commoner solids and liquids on the Fahrenheit scale are approximately as follows:

Glass, 1/75,000; iron, 1/50,000; gold, 1/40,000; copper, 1/36,000; silver and brass, 1/33,000; tin, 1/31,000; lead and zinc, 1/23,000; mercury, 1/11,700; water, 1/3,870; ether, 1/2,570; chloroform, 1/1,150.

Economically the importance of expansion is very large, particularly in the temperate zone. Here the variation of natural temperatures between winter and summer is about 80°. In all buildings, bridges, concrete constructions, etc., expansion joints are inserted to take up the variation due to the changes in temperature. In instruments of precision this variation becomes of the utmost importance, requiring delicate adjustments, as in the compensating pendulum. See PENDULUM.

**EXPATRIATION**, the voluntary renunciation of the rights and liabilities of citizenship in one country, in order to become the citizen or subject of another. The right of a citizen of one country to renounce his allegiance in order to adopt another country as his own has and is still much disputed. It seems most reasonable that the mother country and not the individual should decide the question. In the early part of the 19th century the United States was almost the only nation that claimed for individuals the right of expatriation without the consent of the government of which they were citizens or subjects. The European nations, as a rule, maintained that the permission of the sovereign was necessary; and the enforcement by England of the claim was one of the causes of the War of 1812. The right of voluntary renunciation of allegiance to the United States by one of our citizens was unsettled, so far as legislation was concerned, till the Act of Congress of 27 July 1868 asserted that expatriation "is a natural and inherent right of all people," but the action of the Department of State had previously seemed practically to admit the right. The first formal recognition of this principle was secured in an expatriation treaty with the North German Confederation, signed 22 Feb. 1868. The position of Germans with regard to naturalization has been somewhat altered by the German law of 1913, which declares that "a person does not lose his nationality if, before acquiring a foreign nationality, he has applied for, and received, the written permission of the competent authority of his home State to retain his nationality." England first recognized the right of voluntary expatriation by act of Parliament in 1870, and immediately concluded an expatriation treaty with the United States. This act was amended in 1914 with the intention of making the status of naturalized citizens uniform throughout the Empire. All the leading nations of Europe now recognize the right, including, besides those mentioned, France, Austria, Russia, Italy and Spain.

The right of the individual to expatriate himself has always been a cardinal doctrine with

American statesmen. The whole subject of expatriation is regulated by the law of 2 March 1907. Under this statute an American citizen is assumed to have changed his citizenship when he becomes naturalized in any foreign state. When an individual who has been naturalized in the United States has resided for a period of two years in the foreign state from whence he came, or five years in any foreign state, he is presumed to have divested himself of his American citizenship. An American woman who marries a foreigner assumes the nationality of her husband. If a resident of the United States on the termination of the matrimonial bond, she may reassume her citizenship, or if in a foreign state, by registration within a twelve-month with the American consul. A foreign woman who acquires through marriage with an American citizenship in the United States retains her status if she continues to reside in the country. The problem of assimilation has in the United States assumed an aspect of extreme gravity since the outbreak of the Great European War. On questions growing out of the war there has been maintained a persistent agitation by the representatives of foreign governments, with the object of influencing American citizens of their respective races and through them stimulating loyalty to these foreign governments so as to influence American opinion on their behalf, to the grave endangerment of American neutrality. Pressure has been brought to bear on legislators and through them on the national administration. Unwarrantable interference with the internal concerns of the United States led to the dismissal of Dr. Dumba (q.v.), the Austrian Ambassador. See CITIZENSHIP IN THE UNITED STATES; ALIENS; NATURALIZATION.

**EXPECTATION**. See PSYCHOLOGY.

**EXPECTATION SUNDAY**, the Sunday before Whitsunday. Acts i, 4, Christ commanded the disciples "that they should not depart from Jerusalem, but wait for the promise of the Father." They waited till the day of Pentecost and the promise was fulfilled.

**EXPECTATION WEEK**, the week, or rather the nine days, which elapsed between the ascension of Jesus and the Pentecostal effusion of the Spirit, because during that interval the apostles and early Church waited in expectation that the promised Comforter would come.

**EXPECTORANT**, a remedy used to increase the amount of secretion of the lower respiratory tract—the trachea and bronchi. Such remedies act: (1) Through nervous influences, like those of ipecac, antimony, senega; or (2) they increase the amount of blood flowing around the bronchi; or else (3) they stimulate the mucous membranes of the bronchi as they are excreted. To this latter class potassium iodide, chloride of ammonium, the aromatic balsams and squills belong. They are useful in chronic stages of catarrhal bronchitis. See BRONCHITIS.

**EXPECTORATION**, technically termed sputum, is a physiological secretion, but when there is an excess of secretion of mucus in the bronchi and trachea, which is expelled by hawking or coughing, it becomes a diseased condition. Its examination and determination are essentials in the diagnosis of chest ailments. **Ex-**



cessive expectoration is found in bronchitis, in pneumonia, in tuberculosis, in gangrene of the lung and in influenza. In all of these conditions the sputum carries the germ of the disease and should be disinfected. Miscellaneous expectoration in the street and public places should be prohibited by law. To properly disinfect the sputum it should be received in a paper spit-cup or appropriate pocket-flask, and later destroyed. A mixture of carbohc acid, 1 to 25 of water, or of chlorinated lime, a teaspoonful to a pint of water, should be used in spittoons if these are essential. In cases of tuberculosis and influenza particularly, great care should be taken of the sputum and of all handkerchiefs, towels, napkins and other linen that come in contact with the patient. See DISINFECTION; INFLUENZA; TUBERCULOSIS.

**EX PEDE HERCULEM,** ([know] Hercules from his foot), a proverb meaning that from a part we may be enabled to test the whole structure of a thing. The proverb is founded on the story that Pythagoras determined the stature of Hercules on the basis that the Olympic stadium measured exactly 600 times the length of Hercules' foot. In proportion as this stadium exceeded others which were 600 times the length of a normal foot, so much larger was Hercules than the normal man. Kindred are the expressions, "Ab uno disce omnes," "From one (treacherous Greek) know the whole (race)" (Virgil, 'Æneid' II, 65-66), and "Ex ungue leonem," "(know) the lion from his claw."

**EXPEDITIONS TO LATIN AMERICA.** See DISCOVERIES OF AMERICA.

**EXPERIENCE MEETING,** a religious gathering whereat some of those present recount their spiritual experiences. Such meetings are common in the Methodist denomination and other sects hold such meetings at stated intervals.

**EXPERIMENT,** an operation designed to discover some truth, principle or effect, or to establish or illustrate it when discovered. It differs from observation in the fact that the phenomena observed are, to a greater or less extent, controlled by human agency. Experiment distinguishes the modern method of investigating nature and we owe to it the rapid strides made in chemistry, physics and other sciences.

**EXPERIMENT STATIONS.** See AGRICULTURAL EXPERIMENT STATIONS.

**EXPERIMENTAL PSYCHOLOGY.** See PSYCHOLOGICAL APPARATUS.

**EXPERT.** One having special knowledge or skill in a particular subject; a specialist; specifically, in law, one qualified to give expert testimony in a judicial proceeding. See EVIDENCE.

**EXPERT TESTIMONY.** A branch of the law of legal evidence which may be defined as testimony in the form of an opinion, based upon facts proved in an action by other witnesses, or upon facts assumed to have been proved, concerning matters involving scientific or technical knowledge.

The value of expert testimony was recognized in the Roman law and was incorporated in that system of jurisprudence. In the law of some continental countries the system has al-

ways been firmly established. Indeed, in those countries, all forms of opinion evidence was and still is freely accepted: the courts giving it such weight as it seems entitled.

In the very earliest period of the English law, however, expert testimony was unknown. At that time a jury was selected from among persons already possessing knowledge of the facts of the case to be tried. In other words, during the early development of English law, the witnesses composed the jury and their verdict was based upon the facts within their own knowledge, and no effort was made to assist them. Gradually, however, the practice of taking testimony in open court came into vogue, and it was later seen, in order that an impartial verdict might be rendered, that the jury should be composed of unbiased persons, whose minds were not hampered by conclusions theretofore formed.

As a general rule in the English common law, which is, with slight modifications, the law of the United States, testimony of opinions has never been admitted as evidence. Our courts require and allow testimony as to facts only, and consider it the province of the court and jury to draw conclusions and form opinions from the facts proved. An exception to this rule is found in expert testimony. Since a jury represents only the average intelligence of the community, cases were early encountered where it was difficult or impossible for the jury to reach a reasonable conclusion from the facts proved before them, and to obviate the defect in the trial system, the courts gradually brought to its assistance expert witnesses, to aid in correctly determining questions presented. At that stage expert testimony was confined almost entirely to that of physicians. Causes of death or effects of physical injuries were then and still are the most common questions with which juries must deal, and the determination of such issues is dependent largely upon the opinions of skilled physicians, familiar with the conditions, testifying as experts. In later years in England and in the United States, expert testimony has been availed of to assist juries in various other classes of cases. The theory of the courts in allowing such testimony is, that the jury, or where the action is tried without a jury, the trial judge, is not competent to draw its own conclusion from the facts proved, without the aid of such testimony. In that event witnesses possessing technical or peculiar knowledge upon the subject are allowed to give their opinions as evidence for the enlightenment of judge or jury.

Within the last few years, the practice of employing expert testimony has grown rapidly and has resulted in the creation of a class of witnesses who might be termed professional experts, and who command large fees for their services. This has conducted to a result which has brought about much criticism, adverse to the system, based largely upon the fact that the testimony of expert witnesses involving lengthy technical discussions is one if not the principal cause of the unreasonable length of modern trials; upon the further fact that the testimony of the modern expert, with its technicalities and extreme length, tends rather to obscure than to enlighten the minds of a jury; but principally upon the fact that such testimony has proved in a great many cases to be so par-

tisan as to be wholly unreliable. This criticism is not unmerited.

The creation of the class of so-called professional experts whose services demand large compensation has resulted in a condition where opposite opinions may be obtained in any number. Some of the recent prominent murder trials have hence afforded an interesting spectacle of arrays of experts with conflicting opinions retained by the respective parties, at great expense, whose examination and cross-examination has consumed days and even weeks, exhausting the patience of the judge, consuming the time of the courts, perplexing instead of clearing the issues, and weakening the confidence of the public in its system of justice.

Before the testimony of an expert witness is admitted, he must be qualified as an expert; in other words it must be shown by his own testimony that he has a knowledge derived from experience or study not possessed by the ordinary persons in regard to the particular subject to which he intends to testify. Whether or not the witness has proved himself an expert is determined by the trial judge in his discretion.

The method usually adopted to get the testimony of an expert witness before the jury, after his qualification, is through the form of a hypothetical question. A question is put to the witness by the counsel of the party calling him, the question containing in detail the facts which the counsel believes have been proved and the witness is asked his opinion upon the assumption that the facts assumed are true. Such hypothetical question is often of great length, containing, as it does, a statement of facts that may have required days to prove. After the question is answered by the expert, he is usually subjected to a long cross-examination by the opposing counsel to test his skill and knowledge and the correctness of his conclusion. That the ordinary jury places little weight upon the conclusions of an expert based upon the facts contained in a hypothetical question may be inferred from the fact that the counsel putting the question may assume facts which have not been proved to the satisfaction of the jury. Again the question is often so long and involved that its meaning is soon lost.

In other cases, however, where the witness has knowledge of the facts, the hypothetical question is not necessary. For instance, the opinion of an expert in handwriting may be given after his comparison of the disputed writing with an admitted sample of handwriting used as a standard of comparison; and the physician who has examined a physical injury, or the alienist who has examined a person claimed to be insane, may testify as to his opinion based upon the knowledge acquired by him through such examination without the medium of a hypothetical question.

The courts do not consider expert testimony of great importance, or in any case binding on the jury. It is allowed solely for the purpose of assisting the jury and the courts take occasion to instruct a jury to attach such weight to expert testimony as in their minds it seems entitled to or disregard it altogether if they deem fit so to do. Such an instruction will be upheld even if there is no conflict in the expert testimony introduced.

In spite of the just criticism to which the modern development of expert testimony has

been subjected, the doctrine has its uses and is necessary to our system of jurisprudence.

Thus, such testimony is absolutely indispensable to prove the custom in a trade; to prove the tensile strength of materials; the probable cost of buildings or works; the chemical composition of materials; the presence of disease and the cause and effects of disease or physical injury and the cause of death; the seaworthiness of vessels and other nautical matters; and to assist the jury in various other matters not within the knowledge of the average judge or jurymen.

Various remedies through legislation have been suggested to remedy the abuses to which expert testimony has been subjected, such as limiting the number of such witnesses to be called upon a trial; limiting the length of the testimony, forbidding an expert witness receiving any compensation beyond the ordinary fees of witnesses and even to the extent of forbidding expert testimony in some classes of cases, the most recent suggestion in connection with criminal cases being the creation of a board of experts retained and compensated solely by the State whose services may be invoked by either the people or the accused.

It may be suggested that the evil will, in time, work its own remedy through the agency of the courts without the aid of legislation. The judge presiding at the trial of an action has a wide discretion in allowing or disallowing the testimony of experts, and it may be said that a too liberal policy of allowing expert testimony without limit is largely the cause of the abuse.

HENRY M. EARLE,  
*Attorney, New York City.*

**EXPIATION, Day of.** See ATONEMENT.

**EXPLANATION.** An event is explained when it is exhibited as an instance of a law, or true universal proposition. For example, the fall of a raindrop is partly explained if it is regarded as an example of the tendency of water to fall to the earth, and it is still further explained if it is regarded as an example of the gravitational attraction which each body has for every other. The explanation becomes even more satisfactory if the velocity and course of the raindrop are found to conform to the mathematical formulæ concerning gravitational motion in a retarding medium. In other words, the function of physical explanation is to reduce the world of physics from an incoherent mass of particular, disconnected facts, to the far more manageable domain of a few reasonable simple laws, even though these laws go beyond the particular facts which form their basis. The ideals of explanation are the same everywhere, though but seldom can the perfection of physical explanation be attained. Even teleological explanation, or explanation, not by the causes of natural science, but by purposes, attempts to reduce what it regards as the complex of deeds of some agent to the performances of some more or less stable character—that is, of some character which acts in a more or less uniform manner.

The criteria of a good explanation are largely dependent on the particular field within which the explanation is made. There are certain general methods of explanation which

have been found especially adapted to the facts of physics, others with a peculiarly psychological field of usefulness, others again which serve best in the discussion of moral conduct. The good new explanation, though like every innovation, it must in some way conflict with established traditions, will almost invariably follow in a general way the explanatory traditions of its appropriate field. There is one kind of explanation, however, which is almost never of service. This is the explanation that goes back to some more or less occult force, principle or faculty. See INDUCTION.

**EXPLOITS RIVER**, a river of Newfoundland, rising in the southwest part of the island and flowing in a northeastern direction through Red Indian Lake and emptying into the Bay of Exploits after a course of 160 miles. Large steamers ascend it for about 11 miles and light draught vessels for over 100 miles. It almost divides the island into two equal parts.

**EXPLORATION IN AMERICA.** As the routes followed by explorers of North America were determined by its physical contour, a brief geographical survey is necessary to understand the progress of its exploration. Thus considered, the continent divides itself into four geographic provinces: the Atlantic coast region, the eastern mountains, the central region and the western mountains. The first embraces the coastal plain and Piedmont plateau lying east of the Appalachians; the second the Appalachian Mountains and their northern extension to the Gulf of Saint Lawrence; the third the whole Mississippi Basin, the Great Lake region and the Hudson Bay drainage. The last province is the great cordillera of western North America, which lies west of the Mississippi Basin and includes the Rocky Mountain system, Pacific Mountain system and the Great Basin region lying in between.

The Atlantic seaboard, which was the scene of the earliest exploration and settlement, is separated from the central region by the Appalachian barrier. Hence the Saint Lawrence, lying beyond the northern terminus of this barrier, is the only easterly flowing river which drains any part of the central province; and as in an unexplored wilderness watercourses naturally offer the easiest routes of travel, it was by its valley that explorers first penetrated the continent. A way through the barrier was found by following the Hudson and its westerly tributary, the Mohawk, which is connected with Lake Ontario by a lowland area.

The central province is covered by a network of waterways extending nearly two-thirds of the distance across the continent, from the inland margin of the Appalachians on the east to the front of the Rocky Mountains on the west. It is separated by low divides into three distinct drainage systems: the rivers emptying into the Gulf of Mexico through the Mississippi; the waters which feed the Saint Lawrence; and the rivers tributary to Hudson Bay.

The western mountain belt stretches northward from Mexico through the United States and Canada to the Arctic Ocean. Its southern section is interlaced by a series of rivers tributary in part to the Rio Grande, flowing into the Gulf of Mexico; and part to the Colorado River, flowing into the Gulf of California.

The easiest route across the continent lay

near the present northern boundary of the United States, where the head waters of the Missouri reach far into the western mountains, only 500 miles from the Pacific, and separated by but one divide from the Columbia River Basin, which leads directly to the Pacific. Geographically, then, the explorations of our country fall into four groups: (1) those along the Atlantic seaboard, made by colonists of various nationalities; (2) those along the Mississippi, made by the Spaniards from the south, the French from the north and pioneers breaking through the passes of the Appalachians from the the Atlantic seaboard; (3) those made by the Spaniards northward from the Mexican border; and (4) those of the western mountains, made by Americans and of comparatively recent date.

Though the Cabots discovered North America in 1497 and claimed it for England, it was Spain who first attempted its exploration. Ponce de Leon, who had sailed with Columbus on his second voyage and subsequently become governor of Porto Rico, set out in 1513 in search of the "Fountain of Youth." Sighting an unknown coast at lat. 30° 8', he named the land "Florida," and turning south explored both sides of the peninsula. When he attempted nine years later to plant a colony on these shores, he was driven off by Indians.

But Spanish interest was aroused. In 1519 Cortes achieved his infamous conquest of Mexico, and the fame of its wealth inspired others to seek the New World. Pánfilo de Narvaez obtained a grant to conquer and govern Florida, by which was meant all the rest of the continent, stretching indefinitely northward from the Gulf of Mexico. With 300 men he landed at Tampa Bay in 1528 and marched northward, suffering terrible hardships. Disappointed at not finding the gold they sought, they returned to the coast near Appalachee Bay and set out for Mexico in improvised boats, but were wrecked by the way. Of the whole party, Cabeza de Vaca and three others were the only survivors. For six years they wandered: up through Mississippi, across the Mississippi River near Memphis, along the Arkansas and Red rivers to New Mexico and Chihuahua; at last reaching Sinaloa on the Gulf of California, where they were found by Spaniards and taken to Mexico (1536).

Cabeza's written account of their experiences, published after his return to Spain, falsely attributed great wealth to Florida. So when Hernando de Soto, fresh from the conquests in South America, which had given him riches and fame, obtained permission to conquer Florida, many flocked to join him. He sailed in nine ships with 620 men, maintaining great display. Landing at Tampa Bay in 1539, the procession wandered westward, ill-treating the natives, for three years in pursuit of gold through the wilderness of the present Georgia, Alabama, Tennessee and Mississippi to the banks of the Mississippi River. They crossed above the Arkansas, penetrated westward until frightened back by the roving prairie tribes, and returned to the Mississippi, where De Soto died and was buried in its waters at the mouth of the Red River (1542). His followers under Moscoso built seven brigantines, descended to the Gulf and reached the Spanish settlement on

the river Panuco, 311 survivors all told. Thus it was De Soto who first attracted attention to the Mississippi. Alonso de Pineda had discovered its mouth in 1519, and named it "Espiritu Santo," and Cabeza de Vaca crossed it about 1530; but neither of them recognized its importance.

The fate of this expedition discouraged coastal explorations for a time. But the Spaniards in Mexico were already pushing their way up into the heart of the continent. In 1539 Marcos de Niza, a priest, penetrated New Mexico and came back with reports of the wealth of Cibola, a name which he applied to seven cities somewhere to the north. These were long supposed to be mythical, but have since been identified as the seven Zuni villages in New Mexico.

The tale led Vasquez de Coronado to set out in 1540. Part of his expedition he sent by water up the Gulf of California under Hernando d'Alarcon, who discovered the Colorado River and ascended it for 85 leagues. The other part he led overland in the direction of Cibola, which he found and conquered (about lat. 35°); and then on into Kansas to about lat. 40°.

The belt of country bounding Mexico on the north received the name "New Mexico" from Antonio Espejo, an explorer who started north in 1582 with Indian guides to the rescue of three missionaries who had been deserted the previous year. Following the Rio Grande del Norte, he came to Cibola and, after learning that the missionaries had been killed, continued to explore the region and returned by the river Pecos.

The colonizer of New Mexico was Juan de Oñate. He entered the country in 1597 with 130 families and founded the first capital, San Gabriel (second oldest town in the United States), near Santa Fé. In succeeding years he carried his explorations westward through Arizona, in 1604 following the Gila River to the Gulf of California. The following year he founded Santa Fé.

While this was going on in the interior, other nations were interested in the coast. It must be remembered that Columbus was in search of a western passage to Asia when he came upon America. But the idea did not die. A similar quest brought the Cabots to the shores of North America; and later, as the vast extent of the new country began to be realized, one explorer after another searched the coast for a water route by which to pierce the continent. When at last the waters of the Saint Lawrence were found to lead no farther than the Great Lakes, explorers still pushed westward along the tributaries of the Mississippi or attempted to round the continent on the north through the ice-blocked seas.

In 1524 Giovanni da Verrazzano, sent by Francis I of France, examined the shores from South Carolina to Newfoundland, and wrote to the king the first known description of them. He brought back a theory of an inland sea approaching the Atlantic coast about the middle of the continent; and it was to find this "Sea of Verrazzano," as a possible route to Asia, that the king sent Jacques Cartier in 1534 to the Gulf of Saint Lawrence (previously discovered by Jean Denys of Honfleur). In the course of three voyages he explored the Saint

Lawrence as far as Montreal, believing that he had found the western passage.

Cartier attempted to plant a colony near the site of Quebec; but for many years France's efforts in that line were doomed to failure. Equally unsuccessful were Jean Ribaut, who in 1562 brought over a band of Huguenot colonists to the site of Beaufort, S. C.; and René de Laudonnière, who founded Fort Caroline two years later at the mouth of the Saint John's River, Florida. In 1565 Pedro Menendez de Avilés came to colonize Florida for Spain, and massacred the inhabitants of Fort Caroline. Laudonnière escaped to France, but Ribaut (who had just arrived from his second voyage with reinforcements for the colony) was killed while attempting to escape along the coast.

Menendez was the first to establish Spanish rule firmly in Florida. He founded Saint Augustine (oldest town in the United States) in 1565, sent a mission to the Rappahannock in 1570, and explored Chesapeake Bay and the Potomac.

England sent out her first colonists to Jamestown, Va., in 1607. Among the number was Capt. John Smith, an indefatigable explorer of the neighboring rivers and Chesapeake Bay.

Another Englishman, Henry Hudson, sent out in 1609 by the Dutch East India Company, explored the coast from Nova Scotia to Chesapeake Bay, and then ascended the Hudson River to Albany. It was during the following year that, in the search for a northwest passage, he discovered the strait and bay that bear his name.

France first gained a foothold in North America through the efforts of Samuel de Champlain. The years 1603-07 he spent in exploring the Saint Lawrence and the shores of New England, making the first accurate map of that coast. After he founded Quebec in 1608, he became interested in inland exploration, which twice led him into the United States. In 1609 he set out with 11 men to aid the Hurons against the Iroquois, descended the Richelieu in canoes, portaging part of the way, and pushed on through Lake Champlain to about Crown Point; and again in 1615 he accompanied a great war party of Indians by way of the New York lakes into the heart of the Iroquois country, south of Lake Oneida.

From this time fur-traders and missionaries spread over the country bordering the Saint Lawrence and its tributaries, gradually approaching the Mississippi. The Spaniards had not followed up their discovery, failing to understand its importance. Nearly a century after De Soto's journey the French at the north began to have an interest in the Indian traditions regarding the "Great River." About 1635 a trader, Jean Nicolle, was sent to a tribe near the head of Green Bay, Wisconsin. From there he went with Indian guides up the Fox River, portaged to the Wisconsin and descended that until he came "near the sea," as he reported; probably mistaking the "Great Water" described by the Indians for the sea. By 1658 two other French traders, Radisson and Groseilliers, reached the head of Lake Superior and explored the surrounding country.

When these rumors of a great river to the west reached Frontenac, the governor of Canada, he sent Louis Joliet to explore it in company with Jacques Marquette, a Jesuit. Meeting at Saint Ignace, they set out with five

men and two canoes, skirted the north shore of Lake Michigan and Green Bay, and ascending the Fox River, were guided by Indians across the portage to the Wisconsin, down which they passed, reaching the Mississippi 17 June. For one month they floated down the great stream, noting the mouths of its tributaries as they passed, until they came to an Indian village opposite the mouth of the Arkansas. By this time they knew that the river emptied into the Gulf of Mexico, and supposing themselves nearer the mouth than they actually were, they turned back through fear of Spaniards, returning by way of the Illinois and the western shore of Lake Michigan, which they reached by portage. Two years later Marquette met his death while attempting to establish a mission on the Illinois. His work among the Indians was taken up by Father Claude Allouez, also a Jesuit, who established several missions and traversed much of the country around lakes Superior and Michigan between 1665 and 1680.

Already another explorer was searching for the Mississippi. Robert Cavalier de La Salle was one of those who had come to Canada in pursuit of the passage to China, and guessed that it lay by way of the Mississippi, which he supposed emptied into the Gulf of California. In 1669 he crossed from Lake Ontario to a branch of the Ohio, and followed that river as far as Louisville. The next year he reached the Illinois from the end of Lake Michigan and explored it for some distance. For years he went back and forth through the region and established trade with the western Indians. In 1680 he sent Louis Hennepin, another Jesuit, with two men down the Illinois to ascend the Mississippi. On the way they were taken prisoners by the Sioux and carried up the great river to the Falls of Saint Anthony, which Hennepin named. There they were joined by the famous trader Daniel Greysolon Du Lhut, who for two years had fearlessly explored the region around the end of Lake Superior and the head of the Mississippi. He had just come by way of the Saint Croix River from his fort on the site of Duluth and now joined Hennepin on his return journey by the Wisconsin.

At last, in 1682, La Salle attained his goal. With Henri de Tonty and a large party he reached the Mississippi from the foot of Lake Michigan by way of the Chicago and the Illinois, and descended to its mouth. On 9 April La Salle took possession in the name of King Louis of France and gave the name Louisiana to all territory drained by the Mississippi. After his return he sailed for France and obtained permission to transport colonists to the new province. He reached the Gulf of Mexico, but was unable to find the mouth of the river, and put in at Matagorda Bay. There he built Fort Saint Louis, and then started overland to find the Mississippi and reach Canada to obtain supplies for the colonists, but was murdered by one of his men near a fork of Trinity River, Texas.

Where La Salle had failed, Pierre Le Moyné d'Iberville was to succeed. In 1699 he entered the Gulf of Mexico and explored the region around the mouth of the Mississippi, leaving a colony at Biloxi, which was afterward transferred to Mobile. With him was one already known as an explorer of the northern region, Pierre Le Sueur. He in 1695 had discovered

and named the Saint Peter (the Minnesota) River and observed a quantity of green earth near it; and now, in the belief that it was copper, he led a party of men up the river to work it and establish a fort on the Blue Earth (Green) River.

Just at this time (1703) Baron La Hontan, a man who participated in many explorations in the north of the Valley, published an account of his wanderings which contains some valuable information with much that is false. He claimed to have discovered a river (La Rivière Longue) entering the Mississippi from the west near Lake Pepin and to have followed it to its source in a large lake at the foot of mountains, on the other side of which was another river which emptied into the Pacific. This figured on maps for years before it was found to be fictitious.

The right to "farm out" this great country of Louisiana was granted to Antoine Crozat in 1714 and agents were immediately dispatched to explore the tributaries of the Mississippi. Before the year was out St. Denis followed the Red River and crossed to the Rio Grande, where he came upon a Spanish mission and was imprisoned, sent to Mexico and ordered to return. La Harpe in 1719 pushed up the Red River and across to the Arkansas, reaching lat. 37° 21'. He established a post among the Indians, claimed all this country for France and defied the Spaniards in a letter to the Spanish governor. The exploration of the Missouri was attempted in 1719 by Du Tisné and followed up to six leagues above Grand River, at the peril of his life among hostile Indians, who attempted in vain to bar his passage.

In this southwestern section of the Valley French intrusion was resented by the Spaniards. Their claim to Texas rested on the exploration of its rivers by Francisco de Urdinola in 1575, and an expedition led across its borders by Hernando del Bisque in 1675. Farther west their control was assured by the work of missionaries. Father Kino, a Jesuit, had entered Arizona as early as 1658 and by 1679 had established five missions and become well acquainted with the country. On one of his expeditions he reached the mouth of the Colorado and discovered that Lower California was a peninsula, not an island, as was supposed.

With the expulsion of the Jesuits in 1767 the missions passed into the hands of the Franciscans, who inaugurated the era of Spanish exploration and settlement in California by a colony at San Diego in 1769. Years before pioneers from the East broke through the mountains and seized upon the country, these missionaries had permeated it and stamped their influence upon it.

Meanwhile the French at the north were every year sending traders and explorers into the interior. For some time they continued to use the routes followed by Marquette through Green Bay and by La Salle up the Chicago, but in 1716 they opened a new one by way of the Wabash and another in 1720 by way of the Miami. A dispute over boundaries arose between the English and the French. Governor Spotswood of Virginia urged upon the English the necessity of colonizing the Ohio Valley and in 1716 made his fantastic ride with the "Knights of the Golden Horseshoe" to see if a way through the mountains could be found. He crossed the Blue Ridge and the Shenandoah

Valley, but it was not until 1732 that the first settler, Joist Hite, entered the region.

Other efforts were being made to cross the mountains. When it was learned that the French were winning the allegiance of the Cherokees from the English, Sir Alexander Cuming, a Scotchman, set out in 1730 with a party from Charleston and made a circuit of 500 miles across the mountains, bringing back several Indians in token of renewed faith. In 1736 Col. William Mayo and a party of surveyors followed the Potomac to its springs and discovered a portage to waters flowing into the Monongahela. Another route was opened to the Kanawha, an affluent of the Ohio, in 1744 by Col. James Wood, a well-known frontiersman and explorer. Dr. Thomas Walker in 1748 led an expedition across the Virginia mountains, named Cumberland Gap and River and made a circuit through West Virginia.

As the country became better known public interest awakened and in 1748 a number of Virginians formed themselves into the "Ohio Company" for the purpose of colonizing the Ohio Valley. To anticipate them, the governor of Montreal dispatched Bienville de Céleron down the Ohio to bury at the mouths of its tributaries plates inscribed with the declaration that all territory drained by those waters belonged to France. In spite of this, the Ohio Company sent out Walker in 1750 to survey lands for settlement. He explored Kentucky and built the first house in the region now comprised in that State. Christopher Gist was also sent to explore routes to the north, select lands for settlement and investigate the Indian tribes. He made a circuit of 1,200 miles north to the Scioto and Miami and then south of the Ohio, visiting all the Ohio tribes and returning by way of the Licking, Kentucky and Roanoke rivers. On a second mission in 1751, he discovered a new gap from the Potomac to the Monongahela and explored the Kanawha.

The next year Gist acted as guide to George Washington when he went as emissary from the governor of Virginia to the French fort at the head of the Ohio to protest against the French occupation of the valley. His mission was fruitless, but he brought back a map of his route: up the Potomac, across the divide and along the Monongahela and Allegeny to the French fort near Lake Erie.

A most prominent figure in English exploration was George Croghan. Sent out by Pennsylvania in 1750 with the half-breed Montour to win over the Indians through the Ohio Valley to the English, he went far and wide, from tribe to tribe, attaining an influence over the Indians which was of invaluable service to the English during the French and Indian War. When peace was declared he was delegated to prepare the Indians for English occupation. Starting from Pittsburgh, he followed the Ohio, Wabash and Maumee to Detroit and reported that the way was open; whereupon the English troops, under Capt. Thomas Stirling, advanced to Fort Chartres and took possession of the country east of the Mississippi.

And now, with English control assured, settlement spread rapidly beyond the Appalachians. Much of the preliminary exploration was made by hunters, trappers and traders too numerous to mention, were they known. North of the Ohio the country was first settled by Moravian

missionaries. Among the southern pioneers, James Smith followed the Kentucky and Tennessee rivers in 1766 and John Finlay explored northern Kentucky in 1767; but most prominent was Daniel Boone. His first venture was made in 1769, when he crossed the Cumberland Gap with James Robertson and spent two years exploring eastern Kentucky and Tennessee. Subsequently these two men took a prominent part in the settlement of this region.

With the advent of the American Revolution exploration received a check; but the expeditions of troops led by George Rodgers Clark into the Ohio Basin 1778-79 and by Gen. John Sullivan into western New York were not without geographical value. And in the Indian wars which followed (1790-94) the American expeditions under Harmar, Clark, St. Clair and Wayne added to knowledge of the Ohio Valley.

During the 17th and 18th centuries, while exploration and settlement had been pushed westward from the Atlantic seaboard over halfway across the continent, the Pacific coast was almost unknown. Balboa had discovered the Pacific at the Isthmus of Panama in 1513 and Cortes had sent several expeditions to the west coast of Mexico (1522-24). The first white man to reach the coast of California was the Spaniard Juan Cabrillo, who in 1542 traced it north as far as Monterey; and after his death the following year his pilot continued to Cape Mendocino. In 1576 the English seaman Drake reached lat. 43° in his coastal exploration. To the north the coast was unknown until Vitus Bering (1741), commanding a Russian expedition, visited it in lat. 60°. His voyage was followed by a swarm of Russian fur-traders, who, following the chain of Aleutian Islands during the latter part of the 18th century, gradually worked their way eastward and eventually reached the mainland of what is now Alaska.

In 1778 came Capt. James Cook, the famous English navigator, surveying the coast from Vancouver Island to the Arctic Ocean in his search for a northeast passage. When the published account of this voyage called attention to the rich fur-trade in the northwest, Americans were among the first to take advantage of it. In 1789 Capt. Robert Gray, of Boston, in the ship *Columbia*, cruised around the Horn and visited the northwest coast, carried a cargo of furs to China and returned to Boston by way of the Cape of Good Hope. Thus was the American flag first carried around the world. On a second voyage in 1792 he discovered and explored the lower reaches of the Columbia River. This all-important achievement, besides disclosing an easy route from the western mountains to the sea — thus paving the way for transcontinental exploration — formed the chief basis of our territorial claim to Oregon. When George Vancouver, who was exploring the west coast with two British vessels (1792), learned of the Columbia River through Gray, he sent a boat expedition to investigate it. Afterward he continued northward to extend Cook's explorations on the coast of Alaska and British Columbia.

As yet none had succeeded in finding an overland route to the Pacific north of Mexico. Cabeza de Vaca, in his transcontinental wanderings, had turned to the south when he reached the mountains. A Canadian, Varennes de la

Vérendrye, spent many years (1731-49) in the search for a route; at his own expense, for his government refused to back him. With his sons he made extensive explorations west of Hudson Bay, in the course of which he discovered (1731) the Red River and Lake Winnipeg, and his son Pierre penetrated to the forks of the Saskatchewan River (1739). In 1742 the two sons made a perilous journey to the southwest, across the Missouri and on to the Big Horn Mountains.

In the struggle for the Ohio Valley the western route was forgotten for a time. But when that contest was settled the quest was renewed by Jonathan Carver of Connecticut. In 1766 he made his way westward by canoe through the Great Lakes and by Marquette's route to the Mississippi, which he ascended to the Falls of Saint Anthony. He explored the Minnesota River, spent a winter among the Sioux and in 1767 returned by ascending the Chippewa River and reaching Lake Superior waters by portage. While his journey added little to geographical knowledge, yet it served to awaken interest and led Richard Whitworth to join Carver in planning a transcontinental expedition, which was unfortunately prevented by the outbreak of the Revolution.

Meanwhile the English fur-trading companies, through the journeys of their agents, had contributed much to geographical knowledge, not only of Canada but of the United States. The Hudson Bay Company, since it obtained its charter in 1670 and established its first post (Fort Rupert) on the great bay from which it took its name, had, in spite of French interference, extended along the shores of the bay and its tributaries. After the English conquest of Canada in 1763 it had a clear field until the appearance in 1783 of a rival "Northwestern Company," made up of Canadian merchants, which operated by the direct route from Montreal to the Great Lakes and rapidly pushed its control throughout the north and west. Its influence was extended to the west coast by Alexander Mackenzie in a journey (1792-93) from Lake Athabasca up the Peace River and across the Rocky Mountains, the head waters of the Fraser River and the Coast Range to the coast of British Columbia in the latitude of Queen Charlotte Sound. This was the first time the continent was crossed north of Mexico.

Thomas Jefferson in 1803 induced Congress to make an appropriation for the expenses of a transcontinental exploring expedition, a project that he had entertained for some 20 years. Nominally, Capt. Meriwether Lewis was leader of the party, with Lieut. (generally known as Capt.) William Clark second in command; but in point of fact all action was taken jointly and the expedition is always known as that of Lewis and Clark. While preparations were under way the purchase of the territory of Louisiana from France gave additional importance to the enterprise. Lewis and Clark, with 43 men, left Saint Louis, then a frontier trading-post, in three large boats, pushed their way up the Missouri and built a fort at the Mandan Village, about 50 miles above the present town of Bismarck, N. D. From this point some of the party were sent back and in the spring of 1805 the rest continued their voyage up the Missouri with 32 men. At the falls the heavy boats were left and canoes were constructed to continue the ascent of the

river. Near the head of what they named the Jefferson (the western fork of the Missouri) they cached their canoes and with horses secured from the Indians crossed the Rocky Mountains to the Columbia, which they descended to the mouth, reaching the Pacific in November 1805. After wintering here the party retraced their steps to the east side of the Rocky Mountains and there separated; Lewis following the Missouri while Clark traced the course of the Yellowstone. At the junction the reunited forces continued their rapid down-stream journey, reaching Saint Lewis in September 1806. This was not only the most notable exploration ever undertaken by the United States government, but its complete success led to the many others which have followed up to the present day.

The head waters of the Mississippi were explored by Lieut. Zebulon Montgomery Pike, who ascended the river with a party of 20 soldiers in 1805. He reached Leach Lake drainage system and found the region already occupied by the agents of the Northwestern Company. Upon his return in 1806 Pike set out again with 23 men, with the idea of winning the allegiance of the Indians from the Spaniards and establishing an American claim to the region which had long been in dispute between the French and Spaniards. He ascended the Osage River in boats and crossed overland with horses to the Pawnee villages, where he took up the trail of the Spaniard Malgares, who in the previous year had made an excursion into this region from Mexico at the head of several hundred troops. At the Arkansas Pike detailed Lieut. James Wilkinson to explore that stream to the Mississippi and continued west with the larger section of the party, arriving in November at that high peak of the Rockies which now bears his name. During the winter, after terrible suffering from cold and hunger, he reached the Rio Grande. The Spanish authorities sent out a large force to capture the little band of explorers and they were conducted back through what is now known as Texas.

The roving fur-traders were quick to penetrate the regions pioneered by Lewis and Clark and Pike. During the years 1806-09 they extended their excursions well into the Rocky Mountains from the east. In Canada the Northwestern Company, ever active, pushed its outposts westward; and in 1808 one of its agents, Simon Fraser, reached the Pacific at the mouth of the Fraser River.

In 1810 John Jacob Astor, a New York fur-trader, organized a company for the purpose of exploiting the trade on the Pacific slope. A vessel was dispatched to the mouth of the Columbia River to establish a post and an expedition sent overland to follow the Lewis and Clark route. This was the second party to cross the United States to the Pacific. Numbering three boats and 60 men under the leadership of one of the partners, Wilson Price Hunt, it left Saint Louis in the late summer of 1810 and pushed its way up the Missouri about 450 miles. Here the party wintered and in the spring continued by boat to the big bend of the Missouri; then with horses purchased from the Sioux proceeded overland in a southwesterly direction, crossed the Rockies near the head of the Big Horn River and followed the Snake River Valley to the Columbia. With only a fraction of his large party and after the most

terrible suffering, Hunt reached the mouth of the Columbia in February 1812, and found Astoria, the post established by the party sent by sea. The American company was only just in time; the previous year David Thompson of the Northwestern Company had portaged across the Rockies from the Saskatchewan to the head waters of the Columbia and followed it to the Pacific, where, much to his disgust, he found the Americans already in possession.

In 1812 David Stuart, with a small party, started eastward from Astoria to make the difficult and hazardous journey to Saint Louis. He chose a route to the head waters of the Snake, across the divide to the Green River, a tributary of the Colorado, and across a second divide to the Platte, which he followed to its junction with the Missouri and continued down stream to Saint Louis, arriving in April 1813, after a journey full of peril and hardship.

In 1814 Astoria passed into the hands of the Northwestern Company, which extended its trade over the entire Columbia River basin and established posts at various points. The eastern slope of the Rockies was occupied by American traders, with headquarters at Saint Louis and posts on the upper Missouri in the Green River Valley.

The government began to realize the importance of exploration. In the hope of discovering the sources of the Red River, a large expedition under Maj. Stephen H. Long left Pittsburgh on a small steamer in April 1819, wintered on the lower Missouri and during the following year made explorations and surveys in the country now included in Arkansas and Missouri. Long was sent again in 1828 to explore the head waters of the Mississippi, which he approached through the wilderness from the Miami River to Lake Michigan, thence to the junction of the Wisconsin and Mississippi and on to the Minnesota; a difficult route, but lying in a region which had been explored by French pioneers more than a century before.

Still the source of the Mississippi had not been discovered. The head water region, previously visited by Pike and long the stamping-ground of the fur-trader, had been again explored in 1820 by Gen. Lewis Cass, governor of Michigan, in company with Henry R. Schoolcraft. It was not until 1832 that the source was finally discovered in Lake Itasca by Schoolcraft and Lieut. J. Allen.

Capt. B. L. E. Bonneville, an officer of the United States army, in 1832 organized a party of trappers and hunters for the ostensible purpose of taking part in the fur-trade, but more to gratify his own ambition to explore the Far West. He left Fort Osage on the Missouri with 110 men, transporting his supplies by means of wagons, instead of using pack-animals, as all previous parties had done. Following Stuart's route of 20 years before along the valley of the Platte River, he crossed the mountains with his wagon-train and established a post at the head of the Green River. From this point as rendezvous his party scattered out in various directions, he himself exploring the Big Horn and Wind River mountains and extending one journey to the English trading-post on the Columbia. A party sent out by him visited Salt Lake and continued through to the Spanish settlement of Monterey on the Pacific.

During the years 1833-35 the Rev. Samuel Parker, a zealous missionary, made several hazardous journeys from the Mississippi waters to those of the Columbia. At this time the Hudson Bay Company, which had absorbed its rival, the Northwestern Company, controlled the entire Columbia River basin and claimed it for England, in spite of the protest of the few American settlers. In 1842 it came to the knowledge of the Americans that the English were making preparations to colonize the region and it was necessary that the authorities at Washington should be informed at once. For this purpose Dr. Marcus Whitman and A. L. Lovejoy set out in the dead of winter on a journey of 4,000 miles across the continent. They took a southerly route through New Mexico to the Arkansas, and Whitman reached Washington.

In 1841 Lieut. R. E. Johnson of the United States Exploring Expedition, commanded by Charles Wilkes, U. S. N., crossed the Cascade Mountains near Mount Rainier and, after making an extended journey in the Columbia River Valley, recrossed the Cascades to the coast. A detachment ascended the Willamette and crossed to the Sacramento Valley, which they followed to San Francisco.

With the exception of the Lewis and Clark expedition, the most important exploration of the century was done by Lieut. John C. Frémont, who had gained his first experience while assisting J. N. Nicollet, a French geodesist, employed by the United States government 1836-40, for making surveys in the upper Mississippi Basin. In 1842 Frémont, with 25 men, among whom was the famous scout, Kit Carson, made surveys of a region lying between the Missouri River and the Rocky Mountains along the valleys of the Kansas and Great Platte rivers. In 1843 he was instructed to carry his surveys to the Pacific Coast. With a party of 40 men he made his way westward from the junction of the Kansas and Missouri rivers to the head waters of the North Platte, crossed to Green River, and traversing a region long known through the explorations of Bonneville and others, crossed another divide and descended Bear River to Salt Lake, which he explored. From there he went westward to the Snake River, and on to the mouth of the Columbia. After renewing the supply of provisions, Frémont retraced his steps to the Dalles of the Columbia, then turned southward to Klamath Lake, and made a hazardous journey through the Sierras which brought him into California along the valley of the American River, an eastern branch of the Sacramento. Traveling southward, he once more crossed the Sierras in lat. 35°, and returned to Saint Louis across the Great Basin region and the Rockies. On his third journey Frémont crossed the Rockies from the head of the Arkansas to the Green River Valley, then continued westward around the southern end of Salt Lake across the Sierras, near where he previously traversed them and then turned northward along the Sacramento Valley and across the mountains to Klamath Lake. Here he was impelled to turn back by the news of the uprising in California, and converted his exploring party into a military expedition.

The southwest became better known through military operations during the Mexican War,



and after its close many expeditions were sent out by the government, under both military and civilian leadership, most of them, however, in regions already explored.

Public interest in the construction of a trans-continental railway led to five extensive expeditions during the years 1852-57: the first exploring along the 32d parallel; the second near the 35th; the third near the 38th and 39th; the fourth near the 41st and 42d; and the fifth near the 47th and 49th. Various military explorations and surveys were carried on west of the Mississippi up to the outbreak of the Civil War.

In 1869 Maj. J. W. Powell made a daring exploration of the Grand Cañon of the Colorado. With only a few men, in small boats, he followed the Green and Colorado rivers from Green River Station to the mouth of the Virgin River. In the next two years he extended this exploration in the Colorado basin under government auspices.

The Pacific Railroad surveys practically completed the purely exploratory work of the United States; subsequent investigation was directed to minor details. During the years 1867-79 this work was carried on by various organizations which were created for both geographic and geologic research. Four of them were of special note: "The Geological Exploration of the 40th Parallel," under Clarence King (King Survey); "United States Geographical and Geological Survey West of the 100th Meridian," under Capt. Geo. M. Wheeler, U. S. A. (Wheeler Survey); "United States Geological and Geographical Survey of Territories," under F. V. Hayden (Hayden Survey); "Geological and Geographical Survey of the Rocky Mountain Region," under J. W. Powell. In 1879 the United States Geological Survey was created for this purpose and the other organizations discontinued. The acquisition of Alaska in 1867 gave American explorers a new field. See ALASKAN EXPLORATIONS.

**EXPLOSION**, a sudden bursting, generally due to the rapid production of gaseous matter from solids or liquids. Thus the explosion of gunpowder is due to the sudden formation and expansion of gases into which the powder is converted by chemical agency. Explosions are often caused by the elastic force of steam confined in boilers, and by spontaneous combustion. See EXPLOSIVES.

**EXPLOSION CRATERS.** Although many of the great craters on volcanic peaks are due to explosion, the name is applied to holes not connected with lava outflows. Most of these holes are in plains and they are rimmed by a ridge of fragmental materials evidently blown out of the hole by an explosion. Craters of this class are the "maars" of the Rhine Valley, the craters of Eiffel, Auverne, Montecchio, Albani, Nemi, Astromi and Faifa in southern Europe, of Nassibe in Madagascar and Lonar, India. The latter, as described by Dr. Blandford, is a hole about a mile in diameter, 300 to 400 feet deep, in a great plain of old lava, similar to the rocks on the sides of the hole. The latter are bent up slightly. There are several notable explosion craters in Mexico, on the plateau near Orizaba Peak in Puebla and in Valle Santiago at Xico, Tacambaro, and on the northern part of Sonora. The Afton craters

in New Mexico, 31 miles northwest of El Paso, the crater of Zuñi Salt Lake, New Mexico, and the wonderful Crater Mound in east-central Arizona are also believed by some geologists to have been caused by the explosion of volcanic steam. As to the competency of this agent to cause a crater there are some notable illustrations in historic time, notably the great Bandai Sai eruption in Japan in 1888 which made a vast crater on a mountain where there had been no volcanic activity for many centuries. It was not attended by lava flow. The eruption of Krakatoa in 1883 is another impressive instance. Consult Darton, N. H., 'Explosion Craters' (*Science Monthly*, November 1916).

N. H. DARTON.

**EXPLOSION ENGINE.** See INTERNAL COMBUSTION ENGINE.

**EXPLOSIVE GELATINE**, blasting gelatine or gum dynamite, an explosive material resembling wine jelly in appearance. It was invented by Nobel in 1878, and consists of soluble cellulose nitrate dissolved in nitroglycerin. Originally, the solution was effected by warming the nitroglycerin and adding the perfectly dry soluble cellulose nitrate, called nitro-cotton, little by little, with stirring, whereby the nitroglycerin was made to dissolve from 4 to 10 per cent of the nitro-cotton: Then the solution was effected by the aid of a solvent like acetone, which was afterward evaporated off. All of these processes of manufacture were dangerous. In 1889, Lundholm and Sayer discovered that if the nitroglycerin and nitro-cotton are mixed with warm water and stirred up by compressed air, gelatinization sets in, and may be completed by pressing out the water and working the mass in malaxating machines. Explosive gelatine is a gelatinous mass, looking something like new honey in color, and varying in consistency from a tough leather-like material to a soft jelly, in accordance with a variety of circumstances, such as the quantity and chemical composition of the nitro-cotton used, and the methods of manufacture. In general, the thinner the gelatine, the more sensitive it is to detonation; but, on the other hand, a thin gelatine is subject to liquefaction and possibly also to exudation, which would make it dangerous in storage, transportation and use. Specially strong detonators are required to explode blasting gelatine; or ordinary detonators may be used with primers of dynamite or gunpowder: In order that detonation should be transmitted through a mass of explosive gelatine it must be confined; for, unlike dynamite, a train of it cannot be exploded in the open, except by means of an extremely powerful initial detonation. The sensitiveness of the material is still further diminished by the solution in it of camphor, or other substances rich in carbon and hydrogen, like benzene or nitro-benzene. While dynamite and nitroglycerin are much less liable to be exploded by a blow when frozen, the reverse is true of frozen explosive gelatine. Though while in the unfrozen condition explosive gelatine is less sensitive to shock or blows than either nitroglycerin or nitrocellulose, it is, when exploded, a more powerful explosive than either of them. This is due to the fact that when nitroglycerin is detonated, there are unused oxi-

dizing materials in the gaseous products; and when cellulose nitrate is detonated, there are unused combustible materials in the products. When, therefore, these bodies are mixed in the right proportions, the products will be those of complete combustion. Explosive gelatine has the advantage over dynamite in that it is practically unaffected by water and therefore can be stored in water. It is, on the whole, less liable to freeze than dynamite. It possesses an advantage over guncotton in being plastic and can, therefore, better adapt itself to the irregularities of the bore-holes in loading. The specific gravity of explosive gelatine is from 1.5 to 1.6. If heated slowly, beginning at 60° C., it will explode at 204° C. (399.2° F.). On rapid heating it explodes at 240° C. (464° F.). If ignited when frozen even small quantities may explode. Pure explosive gelatine is used for blasting in unusually tough rock or for blasting under water, or for military purposes. It is put up in cylindrical "sticks" in paper wrappers like dynamite. For general use in blasting it is too violent, and therefore "gelatine dynamites" are made by mixing this costly and powerful material with diluents. A great many different dopes are used, but a good example of a gelatine dynamite is "gelignite," which is made by mixing 65 per cent of explosive gelatine with 35 per cent of an explosive wood-pulp dope, giving a substance consisting of nitroglycerin 62.5 per cent, nitro-cotton 2.5 per cent, sodium nitrate 26.25 per cent, wood pulp 8.4 per cent, and sodium carbonate 0.35 per cent. "Forcite" is a similar modification of explosive gelatine containing 50 per cent of wood pulp.

**EXPLOSIVES** (from Lat. *explosus*, p.p. of *explodere*, to drive out, to drive out a player with clapping, to explode; from *ex*, out + *plaudere*, *plodere*, to clap, strike, applaud), are substances which easily react at comparatively low temperatures with the formation of a considerable volume of highly expanded gas, the evolution of heat and light and the production of sound. At ordinary temperatures they may be solid bodies like gunpowder or liquid like nitroglycerin or gaseous like fire damp mixtures. They may consist wholly of a single chemical compound like mercuric fulminate, or of mixtures of combustible substances with supporters of combustion or oxidizing agents like blasting powder, which is a mixture of charcoal, sulphur and sodium nitrate. Though the temperature is different for each explosive they can all be caused to explode if heated to the explosion temperature, which under given circumstances are for nitrogen chloride, 93° C.; mercuric fulminate, 152° C.; emmenseite, 165° C.; nitrostarch, 175° C.; dynamite and guncotton, each 180° C.; and blasting gelatine, 204° C.; nitroglycerin, 218° C.; blasting powder, 270° C.; picric powder, 273° C.; rifle powder, 275° C.; best sporting powder, 315° C.

**History.**—The inventor of gunpowder, the oldest of explosives, and the place where it originated, are not known. The invention has been ascribed by different authors to Marcus Græcus, Albertus Magnus, Roger Bacon and Berthold Schwarz; to the Arabians, whose works were largely used by Marcus Græcus in his writings; to the Hindus, because of certain passages occurring in the code of Gentoo laws prepared by Indian savants by order of

Warren Hastings in the 18th century; and to the Chinese because of certain statements made by Marco Polo. There seems to be little doubt that this confusion exists (1) because modern meanings have been given to words and phrases used in the old manuscripts; (2) because of the intentionally confusing methods employed by the writers of the Middle Ages; and (3) because gunpowder for use in guns was not the invention of any one person, but was really the result of a progressive development.

It is recorded that what moderns call "Greek fire," and the ancients called "naphtha," was employed in the defense of Constantinople in the 7th century and that these fiery compositions were propelled against the enemy by means of arrows from bows, or in hollow vessels of stone or iron thrown by war engines. Though consisting at first of pitch, rosin, sulphur and similar easily inflammable and highly combustible substances, it is easy to imagine that in the tentative development of these materials of war nitre was added to the combustible substances and that there was thus produced a deflagrating composition for use as bursting charges in bombs and grenades and for the manufacture of devices analogous to modern firecrackers and rockets with which to frighten and confuse their foes.

The supposition that gunpowder was known before it was applied for use in guns is supported by the older historians. All the components and mixtures for Greek fire similar to gunpowder were already known in the time of Hassan-al-Rammah (1290). From an exhaustive search of the literature Guttmann arrives at the conclusion "that gunpowder was gradually developed from Greek fire, and that it was known for years before cannons and guns were thought of. The use of purer materials in making it developed its propulsive power, and led to the subsequent invention of cannons and guns. The Arabians were the first to make gunpowder-like mixtures, probably about 1280 A.D., while the idea of utilizing their propulsive force, that is the invention of guns and cannons, belongs to the monk, Berthold Schwarz, of Freiburg, Saxony; the date of the latter invention being probably 1313 A.D." It is accepted as indisputable that gunpowder mills existed at Augsburg, Germany, 1340, and at Spandau, Germany, 1344, and that the English used gunpowder in guns at the battle of Crécy, 1346.

Though many improvements were made in the manufacture of gunpowder, such as in the preparation and purification of the raw materials from which it was produced; the methods of incorporation; and its granulation to adapt it to special uses, this substance remained unrivaled until the end of the 18th century, when the French chemist Berthollet proposed the substitution of potassium chlorate for the potassium nitrate and produced by this means a much stronger and quicker powder, but one which was also much more dangerous than gunpowder. Beginning with the discovery of mercuric fulminate by Howard, an English chemist, 1800, there was added to the achievements of the 19th century the discovery of nitrogen chloride by the French chemist Dulong, 1812; nitrostarch by Braconnot, 1832; guncotton by Schoenbein of Basel, Switzerland, 1845; nitroglycerin by Sobrero at Turin, Italy, 1846; the invention of blasting powder by L. DuPont of Wilmington,

Del., 1856; the discovery of diazo compounds by the German chemist, Griess, 1860; the invention of dynamite by A. Nobel of Sweden, 1866; smokeless sporting powder by Schultze of Potsdam, Germany, 1867; blasting gelatine by Nobel, 1878; military smokeless powder by Vieille of France, 1886; hard-grained smokeless sporting powder by Richard von Freeden of Walsrode, Germany, 1889; homogeneous smokeless powder composed of a single chemical substance in a state of chemical purity by Charles E. Munroe of Newport, R. I., 1890; and the discovery of triazoic acid by Curtius of Kiel, Germany, 1890, while in the meantime picric acid, which was discovered by Woulfe 1771, was shown to possess explosive properties and adapted for use in shell, it having been pointed out by Sprengel, 1873, that it contains a sufficient amount of available oxygen to render it, without the help of foreign oxidizers, a powerful explosive when fired with a detonator.

This growth has been coincident with the development of the chemical and physical sciences and has been the more rapid, the more completely experimental methods of research have been perfected and applied. In addition to those enumerated above this advance in the science and art of explosives has been chiefly due to the labors and intelligence of Hess, Lauer, Trauzl and von Lenk in Austria; Abel, Cundill, Debus, Dewar, Dixon, Dupré, Majendie and Noble in England; Berthelot, Chalon, Daniel, Desortiaux, Gay-Lussac, Lavoisier, Le Chatelier, Mallard, Maurouard, Roux, Sarrau, Turpin and Violette in France; Bunsen, Dittmar, Guttman, Liebig, Meyer, Schischkoff, Upmann, Will, von Förster and von Romocki in Germany; Abbot, Barnard, Craig, Emmens, Judson, Hill, Maxim, Mixer, Mowbray, Quinan, Rodman, Count Rumford and Woodbridge in the United States; Mendeléeff in Russia; Cronquist in Sweden and Hebler and Lunge in Switzerland. See the biographical sketches of Abel and Berthelot who were especially prominent in this science.

**Theory of Explosives.**—When wood or other combustible substances containing hydrogen and carbon are ignited in contact with air they burn, giving forth heat and light and are converted into water and carbon dioxide, which pass off as invisible and highly expanded gases. As the wood is subdivided so as to expose a continually increased surface to the air the rapidity of the combustion is increased until, when the wood is reduced to dust like sawdust and suspended in the air so as to be intimately mixed with it, the velocity of the combustion is so great and the evolution of the gases so rapid that the reaction becomes an explosive one and such a mixture of sawdust and air is an explosive. All incombustible combustible substances can, when finely divided and intimately mixed with air, form explosives and volatile liquids and gases are especially likely to do so. Many accidents have arisen from the ignition of mixtures of air with the dust of charcoal, coal, flour, malt, soap, starch, sugar, zinc, wood and other solids; with the vapors of alcohol, ether, gasoline and other naphthas, spirits of turpentine and other liquids, or gases like ethylene, coal gas, hydrogen and marsh gas since each of these substances, though in themselves non-explosive, form explosive mixtures with air if they be mixed with it in the right pro-

portions. The best proportions are those in which the volume of oxygen in the air present is just sufficient to convert all of the hydrogen in the combustible into water and all of the carbon into carbon dioxide, or, in other words, to produce complete combustion. Less violent explosions may occur when the proportion of air is greater or less than the "best proportion," the limit being fixed in each case by the character of the combustible substance, the quantity of the mixture, the temperature and pressure to which it is subjected and the manner in which it is ignited. Mixtures of these substances whose proportions are outside of these limits may be ignited and may burn, but do not explode.

If pure oxygen in the proper proportions be substituted for air in the above mixture the velocity of the reactions will be still greater, and the energy set free in unit of time and consequently the violence of the explosion will be greatly increased. Besides the proportions that determine the limits between explosion and combustion will be extended. Such mixtures if confined and out of contact with the air will still take fire and explode. Oxygen may be supplied either in the free state or in solid bodies which contain it and which give it up when heated to comparatively low temperatures. Among such solids are the nitrates of metallic radicles, like ammonium nitrate, potassium nitrate (India saltpetre), and sodium nitrate (Chile saltpetre); chlorates such as potassium chlorate; peroxides like sodium peroxide, and many others. If these solids be dried, finely divided, and intimately mixed with a combustible, in the right proportions, a solid explosive is produced. Often, as in the case of mixtures of charcoal and saltpetre the temperature to which they must be heated in order that combustion shall begin, called the point of ignition, is so high that they are difficult to ignite and in such cases a small portion of a substance like sulphur, which has a low point of ignition, is incorporated in the mixture.

Another method by which oxygen may be brought into intimate contact with combustible bodies so as to form an explosive is through the action of nitric acid upon them by which nitrogen and oxygen combined as  $\text{NO}_2$  is introduced into the molecule. Three cases present themselves. First, when the combustible body is a simple or mixed primary alcohol and the nitric acid reacts with the acidic hydrogen. Second, when the combustible substance is a hydrocarbon or its derivative and the nitric acid reacts with the hydrogen of the hydrocarbon or the hydrocarbon nucleus. Third, when the reaction leads to the union in the hydrocarbon of  $\text{NO}_2$  through the intervention of a nitrogen atom. The products of the first case are organic nitrates called also nitric esters. The products of the second case are nitro-substitution compounds. Those of the third are called nitroamines. Examples of the first case are ethyl nitrate from ethyl or grain alcohol, glycol nitrate from ethylene glycol, glyceryl nitrate (nitroglycerin) from glycerol (glycerin), mannitol nitrate from mannitol (mannite), starch nitrate (nitrostarch) from starch, and cellulose nitrates (gun cotton and pyroxylin) from cotton. Examples of the second case are mono and di nitro benzene from benzene, tri nitro phenol (picric acid) from

carbolic acid (phenol), nitrotoluenes from toluene, and nitro-naphthalenes from naphthalene. An example of the third is ethyl. These explosives differ markedly from mixtures like gunpowder, for, whereas in the mixtures the combustible substance and the oxidizing agents are in different masses, in the explosive compounds like nitroglycerin, they are both in the same molecule. Therefore in the latter the contact is more intimate and the reaction takes place with greater velocity.

In addition to the explosives of the characters described above is another class of chemical compounds, of which mercuric fulminate, silver amine (fulminating silver), acetylene, the azides and diazo benzene nitrate are notable examples, whose explosive properties are due to a phenomenon (namely, a molecular disruption), which is quite unlike that of combustion ascribed to those of the previous classes. This case of disruption arises from the fact that these substances are endothermic compounds, or in other words, that they absorb heat during their formation and are therefore reservoirs of energy.

**Classification of Explosives.**—Following the foregoing theories of their constitution and behavior, explosives may be classed as

(1) *Nitrate mixtures.*—Amide powder (charcoal, potassium nitrate, and ammonium nitrate); amidogene (bran or starch, charcoal, magnesium sulphate, potassium nitrate and sulphur); ammonal (metallic aluminum and ammonium nitrate); azotine (petroleum, charcoal, sodium nitrate and sulphur); blasting powder (charcoal, sodium nitrate and sulphur); carbazotone (bark or wood pulp, lampblack, ferrous sulphate, potassium nitrate and sulphur); Courteille's triumph safety powder (charcoal, peat, coal, oleaginous matters [animal or vegetable], metallic sulphates, sodium nitrate and sulphur); diorrexine (sawdust, sodium nitrate, potassium nitrate and sulphur); fractorite (rosin, dextrine, potassium dichromate, ammonium nitrate); gunpowder (charcoal, potassium nitrate and sulphur); haloxvline (charcoal, sawdust, potassium ferrocyanide and potassium nitrate); Himly's powder (hydrocarbons and potassium nitrate); Nordenfeldt and Meurling's powder (hydrocellulose, potassium nitrate and sulphur); pyrolithe (charcoal, sawdust, sodium carbonate or sulphate, potassium nitrate, sodium nitrate and sulphur); saxifragine (charcoal, barium nitrate and sulphur); schneiderite (mononitronaphthalene and ammonium nitrate).

(2) *Chlorate mixtures.*—Asphaline (hydrocarbons, potassium sulphate, potassium nitrate, potassium chlorate); Berthollet's powder (charcoal, potassium chlorate and sulphur); britainite (naphthalene, potassium nitrate, ammonium nitrate, potassium chlorate); Callow's powder (orpiment, potassium ferrocyanide and potassium chlorate); carlonites (naphthalene, or dinitrobenzene and other combustible substances with ammonium perchlorate); cheddite, (nitro body, oil and potassium chlorate); comet powder (rosin and potassium chlorate); cycene (cane sugar, paraffin oil or coal dust, potassium nitrate and potassium chlorate); Ehrhardt's powder (tannic acid, charcoal, rosin, potassium nitrate and potassium chlorate); Hahn's powder (charcoal, spermaceti, antimony sulphide and potassium chlorate); Himly and von

Trutschler-Falkenstein's powder (coal tar, potassium nitrate and potassium chlorate); Horsley's powder (nutgalls and potassium chlorate); Kellow and Short's safety powder (tarbark or sawdust, potassium nitrate, sodium nitrate, potassium chlorate and sulphur); Knaff's powder (ammonium ulmate, potassium nitrate, potassium chlorate and sulphur); Melland's paper powder (porous paper which has been soaked in a paste composed of starch, charcoal, potassium ferrocyanide, potassium chromate, potassium nitrate, potassium chlorate and water and dried); Oriental powder (gum gambier and potassium chlorate); Parone's explosive (carbon disulphide and potassium chlorate); Pertuiset's powder (sulphur and potassium chlorate); pyrodialites (mixtures of coal tar with chlorates or perchlorates and with or without nitrates, nitrosubstitution compounds, charcoal and oxidizing salts); pyronome (rye flour, charcoal, metallic antimony, sulphur potassium chromate and potassium chlorate); rosselite (asphalt oil and potassium chlorate); Siemen's powder (a solid hydrocarbon, potassium nitrate and potassium chlorate); thorite (cane sugar and potassium chlorate); tutonite (metallic sulphides, sulphur and potassium chlorate); and white powders of Augendre and Pohl (cane sugar, potassium ferrocyanide and potassium chlorate).

(3) *Oxidizing mixtures.*—These are mixtures of combustible substances with oxidizers other than the nitrates, chlorates or perchlorates. Among such bodies may be named sodium peroxide, potassium permanganate, potassium dichromate, liquid air and liquid nitrogen tetroxide. As examples we have mixtures of sodium thiosulphate with sodium peroxide; metallic aluminum with sodium peroxide; cotton wool with liquid air, and panclastite, which is a mixture of carbon disulphide with liquid nitrogen tetroxide.

(4) *Organic nitrates or nitric esters and mixtures containing them.*—Esters: Guncotton, which is a cellulose nitrate of high nitration and practically insoluble in a mixture of ether and alcohol at ordinary temperatures; nitrocellulose, a term applied to all cellulose nitrates; nitroelectrite (isomannitol nitrate); nitroerythrite (erythrol nitrate); nitroethyl (ethyl nitrate); nitroglucose, a nitrate produced from grape sugar; nitroglycerin, pyroglycerin or glonoin oil (glyceryl trinitrate); nitrolactose (nitrated sugar of milk); nitrolignin (nitrated wood); nitromannite (mannitol nitrate); nitromethyl (methyl nitrate); nitrostarch or xyloidine (starch nitrate); nitrosugar or nitrosaccharose, a nitrate produced from cane sugar; pyroxylin, collodion cotton, nitrocotton or pyrocellulose, are cellulose nitrates of medium nitration and practically completely soluble in a mixture of ether and alcohol at ordinary temperatures. In this class is also to be included the explosive mixtures into which these esters enter as essential components and of which the dynamites are conspicuous examples. These are classified, according to the nature of the *dope* or absorbent, into

A. *Dynamites with an inert base.*—Nobel's dynamite No. 1, giant powder No. 1; dynamite blanche de Paulilles; dynamite de Vonges; E. C. dynamite; S. 1, dynamite; Rutenberg's explosive; dynamite rouge, all consist of nitroglycerin with kieselguhr; Hill's powder (nitro-

glycerin with precipitated silica); Mowbray's mica powder (nitroglycerin with asbestos); Hercules powder (Extra No. 1); (magnesia powder, nitro-magnite; dynamagnite; fulgurite; nitroglycerin with magnesia alba); dynamite de boghead (nitroglycerin with ashes from Boghead coal); selenitic powder (nitroglycerin with plaster of Paris); Horsley's powder No. 1 (nitroglycerin, alum and magnesium sulphate); metalline nitroleum (nitroglycerin, red lead and plaster of Paris); renish dynamite (nitroglycerin, kieselguhr and naphthalene); dynamite noire (nitroglycerin, sand and coke); mataziette (nitroglycerin, sand, ochre, charcoal and resinous matter); porifera nitroleum (nitroglycerin, sponge or vegetable fibre and plaster of Paris); Burstenbender's explosive (nitroglycerin, spongy vegetable substances with glycocoll or chondrin); Morse's explosive (nitroglycerin with rosin); Borland's carbo-dynamite (nitroglycerin with charcoal from cork); white dynamite (nitroglycerin with lime-guhr); boritine (nitroglycerin, kieselguhr and boric acid); fluorine (nitroglycerin, kieselguhr and calcium fluoride).

**B. Dynamites with an active base.**—*a.* Consisting of nitroglycerin absorbed by a gunpowder like dope—Ammonia dynamite; ammonia krut; ammonia powder; Coad's explosive; Champion's powder; colonia powder; Dittmar's powder; dynamite No. 2; dynamite au charbon; dynamite d'ammoniaque; dynamite grieses de Paulilles; extra powder; Fowler's explosive; giant powder No. 2; Gotham's powder; Hercules powder; Horsley's powder No. 2; Judson's powder; Jupiter powder; lithofracteur; Monakay's explosive; miner's powder Co. dynamite; Neptune powder; potentia; petrolithe; sebastine; thunderbolt powder; Titan powder; virite powder; Vulcan powder.

*b.* Consisting of nitroglycerin absorbed by or gelatinized with a cellulose or ligno-cellulose nitrate—Blasting gelatine; cellulose dynamite; Clark's explosive; Dean's explosive; Dittmar's explosive; extra dynamite; explosive gelatine; glyoxyline; grisoutine; gum dynamite; nitrogelatine; paleine; Punshon's explosive; Schultze's dynamite; straw dynamite; Trauzl's dynamite.

*c.* Consisting of nitroglycerin or an explosive gelatine incorporated with wood pulp or sawdust and a nitrate, principally sodium nitrate. Such dynamites are styled lignin-dynamites—Ætna powder; amidogene; Atlas powder; Brain's powder; carbonite; diaspon; dualin; dynamite de Krummel; dynamite de Lanky; forcite; gelatine dynamite; gelignite; giant powder; Hecla powder; meganite; miner's friend powder; grisoutite; kadmite; petralithe; rendrock; rhexite; safety nitropowder; Schultze dynamite; stonite; stowite; vigorite.

*d.* Other dynamites.—Americanite (nitroglycerin and methyl alcohol); Castellano's powder (nitroglycerin, fibrous material, earth and nitrobenzine); cerberite (nitroglycerin, wood oil, nitrobenzine, wood pulp and sodium nitrate); Engle's powder (nitroglycerin, ammoniacal salts, saltpetre, pyroxyline, nitro-starch, nitromannite, nitrobenzine, and water glass); glukodine (nitroglycerin and nitrosaccharose); perunite or terrorite (nitroglycerin, nitromethyl, nitroethyl and pyroxylin);

thunder powder (nitroglycerin and nitroglucose).

*e.* Low freezing dynamites.—Ordinary dynamites freeze at temperatures prevailing in the northern and middle Atlantic states from October to May. When frozen they are difficult to detonate and are therefore not only inefficient but dangerous and particularly when being thawed. To overcome this defect nitro-substitution compounds such as some of the nitrotoluenes and, more recently, esters such as nitrated di- and polyglycerins are introduced as components of dynamite. These are styled *L. F. dynamites* and put upon the market with a designating term of this kind.

**C. Organic nitrate mixtures other than dynamites.**—Casteau's explosive (nitrodextrine and ammonium nitrate); Coopal's powders (resinous bodies, barium nitrate, and nitrocellulose); diflamyr (metallic nitrates and nitrocellulose); flammire (collodion cotton, ammonium sulphate and ammonium nitrate); grenée powder (paraffin; agar-agar, nitrocellulose, potassium nitrate, and barium nitrate); explosive P, (nitrocellulose and ammonium nitrate); potenite and tonite (guncotton and barium nitrate).

(5.) *Nitrosubstitution compounds and mixtures containing them.*—Compounds: Nitrobenzenes; nitrocresols; nitrocumenes; nitronaphthalenes; nitronaphthols; nitrophenols; nitroresorcinols; nitrotoluenes; picric acid or caroazotic acid (trinitrophenol); picramic acid; styphnic acid or oxypicric acid (nitroresorcinol); trinitrotoluene (T. N. T.); trotyl; tetranitraniline; tetranitronuthyl-aniline (tetryl, tetralite).

**A. Mixtures containing nitrosubstitution compounds.**—Abel's powder; ammonite; amvis; bellite; boritine; Borlinetto's powder; Boyd's powder; bronolithe; Brugere's powder; explosive A; explosive C; explosive N; cremonites; Du Bois-Raymond's powders; duplexite; ecrasite; emmensite; Faversham powders; Favier explosives; ferrifactor; Fontaine's powder; Gathhurst powder; gelbite; Geseric's powder; Girard's powder; hellhoffite; Hill's powder; Johnite; joveite; kinetute; lyddite; macarite; melinite; oxonite; plastrotyl; rack-rock; roburite; romite; securite; streeties; triplastite; Volney powders.

(6.) *Fulminates.*—Compounds: Copper and silver, acetylides; diazobenzine nitrate; fulminating gold (auramine); fulminating silver (argentamine); mercuric fulminate; mercuric triazotate; lead and nitrogen chloride (chloramide); nitrogen iodide (iodamide); silver fulminate; and triazoic acid, also called hydrazoic acid and azoimide.

In addition to these classes there are seven groups of explosives which have received such widespread notice as to merit especial mention here, though the members of each may all be and many of them are included in the classes given above. These groups are Sprengel explosives, safety or flameless explosives, permitted explosives, and smokeless powders, shell explosives and grenade and bomb explosives.

**Sprengel Explosives.**—These explosives were invented by Dr. Hermann Sprengel, 1873, and he advocated their use because of their safety, as they are non-explosive during manufacture, storage and transportation, but are very powerful explosives when prepared and de-

tonated. His plan was to employ mixtures of combustible and oxidizing substances, which should be kept separate until needed for use, the bodies to be employed in the compounding of the explosives being either all liquid or part liquid and part solid, for by taking advantage of the liquid state speedy and intimate mixing could be realized and the explosives could be compounded on the spot and at the time they were wanted for use. Among the oxidizing agents proposed were the nitrates and chlorates, which are solids, and nitric acid and nitrogen tetroxide, which are liquids. Among the combustible substances were the nitrosubstitution bodies, carbon disulphite and petroleum. A conspicuous example of a Sprengel explosive is rackarock, which was used in blowing up Flood Rock in Hell Gate, N. Y., and which may be made by pouring mononitrobenzine upon potassium chlorate crystals. Other examples are some forms of emmensite; explosive A; hellhoffite; oxonite; panclsite; and Parone's explosive.

**Safety or Flameless Explosives.**—These explosives are for use in fiery mines, particularly coal mines, where there is a chance of an accident arising through the ignition of the fire damp from the flame or incandescent particles given off by the explosive as the blast is fired. Among the earlier devices employed to prevent this was the mixing in the dope of the dynamite or with the powder of a quantity of washing soda, alum, Epsom salts or other salt containing a large amount of water of crystallization that would be set free when the mixture was fired. In 1883 Mallard and Le Chatelier discovered that when explosives were detonated unconfined in air containing 10 per cent of methane (marsh-gas), the fire damp could not be ignited if the temperature of detonation was below 2200° C., owing to the cooling of the gases due to their rapid expansion and to the retardation of the inflammation of the fire-damp. An investigation by the French Fire Damp Commission showed that, among others, certain salts of ammonia and especially ammonium nitrate, were capable of reducing the temperature of the gases produced by detonation very materially, the temperature of the gases from explosive gelatine being reduced from 3090° C., when detonated alone, to 1493° C., if detonated when mixed with 88 per cent of ammonium nitrate. In August 1890 the French government prohibited the use of black powder in fiery or dusty mines and permitted the use in them of explosives whose gases are not combustible and the detonation temperature of which does not exceed 1900° C., where blasting is to be done in the rock, nor 1500° C., where the work is to be done in the coal seam. Among the explosives designed to meet such conditions and styled abroad safety or flameless explosives are: Ammonite; amvis, aphisite; bellite; benedite; britainite; cambrite; carbonite; Casteau's explosives; dahmenite; Favier's explosive; fractorite; Geserick's powder; grisoutine; grisoutite; nitroferriite; progressite; roburite; securite; westphalite; wetterdynamite.

**Permissible Explosives** are those which have passed the tests by the United States Bureau of Mines and which have been placed by it on the Permissible List of Explosives for Use in Coal Mines, established in 1908. There were

137 explosives on the permissible list 15 April 1916 classified as "ammonium nitrate," "hydrated," "organic nitrate" and "nitroglycerin" explosives. Rules for testing and regulations for use of these explosives are supplied in free publications of this Bureau. By the use of these explosives safety in mining coal is increased.

**Smokeless Powders** are high powered propellents used as substitutes for gunpowder in firearms and cannon. They are formed of the highest grade of cellulose nitrate only, like indurite, or of the medium grade only, like pyrocellulose powder, or they may be mixtures of different grades together with metallic nitrates like the B. N. powders. Another class are mixtures of cellulose nitrates with nitroglycerin and a restrainer, like vaseline; ballistite, cordite and flite being examples of this kind. In robin-hood, gold dust, and gelbite, we have examples of such powders made from nitrosubstitution compounds and oxidizing agents. Other smokeless powders are amberite; Erackett's powder; cannonite; Curtis and Andre's powder; Du Pont powder; E. C. powder; fulgor; granulite; hornite; J. B. powder; kolfite; poudre J; poudre S; pyrocollodion; rifleite; Schultze powder and Walsrode powder.

**Shell Explosives.**—For charging armor piercing and other high explosives shell very stable, insensitive, detonating explosives are required. Nitroglycerin, dynamite, guncotton and explosive gelatin were tried but found too dangerous. Picric acid was known to be powerful and, when condensed by fusion, so insensitive that it could be safely fired from modern guns, but it was found difficult to detonate it when it was compressed in the shell. Turpin in France in 1886 solved the problem by causing a mercury fulminate detonator to act on pulverulent picric acid contained in a cavity in the compressed picric acid. For attack on warships shells are required that will pass through the armor and explode when on the inside. According to Marshall nitroaromatic explosives, such as picric acid, generally detonate on the face of the armor. This is accomplished by ammonium nitrate explosives. The first complete demonstration was made at the United States Naval Proving Ground, Indian Head, Md., in 1897 under Capt. W. T. Sampson, U. S. N., when a shell containing 8.25 pounds of Joveite (mononitronaphthalene, picric acid and ammonium nitrate) penetrated a sheet of the harveyized armor of the United States Steamship *Kentucky* 14.5 inches in thickness and burst on the other side of the plate. Compressed picric acid is known in France as melinite; in England as lyddite; Germany, granatfüllung 88; Italy, pertite; Japan, shimosite; Sweden, coronite; Spain, picrinite; and Austria, ecrasite. In many instances other substances are mixed with the picric acid. Thus in France to reduce the melting point and avoid the formation of cavities from crystallization or "piping" trinitrocresol is mixed with the picric acid. A mixture of 60 per cent trinitrocresol and 40 per cent picric acid is known as cresylite 60/40. It melts at 85° C., but at 65° is sufficiently plastic to permit of its being compressed into charges which, on cooling, are compact, amorphous and very homogeneous. In Austria ammonium cresylate is mixed with the picric acid. Since picric acid is corrosive, and

may, by action on the metal of its containers, produce dangerously sensitive compounds, and also because the supply of it is limited, trinitrotoluene has come to be largely used as the bursting charge for detonating shells. Schneiderite (mononitronaphthalene 10 per cent and ammonium nitrate 90 per cent) is used at Creusot for this purpose also. Macarite (T. N. T. and lead nitrate) is also used.

**Grenade and Bomb Explosives.** Ammonal, cheddite, compressed gun cotton, picric acid, smokeless powder, T. N. T., and tonite are used for charging hand grenades and bombs.

**Methods of Firing Explosives.**—Explosives may be made to explode by heating them to their explosion temperatures. This may be accomplished by a flame, a spark, an incandescent body, friction, percussion, concussion, pressure or chemical action, provided the resulting temperature is sufficiently high. Gunpowder was originally ignited in muskets, guns and boreholes by the application of a torch, a glowing tinder or a heated iron rod. Later muskets were fired by the sparks from a flint striking steel. Joseph Egg, an English gunmaker, 1815, invented percussion caps and to-day all fixed ammunition is fired by percussion primers, while the charges in very large guns are fired by friction primers or by electric primers. In firing blasts a train of powder was laid from the mine to a safe distance by which to convey the inflammation. Later quills, straws or paper or wooden tubes were used to hold the train and permit of the charge being tamped so as to secure the advantage which comes from confining an explosive. Bickford of Tuckingwall, England, 1831, invented the "running" or "tape" or "safety" fuse, in which a core of gunpowder is enclosed in a tube of jute yarn impregnated with a waterproof composition, and this is to-day largely used in firing blasts. Dr. Watson of England, 1745, succeeded in igniting gunpowder by means of electric sparks, and in 1749 a battery of 11 guns was fired by means of a frictional electric machine at Annapolis, Maryland. Dr. Robert Hare of Philadelphia, 1832, invented the method of firing gunpowder charges by means of the electric current, using low tension fuses, and he had for some time prior to this employed the voltaic battery, in eudiometrical experiments, for igniting explosive mixtures of gases. Sir Charles Wheatstone, 1856, introduced the magneto-exploder in blasting, and Moses G. Farmer of Newport, R. I., 1871, invented the dynamo-electric machine with which to generate the current and applied it to firing electric ignitors or detonators, and to-day great guns, military and naval mines, and torpedoes and many blasts, especially those in which several charges are to be fired simultaneously or where the blast is under water, are fired by this means.

It has long been known that when a notable quantity of a mixture of two volumes of hydrogen with one volume of oxygen is ignited at any point, the inflammation extends almost instantaneously throughout the mass and a most violent explosion ensues. This phenomenon is called detonation, and this mixture has long been known under the name of detonating gas. Certain chemical compounds such as nitrogen chloride, nitrogen iodide and mercuric fulminate undergo an almost instantaneous decomposition,

giving rise to violent explosive effects, if heated, struck or rubbed, and they are known as detonating explosives. At first guncotton, nitroglycerin and dynamite were fired by ignition, as gunpowder had been, but Nobel, 1866, discovered that if a quantity of mercuric fulminate was detonated in contact with nitroglycerin or dynamite they then underwent a detonating explosion also. E. O. Brown of the chemical department at Woolwich, England, 1868, discovered that not only could dry compressed military guncotton be detonated in this way, but that if the dry charge, called a primer, was in contact with wet guncotton, the latter was detonated also, even though it was saturated with or submerged under and in contact with water. There are then two kinds of explosion, namely, explosion by simple combustion and explosion by detonation. Explosives of the gunpowder class undergo only the first kind of explosion. Explosives of the nitric ester or nitrosubstitution classes undergo both kinds of explosions. Explosives of the fulminate class practically undergo only the second kind of explosion. A marked difference between the two kinds of explosion is found in the velocity with which the explosive reaction is propagated within the mass of the explosive. Thus in detonating gas, which can undergo both kinds of explosion, Bunsen found, when using very narrow tubes where only combustion could take place, that the velocity of the reaction was 34 metres per second, while Berthelot, using long and wide tubes in which detonation could take place, found that the velocity of the reaction was 2,810 metres per second. Experiments made by laying trains of the materials and firing them showed that while the velocity of combustion of gunpowder in the open air is but from 1.5 to 3.4 metres per second, the velocity of detonation of dynamite and of guncotton is about 6,000 metres per second. Provided each explosive gave the same volume of gases, having the same temperature and that the conditions were in all other respects alike, it is evident that the explosion in which the reaction velocity was the greater would be the more violent one. But they are not alike, since guncotton, nitroglycerin and mercuric fulminate, besides being endothermic compounds, are completely resolved into gases, while gunpowder, besides being a mixture, yields but about 44 per cent of gaseous products. The pressure developed by gunpowder when fired in a space completely filled by it is, from Noble and Abel's experiments, 6,150 atmospheres. The theoretical pressure developed by guncotton, nitroglycerin and mercuric fulminate when detonated in contact with bodies, are respectively 24,000 atmospheres, 25,000 atmospheres and 28,000 atmospheres. Investigation has shown that no other explosive known will give in contact an instantaneous pressure at all comparable with that of mercuric fulminate.

Owing to these differences in behavior explosives have been distinguished as high explosives and low explosives. Gunpowder and explosives of the nitrate class, together with smokeless powder are low explosives. They act with comparative slowness and are used where it is desired to lift or push a load without cracking it or in propelling projectiles. Nitroglycerin and explosives of the class of nitric

esters or nitrosubstitution bodies are high explosives. They are shattering and crushing in their effect. Detonators containing mercuric fulminate are used to fire high explosives, the detonators being themselves fired by means of a Bickford fuse or by an electric current. The high explosives are usually put up for use in paper cylinders, and, when loaded for shipment, these are called cartridges or "sticks." Usually several sticks are required for one borehole. In this case the detonator is inserted in one of these sticks, usually the last one inserted in the hole, and this stick is then called the priming cartridge or "primer."

#### Direction in Which Explosives Explode.

— There is a very common but erroneous belief that gunpowder explodes upward and that high explosives explode downward. It arises from the fact that if a quantity of dynamite be laid unconfined upon the surface of the rock on detonating it the rock will often be fractured, whereas if gunpowder is thus placed and fired, it produces no effect whatever upon the rock. The facts are that each explosive tends to act in all directions about the centre of explosion. As exposed in air they are subjected to the weight of the air above them and are to that extent under confinement. When the high explosive is detonated the gases are set free so fast that the air acts as a tamping agent; when the gunpowder explodes the gases are generated so slowly that they have time to move the air. Besides the "pressure in contact" exerted by the high explosives is enormously greater than that of the low explosives. That high explosives exert pressure in all directions was demonstrated by Munroe by fastening blocks of guncotton of equal size and weight on opposite sides of a plate of iron, but at some distance apart, by means of light cords or wires, suspending the plate in any position and detonating both charges simultaneously when holes were blown through the plate away from each of the charges. Although high explosives usually produce a shattering effect when fired unconfined upon a body the effect is markedly increased by increasing the confinement. Thus in the method of breaking boulders and large masses of stone called "plastering," after the charge is laid upon the stone and fused, one or two shovelfuls of earth are placed over it before firing. In "blockholing," when it is desired to break the rock into fragments of definite size, a small hole is bored in the rock and the explosive inserted in this cavity whereby the gases obtain a greater leverage.

**Explosions by Influence.**— In detonating explosive substances it has been found that the influence of the detonation is exerted to a distance all about the mass depending on the kind and the amount of the explosive used and its environment and that a second charge of explosive within the sphere of influence may be detonated by the detonation of the first charge without being in contact with it. Thus in accidental explosions in explosive works the initial explosion occurring in one building may detonate the explosives in other buildings unless care is taken in the construction of the works to separate the buildings by a safe distance from one another. Care, too, must be taken in forming fixed ammunition that the primers are not heavily charged with fulminate, and that the cartridge's are so packed that the accidental

explosion of one cannot explode the others by influence. Application of this principle is made in military engineering in the operation of countermining, the enemy's submarine mines being blown up by firing a heavy torpedo charged with guncotton in the vicinity of them. To-day large quantities of explosives are frequently used in big blasts. According to Eissler, it is an almost daily occurrence in California for 20,000, 30,000 and even 50,000 pounds of explosives to be used in a single charge. The system of large blasts has even become common in hard rock excavations, such as quarries and railroad cuttings, and in these large blasts it is common practice to dispose the larger part of the mass of explosive so that it may be exploded by influence and not by contact or by propagation of flame or fire.

The largest single blast ever fired was that used in the blowing up of Flood Rock at Hell Gate in the East River, N. Y., 10 Oct. 1885. There was used in the blast 240,399 pounds of rackarock and 42,331 pounds of dynamite, or 283,000 pounds of explosive. There were 13,000 separate charges of rackarock embedded in drill holes with a dynamite cartridge on top of each, and there were 591 primary charges of dynamite placed on timbers 25 feet apart within the mine. When all the charges had been placed in the excavation and the primary charges connected with the firing batteries, the mine was filled with water, the primary charges were exploded by the electric current and these exploded the 13,000 other charges by influence through the intervening water. Munroe founded on this principle a method of testing the relative sensitiveness of explosive substances.

**Uses of Explosives.**— The uses of explosives as propellents in war and in the chase; as rupturing agents in mining, quarrying and engineering operations, and as an essential component of fireworks is well known. It is not so generally known that they are employed for saving life and property in signal lights, rockets and guns; in projecting lines from the shore to stranded ships, and, in case of fire, to the upper stories of high buildings; in casting oil upon the water to quell a raging sea; and in railroad torpedoes to prevent collisions. Gunpowder guns are also used in bridge building to project a line across a chasm which is to be bridged, and they are used in the whale fishery to project the harpoons, while the latter may carry an explosive charge with which to stun or destroy the whale. Detonating explosives have been improperly used in taking fish; in burglarious operations against safes and vaults and in anarchistic outrages. Dynamite has been used to knock the blocking from the ways when launching ships. Fired on an iron plate placed on the top of a pile and covered with a tamping of earth or clay, it has successfully replaced the pile driver. It has been found efficient in excavating holes in which to plant telegraph and telephone poles and fence posts; in driving water out of quicksands in which foundations are to be laid or shafts to be driven; in slaughtering cattle; in breaking down ice dams to prevent inundations; in blowing up buildings to prevent the spread of conflagrations; in razing unsafe walls of burned buildings; in destroying wrecks which endanger navigation, and in freeing vessels which are hard aground on shoals. The farmer uses them in breaking



boulders, grubbing stumps and felling trees; in shaking the soil to fit it for deep-soil cultivation, and, in wine growing districts, to free the soils from the phylloxera: while their aid has been sought in breaking droughts and diverting hailstorms from their courses. The iron founder uses them in breaking large castings. The iron smelter employs them to clear out obstructions in blast furnaces while the latter are still in operation. Munroe proposed using detonating explosives as a means of testing the integrity of large masses of metal and their resistance to shock.

**Transportation of Explosives.**—It is well known that the transportation of explosives is a necessary menace. Munroe pointed out that in 1904 there was not less than 600 cars of explosives on the railroads of the United States each day. In 1905 the matter of regulating the transportation of these and other dangerous substances was taken up by the American Railway Association and a bureau of supervision was created. Later the matter was taken up by the United States Congress and by its acts of 4 March 1909 and 18 June 1910, this supervision and regulation was entrusted to the Interstate Commerce Commission which, on 2 July 1914, issued a pamphlet of 196 pages containing its regulations for the safe transportation of explosives, inflammables and other dangerous substances, and these now control.

**Explosives Industry in the United States.**—The reports of the United States census for 1900, 1905 and 1909 contain much descriptive and historical besides statistical matter regarding this industry. From the reports of the census for 1914 it appears that in that year there was produced 7,685,036 pounds of gunpowder; 208,316,125 pounds of blasting powder; 3,560,581 pounds of nitroglycerin; 223,000,073 pounds of dynamite and 18,113,601 pounds of permissible explosives. The comparative condition of the industry from 1840 to 1914 is shown in the following table:

TOTAL PRODUCTION AND VALUE OF EXPLOSIVES IN THE UNITED STATES BY DECADES, 1840-1914.

	No. of establishments	Capital	Average No. of wage earners	PRODUCTS	
				Pounds	Value
1840...	137	\$875,875	496	8,977,348	.....
1850...	54	1,179,223	579	.....	\$1,590,332
1860...	58	2,305,700	747	.....	3,223,090
1870...	36	4,099,900	973	.....	4,237,539
1880...	54	6,585,185	1,340	.....	5,802,029
1890...	69	13,539,478	2,353	98,645,912	10,993,131
1900...	97	19,465,846	4,502	215,590,719	*16,950,976
1905...	124	42,307,163	5,800	.....	29,602,884
1910...	86	50,167,976	6,274	487,481,252	40,139,661
1915...	111	71,351,414	6,306	486,824,427	41,432,970

\*This value is for the explosive substances only. When materials of all kinds produced in these establishments are included, the value is \$17,125,418.

The establishments reported for 1914 were most numerous in the sections where mining or engineering operations were carried on most extensively. Pennsylvania had 33 factories, Ohio 11, Illinois 9, New Jersey 8, West Virginia 7, Oklahoma 6 and California 5. The produc-

tion is largest in the East. See DYNAMITE; FIRE-DAMP; GUNCOTTON; GUNPOWDER; NITROGLYCERIN; MAXIMITE; PICRIC ACID; STABILITE; TRINITROTOLUENE, "T. N. T."

**Bibliography.**—Abbot, H. L., 'Report Upon Experiments and Investigations to Develop a System of Submarine Mines' (Washington 1881); Berthelot, M., 'Les feu gregois et les origines de la poudre à canon' (Paris 1891); Brunswig, H., 'Explosives,' trans. from German by Munroe and Kibler (New York 1912); Chalon, P. F., 'Les explosifs modernes' (Paris 1886); Cundill, J. P., and Thomson, J. H., 'A Dictionary of Explosives' (London 1895); Daniel, E., 'Dictionnaire des matieres explosives' (Paris 1902); DeKalb, C., 'Manual of Explosives' (Toronto 1900); Desortiaux, E., 'Dictionnaire des explosifs' (Paris 1892); Drinker, H. S., 'Tunneling, Explosive Compounds and Rock Drills' (New York 1882); Eissler, M., 'A Handbook on Modern Explosives' (London 1890); 'The Modern High Explosives' (New York 1893); Gody, L., 'Traite matieres explosives' (Namur 1896); Guttman, O., 'The Manufacture of Explosives' (London 1895); Hill, W. N., 'Notes on Certain Explosive Agents' (Boston 1875); Macquet, A., 'Explosifs de sureté' (Paris 1893); Marshall, A., 'Explosives, Their Manufacture, Properties, Tests and History' (Philadelphia 1915); Mowbray, G. M., 'Tri-nitro-glycerin as Applied in the Hoosac Tunnel' (New York 1874); Munroe, Charles E., 'Lectures on Chemistry and Explosives' (Newport 1888); 'Index to the Literature of Explosives' (Baltimore 1893); 'Chemicals and Allied Products, Bulletin 92 of the United States Census of 1905' (Washington 1908) and 'Chemicals and Allied Products, Vol. X, pp. 527-624, Report of 13th United States Census' (Washington 1911); Munroe, C. E., and Chatard, T. M., 'Chemicals and Allied Products, Bulletin 210 of 12th United States Census' (Washington 1902); Munroe and Hall, 'A Primer on Explosives for Coal Miners, Bulletin 17, United States Bureau of Mines' (Washington 1911); 'A Primer on Explosives for Metal Miners and Quarrymen, Bulletin 80, United States Bureau of Mines' (Washington 1915); Nobel, A., 'Les Explosifs modernes' (Paris 1876); Walke, W., 'Lectures on Explosives' (New York 1897); Wisser, J. P., 'Compressed Gun Cotton for Military Use' (New York 1886).

CHARLES E. MUNROE,

The George Washington University, Washington, D. C.

**EXPONENTS AND EXPONENTIALS.**

The symbol  $x^n$  is used in elementary algebra to denote the result of multiplying  $x$  by  $x$ , the result by  $x$ , and so on, till  $n-1$  multiplications have been made. It is read, " $x$  to the  $n$ th power," or simply " $x$  to the  $n$ th."  $n$  is said to be the exponent of  $x$ . Clearly this manner of defining exponents only applies to real integers. While the generalization of the notion of exponents has proceeded step by step, it is perhaps best to give directly the widest extension of the notion that is possible in ordinary complex algebra.  $a^x$ , the so-called exponential function, is defined

as  $1 + x + \frac{x^2}{2!} + \frac{x^3}{3!} + \dots + \frac{x^n}{n!} + \dots$ , which always converges when  $x$  is finite, be it real

or complex.  $\log x$  is defined as a value of  $y$  for which  $e^y = x$  is then defined as  $e^y \log x$ . It will in general be many valued. By the selection of certain values of  $xy$  as the so-called principal value, the following laws may be established.

$$x^m \cdot x^n = x^{m+n}$$

$$(x^m)^n = x^{mn}$$

$$x^m \cdot y^m = (xy)^m$$

It will be found that when  $m$  is an integer,  $x^m$  will have its conventional meaning, and that

$x^{\frac{m}{n}}$  will stand for  $n\sqrt{x^m}$  where  $n\sqrt{x}$  is a number which, when raised to the  $n$ th power, will yield  $x$ .

While  $e^x$  is the exponential function, functions the argument of which appears in an exponent are often known collectively as exponential functions.

**EXPOSITION, Industrial.** The promotion of trade and manufactures by means of collections of works of industry and art has no claim to the merit of novelty. In modern times, however, the idea has been more systematically carried out, and was probably suggested by the good effects produced by two institutions of a like nature—the galleries of rare productions of art or nature collected by the wealthy and educated, and the exposure for sale of ornamental and useful articles in the stores of individuals, and more particularly on a large scale at the great fairs which in former times were more important features of commercial enterprise than they now are. The beneficial effect thus derived from the exhibition and comparison of the manufactured products of different localities could not long escape notice. In England this knowledge was brought to practical purposes in the 18th century, when the Society of Arts in 1756-57 not only offered prizes for specimens of manufactures, but exhibited the works of the competitors. In France an exhibition embracing all kinds of manufactures was held in the year 1798, and another under the consulate of Bonaparte in 1802, and the gratifying results attained led to the idea of holding them every three years, which was carried out as far as the political troubles of the country would allow. Many exhibitions were subsequently held at different cities on the continent of Europe, and in the British Islands exhibitions of a more or less local nature were held in Dublin, Manchester, Liverpool and Birmingham, as well as in London in the premises of the Society of Arts. All these had been generally successful, but the necessity of having an exhibition on an international scale had become with some a fixed idea. This was first brought fairly before the British public in 1848 by Prince Albert, then president of the Society of Arts. In 1849 the project for an exhibition in which all nations might join began to take a tangible shape; and it was at last determined by government to issue a royal commission to deal with the matter, which was gazetted 3 Jan. 1850. The better to enable the commissioners to enter into contracts and otherwise incur obligations, subscriptions were procured to a guarantee fund, the queen leading the list with \$5,000. A vast structure of iron and glass, generally designated the Crystal Palace, built from the design of Joseph Paxton,

was erected in an incredibly short space of time in Hyde Park, London, and was opened by Her Majesty on 1 May 1851. The extreme length of the building was 1,851 feet, the width 408 and the height about 64 feet. The entire area was about 19 acres. In the ground floor and galleries there were about eight miles of tables set apart for the exhibitors. The articles sent for exhibition were divided into four great sections: Raw materials, machinery, manufactures and fine arts. The number of exhibitors was about 15,000. The exhibition remained open until 11 October, and the number of visitors during the 144 days amounted to about 6,170,000. After all expenses were defrayed there was a balance of \$700,000 left. The immense success of the undertaking encouraged the local and national exhibitions of Dublin and New York in 1853 and of Munich in 1854; and the French nation in 1855 opened its first Exposition Universelle. The main building was an imposing structure of white stone and of classic architecture. The buildings were erected in the Champs Elysées, and covered about 24 acres. There were in all about 24,000 exhibitors, and the contents were pronounced greatly in advance of those exhibited in London in 1851. It was said that continental manufacturers had taken lessons from the British exhibition which the British had failed in fully profiting by, and so exhibited a vast improvement in works in which the latter considered themselves unrivaled. This was followed by the national exhibitions of the Dutch at Haarlem and the Belgians at Brussels, both in 1861, and the following year by the second great international exhibition held in London. It occupied a vast brick building, lighted by a roof and two immense cupolas of glass, and erected in the garden of the Horticultural Society at South Kensington. The space covered was about 17 acres. There were 26,348 exhibitors in the industrial division, of whom 8,487 were British, and in the fine art division 2,305, of whom 990 were British. The aggregate number of visitors from 1 May to 31 October was 6,211,103, giving an average of 36,328 per day. The productions, which came from almost all parts of the globe, were divided into 40 classes, and included manufactures of all kinds—machinery, chemical products, railway plant and ordinary vehicles, animal and vegetable products used in food or manufacture, architecture, painting, sculpture, engraving, etc. This exhibition was also eminently successful and enabled the public to judge of the progress or shortcomings of British home manufactures and art as compared with others. In 1865 a rather important exhibition was held in Dublin which was a pecuniary failure. The second French International Exhibition was opened on 1 April 1867, and closed on 3 November. On 1 May 1871 the first of the British annual international exhibitions of fine arts and industry was opened by the Prince of Wales. On 1 May 1873 the first Austrian international exhibition was opened by the Emperor Franz Josef with great pomp and ceremony. The building was situated in the Prater, or, as it may be called, the park of Vienna and was 2,940 feet in length, with an average breadth of 570 feet. A great exhibition was opened by President Grant at Fairmount Park, Philadelphia, upon the occasion of the centennial festival of the American Declaration of Independence. It occupied 60 acres and had

nearly 10,000,000 visitors. A third French International Exhibition was held at Paris in 1878; area occupied 140 acres; visitors 17,000,000. A fourth French International Exhibition was opened by President Carnot in 1889 to commemorate the centenary of the Revolution, the visitors to which numbered over 25,000,000. One of its chief features was the Eiffel tower, of iron, 984 feet high. The series of exhibitions which were held at South Kensington, London, included The Fisheries (1883), The Health (1884), The Inventions (1885) and the Exhibition of Colonial and Indian products (1886); the latter of which was visited by 5,550,749 visitors. Besides these, exhibitions have been held in Edinburgh (1886), at which there were 2,769,632 visitors; Manchester (1887) at which there were 4,765,000 visitors; and Glasgow (1888), with 5,748,379 visitors. In 1899-1900 a huge International Exhibition was held at Paris, but, though visited by about 47,000,000 persons, was not a financial success. It occupied the Champ de Mars and extensive areas on both sides of the Seine.

In 1893 the fourth centenary of the discovery of America by Columbus was celebrated by the World's Columbian Exposition, at Chicago. It excelled all predecessors in conception, scope and grandeur. Every nationality contributed to the exhibits and many countries possessed their own buildings. The "White City," as it was called, was opened by President Cleveland 1 May and closed 30 October. It occupied about 600 acres, at Jackson Park, on the shore of Lake Michigan, including the "Midway Plaisance." Nearly every State in the Union was represented by its own edifice. The principal buildings were Machinery Hall, the Art Palace and those devoted to transportation, mining, electricity, agriculture, manufacture and liberal arts (covering 44 acres), government, administration, fisheries, horticulture and anthropology. The total admissions for the period named were 27,539,521, and the receipts from this source \$10,317,814. The largest attendance on any one day—Chicago day, 9 October—was 716,881. Other notable exhibitions in the United States were the California Mid-Winter Exhibition, held in San Francisco in 1894; the Cotton States and Industrial Exposition held in Atlanta, Ga., September to December 1895; the Tennessee Centennial Exposition, held in Nashville, Tenn., 1 May to 31 Oct. 1897; the Trans-Mississippi Exposition in Omaha, Neb., 1 June to 1 Nov. 1898; the Pan-American Exposition, in Buffalo, N. Y., from 1 May to 2 Nov. 1901; the South Carolina Inter-State and West Indian Exposition, held in Charleston, from 1 Dec. 1901 to 1 June 1902, and the World's Fair at Saint Louis, Mo., in 1904, in celebration of the Louisiana Purchase, drew 19,694,855 attendance and cost \$15,000,000; the Lewis and Clark Exposition in Portland, Ore., 1 June to 15 Oct. 1905; the Jamestown Tercentenary Exposition, at Hampton Roads, Va., 26 April to 30 Nov. 1907; the Alaska-Yukon-Pacific Exposition at Seattle, Wash., 1 June to 30 Nov. 1909; the Panama-Pacific Exposition, to celebrate the opening of the Panama Canal, held at San Francisco, 20 Feb. to 4 Dec. 1915, drawing a total attendance of 18,871,957; the Panama-California Exposition, at San Diego, Cal., 1 Jan. to 31 Dec. 1915.

The Brussels Exposition in Belgium, 23 April to 14 Nov. 1910, drew 13,000,000 people;

the Turin Exposition, 30 April to 31 Oct. 1911, celebrated the 50th anniversary of Italy as a kingdom. See FAIRS AND SHOWS.

**EXPOSITION OF ORACLES OF THE LORD** by Papias of Hierapolis, an important Greek work in five books to which the date 145-60 is assigned. It is described by Lightfoot as "among the earliest forerunners of commentaries, partly explanatory, partly illustrative, on portions of the New Testament," and is a connecting link between the Apostolic and the Apologetic ages, explaining the less understood of Christ's sayings in the light of definite Apostolic traditions concerning them. No complete copy of the work has been discovered, but it is known through the excerpts quoted by the early Christian Fathers Irenæus and Eusebius. See PAPIAS.

**EXPOSITION OF THE SACRAMENT**, in the Roman Catholic ritual, the public showing of the Blessed Sacrament, accompanied with certain ceremonies, for the veneration of the faithful. Until the 16th century the practice was not general, taking place only on the feast of Corpus Christi, but within the last 300 years the practice has become general. Formerly permission of the bishop was required for an exposition. The 40-hour adoration is now a common practice in the larger Catholic centres even in the United States. The ceremony is begun and ended with a mass. Consult Maier, 'Die liturgische Behandlung des Allerheiligsten ausser dem Opfer der heiligen Messe' (Ratisbon 1860) and Raible, 'Der Tabernakel einst und jetzt' (Freiburg 1908).

**EXPRESS SERVICE.** A transportation system for parcels which require a safer and quicker delivery than can be had through the common freight service.

The creation and development of express service in the United States and the extension of the American express system, under American control, throughout the length and breadth of the civilized world and beyond, affords convincing proof of unique constructive and administrative genius along the lines of greatest utility to mankind.

One of the most prominent, successful and progressive express companies, now operating on every continent, began some 70 years ago with a simple service for delivery of packages between a few Eastern and Western points. To-day, the same organization has, in addition to traffic in the United States, British North America and the Latin-American republics, at least a dozen agencies with commodious quarters on leading thoroughfares in principal European cities, each fully equipped with men, wagons and horses for the most rapid and effective express service.

As part of its routine business, the company is in touch with 30 of the world's largest banking institutions and has shipping and banking correspondents at all large cities and ports in both hemispheres. As a means of comparison with express conditions of half a century ago, when the system was merely an adjunct to the railroads, a brief outline of the work now being carried on in progressive express companies will be of interest. Since the express plan first began, in 1838, the relations of the railroads toward the express companies have, by mutual consent and to meet ever-

growing demands, been reversed. The railroads, in their own interests, so far as carriage of express freight is concerned, are now adjuncts of the express companies.

The most modern American express service, when conducted on a large scale, is conducted under five divisions: (1) The transportation of merchandise; (2) transfer of money, precious stones and other valuables, securities, etc.; (3) purchasing and selling merchandise; (4) forwarding of imports and exports; (5) issuance of money orders, letters of credit, travelers' checks and the transmission of money by telegraph.

The "check" system has been so perfected that travelers in foreign countries save time and avoid delay by their use, as they are promptly recognized and cheerfully cashed or accepted by the principal hotels, steamship and sleeping-car companies, by many railroad companies and by merchants, shopkeepers and others, in settlement of accounts. They are issued in the denominations \$10, \$20, \$50, \$100 and \$200.

For those traveling in the United States, Canada, Mexico, Central and South America, these checks afford the advantages of a secure and convenient means of carrying funds immediately available, combined with the avoidance of the risk of loss of money by fire or destruction and of annoyance of negotiating personal checks in places where such may be unacceptable. Being cashed by agents of the companies and by banks in all the principal cities and pleasure resorts of the United States, the Canadas, Mexico, Cuba, Central and South America, accepted in payment of fares by the principal steamship companies and many railroad companies throughout the United States and received as cash by agents and conductors of the Pullman Palace Car Company and by many hotels in settlement of account, travelers' checks are found to be a most satisfactory form of credit for use during a tour.

"Letters of Credit" now form a usual express office specialty. These documents are drawn in sterling and are available in all parts of the world. Through the Letters of Credit system, checks may be obtained from express agencies at all important points. Every foreign express correspondent has a cable address, also every express agency.

The "C. O. D." system and bank of account collection are among the useful developments of express service. "C. O. D." shipments are subject to collection of bill or invoice for the goods, with prompt return of proceeds made at a small charge for such service. C. O. D. shipments to foreign countries are usually made under the same system as applies to domestic points.

Several of the big express companies attend to the collection of accounts, bills, notes, drafts, etc., in any part of the commercial world. Collections in United States and Canada are effected with unusual promptness and at less risk and cost to payee than by other methods. Collections in foreign countries of drafts or deposits, or by powers of attorney, are undertaken by express companies through their own organizations in Europe or through banking correspondents. The proceeds of C. O. D.'s or collections are transferred by cable when patrons desire, with a charge for collecting, plus only the cost of cablegrams.

The transfer of money is another useful and much appreciated feature of express service. Purchases are made and commissions executed for patrons, in the quickest possible time, at places in United States, Canada and Europe, by a special department. Besides attending to orders for the purchase or sale of goods and property, including household supplies, this department pays tax bills, redeems articles pawned, collects baggage at railroad stations, secures seats at theatres, berths on sleeping cars, staterooms on steamboats, baggage and staterooms on European steamers. Rare goods or books or articles requiring exact matching, or the maker or seller of which is unknown, are obtained without annoyance or loss of time to patrons.

Imports and exports of every class and size are handled by express companies as a part of their regular business. Bills of lading, bills of exchange and all other documents of that character are prepared and attended to from first to last.

Money orders and drafts are issued by several express companies for any amount, at the posted rate of exchange, in sterling, francs, lire, lei, marks, kronen, rubles, kronen, gulden, finmarks, Turkish pounds, Mexican dollars, local dollars, pesos, rupees, yen and United States dollars on all parts of the commercial world.

The regular transportation service of express companies includes merchandise, parcels, produce, money, bonds, valuables and baggage. The routes extend over 250,000 miles of railroads in the United States alone. Shipments are frequently made in through express cars with burglar and fire-proof safes for valuables and iron express trunks for parcels, all in charge of special armed messengers. The swiftest trains are almost invariably used for express service. The aim of the companies is to cover the ground in the least time at the lowest rates. They accept entire responsibility for loss or damage. Some express companies run special express trains to facilitate business during very busy seasons. Other companies have this feature as a permanent arrangement.

Novel and highly useful features of the most modern express service are the securing of ocean passages, European railroad tickets and passports for patrons at a nominal charge. It is only necessary for those who desire to utilize express companies in this way to state their wishes — the companies do the rest rapidly, perfectly and inexpensively.

So much for the work-scope of express companies to-day as compared with that of earlier periods. Before reviewing briefly the evolutionary processes connected with express service developments it may be well to mention what has been brought about through the use of express enterprise and by such methods as are peculiar to the service.

1. The creation of wagon service, and, in connection with this, special cars and trains for transportation of express matter at high speed.

2. The creation of transportation business for carriage to and from all advantageous producing points of game, poultry, fish, oysters and fruit to localities where these commodities are not easily obtainable.

3. The creation of a novel method of selling goods for merchants by collecting on delivery

the amount of invoice and returning cash to the shipper.

4. The creation of a method of collecting the proceeds of negotiable paper and assuming, for the time being, responsibility of endorsers.

5. The creation of an efficient means of safe transportation of moneys and valuables shipped by individual citizens and by firms, banks, railroads and the government. As much as \$4,000,000,000 have been shipped in the United States through the express companies in a single year in this manner.

6. The creation of a vast and perfect network of money-order agencies. The present number of these agencies is estimated at 40,000.

7. The creation of improved facilities for immediate transportation of foreign goods from ports of entry to destination. Heavy bonds are demanded by the government and given for proper execution of this service.

Commonly, the express company owns its terminal facilities, and rents from the railroads the cars on which its traffic is carried. These cars are usually attached to the regular passenger trains, and the employees of the express company accompany the shipments, and attend to the delivery to local agents along the route. The contract with the railroad company secures to the express company exclusive rights to operate over that line. For the privileges conveyed the railroad company receives from 45 to 55 per cent of the gross collections on the merchandise traffic. In some instances, however, the share of the railroad reaches 60 per cent, and even 70 per cent, and in a few exceptional cases all of the express earnings in excess of the actual expenses are paid to the railroad.

Under the law the express company is a common carrier, and its rates are under the supervision and control of the Interstate Commerce Commission—as well as under the jurisdiction of State Railway Commissions in most of the States. For the purpose of fixing rates the Interstate Commerce Commission has divided the area of the United States into five great zones: (1) The country lying east of the Mississippi River and north of the Ohio River: in this zone the minimum rate per 100 pounds has been fixed at 60 cents. (2) The country lying south of the Ohio River and east of the Mississippi, together with a small section west of this river: in this zone the minimum rate per 100 pounds is 65 cents. (3) The trans-Mississippi country extending to the intermountain section: in this zone the minimum rate per 100 pounds is 70 cents. (4) The intermountain country: in this zone the minimum rate per 100 pounds is \$1.05. (5) The Pacific Coast States, in which the minimum rate per 100 pounds is 70 cents. The whole territory is divided into 950 "blocks" having a uniform length of 69 miles, and widths which vary from 45 miles along the northern border to 62 miles along the southern border; in about 100 of these blocks there are no express offices. The blocks are subdivided into "squares" or sub-blocks. The blocks are designated by numbers running in series from right to left across the map, the northernmost row beginning with 101, the next row toward the south beginning with 201, the next southerly row beginning with 301, and so on. Transportation is then designated as from 403F (Portland, Oregon) to 952A (New York, N. Y.).

Express charges are based on a classification into three divisions: (1) ordinary merchandise; (2) specials; and (3) what is commonly called "Section D"—newspapers, books, printed matter, seeds and scions, etc. Bulky and fragile merchandise is charged multiples of the first-class rates; as, for example, carriages at six times first-class, and racing shells or airships at eight times the first-class rates. As is the case with freight traffic on railroads there has been established by the express companies a schedule of "commodity rates" which allows the transportation of merchandise of relatively low value at a reduction from the regular rates (which would be prohibitive)—a lower class rate on carload lots, or a first-class rate on goods which would regularly take several times that rate. On the regular tariff the limit of liability on the part of the express company is \$50 on a shipment not exceeding 100 pounds in weight. If the property shipped is valued at more than this figure the rate is higher, and the higher rate must be paid to secure the full value of the package in case of loss or damage. The express company is liable only to the extent of the valuation declared by the shipper, and when the full charges have been paid or charged on that valuation.

#### Origin and Evolution of the Express Idea.

— The "Express" idea sprang from the system of sending parcels in care of coach-drivers, by stage-coach, and from the shipping of such parcels in care of captains, by coasting vessels.

When the railroads took the place, gradually, of the coaches, much parcel traffic was performed by means of the steam cars. Then the conductors of these cars had to assume responsibility for safe-keeping. Eventually, this transfer overcrowded them with work. A division of duties naturally followed. Finally, the railroads insisted that their employees should choose between railroad and the supplemental delivery traffic.

The principal events following this decision were:

1838-39. The starting of an express company to operate in New England. Alvin Adams, who later began business for himself in New York, was with this company.

1839. "Harnden's Express" started between New York and Boston.

1840. "Adams' Express" began operations between the same points.

1840-45. Other expresses opened up business, extending service to Philadelphia, Baltimore, Washington, Buffalo, Pittsburgh, Detroit, Chicago, Cincinnati, Louisville, Saint Louis and New Orleans.

The men most active in the new field at this time were William F. Harnden, William B. Dunsmore, Henry Wells, Edward P. Sanford, Samuel M. Shoemaker, Johnston Livingston, and William G. Fargo.

Almost all of the western transportation was carried on over the Ohio, Mississippi and Missouri rivers, with their tributaries, which included canals then recently completed in several of the States to connect those rivers with the lakes.

From 1840 the construction of railroads continued uninterruptedly, express business expanding in proportion. Then came the inauguration of express "continuous lines," enabling

goods to be carried quickly between many points without transfers.

At this period people sent their letters by express as being safer than the government's mail service. In course of time the authorities at Washington protested, and finally prohibited by law the private conveyance, without United States contract, of private letters.

1848. The stampede of gold-seekers, 1848-49, to California, brought out a great extension of the express system. Money and gold-dust were transmitted direct from the coast to eastern points through the express companies, many new agencies being established for the purpose.

1854. In this year a consolidation of express interests took place. "Adams & Co." bought up Harnden's business and worked several minor Eastern routes and secured the right to much Southern traffic.

During the same year the "American Express Co." first established in 1841 was formally organized, to operate from the East to the Far West.

The "United States" express also came into existence in 1854 to operate along the New York and Erie Railroad and the route running westward.

1854-55. About this time "Wells, Fargo & Co." were organized. They started the famous "Pony Express" and several stage lines. Other firms competed in these special forms of rapid transportation.

1855. The "National" Express Company began operations in this year, with routes between New York, Albany, Troy, Saratoga, Whitehall, Rutland and Montreal.

1858. Wells, Fargo and Company and the Pony Express lines organized the "Overland Mail Co.," which, until the completion of the Union Pacific Railroad, carried the whole of the United States mails between the Missouri River and the Pacific Coast. By this time the express had become a recognized necessity in the commercial and individual transactions of the country. Its lines had amplified in every direction. It had attracted to itself sufficient capital to place it on a firm financial basis. Obligations to ensure the safe and speedy transmission of merchandise, valuables and money were readily assumed. When loss or damage occurred, due reparation was promptly made. Thieves were and are, to-day, followed up by them until caught and punished.

1861. Henry S. Plant and associates organized the "Southern Express Co.," which operated principally in the Southern States.

1861-65. Upon the breaking out of hostilities, the express was the only means of communication between soldiers in the field and their friends at home. Government securities, being purchased largely by the people, were sent by government through the express, it being officially recognized that, during that critical period, the express was much safer than the official mail service.

After the war a contract was made by the United States government with the Adams Express Company, acting for itself and other companies, to transmit all securities and moneys of the government by express.

1865-1918. This period represents a phenomenal growth of the express movement. The present organization of the great companies, each with experience of over half a century to

guide it, is practically perfect in its workings, and labors continuously at high tension to keep even pace with calls which increase day by day.

The establishment of the parcel post in 1913 and its subsequent extension to larger packages had marked effect on the business of the express companies. A scaling down of rates by the Interstate Commerce Commission in 1914 seemed likely to affect the financial condition of the companies. The United States Express Company retired from business on 30 June 1914. But the later years have witnessed but little diminution of the bulk of the traffic and the profits. For valuable packages and for promptness in transmission and delivery the express company is an unequalled public utility.

The first statistics of the express business were gathered in 1890. In that year 18 companies were operating over routes which aggregated 174,060 miles. At the close of the fiscal year which ended 30 June 1916, the general business was in the hands of eight companies operating over a total of 297,139 miles: of this, 253,750 miles were on steam railroads, and 43,389 miles on other routes—electric railways, steamboats and stage routes. The mileage served was divided among the companies as follows: Wells, Fargo and Company, 107,529 miles; American, 74,280 miles; Adams, 45,153 miles; Southern, 34,765 miles; Canadian, 12,050 miles; Great Northern, 9,838 miles; Northern, 6,275 miles; and Western, 5,249 miles. The combined revenues of all the companies for the fiscal year were \$173,709,411, of which sum \$172,655,204 was from the ordinary domestic express transportation business. Out of these revenues the express companies paid for exclusive privileges and transportation of merchandise to the carrying companies, \$87,971,137, leaving their net revenues at \$85,971,136. To this was added an income of \$5,497,238 from the money-order and similar non-transportation business. Out of the net revenues, \$68,020,529 was paid out in expenses, and \$4,527,474 for maintenance. Taxes amounted to \$1,548,761, and the total net profit on the year's business was \$10,560,650.

The largest carrying business was done by the American Express Company, amounting to \$57,039,124; Wells, Fargo and Company were second, with \$45,366,216; and Adams Express Company third, with \$42,018,735. The largest net profit was made by the Southern Express Company, 9.5 per cent on the year's business; as compared with 6.3 per cent by Wells, Fargo and Company; 5.8 per cent by the American Express Company; and 5 per cent by Adams Express Company.

The latest available official statistics as to the capital, property and equipment of express companies in the United States are those for the fiscal year ended 30 June 1914. In that year the combined working capital of all the large companies amounted to \$186,815,717, of which sum \$75,760,300 was stock. The real estate owned was valued at \$16,446,269, and the equipment at \$17,547,845; the latter sum included 155 railroad cars valued at \$603,787. The number of money orders, travelers' checks, letters of credit, telegraphic transfers of money, etc., was 24,209,695, representing the aggregate sum of \$537,099,796.

Consult Chandler, W. C., 'The Express Service and Rates' (Chicago 1914); Interstate

Commerce Commission, Document 4198, 'Express Rates, Practices, Accounts and Revenues' (Washington 1913); and the annual reports of that commission.

**EXPRESSED OILS**, in chemistry, oils obtainable from bodies by pressing, to distinguish them from mineral and essential oils, which last are obtained by distillation.

**EXPRESSION**. Our mental states, and particularly our emotions, are closely linked with certain muscular and physiological associates, which are exhibited in perhaps the greatest detail and variety by the muscles and blood vessels of the face. These associates are denominated expressions; they include not only the visible muscular and vascular phenomena which have already been indicated, but also a vast number of more or less obscure respiratory, circulatory and secretory changes. These changes and movements are at times striking in their apparent inutility, so that much labor has been spent in the effort to elucidate their reason for being. The first explanation of the expressions which possess much interest at the present day is that of Darwin. In accordance with his evolutionism, he regards many emotional expressions as rudiments of actions which have been useful to the animal either in its individual history or in the history of the race. An acquired example of this sort is the pointing of the pointer dog. Other expressions are held to be the result of tendencies opposing those which would be called into play by the opposing emotion. A dog approaching its master playfully will evince in its relaxed muscles, in its bent back, in its flexed limbs, in its wagging tail and ears laid back, actions exactly the opposite of the tense sinews, the straight back and forward pointed head, the rigid extended limbs, the uplifted tail and ears which betoken its desire to attack another dog and serve to frighten its antagonist or to facilitate its attack. The third factor in the production of emotional expression, according to Darwin, is the direct overflow of the excited nervous system into motor channels, as in the case of trembling from fear.

Wundt retains Darwin's third principle of expression, but replaces the other two by the principle of association, which causes an experience to assume the physical correlates of related experience, and the principle of the connection of movement with sense-ideas, which includes all cases of movements which indicate or symbolise the object of the emotion or its desired result. The facial expression of dislike is an example of the former of these principles; it represents an attempt to eliminate a bitter-tasting substance from those parts of the mouth where it will be tasted most. Examples of the second principle are the stare of surprise or the clenching of the fist in anger.

James retains Darwin's first principle that many expressions are rudimentary purposeful actions, and Darwin's third principle of nervous overflow. He adds to these what is equivalent to Wundt's principle of the association of analogous sensations, and two new explanations of expression. The first of these is that not only are formerly useful emotional expressions retained as rudiments, but that their physiological consequences and concomitants undergo a like atrophy and schematisation. Be-

sides all these, there is a class of reactions susceptible to no very simple explanation. These have been perpetuated in a more or less mechanical manner, independently of their mode of origin. Perhaps the greater number of facial expressions belong to this class.

In accordance with the James-Lange theory of the emotions, which holds that they are constituted by their expressions, James maintains that there are distinct and different expressions of every emotion. This has been denied by Cannon, who has made perhaps the most thorough physiological investigation into the actual nature of emotional expression. He finds that all intense emotions are characterized by the increased secretion of adrenalin and the liberation of the carbohydrates stored in the liver. These reactions are directly serviceable to the individual in whom they happen (1) because they cause the blood to be driven from the abdominal viscera to the muscles, heart, brain and lungs, where it is more needed in any sudden action; (2) because they release an immediately available store of energy; (3) because they cause the heart to act more vigorously and more rapidly; (4) because they increase the clotting power of the blood and decrease hæmorrhage in case of injury. The milder emotions, on the other hand, are characterized by a directly antithetical physiological process, in which the normal action of the digestive system and other abdominal viscera is helped rather than hindered. The milder emotions are associated with a preponderant activity of the cerebro-spinal nervous system, while the violent ones belong rather to the sympathetic system. See EMOTION.

**Bibliography.**—Cannon, W. B., 'Bodily Change in Pain, Hunger, Fear and Rage' (New York 1915); Darwin, 'The Expression of the Emotions in Man and Animals' (London 1873); James, W., 'Principles of Psychology' (New York 1890); Mantegazza, P., 'Physiognomy and Expression' (3d ed., London 1904); Warner, F., 'Physical Expression' (New York 1886); Wundt, 'Grundzüge der Physiologischen Psychologie' (Leipzig 1911); 'Völkerpsychologie' (Leipzig 1900).

**EXPULSION**. Usually this word is used to describe the act of depriving one or more members of a political or corporate organization, or of a society of their right of membership. The act is frequently brought about by a vote of the organization or society after the submission of a committee report, for some violation of duty or some other offense rendering such member or members, in the opinion of their associates, unfit or unworthy.

It is provided in the Constitution of the United States that the members of the Senate or House of Representatives may expel members of their respective bodies, by a two-thirds vote, for disorderly conduct.

Corporations have the right of expulsion in cases where good order and proper control make the exercise of such power essential as, for example, (1) when the offense is not within corporate duties, but nevertheless disgraceful or infamous, or (2) when the offense is against his duty as a corporation member or officer or director, or (3) when the offense is of such a character as to infringe corporation rules and the statutes at the same time.

Before a person can be expelled from a corporation or society for disgraceful conduct outside of the jurisdiction of such organizations, a previous conviction by jury is necessary. If the offense is against or in violation of corporation or society rules or duties, a trial and conviction may be had before the authorities of the organization.

The word "expulsion" is also used to describe the ejection of people from meetings when they create a disturbance or otherwise make their presence obnoxious. Those who convene meetings have, under the law, the right to expel objectionable persons, providing they use only as much force as is necessary for the purpose.

Club members are liable to expulsion under the rules of the club to which they belong. They have an appeal to the courts for reinstatement on the ground that membership in a club is a form of property.

Non-members of any organization, if present at any meeting of such organizations, are liable to expulsion.

The Constitution of the United States provides that Federal judges cannot be expelled from their posts during good behavior. See **DISFRANCHISEMENT**.

**EXPUNGING RESOLUTION.** See **CENSURE, CONGRESSIONAL**.

**EXTENDED ORDER.** See **INFANTRY; TACTICS, MILITARY**.

**EXTENSION**, in physics and metaphysics, that property of a body by which it occupies a portion of space. Extension is an essential as well as a general property of matter, for it is impossible to form a conception of matter, however minute may be the particle, without connecting with it the idea of its having a certain bulk and occupying a certain quantity of space. Every body, however small, must have length, breadth and thickness; that is, it must possess the property of extension. Figure or form is the result of extension, for we cannot conceive that a body has length, breadth and thickness without its having some kind of figure, however irregular. In logic, extension is the extent of the application of a general term, that is, the objects collectively which are included under it; thus European is more extensive than French, Frenchman, German, etc. Matter and mind are the most extensive terms of which any definite conception can be formed. Extension is contrasted with comprehension or intension. See **PHYSICS**.

**EXTENSION.** While our spatial experiences undoubtedly contain many elements which are noted for a peculiarly spatial nature, the predominance of psychological opinion is that certain experiences possess the unanalyzable primitive attribute of extension. Though the existence of this attribute is denied by Wundt and is attributed to all sensations by James, it is generally held that it exists and is confined to cutaneous, visual and possibly to kinæsthetic sensations. The "vastness" which James mentions as pertaining to such experiences as those of hearing is in all probability a complex of various degrees of intensity, clearness and other sensory attributes.

While sight and touch are endowed with the attribute of extension, this extension is only two-dimensional. Everything which we

see is stretched out over the surface of the retina, and everywhere we feel is stretched out over the surface of the skin. The transition from two to three dimensions involves an appeal to experiences which are neither visual nor cutaneous, and which, in a large measure, are not specifically spatial. In the case of vision these are (1) The difference between the images on the two retinae. (2) The experience of strain in the muscles which make the two lines of vision converge. (3) The experience of strain in the muscles of accommodation. (4) The experience of clearness of vision when the eye is focused on an object, and of blurredness when it is not. (5) Geometrical perspective. (6) Atmospheric perspective. (7) The partial obliteration of more remote objects by nearer ones. (8) The parallax of the various objects of vision, consequent upon motion of the head or of the entire body. (9) The visual angle subtended by known objects. (10) The effect of light and shade.

In the case of touch, the muscle and joint sensations indicating the position of the various parts of the body are of the utmost importance in giving knowledge of the third dimension.

The various tactile and kinæsthetic limina of extension are discussed under **LOCALITY** (q.v.). At the fovea of the eye, the lower limen of visibility, or "minimum visibile," is probably the angle subtending a single cone or from half to a whole minute of arc. Objects subtending smaller angles can be perceived, and even compared in size, but it appears that this is due to the differences in the intensity of the stimulus exert and the sensation they cause, quite apart from the extensity of the latter, and that the real area stimulated is at least an entire cone. The least distance at which two objects can be distinguished is about a minute of arc at the fovea, but near the periphery of the retina it is as great as two degrees or thereabouts. The sensation experienced when a small point of light is seen often lacks all colors. It takes a larger area of stimulus to evoke color, and often a still larger area to evoke the color which we should normally associate with the source of light.

Extension obeys Weber's law (q.v.). The least noticeable increment of a linear visual object is about one-fiftieth the length of the latter, if movement of the eye is allowed. It is considerably larger when the eye is kept at rest; but as is obvious, measurements with the eye at rest are by no means easy. The field of vision is rather irregular in outline. It extends (from a line connecting the centre of the pupil to the macula lutea) about 80 degrees outward, 65 degrees inward and 65 degrees downward. Of this, about two-thirds can be seen by both eyes. (See **SPACE**). Consult James W., 'Principles of Psychology' (New York 1890); Külpe, 'Outlines of Psychology' (London 1909); Titchener, E. B., 'Text-Book of Psychology' (New York 1910); Wundt, W., 'Grundzüge der physiologischen Psychologie' (Leipzig 1908-11); 'Introduction to Psychology' (London 1912).

**EXTENSION, University.** See **EDUCATION; UNIVERSITY EXTENSION**.

**EXTENSION TEACHING.** See **HOME ECONOMICS; UNIVERSITY EXTENSION**.



**EXTENUATING CIRCUMSTANCES,** in legal practice, those circumstances, in connection either with the position of the prisoner or with the act alone, which are taken into consideration by the court in mitigation of the punishment. The previous good character of the person convicted may always be proved as a circumstance giving him some claim to leniency of punishment. Besides character, there are other circumstances, the presence of which in a case sometimes serves to mitigate the sentence, sometimes to take the act done out of the category of crime altogether. One is youth. Thus, no act done by any person under seven years of age is a crime. Defective mental power in the person convicted will always be considered in determining the severity of his sentence. Such disease of mind as prevents a man from knowing that the act he does is wrong will excuse him from the consequences of an act otherwise criminal. Drunkenness, when voluntary, is not held an extenuating circumstance, but if a man is made drunk by the fraudulent administration of drugs, and while under their influence kills another, not knowing what he does, the act is not a crime. It is a good excuse for persons charged with crime that they have been compelled by others by threats of death or great violence to do the criminal act; and the acts of a married woman in presence of her husband are presumed to be done under his coercion, and so, unless the presumption is rebutted, will be excused. Ignorance of the law is no excuse for an offense. Nor, in general, will ignorance of facts be a good excuse, though in particular circumstances it might form a valid defense. Sir James Fitzjames Stephen states, in language purposely vague, to represent the vagueness of the law, a principle under which the stress of necessity is held to excuse acts otherwise criminal: "An act which would otherwise be a crime may in some cases be excused if the person accused can show that it was done only in order to avoid consequences which could not otherwise be avoided, and which, if they had been followed, would have inflicted on him or on others whom he was bound to protect inevitable and irreparable evil, that no more was done than was reasonably necessary for that purpose, and that the evil inflicted by it was not disproportionate to the evil avoided."

**EXTERIOR BALLISTICS.** See GUNNERY.

**EXTERIOR BOUNDARIES.** See BOUNDARIES OF THE UNITED STATES.

**EXTERIOR MURAL PAINTING.** See MURAL PAINTING.

**EXTINCT ANIMALS.** Many animals which inhabited the earth in bygone periods have entirely disappeared, leaving not even a modern representative of their race. Others, no doubt, were known to prehistoric peoples, concerning which no record has come down to us. But within the period of recorded observations, many animals have lived and died out; various causes contributing to their extermination, not least among these being the presence of mankind. Man reconstructs the face of the earth to suit his needs: he cuts down forests, plows or burns over prairie lands, changes the course

of rivers, drains the swamps and thus destroys the natural environment of many of nature's wild children. Then, too, he destroys creatures directly; he kills them for food, for clothing or for other utilitarian purposes; he hunts them because he fears them, as dangerous foes to himself or to his agricultural pursuits; he destroys them for his sport; and, finally, he draws them from feral conditions by domestication. Not only thus does man directly injure the wild creatures, but his coming, accompanied by exterminating influences, kills out certain other creatures. These, when man has destroyed their natural prey, practically die of starvation before they can adapt themselves to changed conditions. Then the domestic dogs, cats, etc., help on the work of slaughter in certain ways, by preying upon wild life.

That prehistoric man was partially responsible for the extinction of certain animals, scientists are agreed; but they are also assured that except in the cases of the horse, the camel, and perhaps the domestic dog, the extinction was due more to their inability to adapt themselves readily to the changes of climate of that remote time than to human agency. The wild progenitors of the horse and camel have not been known in historic times. That aboriginal man in Europe aided the elemental forces in their work of destruction, by hunting to death the mastodon and the great cave-hunting lions, bears and hyenas, and other huge creatures of his time, is most probable; but in America this is not at all likely to have been the case.

Since the earliest records were made, however, various species have been eliminated from the European fauna; many from that of the other continents as well. In the days when the Romans fought the Dacians, various members of the cat family were common along the Rhine-Danube frontier, among them, lions, tigers, leopards and wild-cats. They found also the great herds of wild cattle, which have entirely vanished. The ibex, too, is gone, and, but for the protective legislation, the chamois and the deer would have been exterminated as well. The bear, the beaver, the wolf and the wild boar have all gone within the last 10 centuries, from Britain, the wild-boar, which was hunted by royal cavalcades, disappearing at the close of the 17th century.

Records concerning Asiatic animals show few cases of extinction except those of a few cases of a species of sea-cow native to the Commander Islands, off the Kamchatkan coast. This animal, the rhytina, was pursued for its flesh, chiefly, and, so far as is known, the last survivor was killed in 1768. Among the same islands lived the now extinct Pallas's cormorant, a great bird also exterminated because of its edible quality.

Animals which are restricted in habitat to small islands seem liable to suffer from the inroads of man, more surely and swiftly, because they have no adequate means of escape, many such examples being furnished of birds whose power of flight is limited. Such species, especially in the Australasian and South Sea islands, have been in almost all cases destroyed; notably several representatives of the moa tribe in New Zealand, the dodo, the solitaire and certain parrots, rails and fowls. The disappearance of the gigantic edible tortoises from the islands

of the Indian Ocean and from the Galapagos presents another striking instance of the extermination of animals owing to man's depredations.

Both Africa and America have presented fields for indiscriminate slaughter. In the former continent, where once there roamed great herds of antelope, countless buffaloes and elephants the slaughter has been so great since the middle of the 19th century as to leave many of these denizens of plain and forest extremely rare if not altogether extinct. The search for hides was perhaps the strongest destructive force; but the European hunters for "big game" and their followers have done much in the same direction. The mountain zebra, the quagga and various species of antelope are examples of this; while the giraffe to escape entire extinction has retired to almost inaccessible regions in the Kalahari Desert and northward.

As for America, with her long list of lost species, most people are more or less acquainted with the efforts that have been made (and sometimes with signal success), within the past few years, to save, by protective legislation, such of her native birds as are still found, and to prevent the wholesale slaughter of her wild denizens of field and forest. The best-known example of extinction is furnished by the bison (q.v.), which roamed in vast herds over the grass lands, until it was destroyed by hide-gatherers; so that now there are no wild bison except one small herd, carefully protected by law, dwelling beyond the North Saskatchewan River. In 1903 it was estimated that only 34 wild bison were left in the United States, and about 600 in Canada; and even these remnants had more or less degenerated from the superb original type of the plains. Such large animal species living under strenuous conditions and necessarily breeding slowly, urgently require protection at this time. The unremitting warfare against all the animal kind that began with the destruction of the great land turtles and moas in prehistoric times, now extends to the remotest places of the earth. With the arming of every savage tribe, and with shooting expeditions often organized on a large scale and even carried out under the guise of scientific exploration, all large animal types are to-day threatened with a speedy extinction. A typical case of natural restriction accelerated by man is that of the muskox (q.v.). Circumarctic in the Pleistocene this curious animal, yielding in quantity a strong underwool with a texture as fine as silk, is now confined solely to the treeless arctic wastes of North America and the islands to the north. Cut off by the white hunter everywhere to the south, the Eskimo rabbit-catchers of the far north, always hard on the muskox, are now killing with modern rifles the northern remnants of the original herd. The American sea-elephant and the monk-seal are also practically gone. The long lists of birds, from the great auk and the "passenger-pigeon" to the California condor, give evidence how much this continent has been depleted as to its wild life. Many fishes, too, have decreased or wholly disappeared; and there is no doubt that, but for timely protection, many species, now small, would soon follow these vanished representa-

tives of the earlier fauna and swell the already lamentably long list of extinct animals.

On the high seas the reckless killing of larger animals goes on as relentlessly as on land. The great Cetaceans were abundant down both coasts when America was discovered. Since then the Biscayan whale, *Balaena glacialis*, the Greenland whale, *Balaena mysticetus*, and the much wilder *Balaenoptera physalis* have in turn been brought to the verge of extinction. No less the widely distributed "cachalot," *Physeter macrocephalus*; while a lengthening list of lesser marine forms is being rapidly hunted out. The greatest destruction has taken place since the invention of the "shot harpoon" by Sven Foyn (at first a sealer), about 1870. By that time owing to wildness and scarcity the older methods of whale capture were no longer capable of returning a profit. With the introduction of power launches few forms can now escape. The monetary loss resulting from this indiscriminate slaughter has been enormous. From 1835 to the wane of the fisheries about 1872, in 19,943 American voyages some 300,000 whales were captured, yielding oil and bone worth \$272,000,000. At the meeting of the American Association for the Advancement of Science in Chicago, 1907, a resolution was passed to aid "in any way practicable those measures legislative, international and local which will prevent the now imminent extermination of the great marine vertebrates, especially the cetaceans and manatees, seals, green and other turtles on the coasts of the United States, or on the high seas." (See EXTINCTION OF SPECIES). Consult Dawkins, Boyd, 'Cave Hunting' (London 1874); Bryden, 'Nature and Sport in South Africa' (ib. 1897); Dixon, 'Lost and Vanishing Birds' (ib. 1898); Buller, 'Birds of New Zealand' (2d ed., ib. 1888); Grieve, 'The Great Auk' (ib. 1885); Finn, 'Wild Animals of Yesterday and To-day' (ib. 1913); Harting, 'British Animals Extinct within Historic Times' (ib. 1880); Hutchinson, 'Extinct Monsters and Creatures of Other Days' (New York 1911); Lankester, 'Extinct Animals' (ib. 1905); Loomis, 'Hunting Extinct Animals in the Patagonian Pampas' (ib. 1913); Nathorst, 'Hafva djuren rättighet att leva' (Stockholm 1907); Newton, 'Dictionary of Birds' (ib. 1896); Rothschild, 'Extinct Birds' (London 1907); Wieland, 'Conservation of the Great Marine Vertebrates'. (*Pop. Sci. Month'y*, 1908); Wallace, 'Island Life' (London and New York 1880); 'Annual Report of the Smithsonian Institution for 1888' (Washington 1889).

Revised by G. R. WIELAND.

**EXTINCT RACES.** See MAN, PREHISTORIC RACES OF.

**EXTINCTION, Tribal.** Certain broader inferences as to the nature of arrested evolution and extinction of races or types, rather than the species, can be drawn only from a systematic examination of the geologic-paleontologic record. It is now clearly recognized that periodic emergence and subsidence of the continents has been going on as far back as the fossil records extend, with resultant biologic diastrophism. It is also recognized that the initial expansion or climacteric of groups mainly occurs soon after their first appearance.

As a consequence the inadaptive and unfit species are crowded out, not alone by those nearly of their own kind, but by the successful forms of other groups. Earth, sea, and air, as suggested, must tend to hold to some numerical mean of population. But the higher a group in the scale of organization, the more delicate is the adjustment to environment. Rapid adaptive change, like over-specialization, much increases liability to extinction by cataclysm. The relatively successful forms are swept away by renewed environmental disturbance if too rapid to neutralize by a further course of direct evolution, or by catagenetic change. For this reason alone the relative tenure of races as such is longest in the lower forms. The higher groups such as Limulids may show a remarkable persistence, or, like the Testudinata, a relatively long life; but "immortal types" are mainly inconspicuous like the Foraminifers. That such so often occupy abysmal oceanic or other zones least subject to change, sets a further visible boundary to the course of extinction. Still another is set by the fact that higher types also tend to persist in the zones and regions of least change—"asylums."

The inherent organic quality which as fixedly as gravity sets and holds evolution in its course was aptly termed by Cope "bathmism." This is the force that evolves, and also kills; but the bathmic causes of extinction are even harder to scan than are direct bathmic factors. Reduced to its simplest elements, life must be regarded as a property of matter, and plasm certainly exhibits in closed environments a high degree of stability. It may also exhibit characters little removed from those of strictly inorganic substances (Chunder-Bose); although wholly senescent or absolutely unchanging types are not theoretically indicated—that is, taking the entire duration of the rock succession as a time unit. However, when the common factors of change, bathmism (or ontogeny), environment, heredity and selection, are inactive, the organism shows little progression; and this indicates climatic change, taken in its very broadest sense, as the chief evolutionary stimulus. There is a further inference of primary value gained from the study of devolution or catagenesis as opposed to anagenesis. No races are exempt from the totality of climatic factors. The precision of the phenomena of plant succession would alone warrant this statement. It follows that while surprising modifications may take place when races decline, there is, during the anagenetic movement, a melior mean of form toward which all types strive—each according to its capacity, and in delicate adjustment to environment. Consequently the idea that lines of descent take the form of the "paleontologic tree," and lead back continually to main primitive stems, must as a rule express too much. A far simpler course of parallel development and parallel decline is indicated. As to when, in the course of this universal parallelism, direct evolution or ascendancy reached its high noon would at present be only a subject of speculation. But from a physical point of view there must be such a point of time, probably denoted by the appearance of persistent bipolar ice caps. Morphologically the appearance of the oak in the lowermost Cre-

taceous may denote the evolutionary crest. Beyond are palms and grasses.

**Bibliography.**—Patten, 'Evolution of Vertebrates and their Kin' (1912); Scott, W. B., 'History of Land Mammals on the Western Hemisphere' (1913); Wieland, 'American Fossil Cycads' (Vol. II, 1916); Clements, 'Plant Succession, an Analysis of the Development of Vegetation' (1916); Lull, 'Organic Evolution' (1917); Osborn, 'Origin and Evolution of Life' (1918); Ruedemann, 'The Paleontology of Arrested Evolution' (1918).

G. R. WIELAND,  
Yale University.

**EXTINCTION OF SPECIES.** The antithesis of evolution is extinction. Direct evolution leads by insensible degrees to replacement by changed descendants or to actual decadence and disappearance of types. Study of the phenomena of elimination sheds much light on the nature of life and the general evolutionary course. Also, the fossil record peculiarly lends itself to such a study, being so largely a record of extinctions.

The particular reasons for the extinction of animals and plants are not always obvious and may be very difficult of interpretation. Barring some factors to be mentioned later, the same variations of environment and most of the forces of selection considered as necessary to the production of new species are also powerful agents in the extermination of established forms. The history of many species may be compared to that of an individual. It has its birth, its growth, its decline, its death. Also, the laws of evolution show that many other species undergo modifications or changes which ultimately transgress or supplant the original assemblage of specific characters, so that a new species results by a process of mutation. Furthermore, many other species, while retaining their strictly specific characters, may be translated into different genera through modifications of their generic characters.

The continuance of a species depends upon its harmony with its environment. A perfectly stable and continuous environment is obviously a natural impossibility. The physical conditions of any region of the earth are in a state of constant change, sometimes very gradual and extending over long periods of time, sometimes sufficiently rapid to be measured by ordinary standards. The organic agencies surrounding any species are also not permanent; migrations are continually going on; the areas occupied by various organisms are being extended or reduced; periods of excessive or repressed fecundity often occur; there are times of abundance and scarcity of food, increase and diminution in the number of enemies, and so on. Any material change in the physical or organic environment must produce a readjustment among the individuals composing a species; their number may be lessened or increased, or they may be forced into conditions of life which produce changes in habits, place or abode, food, function, structure or organs.

The study of a geographic life-province shows that the organisms inhabiting it are in the state of a moving equilibrium. Minor changes in the physical conditions, as slight differences in temperature, moisture, elevations, etc., may be compensated for by a readjustment

among the organisms themselves. In some cases this readjustment may be favorable to many of the species, while in others it may initiate changes which ultimately result in extinction. More profound changes in the physical environment necessarily produce a greater effect upon the animals and plants, and may result in the extermination of many and the considerable modification of others, so that a distinctly transmuted fauna and flora would occupy the region.

The forces already mentioned, though operative to a greater or less degree, are not believed to affect so immediately the equilibrium of a species or the general equilibrium of a biotic province as the invasion of new species, either by extension, migration or evolution. The struggle for existence amid gradually changing physical conditions alone is not so aggressive as the invasion of a new assemblage of plants and animals; for in the former the struggle is the normal result of the physical and organic forces of an environment in which the adjustments have been made and an equilibrium reached; in the other there is the direct addition of a new set of opposing forces, requiring the immediate readjustment of both invading and invaded organisms.

A census of the animals and plants of any region will show a great variation in the number of individuals representing the various species. Some are abundant, some common, while others are rare. Now, since the normal impulse of the individuals of each species is to increase inordinately, the fact that some are of rare occurrence shows that forces are at work tending to check their multiplication, and the relative rarity of a species, as compared with others of the same genus, is taken as an indication of approaching extinction.

The development of spines, thorns, prickles or horns on animals and plants has been shown by the writer to represent an advanced stage of evolution within the type, as well as the degree of differentiation of the organism, the ratio of its adaptability to the environment and the measure of its vital power. The study of the life histories of spinose forms shows that they are simple and inornate during their young stages, and their phylogeny shows that they were all derived from non-spinous ancestors. It is further believed that spines represent an extreme of superficial differentiation which may become fixed in ontogeny, and also that spinosity represents a limit to morphological and physiological variation. Therefore, after attaining the limit of spine differentiation, spinose organisms leave no descendants, and out of spinose types no new types are developed.

The factors as above partly noted affecting the continuance or life of a species may be divided into two classes: (1) those residing within the individuals of a species itself (intrinsic), and (2) those extraneous to the species (extrinsic). The action of either the intrinsic or extrinsic factors tends to result either in extinction or in the mutation of a species into another form. In both cases a specific type disappears or is eliminated, although only in the first instance is the species exterminated in the sense that it has left no descendants. Within the limits of this article but little more than a descriptive statement of these principal factors can be attempted. It should also be borne in

mind that there is an overlapping and interdependency among the factors, causing them to react upon each other. Thus, an unfavorable environment due to change of climate may affect the food (extrinsic), which in turn may affect the vitality of the species, possibly resulting in degeneracy (intrinsic). Likewise, parasitism and disturbances in symbiotic relationships produce far-reaching, complex effects.

**Intrinsic Factors of Extinction.**—Under this head may be considered such factors as (1) lack of power of adaptation; (2) lack of vitality; (3) overspecialization; (4) old age (gerontic stage of evolution); (5) pathologic condition; (6) degeneracy; (7) inbreeding; (8) mutation. When a species cannot accommodate itself to changes of climate, food, etc., or in any way becomes fixed, it must perish unless it can find a suitable and constant environment—a physical impossibility. The waning vitality so plainly expressed by many species must be considered as evidence of approaching extinction. Such species usually occupy restricted geographic provinces, they are generally not numerically abundant, and their powers of reproduction are more or less retarded or repressed. An animal or plant which becomes so specialized that it can live only under certain peculiar conditions stands a chance of extermination whenever the harmony of these conditions is disturbed. Thus a plant which depends upon a certain species of insect for its fertilization will succumb if the insect seeks other food or is itself extirpated from any cause. Also, an animal depending solely upon a species of plant for food, or requiring a certain elevation or range of temperature for its continuance, will be exterminated when these are disturbed, unless it can adapt itself to the change. Specialization in general is manifested by the departure of organs or sets of organs from what is normal to the class. It results in the extreme differentiation of previous structures, or in their suppression, generally due to disuse or restraint, and also in a perversion of their original function. It has been shown by the study of many instances of extinct species preserved in the rocks of past geological periods, that each species has its period of birth, youth, maturity and old age, which often may be recognized by distinctive individual or numerical characters; so that whenever a species can be shown to possess what are known as gerontic or old-age characters it can be safely predicated that its extinction is near at hand. Pathologic characters in a species indicate the same conditions as disease in an individual, and point clearly toward extermination. Adverse conditions may affect the entire fauna and flora of a region, producing dwarfed, depauperate and pathologic species. Their history is usually very brief and their places are taken by organisms in accord with the environment. Retrogressive evolution indicates that the race has not only ceased to advance, but is declining. The history of any genetic line of species shows that whenever retrogressive characters appear and constitute dominant features the rapid decline and extinction of forms possessing them is imminent. The reduction of species numerically, and its restriction within narrow geographic limits, lead to inbreeding and the consequent impairment of virility. The small herds of European bison preserved by the Russian government in

the forests of Lithuania and the Caucasus are rapidly declining, both numerically and in vitality, due almost wholly, according to recent reports, to inbreeding. Each species now existent must have had an ancestor from which it has been derived through one or more of the many processes of evolution. Some of these ancestral types may be still living, while others are extinct. Going back to past geologic times (for example, to the Carboniferous) each species was derived by evolution from ancestral species. Both the ancestors and all the species once living in the Carboniferous are now extinct. Life, however, was continued on into the next age through modified descendants of a percentage of true Carboniferous species. The rest were exterminated and left no descendants. In the first instance it is extinction by mutation and in the second extinction by extermination. It seems probable that ever since the earth has been fully tenanted with a varied life there has been a fairly constant ratio at all times between the number of species just exterminated, the number of primary species originating by the mutation of ancestral forms, the number of species arising by the special differentiation of the primary species, and the number of species adapting themselves to the changes which are dominant during the succeeding geologic period.

**Extrinsic Factors.**—Agencies outside of the organism itself which in their operation may cause extermination of species may be grouped under the following heads: (1) Unfavorable physical environment; (2) changes affecting the food-supply; (3) preponderance of enemies; (4) the agency of man; (5) cataclysms. A physical environment which can properly be considered unfavorable must act on the individuals of a species in an adverse manner, and necessarily the result is deleterious to its continuance. The unfavorable characters of the environment may be various, as too high or too low temperatures, excessive moisture or dryness, unsuitable altitude, storms, winds, polluted and sediment-laden waters, etc., any of which if not normal to the requirements of the organisms will have a repressive effect on their growth and multiplication. The persistence of these inhibitory conditions will generally cause the speedy extinction of the species. The life of any organism is so dependent upon the stability of the food-supply that any change which seriously affects the kind and amount of food reacts immediately upon the species which rely upon it for sustenance. The extinction of a species from any cause involves either the extinction of the organisms dependent wholly upon it, or their adaptation to new conditions. Such of these as have lost their plasticity, either from high specialization or gerontic development, will perish. The invasion of any province by a new fauna or by a new flora or by both combined will initiate a struggle for supremacy of occupation which will drive out some species, exterminate others and modify still others. In these changes the food is an important element in determining the success or failure of a species to maintain itself. On the other hand, abundance of food leads to sluggish habits and tends to produce increase in size. In this way may be explained the prevalence of many large contemporaneous species of reptiles in the Mesozoic, and of large mam-

mals at different epochs in the Tertiary. This increase in size exposed them to increasing danger from starvation, from changes in climate and from competition with smaller active and more numerous animals. It is difficult to estimate how far in some cases the extinction of a species may have been due to the invasion of noxious bacteria or other parasitic organisms. It can only be predicated that their ravages are sometimes of such a nature that the ranks of a species are thinned out to the verge of extinction, and it is quite possible that actual extermination occasionally has occurred through this cause. Dr. Falconer believed that insect enemies have prevented the increase and extension of the elephant in India, and Darwin likewise stated that the increase of large quadrupeds in some parts of South America was prevented by insects and blood-sucking bats. It is doubtful, however, whether these agents were ever the primary and sole causes of the extinction of any large animal. The most vulnerable point of attack in the extermination of large animals is their young or their eggs. Animals of large size usually lay few eggs or bring forth very few young, and usually at infrequent intervals. The eggs or the young are easily destroyed by small creatures that would be powerless before the full-grown animals. The downfall of the great reptiles at the end of the Mesozoic has been explained by Morris as due (1) to the lack of care reptiles in general take of their eggs or young; (2) to the smaller number of eggs laid by the large species as compared with the smaller, whose continued existence in some measure is owing to their fecundity; and (3) to the progressive development of the mammals into egg-eating and predaceous placental forms of higher intelligence, at the close of the Mesozoic.

**Agency of Man.**—Man, being the dominant organism of the existing fauna and flora, has since his establishment had an increasing effect in the restriction and extension of contemporary plants and animals. As compared with the ordinary forces of nature, which in general work in an almost imperceptible manner when measured by human standards, man's influence has been incisive, profound and very rapid. He has been the only animal that has attempted to conquer nature in an intelligent manner for his own ends. Noxious animals and plants have been persistently attacked until many of them through reduction in numbers or by extinction have ceased to be a menace to his well-being. His inordinate greed has also led him to exterminate harmless useful animals by wholesale slaughter, chiefly because they offered little or no resistance, and also from a false notion that nature's resources are inexhaustible. (See **EXTINCT ANIMALS**). Along with man's conscious destruction of life, he has indirectly and without purpose accomplished the extermination of species to which he was wholly indifferent. This fact necessitates the division of this topic into two parts: (1) organisms directly exterminated by man, and (2) organisms indirectly exterminated by man. It is well known that the remains of early prehistoric man are found associated with the bones of extinct animals. Among these may be mentioned the mammoth, mastodon, cave-bear, cave-hyena, sabretoothed tiger, Irish elk, woolly rhinoceros, the giant birds of Madagascar and New Zealand,

and many others. While it is impossible to assert positively that their extermination was due wholly to man, yet undoubtedly man was one of the most powerful agents. Otherwise it is difficult to account for the disappearance of an animal from a continent that in some parts, at least, would furnish the proper climate and food for its continuous existence, from the time of primitive man down to the historic period. Even with the crudest of weapons, man with his superior cunning and intellect could successfully wage a war of extermination on such animals as the mammoth and mastodon by a method already mentioned; namely, that of killing the young.

Coming now to within the historical period, there are quite a number of well-authenticated cases of the extermination of species that can be traced directly to man as either the principal or sole agent. A few instances will be mentioned in this connection, and the list could be easily extended. Probably the best-known example of an animal exterminated by man is the dodo (q.v.), a large flightless bird related to the dove, formerly living on the island of Mauritius. Its clumsy helpless condition made it an easy prey, and the introduction of cats, dogs and pigs into the island hastened its extermination. On the islands of Rodriguez and Bourbon of the same group were found the solitaire (q.v.) and at least two other species of birds related to the dodo. They also soon disappeared after man's occupation of the islands. The great auk (q.v.) formerly ranged from the northeastern coast of the United States northward to the Arctic regions, and thence along the shores of northern Europe. It was at one time extremely abundant, but the last two individuals seen were taken near Iceland in 1844. The great northern sea-cow (q.v.) and Pallas cormorant, natives of the Commander Islands, became extinct near the close of the 18th century. The disappearance of the ure-ox from Europe is also well known. When the Bermudas were first settled in 1612, a food-bird known as the cahow bred in almost incredible numbers on several of the smaller islands. By 1616 it was almost exterminated, and a reference to the bird in 1629 states that it no longer existed. Singularly enough no remains of this bird were discovered until about 1913 when several cahow skeletons were found in the Bermudas by the naturalist, A. E. Verrill. The sickle-bill, a bird formerly used for making the royal robes in the Sandwich Islands, is now no longer living, having been hunted to extinction.

The introduction by man of various species of plants and animals into a region where they formerly did not exist has in some cases profoundly changed the native fauna and flora. A single well-authenticated illustration will suffice, though many more could be adduced. The island of Saint Helena was discovered about the year 1506, and at that time was densely covered with forests. In a little more than 300 years, fully five-sixths of the island had become entirely barren, and, as reported by Dr. Hooker, most of the existing vegetation was not indigenous but consisted of plants introduced from Europe, Africa, America and Australia. These exotic species, together with the goats, were carried to the island through the agency of man.

The goats destroyed the forests by eating the young plants, and the native vegetation could not compete in the struggle with the introduced species. It is estimated that 100 peculiar and indigenous species were extirpated in this manner, and all record of them is lost except a few species preserved in the Kew herbarium.

Besides the species already exterminated by man, it should be noted that many others were once abundant and widespread that are now reduced in numbers and restricted in range. Their final extinction seems to be a matter of a few years only. Among these may be mentioned the American buffalo, the fur-seal, the beaver, the elephant and the big-tree of California.

The violent catastrophes of nature seldom affect more than a very limited area of the globe, and species that are cosmopolitan or of wide geographic distribution would not be in danger of extermination. When, however, it is realized that some species are so restricted in their province as to occupy a single valley or a small island, then it is easy to believe that at rare intervals some great and sudden upheaval, subsidence, hurricane or volcanic outbreak may have destroyed all the individuals of certain localized species, if any such were within the area of disturbance. A West Indian hurricane in 1898 is believed to have totally destroyed a species of humming-bird peculiar to the island of Saint Vincent, though it is doubtful whether the great eruption of Krakatoa in 1883 and of Mont Pelée in 1902 exterminated a single species of animal or plant.

A review of the various causes of extermination shows that on account of their diversity and often extremely slow action it is difficult in any particular case to explain the total disappearance of a species unless a detailed knowledge can be obtained of the principal agencies affecting in any way the harmony of its surroundings or its ability to maintain its numbers in its natural province.

**Bibliography.**—Bailey, 'The Survival of the Unlike' (1896); Beecher, 'The Origin and Significance of Spines' (in the *American Journal of Science*, 1898); Cope, 'The Primary Factors of Organic Evolution' (1896); Cramp-ton, 'A Suggestion on Extinction' (in Proceedings of the Royal Physiological Society, Edinburgh, 1901); Darwin, 'Origin of Species' (1866) and 'Journal' (1872); Hutchinson, 'Extinct Monsters' (1892) and 'Creatures of Other Days' (1894); Lucas, 'Animals of the Past' (1901); Lyell, 'Principles of Geology' (10th ed. 1868); Morris, 'The Extinction of Species' (Proceedings of the Academy of Natural Science, Philadelphia, 1895); Topinard, 'Anthropology' (1878); Verrill, 'The Bermuda Islands' (Transactions of the Connecticut Academy of Arts and Sciences, 1901-02); Wallace, 'The Geographical Distribution of Animals' (1876).

CHARLES EMERSON BEECHER (1856-1904).  
Revised by G. R. Wieland.

**EXTORTION**, in general, the taking from another of something through illegal compulsion. It has been defined as a technical term of the common law to be "a crime committed by an officer of the law, who under color of his office corruptly and unlawfully takes any money or thing of value that is not due to him, or more than is due, or before it is due." At

common law, the offense is a misdemeanor punishable by fine and imprisonment, and subjecting the guilty person to removal from office. In the New York Penal Code extortion is defined as "the obtaining of property from another, with his consent, induced by a wrongful use of force or fear, or under cover of official right." Consult 'Encyclopædia of Pleading and Practice' (Vol. VIII, 23 vols., Northport, N. Y., 1894-1909).

**EXTRA-UTERINE GESTATION.** See PREGNANCY.

**EXTRACT**, a term to denote all that can be dissolved out of a substance by a specified menstruum, such as water, alcohol, ether, etc. In modern pharmacy the term is applied to two kinds of preparation from vegetables. One is obtained by digesting the plant in water or other solvent, and evaporating or distilling away the excess of solvent till the extracted matter is sufficiently inspissated. The other is obtained by bruising the plant in a mortar, separating the juice, warming it till the green coloring matter separates, and filtering it off. The juice is next heated till the albumen coagulates, and again filtered. The juice is now evaporated to a syrup, the green coloring matter added and well mixed, and the evaporation is thereafter continued till the required concentration is attained. Extracts must be capable of being redissolved, so as to form a solution like that from which they were derived. Extracts are used in cookery, medicine and the manufacture of perfumery.

**EXTRACT OF MEAT** is a soft, yellowish-brown, solid or very thick syrup, which is employed as a portable soup. It is now manufactured on the large scale by processes proposed by Liebig. Finely chopped flesh is exhausted with water, the extract is heated, when, at 133° F., albumen coagulates; afterward the blood coloring matter also separates, and when these are removed and the clear liquid is evaporated at a low temperature, the extract is ready. This substance has a characteristic odor of roast meat, has a strong taste, dissolves in water, and forms a not unpalatable soup, without, however, nutritive value. It contains no fibrin, gelatine, albumen or fat, but creatine, inosic acid and other organic bodies are present, and it is especially rich in potassic salts and in phosphoric acid. It has the invaluable property of not spoiling by keeping; and has been extensively used by travelers, explorers and by expeditionary forces. Consult 'Meat Extracts and Similar Preparations' in Bulletin 114, Bureau of Chemistry, United States Department of Agriculture.

**EXTRADITION** is the surrender of a criminal who has escaped from a territory under one government and taken refuge in a territory under another government. Extradition has two specific meanings in the United States. In the first place it refers to the surrender by one State government of a criminal who seeks asylum from another State of the Union in which he is held to be guilty of a heinous crime. (See EXTRADITION, INTERSTATE). In the second place, it refers to the surrender of a criminal by one nation to another. The demand for extradition made by one nation of another is a matter of international law, and implies merely

the control to be exercised by one nation over the right of affording asylum claimed by another. The Jay Treaty of 19 Nov. 1794 with Great Britain specified for powers of extradition during a period of 12 years. After its expiration in 1807 no provisions for international extradition were renewed until 1842 when the Ashburton treaty of 9 August of that year with Great Britain was concluded, in which extraditable offenses were enumerated. France on 9 November was the next country to enter into a treaty of extradition with the United States, since when treaties have been arranged with some 24 foreign governments providing for the mutual extradition of criminals, fugitives from justice, charged with heinous crimes, among which are enumerated robbery, burglary, arson, rape, embezzlement and the making and circulation of counterfeit money. In order to justify a claim for extradition, it is necessary to establish that the supreme political authority in the country where the crime has been committed has made a demand for the criminal's surrender; that an inquiry has been made into the facts of the case by a judge or United States commissioner, under direction of the President, in cases where the demand comes to the United States government from abroad; that a complaint be made on oath before the judge or commissioner; that a warrant be issued by the judge or commissioner for the apprehension of the party charged; that the charge be supported by suitable evidence; that a certificate be sent to the President of the United States signed by the commissioner, and stating that the charges are sufficiently well grounded to warrant a surrender; that such certificate so satisfy the President that he grant the writ of surrender.

The British extradition act of 1870 makes special provision that no criminal shall be surrendered for a political offense, and that the criminal shall not be tried for any but the crime of which he was demanded. In 1890 an extradition treaty was ratified between Great Britain and the United States extending somewhat the list of extraditable offenses in the direction of the commercial crimes of fraud and embezzlement. Consult Moore's 'Treatise on Extradition and Interstate Rendition' (1891); Clark, E., 'Treatise upon the Law of Extradition' (1904); Biron and Chambers, 'Law Practice of Extradition' (1903); Hawley, 'Interstate Extraditions' (1890); Spear, 'Law of Extraditions, International and Interstate' (1884).

**EXTRADITION, Interstate.** The New England Confederation of 1643 provided for mutual extradition of criminals between the different provinces; the Articles of Confederation did likewise; and the Constitution provides for it between the States, which are independent countries in all save the functions they have resigned to the general government. But the wording of the provision, though as definite as it can safely be made, leaves room for the widest difference in construction, and the evasion of the mandate in a large share of the cases that arise. It is: "A person charged in any State with treason, felony, or other crime, who shall flee from justice and be found in another State, shall, on demand of the executive authority of the State from which he fled, be delivered up, to be removed to the State having

jurisdiction of the crime." But must the offense be a crime by the law of the State requisitioned as well as of the State demanding? The judicial decisions say decidedly no—that "the obligation to surrender the fugitive . . . is the same as if the alleged act was a crime by the laws of both." On the other hand, the State executives, for obvious reasons, have stubbornly refused to tie their hands from exercising discretion, and have again and again acted on the theory that the offense must be a crime by the law of their own State. Thus, in the Dorr Rebellion (q.v.), Governor Cleveland of Connecticut refused to extradite Dorr—though Dorr was actually using Connecticut soil to organize an attack on Rhode Island—on the ground that the latter's treason laws were not valid outside itself; and Governor Seward of New York refused to surrender persons charged with stealing slaves (though his predecessors had done so), on the ground that it was not a crime by New York law, by common law or the common consent of civilized nations. Even the principles of decision are not agreed upon. In some States the courts hold that the courts of the State making the demand are entitled to decide as to the sufficiency of the cause; in others their own courts make their own law without regard to that of the other States. Still another question is, whether the governor has any discretion in the matter, supposing his State law to demand extradition. The answer is somewhat startling; it is, that the governor legally has no discretion, that he is imperatively bound to issue the warrant, but if he does refuse, there is no power to compel him and no punishment for the refusal. The Constitution, in other words, has issued an imperative mandate with no provision for its enforcement. Indeed, it is difficult to see how there could be any; the only remedy being a State impeachment of its executive for malfeasance, which is out of the question in such cases. The forms of interstate extradition are provided in the act of 1793. The accused must be indicted in the State where the offense is committed; if the magistrate before whom the charge is brought is satisfied of its truth, he issues a warrant for the arrest of the criminal, and a copy is forwarded to the executive of the State, who makes requisition for the fugitive's surrender on the executive of the State to which he has fled. If the latter is satisfied of the legality of the process and the sufficiency of the evidence of guilt, he is to issue a warrant for surrender; but habeas corpus proceedings may always be interposed. The expense of the proceedings and transportation is borne by the State making the demand.

**EXTRAORDINARY RAY.** See LIGHT.

**EXTRATERRITORIALITY**, in international law, the privilege granted to citizens of foreign powers of being exempt from the laws of the land of their abode and, in general, of enjoying the rights and privileges of their country of origin. In general, the right to exercise state authority and state law is limited to the territory of the state in question and a strict limitation of this view would place all persons within a state under the laws of that state, to the exclusion of all other laws. In the common intercourse between nations and peoples there have grown up certain well-rec-

ognized and clearly-defined exceptions to the exclusive exercise of state authority. These exceptions are in favor of sovereigns or heads of foreign states, their official representatives, officials performing certain duties by authority of a foreign state and with the consent of the state in which they operate, public vessels and their crews, citizens of Europe or America in certain Oriental countries, and public armed forces passing through a foreign territory. Extraterritoriality is the ordinary term used to designate the immunity from local jurisdiction enjoyed by these classes, such immunity varying according to the official character, or according to the state. Immunities are customary when granted to certain official personages in any foreign state and conventional in the case of other persons, whose treatment is regulated by agreement.

The head of a foreign state is accorded complete exemption from local jurisdiction. His person is inviolable, nor is he liable to any laws. His suite are accorded equal privileges. Should he or members of his suite abuse these privileges the remedy is to request him or them to leave the country, or to expel them in extreme cases.

Official representatives of a foreign state, such as ambassadors, are granted immunities similar to those accorded the head of their state, are inviolable, exempt from civil and criminal jurisdiction, enjoy freedom of worship, right of asylum and jurisdiction over their official personnel.

Consuls are usually granted such immunity as enables them to perform their functions, including limited exemption from taxation, exemption from military service and jury duty, inviolability of office and archives.

Public vessels, when in the territorial waters of another state, are subject only to the necessary harbor regulations for safety, anchorage, etc. The personnel are exempt from local jurisdiction while in the performance of their duties.

Citizens of European and American states have been granted special exemptions in certain Asiatic countries. Turkey after 1535 granted almost total exemption from local jurisdiction to citizens of France and other European powers. (See CAPITULATIONS, TURKISH). In other states of non-European civilization, such as China, Persia, Siam, Morocco and Japan, the same principles were applied as to Turkey. In 1899 Japan became a member in full of the family of nations when extraterritorial rights other than those of officials were abolished. In non-European countries several of the European states have developed elaborate judicial systems with jurisdiction over the persons and places exempt from local jurisdiction. (See INTERNATIONAL LAW; NATIONALITY; SOVEREIGNTY). Consult Moore, J. B., 'Digest of International Law' (1906); McLaughlin and Hart, 'Cyclopedia of American Government' (New York 1914).

**EXTRAVAGANTES**, two collections of decretals and constitutions of popes which were made up subsequent to 1317. Before the *Extravagantes* the Canon Law comprised the *Decretum* of Gratian (about 1150), the *Liber Sextus* (1298), the *Clementina* (1317) and several other official collections of papal decretals. No further collections were made by papal com-



mand, nor were any further collections officially promulgated; nevertheless, two collections were made by jurists, the *Extravagantes* of John XXII and the *Extravagantes Communes*; and these, though lacking official promulgation, came in time to be recognized as part of the Canon Law. The *Extravagantes* of John XXII consist of constitutions of that Pope only; the *E. Communes* comprise decretals of several popes between 1281 and 1484. The *Extravagantes* are so called because they wander out beyond (*extravagantur*) the limits of previous collections. Consult Bickell, J. W., 'Über die Entstehung und den Heutigen Gebrauch der Beiden. Extravagantensammlungen des Corpus Juris Canonici' (Marburg 1825).

**EXTRAVAGANZA**, *ëks-träv-a-gän'za*, in music and the drama, a species of composition designed to produce effect by its wild irregularity and incoherence; differing from a burlesque in being an original composition and not a mere travesty. See **DRAMA**; **STAGE**.

**EXTRAVASATION**, in contusions and other accidents, occurs when blood vessels are ruptured by the injury and the blood finds its way into the neighboring tissues. A good illustration may be found in an ordinary bruise, when the part becomes blue in consequence of the vessels having been ruptured and blood having escaped into the tissues. Extravasation in the cranium is a most serious accident, as the pressure on the brain which is the result often produces death very rapidly. The term is, however, applied to the escape of any fluid into the tissues from the vessels or cavity containing it.

**EXTREME UNCTION**, a sacrament of the Roman Catholic Church for the bodily and spiritual comfort of the sick whose death is deemed to be imminent. The words of the apostle Saint James in his epistle, ch. v, 14, 15, "Is any among you sick," etc., are interpreted as relating to this sacrament. The unction therefore is administered to the sick and to those only who are in danger of death from sickness or from injury or accident; hence, it is not administered to persons under sentence of death, nor to those about to undergo a dangerous surgical operation, or the like; nor to persons bereft of their reason; neither is it administered to children who have not reached the age of reason; for the principal end of this sacrament is, not restoration of bodily health, but forgiveness of sins. "If he has committed sins they shall be forgiven him." In the passage from Saint James are found all the essential conditions of a sacrament, namely, the "outward sign," to wit: the anointing and the prayer of faith; and the "inward grace," typified by the outward sign, namely, forgiveness of sins. The divine institution of this sacrament is implied in the words of the epistle of Saint James where it recommends its use and declares its efficacy for the remission of sins. Nevertheless extreme unction is not administered save after the person has made confession of his sins and received absolution in the sacrament of penance. In administering extreme unction the priest performing the ceremony must use olive oil that has been consecrated by the bishop; he dips the thumb of his right hand into it and, by marking them with the sign of the cross, anoints the organs of the five senses, pronouncing at each anointing the

words, "By this holy unction and by his most tender mercy may the Lord forgive thee whatsoever sin thou hast committed by sight" (*per visum*), or "by hearing" (*per auditum*), etc. The origin and history of extreme unction have been subjects of extended and violent discussion and, as a result, a large controversial literature has come into existence. Extreme unction was practised in the early Church, but not until the 11th century was it called a sacrament. Such it was decreed by Pope Eugenius IV at the Council of Florence (A.D. 1439). Its ceremonial, etc., was definitely established by the Council of Trent (A.D. 1551). The English Lutheran and other evangelical churches do not admit the contention that it is a sacrament. The Greek Church includes it among its sacraments; the application, however, differs in some respect from that practised by the Roman Church and is not limited to cases of supposed mortal illness. (See **SACRAMENTS**). Consult Buckley, T. A., transl., 'The Catechism of the Council of Trent' (London 1852); Puller, F. W., 'The Anointing of the Sick in Scripture and Tradition' (London 1904); Toner, P. J., 'Extreme Unction' (in 'The Catholic Encyclopedia,' Vol. V, New York 1909).

**EXTRUSION**. See **VOLCANISM**; and section on *Volcanism* in article on **GEOLOGY**.

**EXUMA**, *ëks-oo'mä*, Great and Little, two of the Bahama Islands. The Great Exuma is 30 miles long and 3 miles wide and has a good harbor. Little Exuma has also a good harbor. The two islands together with Exuma Keys have an area of about 150 square miles. Pop. 3,465.

**EYAS**, *fäs*, in falconry (q.v.), a hawk reared from the nest.

**EYB**, *ib*, Albrecht von, German author: b. Franconia 1420; d. 1475. He was educated at Pavia and was made archdeacon of Würzburg at the age of 29. He afterward was in the service of Pius II. In 1472 appeared his 'Ehstandsbuch,' a work on marriage, of which there have been frequent reprints. A recent edition is that of Hermann (Berlin 1890). Consult Hermann, 'Albrecht von Eyb und die Frühzeit des deutschen Humanismus' (1893).

**EYCK**, *ik*, Hubert van, Flemish painter: b. Maaseyck near Liège, Belgium, 1365; d. Ghent, 18 Sept. 1426. It has been claimed that he and his brother Jan were the inventors of oil painting. For transparent and brilliant coloring and minute finish their works have never been surpassed. Their masterpieces are for the most part in Ghent, Bruges, Antwerp, Berlin, Munich and Paris. The only painting that can now certainly be assigned to Hubert is the altarpiece with folding doors, 'The Adoration of the Lamb,' begun by him and finished by Jan, and afterward presented to the cathedral of Saint Bavon, Ghent, where only the two central divisions now remain, the wings being in the gallery at Berlin, with the exception of those representing Adam and Eve, which are in the Brussels Museum. The number of authentic works painted by the brothers is 24, but the number of attributions at auctions between 1662 and 1912 is over 400. Consult Weale, 'John and Hubert Van Eyck' (1908 and 1912).

**EYCK**, Jan van (also called Jan van Brugge, or John of Bruges), Flemish painter:

b. Maaseyck about 1381; d. Bruges, 9 July 1441. Hubert (q.v.) gave him his first instruction in the principles of the art, and his talents were so rapidly and vigorously developed that he soon surpassed his brother. The two resided at Bruges, then much frequented by the noble and the wealthy on account of its flourishing commerce. About 1420, or soon after, they went to Ghent for a considerable time, to execute together a work which Jodocus Vydt, a Flemish noble, had engaged them to do. This is the celebrated 'Adoration of the Lamb' for the cathedral of Ghent; a painting which contains above 300 figures, and is a masterpiece. It is painted on wood, with side panels which contain the portraits of the two artists and also of their sister Margaret, who it is now believed never had a corporeal existence.

The reputation of this celebrated painter became very notable, even during his lifetime, by his great share in the introduction of oil painting; the original invention of which has been incorrectly ascribed to him by many. It was a general custom, before his time, to have for the background of the picture a flat gold ground, from which the figure stood out without perspective, as may still be seen in numberless works of earlier date. Van Eyck followed this practice in his earlier efforts, but, as he made further advances in his art, conceived the idea toward which there had been hitherto only some distant advances of giving a more natural grouping and perspective to his figures by a natural background. In this he succeeded so eminently, as many of his still remaining works prove, that he may be called in this respect the father of modern painting, since he gave the art a new turn and impulse, and laid the foundation of that high degree of improvement which it afterward attained in the brightest era of the great masters who succeeded him in the Netherlands and in Italy. In the art of painting on glass he is considered as the author of the mode of painting with colors delicately blended and yet so firmly fixed that obliteration was impossible—an object before attained only by joining together (in mosaic) several small panes of different colors. The school of which he was, in some measure, the founder, does not yield in celebrity to the best contemporary or succeeding artists, although it must be allowed to be often defective in the representation of the extremities of the human body—a fault occasioned by that excessive delicacy which prevented the study of naked forms, and of anatomy in general. On the other hand, the face, dresses, grouping, distribution of light and shade are always superior, and the color brilliant and splendid, in the works of the painter and most of his scholars. Many of his paintings are still preserved, either in churches and museums, or in private collections.

**EYDE, Samuel**, Norwegian chemist and inventor: b. Arendal 1866. He was educated in his native country and also in Berlin. He was a practising engineer in Norway, Sweden and Germany. With Dr. Christian Birkeland of Christiania, he set about producing fertilizers from the air (nitrogen) and limestone by electricity. After a long experimental stage the idea was reduced to practice in 1903, when they began to manufacture the fertilizer with three men and a small motor. Within the following 10 years Eyde had plants aggregating 200,000

horse power, employed 400 chemists, engineers, etc., and about 14,000 other employees. The output of his works reached 2,000 barrels of Norway saltpetre per day. In 1914 he acquired another plant with 200,000 horse power. Notodden, Saaheim and Eydehavn are now towns supported entirely by these new industries. The war of 1914 hindered development along the lines mapped out by Eyde but gave a great impetus to the manufacture of explosives to which much of the capacity of the plants was diverted as early as May 1915.

**EYE**, the peripheral organ of vision. It receives light-energy, transforming it into nerve stimulus, which latter is transferred to the brain by means of nerve fibres.

**Anatomy and Physiology.**—The human eye has in general a spherical form, with a segment of a smaller sphere superadded anteriorly. The average antero posterior diameter is 24.26 mm.; transverse diameter 23.7 mm. The eyeball of a man is slightly larger than that of a woman. The middle point of the cornea is called the anterior pole, diametrically opposite to which on the sclera is the posterior pole. The line of union between the two poles is the geometric axis. The equator of the eye is a circle equidistant from the poles. (Fig. 1).

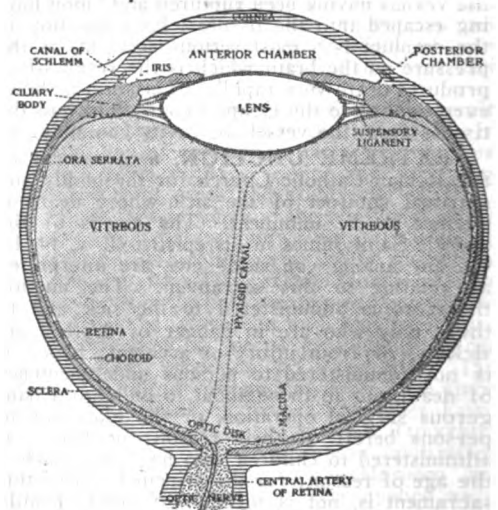

FIG. 1.—Horizontal section of the eyeball.

A shallow, circular furrow (sulcus sclerae externus), filled out with conjunctiva, separates the transparent cornea from the opaque sclera. The cornea is elliptical in shape, the horizontal diameter of 12 mm. being slightly greater than the vertical diameter. Between the margin of the cornea and the equator are the insertion lines of the recti muscles. (Fig. 2).

Posteriorly the optic nerve, with its sheaths, forms a cord, 5 mm. in diameter. Around the nerve some 20 arteries (short posterior ciliary arteries) enter the sclera to supply the chorioid. (Fig. 6). On either side of the nerve, in the horizontal meridian, the long posterior ciliary artery with its nerve pierces the sclera and enters the perichorioid space. The posterior part of the globe has been called the arterial half, because here nearly all the nutrient blood enters the eyeball. The venous

blood leaves by way of the *venae vorticosæ*—two superior and two inferior, just behind the equator. (Fig. 3).

The eye is composed of a variety of tissues, and is divided into three main zones according to its development. The posterior zone, the largest, extends from the entrance of the optic nerve to the insertion lines of the recti muscles. Here begins the middle zone, the anterior limits of which are marked by the *sulcus scleræ externus*. The narrow anterior zone embraces cornea and iris. The cornea and sclera make up the firm, fibrous capsule of the eye, lending form and shape and protecting the delicate inner layers from injury.

There are four principal coats to the eyeball, i.e., (1) sclera and cornea (fibrous capsule); (2) chorioid (vascular layer); (3) pigment epithelium; (4) retina. (Fig. 7). In the posterior zone all four coats are easily separated from one another. In the middle zone the sclera undergoes no change, but the other three coats are transformed into one organ, the ciliary body. In the anterior zone the sclera becomes differentiated into the cornea; while elements from the chorioid, pigment epithelium and retina form the iris.

The contents of the eyeball are the vitreous, the lens and the aqueous. In that part of the eye occupied by the aqueous the iris is suspended, dividing it into an anterior and a posterior chamber. (Fig. 1).

On its inner surface the sclera is separated from the chorioid and ciliary body by the perichorioid space. All the blood vessels and nerves supplying the uvea (that is chorioid, ciliary body and iris) pass through the sclera in canals—*emissaria*. The sclera is divided into three layers—*episclera*, containing blood vessels of its own and having more loosely arranged bundles; *sclera proper*, with its dense texture and the absence of vessels, and the *lamina fusca*, characterized by the appearance of chromatophores—branched connective tissue cells, containing pigment granules. (Fig. 7). In general, the scleral tissue is that of a tendon. In the sclera the bundles run in every direction, while in a tendon the bundles are parallel with one another. The fixed cells lie between the bundles. Posteriorly the sclera is continuous with the sheath of the optic nerve; anteriorly it goes over into the cornea. (Fig. 1). The narrow zone of transition between the cornea and sclera is spoken of as the *limbus*.

The cornea occupies about one-sixth of the circumference of the eyeball. (Fig. 1). It contains no blood vessels, but is nourished by lymph from loops of blood vessels adjoining it. The cornea is strongly curved, and has a weak refractive power because it is thinner in the centre than at the periphery. It has five layers (from without inward)—(1) Epithelium; (2) Bowman's Membrane; (3) Stroma; (4) Descemet's Membrane; (5) Endothelium.

The epithelium of the cornea is a stratified pavement epithelium of some five or six layers. The basal cells lying on Bowman's membrane are tall cylindrical cells. In the second layer the cells become rather cuboid in shape. From the third layer on they grow flatter, until those of the surface layer are exceedingly flat. The superficial flat cells present a perfectly smooth and even surface, giving the cornea its brilliancy and lustre. Between the epithelial cells

are minute nerve endings, endowing the cornea with exquisite sensibility. Bowman's membrane contains no nuclei. It has a smooth anterior surface, while posteriorly it merges with the stroma, of which it is considered a modified part.

The Stroma—*substantia propria*—comprises about 90 per cent of the cornea. It is made up of connective tissue lamellæ, running

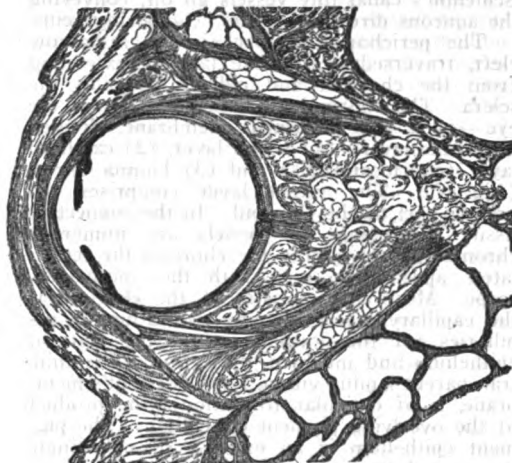

FIG. 2.

in all directions. Between the lamellæ are the fixed corneal cells. Leucocytes wander into the cornea, and into the epithelial layers, and are called wandering cells, in contradistinction to the fixed cells. The stroma is covered on its posterior surface by the homogeneous, elastic membrane of Descemet. This is a true membrane having two sharply defined contours. It is of cuticular formation, being the product of the

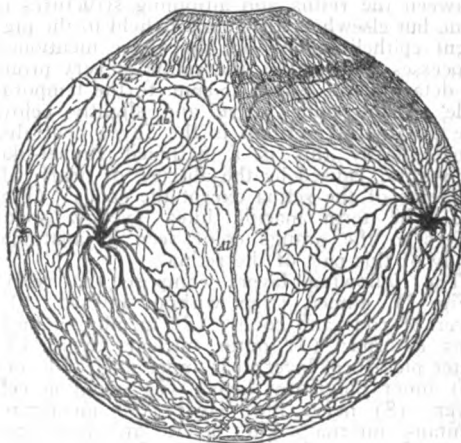

FIG. 3.

underlying endothelium. It increases in thickness with age. A single layer of endothelial cells lines not only Descemet's membrane but extends over the trabeculæ at the angle of the anterior chamber onto the anterior surface of the iris.

Opposite the external scleral furrow, on the internal surface of the fibrous coat of the eye, is another circular depression—*sulcus scleræ*

internus. This is partly filled by a loose meshwork, triangular in shape, going over from the cornea to the iris. To the scleral side of the meshwork one finds an irregular lumen—the canal of Schlemm. (Fig. 1). This lies protected in the sclera on all sides, except its inner wall which comes in contact with the aqueous. The aqueous finds its way into the canal by a process of filtration. On the scleral side of Schlemm's canal tiny vessels go off, conveying the aqueous directly into the neighboring veins.

The perichorioid space is but a narrow cleft, traversed by delicate lamellæ extending from the chorioid and ciliary body to the sclera. The chorioidea—vascular layer of the eye—is a thin brownish membrane, divided into three layers, (1) vessel layer, (2) capillary layer (choriocapillaris) and (3) lamina vitrea. (Fig. 7). The vessel layer comprises the greater part of the chorioid. In the connective tissue supporting the vessels are numerous chromatophores, giving the chorioid the tessellated appearance seen with the ophthalmoscope. Most characteristic of the chorioid is the capillary layer, forming a stratum of capillaries for the nourishment of the pigment epithelium and much of the retina. The thin, transparent lamina vitrea, like Descemet's membrane, is of cuticular formation—the product of the overlying pigment epithelium. The pigment epithelium is an expanse of one single layer of hexagonal cells, present everywhere from the optic nerve to the pupillary margin. Each hexagonal cell gives off a number of processes which project inward among the rods and cones.

The retina (Fig. 7), fourth of the principal layers of the eyeball, is a soft transparent membrane, extending from the optic nerve to its jagged anterior margins—the ora serrata—opposite the insertion of the recti muscles. At the anterior and posterior margins the union between the retina and adjoining structures is firm, but elsewhere the retina is held to the pigment epithelium only by the above mentioned processes. Therefore, the retina is very prone to detachment. Some 3.5 mm. to the temporal side of the optic nerve and slightly below the horizontal meridian is the fovea centralis. Anatomically this is a flattened funnel-like depression, caused by the absence of nearly all elements of the retina except the cones. (Fig. 1). The term *macula lutea* (yellow spot) refers to the orange color seen in anatomic study of this part of the retina.

The following layers compose the retina (Fig. 7), named from without inward; (1) layer of rods and cones; (2) *membrana limitans externa*; (3) outer nuclear layer; (4) outer plexiform layer; (5) inner nuclear layer; (6) inner plexiform layer; (7) ganglion cell layer; (8) nerve fibre layer; (9) *membrana limitans interna*. The layers are connected partly by extensions from the individual elements and partly by a supporting framework—the fibres of Mueller.

The rods are cylindrical structures; the cones flask-shape. Both possess a thinner outer half and a thicker inner part. The rods contain the visual purple, which bleaches out readily in the cadaver but regenerates in the dark when the relationship to the pigment epithelium is undisturbed. The cones are found in all parts of the retina; in the fovea

there are no rods. The *membrana limitans externa* is a very delicate sieve-like membrane, having a perforation through which each rod and cone sends a prolongation to its own nucleus in the outer nuclear layer. The outer plexiform layer is essentially a supporting layer, composed of proximal portions of rods and cones on the one side and of fine extensions from the inner nuclear layer of the other side. The inner nuclear layer contains the nuclei of Mueller's fibres and nerve cells. There are also larger cells in this layer provided with Nissl's granules. The sixth layer, inner plexiform layer, resembles the outer plexiform layer and belongs to the supporting tissue. The ganglion cells of the next layer are multipolar and send off numerous dendritic processes into the underlying inner plexiform layer. The nerve-fibre layer, with its neuroglia cells, is composed of afferent and efferent fibres passing to and from the optic nerve. In this layer the larger vessels of the retina are lodged. Finally, the very thin glass membrane—*membrana limitans interna*—separates the nerve-fibre layer from the vitreous.

The retina is composed of three neurons, or nervous units, named as follows in the sense of their conduction. The rods and cones, with the outer nuclei, belong to the first neuron. This unit serves for the reception of the individual light impressions. The nerve cells among the inner nuclei form the second unit. These cells come in contact with elements from the first and third neurons. The latter is represented by the ganglion cells, the axis cylinders of which reach through the optic nerve, the chiasm, and optic tract to the brain.

The rods and cones, outer nuclear layer and part of the outer plexiform layer are nourished by the chorio-capillaris. All the other layers have a vessel system of their own in branches of the *arteria centralis retinae* and veins of the same name. The blood vessels are the only elements in the retina of mesodermic origin; all else is derived from the ectoderm. In the peripheral portions of many eyes one encounters peculiar cavities due to cystoid degeneration. These are the spaces of Lessing or Ivanoff's retinal oedema.

The optic nerve (second cranial) unites the retina to the brain. (Fig. 2). That portion of the nerve lying within the wall of the eye is termed *bulbar* or *intraocular*. The orbital or *retrobulbar* portion lies between the eyeball and the *canalis opticus*. Another division is into a medullated and non-medullated portion. At the *lamina cribrosa* the medullary sheaths cease; in consequence the nerve-fibre layer of the retina has no sheaths of Schwann, and is transparent. The cord is surrounded by three sheaths; outer, *dura mater*; middle *arachnoid*; and inner, *pia mater*—all continuous with the membranes of the brain. Between the *dura* and the *pia* is the *intervaginal space*. This is divided by the *arachnoid* into two cavities, an outer, *subdural*, and an inner, *subarachnoid*. Both communicate with spaces of the same name in the cranium. The *pia mater* closely invests the nerve substance sending numerous *trabeculae* among the nerve-fibres and separating them into incomplete bundles. About 20 mm. behind the eyeball the central artery and vein of the retina enter the nerve at right angles and continue in its axis to the retina.

They are surrounded by connective tissue carried in with them from the pia mater. The nervous element is composed of extremely numerous fibres estimated at half a million or more, with its own supporting framework the glial cells. The lamina cribrosa is the perforated space in the sclera for the entrance of the nerve fibres.

The circular area in the inner opening of the optic nerve canal, corresponding to the area of the lamina cribrosa, is called the disc or papilla. This space, consisting of conducting fibres only, receives no impressions, and is known as Mariotte's blind spot. The cupping or hollowing of the disc may be physiological, or pathological as in glaucoma. An arterial ring—Circle of Zinn—surrounds the optic nerve entrance into the sclera.

The ciliary body, with a breadth of 5 or 6 mm., forms a girdle around the eyeball, corresponding to the middle zone. It is divided into a flat, broader posterior part—orbiculus ciliaris—which is succeeded anteriorly by a system of some 70 processes—corona ciliaris. Between the ciliary processes are the ciliary valleys.

In the equatorial region, in the suprachoroidal lamellae smooth muscle fibres make their appearance, developing anteriorly into the ciliary muscle—or muscle of accommodation. The outer bundles of the muscle run in a meridional direction. This is replaced inwardly by a system of circular bundles—Mueller's muscle. In myopia the meridional bundles are more developed; in hyperopia the circular bundles.

A layer of blood vessels covers the inner surface of the muscle, being a direct continuation of the chorioid. Over this vascular layer the lamina vitrea of the chorioid and the pigment epithelium spread out. The inner surface of the ciliary body is lined by a single layer of epithelium—which represents the retina. This ciliary epithelium is everywhere very uneven, due to tiny elevations and depressions to which it clings—the whole arrangement forming the reticulum of Heinrich Mueller. Lastly, the membrana limitans interna comes forward to clothe the ciliary epithelium, just as it clothes the retina posteriorly. The ciliary epithelium secretes the aqueous and has largely to do with the nourishment of the lens and vitreous.

The iris has its insertion on the anterior surface of the ciliary body. (Fig. 1). Severed from connections it has the form of a circular plate—like the diaphragm in optical instruments. The outer margin is the ciliary border. The circular opening in the middle is the pupil. This latter is located slightly to the nasal side. The anterior surface is divided by a zig-zag line 1.5 mm. from the pupillary margin, into an inner, pupillary zone, and an outer ciliary zone. Trabeculae of connective tissue containing vessels traverse the iris, converging toward the centre, like the spokes in a wheel. Depressions between the trabeculae are termed crypts. In the ciliary zone running circularly are the contraction furrows, corresponding to the creases in the palm of the hand. The lesser arterial circle of the iris is situated under the zig-zag line. It is formed by an anastomosis from the radiating vessels which enter the root of the iris. These radiating vessels are derived from the greater arterial circle of the iris, which is

located in the vascular layer of the ciliary body. (Fig. 3). The greater arterial circle is in turn derived from an anastomosis of branches from the two long posterior ciliary arteries. When the stroma is delicate the sphincter muscle may be seen as a whitish band, 1 mm. in width, immediately adjoining the pupillary margin.

The stroma bearing the blood vessels and comprising the bulk of the iris is a continuation of the chorioid, by way of the vascular layer of the ciliary body. The pigment epithelium remains the same; while the ciliary epithelium takes on pigment; so that the structures posterior to the iris are protected from the light by two strata of highly pigmented cells. The sphincter and the dilator muscles are of ectodermic origin formed by a differentiation of the pigment epithelium. Other muscles of the body are of mesodermic origin. The posterior surface of the iris has a very delicate system of radiating and circular markings.

The iris varies greatly in individuals. When the stroma is loose and sparse and contains few chromatophores the result is the blue iris, because the black pigment epithelium through the delicate veil anteriorly appears bluish—the blue eye. When the stroma is heavy and the chromatophores numerous we have the brown iris,— here the chromatophores determining the color. Aside from the color, there is, therefore, an anatomical difference—the blue iris being the light thin one; the brown iris the heavy thick one.

Vitreous, corpus vitreum, is a transparent jelly-like substance consisting of an exceedingly delicate meshwork, the interstices of which are filled out by fluid. It has the transparency of water—may be felt in a basin of water but not seen. It contains no blood vessels, no nerves, and depends for its nourishment on adjoining structures, principally the ciliary body. A canal beginning at the front of the papilla extends to the lens—Cloquet's canal. The fibrillae making up the stroma of the vitreous have their origin just anterior to the ora serrata, on the orbicularis ciliaris. Diseases of the ciliary body readily affect the vitreous.

The crystalline lens lies in a della—fossa patellaris—on the anterior surface of the vitreous. (Fig. 1). It is a transparent body, having the shape of a biconvex lens. The centre of the anterior surface is designated the anterior pole, a similar point on the posterior surface of the posterior pole. The lens capsule is a typical glass membrane, like that of Descemet or the lamina vitrea of the chorioid. Lining the inner surface of the anterior capsule is a layer of cuboid epithelial cells. At the equator of the lens these elongate to form the lens fibres. Those layers of the lens substance next to the capsule comprise the cortex. At the centre is a harder, denser mass, the nucleus. The lens grows larger throughout life to make room for the ever-increasing number of lens fibres within its body.

Posteriorly the lens is held to the anterior border layer of the vitreous by a firm union in the shape of a ring—Ligamentum hyaloideo capsulare. The zonular fibres are the main support of the lens. They are structureless, non-nucleated fibres, clear as glass. They are firmly attached to the ciliary body on the one side and to the anterior and posterior surface

of the lens, near the equator, on the other side. (Fig. 1).

The cornea and lens are the media of the eye principally concerned in the transmission of light to the retina and in the formation of images upon it. The rays of light striking the cornea are refracted to pass through the pupil. The lens now brings them to a focus on the retina, producing an inverted image. The lens by the action of the ciliary body adjusts itself to focusing objects at different distances—accommodation. When the ciliary muscle con-

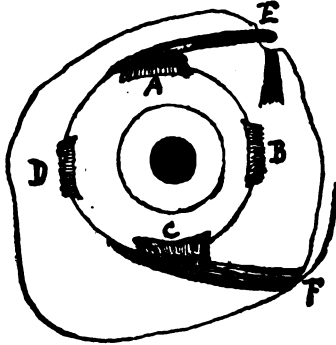

FIG. 4.

tracts the lens increases its convexity and shortens its focus, as in the act of reading. At about 45 years of age the lens, owing to the sclerosis of its fibres, begins to lose its elasticity. This is the condition of presbyopia—old sight. In myopia the focal image is formed in front of the retina, usually due to too great length of the antero-posterior diameter of the globe. In hyperopia the eyeball is too short. Astigmatism is the condition in which the rays of light do not converge to a point on the retina. It is ordinarily due to inequality of curvature of the cornea (or lens).

By the field of vision we mean the space in which one can see, while steadily gazing at a point in the direct line of vision. The field does not extend regularly in all directions. It

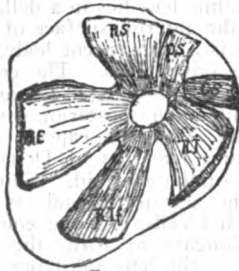

FIG. 5.

reaches farthest toward the external side, where it extends over 90°. The field for colors grows smaller in the following order: blue, red and green. Defects in the visual field are termed scotomata.

The orbit is the pyramidal cavity in which the globe lies. Its walls are formed by seven bones of the face; namely, frontal, sphenoid, ethmoid, nasal, lacrimal, superior maxillary, and palate bones. These bony walls separate the orbit from the following cavities: the intracranial, the frontal, the nasal, and the

antrum of Highmore. Diseases of the sinuses frequently involve the orbit. The anterior opening of the orbit is its base. Here the walls become thickened into a strong bony rim—margin of the orbit—to defend the eyeball against injury. At the upper margin of the orbit is the supra-orbital notch for the passage of artery and nerve of the same name. At the lower margin is another notch for the infra-orbital artery and nerve.

The globe is lodged in the orbit in a cushion of fat, and is held in place by connective tissue, the ocular muscles, and the eyelids. The periosteum of the orbit extends over its margin anteriorly to form the fascia tarso-orbitalis. Surrounding the posterior two-thirds of the eyeball, the connective tissue of the orbit becomes condensed into a capsule (Tenon's capsule above mentioned). (Fig. 2).

Posteriorly the orbit has three apertures: (1) optic foramen for the optic nerve and ophthalmic artery; (2) superior orbital fissure, opening into the middle fossa of the skull and transmitting nerves for the ocular muscles and the first branch of the trigeminal; (3) the inferior orbital fissure, connecting the orbit with the temporal fossa and serving for the passage of the second branch of the trigeminal nerve. Near the apex of the orbit is the ciliary ganglion, for the supply of the ciliary muscle and iris. Abnormal protrusion of the eye is exophthalmus. Absence of the bulb is anophthalmus.

The ocular muscles are divided into extrinsic and intrinsic muscles. The latter are the dilator and the sphincter pupillae. There are six extrinsic muscles, four recti and two obliques. The four recti muscles and the superior obliques have their origin around the margin of the optic foramen (Fig. 5), and diverge as they come forward to form the muscular funnel. The four recti muscles are attached by short tendons, to the sclera, 7 to 9 mm. from the cornea (Fig. 4).

The oblique muscles have a more complicated course. The superior oblique runs along the upper inner wall of the orbit to send its tendon through the trochlea and thence backward to its insertion in the upper half of the eyeball behind the equator. The inferior oblique arises near the lower inner margin of the orbit anteriorly and goes backward to its insertion behind the equator about in the horizontal meridian. (Fig. 4).

The muscles are innervated by three nerves. The oculo-motor nerve supplies the internal, superior and inferior recti, and the inferior oblique. Also the levator palpebrae superioris and the two interior muscles of the eye, (sphincter pupillae and ciliary muscle) are innervated by it. The external rectus has the abducens nerve; the superior oblique the trochlear. The nuclei for these various nerves lie upon the floor of the fourth ventricle.

By the action of the extrinsic muscles we use both eyes synchronously and have binocular vision. Disturbance of the muscular balance causes diplopia, because images are thrown on non-identical parts of each retina. Orthophoria is normal balance of the eye muscles. Strabismus, squint, is the condition in which only one eye fixes an object at a time. Paralysis of the ocular muscles is ophthalmoplegia.

The eyelids are in origin folds of skin

(Fig. 2), which have pushed their way over the bulb to protect it. The eyebrow, supercilium, limits the upper lid, while the lower lid passes without any sharp line of demarcation into the cheek. The palpebral fissure separates the two lids. Temporarily the lids join each other at a sharp angle—external canthus. The inner canthus is of horse-shoe shape, embracing a small fleshy growth—the caruncle. The surface of the lids next to the globe is lined by a mucous membrane—palpebral conjunctiva. When the eyelids are shut the entire conjunctiva forms a closed sac. Each lid is supported by a dense connective tissue plate—the tarsus. The upper lid is elevated by the levator palpebrae superioris, which has its origin at the apex of the orbit, and is inserted into the tarsus. The orbicularis palpebrarum closes the lids. This is a flat, cutaneous muscle surrounding the palpebral fissure in the form of a circle. Drooping of the upper lid is called ptosis.

The lacrimal gland, organ secreting the tears, is situated in a depression in the upper, outer wall of the orbit, near the margin. Smaller accessory glands are located along the inner margin of the upper tarsus. The tears contain but a small amount of solids, principally sodium chloride (hence salty tears). Psychic weeping occurs only in man. After removal of the gland the eye is kept moist by the secretion of the conjunctiva. Through the puncta the tears pass into the canaliculi and thence into the lacrimal sac. The latter is contracted below the nasal duct, emptying into the inferior meatus of the nose. Only when the secretion is much increased does any great quantity of tears discharge into the nose. Inflammation of the tear sac is called dacryocystitis. At the free margin of the lids there is a narrow strip—inter-marginal space—where the conjunctiva and the skin merge. The anterior margin is rounded and has swinging from it the cilia. The posterior margin is very sharp. Just in front of it is a row of orifices, mouths of the meibomian glands—sebaceous glands—embedded in the tarsal plates. They secrete oil to prevent the tears from running onto the cheeks. The modified sweat glands of Moll empty into the follicles of the lashes.



FIG. 6.

**Comparative Anatomy.**—In man the eye attains its highest state of development. The farther we descend the scale of animal life the simpler the eye and the more restricted its

functions. In the lower orders there are eyes which distinguish between light and darkness only. In the higher orders, as the vertebrata, the eyes perceive more or less perfect images.

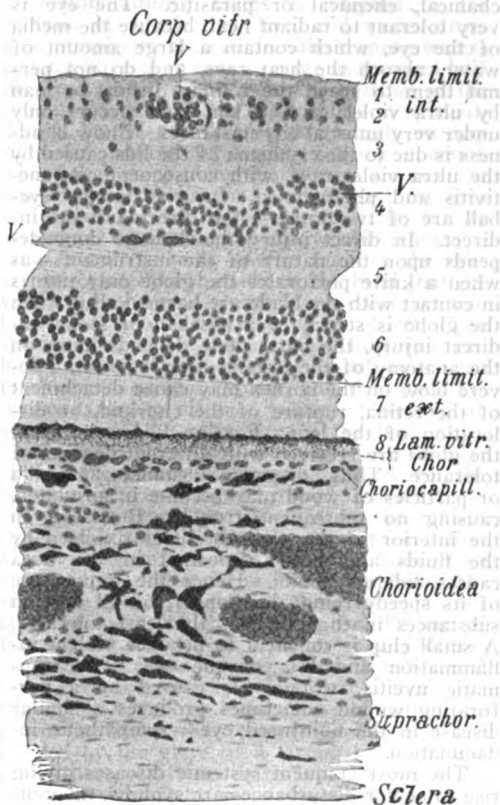

FIG. 7.

In many unicellular organizations—animals and plants, bacteria and protozoa—sensitiveness to light is a property of the body as a whole. In the more highly organized, multicellular animals certain cells have the function of responding to light, all others having lost it. The simplest form of visual organ consists of an epithelial cell connected with a nerve fibre. The cell has the power of transforming light into another form of energy that can be conducted along the nerve fibres to a central nerve organ. The eye of man is essentially reducible to an enormous number of sensory epithelial cells united to form the retina and optic nerve. These latter are the necessary parts of the eye, with the formation of which the development of the eye begins. All other parts of the eye develop later, and are designed for nutrition, protection or optical purposes. Thus the cornea and sclera protect the delicate retina, while the chorioid nourishes it. The cornea and lens refract the light and the iris, by means of its pupil, regulates the amount of light. Man and the higher animals are endowed with two eyes. Most insects and some crustaceans have two complete eyes with a number of single supernumerary ones. Some mollusks have as high as several hundred eyes which lie along their mantle.

**Diseases of the Eye.**—The morbid changes of the eye and its appendages vary according to the site of the disease. The causes of diseases are in a general way physical, mechanical, chemical or parasitic. The eye is very tolerant to radiant heat, because the media of the eye, which contain a large amount of water, absorb the heat rays, and do not permit them to reach the retina. Injury to man by ultra violet rays in sun light occurs only under very unusual circumstances. Snow blindness is due to the erythema of the lids caused by the ultra violet rays, with consequent conjunctivitis and photophobia. Injuries to the eyeball are of two kinds—the direct and the indirect. In direct injury the damage done depends upon the nature of the instrument—as when a knife perforates the globe only tissues in contact with the blade are harmed. But when the globe is struck by a baseball or stone, indirect injury, the harm done depends more on the anatomy of the organ. For instance, a severe blow on the cornea may cause detachment of the retina, rupture of the choroid, or dislocation of the lens. Foreign bodies entering the globe are received with different degrees of tolerance. Thus, organic substances, as cilia or particles of wood may become encapsulated, causing no subsequent trouble. But steel in the interior of the globe becomes oxidized by the fluids and being deposited in the uvea causes siderosis bulbi. Hence the importance of its speedy removal. Copper, of all foreign substances in the globe, is the least tolerated. A small chip is sufficient to produce violent inflammation and loss of the eye. The traumatic uveitis in one eye caused by a perforating wound sometimes produces a similar disease in the uninjured eye—sympathetic inflammation.

The most frequent systemic diseases giving rise to ocular disturbances are syphilis, tuberculosis, rheumatism, nephritis, diabetes, arteriosclerosis, diseases of metabolism and chronic intoxications. Between the ages of 5 and 15, in inherited syphilis, the cornea often becomes the seat of a cellular infiltration with new-formed blood vessels—the salmon patch—interstitial keratitis. Those afflicted with the disease usually exhibit a peculiar formation of the face and head. The bridge of the nose is sunken in. The frontal eminences are very prominent. The incisor teeth are abnormally shaped (Hutchinson's teeth). Frequently there is accompanying hardness of hearing. Bad teeth are not infrequently the cause of ocular symptoms and disease—as chronic iritis,—which clears up when the mouth receives proper attention. Other foci causing ocular disorders may be located in the tonsils, accessory nasal sinuses and intestinal tract. Acromegaly exhibits many ocular manifestations, as hypertrophy of the margins of the orbit and thickening of the skin of the lids. The accompanying disease of the pituitary body causes characteristic bitemporal hemianopsia. "Graves Disease" produces exophthalmus, sometimes so great that the lids can no longer cover the eyes. Acquired syphilis is responsible for at least 25 per cent of all cases of iritis. Atrophy of the optic nerve is found above all in tabes. It usually develops in the initial stage of tabes, at a time when the ataxic symptoms are slight or absent. Another

eye symptom which likewise makes its appearance early in this disease is the Argyll-Robertson pupil, in which the pupil reacts to accommodation and convergence, but not to light.

Many cases of impaired vision (amblyopia) and of blindness (amaurosis) are due to poisons introduced into the system which affect the optic nerve. Chief among these poisons are alcohol and tobacco, alone or combined. Other poisons causing amblyopia are lead, quinine and chloral. Nephritis (Bright's Disease) may cause oedema of the lids and albuminuric retinitis. Diabetes produces cataract and hemorrhages in the retina.

**Bibliography.**—Fuch's 'Text Book of Ophthalmology' (Philadelphia 1917); Week's 'Diseases of the Eye'; Salzmann, 'Anatomy and Histology of the Human Eye-Ball' (Chicago 1912); May, 'Manual of the Diseases of the Eye' (New York 1914).

BERNARD SAMUELS, M.D.,  
New York City.

**EYE STRAIN**, the result of using the eyes under adverse conditions. It is occasioned frequently by a lack of balance of the ocular muscles, but may be due also to the use of improper glasses or to the need of glasses. Its effects are serious; it is a great cause of waste of nerve force, causes headache, hysteria, chorea, convulsions, etc. It is remedied by proper glasses or by surgical operation.

**EYEBRIGHT**, a common name for the plants of the genus *Euphrasia* (q.v.).

**EYEPiece**, the lens or system of lenses in any optical instrument which lies next the eye and enables the image formed at the focus of the instrument to be observed. Its purpose is to form the image of a large field by pencils which, since they must enter the pupil of the eye, are necessarily of small divergence. Eyepieces are usually made of two lenses. The lens nearer the eye is called the eye-lens, the other the field-lens. In the Ramsden eyepiece, eye-lens and field lens are equal and plano-convex, and have the convex sides turned toward one another. In the Huygens eyepiece the field-lens has a larger focal length than the eyepiece, and the curved surface of both lenses are turned toward the object. These eyepieces are used both for microscopes and for telescopes and give inverted images. For erect images, as in opera glasses, a convergent eyepiece is used, or where a larger field of view is desired the inverting eyepiece of an ordinary telescope is used to magnify an image which is itself inverted by a convergent system of lenses between the objective and the eyepiece proper, or by a system of two right-angled reflecting prisms, as in the Zeiss binocular.

**EYERMAN**, John, American geologist: b. Easton, Pa., 15 Jan. 1867. He studied at Lafayette College, Harvard and Princeton, and was instructor in blow-piping at Lafayette 1888-93 and lecturer on determinative mineralogy. He has been an associate editor of the *American Geologist* since 1890, and is a member of many English and American scientific societies. He has published 'Notes on Geology and Mineralogy' (1889); 'Mineralogy of Pennsylvania' (1891); 'Course in Determinative Mineralogy' (1892); 'Bibliography of North American Vertebrate Palæontology' (1889-93);



'The Genus *Temnoeyon*' (1895); 'A Study of Genealogy' (1898); 'General Index of the Wills of Northampton County, 1752-1802' (1898); 'The Old Grave Yards of Northampton' (1889-1901); 'Some Letters and Documents' (2 vols., 1900); 'Genealogical Studies' (1902).

**EYESIGHT IN THE LOWER ANIMALS** presents some curious differences from that in man and his nearer allies. The rudimentary eyes of the lower invertebrates can hardly be of more service than to convey an impression of the difference between day and night; many such come out of the ground, or rise to the surface of the sea, at night to sink again into darkness when the sun rises. In echinoderms, the starfishes for example, eyes are found that contain "many clear oval bodies imbedded in pigment, which," Huxley says, "appear to represent the crystalline cones of a compound eye." (See *EYE*). Among mollusks the organs of vision range from none at all in certain deep-sea species through all degrees of complexity to the highly developed eyes of the squid. Bivalves that creep about near shore, daily exposed between tides and subject to capture, have many eye-spots on the edge of the mantle, which are so sensitive that the shadow of a boat or of a man will cause instant closure of the shells. This is most noticeable in the scallops (*Pecten*), where a row of eyes glisten like jewels when the shell is open; and in the ark-shells (*Arca*), where a great number of eyelets are gathered in round groups forming compound eyes. In most univalve mollusks there are two eyes on the head at the base of the "feelers"; but in the land-snails the eyes are usually at their tips. Experiments show that snails are very short-sighted and see better in a subdued than in a bright light; but some seem to perceive subjects well several inches away. The eye of an octopus or a squid is very large and perfect, and as useful as that of a predatory fish which the squid resembles in habits. Among the trilobites and crustacea, also, the agile, prey-hunting species are provided with efficient compound eyes, usually set at the end of stalks that may be turned in any direction. These eyes are always compound, like those of insects—that is, consist of a honey-comb-like aggregation of somewhat modified simple eyes (facets) backed by one retina. Through each facet, it is believed, falls an exceedingly fine pencil of light, revealing a very small part of the field of vision. These combined fragments are supposed to form a sort of mosaic picture on the retina and in the insect's brain; and its field of view must depend on the number of facets and the approximation to the globular form of the whole external eye. The nature and value of insect-vision has been much discussed. Carpenter ('*Insects and their Structure and Life*' 1899), reviewing the controversy, concludes that the compound eye is especially adapted for perceiving sensations of light and motion rather than of form. There is reason to believe that such eyes do not perceive objects at a greater distance than six feet, while there is no doubt that they are able to appreciate color-sensations; in fact, the theory of the cross-fertilization of flowers by insects largely depends on this assumed ability. Dragon-flies, which have very large protruding eyes, of many

thousand facets, often approach close to a person and hover there, evidently studying the details of the moving object (one's self) that has attracted their attention.

**Vision among fishes** is adapted to the medium in which they live, and varies from total atrophy of the eyes in subterranean waters and sea-abysses to eyes so large as to equal half the head. The relative size and position of the eyes in the head varies with habits in a bewildering degree, as fishes depend largely on eyesight for finding food and escaping enemies. Those that creep along the bottom, or dwell at intermediate depths, for instance, have the eyes on top of the head, looking upward; but to catalogue these adaptations would require a long essay. In most of the families the eyes are so situated in the side of the head that the vision is monocular—that is, only one eye can be used at a time for viewing an object. The species that chase fleeing prey, however, can look forward with both eyes. Such eyes need to change the focus rapidly, and this quick accommodation to distance is not effected by an alteration of the convexity of the lens, as in birds and mammals, but by a muscular change in its position with regard to the retina. The structure of the fish-eye is substantially the same as that of the human eye, with the important exception that in all deep-sea fishes only the rods (see *EYE*) exist in the retina, the cones being absent; the conclusion is that these fishes do not perceive color, which seems to be the special function of the cones. Furthermore, a difference in the retina of the deep-sea fishes and other creatures indicates that these animals are "day blind," that is, have eyes adapted to the gloom in which they constantly live and are blinded by the glare of a strong light. It appears, however, that there is no regular decrease in size of the eye, from a small or normal form at the surface to the immense and well-developed eye that characterizes many of the fishes dwelling in the oceanic abysses. The pelagic fishes with largest, most efficient eyes, are those living at a depth of from one to 300 fathoms and possessing light-organs, while below that stratum both light-organs and eyes decrease in size until the deep floor of mid-ocean is reached, when again big-eyed species occur. The only present explanation of the latter fact is that those abysses are lighted by the glow of innumerable phosphorescent invertebrates, by whose light the fish seek their food.

Little need be said of the vision of amphibians and reptiles, which is probably rather dull and restricted. These animals, like many fishes, depend more on the sense of smell than on sight to guide their actions, and have, in addition, good hearing.

**Vision of Birds.**—The power of vision attains its highest development among birds; and nowhere but in human faces is the eye so expressively beautiful or so exquisitely adapted to its service as an optical instrument. Birds possess the keenest and most farsighted vision, and also extraordinary power of swiftly altering the focus of the eye to changing distances, accompanied by astounding acuteness in mental calculation. A swallow or nighthawk sweeping and dodging in the air is catching insects almost invisible to our eyes and excessively agile; a

hawk chasing a swift-winged and quick-turning sparrow or a leaping grasshopper must have eyes that can follow exactly every movement. More wonderful is the work of an eagle or vulture, which while soaring so high in the sky that it appears to us a mere speck sees and defines an object on the ground that we could hardly notice or recognize at a hundred yards, and darts down upon it with the speed of a bullet. Imagine the farsighted keenness of this act and then the perfection of the apparatus by which the focus of the eye is changed in accord with the speed of the bird's descent, keeping the object always in clear view and stopping at precisely the right instant to escape collision. A hummingbird will dash past one's eyes like a gleam of light and halt at rest on a twig without fail. A woodcock or partridge will rush at high speed through a tangled wood and never touch a twig. These feats are evidence of the perfection of birds' eyes, especially in the faculty of accommodation to quickly varying distances.

Eyesight among mammals is relatively less important than among birds, or even to mankind, for their alert hearing and keen sense of smell give them much information. Vision among them varies with their manner of life, and is restricted to their needs in each case. The most farsighted and useful vision, probably, is that of the large grazers on the plains — deer, antelopes, giraffes, horses, etc., although they use but one eye at a time. The beasts of the chase, like owls among birds, have eyes in front, so that they observe with both at once, and of these perhaps the wolves, foxes and wild hunting dogs are best endowed. Here as elsewhere structure of the eye and quality of vision are in adaptation to the habitual needs of each kind of animal, and are always correlated with the power of locomotion.

ERNEST INGERSOLL.

**EYETEETH, CANINE or CUSPIDATE TEETH**, two teeth in the upper jaw, the fangs of which project in the direction of the eye. See **TEETH**.

**EYLAU**, i'low, or **PRUSSIAN EYLAU**, Germany, town on the Pasmur River and the lake of Arschen, 22 miles south of Königsberg. It was the scene of a battle, fought 7-8 Feb. 1807, between the French under Napoleon (q.v.) on the one side and the allied Russians and Prussians on the other side. (See **NEY**). The French force numbered about 70,000, of whom fully 18,000 were killed. The allied forces were about the same in numbers, with a loss of more than 18,000. Pop. about 3,000.

**EYLAYET**. See **VILAYET**.

**EYMERICUS**, Nicolas, Spanish theologian: b. Gerona, Catalonia, 1320; d. 1399. In 1334 he entered the Order of Preachers, later attaining the rank of Grand Inquitor. He also was appointed chaplain to Pope Gregory XI and judge of heretics in 1356. He lived many years at Avignon during the reigns of Clement VI and Benedict XIII. He was the author of the severe 'Directorium Inquisitorum,' which was the standard code of procedure in the Inquisition for nearly one hundred years.

**EYNARD**, ā'nār, **Jean Gabriel**, French banker: b. Lyons, 1775; d. 1863. For his partic-

ipation in the outbreak at Lyons against the Convention, Eynard became *persona non grata* to the authorities and sought asylum in Switzerland and later in Genoa, where he amassed a fortune. In 1810 he removed to Geneva, and was Ambassador of the Geneva Republic at the Congress of Vienna in 1815. In the following year he helped to organize the administration of Tuscany, which he represented at the Congress of Aix-la-Chapelle in 1818. He advocated the independence of Greece and for his services to this cause was made a Greek citizen. His personal contribution to the Greek revolutionaries amounted to Fcs. 700,000 (\$140,000). His recommendation of Otho of Bavaria for the throne of Greece was adopted. He bequeathed his fortune of about \$12,000,000 to various charitable enterprises. He wrote 'Lettres et documents officiels relatifs aux divers événements de Grèce' (1831) and 'Vie de la baronne Krüdener' (1849). Consult Rothpletz, 'Der Genfer Jean Gabriel Eynard als Philhellene' (Zürich 1900).

**EYRE**, ār, **Edward**, American financier: b. Dublin, Ireland, 25 March 1851. He was educated at the Jesuit school, Belvidere Place, Dr. Quinn's Preparatory School, and at Trinity College. He entered the employ of Grace Brothers and Company, becoming junior partner in 1876 and full partner four years later. He was one of the original founders of Grace House, Chile, in 1882, and became successively manager, vice-president and president of the W. R. Grace Company, New York, in 1903-06. Since 1906 he is a member of the board of managers of the London branch of W. R. Grace Company. Mr. Eyre took prominent part in bringing about a settlement of Peru's foreign debt after the war with Chile, and for some time was manager of the railroad systems handed over by Peru to its creditors. In 1892 he negotiated with Chile for the settlement of the claims against her made by the holders of the Peruvian bonds, due to the seizure by Chile of the guano deposits and other properties which formed part of the guarantee of the bonds from Peru. In 1898 Mr. Eyre, on behalf of an American syndicate, obtained from Nicaragua a concession for the construction of an inter-oceanic canal through that country, the project being subsequently held up by the government of the United States; the text of this concession was used later by the United States government in its treaty with Colombia and appears almost verbatim in the treaty actually concluded between the United States and the Republic of Panama. Mr. Eyre was a member of the board of directors of 'The Catholic Encyclopædia' and the council of the Westminster Catholic Federation and is an ex-president of the Marquette League. He published a criticism of Viscount Bryce's 'South America: Observations and Impressions.'

**EYRE**, **Edward John**, English explorer and colonial governor: b. Yorkshire, 5 Aug. 1815; d. Tavistock, Devonshire, 30 Nov. 1901. He went to Australia in 1833; in 1839 discovered Lake Torrens, and in 1840 explored its eastern shores and the adjacent Flinders Range. He then commenced his perilous journey along the shores of the Great Australian Bight, and reached King George's Sound, in western Australia, a distance of 1,200 miles, accompanied by

a single native boy, having left Adelaide more than a year before. In 1845 he published 'Expeditions into Central Australia.' After filling several governorships he was appointed governor of Jamaica in 1862. In 1865 he was confronted with a negro rebellion which he crushed with some severity, and was recalled. On his return to England John Stuart Mill and others took measures to have him indicted for murder, but failed. In regard to this question Carlyle was one of his most strenuous defenders.

**EYRE, Sir James**, English jurist: b. Wells, Somersetshire, 1734; d. 1 July 1799. In 1747 he was appointed scholar of Winchester and two years later became a student of St. John's College, Oxford. In 1753 he went to London, took up the study of law, and in 1755 was called to the bar. He became counsel to the Corporation of London and recorder in 1763. In 1772 he was made Baron of the Exchequer and knighted, becoming chief Baron 15 years later. In 1793 he was made chief justice of the Court of Common Pleas. From June 1792 to Jan. 1793 he was chief commissioner of the Great Seal. Consult Foss, 'Lives of the Judges of England' (1848-64).

**EYRE, Jane**. See JANE EYRE.

**EYRE, Jehu**, colonel in the Continental army: b. 10 Jan. 1738; d. July 1781. Eyre is the name of a family that for seven centuries has been famous in the English history, the founder having come over the sea with William the Conqueror. The legendary account states that when, at the battle of Senlac, or Hastings, the Norman leader, early in the conflict, was knocked by a missile off his horse, he lay senseless on the ground, until a soldier stepped forward and loosened his visor, which gave him air. Thereupon William, reviving, asked for his benefactor and knighted him on the spot, giving him the name of "eyre"—one of the variants of a word that is older than English spelling. In the feudal division of land, this Norman Baron le Eyr—whose crest was a leg in armor, couped and spurred, he having lost a leg in the battle—was given a fief in Nottingham, the manor house being at Rampton. The family is now extinct in the peerage. The first American ancestor, George Eyre, coming from Worksop, settled at Burlington, N. J., and married in a family of Friends. He had three sons who, in the Revolution, became "Free" or "Hickory" Quakers and were prominent in the service of the Continental Congress. Coming to Philadelphia to learn shipbuilding, two of the sons married sisters, the daughters of their master.

On the fall of Fort du Quesne and its remaining after Pitt, Jehu Eyre traveled with a party of his mechanics to build boats for the transportation of the King's forces down the Ohio. While there, he learned about cannon and artillery, visiting also Braddock's Field—then piled with the bones of the slain. After the Lexington news, he organized in Philadelphia a military company, which guarded Independence Hall. Besides providing boats for the crossing of the Delaware, he took part in the battle of Trenton and Princeton; in which latter, his younger brother, Colonel Benjamin George, was aide to Washington. In 1777, Jehu was made colonel of an artillery regiment which served at Brandywine, wintered at Valley Forge,

and garrisoned the forts on the Delaware, while Proctor, with his artillery, was away on Sullivan's Expedition (q.v.). He left five children. Consult Keyser, 'Pennsylvania Magazine of History and Biography' (1879).

WILLIAM ELLIOT GRIFFIS.

**EYRE, Wilson**, American architect: b. Florence, Italy, 30 Oct. 1858. He was educated in Italy until 1869, at Newport, R. I., from 1869 to 1872, at Lenoxville, Canada, from 1872 to 1874, and at the Massachusetts Institute of Technology, where he was graduated in 1876. From 1876 to 1881 he was with James P. Sims and from 1881 to 1912 was in independent practice. In the latter year he became senior partner with John G. McIlvaine. He has built many buildings in Philadelphia and New York, also several buildings for Newcomb Memorial College, New Orleans, the Detroit Club, Detroit, etc. He is a member of the American Institute of Architects, the National Academy, etc.

**EYRE LAKE**, a salt lake of South Australia, lying due north of Spencer Gulf, 35 feet below sea-level, in the driest part of the continent, where the rainfall is only five inches per annum. Area 3,706 square miles. During Mesozoic times, a large gulf extended from the Gulf of Carpentaria to Lake Eyre. Its southern arm usually contains salt water; the remainder is a vast salty plain formed from alluvium carried down by the large rivers of Central Australia which now enter it only at flood time.

**EYRIA** (Fria) **PENINSULA**, on the south coast of South Australia, triangular in shape, its base being formed by the Gawler Range, while its sides are washed on the southeast by Spencer Gulf, and on the southwest by the Great Australian Bight. It is a rich wheat-growing country.

**EYTELWEIN**, Ftel-vin, **Johann Albert**, German engineer: b. Frankfort-on-the-Main, 1764; d. 1848. In 1799 he became director of the Berlin Architectural School; afterward he was placed in charge of the hydraulic operations for improving the navigation of the Niemen, Oder, Warthe and Weichsel. He also had charge of harbor improvements at Memel, Pillau and Swinemünde. He established a system of weights and measures for the kingdom of Prussia. His works include 'Praktische Anweisung zur Bauart der Fashinenwerke an Flüssen und Strömen' (2d ed., 1818); 'Vergleichung in den preussischen Staaten eingeführten Masse und Gewichte' (2d ed., 1910); 'Handbuch der Statistik fester Körper' (2d ed., 1832); 'Handbuch der Hydrostatik' (1826); 'Auflösung der höhern numerischen Gleichungen' (1837).

**EYTH, Eduard**, Ed'oo-ärd It, German poet: b. Heilbronn, Würtemberg, 2 July 1809; d. New Ulm, 28 April 1884. He was author of a volume of 'Poems' (1843); 'Pictures in Frames' (1856); and a version of the 'Odyssey.'

**EYTH, Max**, German agriculturist: b. Kirchheim-unter-Teck. 1836; d. 1906. He came to England in 1861, and entered Fowler's agricultural implement works at Leeds as engineer that same year. In 1863-66 he served in Egypt as chief engineer to Halim Pasha, and introduced the steam plow into Egypt. He published 'Das Agrikuturwesen in Ägypten'

(1867); 'Steam Cable Towing' (1868); 'Das Wasser im alten und neuen Ägypten' (1891); 'Wanderbuch eines Ingenieurs: In Briefen' (1871-84); 'Lebendige Kräfte' (1905).

**EYTINGE**, ət'ing, **Rose**, American actress: b. Philadelphia, 21 Nov. 1838; d. 1911. She made her début as an amateur in Brooklyn, N. Y., 1852, and the following year played through the West in a stock company. From 1862 to 1869 she played in various theatres in New York and then went abroad with her second husband, George H. Butler, consul-general to Egypt. On her return thence in 1871 she took the rôle of Cleopatra at the Broadway Theatre, to the Antony of Frederick Warde. Among her parts were Nancy Sykes in 'Oliver Twist'; Gervaise in 'Drink'; Ophelia to the Hamlet of the E. L. Davenport, and Desdemona with James W. Wallack as Othello and Davenport as Iago. She created many parts, including Rose Michel, Amande Chandoce in 'Led Astray,' and Felicia in the play of that name, but was especially successful in her playing of Shakespearean rôles, notably Cleopatra, Lady Macbeth and Hermione (in the 'Winter's Tale'). She wrote 'It Happened This Way,' a novel; 'Golden Chains,' a play; and has dramatized Browning's 'Colombe's Birthday,' and Dickens' 'Dombey and Son'; 'David Copperfield'; 'Oliver Twist'; 'Tale of Two Cities.' She also published 'Recollections,' and 'Memories' (1905). Consult Clapp and Edgett, 'Players of the Present' (New York 1899); and Winter, 'The Wallet of Time' (2 vols, ib., 1913).

**EYUK**, ä-yook, Asia Minor, a village situated about 75 miles southwest of Amasia, and noted for its remarkable groups of ruins. The ruins are the remains of a colossal palace of the Hittites, whose capital Hatti (modern Boghaz Köi) is only a short distance from Eyuk. Consult Garstang, 'The Land of the Hittites' (New York 1910); Olmstead, C., and Wrench, 'Hittite Inscriptions' (1911); Winckler, 'Nach Boghaz Köi' (1914).

**EYZAGUIRRE**, ä's-thä-gē'rä, **Agustin**, Chilean statesman: b. 1766; d. 1837. He became a prominent figure in 1810 in the movement for independence and three years later was a member of the first Junta. In October 1814 he was captured by the Spaniards at Rancagua and spent the three years following in captivity on the island of Juan Fernández. In 1823 he was chosen president of the provisional Junta and soon after vice-president of the Republic. In 1826 he became acting President, on the resignation of Freire, but was deposed in January 1827 by malcontents in the army.

**EZEKIEL**, one of the greater Hebrew prophets. To him is attributed one of the larger prophetic books of the Old Testament, the visions and utterances which it contains being expressly attributed, in the work itself, to Ezekiel. He was the son of Buzi, a priest, and was carried captive, in the time of Jehoiachin, 597 B.C., about 11 years before the destruction of Jerusalem under Zedekiah. His prophecies are mostly in chronological order, those excepted which are launched against foreign nations. The central idea in the book is that Jerusalem because of its corruptions is doomed, and that the future of the chosen

people is with the exiles of Babylon. Ezekiel marks the transition from the prophetic to the priestly period. There is no direct quotation from Ezekiel in the New Testament, but there are a few allusions to his utterances, especially in the Book of the Revelation, which, in the concluding portion, distinctly looks back to the temple arrangements prophesied in the last chapter of Ezekiel. The substantial genuineness and authenticity of the prophecies of Ezekiel have not been seriously impugned either in the Jewish or Christian Church, and nearly universal suffrage has been given in favor of their canonicity.

**EZEKIEL**, Book of. The third of the "major," or longer, prophetic books of the Old Testament, derives its title from its author, the priest-prophet who bore the name "God strengtheneth." The Hebrew form is represented more closely in the English of I Chronicles xxiv, 16 by the name Jehzekel, a priest ascribed to David's time. No one else in the Old Testament bears this name, although the familiar Hezekiah, "Yah strengtheneth" or "hath strengthened" is of similar import. The author, as one of priestly rank, was among the eight or ten thousand men of standing who with their families were taken to Babylonia in the first exile, 597 B.C. The company of which he was a member formed a community, presided over by its own elders, on the banks of the river Chebar. American excavations in central Babylonia have identified this with the canal Kabaru, "the Grand Canal," which ran near the ancient, famous seat of Babylonian worship, the city of Nippur. Here Ezekiel lived in his own house, where the elders and people resorted to him to inquire of Jehovah (viii, 1; xiv 1; xx, 1; xxxiii, 30-32). Here, too, in the ninth year of the captivity, his wife died, and he restrained himself from the usual signs of mourning that he might impress upon the people a sense of the stupefying grief that was soon to fall upon them through the destruction of Jerusalem. Ezekiel's familiarity with the worship of the temple leads to the inference that he was already an active priest before the captivity. It was not until the fifth year of the exile (592 B.C.) that he became conscious of his prophetic call through an impressive and repeated vision which assured him that he had the work of a prophet to perform as a spokesman of God (i-iii). For at least 22 years, until 570 B.C. (xxix, 17), Ezekiel continued to interpret the Divine will and purpose to his fellow exiles, using every ingenious device of symbolic action and figurative speech to arouse their curiosity and interest and make his message penetrate the "hard forehead and stiff heart." The contents of the book of Ezekiel are arranged, for the most part, in chronological order and fall also into clearly marked topical divisions. Chapters 1-24 contain oracles from the beginning of the prophetic ministry in 592 to the investment of Jerusalem by the Babylonian armies in January 587 B.C.; these deal with the approaching fall of the city. Chapters 25-32 pronounce judgment upon Israel's ancient neighbors, Ammon, Moab, Edom, Philistia, Tyre and Egypt; they prepare the way for Israel's complete restoration to her land, freed from the old, troublesome neighbors. The

oracles of this second section of the book are dated within the period of one or two years from January 586 to March 585 or 584 B.C., except for a slight addition made by the prophet in the year 570. Chapters 33-48 contain the direct prophecies of restoration with which Ezekiel sought to encourage and guide his fellow exiles after the destruction of Jerusalem in the summer of 586 B.C. The second division of these prophecies of restoration (40-48) is dated as late as 572; this contains Ezekiel's detailed plans for the restored temple and worship, and the systematic redistribution of Palestine among the 12 tribes, the Prince, the priests and the Levites. Ezekiel's early ministry was contemporary with the later years of Jeremiah. Though the two men were as different as possible in their mode of thought and expression and in some of their conceptions, they were in full agreement in their central emphasis, at this time, upon the certainty of Jerusalem's destruction and of a restoration after long years. Ezekiel, too, even more clearly than Jeremiah, enunciated the doctrine of the individual's relation to God, in contrast to the earlier prophetic message of the nation's relationship, and reiterated Jeremiah's teaching of a new spirit within guiding the life in the Divinely appointed ways. Ezekiel renews the charges of bribery, greed, oppression of the defenceless, social corruption and blood guiltiness that the 8th century prophets had made against the people; but he gives equal or greater prominence to the corrupt worship that had come flooding into Jerusalem under Manasseh and again under Jehoakim. His references to economic crimes, which the earlier prophets had painted so vividly, seem rather general and perfunctory, while his pictures of the idolatrous practices in the temple are most concrete and vivid (viii, 5-8). To him it is clear that Jehovah must vindicate upon his people his outraged honor and holiness. As in Deuteronomy, the priestly demand for purity of worship and the prophetic demand for moral character are united; but in Ezekiel the ritual conception of holiness is much more prominent than the moral. This writer is in fact more fully the heir of priestly ideals and the precursor of the age of ritual dominance than the successor of the great ethical and spiritual prophets of the centuries immediately preceding. In the development of Levitical organization Ezekiel's ideals stand between the simpler arrangements of Josiah's time and the completed hierarchy of post-exilic Judaism. His influence upon later generations in furthering the eclipse of the prophetic religion by sacerdotalism was important. Attributable to him is the conception of a sacred nation isolated from all others, which played so large a part in rebuilding and preserving the Jewish community after the exile and which led also to the exclusive, ceremonial ideas that culminated in Pharisaic Judaism. This prophet's influence was equally determinative in shaping the Messianic hopes of later centuries. In this stream of influence issuing from his teachings we may distinguish elements which ultimately came to flow in very different channels. On the one hand, he gave the beautiful picture of the good shepherd (34). In this he described

the manner in which the former rulers and strong ones had taken advantage of their position to secure the best water and pasture and wantonly to destroy and foul that which they could not themselves consume. In contrast, he promised the era of justice and safety when God himself would defend the flock and his servant David should feed and shepherd them. Again Ezekiel promised from God a new heart of flesh instead of their old stony heart; Jehovah's Spirit within them causing them to walk in all his ways (xxxvi, 22-27). On the other hand, he taught that God must re-establish and glorify his people in order to make his own name great among the nations which now despised him as a discredited deity unable to protect his own people from their enemies. He feels the mere restoration of Israel to the land inadequate in itself to vindicate the Divine power, and foresees a time when Israel, gathered out of all lands, shall dwell securely; then hordes from the north shall sweep down over the land, as the Scythians had come a generation before. Suddenly God will smite down, upon the mountains of Israel, this awe-inspiring multitude of King Gog, there to lie as prey of the ravenous birds and beasts. Then Jehovah's holy name will be made known in the midst of Israel and the nations will know that he is the Holy One in Israel (38-39). Here holiness is evidently understood in its primary Hebrew conception of separateness or unapproachableness without the moral connotation that the great prophets had given it. This particular vision of Ezekiel seems to have been the original of that picture of the future which appeared in varied, fantastic forms in the Jewish apocalyptic writings of the two centuries before Christ and the opening years of the Christian era.

In this book the descriptions of symbolic acts and visions, characteristic of the Hebrew prophets, are carried to an extreme unknown in the earlier documents. Doubtless the elaborate, composite, human-animal figures conspicuous in the Babylonian sculptures influenced the form of Ezekiel's visions. The beings seen in the opening vision, each with the face of a man, a lion, an ox and an eagle, each with four wings, with human hands beneath the wings and feet like those of a calf, seem fairly to outdo the fantastic imaginings of the sculptors of Babylonia. An Amos or an Hosea thought in the pictures of the varied hills and skies and mountain torrents of Palestine; Ezekiel, on the endless plain by the sluggish canal, thought in pictures suggested by the most impressive work of the artists who had decorated the great temples for the ancient worship of this centre of mighty human power. With the audacity of faith belonging to the true interpreters of the unseen God, the exile prophet appropriated the symbols of the conquerors' religion to enforce his own lessons as to the power and purposes of the God of subject Israel. At times, the imagery of the prophet is more simple and becomes effective or even beautiful. An example in point is the picture of the Divine shepherd and the sheep, but generally the figures, even at their best, seem labored. A few poems are introduced here and there among the prose oracles. In the dirge sung over Tyre (xxvii, 3b-9a, 25b-36)

we have one of the most elaborate and appropriate of the many poetic descriptions of the ship of state. In the lament for Egypt (xxxii, 19-32), both the conception and the form of the poem, with its varied haunting, baffling refrain are notable. In general, however, Ezekiel lacks the poetic power and the rhetorical passion of the greatest of Israel's prophets. The book shows the marks of deliberate literary composition far more even than that of Jeremiah, of whose repeated dictation to Baruch of sermons long before delivered, we are told. The books of Hosea and Isaiah suggest in their arrangement scattered memorials gathered by loyal followers. In the case of Ezekiel it seems evident that he committed his own teachings to writing with deliberation and that he finally composed the entire book in essentially its present form. The internal evidence of the book speaks of unity of plan and purpose and of date of composition. Although the text has suffered more than usual corruption through copyists' errors, the book as a whole is singularly free from later additions or expansions.

**Bibliography.**—Bennett, W. H., 'The Religion of the Post-Exilic Prophets' (Edinburgh 1907); Davidson, A. B., 'The Book of Ezekiel' (in Cambridge Bible, Cambridge 1892); Fowler, H. T., 'A History of the Literature of Ancient Israel' (New York 1912); Kent, C. F., 'Sermons, Epistles, and Apocalypses of the Prophets' (New York 1910); Redpath, H. A., 'The Book of the Prophet Ezekiel' (in 'Westminster Commentaries,' London 1907); Skinner, J., 'The Book of Ezekiel' (in 'Expositor's Bible,' New York 1901); Toy, C. H., 'The Book of Ezekiel' (in 'Sacred Books of the Old and New Testament,' New York 1899). Consult also Hastings, 'Encyclopedia Biblica' and the Old Testament Introductions by Creelman, Cornill, Driver, Gray, McFadyen, Moore.

HENRY THATCHER FOWLER,

*Professor of Biblical Literature and History,  
Brown University.*

**EZEKIEL, Moses Jacob,** American sculptor: b. Richmond, Va., 28 Oct. 1844. He was graduated at the Virginia Military Institute 1866, having served in the Confederate army during the last year of his course. He studied art in Richmond and Cincinnati 1866-70, and Berlin, Germany, 1870-74, where he was the first foreigner to win the Michael Beer prize (1873). While there he studied under Prof. Albert Wolf, and was admitted to the Berlin Society of Artists on the merits of his colossal bust of Washington, now in Cincinnati. Later he went to Rome, Italy, where he has chiefly resided save for frequent visits to America. He has exhibited in the chief American and European expositions. Large and small, including statues, portrait-busts, ideal groups, and reliefs. His works number several hundred of which the best known are 'Cain, or the Offering Rejected,' an early ideal bust that showed considerable dramatic talent; 'Apollo and Mercury,' Berlin (1870); 'Religious Liberty,' Fairmount Park, Philadelphia (1874-76); bas-relief portraits of Farragut (1872), and Robert E. Lee (1873); 12 marble statues of artists for the Corcoran Art Museum, Washington (1880-82); marble busts of Beethoven (1884), Longfellow, and of Cardinal Hohenlohe (1888);

bronze statue of Columbus in the Columbian Memorial building, Chicago, Ill.; statue of Mrs. Andrew D. White for Cornell University; bust of Lord Sherbrooke for Westminster Abbey; the fountain of Neptune for the town of Neptune, Italy; Confederate Soldiers' Monument in the National Cemetery, Arlington, Va., etc. In June 1903 the sculptor presented a bronze monument, 'Virginia Mourning Her Dead,' to the Virginia Military Institute.

**EZION-GEBER,** *ē'zī-ōn gē'bēr*, a stopping-point of the Israelites on their journey from Egypt (Deut. ii, 8). It is probably identical with the modern Ain-el-Ghudyan. It is mentioned also as the station of Solomon's fleet (I Kings, ix, 26; II Chron. viii, 17). According to Josephus it was known as Berenice in his day. Consult Musil, 'Arabia Petraea: Edom' (Vienna 1908).

**EZRA,** the Babylonian Hebrew priest surnamed "THE SCRIBE," after whom, with his contemporary Nehemiah, the 'Books of Ezra and Nehemiah' of the Hebrew canon are named. By permission of King Artaxerxes I of Babylon, as leader of 1,754 of his countrymen he returned to Jerusalem 458 B.C. On the basis of a firman granted by the King, and by the appointment of the King's cup-bearer Nehemiah as governor of Judea 445 B.C., he was instrumental in purifying and re-establishing, under sanction of the law, the Jewish religion in Jerusalem, where it had become deeply corrupted. The drastic steps associated with the reforms of Ezra and Nehemiah were not acceptable everywhere and led to endless discussion, especially was this the case when a great number of the Jews were compelled to divorce the foreign wives they had married. The most famous of the early scribes, Ezra is referred to as "the scribe of the commandments of the Lord and of his statutes to Israel" (Ezra vii, 2) and as "a ready scribe in the law of Moses which the Lord, the God of Israel had given." He was the first of the Sopherim or scribes who handed on the charge to the "Men of the Great Synagogue," a body or succession of teachers which he founded and now represented by the rabbis. To Ezra is credited the introduction of Assyrian script, or the adoption of Aramaic handwriting in Judea in the 5th century B.C. In 444 B.C. Nehemiah describes Ezra as a scribe reading the 'Book of the Law' to the congregation of the children of Israel gathered on the plateau near the Water Gate, and the Levite priests reciting the 'Targums' or Aramaic paraphrases to enable the people to understand the laws. The reading occupied two days and was productive of impressive results. The important services rendered by Ezra to his countrymen on that occasion, and also in arranging and practically settling the canon of Scripture are especially acknowledged by the Hebrews, and he is even regarded by many as the second founder of the nation. Malachi, signifying "My Messenger," the name assigned to the last book of the Old Testament, is identified by some authorities with Ezra. Some writers assert that Ezra returned to Babylon and died there at the age of 120 years. Josephus states that he died in Jerusalem and was buried there with great pomp. On the Shatt el-Arab near Korna the tomb of Ezra is venerated as a shrine. Consult

Herford, 'Pharisaism' (New York 1912); Torrey, 'Ezra Studies' (Chicago 1910).

**EZRA, Book of.** For the discussion of the original union of Ezra with Nehemiah and Chronicles and for the date of the complete work, see **CHRONICLES**.

The book of Ezra covers the history from 537 B.C. to 458, although some would substitute another date for the latter one. Most of this period is described very briefly, with extended sections of which nothing is said; it is the narrative of the events of the year 458 that is most extended, chapters vii-x.

Chapters i-vi are claimed to rest upon certain official documents which were partly in Hebrew and much more largely in Aramaic. Whether this claim is true is a matter on which there is difference of opinion; it is probable that it is in large measure true, but perhaps not altogether. The remainder of the book, chapters vii-x, is evidently based upon memoirs of Ezra. These memoirs as they now appear are partly in the first person, having been quoted by the writer verbatim or with slight changes, and partly in the third person, having been considerably rewritten. Ezra vii, 27-ix, 15 are of the former kind; Ezra vii, 1-26; 10, of the latter kind.

The question of the historic city of Ezra and Nehemiah is one of much difficulty. The compiler seems to have had access to more accurate records for this period than for the earlier time covered in the books of Chronicles. Nevertheless, there are many unhistorical details in these books, and many that are doubtful. Ezra iv, 7-24a is out of its chronological order. The question of the proper order is one on which there is much difference of opinion.

The register of returning exiles in Ezra ii is substantially identical with that in Nehemiah vii, 6-73a, where it is put chronologically at a later point. The connection in Nehemiah is probably more nearly the original one, and the connection in Ezra is unhistorical.

The so-called Septuagint translation of Ezra and Nehemiah, which some have considered to be actually the version of Theodotion, is called 2 Esdras, Esdras being the equivalent of Ezra. 1 Esdras is a so-called apocryphal book, now known only in Greek. It contains the book of Ezra, practically entire, with small portions of 2 Chronicles and of Nehemiah. It is now generally accepted that the book of 1 Esdras is a variant recension of these portions, translated from a Hebrew and Aramaic original. There is considerable chronological rearrangement of the material, and the order of 1 Esdras is now considered to be on the whole superior. 1 Esdras iii, 1-v, 6 is the only portion which has no parallel in these other books.

**Bibliography.**—Adeney, W. E., 'Ezra, Nehemiah and Esther' ('Expositor's Bible,' New York 1893); Batten, L. W., 'The Books of Ezra and Nehemiah' ('International Critical Commentary,' New York 1913); Davies,

T. W., 'Ezra Nehemiah, and Esther' ('Century Bible,' Edinburgh no date); Ryle, H. E., 'Ezra and Nehemiah' (Cambridge Bible, Cambridge 1897). See also the list under **CHRONICLES**.

GEORGE R. BERRY,

*Professor of Old Testament Interpretation and Semitic Languages, Colgate University.*

**EZRA CHURCH** (Atlanta), **Battle of.** On 20 July 1864 the Confederate army under General Hood was defeated at Peach Tree Creek, and driven into the inner defenses of Atlanta. On the 22d Hood attacked the Army of the Tennessee, and was again defeated, and General Sherman began the investment of Atlanta. He began to force Hood from Atlanta by moving upon his communications leading south from the city. The Army of the Tennessee was transferred from the extreme left of the investing line to the right, near Ezra Church, and Hood took measures to check its further extension and drive it back. On the night of the 27th he marched out of Atlanta with the greater part of his force, and on the 28th Gen. J. C. Brown's division was ordered to attack Logan's corps, then advancing on the right, and drive it back to and beyond Ezra Church. Brown drove in Logan's skirmishers, followed them 500 to 600 yards, and struck Logan's right, carried it at some points, but was quickly repulsed with great slaughter. He made a second attempt with no success and fell back. He had lost 694 killed and wounded and 113 missing. During Brown's attack four regiments from Dodge's and Blair's corps extended Logan's right, and took part in the action. Clayton's division attacked on Brown's right, but not until after Brown's first repulse, and by a misunderstanding his three brigades made isolated attacks upon Harrow's division, all of which were repulsed with great loss, some of the regiments losing 50 per cent. Walthall had led out his division while Brown and Clayton were engaged, and at 2 P.M., after they had been withdrawn, he was ordered to attack over the ground of Brown's fight. Walthall made several persistent efforts, but failed, although some parts of his force got within 50 yards of Logan's line. After more than an hour's severe fighting, in which he reports the loss of 152 officers and nearly 1,000 men, he fell back. At night Hood withdrew his troops to the works around Atlanta. The Federals in this battle numbered about 13,000 men; the Confederates about 18,000. The Union loss was 559 killed and wounded, 73 missing. The aggregate Confederate losses were apparently about 2,636 killed and wounded, and 200 missing. The estimates of Generals Sherman, Howard and Logan that the Confederate loss was from 5,000 to 7,000 are excessive. Consult 'Official Records,' (Vol. XXXVIII); Cox, 'Atlanta'; Sherman, 'Personal Memoirs' (Vol. II); The Century Company's 'Battles of the Civil War,' (Vol. IV).

E. A. CARMAN

# F

**F** the sixth letter of the English and Latin alphabets and all alphabets derived from the Latin. Its sound, technically called a "labiodental voiceless spirant," is produced by bringing the lower lip into loose contact with the upper teeth, the vocal cords being inactive. The character F, though it does not appear in the Greek alphabet of the classic period, had a place in the earlier Greek alphabet, and is believed to have there represented the sound of *v* or of *w*. It is called by Greek grammarians, digamma or double-gamma, being formed of two gammas (g hard, Γ) written one above the other (F). From the Greek it came into Latin and, finally, was used to express the sound which it has for us. That the sound of F in Latin was the same as in English, we know from what Quintilian says of the mode of uttering it. The Greek letter Φ (phi) represented in Latin and English by *ph*, appears to have been very different in sound from the F of the Latins; and that in the pronunciation of F Greeks found great difficulty is known on the authority of Cicero; their difficulty was like that which people of other speech than ours find in pronouncing *th* in *then*, *this*, and in *thin*, *think*. A like difficulty in pronunciation of the F of Latin must have presented itself to the inhabitants of the Spanish Peninsula, if not in the time of the Roman domination, then after; else the initial F of words from the Latin would not have been so generally changed by them into a mere breathing, represented by the letter *h*. Examples Lat. *faba* (bean), Span. *haba*; *fabulari* (to talk), *hablar*; *facere* (to make), *hacer*. In other languages, whether derived from one another or springing independently from a common original stem, as German, Anglo-Saxon, Greek, Latin, Celtic, etc., we see a different interchange as between F and P; thus to the English word fish answers the Latin *pisc* (*piscis*); to Eng. fire the Gr. *pyr*; to Eng. plow the Ger. *pflug*. In the local dialect of the English county of Somerset, F usually becomes V: fair becomes vair, friar vrier, five vive. As the Latin alphabet had but one character, V, to represent both the vowel U and the consonant V (or W) the Emperor Claudius ordered that in public inscriptions and state documents this consonant V should be represented by the F inverted,  $\nabla$ , and hence in monuments of that reign we find AMPLIA  $\nabla$ IT, TERMINA  $\nabla$ IT, OCTA  $\nabla$ IA, etc., for Ampliavit, Terminavit, Octavia, etc. The letter F in physics is a contraction for Fahrenheit.

**F. F. V's** (First Families of Virginia), a jocular term applied in the North, before and during the war, to the Southern aristocracy in general.

**FA**, *fā*, the name given by Guido to the fourth note of the natural diatonic scale of C, that is, the subdominant. In the major scale of C this tone is F.

**FABELL**, Peter, the chief character in 'The Merry Devil of Edmonton,' who sold his soul to Satan, and is said to have been derived from a real personage who died and was buried at Edmonton, Middlesex, in the reign of Henry VII (1485-1509).

**FABENS**, Joseph Warren, American miscellaneous writer: b. Salem, Mass., 23 July 1821; d. New York, 13 March 1875. Among his works are 'The Camel Hunt,' a narrative of personal adventure; 'Facts about Santo Domingo'; and 'The Last Cigar,' a book of poems.

**FABER**, *fä'bër*, Frederick William, English theologian and hymn writer: b. Calverley, Yorkshire, 28 June 1814; d. Brompton, London, 26 Sept. 1863. He was a nephew of G. S. Faber (q.v.). He was educated at Balliol College, Oxford, where he came under the influence of John Henry Newman (q.v.), whom in 1845 he followed into the Roman Catholic Church. On becoming a Roman Catholic he founded a small community called Brothers of the Will of God, who three years later joined the oratory of Saint Philip Neri. He afterward established a branch of this oratory at Brompton, with which he was connected till his death. His prose writings are numerous, but it is by his beautiful hymns that he is best known. Of these 'Pilgrims of the Night' and 'The Land Beyond the Sea' are the most noted. See 'Life and Letters,' edited by Bowden (1869).

**FABER**, *fä'bër*, Frederik, Danish zoölogist: b. Odense, Fünen, 1795; d. 1828. He was graduated in law in 1818, but had also given great attention to zoölogy and at 20 published 'Indledning til Dyrelæren til Brug ved den Naturhistoriske Undervisning.' He traveled in Iceland in 1819-21, and published the results of his investigations in 'Ueber das Leben der hochnordischen Vögel Islands' (1826), a work still of value; 'Prodromus isländischer Ornithologie' (1822); 'Naturgeschichte der Fische Islands' (1829), and articles in *Isis* and in *Tidskrif for Naturvidenskaberne*. Several zoölogical species are named from Faber.

**FABER**, George Stanley, English theologian: b. Calverley, near Bradford, Yorkshire, 25 Oct. 1773; d. near Durham, 27 Jan. 1854. Having been Bampton lecturer in 1801, he shortly after published his lectures under the title of 'Horæ Mosaicæ.' From the first he adopted evangelical views, and soon began to aid them by his pen, particularly by 'The Doctrine of Regeneration in the Case of Infant



Baptism.) He was vicar successively of Stockton-upon-Tees, Redmarshall and Longnewton, holding the last appointment 21 years, when he resigned it to become master of Sherburn Hospital. His principal writings, in addition to those already mentioned, are 'A Dissertation on the Prophecies,' the most popular of all his works, and the 'Difficulties of Romanism,' of which a third edition appeared in 1853.

**FABER**, or **FABRI**, Jacques Lefèvre d'Estaples, French scholar: b. Estaples (Estaples), near Boulogne, about 1450; d. 1536. He was educated at the University of Paris and for a time taught in the College of Cardinal Lemoine. He visited Italy and in 1507 was given a home in the Benedictine Abbey of Saint-Germain-des-Prés by his friend Abbot William Briçonnet. Faber remained there for 13 years, becoming in 1520 director of the leper hospital of Meaux. Faber's writings displeased several high church officials but he was safe from persecution through the protection of Francis I. When the latter was taken prisoner in 1525 Faber was formally condemned. On Francis' return he was made royal librarian at Blois and tutor to the king's children. Princess Margaret, on becoming Queen of Navarre, took Faber to Nérac, where he spent his last days in peace. His works were numerous and included a French translation of Saint Paul's Epistles (1512), of the New Testament (1523), of the Pentateuch (1528) and the whole Bible in 1530. Consult the life by De Labatier Plantin (Montauban 1870) and that by Prossdij (Leyden 1900).

**FABER**, Johann Lothar von, German manufacturer: b. Stein, near Nuremberg, 12 June 1817; d. 1896. In 1860 he founded in his native town a manufactory of lead pencils, with only 20 hands employed. He made so many improvements in the manufacture that his factory gradually became the centre of that particular industry, and absorbed the trade of Germany and Austria. Particularly successful and profitable was the making of pencils of different grades, while his business capacity in distributing his goods did much to promote their popularity. He opened branches in the great cities of Europe and the United States. He was ennobled for his services to German industry. He established a plant in New York with a cedar yard and mills at Cedar Keys, Fla.; and in his factory at Noisy-le-sec, near Paris, over a thousand operatives were employed.

**FABER**, Johannes. See **FABRI**, **JOHANNES**.

**FABIAN**, fā'bi-an, belonging or relating to the famous Roman family, or clan, the Fabian used especially in the military phrase Fabian tactics, to denote tactics the chief point of which is to weary and exhaust the enemy. By such measures Quintus Fabius Maximus, surnamed Cunctatus ("the delayer") greatly harassed Hannibal in the Second Punic War.

**FABIAN SOCIETY**, an English socialistic organization, founded in January 1884, having its headquarters in London, and with affiliated branches in most of the principal cities and towns of Great Britain and Ireland. The society includes in its ranks some very prominent writers on social economy, including George Bernard Shaw and Sidney Webb, and publishes 'Fabian Essays' and 'Fabian Tracts.'

In 1888 they began to hold public meetings. Above 700 lectures have been given in one year by members of the society. The Fabians aim to bring about the "emancipation of land and industrial capital from individual and class ownership and the vesting of them in the community for the general benefit"; "the extinction of rent"; and "the transfer to the community of the administration of such industrial capital as can be conveniently managed socially." They also advocate female suffrage. The recently formed research department has added to the society's activities. There is a society of the same name in the United States, which issues a periodical called the 'American Fabian.' Consult Shaw, G. B., 'The Fabian Society' (1892).

**FABII**, fā'bi-i, Arch of the, a commemorative arch in ancient Rome at the entrance of the Sacred Way (Via Sacra) to the Forum Romanum. It was constructed about 120 B.C. by Quintus Fabius Maximus Allobrogicus in celebration of his victories over the Allobroges and Arverni. Its material was the calcareous Italian rock called travertin, and its design simple. Some few of the travertin blocks were excavated in 1882 not far from the site of the arch. Consult Platner, 'The Topography and Monuments of Ancient Rome' (1911).

**FABIUS**, fā'bi-us, the name of one of the oldest and most famous families of Rome, every member of which was massacred at Cremera 478 B.C., except **QUINTUS FABIVS VIBULANUS**, who became one of the decemvirate. Among the most noted of the family in later times are: **FABIUS AMBUSTUS**, dictator, 350 B.C.; **FABIUS RULLIANUS**, to whose name **MAXIMUS** was added, twice dictator, conqueror of the Samnites and Etruscans, 323-280 B.C.; **FABIUS GURGES**, son of the preceding, consul of Rome; **FABIUS PICTOR**, the first writer of Roman history, 3d century B.C.; **FABIUS MAXIMUS VERRUCOSUS**, considered the greatest of his family, surnamed "Cunctator," "the Delayer" (see **FABIAN**), from his system of warfare, died 203 B.C.; **FABIUS MAXIMUS QUINTUS**, son and next in office to the preceding, afterward consul; **FABIUS MAXIMUS ÆMILIANUS**, distinguished in the war of Persia and in Spain, consul 147 B.C.; **FABIUS MAXIMUS SERVILIANUS**, pro-consul for Spain, censor 126 B.C.; **FABIUS MAXIMUS ALLOBROGICUS**, consul 122 B.C.

**FABIUS**, The American. Name often given in the last century to George Washington, because of his habit of avoiding pitched battles after the manner of Fabius Cunctator.

**FABLE** (Lat. *fabula*, a narrative, especially a fictitious one), in literature, a term applied originally to every imaginative tale, but confined in modern use to short stories, either in prose or verse, which are meant to inculcate a moral lesson in a pleasant garb. Imaginary persons, animals and inanimate objects are introduced as the actors and speakers. The fables consist properly of two parts—the symbolical representation and the application or the instruction intended to be deduced from it, which latter is called the moral of the tale, and is indispensable to it.

Herder divides fables into (1) Theoretic, intended to form the understanding; thus a phenomenon of nature, as illustrative of the

laws of the universe, is used to exercise the understanding. (2) Moral, which contain rules for the regulation of the will. We do not learn morality from the brutes, but view the great family of nature, and observe that she has connected the happiness of all living creatures with the unchangeable, eternal law of effort, and take example from the observance of this law by the lower orders of creation. (3) Fables of fate or destiny. It cannot always be made evident how one thing follows as a necessary consequence from another; here then comes in play that connection of events which we call fate, or chance, and which shows that things follow, at least after, if not from one another, by an order from above. Thus the eagle carries with her plunder a coal from the altar, which sets fire to her nest, and thus her unfledged brood becomes the prey of animals which she has already robbed of their young.

The oldest fables are supposed to be the Oriental; among these the Indian fables of Pilpay or Bidpai, and the fables of the Arabian Lokman, are celebrated. Æsop is well known among the Greeks, and was imitated by Phædrus among the Latin writers. Bodmer has published German fables of the time of the Minnesingers. The first known German fabulist is Stricker, who belongs to the first half of the 13th century, but the famous mediæval beast-epic of 'Reinecke Fuchs' (see REYNARD THE FOX) has a much more remote origin. Boner, who lived at the close of the 14th century, shows in his 'Edelstein' the true spirit of fable. Burkard Waldis may be mentioned in the 16th century. The most successful of German fable writers is undoubtedly Lessing. In the 17th century Gay among the English, and La Fontaine among the French, were distinguished. The writer last named made fable the vehicle of wit, and carried it to its highest stage of perfection. Among the most interesting modern productions in this department of literature the fables of the Russian, Ivan Kriloff, deserve special mention. See ALLEGORY; MYTH.

**FABLE OF THE BEES.** A satire on the state of English society, first published in 1705 in 200 doggerel couplets, under the title of 'The Grumbling Hive or Knaves Turn'd Honest.' It was republished anonymously in 1714 with 'Remarks' and an 'Enquiry into the Origin of Moral Virtue.' Another edition appeared in 1723 with the addition of an 'Essay on Charity and Charity Schools' and 'A Search into the Nature of Society.' This edition gave great offense and was indicted as a "public nuisance" by the grand jury of Middlesex, this action by the authorities giving it considerable notoriety. Satirizing the government and attacking the idealism of Shaftesbury, its sarcastic philosophy and pessimistic counsel were not improved by the author's cynical assertion that he was writing for "the entertainment of people of knowledge and education." See MANDEVILLE, BERNARD DE.

**FABLE FOR CRITICS, A.** Lowell's 'Fable for Critics,' though considered by the poet himself a mere *jeu d'esprit*, is the best-known and the most successful literary satire in verse by an American. It was written at intervals between November 1847 and July 1848, and was published in October 1848. Its 1,700 lines of galloping anapæstic tetrameter, an ad-

mirable vehicle for its purpose, present a mixture of rollicking fun, satire and panegyric. Its title states its purpose. Lowell saw American literary criticism as often unfair and even foolish and over-dependent on British opinion. His fable presents Apollo, god of poets, delivering Olympian judgment, supposedly unbiased and final, upon American writers; and this fable is addressed to prejudiced and incompetent critics and to the undiscerning public. Perhaps a score of the best-known writers of the day are passed upon, with scarcely a verdict so severe as not to be tempered with commendation, and scarcely any praise that is not edged with a little raillery. Though written early in Lowell's career, the poem shows his characteristic independence in literary judgment, his fearlessness and his common sense. His estimate of the works of Emerson, Longfellow, Whittier, Holmes, Irving, Cooper and Poe, though anticipating the later and, in some cases, the better work of these writers, is remarkably just and has in the main been ratified by posterity. Many of the terse lines stick in the memory: Emerson "a Greek head on right Yankee shoulders"; Cooper, "who's written six volumes to show he's as good as a lord"; Poe,

"With his raven, like Barnaby Rudge,  
Three-fifths of him genius, but two-fifths sheer fudge;  
Who has written some things quite the best of their kind,  
But the heart somehow seems all squeezed out by the mind."

Though Lowell is unfair to Margaret Fuller and overvalues Maria Child and Sylvester Judd, his perspicacity and fairness are in the main as remarkable as his satire and his fun. The course of the fable is constantly interrupted by digressions; by a fling at literary bores; by satire on dependence upon Great Britain; by scathing but humorous denunciation of slavery; and by a noble eulogy of the Bay State.

In its combination of supernatural machinery, anapæstic meter and puns, and its use of all these for the purpose of literary satire, 'A Fable for Critics' is not original. Its predecessors run back for hundreds of years; perhaps its immediate ancestor was Leigh Hunt's 'Feast of the Poets.' But its mixture of humor, satire and panegyric is as original as delightful. It is far too long; its fun grows wearisome; much of its flavor has of course been lost through time; but its youthful and effervescent hilarity carries it along in spite of its faults. It still lives through a few wise and witty or noble and brilliant passages. Poe reviewed the poem in *The Southern Literary Messenger* (February 1849). For the text, with explanatory notes, etc., consult Scudder, 'Complete Poetical Works'; id., 'Russell Lowell, a Biography' (pp. 238-253).

MARION TUCKER.

**FABLES OF ÆSOP,** the collection of old folklore or moralizing animal stories, attributed to the Greek fabulist Æsop (q.v.) who is said to have lived in the 5th and 6th centuries B.C. His reputation is based on these amusingly satirical "beast stories" with an apposite moral, adapted to contemporary events and incidents, which he narrated at banquets and festival gatherings, for the entertainment of guests and visitors. Artless, simple and transparent in construction, affecting no graces of style, the story is the main thing, the moral being always subordinate and never permitted to interfere with the principal theme. Insolent sarcasm, how-

ever, introduced into a fable, is said to have been the culminating incident which led to his assassination at Delphi. As oral productions, he did not commit his fables to writing but they were perpetuated by Xenophon, Aristotle, Plutarch, and other Greek writers. Aristophanes alludes to them as "merry tales" and in the 'Wasps' represents Philocleon as having learned Æsop's "absurdities" from conversations at banquets. Plato in 'Phaedo' represents Socrates as whiling away his last days in prison by versifying some of Æsop's fables "which he knew," and although he excludes poets, Plato introduces Æsop as a moral teacher in his model 'Republic.' A collection of the 'Fables,' probably in prose, in 10 books, is recorded as made by Demetrius of Phalerium 345-283 B.C., for the use of orators; no copy of the collection, however, is known to exist. An edition in elegiac verse is also mentioned by Suidas. The earliest known reliable version of the 'Fables' is that of Babrius or Babrius, who, as related by Crusius, was a Roman and tutor to the son of Alexander Severus; he rendered the fables into Greek choliambic verse in the early part of the 3d century A.D. This version was long known in fragments only, until in 1842 a complete manuscript, now in the British Museum, was discovered by Mr. Minas in a monastery on Mount Athos. Phaedrus, a Thracian freedman, who lived in Rome in the time of Augustus, produced a version of the fables in Latin iambics, making, however, inferior paraphrases and additions, which for a long time cast doubt on their authenticity, until dispelled by an epigraphical discovery at Apulum in Dacia, and critical re-examination of the manuscript. In the 9th century Ignatius Diaconus made a version of 53 of the fables in choliambic tetrameters. Stories from Asiatic sources were added, notably from the Buddhist Jataka folklore of India, and 'Æsop's Fables' as known to-day are derived from the 14th century edition compiled by Maximus Planudes, a monk of Constantinople. Through succeeding centuries, translations were made into almost every known language. Among the curiosities of literature, an early translation from the Babrian edition into Syriac by Syntipas 100 B.C. is mentioned, which Michael Andreopoulos rendered back into Greek. One of the latest translations is that of Douglas (1901) into the Celtic Manx dialect. The fables have also been prolific sources of inspiration for artists which may be said to have culminated in Tenniel's illustrations with their combination of rare artistic power, humorous observation and knowledge of animal life. (See FABLES). Consult Jacobs, J., 'The Fables of Æsop; i. The history of the Æsopic fable; ii. The Fables of Æsop, as first printed by William Caxton, 1484, from his French translation' (New York 1896).

**FABLES OF PILPAY.** See BIDPAI.

**FABLIAUX,** fā-hli-ō (Fr. from the Lat. *fabula*, a narrative, particularly a fictitious narrative), in French literature, the short metrical tales of the Trouvères (q.v.), belonging for the most part in the 12th and 13th centuries. These productions were intended merely for recitation, not for singing, and reflected the life of the period. They originated with the bourgeoisie, made no pretensions to literary merit, embraced all subjects—tales of devotion, sat-

ires on clerical weaknesses and inconsistencies, conjugal mishaps and love episodes—and were generally conceived in a vein of ironical pleasantry, and in which the wit was coarse if pungent. From the fabliaux the short story form is derived. Fabliaux in fact were "merry recitals" to excite laughter, in contradistinction to the songs of chivalry, war and love of the period. They were usually based on a comic incident, real or probable, occurring in everyday human life. They were marked by considerable originality and diversity, and would appear to have been largely modelled on the Æsopic fable and its Asiatic parallels. Several of Chaucer's 'Canterbury Tales' are derived directly from fabliaux; and so are many of the stories of Boccaccio and of other Italian writers. Fabliaux were the forerunners of the 'Hep-tameron,' the 'Cent Nouvelles Nouvelles,' of Rabelais' 'Pantagruel,' of Prior and Swift's productions, and of Balzac's 'Cent Contes Drolatiques.' Fabliaux seldom ran to more than 400 lines; they related an event, the story being the mainspring of the recital, the deductions, inferences or lesson, to be drawn being subordinate or left to the imagination. The 'Poenitentiale' of Egbert in the 8th century condemned the "fabulas inanes" of the period showing that they were in vogue at that date, but the earliest known is that of 'Richeut' which appeared in 1159, a virile picture of the coarse manners and customs of the time. Among the better known writers of fabliaux were Rutebeuf, author of 'Le Sacristan,' 'Frère Denyse' and 'Dit d'Aristote'; also Henri d'Andeli, and Jean de Condé. While the general run of fabliaux are condemned for vulgarity, coarseness and obscenity, they afford valuable pictures of contemporary life and development, and are rich in philological material. The usual male scorn of female "fourberies" or wiles is marked in 'Chicheface et Bigorne,' 'Le Valet aux deux femmes' and 'Le Pêcheur de Pont-sur-Seine'; the medical profession is satirized in 'Le Vilain Mire'; the ecclesiastical, in the 'Prêtre qui dit la Passion,' 'Les Perdrix' and the 'Prêtre aux Mûres'; while marriage is ridiculed in 'Court Mantel' and 'Le Dit de Berenger.' Of pathetic interest is 'Housse Partie,' while of idealistic tendency is 'Le Chevalier de Barizel.' Consult Montaignon, A., and Raynaud, G., 'Recueil général et complet des fabliaux des XIIIème et XIVème siècles' (6 vols., Paris 1872-79); Bédier, J., 'Les Fabliaux' (Paris 1893); Hart, W. M., 'The Fabliau and Popular Literature' (Baltimore 1908).

**FABRE, Amant Joseph,** ä-män zhō-zef fābr, French author: b. Rodez, France, 10 Dec. 1842 (or 1843). A drama, 'Joan of Arc' (1890), made his name most widely known, his other works being largely represented by such books as 'A Course in Philosophy' (1870); 'Washington, the Liberator of America' (1882).

**FABRE, Ferdinand,** fār-dē-nān, French novelist: b. Bédarieux, France, 1830; d. Paris, 11 Feb. 1898. He deals almost exclusively with life in the Cévennes, his native district. Designed for the priesthood, for which he found he had no vocation, his gallery of portraits of French priests was the fruit of a large and deep experience, and is the most noteworthy that has ever been drawn. He published 'Ivy

Leaves,' poems (1853); then the novels, 'The Courbezons' (1862); 'Julien Savignac' (1863); 'My Uncle Célestin' (1881); 'King Ramiro' (1884); and 'Mr. John' (1886). The remarkable novel, 'Abbé Tigrane' (1873), first won him great distinction; 'Lucifer' (1884), portraying the struggle among the clergy between Gallicanism and Ultramontanism, is doubtless his greatest work. Among his shorter stories are 'The Abbé Rietelet' (1891); 'Norine' (1890); 'Germany' (1891), etc. 'My Vocation' (1889) is a volume of leaves from his student diary. Consult Gosse, 'French Profiles' (1905).

**FABRE, François Xavier Pascal**, frān-swā zāv-yā pās-cāl, French painter: b. Montpellier, 1 April 1766; d. there, 16 March 1837. He was a pupil of David and produced in 1787 a painting representing the 'Execution of the Children of Zedekiah by order of Nebuchadnezzar,' for which he received the great prize of the Academy and was sent as a pensionary to Rome. He was believed to have been secretly married to the Countess of Albany, widow of the Young Pretender, who on her death in 1824 made him her sole heir and bequeathed to him valuable MSS. which had been left to her by Alfieri. Fabre gave them to the city of Florence. He was created a baron in 1830.

**FABRE, Hector**, Canadian journalist: b. Montreal, 1834; d. 1910. He was educated at L'Assomption, Saint Hyacinthe and the Collège de Montreal, studied law and in 1856 was admitted to practice. He soon abandoned this profession to enter journalism, becoming editor of *L'Ordre* of Montreal. From 1863 to 1866 he edited *Le Canadian* of Quebec and founded *L'Événement* there in 1869. In 1875 he became a member of the Dominion Senate and seven years later was appointed Paris agent of the Quebec and Dominion governments. In Paris he founded a French-Canadian journal, *Le Paris-Canada*. He was Fellow of the Royal Society of Canada and published 'Esquisse biographique sur Chevalier de Lorimier' (1856); 'Ecrivains Canadiens' (1865); 'Confédération, Indépendance, Annexion' (1871); 'Chroniques' (1877).

**FABRE, Jean Henri**, distinguished French entomologist: b. Saint-Léons, Aveyron, 21 Dec. 1823. In early life he taught school and became professor of natural philosophy at the Collège of Ajaccio and later at the Lycée of Avignon. He is corresponding member of the Institut de France and chevalier of the Legion of Honor. Many years ago he retired to Sérignan, Vaucluse, and in this retreat produced his greatest work. 'Souvenirs entomologiques' (10 vols., 1879-1907). Among his other numerous works are 'La science élémentaire' (1862); 'Histoire de la bûche' (1866); 'Les ravageurs' (1870); 'Premiers éléments de physique' (1875); 'La plante' (1875); 'Les inventeurs et leurs inventions' (1880); 'The Life and Love of the Insect' (1911); 'Social Life in the Insect World' (1912); 'The Life of the Fly' (1913); 'The Mason-Bees' (1914); 'Bumble Bees' (1915).

**FABRE, Marie Joseph Victorin**, French poet: b. Janjac, Ardèche, 1785; d. 1831. At the age of 20 he achieved a brilliant success with 'Eloge de Boileau,' which was crowned by the

Academy. His later works, however, did not bear out his early promise and he died in obscurity. These include 'Discours en vers sur les voyages' (1807); 'Eloge sur Pierre Corneille' (1808); 'La mort de Henri IV' (1808); 'Opuscules en vers et en prose' (1806) and 'Eloge de La Bruyère' (1810). His collected works were issued by his pupil, J. Sabbatier (Paris 1845).

**FABRE D'ÉGLANTINE, Philippe François Nazaire**, fê-lêp frān-swā nā-zār fābr dā-glōn-tên, French dramatic poet: b. Carcassonne, 28 Dec. 1755; d. Paris, 5 April 1794. Having gained the prize of the Églantine in the Floreal games at Toulouse, he assumed the name of that flower as a surname. He now wrote several theatrical pieces, of which however only two, 'L'Intrigue épistolaire' and the 'Philinte de Molière,' were successful. The latter is still considered one of the best character-pieces of the modern French stage. He engaged with ardor in the Revolution, in which he was associated with Danton, Lacroix and Camille Desmoulins. As deputy from Paris to the National Convention, he at first supported moderate principles, but afterward voted for the death of Louis XVI without appeal, and was chosen a member of the committee of public safety. He afterward became suspected by the Jacobins and being condemned to death was executed along with his colleague Danton (q.v.).

**FABRE D'OLIVET, Antoine**, French Provençal writer: b. Ganges (Hérault), 8 Dec. 1767; d. Paris, April 1825. He was one of the earliest leaders of the dialect and racial movement in southern France, and a descendant of Jean Fabre, 'l'Honnête Criminel,' the hero of Fenouillot de Falbaire's famous drama of the same title. He was a mystic, a scientist and an erratic student whose literary food was of the most omnivorous nature. The wide range of his studies and sympathies is shown in the following partial list of his works: 'Notions sur le sens de l'ouïe en général' (1811-19); 'Les vers dorés de Pythagore, expliqués pour la première fois et traduits en vers cumolpiques français' (1813); 'La langue hébraïque' (1816); 'De l'état social de l'homme' (1822-24); 'Le Quatorze Juillet' (drama 1790); 'Toulon soumis' (historical opera in vers libres 1794); 'Le Sage de l'Indoustan' (drama 1796); 'Lettres à Sophie sur l'histoire' (1801) 'Le Troubadour' (1803); 'Cain' (drama 1823). He also published considerable music. His influence in the re-establishment of the Languedoc as a literary tongue was due principally to his philological studies in Provençal.

**FABRETTI, fâ-brêt'tê, Ariodante**, Italian antiquary: b. Perugia, 1816; d. 1894. In 1860 he was appointed to the chair of archæology at Turin and in 1868 became director of the Museum of Antiquities there. He published several works on the antiquities of Perugia and became senator of the kingdom in 1889. His most important work is 'Corpus Inscriptionum Italicarum Antiquioris Ævi' (1867).

**FABRETTI, Raffaele**, Italian antiquarian: b. Urbino; 1619; d. Rome, 7 Jan. 1700. He was made papal treasurer by Alexander VII, and finally superintendent of the archives in the castle of San Angelo, which office he held till his death. Among his writings may be mentioned 'De Aquæductibus veteris Romæ';

'De Columna Trajani'; and 'Inscriptionum Antiquarum Explicatio,' in the last of which much light is thrown on the discoveries made by himself in the Catacombs.

**FABRI, fä'brē, Felix** (German, *Schmid*), German monk: d. about 1502. He entered the Order of Preachers and became lector in the monastery of the order at Ulm. In 1480 he made a pilgrimage to Jerusalem and three years later went as chaplain with Johann von Waldburg to the Holy Land, returning via Cairo, Alexandria and Venice. At Ulm after his return he penned an account of this journey, which remains one of the most important travel narratives of the late Middle Ages. The Latin version is contained in 'Bibliothek des litterarischen Vereins' (Stuttgart 1849). A German version appeared in Feyrabend's 'Reyssbuch des heiligen Lands' (Frankfort 1584).

**FABRI, Friedrich**, German theologian: b. Schweinfurt, 1824; d. 1891. He received his education at the universities of Erlangen and Berlin. He held several pastorates, and in 1857 became director of the Missionary Society at Barmen, where he remained until 1884. He then retired to Godesberg-on-the-Rhine and became president of the Evangelical Society for the German Protestants in America. In 1889 he was appointed honorary professor at the University of Bonn. He wrote 'Bedarf Deutschland der Kolonien?' (3d ed., 1884); 'Briefe gegen den Materialismus' (1856); 'Die Entstehung des Heidentums und die Aufgabe der Heidenmission' (1859); 'Die politische Lage und die Zukunft der evangelischen Kirche in Deutschland' (3d ed., 1874); 'Staat und Kirche' (3d ed., 1872); 'Fünf Jahre deutscher Kolonialpolitik' (1889).

**FABRI, Jacques L. D'Estaples.** See **FABER.**

**FABRI, Johannes**, Roman Catholic prelate: b. Leutkirch, near Lake Constance, 1478; d. Baden, 21 May 1541. He changed his name of Heigerlin to Fabri or Faber, studied theology and canon law at the universities of Tübingen and Freiburg. He served as a member of the secular clergy for several years and in 1518 became vicar-general of Constance. He was on intimate terms with Erasmus, Melancthon and Zwinglius and many thought that he agreed with their doctrines, but when the breach came he remained with the ancient Church. In 1522 he published a work against Luther, and thereafter his opposition to the Reformers was constant and formidable. His 'Malleus in Hæresim Lutheranam' (1524) earned for him the sobriquet of "Hammer of Heretics." He was one of the ablest defenders of the old Church at Zürich in 1523, Speiers in 1529, and Augsburg in 1530. In 1531 he was appointed archbishop of Vienna and thereafter his polemical struggles were with the Moslems. His homiletical works were issued at Cologne (3 vols., 1537-41) and the polemical in 'Opuscula Quædam J. Fabri Viennensis' at Leipzig (1537). Consult Horawitz, A., 'Johannes Heigerlin genannt Faber, Bischof von Wien, bis zum Regensburger Convent' (Vienna 1884); and 'Janssen, 'History of the German People' (Vol. XIV, English trans., London 1909).

**FABRIANO, Gentile da, jen-tē'lā dā fä-brē-ä'nō**, Italian painter: b. Fabriano, about

1370; d. Rome, about 1450. His earliest work was perhaps the decoration of a chapel for Pandolfo Malatesta at Brescia. In 1423 he painted one of his best extant pictures, an 'Adoration of the Kings,' for the church of the Holy Trinity in Florence. To the same period belongs a Madonna with Saints (now in the Berlin Museum). A picture of the naval engagement between the fleet of Venice and that of the Emperor Barbarossa, which Fabriano painted for the Venetian Senate, so pleased them that they conferred on him the dignity of a patrician and a pension of a ducat *per diem* for life. Fabriano next worked at Orvieto, but was called thence by Pope Martin V, who employed him in adorning the church of Saint John Lateran with frescoes from the life of John the Baptist. Fabriano's pictures indicate a cheerful and joyous nature. He had a child-like love of splendor and rich ornamentation, but his coloring is never extravagant or meretricious.

**FABRIANO**, Italy, episcopal city 20 miles northeast of Perugia. It is situated at an elevation of 1,066 feet, in the midst of mountain scenery and in a fruit-growing region. This is the native place of the artist Gentile da Fabriano (q.v.), a large number of whose paintings are preserved here in churches and in the city hall. Paper, parchment, gunpowder, glue and felt-cloth are the chief manufactures. The paper and parchment factories were established in 1564. Pop. of the commune 23,752.

**FABRICE, fä-brēs', Georg Friedrich Alfred von**, German statesman: b. Quesnoy-sur-Deule, France, 1818; d. 1891. He entered the Saxon army in 1834 and rose to chief of the general staff and major-general in 1865. In the war between Prussia and Austria in 1866 he was chief of staff to Crown Prince Albert, who commanded the Saxon troops on the Austrian side. After the war Fabrice was appointed Saxon Minister of War. In this capacity he reorganized the Saxon army after the Prussian model. He was one of the prominent commanders in the war of 1870-71 with France, conducted the peace preliminaries at Versailles and commanded the German army of occupation in France. He again became Minister of War of Saxony in 1871 and Prime Minister in 1876. He was made a baron in 1878 and count in 1884. Consult Dittrich, 'General von Fabrice' (Dresden 1884).

**FABRICIAN (fä-brīsh'än) BRIDGE**, Rome, a stone bridge joining Æsculapius Island with the left bank of the Tiber, built in 62 B.C. by Lucius Fabricius. It is the only Roman bridge that has lasted to our day. It is known at present as the Ponte dei Quattro Capi. Consult Platner, 'The Topography and Monuments of Ancient Rome' (2d ed., New York 1911).

**FABRICIUS, fä-brīsh'ūs, Gaius Fabricius Luscinus**, Roman general and statesman of the 4th and 3d centuries B.C. In 282 B.C. and again in 278 he was consul. In 282 he won a victory over the Lucanians and Bruttians and also led troops against Pyrrhus. He was noted for his incorruptibility. It is said that Pyrrhus once tried to secure favorable peace terms through bribery, but his offer was received by Fabricius with such disdain that Pyrrhus released his Roman prisoners. On another occa-

sion an attendant of the king offered to poison his master for a consideration, but Fabricius informed Pyrrhus of his servant's treachery and the king again released all Romans held as prisoners by him. Fabricius was censor, together with Q. Æmilius Papius. He was awarded a triumph for his military victories, but at his death his means were so slight that his daughter was given a pension from the public treasury.

**FABRICIUS, fā-brēt'se-ūs, Georg,** German scholar: b. Chemnitz, Saxony, 1516; d. 1571. In 1546 he was made rector of Meissen and in 1570 Maximilian II made him poet laureate. His poetry was written mostly in Latin. In 1560 appeared his 'Poematum Sacrorum Libri XV.' Other important works were his 'Antiquitatum Libri II' (1549); 'Itinerum Liber Unus' (1551); and 'Roma' (1551). Consult Baumgarten-Crusius, 'De Georgii Fabricii Vita et Scriptis' (Meissen 1839).

**FABRICIUS, Hieronymus, hī-ēr-ōn'i-mus fā-brish'i-us** (Italian Fabrizio, Girolamo), Italian physician: b. Aquapendente, 1537; d. Padua, 21 May 1619. He studied at Padua under the celebrated Fallopius, whom he afterward succeeded in the anatomical chair, and had Harvey, the discoverer of the circulation of blood, for a pupil. Harvey acknowledged that the discovery of the valves in the veins made by his master put him on the way of his discovery. During the lifetime of Fabricius his merit was fully recognized by the public and the state, an anatomical theatre being built for him at Venice. His works were collected and published by Bohnius (1687).

**FABRICIUS, Johann Albrecht,** German scholar: b. Leipzig, 11 Nov. 1688; d. Hamburg, 30 April 1736. He was versed in almost every department of human knowledge, particularly in philology and ancient literature, and understood the art of using these stores of erudition to the greatest advantage. He was professor of rhetoric and moral philosophy in the gymnasium at Hamburg. He published a 'Bibliotheca Græca' (1705-28); 'Bibliotheca Latina' (1697); 'Bibliotheca Mediæ et Infimæ Ætatis' (1734); 'Bibliotheca Ecclesiastica'; 'Bibliotheca Antiquaria' (1713).

**FABRICIUS, Johann Christian,** Danish entomologist: b. Tundern, in the duchy of Schleswig, 7 Jan. 1745; d. Kiel, 3 March 1808. He pursued his studies at Leyden, Edinburgh and Freiburg in Saxony and under Linnæus at Upsal. His works upon entomology show the principles, the method and even the forms of expression peculiar to Linnæus applied to the development of a new, happy and fruitful train of ideas. From his intercourse with him he derived his first notions of his system of arranging insects according to the organs of the mouth. Fabricius obtained the professorship of natural history in the University of Kiel; and in 1775 appeared his 'System of Entomology,' which gave to this science an entirely new form. Two years afterward he developed in a second work the characters of the classes and orders, and demonstrated in the *prolegomena* the advantages of his method. In 1778 he published his 'Philosophia Entomologica,' written upon the plan of the well-known 'Philosophia Botanica.'

**FABRIKOID,** a material consisting of a base of cotton cloth, coated with a tough, flexible material and embossed by steel plates or rolls to produce the appearance and feeling of any desired natural leather grain. It is made in various grades, colors, widths and grains for different purposes. It is used for the upholstery of automobiles, carriages, furniture, for bookbinding, suitcases, purses, novelties, and in general for all classes of work where leather may be used, such as wall coverings, trunk linings, etc. Fabrikoid is waterproof, washable and non-absorbent, and has the pleasing appearance of the best leather. It is manufactured in rolls, averaging 60 yards in length and 36 to 54 inches in width.

**FABRIZI, fā-brēt'sē, Nicola,** Italian soldier: b. Modena, 1804; d. 1885. In 1831 for his part in the Modena insurrection he was imprisoned. When released he went to Marseilles and with Mazzini organized the Savoy expedition. He went to Spain and took part in the Carlist wars on the Liberal side, and afterward removed to Malta. In 1848 he fomented a revolution in conjunction with Crispi and again in 1860. He joined his forces with Garibaldi at Palermo and by the latter was made Minister of War and governor of Messina. Under a United Italy Fabrizi was elected to the Parliament of the kingdom.

**FABRONI, or FABBRONI, fā-brō'nē, Giovanni Valentino Mathias,** Italian scientist: b. Florence, 13 Feb. 1752; d. Pisa, 17 Dec. 1822. He left behind him a considerable number of valuable memoirs and treatises on matters relating to chemistry, agriculture, physiology, etc., of which the best known are 'Provvedimenti Annonarj'; his 'Discourses on National Prosperity'; on 'The Equilibrium of Commerce, and the Establishment of Custom-houses'; on the 'Effects of the Free Traffic in Raw Material'; on 'Rewards for the Encouragement of Trade'; on the 'Chemical Action of Metals'; on the 'Value and Reciprocal Proportion of Coins'; on the 'Scales and Steelyards of the Chinese,' etc.

**FÁBULAS OF TOMÁS DE IRIARTE.** In spite of the pronounced fondness of the Spaniards for the moralizing and the aphoristic in both spoken and written expression, the fable as a distinct genre did not come to its own in the Spanish language until the 18th century. In translations of both Oriental and Occidental material and sporadically in this or that literary work, in which it is used for literary purposes, the apologue material appears now and then from the Old Spanish period down; but as a form displaying any originality of treatment it first becomes important with the composition of the verse fables of Tomás de Iriarte (1750-91) and of Félix María Samaniego (1745-1801). While Samaniego draws in no slight degree upon the Æsopic stock and does not hesitate to utilize also the Latin Phædrus, the Frenchman La Fontaine, and the Englishman Gay, Iriarte shows far more independence of conception, and besides, as the very title of his work, 'Fábulas literarias' (1782), suggests he has not Samaniego's purpose of edifying the world at large but rather the restricted circle of men of letters. Literary criticism is, then, the compelling motive of the lessons that he frames and seeks to inculcate. He has the set aim of correcting,

through the ridicule which he directs upon them, the various defects from which Spanish literature is suffering. To do this he has no need of giving free rein to his imagination; on the contrary, he has only to give evidence of a sound literary judgment expressed in an easy and correct style and seasoned with a delicate humor. All these qualities are well exhibited in his fables, which, moreover, present a versification of a nature ever varied and ever harmonious. Iriarte's abiding fame is associated with the 'Fábulas literarias,' but it is worthy of record that he was a skilful writer of comedies, in several of which he satirized features of the social life of his time.

J. D. M. FORD.

**FABULOUS ANIMALS.** See **FABLE**; **HERALDRY**; **UNICORN**.

**FABVIER**, fá'vyá', Charles Nicolas, BARON, French general: b. Pont-à-Mousson, 1782; d. 1855. In 1807 at the order of Bonaparte he went to Constantinople to strengthen that city's fortifications in view of an impending attack by a British fleet. After accomplishing this task he organized batteries of artillery for the defense of Ispahan against the Russians. In 1811 he was with Marmont in Spain and two years later became a member of the general staff with the rank of colonel. After the restoration of the Bourbons his political activity soon made a sojourn in England more desirable than to remain in France, and in 1823 he went to Greece and was made commander-in-chief of infantry. Reverses at Chios and at Athens impaired his position among the Greeks, and he returned to his native land in 1829. He was named Ambassador to Constantinople in 1848. He published 'Journal des opérations du VI, corps pendant la campagne de 1814 en France' (1819). Consult Debidour, 'Le général Fabvier, sa vie et ses écrits' (Paris 1892); id., 'Fabvier à l'Acropole' and 'Les dernières années du Général Fabvier' (in 'Séances et travaux de l'Académie des sciences morales et politiques,' Vols. CLIX, CLXI, Paris 1903, 1904).

**FABYAN**, or **FABIAN**, Robert, English historian: d. 1513. He was a member of the Drapers' Company and served as an alderman of London. In 1516 was published his 'New Chronicles of England and France.' He began with the arrival of Brutus and continued the history down to the battle of Bosworth Field in 1485. The work suffers much from the author's lack of scholarship. Fabyan is, however, valuable for his accounts of the London life of his day. Successive chroniclers continued the work down to 1558. Consult the edition by Sir Henry Ellis (London 1811).

**FAÇADE**, fá-sad' (Fr. "the front of a building"), the face or front of any building, particularly its principal face or faces; generally used of a building of magnitude or importance. A back elevation is termed a rear façade; a side elevation a lateral façade. See **ARCHITECTURE**.

**FACATATIVA**, fá'ká-tá'té-vá', Colombia, town in the department of Cundinamarca, 20 miles northeast of Bogotá. Its site is 8,500 feet above sea-level. Facatativá was an Indian fortress before the advent of the Spaniards. The last chief of the Chibchas, Triquesupa, was

killed here in 1538 by one of Quesada's soldiers. The town has considerable trade with Bogotá. Pop. 7,000.

**FACCIOLATI**, or **FACCIOLATO**, Jacopo, yá'kō-pō fá-chō-lá'tē or -tō, Italian philologist: b. Toregia, near Padua, 4 Jan. 1682; d. Padua, 26 Aug. 1769. He devoted the greatest attention to reviving the study of ancient literature; and accordingly undertook a new edition of a dictionary in seven languages, which was called the 'Calepin,' from the name of its author, the monk Ambrosius Calepinus. His pupil, Forcellini, assisted him and the work was completed between 1715 and 1719. He now, in company with his industrious disciple, conceived the idea of a Latin lexicon, in which every word, with all its significations, should be contained and illustrated by examples from the classical writers, after the manner of the dictionary of the Cruscan Academy. This immense undertaking occupied them both for nearly 40 years. Facciolati directed the work, which is generally regarded as having been almost entirely executed by Forcellini. He left many Latin discourses which are characterized by Ciceronian elegance of style, but differ from their model by a precise brevity.

**FACE.** See **SKULL**.

**FACE WHEEL**, called also **Contrate Wheel** and **Crown Wheel**, a wheel which has cogs projecting from the periphery at right angles to the plane of motion; as, in watches, the wheel situated nearest the crown and driving the balance.

**FACETIÆ**, fá-sē'shī-ē (Lat. "witticisms"), a collection of humorous sayings or tales, witticisms and jests. Among the earliest such is that known as 'Asteia,' generally attributed to Hierocles. Latin collections were common in the later Middle Ages, the most notable being the 'Liber Facietiarum' (1470) of Poggio Bracciolini.

**FACHAN**, or **FATSHAN**, China, in the province of Kwang-Tung, on the Tu-Kiang, about 20 miles west by south of Canton. Its iron and steel products have earned for it the name of the "Birmingham of China"; it has manufactures also of cloth and silk, bamboo and rattan articles, embroideries and porcelain. Its trade is in manufactured articles and the agricultural products of the surrounding country. Pop. 450,000.

**FACIAL ANGLE**, an anatomical term for the angle contained between two imaginary lines, one from the most prominent part of the forehead to the anterior extremity of the alveolar process of the upper jaw, opposite to the incisor teeth; the other from the external auditory foramen to the same point, serving to measure the elevation of the forehead. The angle is of great service in ethnology, but its magnitude is not an infallible criterion of the intellectual capacity of an individual. It is sometimes called Camper's angle, because the celebrated Dutch anatomist Camper was the first to draw attention to the importance of this method of skull measurement.

**FACIAL NERVE.** The seventh cranial nerve in the cerebro-spinal axis forms the chief motor nerve of the face. It originates in a group of ganglion cells lying in the floor of the fourth ventricle in the medulla. The fibres

pass out through the temporal-bone lying by the side of the auditory nerve in the middle of the ear canal and are finally distributed to the chief muscles of the face. Affections of this nerve cause partial or total loss of power of the muscles of the face. See **FACIAL PARALYSIS**.

**FACIAL NERVE PARALYSIS**, paralysis of the motor nerve which controls the muscles of the face. The paralysis may extend to one or both cheeks; but, in most cases, when the cause has been treated recovery follows.

**FACIAL NEURALGIA**, a painful affection involving the chief sensory nerve of the face; the trigeminal or fifth nerve. This neuralgia may involve any of the branches and, because of their wide distribution over the shoulder, back of the neck, scalp and face may be felt in a number of locations. Very frequently the pain is in the jaw and is due to diseased teeth, toothache being a form of neuralgia of this nerve.

The pain may radiate from over the orbit, constituting supra-orbital neuralgia, or it may be distributed over the back of the head, constituting occipital neuralgia. Occasionally neuralgia of the fifth nerve gives rise to typical attacks of sick-headache. A particular variety which is extremely severe and is supposedly due to disease of the sensory ganglia of the fifth nerve is known as *tic-douloureux*. Characteristic features of neuralgias of the face are the sudden shooting, darting pains, usually one-sided, unaccompanied with other constitutional disturbances. The cause is most frequently exposure to cold. From riding on the tops of omnibuses, sitting by the open windows of railroad cars, or by any open window with a draft blowing through, persons are very frequently affected. At times anæmia, gout and infection from bad teeth occasion facial neuralgia.

Treatment will depend largely upon the exciting cause. Heat, gentle massage, simple diet and free movements of the bowels are general measures to be carried out. Occasional surgical intervention is necessary to cure *tic-douloureux*. The medical treatment of neuralgias of the face is technical and involves the use of remedies that are dangerous in the hands of laymen.

**FACIAL PARALYSIS**, a partial or total loss of power in the muscles of the face. One side of the face alone is usually affected. Paralysis may result from any disease of or injury to the facial nerve, either inside of the skull proper, or in its external distribution. Paralysis of the face very frequently occurs in apoplexies. Here the disease results from a disturbance of the nerve in its intracranial portion. It also is occasioned by disease in the middle ear, but is most frequent following exposure to cold, during which the external branches are involved. This latter form is termed Bell's palsy (q.v.). The symptoms of facial paralysis may vary according to the number of branches of the nerve that may be involved. In a complete case the paralyzed side is flat and expressionless, the mouth is drawn toward the well side, making the well side look as though it were contorted and diseased. The patient is unable to whistle and may not be able to talk very clearly. The tongue may be protruded toward the well side. There may be

inability to close the eyelids. Sensation is not involved. When the patient eats he may not be able to move the tongue on the paralyzed side of the mouth and he cannot fill out his cheeks on the flat side. The electrical reactions of the muscles at first may not be affected, but later what is known as the reaction of degeneration sets in. Most cases of facial paralysis due to peripheral trouble, as well as Bell's palsy, recover of themselves; others, due to hemiplegia or to inflammation of the middle ear or to fracture of the skull, recover less frequently.

Treatment is by means of tonics—iron, strychnine, arsenic and electricity. In intractable cases surgical anastomosis with other motor nerves may prove of service.

**FACIAL SPASM**. See **TICS**.

**FACINGS, Military**. See **UNIFORMS**.

**FACSIMILE**, fāk-sim'ī-lē, an exact reproduction or likeness, as of handwriting, printed books, manuscripts, etc.

**FACTOR** (Lat. "a maker"). (1) An agent or substitute, especially a steward or agent of an estate, appointed by a landowner to manage the estate, collect rents, let lands, etc.; also an agent employed by merchants to transact business for them in other places, as to buy and sell, to negotiate bills of exchange, etc. He differs from a broker in that he is entrusted with the possession and disposal of the goods, property, etc., and may buy and sell in his own name. (See **AGENT**). (2) In arithmetic any one of the integers the product of which is a given number. A prime factor is a factor which is also a prime number. (3) In algebra, any one of the quantities which, when multiplied, produce a given algebraic expression.

**FACTOR ACTS**. A term applied to a number of American and English statutes validating sales, pledges and other business transactions of factors with bona-fide purchasers, pledgees, etc. Among the English statutes were those enacted in 1823, 1842, 1877 and 1889. The last-named statute in part extends the former statutes and in part re-enacts them. Many statutes having practically the same effect as those of England have been enacted in the United States. These acts were deemed necessary to relieve the extreme hardships often resulting from the application of the common-law doctrine that the purchaser buys at his peril, the vendor giving no better title than he has himself. This frequently resulted in the perpetration of numerous frauds by unscrupulous persons on innocent purchasers, pledgees and the like. By the terms of these acts any agent having possession of goods or the bill of lading, warehouse keeper's certificate, or other document of title, with the consent, actual or apparent, of the real owner, should be deemed to be the owner of the goods for the purpose of validating any lien, pledge or the like, made bona-fide by any person with such agent and for payments and advances made on the security of the goods or evidences of title thereto. It was further provided by some of these acts that such contracts were to be binding upon the real owner of the goods and all persons interested therein, even if the purchaser, pledgee or the like was aware of the fact that the person with whom he dealt was the agent and not the real owner. The tendency of recent legis-



lation, both in England and in many jurisdictions in the United States, is toward extending the scope of the law in the direction of an entire abrogation of the common-law doctrine on the subject of contracts made with agents or others having possession of personal property or evidences of title thereto with the permission, real or apparent, of the owner. The principal by these statutes is compelled to use caution in the selection of persons who represent him in business transactions, as ordinarily third persons dealing bona-fide with such representatives will be protected. In a few States, however, persons dealing with agents, knowing them to be such, will not be protected. In a number of States factor acts restrict the doctrine to mercantile transactions and in other States the acts provide that the goods must have been entrusted to the agent for the purpose of sale in order to validate contracts made in relation thereto. See AGENT; CAVEAT EMPTOR; FACTOR.

EDWARD F. DONOVAN.

**FACTOR OF SAFETY.** See STRENGTH OF MATERIALS.

**FACTORIES AND FACTORY INSPECTION.** The American factory in the early days of the Republic was an outgrowth of the English factory. In the 18th century England was the centre of the world's mechanical progress. She manufactured not only for Great Britain and her colonies, but for a large part of the rest of the civilized portions of the globe. Early emigrants to America were not allowed to bring tools and machines for manufacturing and the laws of the mother country also aimed to hold skilled workmen. The result was that the immigrant weaver who sought to follow his trade in the New World when without a loom built one; the printer who wished to issue a newspaper had to build his own press; the tanner had to make his own vats and the currier to fashion his own beaming knife and table.

Because of these conditions American mechanics had to build largely from the very foundation and thus they became inventors and designers of machinery and introduced many improvements that otherwise might not have seen the light. The textile industries were the first to develop here; then came the iron mills, the flour and grist mills and the machine shops. At the close of the Civil War in 1865 the United States was a land of small shops, with here and there a factory of modest proportions. The war had given a great stimulus to the machine shops and when it was no longer necessary to turn out rifles and cannon, the machine men turned their attention to the mechanisms of peace. The reaper, the sewing-machine, the locomotive, the printing-press, the paper-machine, the roller-mill for flour and a thousand other mechanisms were developed and perfected and the shops grew into factories and gradually all New England, the Middle and later the Western and Southern States built factories of all kinds, thousands of which have grown to enormous proportions. New York City alone has over 10,000 factories and the 'Industrial Directory of New York State' is a book of 787 pages. In 1916 there were 285,000 factories in the United States, of which 46,000 were in New York State. The factory has become the backbone of our Western civili-

zation. Here work is reduced to a scientific system and goods are manufactured at a fraction of the cost of former times. If the public pays as much for some things, it is because they demand so much better than formerly. The culmination of success in factory production is seen in the automobile. A better automobile is sold to-day for less than \$400 than could be bought in 1906 for \$1,500.

Factory methods have become so perfected in this country that construction engineers now make a specialty of factory buildings, usually confining themselves to one or more lines of industry and lay out the new buildings from the very foundations according to the most approved practice. Starting with the principle that the cube gives the most working space for the least cost of enclosure, the factory engineers go on to figure what height of story and how many stories are most economical for a given business. They lay out buildings with a view to the handling of a certain class of work to best advantage, that the different departments may move the unfinished work in the least wasteful manner and have the best conditions for good and rapid production. The sanitation and comfort of employees receives marked attention, as the principle is now well established that it pays the factory to keep the good will of its help.

The human element of the factory receives quite as much attention as the mechanical. Efficiency engineers have studied this problem from every angle and all large factories that pretend to scientific management now give close attention to methods of inspiring the workers to get results. Experimental departments are maintained to improve the machinery and processes. Elaborate systems of cost-finding and scientific estimating are common. Specialists are found everywhere in all kinds of factories, improving and systematizing, and there appears to be no end of development of these huge working machines, built up of combinations of men and machines all working toward the common end of turning out the largest quantity of a given product of the best quality in the least time.

**English Factory Development.**—By the middle of the 18th century the first English factory, in the present sense of the word, was built by Lombe Brothers. It was a silk-mill and the first in which the motive power was supplied from the outside and machinery did the work heretofore supplied by human hands. The power used was a water wheel. Arkwright came to the front with his water-frame, so-called, because water was the motive power. There began a rapid development in spinning machines, which were first applied to cotton, and in this industry we have the explanation how the earlier triumphs of the factory system were won. In the beginning of the 19th century, the modern factory system became established and the child-labor question arose. As the mills were first established by the streams, so that wheels might be moved by water power, it often happened that labor could not be had in the vicinity. Application was made to the almshouse for children who were indentured or bound out at a fixed rate and for a certain length of time. Forced to work whether sick or well, often 16 hours a day and given nothing for breakfast but water porridge, these children were visited

with serious epidemics and the attention of the public was thus aroused. In 1802 the first factory act for the "Preservation of the health and morals of apprentices in cotton mills" was introduced by Sir Edward Peel, one of the large manufacturers of that time. All mills employing three or more apprentices, or 20 other persons, were subject to this act. The most important clause was that which fixed 12 hours as a working day and prohibited work altogether from 9 P.M. to 6 A.M.

**First United States Cotton Factory.**—In the earlier years of the factory in the United States, each home had its spindles and loom to fill the needs of its own members, the flax and cotton being grown, spun and woven by the individual householder, or the slaves on the plantations. England frowned upon all manufactures in her colonies and would allow no machinery or parts of machinery to be brought to them. However it could not fetter the brain, nor forbid the inventive genius; and Slater and his associates, who came to America in the latter part of 1700, brought with them the knowledge which in 1803 built in Massachusetts the first American cotton-mill. The first mill to take cotton in its crude state and pass it through the different processes to the woven cloth was erected in Waltham, Mass., in 1813. The first type foundry was built in Philadelphia in 1794. The first glass-house was constructed in Pittsburgh in 1796. Other factories followed in rapid succession between 1796 and 1810.

**Inspection Began in England.**—The first factory inspection law was adopted in England about the beginning of the 19th century, as a result of the agitation caused by epidemics among children and women in factories, but it was not until 1819 that the law was made effective. The abuses became so great that the government was at last compelled to interfere in the interests of humanity. This began by asserting the right of the state to control industrial establishments where women and children were employed, but this necessarily involved the freedom of men in making contracts. The law was intended more particularly to meet the evils of the apprentice system, but it did not extend to factories, where children residing in the neighborhood were employed. From time to time this act has been amended and the authority of government extended, so as to make it generally effective for the protection of all labor. It was thus in England that the value of factory inspection was first determined by experience. Subsequently it was introduced into America. Massachusetts was the first American State to adopt a law of that character.

To-day there are factory laws in the United States based on the Massachusetts laws, for the examination and approval of plans of factories and tenement-houses, also for proper fire-fighting, means of egress and sanitary provisions; regulating the employment of labor of women and minors in manufacturing, mechanical and mercantile establishments and workshops; guarding of machinery; the construction of safety appliances of elevators; ventilation of factories and workshops; provision of toilet conveniences for the use of each sex employed in factories and workshops and various other sanitary regulations; uniform hours for meals for women and young persons; communication between the engineer's room and each room where

machinery is run by steam; proper safeguards at hatchways, elevator openings and well-holes in public buildings, factories and mercantile establishments; competent watchmen and red lights in hotels; prohibiting during working hours the locking of any inside or outside door of any building where operatives are employed; weekly payment of wages; and sundry other matters; the granting of licenses to make, alter, repair or finish coats, vests, trousers or wearing apparel of any description in a room or apartment in a tenement or dwelling house; the examination of engineers and firemen and the inspection of boilers, granting of licenses and steam power to be used. Women are protected by law from overwork by their employers and children are excluded from factories until of proper age and Massachusetts has been from the first, and continues to be, in the advance in factory inspection and under this system her industrial establishments have become models for all the other States. It is a marked illustration of what such a law accomplishes for a community.

The New York State Department of Labor has a Bureau of Factory Inspection and sends out a large force of inspectors to see that the laws for the protection of employees are enforced.

**International Association of Factory Inspection.**—The International Association of Factory Inspection was organized at Philadelphia in 1886 and includes Canada and the States of Massachusetts, New York, New Jersey, Pennsylvania, Rhode Island, Connecticut, Maine, Michigan, Ohio, Minnesota, Illinois, Wisconsin, Missouri and Indiana. Each of these several States holds an annual convention of its inspectors, who meet to compare notes of their work for the year and as their proceedings are made public, each State may know the advancement the other is making in its labor laws.

In 1876 an act was passed in Massachusetts prohibiting the employment of children under 10 years of age. In 1883 the limit was extended by providing that no child under 12 years of age should be employed during the hours in which the public schools were in session. In 1898 the limit was raised to 14 years, providing that no child under 14 years of age can be employed at any time in a factory, workshop or mercantile establishment and no child under 16 years of age can be employed in a factory, workshop or mercantile establishment unless the employer procures and keeps on file a certificate and posts near the principal entrance a list of all such children employed. States that have adopted the factory inspection system have similar child labor laws, differing as to their age, to the age limit when they can be employed.

**The Fifty-Eight-Hour-Law.**—In the State of Massachusetts children under 18 years and women cannot be legally employed more than 58 hours in a week in a factory, workshop or mercantile establishment and every employer must post in a conspicuous place the number of working hours each day of the week, the hours allowed for meals, the hours when starting and stopping work and it becomes a part of the inspector's business to see that this is faithfully complied with. This has been the law of the State since 1894. Other States have enacted similar legislation.

In 1912 the United States Congress estab-

lished a Commission on Industrial Relations to look into conditions in the principal industries of the country and to report upon all the problems growing out of the factory system. There is also a United States Bureau of Labor Statistics and, in 1916, 40 of the States maintained labor bureaus, many of which pattern their work after the Massachusetts Board of Labor and Industries. Eight-hour laws now exist in nearly all the States, providing for a limit of eight hours in work for State and in some occupations, as mining.

**Sanitary Provisions in Factories and Workshops.**—The laws of most States now provide the most rigid sanitary regulations in the interest of comfort, decency and health. These relate to factories, workshops, mercantile establishments, offices, schoolhouses and public buildings. It is required that these buildings shall be kept free from all effluvia arising from drains and that they shall have a proper number of water-closets provided for persons of each sex. It is also provided that during working hours these buildings shall be ventilated, that the air may not become injurious to the health of the persons employed therein. It also provides that all dust from the grinding or polishing of metals be carried away through suction pipes.

**The Inspection of Boilers and Engineers' Licenses.**—The Massachusetts law which has been copied in many States provides that "It shall be unlawful for any person to have charge of, or to operate a steam-boiler or engine, except boilers and engines of locomotive motor-road vehicles, boilers in private residences, in apartment houses of less than five flats, boilers under the jurisdiction of the United States, boilers used for agricultural purposes exclusively, boilers of less than eight horsepower and boilers used for heating purposes, limiting the pressure to 15 pounds to the square inch, other than these boilers above excepted; the person in charge must hold a license granted after a thorough examination by the inspectors appointed for this duty, who are expert engineers."<sup>9</sup>

**The Sweatshop System.**—With the introduction of the sweating system in the United States came a revolution in the clothing industry which has left in its wake destruction and poverty; for prior to the introduction of this system there was not, as a class, a better-paid people than those engaged in the ready-made clothing trade. Looking backward only a few years we have the recollection of a movement in sympathy with a people who were being driven from Russia and other European countries. The first duty upon arrival was to procure means to provide food and shelter for themselves and families, and, being without funds, the task became a very complicated one. The inducement to learn a good trade was freely offered them, provided they would work cheap enough to warrant a sufficient return for the knowledge bestowed upon them. The custom in vogue was that the apprentice should give from one to three months at very small pay, giving from 12 to 16 hours as a day's work. The profit to contractors employing this class of help was, of course, enormous. The immense amount of available labor, of this class, has been diverted to a new method of employment which is called the task system, and

to which the term "sweating" system was aptly applied. The sweating system, if conducted in workshops located in buildings devoted exclusively to manufacturing purposes, would never have obtained its present prominence in the public mind; but the competition between the employers of labor under this system resulted in a complete revision of conditions; cheaper shops were secured; large quantities of work per day were imposed upon the employed, until finally the tenement of the contractor was made to answer the double purpose of home and shop. The crowded condition of these tenements, hardly sufficiently large for the accommodation of the family, was increased by the addition of the help to be employed. All traces of home privacy were obliterated, sanitary conditions became unmentionable, filth and disease abounded and the health of the public became endangered. When these conditions were made plain to the people, fear overcame them and appeals to the State legislature for the prevention of this system of manufacture were made. These appeals led to the enactment of laws tending to restrict the manufacture of clothing in tenement-houses. The first law enacted, like most which tend to elevate the conditions of those who are obliged to labor for their living, emanated from the legislature of Massachusetts. This law provided that any house, room or place, used as a dwelling and also used for the purpose of manufacturing, should, within the meaning of the law, be deemed a workshop. The law defines a workshop as meaning any premises, room or place wherein manual labor is exercised by way of trade, or for purposes of gain, but the exercise of such labor in a private house by the family, if a majority of the persons therein employed are members of such family, shall not constitute a workshop. The law also contained a provision which was intended to prevent the importation into the State of garments which had been made under unhealthy conditions and this was enforced until similar laws were enacted in other States, particularly in the State of New York, from which the majority of this class of clothing was produced. The law also provides that any family desiring to do the work of making, repairing or finishing any coats, vests, trousers or wearing apparel of any description, in any room or apartment, in any tenement or dwelling house, shall first procure a license, approved by the chief of the inspection department. Every room or apartment in which any garments are made shall be subject to the inspection and examination of the inspectors, for the purpose of ascertaining whether the rooms or apartments are clean and free from any contagious nature. If the inspector finds evidence of infectious disease present he shall report to the local board of health.

The laws of many States require that no building which is designed to be used above the second story as a factory, or workshop, or mercantile or other establishment and has accommodations for 10 or more above the second story, and no building more than two stories in height, shall be erected until a copy of the plans thereof has been deposited with the inspectors. Such buildings shall not be erected without sufficient egress or other means of escape from fire, properly located and constructed. Such inspector may require that proper appliances

shall be provided in the floors, walls and partitions of such buildings to prevent the spread of fire.

**FACTORY ACTS.** See CHILD-LABOR; LABOR LEGISLATION.

**FACTORY CONSTRUCTION.** See BUILDING LAWS.

**FACTORY MANAGEMENT.** There are two accepted uses of the word "factory," the meaning in any given case depending largely on the context, and the term "Factory management" similarly partakes of this usage. As commonly used the term "factory" is understood to mean a group of elements made up of land and buildings, capital and credit, equipment and men, comprising what is known as the modern factory or establishment for the conversion of raw materials into goods for sale. *Factory management* in this sense is, therefore, the organizing and directing of men and materials for the production of goods through the medium of the factory.

The broader use of the term, however, includes any group of non-self-directing employees under the control of their employer, and it is so used particularly in reference to the series of problems arising wherever conditions of grouped labor obtain—in the railroad gang, the army, the construction crew—conditions reaching their climax in what we are familiar with as the modern factory. We may, therefore, encounter factory conditions and factory problems in fighting forest fires, for instance, though in no sense would a group of fire fighters be termed a factory. But it is just this broader use of the term which must not be overlooked, for it implies considerations of peculiarly far-reaching importance to the factory manager of to-day. For under present day factory conditions we encounter a complexity of relations and problems undreamed of a few years ago, and in order that the aims, and the ends, and the methods of modern industrial or factory management may be the more readily appreciated, it is necessary first to consider some of the fundamental problems which must be faced by those engaged in industry to-day. The massing of workers, the specialization of processes and the minute subdivision of labor, the economic dependence of the employee on the employer, the aggregation of capital and plant, and the keen competition in a world market—all conditions brought on directly by the industrial revolution and its succeeding developments—and finally with the more general dissemination of education among the workers themselves the growing insistence that labor have an increased participation in the operation and fruits of industry—the problems presented through these factors are all distinctly modern problems requiring distinctly modern methods of attack and solution. Some of the broader aspects of each of these factors will be briefly discussed.

**The Massing of Workers.**—The very act of bringing together a large number of employees brings with it entirely new problems. With a group of half a dozen workers we encounter certain problems; multiply this number by hundreds or even thousands, and our problems immeasurably increase not only in degree but also in kind. With any aggregation of persons for any purpose we encounter the psy-

chology of the crowd—the something within us which arises when we become one of a throng and which may, upon provocation, develop into the spirit of the mob. In the case of industry, however, to these psychological considerations must be added a third: the non-self-directing character of the groups of workers, imposing as this does the oftentimes tremendous burden of the mere physical handling and direction of our force. Taken together, these factors underlie many of the extremely delicate and far-reaching problems of organization and of management which the factory manager of to-day must face. What are to be the relations of the group as a whole to each individual, to each superior and to the firm as an individual? What form of organization, how administered, will best serve the true interests of each of these bodies—employer and employed? The simple organization of the small one-man business will no longer suffice. How, in the more complex organization, can there be maintained the desirable personal contact, freedom of action and play of individual initiative, together with the submission to authority necessary wherever men are grouped together for profitable production? These and scores of similar questions of organization and of management present themselves for solution the moment we bring together large numbers of individuals for any industrial purpose.

**The Specialization of Processes.**—It is sometimes said that the minute subdivision of labor resulting from advanced specialization of processes is all wrong, and that we should return more nearly to handicraft work. To what extent is this claim well founded, and how, if at all, do the interests of the individual and of society at large and in the long run conflict in any solution which may be evolved? On the one hand, through the expertness which results with specialization of labor, and through the increased use of machinery, goods are more cheaply produced. Sooner or later the selling price must thereupon be lowered, resulting in turn in an increased demand for the product. This increased demand must be supplied by additional labor, which reacts beneficially on the worker either through more constant employment at the same wages or through the same amount of employment at higher wages. Society at large of course also benefits. On the other hand, in certain industries and for comparatively short periods of time the individual workers, upon the sudden introduction of labor-saving machinery, have suffered through being thrown out of employment and through being unable to secure new work or work to which they could adapt themselves. Here society at large and in the long run benefits at the expense of the individual. It may at least be fairly said that there are elements both of strength and of weakness in the modern factory system of production, and if so, how are we to preserve the strong points and at the same time eliminate the dangers of this method? Is it, or is it not, a fact that there is and of necessity must be monotony in industry? That there is in many cases seems indisputable, but how about the necessity of it—are not ways being found, and may there not be other ways found to alleviate and in cases to eliminate monotony, secure the advantages of high specialization of labor, and

at the same time retain free scope for individuality and personal initiative? Such measures as the interchange of work and workers, the establishment of definite and proper tasks of short duration and the payment of a bonus for accomplishment of each, allowing and expecting on the part of each operative a more detailed knowledge of each step in the processes in which he is engaged, the various industrial partnership and profit sharing plans, the suggestion box and welfare work—such measures and many others may play their part here. These considerations, together with the very recently widespread extension of fatigue studies, form a comparatively open field in the realm of industry.

**The Economic Dependence of the Employee.**—Grave social problems arise through the economic dependence of the employee on his employer. Previous to the industrial revolution the apprentice or journeyman who had saved up a few dollars or who, in absence of these, had attached to himself a few regular customers, could withdraw from his employer and set up in business for himself. With the introduction of machinery and its accompanying demands, however, all this was changed; he could then no longer work for himself at his option because he lacked the necessary capital or the knowledge of the proper handling of capital, or the knowledge of all technical processes involved, with which to start his business, and he must perforce join the masses of hired workers dependent on the capitalistic entrepreneur. This change brought with it actual or implied obligations on the part of the employer, with corresponding obligations on the part of the employee. Foremost among the former was the social obligation of paying at least a living wage—unfortunately not always translated into action. Regularity of employment was another obligation. Proper working hours comprised an obligation notoriously overlooked until recently. The obligation of the worker as well as of the employer in regard to the determination of a proper day's work and a proper day's pay is constantly claiming the attention of the industrial world. Then how far beyond the providing of the bare necessities of life does the employer's duty extend? The attempt to answer this question plunges us at once almost hopelessly into the realms of reasonable costs and justifiable profits, of relative abilities and commensurate rewards, of standards of living and opportunities for advancement. The paying of at least a living wage, however, the maintenance of proper working conditions, accident insurance and the prevention of accidents and the provision for open channels for advancement—all these and many other duties which the employee can little effect, devolve as social obligations upon the management rather than upon the men, due simply to the relative economic positions of the two. It is correspondingly incumbent upon the employee to give his employer honest and whole-hearted co-operation and similarly to refrain from using unjustly to the detriment of the management any power he may possess or obtain through collective action.

**The Aggregation of Capital and Plant.**—So much for some of the broader aspects of some modern industrial problems viewed par-

ticularly from the standpoint of the employee. No less vital questions arise in the case of the employer. The very increase in size of plant and consequently in amount of capital involved, bring forth organization and managerial problems and policies only distinctly related to any questions of human relations. The mere act of keeping the wheels in motion smoothly requires organization and system to a degree unknown previous to the development of modern methods of production. Add to this the keen, worldwide competition, involving as this does the necessity of operating at a high efficiency in order to be able to survive in industry at all, and it must necessarily follow that these complex modern requirements of production must be met by complex modern methods of management. Where shall my plant be erected and how shall it be laid out; what is the minimum amount of equipment and labor necessary; how shall my business be organized and administered; what system of controlling each of the innumerable plant activities shall I use? Am I producing more cheaply than my competitors but losing money on the whole because my methods of buying or selling are archaic? What means of increasing production or decreasing costs with a given amount of labor and equipment may I take, and what are the interacting effects of these methods upon the larger questions suggested; how shall I deal with my employees, both individually and collectively, in order to attain the industrial ends of economical production, sale at a profit and growth to the point of diminishing returns with maximum prosperity for employer and employed? From among the scores of different ways in which each of these problems may be answered, how, for my particular case, am I to know and to utilize the one best way? It is upon this phase of the broader industrial problems—the technique of production and distribution—that a large part of the more recent literature on the so-called "efficiency movement" has been written. It is significant that Frederick W. Taylor, the pioneer and father of scientific management, never allowed simple efficiency in production to become with him an end in itself, but insisted both in his work and in his writings on adherence to the fundamental principles embodying the economic welfare of all persons concerned.

**Democracy in Industry.**—And finally, what is to be my attitude, be I manager or workman, in regard to democracy in industry and the distribution of the profits and losses arising through my participation? The maxim of a well-known railway magnate who, several years ago, gave expression to the sentiment "The public be damned" has been found to be no less an inadmissible working formula in industry than in railroading, perhaps much to the chagrin of several "captains of industry" who were wont to substitute "workman" in place of "public." Granted that we believe that a degree of democracy in industry is to be desired, there yet remains the delicate problem of balance as between the ideal and the exact degree which our particular concern, under our particular conditions at any given time, can justifiably affect. Many a concern has faced the bankruptcy court through a maladjustment, either one way or the other, of this balance. Such questions, together with those of the

division of profits, require for their proper solution the best informed and broadest minded men of the age, but most of all they require the close and active co-operation of both parties—capital and labor. Such are some of the questions presented to the modern factory manager. They are all more or less interrelated and no one of them can be properly viewed except in connection with the others. Collectively, all these questions form a background necessary to the adequate solution of any one of them. Each one, furthermore, is a life study and in the present discussion it is manifestly out of the question to attempt to cover the ground in any but a very broad survey. And in what follows in regard to the technique of factory management, a proper perspective must be maintained by keeping constantly in mind the broad social questions which must form the true background for a proper solution of these more tangible factors which arise for consideration in the every-day work of the executive.

Going back to our original definition we see that factory management as ordinarily considered deals, broadly, with land and buildings, capital and credit, equipment and men—that it is the organizing and directing of these elements in an establishment adapted to attain the ends of economical production, sale at a profit, and growth at least to the point where the effect of diminishing returns counterbalances the possible advantages of further expansion. The art of organizing and directing these elements of production, selling and finance, with all that this implies, constitutes the field of modern factory management.

Organization at once becomes the keystone upon which must be reared the whole structure which is to mold, guide and direct the activities of the business. Organization as such must be distinguished from the personnel which, at any given time, is entrusted with the task of making effective the policies and principles under which we are to operate. Although personality enters into and distinctly affects the minutiae of organization, organization must, to be permanently effective, be independent of the personality of any one man or group of men. The form of organization under which we are to operate must be determined only after a careful analysis of first: the problems which we encounter; second: the conditions under which we must solve these problems; and to a less extent third: the character of the personnel available; and as the conditions vary, so must the solution (organization) vary. A study of the evolution of organization not only reveals most interesting ramifications, but also may furnish invaluable instruction to one entrusted with the delicate task of molding the form of organization best adapted to any given enterprise. The subject may profitably be viewed from two standpoints: organization in war, and organization in industry. If we go back to primitive times we find comparatively small herds of savages making war upon the neighboring tribes. The conditions under which they operated were simple: small numbers of warriors, individual bodily encounter with primitive weapons only, a comparatively small territory covered on foot or on horse and hence an absence of the problems of engineering and transportation, maintenance largely individual by pillage, little or no division of labor, few ad-

ministrative or technical details, few problems of correlation, complete mobility. The problems were those of secrecy, surprise, control—swift, absolute control in everything. The solution was correspondingly simple: one-man control by the best, often the physically strongest, warrior. As is true generally in warfare, delay in execution becomes often more fatal than mistakes in details due to unbalanced judgment. We thus get a pure "line" form of organization—orders and directions being passed down directly from the leader to his warriors, each of whom performed all functions pertaining to the work. Up until the extensive use of gunpowder in warfare the problems and the conditions under which they had to be solved differed comparatively little from those theretofore encountered. We find the solution to minor changes to consist of minor extensions and developments of the previous form of organization—a delegation of supervisory powers to lieutenants immediately over the men, reporting directly to the one superior, who is thus somewhat relieved of the minute details of execution. With the development of modern warfare of course all this was changed. It was then no longer mentally or physically possible for the one strong man to maintain the personal touch and exercise the close supervision of all details of the operations, although it was still necessary for him to keep final control and authority absolutely to himself. This in turn made necessary an augmented means of solution, and as a result we find the development of the staff—a cardinal principle of military organization to-day. Here we have a group of expert officers under the chief of staff, reporting to the officer in command upon the innumerable specialized and technical questions encountered in modern warfare, the commander thereafter taking such action upon their recommendations as he sees fit and passing his orders down through the now numerous officers of the line until they finally reach the man in the ranks.

In industry on the other hand, previous to the industrial revolution (if we except such works as the building of the pyramids and of the cathedrals and similar construction projects) we find no grouped labor. Passing through the successive stages of industrial development as described by Bucher, of housework, wage work, handicraft and commission work, and up until the development of the factory system, we find production carried on entirely by individuals or small groups of home-workers. The problems of control—as expressed in organization—therefore were extremely simple and in many cases non-existent, seldom necessitating more than a one-man organization and perhaps entirely naturally the organization of the army served as the model and was literally copied by those engaged in industry.

With the rise of the factory system of production, however, conditions were revolutionized. Then arose the intricate questions of human relations and material management outlined in the opening paragraphs. The problems encountered were far different from those of warfare, not the least significant of which was the substitution in industry of duty and the good of the individual, for the idea of force and the good of the state which forms the background of military discipline and control.

It is, however, perhaps not strange that the traditional forms of organization of the army should have still been embodied wholesale in the activities of industry, where they remained firmly entrenched until comparatively recently. It was not until near the last of the past century that these fundamental differences as between military and industrial aims and methods became consciously recognized and embodied in the various forms of industrial organization which are offered to-day as more nearly applicable to industrial needs. In closing the discussion of organization, bare mention may be made of these modern tendencies and further details must be sought in the numerous writings on the subject. One of the earlier forms was the committee system. This exists in two forms—the committee with power to enforce its decisions and the committee with advisory duties only. In the latter case the organization retains most of the disadvantages of the staff, with few compensating advantages. Both forms are found to a limited extent in industry to-day. The departmental and the divisional forms differ somewhat in operation, but are little more than the extension of the principle of division of labor. None of these forms of organization necessarily differs in principle or operation from the regular line form of the military. A fundamental departure from the military, however, is found in the modern functional organization devised by Mr. Taylor in connection with the development of scientific management. Here the staff idea is utilized, but with this fundamental difference: in the staff the individual expert performs an advisory function only, while in the Taylor functional these same experts are given administrative authority to embody the results of their knowledge in orders issued direct to men under them as regards their particular sphere of action. Under conditions where this form of organization is necessary and applicable, surprising results are secured.

So much for the various forms of organization from which the factory manager must choose that best adapted to his particular circumstances. Of the other broad division of factory management as an art—the directing, the management of personnel and material—little need be said. Sufficient outline of the various factors to be considered has been suggested to give an insight into the nature of the problems involved. The problems of finance, of division of duties, of delegation of authority and responsibility, of purchasing, of storage of materials, of planning, of shop administration, of cost, of central control of all of these and the innumerable other necessary activities of the modern factory—all such questions arise in never-ending variety in the management of the plant—problems nowise different intrinsically from those of organization previously discussed, and problems requiring for their proper solution the same careful analysis and the same adherence to fundamental principles of proved soundness and practicability. See FACTORY SYSTEM; LABOR LEGISLATION; SCIENTIFIC MANAGEMENT.

HENRY H. FARQUHAR,

*Consultant in Industrial Management and Instructor in the Harvard Business School.*

VOL. 10—45

### FACTORY SYSTEM, The. Definition.

—The word factory seems to have been first used in its modern sense about 1792. Previous to this time a factor had been an agent, and all compound derivatives of this word had carried with them the idea of agentship. But with the new system of industry introduced by the Industrial Revolution (q.v.) the term seems to have been used as an abbreviation of manufactory, and in the first factory act in England in 1802 was used interchangeably with mills to designate cotton manufacturing establishments. To-day the term factory covers any establishment, with its buildings and equipment, used for the manufacture of goods. The legal definition varies widely in different States, but is usually based upon the number of workers; thus an extreme definition of factory is "any place where two or more persons are engaged in working for hire or reward in any handicraft." As a description this is a poor definition, for it leaves out of account the essential characteristics of the system. Better is C. D. Wright's definition, "a factory is an establishment where several workmen are collected for the purpose of obtaining greater and cheaper conveniences for labor than they could procure individually at their houses; for producing results by their combined efforts which they could not accomplish separately; and for preventing the loss occasioned by carrying articles from place to place during the several processes necessary to complete their manufacture."

Not merely has the definition of the term broadened, but the scope of the factory system has widened also. Applied originally only to the textile industry, it has gradually been extended to other branches of manufacturing, until to-day it dominates the manufacture of agricultural implements, automobiles, boots and shoes, carriages and wagons, clothing, fire-arms, metallic goods of all sorts, musical instruments, rubber goods, slaughtering and meat packing, wooden goods, watches, etc. Most of the people employed in the mechanical industries of this country to-day are working under the factory system. Indeed the principles which govern the factory system in the concentration and division of labor, the use of non-human power and of labor-saving machinery, have also been applied to other fields of economic activity such as agriculture, fishing, forestry, mining, transportation, and even personal and professional service. There can be no doubt therefore as to the importance of so universal a system.

**Domestic System.**—We shall perhaps better understand the factory system if we contrast it with the system under which industry was organized, at least in England, just before its introduction. This was the domestic system. According to this manufacturing—which was then truly "making by hand" (*manus-facere*)—was carried on by small masters in their own houses, with the help perhaps of a journeyman and an apprentice or two. Such a master almost always owned the implements or tools of manufacture. In some cases the raw material was the property of a middleman who simply hired the domestic worker to work it up into finished goods, while he distributed the raw material to the homes of the workers and collected the completed product. The essential

feature of the system, however, to which it owed its name, was the fact that manufacturing was carried on in his own house by the domestic worker, who usually also owned a plot of ground which he cultivated as a by-industry.

**Factory System.**—All this was entirely changed by the introduction of the factory system. The first series of changes that may be noted was the transfer of the industry from the home to the factory, the change in ownership of the implements of production from the artisan to the capitalist employer, and the change in the power that drove the machines from the muscles of the workers to the force of falling water, and later of expanding steam. A second characteristic of the factory system was the enlargement of the business unit. The textile industry was affected less than mining and the metallurgical industries; but transportation showed the greatest development along these lines. To-day, however, large-scale production is a common characteristic of almost all factory industries. As a result of these changes capital has become increasingly important in modern industry until our present system of industrial organization is often called a "capitalistic" system rather than a factory system.

**Evils.**—It is obvious that no such far-reaching change in industrial organization could be effected without serious disorganization and readjustment. The transitional period during which the factory system was instituted witnesses many serious evils, some of which have not yet been altogether eradicated, and which are consequently assumed by some writers to be inherent in the system itself. To a brief consideration of these we may turn. Five criticisms were noted by C. D. Wright in an account of the system given in the Tenth Census, as follows:\*

(a) The factory system necessitates the employment of women and children to an injurious extent, and consequently its tendency is to destroy family ties and domestic habits and ultimately the home.

(b) Factory employments are injurious to health.

(c) The factory system is productive of intemperance, unthrift and poverty.

(d) It feeds prostitution and swells the criminal lists.

(e) It tends to intellectual degeneracy.

In answer to these criticisms it may be pointed out that the employment of women and especially of children has been regulated and greatly reduced by factory legislation. The employment of married women and of young children is, however, still unhappily too great. On the score of health the best equipped and managed factories undoubtedly compare very favorably with the environment under which work was carried on in the home under the domestic system, but the number of dangerous and injurious trades has multiplied. The resulting evils should, however, be cared for by legislation. The next two counts may be dismissed as untrue; the factory system as such cannot be held responsible for these evils and in fact works directly against such a vice as

intemperance as inconsistent with efficiency. On the last point so eminent an authority as Prof. Alfred Marshall is of the opinion that the modern factory system makes higher demands upon the intellectual capacity of the workers than any system of industrial organization which has preceded it.

**Advantages.**—On the other hand certain positive advantages of the factory system of industry may be noted. It makes possible a vastly greater output. That this is not more equitably distributed is indeed a serious problem of social justice, but the inequity of our present system of distribution should not be made an indictment against the system of production which gives us more to divide. It has, moreover, greatly lessened the cost of production and hence lowered the price of thousands of articles, which have thus been brought within reach of everyone. One has only to point for illustration to the myriads of articles produced under the factory system which can be found in the 5 and 10 cent stores. And finally wages, both nominal and real, have increased under this system, so that the economic position of the average factory operative is better than that of a similar worker under the domestic system. All in all, in spite of certain dark spots, the factory system may be regarded as a long step forward in the march of industrial progress. See HISTORY, MODERN.

**Bibliography.**—Babbage, Charles, 'The Economy of Manufactures' (London 1835); Clarke, Allen, 'The Effects of the Factory System' (London 1894); Cooke-Taylor, R. W., 'Introduction to a History of the Factory System' (London 1886); Cooke-Taylor, R. W., 'The Modern Factory System' (London 1891); Hobson, J. A., 'The Evolution of Modern Capitalism' (New York 1894); Ure, Andrew, 'The Philosophy of Manufactures' (London 1861); Wright, C. D., 'Report on the Factory System of the United States' (Tenth Census, Volume Manufactures, Washington 1884).

ERNEST L. BOGART,

*Professor of Economics, University of Illinois.*

**FACULÆ**, the brighter spots sometimes observed on the sun's disc. Generally they are small at first and gradually assume large proportions. See SUN.

**FACULTIES, Court of**, an English ecclesiastical court, under the archbishop, which creates rights to pews, monuments and particular places and modes of burial, and has also various powers in granting licenses of different descriptions, as a license to marry, a faculty to erect an organ in a parish church or to remove bodies previously buried.

**FACULTY**, in ecclesiastical law, a privilege or license granted to any person by favor, and not as a right to do any act which by law he may not do. In the Roman Catholic Church, permission granted by an ecclesiastical superior to a duly qualified subject to hear confessions. Such permission only extends to the district over which the superior has jurisdiction. Thus, faculties are granted by bishops to the priests in their dioceses, and by the heads of religious houses to such of their subjects as they judge qualified to hear the confessions of the community. In the United States, the term faculty indicates the body of persons who are entrusted with the government and instruction of a uni-

\*C. D. Wright, 'Report on the Factory System of the United States,' in Tenth Census, Vol. II, p. 552.



versity or college as a whole, comprising the president, professors and tutors. It is also used for the body of masters and professors of each of the several departments of instruction in a university; as, the law faculty, etc.

**FACULTY OF ADVOCATES**, an incorporated society of Scottish jurists, with a membership of about 400. Practice in the higher courts of the kingdom is confined to members of the Faculty, who for admission are obliged to pass a special examination. Justices are appointed from the membership.

**FADEYEV**, fā-dā'yéf, Rostislav Andreievitch, Russian military writer: b. 1824; d. Odessa, 12 Jan. 1884. He made more than one campaign in the Caucasus, achieving a reputation as a scientific soldier that commands respect for his 'Sixty Years of War in the Caucasus' (1860); 'Russian Military Power' (1868); 'My Opinions of the Oriental Problem' (1870); 'Letters on Russia's Present Position' (1881); and many similar writings.

**FADIENSKOI**, or **THADDEUS ISLAND**, a Russian island of the Arctic Ocean, in the province of Yakutsk. It is 100 miles long by about 40 broad. The climate is very cold the greater part of the year, but the island is inhabited.

**FÆCES**, the residue of food, combined with the intestinal secretions, as it passes from the body. After chyme has passed into the large intestine it is then termed fæces. During health fæces consist largely of the undigested portions of the food taken into the body. They contain microscopically many epithelial cells from different parts of the intestinal canal; shreds of mucus, bits of meat-fibre, the character of which depends upon the ingested food, and which can be determined by the microscope; vegetable detritus consisting largely of parenchymatous and vascular tissues, plant-hairs, etc.; fat-globules; bacteria of many kinds; bile pigments; and other organic residues. As the chemistry of the fæces will vary widely according to the diet, charts of chemical composition are worthless. The consistency of the fæces also widely varies. Normally, fæces should be semi-solid; if too hard, constipation is probable; if too soft and watery, indigestion may be present, or some degree of colitis (q.v.). Large quantities of mucus indicate a colitis. The color of the fæces is of much importance in determining whether the normal functions of the intestine are being carried on. In health the fæces should vary from a light to an amber brown, white to yellow fæces indicating lack of bile-excretion or loss of fat-digestion. Very black fæces often result from excessive bile-elimination, but such are more likely to be present when the drinking-water contains small amounts of mineral constituents, notably iron. Many drugs modify the color of the fæces. In children, green to greenish stools indicate either the presence of certain pigment-forming bacteria, or they mean that there is excessive fermentation or putrefaction of the intestinal contents, leading to excess of oxidation of the bile-pigments. In either case castor oil is an excellent corrective. Tarry fæces, resembling coffee-grounds in color, usually indicate the presence of blood high up in the intestinal canal. If bleeding occurs in the large intestine or rectum, red is the prevailing tinge. Small quanti-

ties of blood color the fæces orange, like paprika. Cocoa and huckleberries cause a coloration of the fæces that may be mistaken for blood. Colorless or gray-colored stools usually indicate some form of biliary obstruction; or, perhaps from fatty indigestion, an excess of fat passed either from lack of bile-emulsion action or from loss of fat-absorption. Children taking cod-liver oil often have light-colored stools. These should be carefully studied to determine if digestion of the oil is taking place. Disturbance of the functions of the pancreas may also cause light-colored or fatty stools. The study of the color of the stools is of immense practical importance in medicine, and careful observation of this matter by the patient may be of immense service to the physician. In birds, fishes and reptiles, and in some mammals, urine is mixed with the fæces before they leave the body. See **INTESTINES**.

**FAED**, fād, John, Scottish artist: b. Burley Mill, Kirkcudbrightshire, 1820; d. Gatehouse-of-Fleet, Scotland, 22 Oct. 1902. In 1841 he went to Edinburgh to study, soon won a considerable reputation as a portrait and subject painter, and was elected a member of the Royal Scottish Academy in 1852. In 1851 he exhibited a work entitled 'The Cruel Sisters,' and this was followed by 'The Cotter's Saturday Night' (1854); 'The Philosopher' (1855); 'The Household Gods in Danger' (1856); 'Job and his Friends' (1858); and 'Boaz and Ruth' (1860). Going to London in 1862, he began to exhibit in the Royal Academy also, some of his pictures shown since that date being 'Catherine Seyton' (1864); 'Old Age' (1867); 'John Anderson, my Jo' (1869); 'After the Victory' (1873); 'The Morning before Flodden' (1874); 'Blenheim' (1875); 'In Memoriam' (1876); 'The Old Basket-Maker' (1878); and 'The Poet's Dream' (1883). His work invariably displays careful drawing, but his coloring is somewhat hard.

**FAED**, Thomas, Scottish artist: b. Burley Mill, Kirkcudbrightshire, 8 June 1826; d. London, 17 Aug. 1900. He was a brother of John Faed (q.v.), and at an early age became known as a clever painter of rustic subjects. The subjects of his brush are for the most part domestic or pathetic, which he depicted with a tender idealism that appealed strongly to the public taste. He was elected a member of the Royal Academy in 1864. Among his principal works are 'Sir Walter Scott and his Friends' (1849); 'The Mitherless Bairn' (1855); 'The First Break in the Family' (1857); 'His Only Pair' (1860); 'From Dawn to Sunset' (1861); 'The Last o' the Clan' (1865); 'Pot Luck' (1866); 'Worn Out' (1868); 'Homeless' (1869); 'The Highland Mother' (1870); 'Winter' (1872); 'Violets and Primroses' (1874); 'She Never Told her Love' (1876); 'Maggie and her Friends' (1878); and 'Rest by the Stile' (in the Metropolitan Museum, New York).

**FAENZA**, fā-en'zā (ancient **FAVENTIA**), Italy, episcopal city, in the province of Ravenna, on the river Lamone, 19 miles from the city of Ravenna. The cathedral of San Costanzo, begun in the 14th century, contains the exquisite early Renaissance tomb of Saint Savinus. It is noted for its glazed earthenware, called Faience (q.v.), the manufacture of which was famous from the 15th century and has been recently

revived. Others of its manufactures are majolica, silk goods and refined sulphur. In the neighborhood are ferruginous and saline springs of considerable repute. Faenza is connected with the Adriatic by the Zanelli Canal, opened in 1782. It claims to be the birthplace of Torricelli. Its history extends into the times before the Christian era, and many changes in government took place before 1509, when it was annexed by Julius II to the states of the Church. In 1860 it became a part of the kingdom of Italy. Pop. of the commune 40,164.

**FAERIE** (fā'ēr-ē) **QUEENE**, *The*. An epic poem by Edmund Spenser, published in 1590 (Books I-III) and in 1596 (Books IV-VI); a fragment of another book, consisting of two cantos on "Mutability," was published in 1609. The poem was planned in 12 books, each book containing 12 cantos; Spenser completed little more than half his design. His purpose, as set forth in his letter to Raleigh, was "to fashion a gentleman or noble person in virtuous and gentle discipline,"—thus like Castiglione's 'The Courtier' and other influential books of the time, the 'Faerie Queene' was designed to be a guide to conduct for men who were entering the service of the state. Conforming to current critical doctrine, instruction in the cardinal virtues characteristic of the illustrious prince is to be gained best through the study of poetry, not history or moral philosophy. (Besides the letter to Raleigh, consult also Sidney's 'Defense of Poetry'). Accordingly, epic poetry was held to be an allegory of the perfect hero: Homer so portrays "the good governor" in his Agamemnon and "the virtuous man" in his Ulysses; Virgil combines the two in his Æneas, while Tasso's Rinaldo is the ideal "private man" and his Godfrey the ideal ruler. Based on this theory, the 'Faerie Queene' was to deal with the "twelve private moral virtues, as Aristotle hath devised," in the person of Arthur before he became king; Spenser hints that he may treat Arthur as king in a second epic.

The plan was to be worked out by devoting each book to the exploits of a knight distinguished for a cardinal virtue. Saint George, the Red Cross Knight (Book I), represents Holiness; Guyon (Book II) represents Temperance in the classical sense of self-restraint; Britomart (III), a female knight, stands for Chastity; Cambell and Triamond (IV) for Friendship; Artegall (V) for Justice; and Calidore (VI) for Courtesy. Prince Arthur, who stands for Magnificence or Magnanimity, appears in several books; first, in his quest for Gloriana, the Faerie Queene, and second, as an assistant to the hero of the book in a crisis. This does not indicate incoherence of design, as some critics maintain, but follows the familiar construction of the Arthurian romances, where Gawain or Lancelot or Perceval, or whoever happens to be "the greatest knight in the world," is introduced at a crisis in the fortune of the hero whose adventures are being narrated.

Spenser's use of the Arthurian romances is interesting and original. None of the great knights familiar in Malory and elsewhere appears; none of the great stories afterward used by Tennyson finds a place. The Holy Grail, for example, is barely mentioned. Yet

the basis of the plot is familiar to any reader of the metrical romances of France and England. The Faerie Queene holds a feast lasting 12 days, on each of which an "adventure" takes place. On the first day a "clownish young man," who reminds us of Perceval or of Gareth, begs the boon of any "adventure" that may befall; he is sent with Una to free her parents from the thralldom of a dragon. On the second day a Palmer bearing a babe with bloody hands calls for a champion to slay Acrasia, the enchantress who wrought the woe, and Sir Guyon is assigned the task. On the third day Scudamore is sent to free Amoret from an enchanter, but his adventure is completed by Britomart. But all this explanatory matter is set forth in the letter to Raleigh; Spenser follows Virgil and other poets in beginning "in the midst," and the epic did not arrive at the point where the setting could be given in verse. Moreover, Spenser follows the late mediæval romances in giving to familiar romance situations allegorical or mystical significance. Thus, Galahad's delivery of the Castle of Maidens, which in the Grail cycle had come to symbolize Christ delivering mankind from the Seven Deadly Sins, is used by Spenser. The quest, also, appears in many forms. For example, the quest of Red Cross for the dragon reaches a climax in a three days' battle in which the monster stands for Satan, who has long held the human race (Castle Mortal) in bondage; the three days' battle symbolizes Christ's victory over Death and Hell so often met in mediæval legend. Spenser's poem is filled with such reminiscences of the Arthurian romances; their influence on him is far more pervasive than the debt, largely exaggerated, to Ariosto and Tasso, from whom he derives, as from the classics, many matters of detail.

Spenser uses the technique of romance for a more carefully elaborated moral allegory than had been developed in the mediæval cycles. Thus, Book I shows how Holiness (Red Cross), accompanied by Truth (Una), slays the dragon of Error. Again the adventures of Guyon (Book II) symbolize the course of temperance through life, avoiding extremes of gloom or of false joy, avoiding wrath and excessive passion, conquering desires for wealth or sensual enjoyment. The allegory of the poem is complex: there is the type found in mediæval moral plays, representing the conflict of vices and virtues; there is the mystical interpretation of Christian doctrine; there is also translation of Plato's idealism into allegorical story. To blend with a conception so complex as this the Renaissance ideal of the perfect courtier (Spenser has in mind a man of affairs like Sidney, not a mediæval ascetic saint) rendered it impossible for the poet to use Malory's version of the Arthurian legend in any complete or definite way. Yet the chief clue to his method is to be found, not in his moral and religious allegory, which has been too much stressed in Spenser criticism, but in his purpose to shadow forth his conception of the greatness of Elizabethan England and of its destiny. To bring this out, he represents, in Prince Arthur, the English realm; Gloriana, the Faerie Queene, is Elizabeth Tudor. Fundamentally the poem means that the return of the old Welsh (Fairy) line, represented in the Tudors, to the government

of England is the source of England's present greatness. He distinguishes carefully between fairy knights like Guyon and English knights like Saint George (Red Cross). The Queen of the Fairies appears to Prince Arthur in a vision of a type familiar in Celtic folklore, and promises in due time to give herself to him; England, personified in Arthur, seeks to realize this vision, made complete when Elizabeth rules. Thus the poem glorifies the ancestry of the reigning house according to the rules of Renaissance epic.

But there is yet more. Artegal, knight of Justice, loves Britomart, the martial spirit of England. Justice united with British might points out a new destiny. Artegal's quest is to free Irena (Ireland) from Grantorto (Philip of Spain). In this book also Prince Arthur rescues Belgæ (the Netherlands) from the Spanish monster, and Duessa (Mary of Scotland) is adjudged worthy of death. Thus certain crucial events in Elizabeth's reign are set forth: the conflict with Spain necessitated the crushing of the Irish rebellion, fomented by Philip; it necessitated also the aid sent to the Netherlands, crushed by Philip's vast cruelty, and the execution of Mary, the chief means through which Philip plotted the destruction of free England. In a later book, Spenser no doubt would have included the final triumph over the Armada. Furthermore, this exposition has a direct bearing on the foreign policy of Elizabeth and is a defense of that school of politics that held it to be England's duty to emerge from isolation, to take part in continental politics, to substitute for diplomatic intrigue positive action on behalf of the oppressed in the Low Countries and in France against the sinister shadow of Philip's ambition for world power. The poem is not merely a moral allegory of abstract virtues, not merely a glorification of the Queen, but a positive and almost defiant defense of a greater nationalism that led eventually to the establishment of British sea power and the imperial domain. Raleigh, "the Shepherd of the Ocean," is recognized by Spenser as a leader in this progressive movement, as he also recognized Leicester and Essex and opposed the more conservative policy of Lord Burghley.

Besides these allegories of moral and political ideas, which appealed to Elizabethan love of symbolism and shadowed forth the romantic idealism of the time, are many lovely features that deepen the picture. Such are Calidore's wooing of the shepherdess Pastorella, as charming as the pastoral scenes in Shakespeare's 'Winter's Tale'; or the flight of Britomart with her nurse to Merlin's cave, there to learn of Artegal; or the stories of Florimel and of Amoret. These stories, and many other strands in the complex web of Spenser's weaving, are of the very essence of romance—the light that never was on sea or land that Wordsworth meditated upon, or the faery lands forlorn recalled to momentary life in the poetry of Keats. In this is one secret of Spenser's influence upon later English poetry, an influence more pervasive than Chaucer's or Milton's or even Shakespeare's. It is not that he is a master of narrative: one who desires merely a story had best go elsewhere. It is not that he recreates the world of chivalry as Malory or Chrétien had seen it in earlier times. He

draws upon all sources; ancient and mediæval, romance and allegory; his learning is enormous; one stanza may be compounded of samples from many fields. But it is all fused, through the magic of his imagination, into a new unity that we feel rather than see. His sources are a thousand romances, but he is romance incarnate.

Partly this is due to his wonderful stanza. The foundation of it is not *ottava rima*, as is often said, but an eight-line stanza adapted by Chaucer from the French and having the same rhymes: ababbcbc. To this Spenser added an alexandrine that repeats the third rhyme. Singularly adapted to the genius of one who has been called "the painter of the poets," Spenser gets from it an astonishing variety of effects through his mastery of alliteration, vowel stress, repetition, and epithet. The music of bird song and running water is in it, the opulence of taste and touch ("He seems to feel with his eyes")—the pictures in language that the poets of the Renaissance sought to paint. These pictures are not alone of the kind often associated with his poem,—an enchantress in a Bower of Bliss, or some vividly wrought epic simile. Colin's fairy hill, a stream of living water at its base, guarded by fairies from every noisome thing; a little open place outside the stream, and beyond, as a frame for the picture, woods of matchless height that seemed to disdain the earth, is one example of his painting; another is the scene of the hundred furnaces in the Underworld, surrounded by swarms of dwarfs engaged in stirring the molten ore with great ladles, with the sudden apparition of the Fairy Knight, "glistening in armes and battailous array."

Though Spenser's genius is not primarily dramatic, this element in his work is not wanting. He often refers to the theatres and to acting, and among his lost works we read of nine comedies. The masques of the "Faerie Queene"—the Temple of Venus, the Masque of Cupid, the Gardens of Adonis, the Seven Deadly Sins, the Masque of the Seasons, and others—form a constant element in his work. The journey of Guyon through the Underworld is both masque and drama, as is also the overthrow of the enchanter Busirane by Britomart. In comparison with these, the masques introduced by Shakespeare into his plays are pale and ineffectual. The tragi-comedy of Malbecco is excellent throughout, and reminds one, in its power of characterization and its edged humor, of Jonson or Massinger. Spenser's characters are not all pale abstractions, creatures of boundless virtue or ugly vice. Britomart has the spirit, the bravery, as well as the beauty of Beatrice, and like Beatrice she is adorably feminine. Una is as lovely and appealing as Hermione; Pastorella is another Perdita. Guyon's career is no succession of tilts with abstractions; the conflict is as real as in many an Elizabethan tragedy, with victory for his reward.

But these are mere details, their only service being to recall once more the infinite variety of the elements composing the poem. The abiding impression which it leaves upon the mind is that of a succession of marvelous dissolving views, a panorama in which the antique and mediæval worlds are blended with the epic-like life that England then was living. This

life Spenser views through Merlin's magic glass, to which time and space are immaterial, and all human experience is but the semblance of things not seen.

EDWIN GREENLAW,  
*Kenan Professor of English in the University of North Carolina.*

**FAEROE ISLANDS.** See FAROE ISLANDS.

**FAESULÆ.** See FIESOLE, Italy.

**FAFNIR**, fäf'nēr, in the mythology of the Nibelungenlied, a son of the magician Hreidmar. In the form of a dragon he guarded the gold which was paid in atonement for the death of Otr, and was slain by Siegfried.

**FAGAN, James Bernard**, Irish dramatist: b. 18 May 1873. He was educated at Clongowes Wood College and Trinity College, Oxford. Intended at first for the church, the bar or the Indian Civil Service, he abandoned in turn all three and went on the stage. He was with F. R. Benson for two years, 1895-97, and with Sir Herbert Beerbohm Tree in 1897-99, retiring in the latter year. He produced 'The Rebels' (1899); 'The Prayer of the Sword' (1904); 'Hawthorne, U. S. A.' (1905); 'Under which King' (1905); 'A Merry Devil' (1909); 'The Earth' (1909); 'False Gods,' a translation (1910); 'The Dressingroom' (1910); 'Bella Donna,' an adaptation (1911).

**FAGEL**, fä'hël, **Frans Nicolaas**, Dutch soldier: b. Nimwegen 1645; d. Sluys 23 Feb. 1718. He was a nephew of Gaspar Fagel (q.v.), entered the military service in 1672. He distinguished himself in the battle of Fleurus 1690, and the famous defense of Mons, 1691, was directed by him. He also displayed great military talent at the siege of Namur, at the capture of Bonn and in Portugal 1703, in Flanders 1711 and 1712, at the battles of Ramillies (1706) and Malplaquet (1709).

**FAGEL, Hendrik, BARON**, Dutch statesman: b. 1765; d. 1834. He received his education at the University of Leyden and in 1787 became second secretary to the States-General; afterward he became secretary. With Van de Spiegel he was commissioned in 1794 to make a treaty of alliance with England and Prussia. When the princes of Orange became exiles Fagel accompanied them. In 1813 he was named Ambassador to England and remained in that post until 1824. With Lord Castlereagh he signed the London Convention, under the terms of which many of her colonies were restored to Holland. In 1829 Fagel was appointed minister without portfolio.

**FAGEL, Kaspar or Gaspar**, Dutch statesman: b. The Hague 1629; d. 1688. He was made pensionary of Haarlem in 1663 and seven years later became secretary to the States-General. He succeeded De Witt as grand pensionary. He allied himself with William of Orange and took a large part in having the latter declared hereditary stadtholder. To him also is due no small part of the credit for the accession of William to the throne of England after the Revolution of 1688. Fagel's incorruptibility and patriotism was demonstrated by his refusal of a bribe of 2,000,000 francs from Louis XIV.

**FAGERLIN**, fä'gér-lën, **Ferdinand Julius**: b. Stockholm, 5 Feb. 1825. In 1854 he began

his art studies and entered the Academy of Stockholm; thence he passed to Düsseldorf and finally became a pupil of Couture at Paris. From Düsseldorf he started on a professional journey northward for the purpose of studying sea and coast life in Holland. The pictures he then painted are true to nature, subtle in characterization and abound in wholesome humor.

**FAGGING**, in the schools of intermediate or secondary education in England, a term designating the services which boys of the lower forms are by custom obliged to render to the boys of the upper forms. Usually a lower-form boy is assigned to an upper-form boy, whose "fag" he is then said to be. For his master he performs various services, but never menial. Consult Hughes, 'Tom Brown's School Days.'

**FAGIN**, fä'gin, a despicable Jew in Dickens' 'Oliver Twist.' He is represented as training up children in crime in order to profit by their thievish practices and condemned to be hanged for receiving stolen goods.

**FAGIUS, Paul** (German, Büchlein), German reformer and Hebraist: b. Rheinzabern, in the Palatine, 1504; d. Cambridge, England, 1549. He studied at Heidelberg and Strassburg; at the latter place giving special attention to Hebrew under the direction of Wolfgang Capeto. He was made pastor at Isny in 1537 and here he continued his Hebrew studies under Elias Levita. He set up a printing press from which he issued several Hebrew works. In 1542 he became professor of Hebrew at Strassburg and later held similar chairs at Constance and Marburg. In 1546 he went to Heidelberg, where he joined the Reform Party. He was deposed in 1549, and in the same year was invited by Cranmer to England. He died soon after his arrival. Queen Mary in 1557 caused his body to be exhumed and burned. Fagius left several commentaries on books of the Old Testament. His 'Hebrew Grammar' (1543) was important in its day.

**FAGNANI**, fän-yä'në, **Joseph**, Italian painter: b. Naples, Italy, 1819; d. 1873. He studied at Vienna and Paris, and came to the United States with Sir Henry Bulwer in 1849; here he painted 'The Nine Muses' (portraits of New York women), now in the Metropolitan Museum. He also painted many European celebrities.

**FAGNIEZ**, fa'nyä', **Gustave Charles**, French historian: b. Paris 1842. He received his education at the Ecole des Chartes and the Ecole des Hautes-Etudes and secured a post in the department of national archives. Subsequently he was member of the commission of diplomatic archives under the direction of the Minister of Foreign Affairs. He was one of the founders of the Historical Society of France and became a member of the editorial staff of the *Revue Historique*. He has published several works dealing mainly with economic history. These include 'Etudes sur l'industrie et la classe industrielle à Paris au XIIIe et au XIVe siècle' (1877); 'La mission du père Joseph à Ratisbonne' (1885); 'Le père Joseph et Richelieu' (1894); 'L'Economie sociale de la France sous Henri IV' (1897); 'Documents relatifs à l'histoire de l'industrie et du commerce' (2 vols., 1898-1900); 'Le duc

de Broglie' (1902); 'Corporations et syndicats' (1905).

**FAGOT**, a bundle of sticks or small branches of trees bound together. In times of religious persecution the fagot was a badge worn on the sleeve of the upper garment of such persons as had abjured heresy, being put on after the person had publicly carried a fagot to some appointed place, by way of penance. Among military men in England, fagots were persons hired by officers whose companies were not full, to muster and hide the deficiencies of the company, and thus cheat the government.

**FAGOT-VOTE**, in Great Britain, was a vote manufactured for party purposes by the transfer to persons not otherwise legally qualified of sufficient property to qualify them as electors. Estates were divided up into what was called 40-shilling freeholds, to each of which a bogus proprietorship (with a vote) might attach; but under the Franchise Act of 1884 this qualification was abolished and fagot-votes can no longer be manufactured.

**FAGOT-WORM**, a caterpillar of a moth of the genus *Eumeta*, which in Ceylon is common on the coffee-trees. It forms a pupa case of silk covered with small sticks, so that it looks like a bundle of fagots; and local folk-lore explains that these worms are the abode of the souls of persons who in their lifetime were thieves of firewood. These moths are related to the bag-worm moths (q.v.).

**FAGOTTO**, fa-got'tō, a brass wind instrument, blown with a reed, which can be taken in pieces and carried like a bundle of fagots, hence the name; a bassoon (q.v.).

**FAGUET**, fa-gā, Emile, French literateur and academician: b. La Roche sur Yon Vendée, 17 Dec. 1847; d. Paris, 7 June 1916. He was educated at the Lycée Charlemagne, Paris, and was graduated from l'Ecole Normale in 1867. He taught for some time at La Rochelle and Bordeaux. Later he came to Paris, where he became professor of poetry in the university in 1890, and was elected to the Academy in 1900. His works include 'La tragédie au XVIIe Siècle' (1883); 'Le Théâtre contemporain' (1880-91), comprising his dramatic criticisms; 'Dix-huitième siècle' (1890); 'Seizième siècle' (1893); 'Drame ancien, drame moderne' (1898); 'Histoire de la littérature française' (1900); 'La politique comparée de Montesquieu Rousseau, et Voltaire' (1902); 'Propos Littéraires' (1902); 'La Pacifisme' (1908); 'Les Préjugés nécessaires' (1911); 'Monseigneur Dupanloup, un grand évêque' (1914). He rehabilitated especially the literature of the 17th century, and took an active interest in the criticism of the modern drama, of politics and even of philosophy.

**FAGUS**, the typical genus of the Beech family (*Fagaceæ*). The genus has five species, natives of the northern hemisphere, only one of which, the common beech (*F. Americana*), is native to the United States. All the species are trees with smooth gray bark and serrate leaves, the flowers and leaves appearing together. The name is from the Greek, to eat, referring to the edible nuts. See BEECH.

**FAHAKA**, an edible globe-fish (*Tetraodon fahaka*), singular in inhabiting the fresh waters of the Nile.

**FA HIEN**, fā hē-ën', Chinese monk and explorer: he was born in Wu-Yang, province of Shan-si, in the 4th century, A.D. In the 15 years from 399 to 414 he traveled in India, Khotan and Tibet in the company of other Chinese pilgrims to the great Buddhist festivals. He penetrated Kashmir, Kabul, Kandahar, the Punjab and central India. In all he spent 10 years in India in quest of information about Buddhism and its founder. He also sought complete texts of the 'Vinaya-pitaka.' He went to Ceylon and there copied other sacred texts. From Ceylon he journeyed to Java, whence he re-entered his native country. His 'Fo-kue-ki,' written after his return, is a full account of his wanderings in the Buddhist countries. This work appeared in a French translation (Paris 1836) and in English by Beal (2d ed., London 1884), Giles (Shanghai 1877), and Legge (Oxford 1886). Consult Beazley, 'Dawn of Modern Geography' (3 vols., Oxford 1904-06); Giles, 'History of Chinese Literature' (New York 1901).

**FAHLCRANTZ**, fal'kränts, Christian Erik, Swedish divine and poet: b. Stora Tuna, Falun, 1790; d. 1866. From 1839 to 1852, in conjunction with Almquist and Knös he issued the *Ecclesiastical Journal*. He wrote several polemical works and also several long poems. He was appointed bishop of Westerås in 1849. His greatest work is the humorous satire 'Noach's Ark' (1826). Consult 'C. E. Fahlcrantz: Samlade Skrifter' (7 vols., Oerebro 1866).

**FAHLCRANZ**, fäl'kränts, Karl Johann, Swedish landscape-painter: b. Dalecarlia, 29 Nov. 1774; d. Stockholm, 1 Jan. 1861. Studying nature diligently, he became a self-educated artist. He was acquainted only with northern scenery, but has given it with great fidelity and spirit. His principal productions are in the possession of the King of Sweden.

**FÄHLMANN**, fäl'man, Friedrich Robert, Russian philologist: b. Esthonia, 1800; d. 1850. At the University of Dorpat he studied medicine and philology and in 1842 was appointed lecturer on the Esthonian language at that seat of learning. He collected a vast amount of material which he edited. His biographer, Kreutzwald, published it under the title 'Kaleviade' or 'Kalevipoeg' (1857-61).

**FAHNE**, fa'nē, Anton, German historian: b. Münster, 1805; d. 1883. At Bonn and Berlin universities he studied medicine, law and theology. He is remembered for his histories of episcopal sees, cities and noble houses of Westphalia and the Rhine District. They include 'Forschungen aus dem Gebiet der rheinischen und westfälischen Geschichte' (5 vols., 1864-75); 'Denkmale und Ahnentafeln in Rheinland und Westfalen' (6 vols., 1883); 'Lioland; Ein Beitrag zur Kirchen-und Sittengeschichte' (1875).

**FAHRENHEIT**, fā'ren-hīt, Gabriel Daniel, German physicist: b. Dantzic, 14 May 1686; d. Amsterdam, 16 Sept. 1736. He settled in Holland, where in 1720 he first conceived the idea of using quicksilver instead of alcohol in thermometers—a discovery by which the accuracy of the instrument was very much improved. He took, as the limit of the greatest cold, that which he had observed at Dantzic in the winter of 1709. The space between the point to which the quicksilver fell at this tem-

perature, and that to which it rose in boiling water, he divided into 212 parts. About 1724 he discovered the fluctuation of the boiling point of water, which he had made one of the fixed points of his thermometer. Fahrenheit's thermometer owed its beginnings to the invention of a thermometer by Newton, described in the 'Philosophical Transactions' for 1701. Newton's instrument was a tube filled with linseed oil, and the starting-point of the scale was the temperature of the human body, which Newton called 12. Newton divided the space between his datum and the freezing-point of water into 12 equal parts, and stated that the boiling-point of water would be about 30 of these degrees on the scale. Fahrenheit, when he began to work with Newton's thermometer, did not find the scale minute enough for his purposes. He therefore first doubled the number of degrees, making the scale number 24 instead of 12. Finding he could, by mixing ice and salt, obtain a temperature below freezing, Fahrenheit next adopted this for his starting-point and counted 24° up to body heat, making the freezing-point 8 and calling boiling water 53. Later on he again divided his degrees into four. It will be seen that if the above figures are multiplied by four, the result is the thermometric scale called after him which is still in use. He was elected to the Royal Society of London in 1724, and contributed five papers on physics to the 'Transactions' for that year.

**FAIDHERBE**, Louis Léon César, loo-è lä-ôn sä-zär fä-därb, French general and author: b. Lille, 3 June 1818; d. Paris, 29 Sept. 1889. Entering the army in 1840, he became lieutenant in 1842. From 1854 till 1861, and again from 1863 till 1865, he was governor of Senegal, in which capacity he considerably extended the French possessions there. After the fall of Napoleon III, he was summoned by the government of National Defense to France and appointed commander of the army of the north, and at Baupaume and Saint Quentin displayed military ability of a high order. In the latter part of his life he went on a mission to Egypt to study the monuments and hieroglyphics. He was called to the Senate in 1879, and was Chancellor of the Legion of Honor. He wrote valuable monographs on Senegal, the Sudan and other parts of Africa, including 'L'Avenir du Sahara et du Sudan' (1863); 'Collection complète des inscriptions Numidiques' (1870); 'Nouvelles inscriptions Numidiques' (1872); 'Langues Sénégalaises' (1887); and 'Le Sénégal: la France dans l'Afrique Occidentale' (1889). On the Franco-German War he published 'Campagne de l'Armée du Nord en 1870-71' (1872).

**FAIENCE**, fä'äns', spelled also formerly *fayence* and *fayance*. Originally this term was given to designate the opaque tin-enamelled ware made in France which came into being by imitating, first at Nevers (1600), the Italian majolica. (See MAJOLICA). A long mooted point is whether the term is derived from the Italian town Faenza or from Faïence, in France. The term was later used to express any tin-enamelled ware, such as Delft (see DELFT FAIENCE) and those made in imitation elsewhere. It has at last become the term for any art pottery, hence takes in majolica, Persian lustre pieces, Hispano-Moresque, and even the

lightly glazed "Henri Deux" (see SAINT PORCHAIRE) ware, Wedgwood (see WEDGWOOD), Palissy (see PALISSY); and the modern felspathic art-decorated "stone china," etc., have been termed *faïence fine*, or *faïence anglaise*. Among connoisseurs the word *faïence* is still, generally, considered to define a soft, porous bodied earthenware covered with opaque tin-enamel and decorated in colors. This takes in the following factories:

Of 16th century fabriques in France the earliest was Nevers (the Conrades), to be followed by Rouen (see ROUEN), Palissy ware; Lyons, Beauvais, Rennes. Outside France, Hirschvogel was working in Nuremberg; Talavera (Spain) and Delft (see DELFT FAIENCE) were active centres of *faïence*. In the 17th and 18th centuries the following factories (among others) were added: Paris (Claude Révérend), Saint Cloud (the Chicaneaus), Bordeaux, Clermont-Ferrand, Sceaux-Penthièvre (Chapelle), Sinceny, Strassburg and Hagenau (the Hannongs), Moustiers (see MOUSTIERS), Marseilles (the Clerissys, Savy, Viry, etc.), Niderviller (Lemire), Lunéville (Cyfflé), Sarreguimines, Aprey (Ollivier), Lille (Boussemaert), Saint Denis, Apt, La Rochelle, Valenciennes, Bourg-la-Reine, Varages, Rubelles, Orléans, Saint Amand-les-Eaux, Desvres, Aire, Saint Omer, Chantilly, Creil, Saint Paul, etc. French ceramists of note for decorative wares in modern times are Deck, Boulenger, Guidan, Optat Millet, Ulysse de Blois, Parvillée, Haviland, etc.

**Faïence Fine**.—When Astbury or Heath (undecided which), in England, discovered (1720) the use of ground flint (silica) to give a white slip coating to the colored local clays, they were enabled to make a ware similar in appearance to Delft; but the slip did not fuse and a glaze had to be added. The noted "cream-colored" body (see POTTERY) soon developed and revolutionized pottery making the world over. "China clay" and "china stone" (felspar clays) added to the flint produced a perfectly white hard body, and the English had the *faïence fine* or *faïence anglaise* that put an end to making coated or enamelled wares. It is the "standard" body used universally to this day.

**Bibliography**.—Azam, Dr., 'Les anciennes Faïenceries de Bordeaux' (Bordeaux 1880); Aussant, M. J., 'Fabrique de poteries artistiques à Fontenay, près de Rennes, au XVI et XVII siècles' (Rennes 1900); Barber, E. A., 'Tin enamelled Pottery, Majolica, Delft and other stanniferous Faïence' (Philadelphia 1906); Barbier, V., 'Poterie de la Savoie' (Chambery 1875); Burton, W., 'A History and Description of the Old French Faïence' (New York preface 1903); Cavalucci and Moler, E., 'Les Della Robbia' (Paris 1884); Cohendry, M., 'Céramique Arverne' (Clermont-Ferrand); Dangibeaud, C., 'Notices sur les potiers et les faïenciers de la Saintonge' (Saintes 1884); Davillier, J. C., 'Histoires des Faïences de . . . Marseilles et autres fabriques méridionales' (Paris 1863); Despierres, G., 'Histoire de la Faïence de Saint-Denis-sur-Sarthon' (Alençon 1889); du Monceau, Duhamel, 'L'Art du potier de terre' (in 'La Grande Encyclopédie,' Paris 1773); Fiéffé, 'La Faïence patronomique . . . dans la



From Strassburg

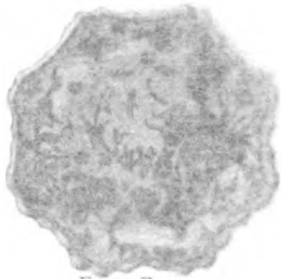
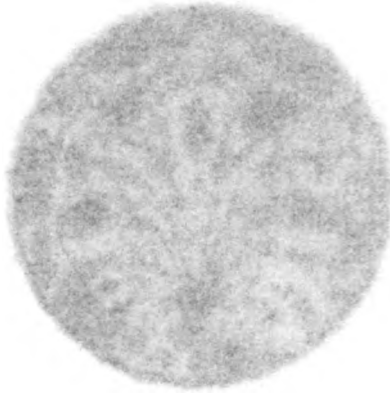

From Rouen

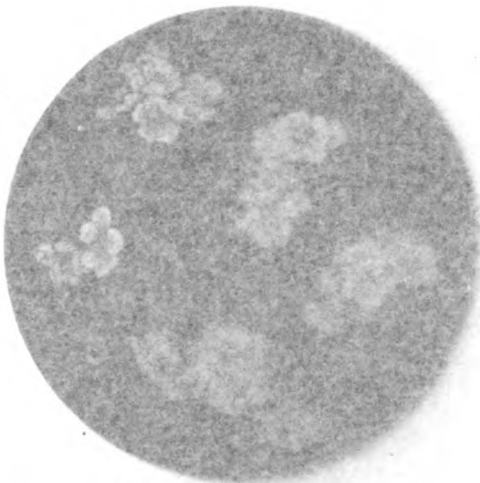
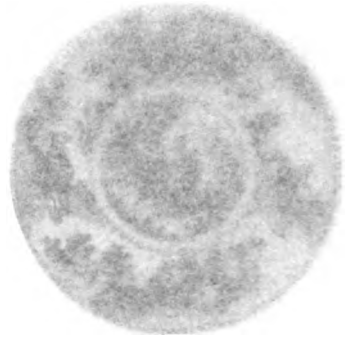

Modern English Pattern

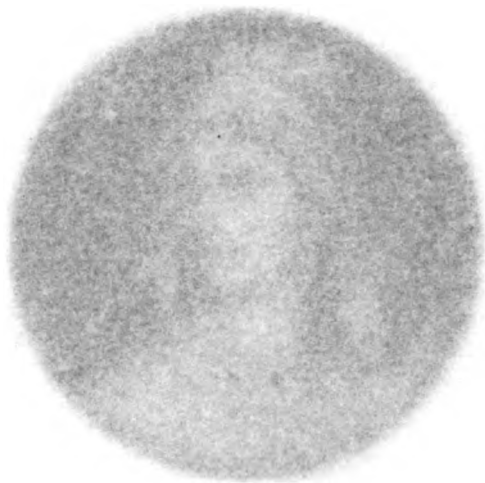





**FAIENCE**



**From Strassburg**



**Persian Faience**



**Old German Jug**



**From Rouen**



**Hirschvogel Pitcher**



**Delft Ware**



**Modern English Faience**



**Modern French Faience**

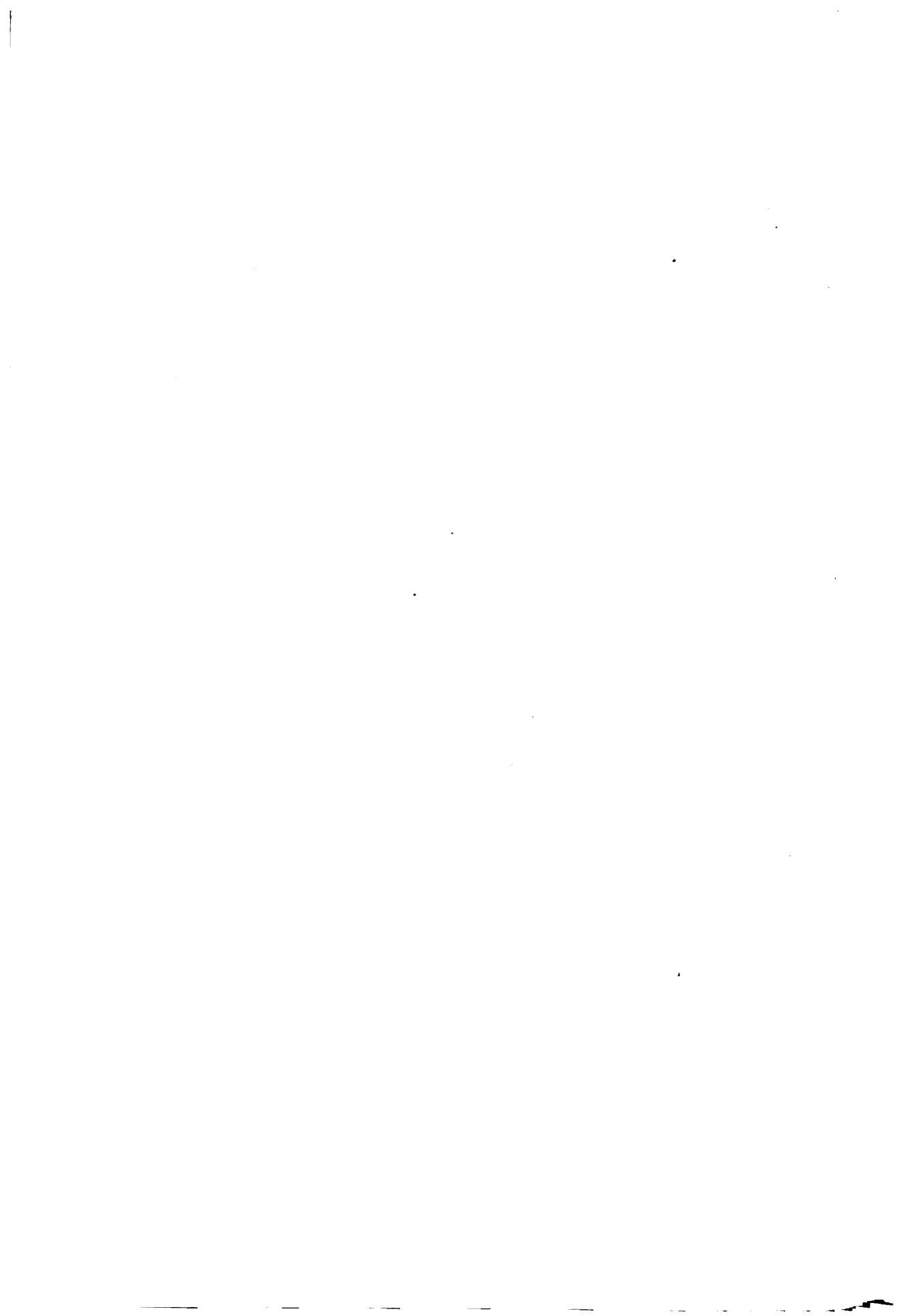

Céramique nivernaise' (Clamecy 1901); Fil-  
lon, B., 'L'Art de Terre chez les Poitevins'  
(Niort 1864); Foville, J. de, 'Les Della Rob-  
bia' (Paris 1910); Forestie, E., 'Les anciennes  
faïenceries de Montauban, Arduis, Negrepelisse,  
Auvillar, etc.' (Montauban 1876); Fraisse, du,  
de Vernines, 'Parallèle des Oeuvrages de Po-  
terie d'Auvergne, anciens et modernes' (Paris  
1874); Frantz, H., 'French Pottery and Porce-  
lain' (London 1906); Gasnault, P., and Gar-  
nier, E., 'French Pottery' (London 1884);  
Gerspach, 'Documents sur les anciennes  
faïenceries françaises' (Paris 1891); Grange,  
G., 'Histoire de la manufacture de faïence de  
Clermont-Ferrand' (Clermont-Ferrand 1882);  
Grasset, 'Historique de la Faïencerie de La  
Charité-sur-Loire' (Paris 1876); Houdry, J.,  
'Histoire de la céramique lilloise' (Paris  
1869); Joly, A., 'Paul-Louis Cyfflé' (Nancy  
1864); Lambert, G., 'Traité pratique de la  
fabrication des faïences fines' (Paris 1865);  
L'Aulnoit, H. de, 'Essai de la Faïence de  
Douai, dites Grès Anglais' (Lille 1882); Leader-  
Scott, 'Della Robbia and other Sculptors'  
(London 1883); Lejéal, A., 'Recherches his-  
toriques sur les manufactures de faïence et de  
porcelain de Valenciennes' (Valenciennes  
1868); Le Men, R. F., 'La manufacture de  
faïence de Quimper' (Quimper 1875); Loche,  
Comte de, 'Notice sur la fabrique de faïence  
de la Forest' (Chambery 1880); Mareschal,  
A. A., 'La faïence populaire du XVIII siècle'  
(Paris 1872); Michel, E., 'Essai sur l'histoire  
des faïences de Lyon' (Lyons 1876); Musset,  
G., 'Les faïences rochelaises' (La Rochelle  
1888); Pier, G. C., 'Pottery of the Near East'  
(New York 1909); Solon, L. M. E., 'A His-  
tory and Description of Old French Faïence'  
(London 1903); Tainturier, A., 'Recherches  
sur les anciennes manufactures de porcelain  
et de faïence d'Alsace et de Lorraine' (Strass-  
burg 1868); Thoré, 'Les anciennes fabriques  
de faïence et de porcelaine . . . de Sceaux'  
(Paris 1868); Vaillant, V. J., 'Les céramistes  
boulonnais' (Boulogne 1899); Wallis, H.,  
'Persian Lustre Vases' (London 1899); War-  
mont, 'Recherches historiques sur les faïences  
de Sinceny, Rouy et Oignes' (Paris 1864).

CLEMENT W. COUMBE.

**FAILLON, Michel Etienne**, mē-shel ā-tē-en  
fā-yōn, French historical writer: b. Tarascon,  
France, 1799; d. Paris, 25 Oct. 1870. He was a  
Sulpician and visited Canada in 1854 to investi-  
gate the houses of that order. He wrote lives  
of noted French-Canadian religionists such as  
Mme. d'Youville (1852); and Mlle. France  
(1854); a history of the Church in North  
America (1853), and a comprehensive history  
of the French in Canada, three volumes of  
which appeared (1865-66) before his death.  
His 'Life' was published at Paris in 1877.

**FAILLY, fa'yé', Pierre Louis Charles de**,  
French soldier: b. Rozoy-sur-Serre, 1810; d.  
1892. He received his military training at  
Saint-Cyr and after graduation joined the army  
in Algeria. At the outbreak of the Crimean  
War he was gazetted brigadier-general. He  
was a division commander in Italy in 1859 and  
took part in the battles of Magenta and Sol-  
ferino. In November 1867 he defeated Garibaldi  
at Mentana. At the beginning of the  
war with Prussia in 1870 the emperor appointed  
him commander of the Fifth Army Corps. At

Beaumont on 30 Aug. 1870 he commanded the  
right wing of McMahon's army, but was forced  
to retreat, leaving McMahon's right unpro-  
tected and resulting in his retreat being cut off.  
The direct result was the capitulation after  
Sedan, and an immediate consequence to Failly  
was his removal and Wimpffen's succession to  
his post. In 'Campagne de 1870: Opérations  
et marche du 5ème Corps jusqu'au 31 août'  
(1871) he defended his conduct of operations.

**FAILSWORTH**, England, town in Lan-  
cashire, four miles north by east of Manchester,  
on the Lancashire and Yorkshire Railway.  
Cotton manufacturing is the principal industry.  
The electric-lighting and tramway services are  
supplied from Manchester. Pop. 15,098.

**FAILURE**. See BANKRUPT.

**FAIN, fān', Agathon Jean François**,  
BARON, French historian: b. Paris 1778; d.  
1837. In 1806 he became secretary of the Im-  
perial archives, three years later was created  
baron and in 1813 became private secretary to  
Napoleon I. He served the Emperor faithfully  
until 1815 and drew up the papers of abdic-  
ation. In 1830 Fain was appointed first secre-  
tary of the Cabinet and served three years as  
deputy from Montargis in 1834-37. He pub-  
lished several memoirs, including 'Manuscrit de  
1814, contenant l'histoire des six derniers mois  
du règne de Napoléon' (1823; 4th ed., 1906);  
'Manuscrit de 1813' (2d ed., 1825); 'Manuscrit  
de 1812' (2 vols., 1827); 'Manuscrit de l'an  
III' (1828). His 'Mémoires' were published  
in 1908.

**FAINÉANTS, fā-nā-ān, or DO-NOTH-  
ING KINGS**, the name given in French history  
to some of the Merovingian sovereigns, who  
were the puppets of the mayors of the palace.  
The last of these kings was Childeric III.

**FAINT** (syncope), a peculiar form of sud-  
den loss of consciousness. Impoverishment of  
the blood, lowered vitality from any cause, an  
overwrought nervous system and disease of  
the circulatory system predispose to such at-  
tacks. The immediate cause is an anæmia of  
the brain. This sudden cerebral anæmia is most  
frequently due to shocking sights, sickening  
smells, pains or fears. The attack may be ush-  
ered in by a period of nausea, sighing respira-  
tion, or "faint feeling." Immediate lowering of  
the head below the rest of the body will fre-  
quently ward off further trouble. Most com-  
monly the attack is very sudden, the face be-  
coming absolutely bloodless and having a death-  
like calm; the pulse is weak or imperceptible,  
the breathing very shallow. In true syncope  
spasms are not present, neither is voiding of  
the urine or fæces. Fatal termination is rare,  
consciousness ordinarily being restored in a few  
moments if prompt measures are taken. The  
patient must be placed in a recumbent position,  
with the head as low or lower than the rest of  
the body; constricting clothing should be  
loosened; and water may be slapped on ex-  
posed parts. Smelling-salts held to the nose  
are of value. Later mild stimulants may be  
used to restore normal condition; but resump-  
tion of vertical position should be postponed as  
long as practicable.

**FAIOM, or FAYOUM**. See FAYUM.

**FAIR, James Graham**, American capitalist:  
b. near Belfast, Ireland, 3 Dec. 1831; d. San

Francisco, 28 Dec. 1894. He emigrated to America in 1843 and went to California in the famous '49 year. He amassed great wealth by mining in Nevada, to which he went in 1860. He served from 1881-85 as a Democratic representative from Nevada to the United States Senate.

**FAIR GOD**, Mexican traditional hero and culture god. See QUETZALCOATL; MEXICAN MYTHOLOGY; YUCATAN; UXMAL.

**FAIR GOD**, *The*, a romance by Lew Wallace 1873. It is a story of the conquest of Mexico by the Spaniards, its scene laid upon Aztec soil, in the early part of the 16th century. The title is derived from Quetzalcoatl, "the fair god," the Aztec deity of the air.

**FAIR HAVEN**, Mass., town in Bristol County on Buzzard's Bay, at the mouth of the Acushnet River and on the New York, New Haven and Hartford Railroad, 60 miles south of Boston and opposite New Bedford, with which it is connected by bridges. Here are the Millicent Public Library, the Academy of the Sacred Heart, several banks, churches and other public buildings. It has manufactories of glass, castings, nails, loom cranks, whale boats, oil casks and tacks. Many buildings of architectural merit, which render Fair Haven one of the most attractive towns of the State, were erected by Henry H. Rogers (q.v.) as memorials to members of his family. One architectural group, a fine example of Tudor architecture, consisting of a church and two other buildings, is considered a model of beauty. The town is a summer resort. The government is administered by town meetings. Fair Haven was separated from New Bedford and incorporated as a town in 1812. On 7 Sept. 1778, the militia, commanded by Maj. Israel Fearing, repulsed a British attack here. Pop. 5,122. Consult Ricketson, 'The History of New Bedford' (New Bedford 1858).

**FAIR HAVEN**, Vt., town of Rutland County, 30 miles east of Rutland, on the Delaware and Hudson Railroad. It has a Carnegie library and extensive slate manufactories. The town owns the waterworks and sewerage system. It received its charter in 1783, at which time it included West Haven. Pop. 3,095.

**FAIR HAVENS** (Gr. *Καλοὶ Λιμένες, Καλοὶ Λιμένες*), an anchorage on the southern coast of Crete, five miles east of Cape Litino. It is of small size and amply sheltered from western winds. The only mention of it by ancient writers is that by Paul (Acts xxvii, 8), whose well-known shipwreck occurred after departure from Fair Havens for Phenice or Phoenix. It is probable that there was no town at that point, although, as stated in Acts, Lasea was but a short distance away.

**FAIR HEAD**, or **BENMORE**, a precipitous promontory of the north coast of county Antrim, Ireland, opposite Rathlin Isle. It rises 636 feet above the sea and consists of carboniferous strata, overlaid by greenstone columns, 20 to 30 feet thick and 280 to 320 feet high.

**FAIR ISLE**, a solitary Shetland island lying midway between Shetland and Orkney, and 30 miles southwest of Lerwick. It is three miles long and two miles broad. The men employ themselves chiefly in fishing and the women

in knitting the well-known Shetland hosiery. They are said to have acquired this art from the Spanish seamen whose ship, belonging to the Armada, was wrecked here in 1588. Pop. 139.

**FAIR MAID**. See SCUP.

**FAIR MAID OF PERTH**, *The*, a novel by Sir Walter Scott, published in 1828. The heroine is Catherine Glover.

**FAIR OAKS AND DARBYTOWN ROAD**, *Engagement at* (SECOND BATTLE OF FAIR OAKS). On 27 Oct. 1864, General Grant began a movement on the Petersburg lines to seize the South-side Railroad, and as a support to the movement had ordered General Butler to make a demonstration north of James River on Richmond. Parts of three divisions of the Tenth Corps under General Terry, six brigades of the Eighteenth Corps under General Weitzel and General Kautz's cavalry division, were designated for the movement. Terry was to make a demonstration along the Darbytown Road, under cover of which Weitzel was to push through White Oak Swamp to reach the Williamsburg road and seriously threaten Richmond. The columns started from camp, near Chaffin's farm, very early on 27 October. Terry reached the Darbytown Road, a part of his command crossed over to the Charles City Road and advancing on both roads, a little before 8 A.M. engaged the Confederates in their entrenchments from the New Market Road to the Charles City Road. Weitzel, after a march of 16 miles, crossing both the Darbytown Road and Charles City Road, at 1 P.M. reached the Williamsburg Road at Heintzelman's old works, on the battlefield of 31 May 1862, and pushed at once down the road one and a half miles toward Richmond, and came upon the Confederate works which appeared to be feebly held by a small body of dismounted cavalry and three guns. Weitzel prepared to attack, first sending a brigade of colored troops across the York River Railroad to find and turn the Confederates' left near the New Bridge Road. The defenses north of the James were held by General Longstreet, with the divisions of Generals Hoke and Field, some "local defense" troops under General Ewell, and General Gary's cavalry brigade. These were posted with reference to defense along the river roads. As soon as Longstreet detected Weitzel's movement he ordered Field's division to move to the left and it formed on either side of the Williamsburg Road. It was 3.30 P.M. when Weitzel, with two brigades and others in support, advanced on either side of the road, over open ground, and was met with an unexpected heavy fire of musketry and artillery. His troops almost reached the works, but were repulsed with a severe loss in killed, wounded and missing. Soon after dark Weitzel withdrew after losing over 1,000 men. While Weitzel was engaged, Terry, at 4 P.M., was ordered to press his demonstration and carry the entrenchments. He made the attempt and was repulsed. On the next day the expedition returned to camp. The Union loss was 905 killed and wounded and 698 missing. The Confederate loss was comparatively small; Field's division and Gray's brigade reported 64 killed, wounded and missing. The entire loss probably did not exceed

100. Consult Humphrey, 'The Virginia Campaign of 1864-65.'

E. A. CARMAN.

**FAIR OAKS (SEVEN PINES), Battle of.** After the battle of Williamsburg (5 May 1862) the Army of the Potomac, under General McClellan, advanced cautiously up the Peninsula, established a base at White House and 20 May his advance crossed the Chickahominy at Bottom's Bridge, and the entire Fourth Corps under Gen. E. D. Keyes crossed on the 23d, taking position 25 May at Seven Pines, on the main road to Richmond, about five miles distant. The Third Corps, under Gen. S. P. Heintzelman, crossed 25 May. This left on the north bank the Second, Fifth and Sixth Corps, commanded respectively by Gens. E. V. Sumner, Fitz John Porter and Wm. B. Franklin. McClellan began to rebuild destroyed bridges and to perfect communication between the two wings of his army astride the Chickahominy. The movements of McClellan north of the Chickahominy and information from his cavalry convinced Gen. Joseph E. Johnston, the Confederate commander, that General McDowell with a strong corps was about to join McClellan from Fredericksburg, upon which, 28 May, he ordered up General Huger's division from Petersburg and Drewry's Bluff and suggested to General Lee that every available command should be concentrated at Richmond. On 25 May General Casey's division of the Fourth Corps advanced from Seven Pines to Fair Oaks, about three-fourths of a mile, and threw up works covering the road, and on 30 May two brigades of Kearny's division, Third Corps, were advanced about a fourth of a mile in front of Savage Station to within supporting distance of Casey. General Couch's division, Fourth Corps, was at Seven Pines and General Hooker's division, Third Corps, on the border of White Oak Swamp. Johnston, from his works, three miles in front of Richmond, watched McClellan's cautious advance. A reconnaissance 30 May developed the fact that Keyes had advanced his lines to Fair Oaks; Johnston saw his opportunity and issued orders for an attack next day. The Army of the Potomac, 31 May, had 127,166 officers and men, of whom 98,008 were present for duty, and it had 280 guns. Johnston had about 63,000 effectives and was not well supplied with artillery. Johnston purposed to throw 23 of his 27 brigades against Keyes and Heintzelman and with four brigades along the line of the river from New Bridge to Meadow Bridge prevent the rest of McClellan's army from crossing the stream. He purposed to move the 23 brigades by the Charles City, Williamsburg and Nine Mile roads, crush Keyes' corps and drive it back in disorder on Heintzelman and capture or destroy those two corps before any assistance could reach them from the north bank of the stream. There was some misunderstanding of orders on the morning of the 31st and much consequent delay, but at noon Gen. D. H. Hill's division of four brigades deployed in double line on either side of the Williamsburg Road, advanced on Casey's division at Fair Oaks and after a severe fight of two hours drove it back upon Couch's division at Seven Pines. Hill now received a reinforcement of one brigade, and two brigades of Kearny's division came to

the assistance of Couch and Keyes, and the struggle was renewed at Seven Pines, with the result that the entire Union force was driven back to a line of entrenchments about a mile in the rear, which position was held. Three Union divisions had been engaged and suffered severely, and a part of Couch's division had been cut off. Gen. G. W. Smith, with several Confederate brigades, was observing the Chickahominy, under orders to engage any troop that might cross the stream to assist Keyes and Heintzelman, or, if none came, he was to fall upon the right flanks of the Union lines engaged. After waiting some time and believing that no Union troops would cross to the south bank of the stream, Smith put some of his troops in motion to make the flank attack, but it miscarried from the timely arrival of Sumner on the south bank of the Chickahominy. Sumner, who was nearest Keyes and Heintzelman, heard the sound of battle at 1 o'clock and was at once in the saddle and ordered his troops under arms. A little later orders came from McClellan that he should be prepared to march at a moment's notice. Without waiting another moment he marched his two divisions to the Chickahominy and paused upon the two bridges, waiting orders to cross them. At 2.30 p.m. the order came to cross. Richardson could get but one brigade of his division over the lower bridge and was obliged to move up and follow Sedgwick's division over the Grapevine Bridge, which swayed and tossed in the river. But the solid column of Sedgwick's infantry, loading it with a weight with which even the angry Chickahominy could not trifle, soon pressed and held it down among the stumps of the trees, which in turn prevented its lateral motion. Once across, Sumner pressed forward on the road, deep with mud, toward Fair Oaks, and came up to Couch, who with four regiments and a battery had been cut from his division and was holding ground about a half mile from Fair Oaks, with Smith approaching to make his flank attack. But four of Sumner's regiments had formed on Couch when Smith attacked, two more soon followed, and these six regiments, with Couch's checked all efforts of Smith's four brigades to dislodge them and saved the day at Fair Oaks. Richardson's division came up at nightfall and formed on Sedgwick's left extending toward a brigade of Heintzelman's corps, while Hooker coming to the support of the defeated troops on the Williamsburg road filled vacant spaces in the line. There were now three corps across the Chickahominy in continuous order, ready for action when day should dawn. Near the close of the day General Johnston, the Confederate commander, was severely wounded and relinquished command to Gen. G. W. Smith. On the morning of 1 June, the Union army awaited attack, which was delivered by the Confederates, and on some parts of the line the fighting was severe, but the advantage remained with the Union troops, who regained most of the ground lost the previous day. On 1 June Gen. R. E. Lee was placed in command of the Army of Northern Virginia, but did not take direction of affairs on the field until the fighting was over, and 2 June withdrew to the fortifications around Richmond from which Johnston had advanced 31 May. The Union forces engaged at Fair Oaks numbered about 36,000;

the Confederates about 32,000. The Union loss was 4,384 killed and wounded and 647 missing; the Confederate loss was 5,729 killed and wounded and 405 missing. Consult Alexander, 'Military Memoirs of a Confederate' (1907); Allan, 'The Army of Northern Virginia in 1862'; 'Battles and Leaders of the Civil War' (Vol. II); McClellan, 'My Own Story'; Michie, 'Life of General McClellan'; 'Official Records' (Vol. XI); Walker, 'History of the Second Army Corps'; Webb, 'The Peninsula.'

E. A. CARMAN.

**FAIR ROSAMOND**, the common appellation of the daughter of Lord Clifford, who became mistress of Henry II. A popular legend says she was kept by the king in a bower at Woodstock, which was reached by a labyrinthine passage, known only to the king. The legend adds that in 1173 Queen Eleanor discovered and poisoned the fair Rosamond.

**FAIR SIDEA**, *The*, a play of Jakob Ayer, which by some is considered the source of Shakespeare's 'Tempest.'

**FAIR TRADE**, an expression used in Great Britain by those who, professing to be free traders and objecting to the free trade fiscal policy of that country as a one-sided business, would tax goods imported from any country which refuses to give reciprocal concessions to British exports. Free traders consider this view as protectionist. They hold that if they can import goods cheaper from a protectionist country than elsewhere, they should be free to reap that advantage even if they cannot export their own goods to that country free of duty. See **FREE-TRADE**.

**FAIRBAIRN**, Andrew Martin, English theologian: b. near Edinburgh, 4 Nov. 1838; d. 9 Feb. 1912. After ministering in charges of the Scottish Evangelical Union, he was appointed in 1877 to the principalship of Airedale Independent College, Bradford; and was the first principal of Mansfield (Congregational) College, Oxford, 1886-1909. His most important works are 'Studies in the Philosophy of Religion and History' (1876); 'Studies in the Life of Christ' (1881); 'The City of God' (1882); 'Religion in History and in Modern Life' (1884); 'Christ in the Centuries' (1892); 'The Place of Christ in Modern Theology' (1893); 'The Philosophy of the Christian Religion' (1902).

**FAIRBAIRN**, Patrick, Scotch Presbyterian clergyman: b. Hallyburton, Berwickshire, 28 Jan. 1805; d. Glasgow, 6 Aug. 1874. He received his education at the University of Edinburgh. In 1826 he was licensed to preach and served as pastor in the Orkney Islands, Bridgeton in Glasgow and Salton. In 1843 he became minister of the Free Church, remaining in Salton. He was professor of divinity in the Free College of Aberdeen 1853-56, and from 1856 until his death principal of the Free Church College of Glasgow. He was moderator of the General Assembly in 1865 and a member of the Free Church delegation which visited the United States in 1867. He translated several works from the German and edited 'The Imperial Bible Dictionary' (2 vols., 1866). He was the author of several volumes including 'The Typology of Scripture' (1845-47; new ed., New

York 1900); 'Ezekiel and the Book of His Prophecy' (1851); 'Prophecy viewed in its distinctive nature, its special functions and its proper interpretation' (1856); 'Hermeneutical Manual' (1858); 'Pastoral Theology,' with a biographical sketch of the author by J. Dodds (1875).

**FAIRBAIRN**, SIR William, Scottish engineer: b. Kelso, Scotland, 19 Feb. 1789; d. 18 Aug. 1874. His father was a farm servant. He entered business in Manchester, England, in 1817. He constructed the first iron ship in Great Britain, for traffic on the Forth and Clyde Canal, and afterward his firm built nearly 1,000 vessels. He was a friend of George Stephenson, made great improvements in cotton mill machinery, was the inventor of a rivetting machine which effected a revolution in the method of manufacturing boilers, and was associated with Robert Stephenson in designing and building the great tubular bridge over Menai Strait. He was created a baronet in 1869. He was the author of 'Mills and Millwork'; 'Iron, Its History and Manufacture'; 'Application of Iron to Building Purposes'; 'Iron Shipbuilding'; 'Useful Information for Engineers'; 'An Experimental Inquiry into the Strength, Elasticity, Ductility and other Properties of Steel,' etc. Consult his 'Life,' edited by Pole (London 1877).

**FAIRBANK**, Calvin, American clergyman: b. Pike, N. Y., 3 Nov. 1816; d. Angelica, N. Y., 12 Oct. 1898. He was an ardent abolitionist, and during 1837-39 aided 23 slaves to escape across the Ohio River. In 1843 he raised \$2,275 to secure the liberty of a nearly white slave girl who was to be sold at auction at Lexington, Ky. In 1844 he opened the way for the escape of the Hayden family, for which offense he suffered five years' imprisonment. Later he was again detected in violation of the Fugitive Slave Law, and sentenced to 15 years' imprisonment at Frankfort, where he was cruelly treated, receiving about 35,000 lashes on his naked body. In 1864 he was set at liberty after spending more than 17 years in jail. He published 'How the Way Was Prepared' (in which he told the story of his own life).

**FAIRBANKS**, Arthur, American teacher and author: b. Hanover, N. H., 1864. He was graduated at Dartmouth College in 1886, and received a doctorate from Freiburg, Germany. He has taught at Dartmouth, Yale and Cornell, and from 1900 to 1906 professor of Greek literature in the State University of Iowa. In 1907 he was elected director of the Boston Museum of Fine Arts. Among his writings is an 'Introduction to Sociology' (1901), which has been translated into Japanese; 'First Philosophers of Greece' (1898); 'A Study of the Greek Pæan' (1900); 'The Mythology of Greece and Rome' (1907); 'Handbook of Greek Religion' (1910); 'Athenian White Lekythoi' (Vol. I, 1907; Vol. II, 1914).

**FAIRBANKS**, Charles Warren, American lawyer and statesman: b. near Unionville Centre, Union County, Ohio, 11 May 1852; d. Indianapolis, Ind., 3 June 1918. His father was a Vermonter and was one of the early pioneers who settled in the West in the middle, 30's and helped to hew out of the wilderness the great Buckeye State. The son's earliest life was

spent in toil on the farm. He attended the public school in the neighborhood until his 15th year, when he entered the senior preparatory department of the Ohio Wesleyan University at Delaware, Ohio, where he was graduated in 1872. After leaving the university he went to Pittsburgh, Pa., as Associated Press agent, meanwhile studying law. He was later transferred to the Associated Press at Cleveland, Ohio, where he continued his legal studies in the Cleveland Law School, until he was admitted to the Supreme Court of Ohio in 1874, and in the same year removed to Indianapolis, Ind., where he began the practice of his profession. He took an active interest in politics but sought no public office until he was elected to the United States Senate in 1897. He was chairman of the Indiana State conventions in 1892, 1898 and 1914. In 1895 he had the unanimous complimentary vote of his party, which was in the minority, for the United States Senate. He was elected to the United States Senate 30 Jan. 1897, and at the expiration of his term was re-elected, but resigned 4 March 1905 to qualify as Vice-President of the United States, to which office he was elected on the ticket with Theodore Roosevelt in 1904. He was a delegate-at-large to the Republican National Convention at Saint Louis in 1896 and was temporary chairman of the convention; a delegate-at-large to the Republican National Convention at Philadelphia in 1900 and was chairman of the Committee on Resolutions; a delegate-at-large to the Republican National Convention at Chicago in 1904 and was chairman of the delegation; a delegate-at-large to the Republican National Convention at Chicago in 1912 and was chairman of the Committee on Resolutions. He was appointed by President McKinley a member of the United States and British Joint High Commission which met in Quebec in 1898 for the adjustment of the Alaskan, the Fur Seal and other questions growing out of our relations with Canada; he was chairman of the American commissioners. By appointment of President Roosevelt he represented the United States at the Tercentenary Celebration at Quebec in 1908. He was a candidate for the Republican nomination for President in 1908. At the close of his term as Vice-President in company with Mrs. Fairbanks he made a tour around the world. At the Republican National Convention at Chicago in June 1916 he was nominated for Vice-President of the United States on the ticket with Charles E. Hughes. He has received the degree of LL.D. from Baker University, Ohio State University, Ohio Wesleyan University and Northwestern University. He was a member of the board of trustees of the Ohio Wesleyan, DePauw and American universities and president of the Methodist Hospital of Indiana and the Indiana Forestry Association. He was a member of the Board of Regents of the Smithsonian Institution.

**FAIRBANKS, Henry**, American inventor: b. Saint Johnsbury, Vt., 6 May 1830. He is a son of Thaddeus Fairbanks (q.v.), and was graduated at Dartmouth College in 1853, and at Andover Theological Seminary in 1857. He was ordained in 1858; held pastorates in Burke and Barnet, Vt., and in 1859 was professor of physics, and later of history, at Dartmouth. He became identified with the manufacturing

firm of E. and T. Fairbanks and Co., in 1868; and subsequently gave much of his time to mechanical experiments, and patented a scale for weighing grain and subsequently perfected and patented 34 additional inventions of various kinds. He is president of Saint Johnsbury Academy and is prominent in the work of the Congregational Church in Vermont.

**FAIRBANKS, Thaddeus**, American inventor: b. Brimfield, Mass., 17 Jan. 1796; d. Saint Johnsbury, Vt., 12 April 1886. He settled in Saint Johnsbury in 1815, and there worked with his father in a saw and grist mill, and also in the manufacture of carriages. In 1824 he and his brother Erastus began the manufacture of stoves and plows. In June 1831 he patented the platform scales bearing his name. Afterward about 50 different improvements were made on these scales, which have been sold in all parts of the world; his last patent being taken out when he was 90 years old. His donations to Saint Johnsbury Academy totaled \$200,000.

**FAIRBANKS, Alaska**, city and capital of the fourth judicial district, on the Tanana River near the head of navigation, 160 miles west of Dawson, and 350 miles by stage north of Valdez. It is the commercial centre of the Fairbanks gold-mining region and is connected with Chena, 45 miles distant by the Tanana Valley Railroad. It is in all respects a modern city, with a centrally located steam-heating plant, schools, churches, electric light and power plants, etc. It is connected with Valdez by a stage route and in summer there is steamboat communication with Dawson to the east and to Saint Michael on the west. In the three years 1906-08, Fairbanks sent out \$27,000,000 in gold. Lode mining has in recent years displaced the earlier placers. The government of the United States has undertaken the construction of a railroad to Fairbanks at a cost of over \$14,000,000. Pop. 3,541.

**FAIRBURY, Ill.**, city of Livingston County, on the Wabash and the Toledo, Peoria and Western railroads, 60 miles east of Peoria. Coal mining and farming are the leading industries. The city has grain elevators, flour mills, cement works and machine shops. It has a public library. Pop. 2,505.

**FAIRBURY, Neb.**, city and county-seat of Jefferson County, on the Little Blue River, the Saint Joseph and other branches of the Chicago, Rock Island and Pacific System, about 60 miles southwest of Lincoln. It is situated in a good agricultural region, and its chief manufactures are flour and dairy products. A large nursery is just outside the city limits. The city contains a Carnegie library and fine post-office building. It owns its waterworks and electric-light plant. Pop. 5,294.

**FAIRCHILD, Ashbel Green**, American clergyman: b. Hanover, N. J., 1 May 1795; d. Smithfield, Pa., 1864. He wrote many contributions to the religious press. His most popular work, 'The Great Supper,' was translated into German and had an immense sale. He also published 'Baptism'; 'Faith and Works'; and 'Confession of Faith.'

**FAIRCHILD, Charles Stebbins**, American financier: b. Cazenovia, N. Y., 30 April 1842. He was graduated at Harvard University in

1863; admitted to the bar in 1865; became deputy attorney-general of New York in 1874 and attorney-general in 1876. After spending some time in Europe he settled in New York city in 1880, where he practised law till 1885. He was assistant Secretary of the Treasury 1885-87, and Secretary 1887-89. He was a member of the monetary commission appointed by the Indianapolis Monetary Conference in 1897. From 1879 to 1905 he was president of the New York Security and Trust Company and later he held high offices in other corporations.

**FAIRCHILD, David Grandison**, American botanist: b. East Lansing, Mich., 7 April 1869. He was graduated at the Kansas State Agricultural College in 1888 and made post-graduate studies in botany at Naples, Italy, in 1893, at the University of Breslau and Berlin in 1894, Münster and Bonn in 1895-96, and at Buitenzorg, Java, in 1896. Since 1889 he has been connected with the United States Department of Agriculture, since 1898 has been agricultural explorer and since 1903 has been in charge of foreign explorations. In 1897 he organized the work of seed and plant introduction of the Department, now the office of Seed and Plant Introduction, of which he has had charge since 1906. He has made special researches in botany since 1896 as assistant to Barbour Lathrop on four expeditions in search of economic plants for introduction into the United States. He is a member of the American Association for the Advancement of Science and of the International Society of Botanists.

**FAIRCHILD, George Thompson**, American educator: b. Brownhelm, Ohio, 6 Oct. 1838; d. 1901. He was graduated from Oberlin College 1862 and from Oberlin Theological School 1865; was professor of English literature, Michigan Agricultural College, 1879-97; and was vice-president of Berea College from 1898. He entered the Congregational ministry in 1871 and was the author of 'Rural Wealth and Welfare' (1900).

**FAIRCHILD, Herman Le Roy**, American educator: b. Montrose, Pa., 29 April 1850. He was graduated at Cornell University in 1874; was secretary of the New York Academy of Science in 1885-88; president of the Rochester Academy of Science 1889-1902; secretary of the Geological Society of America 1890-1907 and president in 1912. In 1911 he was president of the New York State Commission Government Association. He has been professor of geology at the University of Rochester from 1888, and has published many articles, especially on the glacial geology of New York State.

**FAIRCHILD, James Harris**, American educator: b. Stockbridge, Mass., 25 Nov. 1817; d. 1902. He was president of Oberlin College from 1866-89 after a service of 26 years as tutor, professor of languages, professor of mathematics and professor of moral philosophy and theology. Besides editing the 'Memoirs of Charles G. Finney' (1876) and Finney's 'Systematic Theology' (1878), he was the author of 'Moral Philosophy' (1869); 'Oberlin, the Colony and the College' (1883); 'Elements of Theology, Natural and Revealed'; and 'Woman's Right to the Ballot' (1870).

**FAIRCHILD, Lucius**, American military officer: b. Kent, Ohio, 27 Dec. 1831; d. Madison, Wis., 23 May 1896. At the beginning of the Civil War he enlisted as a private in the Federal army, and in August 1861, was appointed a captain in the regular army and major in the volunteer army. He took part in the battles of Bull Run and Antietam, and led the charge up Seminary Hill at Gettysburg, where he lost his left arm. He was promoted brigadier-general in 1863, but resigned to serve as secretary of state of Wisconsin and was governor 1866-72. In 1886-87 he was commander-in-chief of the Grand Army of the Republic.

**FAIRCLOUGH, Henry Rushton**, American philologist: b. near Barrie, Ontario, Canada, 15 July 1862. He was graduated at Toronto University in 1883 and in 1896 received the degree of D.Ph. at Johns Hopkins. From 1893 to 1902 he was associate professor and professor of classical literature at Leland Stanford University. In the latter year he was made professor of Latin. He also taught Latin in the summer sessions of the University of Wisconsin 1906, Columbia 1908, Chicago 1910, Colorado 1913 and in 1910-11 was professor in the American School of Classical Studies, Rome. He was delegate to the centennial celebration of the University of Berlin in 1910. He is the author of 'The Attitude of the Greek Tragedians Toward Nature' (1896); 'The Andria of Terence' (1901); 'The Connection between Music and Poetry in Early Greek Literature' (1902); 'The Antigone of Sophocles, translated into English' (1903); 'Virgil's Æneid,' with S. L. Brown (1908); 'The Phormio of Terence,' with L. J. Richardson (1908); 'The Trinumus of Plautus' (1909); also 'Monograph on the Text of Terence' (in Transactions of the American Philological Association, 1900). He was editor-in-chief of the 'Students' Series of Latin Classics' and edited Virgil in the 'Loeb Classics.'

**FAIRFAX, Donald McNeill**, American naval officer: b. Virginia, 10 Aug. 1822; d. Hagerstown, Md., 10 Jan. 1894. During the Mexican War he participated in the capture of Mazatlan and Lower California. In 1861 he had personal charge of the transfer of Messrs. Mason and Slidell and their secretaries from the *Trent*, a British mail ship, to the *San Jacinto*. He later took part in the chief naval operations in Charleston harbor; was promoted rear-admiral in 1880 and retired in 1881.

**FAIRFAX, Edward**, English poet: b. Denton, England, about 1580; d. near Otley, England, January 1635. He made a metrical translation 'Godfrey of Boulogne' (1600), of Tasso's 'Jerusalem Delivered,' and dedicated it to Queen Elizabeth; it was highly esteemed by James I, and is still valued; and on this rather than on his own 'Eclogues' the fame of Fairfax as a poet rests. He is also author of a 'Discourse of Witchcraft,' in which he gives an account of the bewitching of his two daughters in 1621.

**FAIRFAX, Thomas, Lord**, English general: b. Denton, Yorkshire, 17 Jan. 1612; d. Nun Appleton, Yorkshire, 12 Nov. 1671. Fairfax warmly espoused the cause of Parliament, and in April 1642 presented to Charles a petition of the people imploring him to be reconciled to his



subjects. The same year he was appointed general of the horse, and in 1644, together with Essex, Waller and Manchester, he held a chief command in the English army sent to co-operate with the Scots. The credit of the battle of Marston Moor has, by some authorities, been divided between Leslie and Cromwell, but, according to others, Fairfax is also entitled to share in it. On the Earl of Essex resigning the command of the parliamentary army in 1645, Fairfax was made commander-in-chief in his room. He insisted on the command of the horse being given to Cromwell. When he took Oxford the first thing he did was to set a guard upon the Bodleian Library, an act for which he deserves the gratitude of posterity. He subsequently, in November 1647, was engaged with Cromwell in putting down the levelers in the army, and in the following year captured Colchester, and caused Sir Charles Lucas and Sir George Lisle to be tried by court-martial and shot. He was one of the king's judges in 1649, and endeavored to prevent his execution. Being ordered to march against the Scottish Presbyterians, he positively declined the command and Cromwell was appointed (26 June 1650) to succeed him. He was appointed one of the lay church commissioners in 1654, and was a member of Cromwell's first Parliament. He assisted Monk against General Lambert, and co-operated in the restoration of Charles II, being one of the committee charged to secure his return.

**FAIRFAX, Thomas**, 6TH BARON OF CAMERON: b. Yorkshire, 1692; d. Greenway Court, Frederick County, Va., 12 Dec. 1782. He was educated at Oxford and was a contributor to Addison's *Spectator*. He came to America and settled on a vast landed estate in Virginia, inherited from his mother, a daughter of Lord Culpeper. This property, the "Northern Neck of Virginia," embraced the region lying between the Potomac and the Rappahannock and included the Shenandoah Valley (about 6,000,000 acres). William Fairfax, his cousin, acted as his agent, whose daughter Anne became married to Lawrence Washington, the elder brother of George Washington. It was at Greenway Court that Baron Fairfax became acquainted with George Washington, and between them a warm friendship sprang up. Fairfax gave Washington employment on survey work on his domain, and did everything he could to advance his interest with the provincial government. During the War of the Revolution, Fairfax, though an ardent loyalist, was permitted to live on his estate in perfect security. The surrender at Yorktown of Cornwallis, and the winning of American independence by the man he had "trained and moulded," was a great mortification to Fairfax, and from this blow he never recovered.

The 12th Lord Fairfax and baron of Cameron, who succeeded in 1900 to the barony, has, like his American predecessors, made no claim to the title.

**FAIRFIELD, Sumner Lincoln**, American author: b. Warwick, Mass., 25 June 1803; d. New Orleans, La., 6 March 1844. He began the publication of the *North American Magazine* in 1833, and continued to edit and publish it for five years. His published volumes include 'Lays of Melpomene' (1824); 'Cities of the Plain'

(1828); 'Poems and Prose Writings' (1840) and 'Select Poems' (1860).

**FAIRFIELD**, Conn., town, port of entry, in Fairfield County, three miles southwest of Bridgeport, on the Long Island Sound, the New York, New Haven and Hartford Railroad. A popular summer resort, it has a beautiful situation and one of the finest beaches on the Sound. The chief manufactures are paper, dog biscuit, aluminum ware, wire goods, ladies' underwear, rubber goods and machinery. It has good public buildings, two libraries and four buildings which date from Revolutionary times. The first settlement was made in 1639 and the town was incorporated the same year. Its town hall, originally built in 1720, contains records dating back to 1648. It was the scene of several Indian and Revolutionary battles, and in 1779 was almost wholly burned by the Hessians and Tories. Pop. 6,134. Consult Child, 'An Old New England Town' (New York 1895); Osgood, 'Centennial Commemoration of the Burning of Fairfield' (ib. 1879).

**FAIRFIELD**, Ill., city, county-seat of Wayne County; 123 miles southeast of Springfield, on the Southern and the Baltimore and Ohio Southwestern railroads. The city is the centre of a fruit-growing belt, especially noted for apples, and has a trade in grain, live stock, tobacco, etc. The manufactures are chiefly flour, lumber and dairy products. It is the site of the Hayward Collegiate Institute. The lighting plant is owned by the city. Pop. 2,479.

**FAIRFIELD**, Iowa, city, county-seat of Jefferson County, 48 miles northwest of Burlington, on the Chicago, R. I. & P. and the C., B. & Q. railroads. The principal manufactures are brooms, tile, agricultural implements, machinery, furniture, carriages, flour and dairy products. The electric-light plant and the water-works are owned by the city. The Parsons College, under the auspices of the Presbyterian Church, was founded here in 1875. The first settlement was made in 1839. Pop. 4,970.

**FAIRHOLT, Frederick William**, English artists and author: b. London, 1814; d. there 3 April 1866. He published 'Coasture in England: a History of Dress to the Close of the 18th Century' (1846); 'The Home of Shakespeare Illustrated and Described' (1847); 'Remarkable and Scientific Characters' (1849); 'Dictionary of Terms in Art' (1854), etc.

**FAIRLIE, John Archibald**, American economist: b. Glasgow, Scotland, 30 Oct. 1872. In 1895 he was graduated at Harvard University and in 1898 received the degree of Ph.D. at Columbia University. He served one year as secretary to the New York State Canal Commission. In 1900 he became junior professor at the University of Michigan, and in 1909 became associate professor, and in 1911 full professor of political science at the University of Illinois. In 1907-08 he served on the Michigan Constitutional Convention and in 1908-09 was special agent of the United States Bureau of Corporations. He was also associate editor of the *National Municipal Review*. He has published 'Municipal Administration' (1901); 'National Administration of the United States' (1905); 'Local Government in Counties, Towns and Villages' (1906); 'Essays in Municipal Administration' (1908); 'Taxation and Reve-

nue System of Illinois' (1910); 'Commission Government in Illinois Cities' (1911); 'The President's Cabinet' (1913); 'Town and County Government in Illinois' (1913); 'Revenue and Financial Administration in Illinois' (1915), and contributions to technical journals on economic, legal and political subjects.

**FAIRMONT**, Minn., city and county-seat of Martin County, 65 miles southwest of Mankato, on the Chicago and Northwestern and the Chicago, Milwaukee and Saint Paul railroads. The city has a Carnegie library, a cigar factory, gas engine works, flouring mills, packing-houses, and brick and tile yards. The water and electric-lighting systems are owned and operated by the municipality. Fairmont was first settled in 1855 and is governed by a mayor and council of one chamber. Pop. 2,958.

**FAIRMONT**, W. Va., county-seat of Marion County, at the head waters of Monongahela River navigable to this point; the Baltimore and Ohio Railroad, the Pennsylvania and the New York Central lines enter the city; 78 miles from Wheeling, 125 miles from Pittsburgh, 300 miles from Baltimore; the centre of one of the largest soft coal operations in the world; abundance of natural gas and oil; commission form of government; permanently improved roads in all directions from the city; model public school system and a State Normal for training of teachers. The principal manufactures are glass, of which there are two of the largest plants in the world, mining machinery, cigars, lumber and iron products. Fairmont has the largest trolley system in West Virginia, reaching from Fairmont to Fairview, Mannington, Clarksburg, Bridgeport and Weston; a healthy climate; fine water supply; beautiful homes and a splendid public spirit. Pop. 18,000.

**FAIRMOUNT**, Ind., town in Grant County, 60 miles northeast of Indianapolis, on the Cleveland, Cincinnati, Chicago and Saint Louis, and the Pittsburgh, Cincinnati, Chicago and Saint Louis railroads. Fairmount Academy and the Wesleyan Theological Institute are located here. It has extensive farming interests and has manufactories of catchup, sauce, bottles and tiles. The waterworks are the property of the municipality. Pop. 2,506.

**FAIRMOUNT COLLEGE**, coeducational institution, situated at Wichita, Kan., under the auspices of the Congregational Church. It was established in 1892, with assistance from the Boston Education Society. A collegiate department was added in 1895, and in 1896 the name of the institution was changed to Fairmount College. It offers courses leading to the B.A. and the corresponding M.A. degrees. The abolishment of the preparatory school was begun in 1912-13, dropping one year at a time. It has a sub-freshman department. In 1916 the college had an attendance of 317. In connection with the college there is a conservatory of music. The library numbers about 32,000 volumes, besides pamphlets.

**FAIRMOUNT PARK**. See PHILADELPHIA.

**FAIRPORT**, N. Y., village of Monroe County, 10 miles east of Rochester, on the New York Central and West Shore railroads. It has extensive farming and fruit-growing interests. It has a manufactory of cans. Pop. 3,112.

**FAIRS AND SHOWS**. A fair is a periodical meeting of merchants in an open market held at a particular place and generally for the transaction of a particular class of business. The origin of fairs is obviously to be traced to the convenience of bringing together at stated times the buyers and sellers of the stock-produce of a district. Fairs are generally held in or near towns, but from their nature are specially adapted to the convenience of country dealers and their customers. Two curious facts are to be noted in the history of fairs. In Europe the numerous festivals of the church afforded the most favorable opportunity for the establishment of these markets. This association is indicated in the German name of a fair, which is identical with that used for the ceremony of the mass. A fair generally brings a concourse of people into the town in which it is held, and gives it something of a holiday appearance. Advantage has frequently been taken of this concourse, either by the persons assembled themselves or by the purveyors of various amusements, to add entertainment to business, and as the business of a particular fair declined it has often, instead of being abandoned, been gradually converted into a periodical opportunity for a saturnalia of amusement. Thus religion, business and diversion have come to be associated in the idea of a fair.

In the Middle Ages fairs were specially privileged and chartered by princes and magistrates, special temporary tribunals were even established for their use. It was then the custom, which in some places still remains, to make a public proclamation of the commencement and duration of the fair. The goods sold at fairs were then of much greater value, as well as variety, than at present, embracing fabrics of all kinds, as well as jewelry. In some parts of the Continent the practice still prevails of purchasing clothing at fairs. Fairs existed in ancient as well as modern times, and are to be found in all parts of the world. In the East they are of great magnitude and importance. At Mecca, during the annual pilgrimages, and at Hardwar in Ajmir, a resort of pilgrims in Hindustan, two of the greatest fairs of the East, we find again the association between commerce and religion. According to Prescott fairs were regularly held in the principal cities of Mexico every fifth day, being the recognized substitute for shops. A fair for the sale of slaves was held at Azcapozales, near the capital. At the principal fair, held at the City of Mexico, the number of visitors reached 40,000 to 50,000. Here the same arrangement prevailed as in the European fairs of the Middle Ages. A court of 12 judges, clothed with absolute authority, maintained perfect order in this great concourse.

The Easter and Michaelmas fairs at Leipzig, the fairs of Frankfort-on-the-Main, of Lyons in France, and Nijnei-Novgorod in Russia, are among the most important fairs of the present day in Europe. The fairs of Great Britain now mostly consist of the weekly market-days of country towns and certain great agricultural meetings, or trysts, as they are called in Scotland, chiefly for the sale of cattle and horses, such as the Falkirk Tryst. There are also, especially in Scotland, a considerable number of the hiring fairs. Among the most celebrated of the

fairs which have been turned into saturnalia are the celebrated Donnybrook fair in the county of Dublin; Bartholomew and Greenwich fairs, London; and Glasgow fair.

In America the State and county fairs have developed into periodical expositions of agriculture, horticulture, stock-raising, manufacturing, domestic science, education, transportation, good roads movement, etc. Most of the States have their State fairs, supported partially by legislative appropriation, and often with permanent buildings. Many county fairs are regularly incorporated companies, composed of farmers and merchants who make a little money out of them. There is now an American Association of Fairs and Expositions, comprising in its membership 52 organizations representing State, county and provincial fairs. The secretary is Charles Downing, of Indianapolis, Ind.

The National Corn Association holds expositions nearly every year and has members in 35 States. The 1913 exposition was at Columbia, S. C., and the 1914 at Dallas, Tex. The slogan of the Association is "The Betterment of Agriculture." It has three classes of exhibits: (1) educational exhibits from agricultural colleges and experiment stations; (2) competitive exhibits between the States; (3) educational exhibits from the Federal Department of Agriculture. Four trophies are awarded: Indiana 10-ear corn trophy, value \$1,000; Colorado oat trophy, value \$1,500; Kellogg single ear trophy, value \$1,000; Farm and Fireside wheat trophy, \$48,000 in cash premiums.

**Business Shows.**—The fair is a country proposition, adapted to the display of agricultural products. To supply a similar demand in the cities for the display largely of manufactures and exploitation of new goods, the business show has developed. It seems to have been a growth from the poultry and horse shows. When the bicycle was in its prime regular bicycle shows were held annually in the large cities of the United States. With the disappearance of the bicycle show the automobile show developed, and this is perhaps the largest attended show now held annually at Madison Square Garden, New York. Business shows are also held for the display of business office conveniences, typewriters, desks, dictographs and the thousand and one appliances now found in counting-rooms and bookkeeping departments. Printing shows are held for the display of the machinery and products of the graphic arts. Each of the more prominent industries at times has its shows, conducted either by associations or by speculators who sell spaces to houses that desire to exhibit. See EXPOSITIONS, INDUSTRIAL.

**FAIRVILLE**, Canada, village of Saint John County, New Brunswick, on the Canadian Pacific Railway. It has pulp and saw mills, box factories, brickyards, breweries, woodenware works, etc., and a hospital for nervous diseases. An electric railway connects the village with the city of Saint John. Pop. 3,500.

**FAIRWEATHER**, Mount, in Alaska, in the Saint Elias range, 35 miles northeast of Cape Fairweather. It is 15,292 feet high and its steep declivities are covered with great glacial sheets.

**FAIRY**, an imaginary being or spirit of diminutive size, supposed generally to assume a

human form, but appearing also in others and represented as both beneficent and malevolent toward mankind. In the latter case diseases of cattle were frequently attributed to their mischievous operations; and cattle that died suddenly without any apparent cause were commonly said to be elf-shot. Among the Irish peasantry they are termed "the good people" by way of placation. In Poole's 'Parnassus' are given the names of the fairy court: "Oberon, the emperor; Mab, the empress; Perriwiggin, Perriwinkle, Puck, Hobgoblin, Tomalin, Tom Thumb, courtiers; Hop Mop, Drop, Pip, Drip, Skip, Tub, Tib, Tick, Pink, Pin, Quick, Gill, Ion, Tit, Wap, Wim, Nit, the maids of honor; Nymphidia, the mother of the maids." Croker, in his 'Fairy Legends and Traditions of the south of Ireland,' describes them as beings "a few inches high, airy and almost transparent in body; so delicate in their form that a dewdrop, when they chance to dance on it, trembles, indeed, but never breaks." They are supposed to live in a distinct domain known as Fairyland, and their character and habits as represented in literature may best be learned from the Irish lore and such works as the 'Märchen of the Grimms'; Spenser's 'Faerie Queene,' and Shakespeare's 'Mid-summer Night's Dream.' The term is used somewhat loosely to include other beings of a similar nature, such as elf, fay, gnome, banshee, goblin, nymph, sprite, sylph, etc. Belief in fairies has existed from earliest times and formed part of the superstition of nearly all peoples. A study of fairy stories is instructive in this connection. Studies of the folklore of many peoples have been made by scholars and have shown valuable results in this field. See FOLK-LORE; MYTHOLOGY; PARACELTUS; also such titles as ELVES, KOBOLD and the like.

**Bibliography.**—Aarne, 'Vergleichende Märchenforschungen' (Helsingfors 1908); Benz, 'Märchen-Dichtung der Romantiker, mit einer Vorgeschichte' (Gotha 1908); Chodsko, 'Fairy Tales of the Slav Peasants and Herdsmen' (London 1896); Delattre, 'English Fairy Poetry' (ib. 1912); Grimm, 'Deutsche Mythologie' (Berlin 1879-98); Friedrichs, 'Grundlage, Entstehung und genaue Einzeldeutung der bekanntesten germanischen Märchen, Mythen, und Sagen' (Leipzig 1909); Hartland, 'The Science of Fairy Tales' (London 1891); Jacobs, 'English Fairy Tales' (3d ed., ib. 1910); id., 'Celtic Fairy Tales' (New York 1910); id., 'Indian Fairy Tales' (London 1892); Keightley, 'Fairy Mythology' (ib. 1850); Ludwig, 'Sibirische Märchen' (Glogau 1890); MacRitchie, 'Testimony of Tradition' (London 1891); Riklin, 'Wunscherfüllung und Symbolik im Märchen' (Vienna 1908); Weber, 'Italienische Märchen' (1900).

**FAIRY BLUEBIRD**, one of the bulbuls (q.v.) of the East Indian family *Pycnonotidae* and genus *Irena*, familiar in Indian gardens, and justly admired. The commonest species is brilliant turquoise, with black wings, tail and under parts, and coral-red legs and beak. They make a rather rough little nest in a bush and lay two or three speckled eggs.

**FAIRY QUEEN**. See FAERIE QUEENE.

**FAIRY RING**, or **CIRCLE**, a ring occasionally observed in pasture, distinguished from surrounding vegetation by being either barer or

more luxuriant and attributed by the peasantry of western Europe to the dancing of the fairies. They are now known to be occasioned by the growth of certain kinds of fungi, which, proceeding outward from a centre, render the soil for a time unfitted for the nourishment of grass, but later fertilize it by their decay.

**FAIRY SHRIMP**, a phyllopodous crustacean (*Chirocephalus diaphanus*), occasionally found in fresh-water ponds in the British Isles. It is about one inch in length and nearly transparent.

**FAIRY-TALES**, stories in which fairies play a part, or which contain other supernatural or magical elements such as mark the folk-tales of 'Puss in Boots'; 'Beauty and the Beast'; 'Hop o' My Thumb'; 'Sleeping Beauty'; and others. Actual fairies seldom appear in traditional fairy-tales, so called. Grimm and his successors showed by the study of comparative mythology that these tales are not restricted to Europe alone, but are to be found, in varying forms, among almost all nations. The survival of popular tales is due to their being unconscious growths, to the strict adherence to form shown by illiterate and savage people in recitals and to the laws of the permanence of culture. There are several theories in regard to the origin of folk-tales. The oldest is the Oriental theory, which traces all back to a common origin in the Vedas. It is true that the germs of most tales are found in Vedas, but proofs of the Indian origin of the stories are lacking; the discovery of tales in Egypt which were written in the early empire are objections to its acceptance, and the idea of diffusion will not account for similar tales found in Australia, New Zealand and America. The Aryan theory, supported by Max Müller, Grimm and others, gives as their origin the explanation of natural phenomena. These nature-myths must not be regarded as originally metaphors; they were primitive man's philosophy of nature in the days when every object was endowed with a personal life. The tales have enough likeness to show that they come from the same source and enough difference to show they were not copied from each other. Müller says "Nursery tales are generally the last things to be adopted by one nation from another." Another theory, supported by Tylor and Lang, traces the origin of folk-lore to a far earlier source than the Aryan—the customs and practices of early man: such as totemism, descent from animals or things, which were at last worshipped; and curious taboos or prohibitions, which can be explained by similar savage customs of the present. But late authorities declare that it is useless to seek any common origin of folk-tales; since the incidents, which are few, and the persons, who are types, are based on ideas that might occur to uncivilized races anywhere.

Our popular fairy-tales, or *contes*, have been, in the main, handed down orally. However, some of their elements or variants at least have come down through ancient Oriental literature. The 'Syntipas,' a Greek version, belongs to the 11th century. Then followed translations into several European languages. The earliest collection of European tales was made by Straparola, who published at Venice in 1550 his

'Notti Piacevola,' which was translated into French and was probably the origin of the 'Contes des Fées.' The best early collection is Basile's the 'Pentamerone,' published at Naples in 1637; reprinted at New York 1912. In 1696 there appeared in the *Recueil*, a magazine published by Moetjens at The Hague, the story 'La Belle au Bois Dormant' (our 'Sleeping Beauty'), by Charles Perrault; and in 1697 appeared seven others: 'Little Red Riding Hood'; 'Bluebeard'; 'Puss in Boots'; 'The Fairy'; 'Cinderella'; 'Riquet of the Tuft'; and 'Hop o' My Thumb.' These were published in 1697 under the title 'Contes du Temps Passé Avec des Moralités,' by P. Darmancour, Perrault's son, for whom he wrote them down from a nurse's stories. Within this century the investigations of Jacob and William Grimm, and their successors in this field, have reduced to written form the tales of nearly all nations. We must include in the comparison of stories the Greek myths; as the *Odyssey* is now conceded to be a mass of popular tales. To these we must add the tales of ancient Egypt; those narrated by Herodotus and other travelers and historians; the beautiful story of 'Cupid and Psyche,' given by Apuleius in his 'Metamorphoses' of the 2d century A.D., which also was taken from a popular myth. See **BEAUTY AND THE BEAST**; **BLUEBEARD**; **ELVES**; **FAIRY**; **FAIRY TALES**; **FOLK-LORE**, etc. Consult bibliography subjoined to article **FAIRY**.

**FAIRY TALES OF HANS CHRISTIAN ANDERSEN.** These 'Fairy Tales' have been read by thousands with delight, and have settled down to a place in the world's memory along with the traditional nursery tales of the race. The Ugly Duckling and The Constant Tin Soldier are remembered in company with Goody Two Shoes or Little Red Riding Hood. The 'Fairy Tales' are among the most original works of the 19th century. Fairy tales are usually stories of legend and tradition; they grow up in the lives of simple peoples without any one's knowing who originally thought of them or told them. They are told and retold by the old people to the children, and then somebody comes and writes them down as, for instance, Mr. Harris wrote down the negro stories of Brer Rabbit and Brer Fox. Of this kind are the famous 'Märchen' of the Brothers Grimm and the 'Contes' of Perrault and many others. These are old stories which have charmed generations put into literary form. Such also are some of the 'Eventyr' or Wonder-stories of Andersen. He was born and brought up at Odense in the island of Funen, a place, which, as he says himself, was in those days a hundred years behind the times. The old women, who made something of a pet of him, used to tell him old stories which revealed to him "a world as rich as that of the Thousand and One Nights," as he said himself afterward, not only in complete stories, but in ways of story-telling. "In the volume which I first published I had like Musæus but in my own manner related old stories which I had heard as a child. The tone in which they still sounded in my ears seemed a very natural one to me." But much of his 'Tales,' and probably the most characteristic element, is something different; it is something of his own. Ander-

sen was a man of a peculiarly childlike nature. He was not very fond of children but he was in simplicity, imagination and impulsiveness not unlike them. In all that he wrote he was an idealist, as children are apt to be, without over-much concern about the actualities of the real world. So when he told stories to children as he often did he spoke naturally in the language and thought which they recognized as their own. "I had written my narrative down upon paper in exactly the language and with the expressions in which I had related them to the little ones." But he generally had in mind a larger audience and his tales were eagerly read by old as well as young. In fact a good many of them are not Fairy Tales at all, but little sketches or imaginations of life. One cannot read them with anything of a critical spirit without imagining that in his best stories he was always telling more or less directly of himself. So many of them are stories of travel—The Ugly Duckling, The Constant Tin Soldier, The Silver Shilling, Thumbelina—and so many of them are full of veiled comment on life, that one is continually reminded of the author who was himself always traveling and always seeing the world. The children, he says, were pleased generally with the story; older people, on the other hand, were interested in the deeper meaning. The 'Tales' were extraordinarily popular; they were known all over Europe and America and translated into a dozen languages. Andersen, himself, made friends everywhere and told his stories everywhere. He was really a poet, a novelist and a dramatist; he wrote much beside his 'Tales' and was, at first at least, inclined to value his deeper work more than his child's stories. But the world has found in his children's stories the peculiar thing it wanted and these slight matters as he originally thought them are the things that have made him immortal. There is nothing especially upon Andersen's 'Tales,' but a good deal about them will be found in his 'Story of My Life.'

EDWARD EVERETT HALE.

**FAIT ACCOMPLI**, fā-āk-kōn'plē, (Fr., an accomplished fact), in diplomatic language, denotes an event that has happened and must be accepted or recognized as definite, however disagreeable.

**FAITH**, the state of mind which treats a certain proposition as true, independently of whether its truth is completely demonstrated. Faith thus partakes of the nature of will. Its most extreme form is found in the famous passage of Tertullian which ends, "Buried, He was raised from the dead; this is certain because it is impossible." While faith rarely goes to such extremes as this, it is of its very nature that even if its object is proved it totally disregards this proof.

Faith is not entirely confined to religious matters. It is inherent in the very nature of knowledge. The general form of all descriptive knowledge is the analysis of a situation. Thus the physicist analyzes his gross physical processes in terms of atoms or electrons, the psychologist reduces everything to atomic mental states, and so on throughout the sciences. Now, one of the most striking features of analysis is that up to the present, at any rate, it has rarely if ever been exhaustive. In the

first place to record all the significant features of a situation is beyond the powers of the human mind. The total condition of a physical experiment includes every single event in the universe in exactly the unique temporal and spatial relations which it bears toward the experiment in question. But furthermore, the ultimate terms of analysis are continually receding. The physicist of yesterday thought in terms of atoms; the physicist of to-day thinks in terms of electrons; and what the terms of the physicist of to-morrow will be we cannot imagine. For these reasons an analysis is almost of necessity incomplete. From the standpoint of a strict yes or no logic, an incomplete analysis is a false analysis. However, the slightest application of a scientific law demands that we should act as if this analysis, which is probably false, and which at the best is not known to be true, were a demonstrated fact. At the very least, it demands that we should trust in the negligible character of the errors of the law, although nothing but our trust in the continuity of nature guarantees that these are negligible. This trust in the continuity of nature conforms in every respect to the definition of faith.

Analysis is not confined to matters of physics and the other natural sciences. A moral situation is susceptible to analysis, and indeed demands analysis before a reasonable course of action can ensue. In determining what to do when our motives lead us in opposite directions, we analyze the many bearings and consequences of our conduct. This analysis which precedes the appeal to conscience is imperfect for exactly the same reasons as those which render our physical analysis imperfect: the complete bearing and consequences of our deeds are never at our disposal. Again it requires an act of faith to treat the results of our incomplete analysis as a basis for conduct and to be confident that just those aspects of the deed which we have overlooked do not give it its dominant moral tone.

Faith is thus the necessary concomitant of analysis both in natural science and in conduct. Analysis makes the scope of faith recede further and further beyond any assignable limit, but the importance of faith remains just what it was in the beginning. To render this faith firm, especially in those matters that concern the moral conduct, has always been the task of religion. By allegory, by the emotional appeal of rite, mythology and creed, religion furnishes a scaffolding for the faith of those who cannot put an independent trust in the continuity of nature and the moral order itself. Just as Descartes and the Occasionalists founded their physics on the honesty of a God guaranteed by faith as well as by demonstration, the exponents of religion have always made some Divine dictum or example their chief moral sanction. Thus Paley based his entire ethics on a system of divinely established rewards and punishments. It is interesting to note that these religious attempts to mediate between faith and analysis leave the need for faith essentially unchanged, as is shown by the emphasis placed on faith by all religious teachers. What religion accomplishes is the transference of the need for faith to objects more easily grasped than abstractions by those of a mystical trend of mind. There are many

non-mystical natures; however, to which it is more natural and simple to have faith directly in the continuities and laws of nature and morals rather than in those things worshiped by the religious, and in these the most vigorous faith is consistent with the entire absence of anything that can be called a religion.

In theistic religions faith naturally acquires as its principal meaning belief in existence of God and in certain dogmas concerning Him. The Jewish faith was primarily a faith in the moral order as personified in Jehovah. The Christian finds the embodiment of his moral order and accordingly the object of his faith in Christ the Redeemer as well as in the Jewish God. The Catholic definition of faith has been paraphrased by Cardinal Newman as "belief in certain doctrines because God has revealed them." This faith is especially directed toward the Church and toward certain official dicta of the Church. The various Protestant sects differ as to their definition of faith, but all emphasize reliance in God. See BELIEF. Consult Harnack, 'History of Dogma' (Boston 1894-99); Inge, 'Faith and its Psychology' (London 1909); James, 'The Will to Believe' (New York 1911).

NORBERT WIENER.

**FAITH, Act of.** See AUTO DA FÉ.

**FAITH, Rule of,** in the early Church, the summary of doctrines taught to catechumens, and to which they were required to give their assent before baptism. From the ancient usage, the phrase has been adopted, not very aptly, in modern theology to denote (1) the true source of our knowledge of Christian truth; and (2) the criterion or standard of Christian doctrine. Protestants find this rule in the Scriptures alone; the Greek and Roman churches, and some Anglicans, find it not only in Scripture, but also in the Church, as the authorized interpreter of Scripture, whose interpretations are embodied in tradition. The Rationalists make reason the final arbiter, and the mind of man the measure of truth. See BIBLE; CREEDS; INFALLIBILITY.

**FAITH HEALER, The.** This play in three acts, by William Vaughn Moody, was first produced in New York, at the Savoy Theatre, on 24 Jan. 1910. Henry Miller and Laura Hope Crews were in the cast. It had been previously presented in Saint Louis, on 15 March 1909. The piece is not as definite in its theme nor as human in its story as 'The Great Divide.' But it was a sincere endeavor on the part of the dramatist to show the struggle that takes place between material and spiritual forces to the weakening of the latter. Moody, being a poet, here tried to write something mystical, and only partly suggested why the Faith Healer, endowed with the power of reviving the sick and raising the dead, suddenly lost that power through a lack of faith in himself. Being a dramatist, he was obliged to justify the human love of the Faith Healer for the heroine, and here he accomplished the one satisfactory stroke in the play—the establishment of the belief that love does not weaken the exercise of the spirit, but rather enhances it.

As an acting play, 'The Faith Healer' is misty, it is unconvincing. This may be due to the fact that it is treated almost realistically;

whereas it is mystic; it takes for granted a theme rarely proven in human experience. The quickening of a paralyzed woman into life, the restoring of a sick baby and then the failure as the Faith Healer's power wanes, are difficult of externalizing. But Moody's art is sincere, and one feels his sincerity above his dramatic effectiveness. As in 'The Great Divide' he falls into the obvious, here contrasting the spiritual exaltation of a devout man with the science of a doctor and the conventional traditions of a minister.

MONTROSE J. MOSES.

**FAITHFUL SHEPHERDESS, The,** a pastoral drama by John Fletcher, published in 1609, and ranking with 'Comus,' which it partly inspired, as one of the finest specimens of this Italian form of poetry extant in English literature.

**FAITHFULL, Emily,** English philanthropist: b. Headley, Surrey, 1835; d. 31 May 1895. Out of pure philanthropy, she founded the *Victoria Press*, 1860, in which women alone were employed as operatives. Queen Victoria encouraged her by appointing her "printer-in-ordinary to the queen." She started the *Victoria Magazine* as an advocate of women's right to lucrative employment, and in the United States lectured in 1872-73, and 1882. She was the author of 'Change Upon Change,' a novel (1868); 'Three Visits to America' (1884).

**FAITHORNE, William,** English engraver: b. London, 1616; d. 1691. He received most of his early training from Sir Robert Peake, and taking the side of the Royalists in the civil struggle of 1640 he was banished to France. In that country he studied under Nateau and after his return to England in 1650 practised as an engraver and also marketed prints. He executed many portraits in crayon after 1680 and engraved several portraits by Lely, Van Dyke and other eminent masters. Consult Fagan, 'A Descriptive Catalogue of the Works of William Faithorne' (London 1888).

**FAIZABAD.** See FYZABAD.

**FAJARDO, fā-hār'dō,** Porto Rico, a seaport on the northeast coast, on the Fajardo River. It has a good harbor and extensive sugar interests. Molasses, sugar and tortoise shell are exported. Pop. 6,086.

**FAKHR-AD-DIN AR-RAZI** fāk'r-ad-dēn ār-rā'zē, Mohammedan theologian: b. Rai, Tabaristan, 1149; d. 1209. He was educated at Merv and Maragha, where among his masters was the celebrated scholar, Al Majd al Jili. He wrote a famous commentary on the Koran, the well-known 'Mafatih-al-haib' and gave much time to all branches of learning. He spent huge sums on experiments in alchemy, then a favorite delusion among the learned. He was also professor at Rai and Ghasni and finally became president of the University of Herat. His commentary was issued at Cairo in eight volumes in 1890.

**FAKIR, fāk'kēr',** or **DERVISH,** the name of a class of religious devotees of the Mohammedan faith, all leading a life of poverty and generally practising mendicancy. The Arabic word *Faqr* signifies "poor" used in a sense of "poor" in the sight of God. The Persian word *Darwesh* is derived from *dar*, i.e., those who

beg from door to door. The observance of strict forms of fasting and acts of piety give them a character of sanctity among the people. They live partly in monasteries, partly alone, and from their number the imams are generally chosen. Throughout Turkey they are freely received, even at the tables of persons of the highest rank. There are, throughout Asia, multitudes of these devotees, monastic and ascetic, not only among the Mohammedans, but also among the followers of Brahma. They trace their ultimate origin to Abu or Ali Bekr, and in Egypt all are under the rule of a supposed direct descendant of the latter. There are 32 religious orders now existing in the Turkish Empire, many of which are scarcely known beyond its limits: but others, such as the Nakshbendies and Mevlevies, are common in Persia and India and Morocco. All these communities are properly stationary, though some of them send out a portion of their members to collect alms. In fact, all religious fakirs are divided into two great classes, the *ba shar* (within the law) or those who govern their conduct according to the principles of Islām; and the *be shar* (without the law), or those who do not live their lives according to the principles of any religious creed. All these orders, except the Nakshbendies, are considered as living in seclusion from the world; but that order is entirely composed of persons who, without quitting the world, bind themselves to a strict observance of certain forms of devotion, and meet once a week to perform them together. Each order has its peculiar statutes, exercises and habits. Since the orders are secret, it is impossible to discover the exact nature of these.

The numerous orders of dervishes are all divided by Europeans into two great classes, the dancing and the howling dervishes. The former are the Mevlevies, and are held in much higher estimation than the other class. They are the wealthiest of all the religious bodies of the Turkish Empire. The dancing of these dervishes is conducted to sounds of music. The movement at first is slow, but as the dervishes become excited it grows in animation, until at last the actors are exhausted, and are obliged to sit down. After a while they rise up again and resume their dancing, which is repeated several times. The whole is concluded by a sermon. The howling dervishes accompany their dancing with loud vociferations of the name of Allah, and violent contortions of the body such as are seen in persons seized with epileptic fits. In former times these dervishes, after working themselves up into a frenzy, used to cut and torture themselves in various ways with apparent delight. The sheiks of all orders have the credit of possessing miraculous powers. The interpretation of dreams, the cure of diseases and the removal of barrenness are the gifts for which the dervishes are most in repute. See **SURISM**.

None of the fakirs are bound by oath to remain in any particular community. Return to the world is also permitted them, but this privilege is rarely used. The head of the convent is called shaikh, and he is appointed by the general of the order. They reside usually in the city which contains the ashes of the founders of their orders, and are subordinate to the Mufti of the capital who has jurisdic-

tion over them. In Turkey the Shaikhu 'l Islam has the right of removing the generals of the various orders. The Mufti has also the right to confirm the shaikhs who may be nominated by any of the generals of the orders. Consult Lane, 'Modern Egyptians' (3d ed., New York 1908); Brown, J. P., 'The Dervishes or Oriental Spiritualism' (London 1868); Hughes, 'Dictionary of Islam' (London 1885).

**FAKUMEN**, Manchuria, town in the south about 40 miles north of Mukden and about 20 miles west of Tie Pass. On 18 March 1905 Fakumen was occupied by the Japanese.

**FALAISE**, fa'lāz', France, town in the department of Calvados, 20 miles south of Caën, on the Ante. It is located on a cliff and has two fine Gothic churches, a college, public library, a hospital and an ancient castle, in which was born William the Conqueror. It has also manufactories of cotton goods, hosiery, leather, dyes and chimes. Nearby at Guibray since the 11th century is held an annual fair in August. Consult Dodd, 'Falaise the Town of the Conqueror' (Boston 1900). Pop. (commune) 6,900.

**FALASHAS**, a Hamitic tribe of Abyssinia, supposed to be descended from Jewish immigrants of the time of Solomon. They claim to have come from Jerusalem and to belong to the tribe of Levi. They exhibit many Semitic traits, although their complexion is a reddish brown like that of the Abyssinians. They practise Israelitic worship although in a somewhat debased form. Contrary to the method of the Jews of other lands they despise commerce and devote their energies more freely to agriculture and practise minor trades. Their synagogues are always surmounted by a red earthen pot. They have a monastic system and education is in the hands of the monks. Estimates of the number of these people vary from 100,000 to 250,000. Consult Flad, 'The Falashas of Abyssinia' (London 1869); Faitlovitch, F., 'Notes d'un voyage chez les Falashas' (Paris 1905).

**FALB**, fälp, Rudolf, Austrian meteorologist: b. Obdach, Styria, 1838; d. 1903. He was educated at Gratz, where he studied theology and entered the priesthood. He soon afterward was converted to Protestantism and in 1869-72 studied mathematics, physics and astronomy at the universities of Prague and Vienna. In 1877-80 he traveled in North and South America, after which he settled in Berlin. His theories of earthquakes were unacceptable to the scientists of this day and have never been seriously considered. He founded the astronomical periodical *Sirius* in 1868. His published works are 'Von den Umwälzungen im Weltall' (3d ed., 1890); 'Das Wetter und der Mond' (2d ed., 1892); 'Kalender der kritischen Tage' (1892-).

**FALCK**, fälk, Niels Nikolaus, German jurist: b. Emmerlef, Schleswig, 1784; d. 1850. He received his education at the University of Kiel and in 1814 was appointed to the chair of law there. He was chosen president of the Schleswig-Holstein Assembly of the States in 1838, but his policy alienated the Liberal party. He published 'Handbuch des schleswig-holsteinischen Privatrechts' (1825-48); 'Sammungen zur nähern Kunde des Vaterlandes'

(1825); 'Juristische Encyclopädie' (5th ed., 1851). He was editor of the *Staatsbürgerliches Magazin* from 1821 to 1831, and continued it as the *Neues Staatsbürgerliches Magazin* from 1833 to 1841.

**FALCKENSTEIN, Eduard Vogel von.** See VOGEL VON FALCKENSTEIN, EDUARD.

**FALCÓN,** fal-kōn, Juan Crisóstomo, Venezuelan statesman: b. on the Peninsula of Paraguana (now the state of Falcón), 1820; d. Martinique, 1870. He was a brilliant soldier in his youth and in 1858 was made leader of the Federalist revolutionary party. He was elected President of Venezuela in 1863, and in that year entered Caracas. The Constitution of 1864 was sanctioned by him, but on the overthrow of his government in 1867, he retired to Europe. Three years later a counter revolution brought him a call to again lead the nation, but he died en route to Martinique.

**FALCÓN,** Venezuela, a maritime state and the most northern, with an extensive coast line on the Caribbean Sea and the Gulf of Venezuela. Its adjoining states are Lara to the south and Zulia to the west. It has a much broken surface, with low mountains inland and sandy plains and swamps along the coast. The climate is healthful except in the swampy districts of the coast. The mountain valleys are very fertile, yielding crops of coffee, cacao, cotton, corn, sugar, tobacco and fruits. Stock raising is on the increase. The state is sparsely settled. Its area is 9,572 square miles, with a population of 139,110. Coro, the capital, is of interest historically and is the chief commercial centre. A railway connects Coro with La Vela de Coro, the state's only seaport, about six miles east of the capital. Coro has a population of 9,452.

**FALCON,** a term broadly given to any of many birds of the family *Falconidae* (q.v.), but more narrowly to the species of the typical sub-family *Falconinae*, whence are derived most of the hawks used in falconry. The falcons proper, for strength, symmetry and powers of flight, are the most perfectly developed of the feathered race. They are distinguished by having the beak hooked at the point, the upper mandible with a notch or tooth on its cutting edge. The wings are long and powerful, the second feather rather the longest; legs short and strong. The largest falcons are the three great Arctic ones represented by the circumpolar jerfalcon (*Hierofalco, gyrfalco*), and its congeners the Greenland, Iceland and Labrador falcons. (See JERFALCON). The type of its race, however, is the noble peregrine (*Falco peregrinus*), to the female of which the term "falcon" was alone given by falconers, and was most highly esteemed for the fierceness, dash and perfection with which she worked. The female is about 17 inches long and 3½ feet in extent of wing; the male is 2 or 3 inches less. The head, neck, a patch under the eye and the whole upper surface are dusky, with gray and brownish shades; the throat and under parts whitish or cream-colored, with dusky bars and arrowheads; legs and feet yellow, bill bluish. It chiefly inhabits wild districts, and preys on grouse, ducks, ptarmigans, pigeons, rabbits, sea-fowl, etc., pouncing upon them from above with terrific swiftness and force, and always showing the greatest courage in its encounters

with rivals or in defense of its nest, which is usually placed on a ledge of some lofty cliff. This species is to be found in nearly all quarters of the globe, for the North American duck-hawk (variety *anatum*) and certain tropical forms are only sub-species.

Other American true falcons are the pigeon-hawk, sparrow-hawk (qq.v.) and some closely allied western and northern forms. Many of the Old World falcons are famous, and are elsewhere individually described, such as the European hobby, kestrel, merlin and lanner; the Asiatic shaheen, saker, luggur, turumti and other species trained by Eastern falconers; the Australasian quail-hawk; and the large African genus Baza, which has the peculiarity of possessing two "teeth" on the edge of the beak. Another interesting genus is *Microhierax*, containing the finch-falcons (q.v.). Falcons attain to a great age. One is said to have been found in France, about 1790, with a collar of gold dated 1610, showing it to have belonged to James I of England.

**FALCON,** a small light cannon in general use in the late Middle Ages. We know from a decree of Henry II of France that it discharged a ball weighing one pound. Some guns of this type are said to have thrown a projectile of six pounds. See ARTILLERY.

**FALCONBRIDGE, Sir Glenholme,** Canadian jurist: b. Drummondville, Ontario, 12 May 1846. He is a graduate of Toronto University, and was called to the bar in 1871. He was appointed a senator of Toronto University in 1881; in 1887 became a judge of Queen's Bench of the Supreme Court of Judicature of Ontario; and in 1900 chief justice. He was knighted in 1908.

**FALCONE,** fäl-kō'nä, Aniello, Italian painter: b. Naples, 1600; d. there, 1665. He studied under de Ribera and through his numerous battle pieces came to be called "L'oracolo delle battaglie." When the Neapolitans rose against Spain, Falcone organized his pupils into a "Death Company," which never gave quarter to a Spaniard. The failure of the insurrection obliged Falcone to retire to Rome. Later he went to France, where he was graciously received by Louis XIV. Under the powerful protection of Colbert he was enabled to return to his native city, where he spent his last years. The Louvre has one of his battle pieces, the Naples Museum two and the Prado, Madrid, two.

**FALCONER,** fa'k'nér, Edmund ("Edmund O'Rourke"), Irish playwright: b. Dublin, 1814; d. 29 Sept. 1879. He joined a provincial company in England, went to London and in 1858 became manager of the Lyceum Theatre. In 1862-66 he was manager of Drury Lane. In 1867-69 he was engaged at the Olympic Theatre, New York. He composed many plays and adapted others. 'Peep o' Day' (1861) was long very popular. Falconer excelled in his delineations of Irish peasant life.

**FALCONER, Hugh,** Scottish botanist and palæontologist: b. Forres, Morayshire, 29 Feb. 1808; d. London, 31 Jan. 1865. He was graduated in arts at Aberdeen University in 1826, and in medicine at Edinburgh in 1829. He was appointed assistant surgeon on the Bengal establishment of the East India Company. Arriving



**FALCONS**

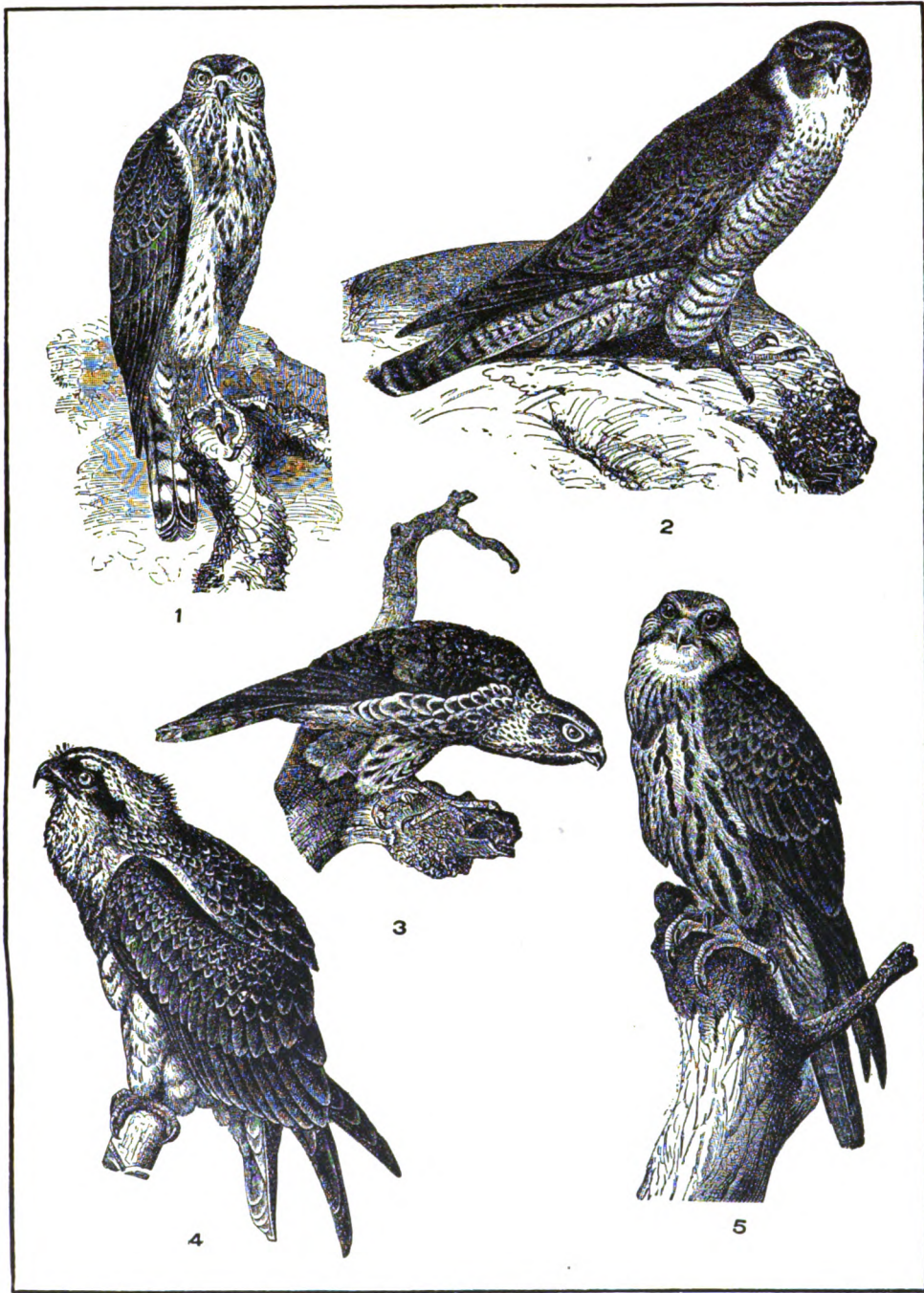

1 Goshawk  
2 Marsh Hawk  
3 Pigeon Hawk or Merlin

4 Fish Hawk  
5 Saker Falcon



in India (1830) he examined and reported on a collection of fossil bones from Ava, and won scientific standing in India. In 1832 he was made superintendent of the botanic garden at Saharanpur. He discovered and was the first to describe the assafœtida plant of commerce; and he discovered the geological character of the Sewalik Hills, and in order to study their ossiferous deposits he compared them with skeletons of extant species. For these researches he received the Wollaston medal of the Geological Society of England. He was appointed (1847) superintendent of the botanic garden at Calcutta and professor of botany at the Calcutta Medical College.

**FALCONER, SIR Robert Alexander**, Canadian educator: b. Charlottetown, Prince Edward Island, 10 Feb. 1867. He was educated at Queen's Royal College School, Trinidad, and at the universities of Edinburgh, Leipzig, Berlin and Marburg. From 1892 to 1907 he was lecturer and professor of New Testament Greek in Pine Hill College, Halifax, N. S., and also served as principal from 1904 to 1907. In the latter year he was chosen president of Toronto University. He received the degrees of Litt.D and LL.D. from the University of Glasgow, from Princeton, U. S. A., Toronto and other Canadian universities. He is Fellow of the Royal Society of Canada and was knighted in 1917. He published 'The Truth of the Apostolic Gospel' (1904); 'The German Tragedy and Its Meaning for Canada' (1915), also articles in professional journals, encyclopædias and dictionaries in Britain and America; articles on education and public questions, etc.

**FALCONER, William**, English poet: b. Edinburgh, 11 Feb. 1732; d. at sea off Mozambique, 1769. Having early shipped before the mast, he became before 1750 second mate of a ship trading to the Levant. The experience of a shipwreck off Cape Colonna, Greece, furnished material for the poem of 'The Shipwreck' (1762), by which he is best known. He was later appointed purser of the frigate *Aurora*, bound for India. The *Aurora* touched at the Cape of Good Hope in December 1769 and was shortly after lost with all hands. Falconer's 'Poetical Works,' with a biography by Gilfillan, appeared in 1854.

**FALCONET, Etienne Maurice**, *ã-tê en mô-rês fâl-cô-nã*, French sculptor: b. Vevay, Switzerland, 1716; d. Paris, 4 Jan. 1791. Catharine II of Russia patronized him, and he was employed by her to execute the colossal statue of Peter the Great, erected at Saint Petersburg.

**FALCONETTO, fal'kô-nêt'tô, Giovanni Maria**, Veronese architect and painter: b. 1458; d. 1534. He received his early instruction from his father, Jacopo Falconetto, an artist of note, and many are of the opinion that he studied also under Melozzo da Forlì. Falconetto executed frescoes in the chapel of San Biagio, the church of San Nazaro, the Duomo and the church of San Pietro, Martire, all in Verona. His 'Augustus and the Sibyl' is in the Veronese Gallery, but is by no means his best work. His most noteworthy architectural work is the Palazzo Giustiniani (1524) at Padua. He also designed many of the Padua city gates.

**FALCONIDÆ**, a family of raptorial birds, comprising the sub-families *Gypætinæ* (lammergeiers), *Polyborinæ* (carrion-hawks and kites), *Accipitrinæ* (hawks), *Buteoninæ* (buzzards), *Aquilinæ* (eagles), and *Falconinæ* (falcons). They are all remarkable for strong and sharply hooked bills, with a distinct cere, usually fleshy; and most of them have sharp and powerful talons, designed to seize, kill and tear to pieces the living prey upon which most of them subsist. In the eagles and falcons these characters are developed in the highest degree. The tarsus is usually more or less feathered, in some cases down to the very toes, which are arranged three in front and one behind and are exceedingly strong and tenacious. There is a projection over the eyebrows except in the ospreys, which gives an appearance to the eyes of being very deeply set in the orbits. These birds range in size from the mighty lammergeier to the falconets, hardly bigger than sparrows. The female is usually decidedly larger than the male and upon her falls the burden of the support of the young. The tribe is represented in all climates, even to the remote north, but is most numerous in the tropics, while some species are nearly cosmopolitan. Many migrate, but few show any tendency toward flocking. The color of the plumage frequently differs much in the young from that of the full-grown birds and as their first plumage is retained for some time, this has caused more species to be enumerated than really exist. Plain tints rule, but white and black are often strikingly displayed and a few species present a considerable variety of colors. Their voice is limited as a rule to screaming cries, but a few utter somewhat melodious notes. The nests of all are rude structures, placed in trees, on rock-cliffs, on the ground or in some hole. The eggs are few in number—one to five as a rule—and are laid much earlier in the year than is the case with birds generally; and they and the young are well cared for and ably defended by the parents. The sport of falconry (q.v.) took its name from employing certain of these birds in the chase.

**FALCONIO, fal-kô'nêô, Diomede**, Roman Catholic prelate: b. Pescocostanzo, Italy, 20 Sept. 1842; d. Rome, 8 Feb. 1917. He entered the Franciscan order 2 Sept. 1860, and upon completing his studies came to the United States as a missionary, reaching Allegany, N. Y., December 1865 and being ordained priest by Bishop Timon of Buffalo, 4 Jan. 1866. In 1868 he was named president of the College and Seminary of Saint Bonaventure, Allegany, N. Y., and on 29 Nov. 1871 was sent by his superiors to Harbor-Grace, Newfoundland, at the request of the bishop of that diocese, who appointed Father Falconio his secretary and chancellor and rector of the cathedral. In 1882 he came back to the United States, where he remained a year. Returning to Italy in 1883, he was elected provincial of the Franciscans in the Abruzzi, and in 1889 he was chosen procurator-general and later visitor-general in various provinces. He was preconized bishop of Lacedonia 11 July 1892, and on the 17th of that month was consecrated at Rome by Cardinal Monaco La Valletta. On 2 Feb. 1893, Monsignor Falconio assumed the charge of his diocese. He was elevated to the United Archiepiscopal See

of Accerenza and Matera in Basilicata, 29 Nov. 1895, but was called thence by Leo XIII, 3 Aug. 1899, and appointed first apostolic delegate to Canada, taking possession at Ottawa, 1 Oct. 1899. On 30 Sept. 1902 he was nominated apostolic delegate to the United States and assumed possession at Washington, D. C., 21 November of the same year. He was elevated to the cardinalate in 1911. A volume of 'Pastoral Letters' appeared in French in 1900.

**FALCONRY, or HAWKING**, the employment of falcons in the chase. This sport is of Oriental origin, and has been practised in the East since before the days of any record—in China at least 2,000 years before Christ; and it was probably followed at that date all over Asia and down into the Nile Valley, for falconers with their hawks are depicted in some of the oldest Egyptian mural paintings. The sport spread over Europe with the Roman domination, but seems not to have been introduced into England until the 9th century. Many laws and social customs regulated this pursuit in Great Britain and many terms and phrases remain in the language as an inheritance from the art and etiquette of this most elegant form of the chase. Thus the square frame on which hawks were carried to the field was named a "cadge," and the servant who bore it a "cadger"; and a "cast" of hawks meant two taken on a chase together. To "man a hawk" was to tame it; and one so thoroughly trained as to be flown with young ones to show them how to work was called a "make hawk." A hawk was said to "mew" when molting, and to "plume" when she pulls off feathers. A female of any species, but especially of the peregrine, is a "falcon"; a male a "tiercel"; one caught wild a "haggard" or "passage hawk"; one reared from the nest an "eyas," and a young one is a "red hawk"; while a falcon's nest is an "eyry." All the actions of a hawk in its work are named. A hawk "stoops" when she descends upon the "quarry" (prey) with closed wings, to kill it by a stroke of the beak; she "binds" when she seizes large prey in the air and clings to it in its fall, or "trusses" when the prey is of small size. A hawk is said to "clutch" when (as do short-winged hawks) she seizes it in her feet; to "carry," when she tries to fly away with the prey; to "check" when she flies at a bird other than the one intended for her; to "foot well" when she kills successfully; to "make her point" when she rises and hovers over some quarry which has escaped to cover, as in thick hedges; to "ring" when she rises spirally in the air; to "take the air" when she tries to get above the fleeing quarry; to "wait on" when she hovers above her master at a certain "pitch" (height), waiting for quarry to be flushed. "Seeling" is closing the eyes with a fine thread (no longer done); "imping," mending broken feathers; "mantling," stretching out the wings or one wing and a leg; and "jarak" means keen, or in good condition for work.

The extensive agricultural changes which occurred in England during the 17th century, causing the enclosure and improvement of waste lands; the growth of towns and industry; the altered temper of the people preceding and during the Protectorate; and most of all the introduction of firearms, followed by the sports of shooting and the consequent preserving of game—all tended toward the decline of falconry,

both in England and on the Continent; and game-keepers and peasants began to shoot as "vermin" the grand and valuable birds upon which their forefathers had doted. Nevertheless the sport is still followed by fanciers who keep alive its traditions.

The hawks used in falconry are all true falcons, and nearly or quite the whole list have at some time or place been regularly trained, except in the United States, although here the best of material exists, in our duck-hawk (the peregrine), pigeon, and sparrow-hawks, southwestern prairie-falcon and others. A few clubs here and there have flown their hawks, but the sport shows little sign of becoming general in North America. It is more frequent in Central and South America. In North Africa and the Orient the sport flourishes as much as formerly; and there eagles are often employed and quarry as large as gazelles and bustards is struck down.

Falconers divide their birds into "long-winged" or "dark-eyed" hawks, and "short-winged" or "yellow-eyed" hawks. The first class contains the true falcons, of which the great jerrfalcon (q.v) was in old times reserved for royalty, the peregrine for an earl and the others for the nobility; hence these were known as "noble," while the goshawk, kestrel, etc., on account of the inferiority of their masters as well as of their own powers, were styled "ignoble."

Hawks are taken for training either as nestlings or when full-grown. They are trained by being hooded, made to wear bands of leather ("jesses") about the legs, to which are attached "varvels" (rings, sometimes carrying bells hung by "bewits"), and a swiveled "leash"; and gradually are accustomed, at first in complete darkness, to being fed and handled, and later to feeding in the light and among spectators, and finally to take first live birds thrown toward it and finally wild quarry. During this process young birds are much at liberty and are then said to be "flying at hawk."

The sport was one in which women as well as men of all classes might indulge, going afield on foot and alone, or in mounted cavalcades, and often during mediæval times with royal pomp. The hawks, hooded, were carried by servants on frames suspended from their shoulders, but each sportsman was likely to hold a favorite bird upon his gauntleted wrist—in Europe on the left wrist, in the Orient on the right. Dogs, especially small greyhounds and pointers, were likely to accompany the falconer and were put to use in flushing birds, starting hares and the like. When the hunting scene was reached the hawks were prepared for flight, and some were freed to "wait on" until quarry was sighted; but others, trained differently, were kept hooded until the falconer himself started or perceived the game, when they were unhooded and sent after it. The sportsmen then followed, watched the chase and recovered prey and hawk as well as they could. Good falcons show a keen interest and great intelligence in their work.

Many books describe both the sport and the falcons in great detail. One of the best of the early works is 'The Booke of Faulconrie or Hawking,' by Turberville (1575). Recent British authors of repute are Brodrick, Salvin, Froeman ('Practical Falconry,' 1869), and J. E.

Harting ('Hints on the Management of Hawks,' 1884). The latest general work is 'Coursing and Falconry,' by Cox and Lascelles, in the Badminton Library, 1892. Consult also the article "An Ancient Sport in the New World," in *Outing* for March 1914.

**FALDSTOOL**, or **FOLDSTOOL**, the name of various pieces of English church furniture, the principal being a portable folding seat, also called faldistory, similar to a campstool used by a bishop when officiating in other than his own cathedral church; and a small desk at which the litany is read, the name dating from a period when folding lecterns were used.

**FALEME**, fā-lā'mē, a tributary of the Senegal River, in West Africa. It rises in Futa-Jallon and flows in a northerly direction for a total distance of about 300 miles.

**FALERII**. See **FALISCI**.

**FALERNIAN WINE**, one of the favorite wines of the Romans, so called from *Falernus Ager* (the Falernian Field), the district in which it was grown, in Campania, Italy. It is described by Horace as, in his time, surpassing all other wines then in repute. In the time of Pliny, however, as he himself informs us, Falernian wine had already, owing to a want of care in its cultivation, begun to decline in quality. See **WINE**.

**FALERNUS AGER**, a district of northern Campania, in ancient Italy, situated north of the river Volturnus. It was famed in classic days for its wine. In modern times the quality of the wine has declined. Consult Nissen, 'Italische Landeskunde' (Vol. II, Berlin 1902).

**FALGUIÈRE**, fā-gyār, **Jean Alexandre Joseph**, zhōn ā-lex-zāndr zhō-zy', French sculptor and figure painter: b. Toulouse, France, 7 Sept. 1831; d. Paris 1900. In sculpture his work is of very notable excellence, and displays originality and vigor and grace. The Luxembourg Gallery in Paris contains his sculptures: 'Christian Martyr' (1868); and 'Victor in the Cock Fight' (1870). 'Progress Abasing Error' is in the Pantheon, 'Poet Holding a Lyre' is in the Place de l'Opera, and among other works are statues of Balzac and Lamartine and one of Lafayette in Washington. His paintings are inferior to his sculptures.

**FALIERI**, Marino, mā-rē'nō fā-lē-ā'rē, Doge of Venice: b. 1278; d. Venice, 17 April 1355. He commanded the troops of the republic at the siege of Zara in Dalmatia. He there gained a brilliant victory over the King of Hungary, and was afterward Ambassador to Genoa and Rome. He was elected Doge of Venice on 11 Sept. 1354, but in the following year dissatisfaction with the light punishment imposed upon a noble who had insulted Falieri's young wife caused him to conspire with the lower orders to overthrow the republic and make himself sovereign of the state. His plot was discovered on the night before it was to have been consummated, and he was beheaded 17 April 1355. The last scenes of his life are depicted in Byron's tragedy of 'Marino Falieri.' Plays have been written on the same subject by Casimir Delavigne and Swinburne. Consult Brown, Horatius, 'Studies in Venetian History' (1907).

**FALISCI**, fā-lis'i, a people of Etruria, said to have been originally a Macedonian colony. They occupied Falerii, one of the 12 Etruscan cities. When they were besieged by the Roman general Camillus, a schoolmaster offered to betray his pupils into the hands of the enemy, that, by such a possession, he might easily oblige the place to surrender. Camillus heard the proposal with indignation, and ordered the man whipped back to the town by the very pupils whom his perfidy would have betrayed. This instance of magnanimity operated upon the people so powerfully that they surrendered to the Romans.

**FALK**, fālk, **Johannes Daniel**, German author and philanthropist: b. Dantzig, Prussia, 28 Oct. 1768; d. 14 Feb. 1826. His capacity for satire was considerable. Among his works are 'A Pocket Book for Friends of Jest and Satire' (1797); 'Men and Heroes' (1796), a satire in verse, and 'Prometheus' (1804), a dramatic poem. He founded at Weimar in 1813 an organization called the "Society of Friends in Need," and established there an institution for the care of orphan and neglected children, which later was taken over by the state, and which still bears his name.

**FALK**, fālk, **Max**, Hungarian politician: b. Pest, 1828; d. 1906. He received his education at Pest and at the Polytechnic Institute, Vienna. In 1848 he was made a member of the Academic Legion, and became editor of the *Wanderer*, in which he advocated a restoration of the Hungarian constitution. Soon afterward he was made private lecturer on Hungarian history and literature to the empress. He wielded a powerful influence as editor of the *Pester Lloyd*, in 1869 became a member of the Hungarian Parliament and allied his fortunes with the party policies of Deák, Eötvös and Andrassy. He published 'Graf Stephan Széchenyi und seine Zeit' (1868, in German and Hungarian); 'Rückerinnerungen an die Königin Elisabeth' (1902); and, with Brachelli, the 12th edition of Galletti's 'Allgemeine Weltkunde' (1860).

**FALK**, Paul Ludwig Adalbert, powl lood'-vīn ā'dāl-bērt fālk, Prussian statesman: b. Metschkau, Silesia, 10 Aug. 1827; d. 7 July 1900. He was appointed Minister of Public Worship and Education in 1872, and in this capacity was mainly instrumental in carrying the so-called May laws (because passed in May 1873-74-75), aimed at the restriction of the Roman Catholic Church in Germany, by limiting the influence of the clergy in the schools, by reorganizing the seminaries for the training of teachers and by defining in a stricter and more comprehensive manner the relations generally of the clergy to the state. (See **KULTURKAMPF**). When, however, Bismarck came to bid for the support of the clerical party, in order to carry out his later internal policy, Falk was compelled to resign. He was latterly president of the Supreme Court at Hamm. His biography by Fischer was published at Hamm in 1900.

**FALKE**, fālke', **Gustav**, German poet: b. Lübeck, 1853. He received his education at the Lübeck Catharineum, engaged in business as a bookseller until 1878, when he began the teaching of music at Hamburg. In 1903, on his 50th birthday, the Hamburg Senate and Commonalty

bestowed on him an annual grant of 3,000 marks. Falke's works include the novels 'Aus dem Durchschnitt' (1892); 'Landen und Stranden' (1895); and 'Der Mann im Nebel' (1899); and the volumes of verse 'Mynheer der Tod' (1892); 'Fanz und Andacht' (1893); 'Neue Fahrt' (1897); 'Mit dem Leben' (1899); 'Hohe Sommertage' (1902); 'Der gestiefelte Kater' (1904); 'Frohe Fracht' (1907); 'Hamburg' (in 'Städte und Landschaften Series,' 1908).

**FALKENHAYN**, falk'ën-hîn, Erich G. A. S. von, German general: b. 11 Sept. 1861. He passed from the War Academy in 1880, spent three years as military instructor in China and served as major in the German brigade of occupation in eastern Asia. He was on the staff of Count Waldersee during the Boxer Rebellion in 1900. In 1912 he became Prussian Minister of War, in which capacity he supported Lieutenant von Forstner of Zabern fame. At the outbreak of the European War General von Moltke was chief of the general staff; he was reported to have fallen ill in October 1914, and Falkenhayn took over his duties. As a matter of fact, von Moltke was superseded on account of disagreement with the Kaiser. He held that the main strategic object should be to break the Allied line at Verdun, while the Kaiser, unable to reach Paris, desired to strike for the Channel coast and attack England. See WAR, EUROPEAN.

**FALKENSTEIN**, falk'ën-stîn, Julius August Ferdinand, German explorer: b. Berlin, 1842. At the University of Berlin he studied medicine and geology and in 1873-76 was a member of an exploring expedition to Loango sent out by the African Society of Germany. On this trip Falkenstein made important discoveries and extensive and valuable collections. He brought home the first gorilla ever taken alive from Africa. About 1881 he founded the German General School Association which later exerted great influence on the educational systems of foreign countries. He wrote 'Die Loango-Küste in 72 Original-Photographien' (1876); 'Die Loango Expedition' (1879); 'Afrikans Westküste: Vom Ogowe bis zum Damara Land' (1885); 'Aerztlicher Reisebegleiter und Hausfreund' (10th ed., 1893).

**FALKIRK**, fal'kërk, Scotland, a parliamentary and municipal burgh of Stirlingshire, 10 miles southeast of Stirling and 25 miles from Edinburgh. Its port, Grangemouth, is three miles distant to the northeast and two canals pass close by the town which is a station on the North British railways. Falkirk includes the suburbs of Grahamston, Bainsford, Camelon and Laurieston. Notable features are the burgh buildings, the town hall, a free library, the Camelon fever hospital and the church. In the churchyard lie several persons once prominent in Scottish history. Falkirk is the principal seat of the iron-casting industry of Scotland, being conveniently situated in regard to supplies of coal and iron ore. Other industries are flour-milling, brewing, distilling, tanning, explosives and chemicals. Trysts, or cattle fairs, were long important but have been replaced by local auction sales, held weekly. Falkirk was an important town as early as the 11th century, being then known as *Eaglais*

*breac* ("church of speckled stone"), later transliterated as Eggesbreth. Near the town in 1298 was fought an important battle between the forces of Edward I and those of William Wallace, in which the Scots were worsted. In 1746 Prince Charles Edward with Highland forces defeated the English under General Hawley. Pop. 33,574.

**FALKIRK**, Battle of, (1) a contest in which Edward I of England gained a victory over Wallace, 22 July 1298. The king's army is said to have contained 7,000 to 8,000 mounted men and 80,000 footmen. Wallace's force amounted to about a third of the English army. His infantry was drawn up in circles, the men in the outer ring kneeling and holding their lances obliquely. The archers occupied the centre of the circles. The overwhelming superiority of the enemy's horse, however, decided the battle. Wallace retired with a small body to Stirling, but the bulk of his army was broken up and destroyed. (See WALLACE, SIR WILLIAM). (2) A battle between the forces of Prince Charles Edward (17 Jan. 1746) and the government troops commanded by General Hawley, whose army was completely routed and compelled to fall back on Edinburgh.

**FALKLAND**, fâk'land, Lucius Cary, Viscount, English statesman and soldier: b. probably at Burford, Oxfordshire, 1610; d. Newbury, 20 Sept. 1643. He was educated at Trinity College, Dublin, and Saint John's College, Oxford, and in 1630 succeeded to the estates of his maternal grandfather. In 1633 he succeeded his father in the peerage and for some years after chiefly resided at his seat of Burford, near Oxford, where he lived in close intercourse with scholars from the neighboring universities. Here it was that Chillingworth composed his famous work against "Popery"; and questions of morals, theology and literature were discussed in a congenial circle with the utmost freedom. In 1639 he took part in the expedition against the Scots. At first he warmly supported the Parliament party, but a strong attachment, however, to establish forms and some doubts of the ultimate objects of the parliamentary leaders, caused him to retract. He became Secretary of State in January 1642, and took the Royalists' side in the civil war, attending the king at the battle of Edgehill and the siege of Gloucester. So dissatisfied was he with both parties that he courted death. At the first battle of Newbury he made for a gap in a hedge from which bullets were raining and so fell. His 'Poems,' edited by A. B. Grosart, were published in London in 1870. Consult Marriott, 'Life and Times of Lucius Cary, Viscount Falkland' (New York 1907).

**FALKLAND**, Scotland, a royal burgh in Fifeshire, 21 miles north of Edinburgh. It contains many ancient houses. The principal industries are brewing and linen-weaving. A noteworthy structure is the ancient royal palace of the Stuarts, which after centuries of neglect has been restored by the Marquis of Bute since 1888. Pop. 2,356. Consult Wood, 'Historical Description of Falkland' (Edinburgh 1888).

**FALKLAND ISLANDS**, two large islands, East Falkland (3,000 square miles) and West Falkland (2,300 square miles), with about 100

islands surrounding them, having a total area of 1,200 square miles, in the South Atlantic Ocean, about 300 miles east of the Strait of Magellan. The scenery bears a striking resemblance to parts of the Western Highlands of Scotland; the soil is light and but scanty crops are obtained. The highest elevation is Mount Adam, 2,297 feet in height. The coast is deeply indented and contains many safe anchorages. There are no roads. Sheep raising is the principal occupation, there being 2,325,000 acres devoted to pasturage. The climate is strictly oceanic, characterized by strong winds, equable temperature and moderate rainfall. The waters round the islands have within recent years become famous as a whale fishing ground, the exports of products being valued in 1914 at £1,300,978 (including South Georgia). Dependencies of the islands are South Georgia, the South Shetlands, South Sandwich Group, South Orkneys and Graham Land. Revenue, 1914, £42,923; expenditure, £36,046. Imports, £233,379; exports, £1,505,464. Vessels cleared (1914), 139, of 263,965 tons. Wireless telegraphy was installed in 1912 and cable communication established in 1915. There is monthly mail communication with Liverpool (28 days' sailing). The government is vested in a governor assisted by an executive council of four and a nominated legislative council. The capital is Port Stanley, on the east coast of East Falkland (pop. 905). Pop. 3,275, mainly Scottish, except for 980 Norse and Swedish. The islands were discovered by Davis in 1592. A settlement was founded by the French in 1764, but their rights were sold to Spain in 1765, who in turn relinquished them in 1771. A British colony which had been established in 1765 was withdrawn in 1774, but Great Britain maintained her claim from the date of her occupancy, and since 1833 has held uninterrupted occupancy of them. On 8 Dec. 1914 a British squadron, under Sir Frederick Sturdee, attacked and defeated a German squadron under Von Spee, sinking the cruisers *Scharnhorst*, *Gneisenau*, *Leipzig* and *Nürnberg*. Von Spee went down with his flagship, the *Scharnhorst*. See WAR, EUROPEAN.

**FALKLAND ISLANDS, Battle of the.** A naval engagement fought on 8 Dec. 1914 between a British squadron under Rear-Admiral Sir Frederick Sturdee (q.v.) and the German Pacific squadron under Admiral von Spee. Of the five German battleships four were sunk, also two transports. The *Dresden* escaped, but was sunk off Juan Fernandez on 14 March 1915. See WAR, EUROPEAN—NAVAL OPERATIONS.

**FALKNER**, fāk'nér, Roland Post, American statistician: b. Bridgeport, Conn., 14 April 1866. He was graduated at the University of Pennsylvania in 1885; studied economics at Berlin, Leipzig and Halle-on-Saale, Germany; was instructor in accounting and statistics in the University of Pennsylvania in 1888-91, and professor of statistics 1891-1900. He served also as statistician of the United States Senate Committee of Finance in 1891; as secretary of the United States delegation to the International Monetary Conference; and as secretary of the conference in 1892. He is author of numerous essays on criminology, sociology, etc.; and was editor of *Annals of the American Academy of*

*Political and Social Science* 1890-1900. From 1904 to 1907 he served as commissioner of education in Porto Rico; from 1908 to 1911 he was statistician in charge of school inquiries for the United States Immigration Commission, and in 1911-12 was assistant director of the census. He has contributed essays on professional topics to economic, statistical and other journals, and has published a translation of August Meitzen's 'History, Theory, and Technique of Statistics' (1893).

**FALKNER**, Thomas, English Jesuit missionary: b. Manchester, 1707; d. 1784. Having studied medicine, he engaged as surgeon on a slave-ship of the South Sea Company, in which he sailed to the coast of Guinea in 1731. He next accompanied a cargo of slaves to Buenos Aires, and while there was taken dangerously ill and was carefully tended by the Jesuits. He was so impressed by the work of the order that he became a Catholic and entered the Jesuit order. He became a priest in 1732 and from that time until 1767 labored as a missionary in Paraguay and the Rio de la Plata region. The expulsion of his order from South America in 1767-68 caused him to return to England where he became a private chaplain. He wrote several works, including 'Botanical, Mineral and Like Observations on the Products of America' (1774); 'A Description of Patagonia and the Adjoining Parts of South America,' of which an uncritical and faulty edition was published by one of Falkner's friends.

**FALKNER ISLAND**, an island in Long Island Sound, nearly opposite Guilford, Conn. Its chief feature is a lighthouse, about 94 feet in height, with a white flash light.

**FALKÖPING**, fəl'chē'ping, Sweden, town in Skaraborg. It is an important railroad junction and is important in Swedish history as the scene of the victory of Margaret of Denmark and Norway over the king of Sweden in 1389. The immediate result was the junction of Sweden with Denmark and Norway. Pop. 4,800.

**FALL**, Albert Bacon, American legislator: b. Frankfort, Ky., 26 Nov. 1861. He was educated in the country schools, but was principally self-taught. From 1879 to 1881 he taught school and read law, and from 1889 to 1904 was a practising lawyer. He worked on a farm, on a cattle ranch and as a miner. He became interested in mines, lumber, lands and railroads, and for many years has been engaged in farming, stock-raising and mining. He served in the legislature of New Mexico and also as associate justice of the Supreme Court of New Mexico, and member of the Constitutional Convention. On 27 March 1912 he was elected by the legislature to the Senate of the United States for the short term expiring 4 March 1913. He was re-elected in June 1912, and his credentials not being signed by the governor he was again elected on 23 Jan. 1913 for the term 1913-19.

**FALL**. See WATERFALL and CATARACTS.

**FALL ARMY WORM**, the caterpillar of a gregarious moth (*Laphygma frugiperda*). See GRASS WORM.

**FALL-FISH**, or **SILVER CHUB**, a cyprinodont fish, or "minnow" (*Semotilus corporalis*) of the eastern United States. It is

very common east of the Alleghanies in clear, swift streams and rocky pools, and has been known to reach 18 inches in length. It is steel blue above, sides and belly silvery, but in the breeding season the fins and lower surface of the males are rosy. The fins are of moderate size and unspotted.

**FALL OF THE HOUSE OF USHER.** The, one of the most famous of the prose tales of Edgar Allan Poe, is to be grouped among the author's stories of morbid psychology. The strange obsession which afflicts the chief character may be described as the fear of fear. The 'Fall of the House of Usher' conforms admirably to Poe's dictum that every word in a short story should tend toward a preconceived effect. The sense of gloom and depression produced in the opening sentence is maintained and if anything deepened to the close. The scene is laid "Out of space—out of time," yet it gives a thrilling impression of reality. The story also illustrates the author's skill in preparing for the end, both by minor details which explain later happenings, and by more elusive methods. Thus, the momentary repulsion which the visitor feels on meeting the physician is connected with the decision regarding the temporary entombment of Madeline, narrated pages later; and the picture painted by Usher inevitably suggests, though in no very tangible way, the vault in which the coffin is placed. The poem, 'The Haunted Palace,' recited by the chief character, is an allegory of a ruined mind. No story of Poe's shows better handling of atmosphere, and it is justly ranked as one of the most admirable of its class. It was first published in *Burton's Gentleman's Magazine* in 1839, and was revised for the collection of Poe's tales issued in 1845.

WILLIAM B. CAIRNS.

**FALL LINE.** The boundary between the Atlantic Coastal Plain and the Piedmont Belt (q.v.) to the west is marked by falls or rapids on most of the streams, due to the fact that the rivers can cut more rapidly on the soft, unconsolidated rocks of the coastal plain than on the harder crystalline rocks of the adjacent region. At an early date the falls marked the head of navigation for coastwise trade. Power is also largely developed along the fall line, which has been responsible for the location of numerous cities, among which are Trenton, Philadelphia, Baltimore, Washington, Richmond, Raleigh, Columbia, Macon and Montgomery.

**FALL OF MAN,** a commonly received doctrine of Christianity, founded upon the historical narrative contained in the third chapter of the book of Genesis, together with the allusions to the same matter in other parts of Scripture. The history of the fall, as given in Genesis, contains the following particulars: God having placed Adam and Eve in the garden of Eden and forbidden them under pain of death to eat of the fruit of the tree of the knowledge of good and evil, Eve, tempted by the serpent, first ate of the fruit herself, and afterward gave of it to her husband, who followed her example. Both were driven out of Eden. Punitive sentences were passed upon each of them, and upon the serpent, which is alluded to by Saint Paul as representing the devil. In the subsequent narrative the consequences of the

fall significantly appear. The first man born of the original pair is a murderer, and his descendants grow in wickedness until a flood is sent to carry them away. As might be expected, this most suggestive narrative has given rise to inexhaustible controversy. The opinions on the fall may be divided into three classes: those which reject the narrative altogether; those which accept it as a mythical or allegorical account of the origin of evil; those which regard it as in the main historical. As a mere matter of literary criticism, the uninterrupted flow of the narrative down to times and events evidently historical, together with the uniformity and sobriety of its style, leave little ground for the supposition that the writer himself supposed he was dealing in allegory. The historical view of the fall, besides the theoretical controversies to which it gives rise as to its account of the origin of evil, encounters difficulties from two sources—the modern sciences of chronology and ethnology. In the meantime these remain difficulties only as these sciences are by no means in a state of sufficient maturity to allow their conclusions to be absolutely applied. It is remarkable that in most mythologies the serpent is worshiped as a beneficent being, though Tylor shows that Aji Dahaka of the Zarathustrians (Zoroastrians), which is a personification of evil, may have an historical connection with the serpent of Eden. With regard to the relation of man's fall to that of Adam, Saint Paul says "by one man's disobedience many were made sinners" (Rom. v, 19), and "as by one man sin entered into the world, and death by sin, and so death passed upon all men for that all have sinned" (ver. 12). It seems impossible to reconcile the constant appeals made in Scripture to the moral nature of man with the notion that that nature is inherently and radically corrupt. It would also appear that the statements of Scripture with regard to the actual moral condition of man, strong as they are, do not absolutely require this mode of accounting for them. Without supposing any radical change of man's moral nature, or even any change of it whatsoever it is only necessary to suppose a change in his relation to God to explain all that is said regarding him. It is supposed that man's moral nature consists of capabilities which are good or bad according as they are directed, and that God himself is the object of all its highest aspirations. The fall being supposed to consist in the alienation of man from God, it is easy to perceive that all these aspirations, being deprived of their proper objects, must apply themselves to improper ones, and become evil in their tendency; hence the sudden rise of pride, selfishness, ambition and all evil passions. In as far also as man's nature is affected by the hereditary transmission of qualities it might become actually vitiated in its tendencies and this, together with the accumulation of evil habits, would produce those climaxes of violence or corruption which have from time to time convulsed or disintegrated society, which have called forth the denunciations of prophets and by their very excesses have produced a reaction, which, however, has left human nature as incompetent to guide itself as ever and ready, after a period of repose, to progress toward another crisis. The fall, according to this view, consists in the moral inadequacy of man's nature when left to itself,



and the actual evils flowing from this inadequacy. It is argued by theologians that in the original sentence pronounced on the transgressors there is contained the promise of a redemption and they maintain that the whole scope of Scripture is directed to the development of this promise and of the scheme of providence associated with it. It is from the New Testament, however, and not from the Old, that the whole doctrine of the fall has been built up. Milton seized on this as the groundwork of his two great poems. (See ADAM; ORIGINAL SIN). Consult Brown, 'Christian Theology in Outline' (New York 1906); Fisher, 'History of Christian Doctrine' (ib. 1896); Clarke, 'Outline of Christian Theology' (ib. 1899); Harnack, 'History of Dogma' (Boston 1899); Mackintosh, 'Christianity and Sin' (New York 1914).

**FALL RIVER**, Mass., city, port of entry, in Bristol County, on Mount Hope Bay at the mouth of the Taunton River; on the New York, New Haven and Hartford Railroad, 49 miles south of Boston. It is connected with New York by the Fall River line of steamers; with Philadelphia by the Merchants and Miners freight line and with New England seaports by passenger and freight lines of steamers. The area of the city is 41 square miles and it is 200 feet above sea-level. It has a good harbor, sufficiently commodious for the largest steamers and excellent water power, as the Fall River, the outlet of Watuppa Lake, has a fall of 129 feet in less than half a mile. The water for city uses comes from Lake Watuppa and the waterworks plant is owned by the municipality. The streets are well laid out; many of the buildings are constructed of the granite which is found in the vicinity. It has excellent public and parish schools, notably the B. M. C. Durfee public high school and the Academy La Ste. Union des Sacrés Cœurs; good circulating libraries, a State armory, over half a hundred churches and chapels, daily and weekly newspapers and electric street railway connections with neighboring cities and towns. Among educational and charitable institutions are Notre Dame College, the free textile school, free civil service school, the Conservatory of Music, Boys' Club, Home for the Aged. Five public parks have been laid out in various parts of the city, and there are beautiful drives to the suburbs.

Fall River is the largest cotton-milling city in the United States. According to the Federal census of 1910 the city had 288 manufacturing establishments, employing \$82,086,000 capital and 37,139 persons; paying \$16,853,000 for wages, and \$35,524,000 for materials; and having a combined output valued at \$64,146,000. The cotton industry, 42 establishments with \$46,000,000 capital, and a combined output valued at \$30,000,000. Next in value of output was the dyeing and finishing of textiles (\$3,000,000). Other important manufactures were foundry and machine-shop products (\$1,000,000); bakery products (\$600,000). There are also manufactories of calico prints, gingham, woolen goods, men's hats, fur goods, pianos, knit goods, yarn, thread, boots and shoes, spools and bobbins, carriages, rope and twine, rubber, soap, etc. Granite quarrying also employs a considerable number of men. The city has a number of national banks, with a

capital of about \$2,500,000 and several savings and co-operative banks. The exchanges at the United States clearing-house during the year ending 30 Sept. 1910 aggregated \$61,031,300.

The United States census of manufactures for 1914 showed within the city limits 315 industrial establishments of factory grade, employing 38,097 persons; 36,834 being wage earners, receiving annually a total of \$16,131,000 in wages. The capital invested aggregated \$89,290,000 and the year's output was valued at \$64,663,000; of this, \$27,502,000 was the value added by manufacture.

The government, under a charter of 1902, is vested in a mayor, chosen annually, a board of aldermen, consisting of 27 members, and subordinate administrative officials. Of these, the school committee of nine members is chosen by popular election. Fall River has an excellent system of sewers, is lighted by gas and electricity. It was settled by grantees of the Plymouth Colony, along Mount Hope Bay upon land obtained by treaty with Massasoit, chief of the Wampanoags. Its inhabitants took a prominent part in the War of King Philip and the territory long remained the hunting ground of the tribe. An Indian reservation is still maintained. The village was included within the limits of Freetown until 1803, when it was incorporated as a separate town under its present name. It was called Troy from 1804 to 1834, when its old name was restored. In 1854 Fall River was chartered as a city and in 1862, on the readjustment of the Massachusetts-Rhode Island boundary, a part of the town of Tiverton, R. I., with a population of 3,590, was annexed. On 2 July 1843, a disastrous fire destroyed several buildings and other property. Consult Earl, 'A Centennial History of Fall River' (New York 1877). Pop. 125,443, including over 50,000 persons of foreign birth and about 400 of negro descent. The population includes also a great number of Canadian French.

**FALL TRANK**, a drink once reputed to cure the effects of falls; a vulnerary made from several aromatic and slightly astringent plants which grow chiefly on the Swiss Alps; hence the name *Vulneraire Suisse*, given to such dried plants cut into fragments. Within the 19th century, in England, a kind of vulnerary known as black beer was often prescribed in country practice for inward bruises.

**FALL WEBWORM**. See WEBWORMS.

**FALLACY**, in logic, an argument used as decisive of a particular issue, which in reality it does not decide. Fallacies are variously classified by different logicians. A fallacy may either exist in the substance or in the form of the argument. If it exists in the substance it does not belong to logic, as commonly understood, to expose it; but logicians differ as to what constitutes the proper distinction between form and substance. J. S. Mill in particular extends the sphere of logic in respect to the treatment of fallacies beyond what has been usually assigned to it.

**FALLEN TIMBERS**, Battle of, 20 Aug. 1794, on the Maumee River, about 15 miles from Toledo, Ohio. The Indians had about 2,000 warriors, with 70 white rangers, French, English and renegade Americans; they were in a line some two miles long at right angles to

the river, behind a forest blown down by a hurricane. Wayne had some 3,000 men; 2,000 regulars and 1,000 mounted volunteers from Kentucky, under Charles Scott, who were thrown to the left to turn the enemy's flank. The Indians began the attack and drove in the advance volunteers; then Wayne sent his regular cavalry to repel them, while his first line of infantry advanced with trailed arms, firing at close range and then charging with the bayonet. Both attacks were entirely successful. Less than 1,000 of the Americans were engaged. They chased the Indians up to the British fort some miles away. Their total loss was 33 killed and 100 wounded, the Indians and British probably losing two or three times as many killed. Eight Wyandot chiefs were slain. This defeat, the greatest ever suffered by the north-western Indians, led in the following year to the treaty of Greenville (q.v.).

**FALLIÈRES**, fā'ly'ér, Clément Armand, French politician and statesman: b. Mézin in the department of Lot-et-Garonne, 6 Nov. 1841. He studied law and was admitted to the bar of Nérac and from 1871-75 was mayor of that city. In 1876, 1877 and 1878 he was elected as a Republican to the Chamber of Deputies, in the latter year being appointed Minister of the Interior, a position which he again occupied in 1882 and 1883. From 1883-85 and again from 1889-90 he was Minister of Public Instruction; in 1887 Minister of the Interior; and in 1887-88 and again from 1890-92 Minister of Justice. In 1890 he was elected senator, a position which he has held ever since. In 1899, when Loubet became President of the Republic, Fallières succeeded him as president of the Senate, a post to which he was elected in 1900 and on 11 Jan. 1906. On 17 Jan. 1906 the National Assembly elected him President of the Republic to succeed Loubet (q.v.).

**FALLING BODIES.** See ACCELERATION; FORCE; FORCE OF GRAVITY; GRAVITATION; GRAVITY; MECHANICS, etc.

**FALLING-SICKNESS.** See EPILEPSY.

**FALLING STARS.** See SHOOTING STARS.

**FALLMERAYER**, Jacob Philipp, yā'kōp fē'lip fäl' mē-rī-ér, German author: b. Tschötsch, Austrian Tyrol, 10 Dec. 1790; d. Munich, 26 April 1861. He fought in the War of Liberation; in 1848 was appointed professor of history at Munich. As a scholar, especially linguist, and as an explorer of the Orient his fame is international and his work authoritative. He published 'Fragments from the Orient' (1845); 'History of the Peninsula of Morea in the Middle Ages' (1830), and other important writings.

**FALLON**, Michael Francis, Canadian Catholic prelate: b. Kingston, Ontario, 1867. He was educated at Ottawa College and at the Gregorian University, Rome, and was ordained to the priesthood in 1894. He became a member of the Oblates on his return to Canada and was appointed professor of English literature at Ottawa University of which he was subsequently vice-rector. In 1898-1901 he was rector of Saint Joseph's Church, Ottawa and from 1901 to 1904 of Holy Angels, Buffalo. From 1904 to 1909 he was provincial of the Oblates of Mary Immaculate and in the latter year was consecrated bishop of London, Ontario.

**FALLOPIAN TUBES**, two ducts or *capals* about five inches long and one-third of an inch in diameter, attached to the upper corners of the uterus. Within they are lined by a mucous membrane continuous with that of the uterine cavity, but differing in having cilia. Outside of the mucous membrane there is a thin layer of muscle-tissue. The outermost layer is from the peritoneum, in large part a fold of the "broad ligament." At the free end the tube flares out into fimbriæ, thus exposing a large surface to catch the ova given off from the surface of the adjacent ovary. Aided by the waving cilia, an ovum passes down this tube to the uterine cavity, there to undergo development or to be extruded with menstrual blood. Spermatozoa can pass up the Fallopian tubes and impregnate an ovum within the lumen. Development then becomes possible, giving rise to tubal pregnancy or ectopic gestation.

**FALLOPIO**, Gabriello, gā-brē-ā'lō fāl-lop'-pē-ō (usually known as FALLOPIUS), Italian anatomist: b. Modena, 1523; d. 9 Oct. 1562. He studied at Ferrara and at Padua, at which last place he is said to have attended the lectures of Vesalius. He became professor at Ferrara, whence, in 1548 he removed to Pisa. He continued there three years and was then made professor of surgery, anatomy and the materia medica at Padua, where he remained till his death. The principal work of Fallopius is his 'Observationes Anatomicae' (1561, 8vo.), which, as well as his other writings, has been several times reprinted. He was the first anatomist who accurately described the vessels and bones of the fœtus and his account of the Fallopian tubes in females has perpetuated his name.

**FALLOUX**, Frédéric Alfred Pierre, frā-dā-rik āl-fred pē-ar fā-loo, French writer: b. Angers, France, 7 May 1811; d. there, 7 Jan. 1886. Legitimist and clerical sympathies influenced his career. He was one of the last survivors of the Liberal Catholic School, was for a time Minister of Education under Napoleon III and passed an act very acceptable to the clericals. He was elected to the Academy in 1857. His efforts to reconcile the Orleanist and Bourbon factions in 1876 recoiled upon himself. His typical writings are 'Madame Swetchine, Her Life and Works' (15th ed., 1884); 'Story of Louis XVI' (6th ed., 1881); and 'Political Speeches and Miscellany' (1882). His memoirs, edited by Veuillot, were issued in 1888.

**FALLOW**, land which, after being tilled, is left for a season or more without being planted or sown. The Roman system of wheat raising was a rotation of fallow and wheat alternately. Under the Romans Britain exported a great quantity of wheat, and for centuries afterward the same system was followed. The method presupposed a moderately fertile soil, and turned out best where clay was present. The object of fallowing is to liberate fertilizing elements from the mold, admitting air and destroying noxious plants and insects. Improvements in agricultural methods and the multiplication of fertilizing material has caused the abandonment of this resort to fallowing which, however, might in some cases be revived with advantage. For summer fallow the land should

be ploughed at the end of May; for winter fallow the land should be ploughed in autumn.

Fallow crops is a term applied to green manuring crops which are of more advantage in moist than in dry climates, where injury is likely to be wrought by autumnal draughts. Bastard fallowing is the Scotch practice of ploughing hay-stubble at the end of summer. It is known in North America as short fallow and is very beneficial.

**FALLOW DEER**, a species (*Cervus dama*) of deer native in southern Europe, northern Africa and eastward of Persia, representing a group of Cervidæ in which the antlers, borne only by the bucks, are round at the base, but are more or less flattened at the extremities. These deer were introduced into northern Europe many centuries ago and now are one of the common park deers of Great Britain and elsewhere, while still remaining wild in their native regions. In size they are small (three feet tall at the withers) and in color vary from fawn to dark brown, the fine soft coat ornamented with large whitish spots, which in some varieties have almost disappeared except in the fawns. The under parts, and lower side of the rather long tail are white. The antlers do not reach their full development until the fifth year. These deer assemble in large herds when free, and feed mainly on herbage, but are fond of certain other foods, especially horse chestnuts, which the bucks knock off the trees with their antlers. They are favorites in parks because of their tameness approaching confidently the persons with whom they are familiar and their flesh is regarded as the best of venison. Two or three fossil species are known, from remains in recent deposits, indicating recent extinction. The most remarkable of these is the animal usually, but erroneously, called "Irish elk" described below.

**Giant Fallow Deer.**—In the peat-bogs of Ireland, and in caves and superficial deposits in Britain and on the Continent, have been found many skeletons of a fallow deer which surpassed even the moose in stature, standing six feet high at the shoulders, and carrying antlers that in some large specimens measure 11 feet from tip to tip. These antlers were broadly palmate, as in the moose, but their "points" curled upward. There is much evidence that these magnificent deer continued to exist after the beginning of the human occupation of Europe, and probably owes its extinction to extermination by prehistoric man. A similar extinct species, Ruff's deer, is found fossil in Germany.

**FALLOWS, Samuel**, American Reformed Episcopal bishop: b. Pendleton, Lancashire, England, 13 Dec. 1835. He came to America in 1848, was graduated at the University of Wisconsin in 1859, was minister in the Methodist Episcopal Church 1859-75 and later of the Reformed Episcopal Church. He served with distinction in the Civil War; was State superintendent of public instruction in Wisconsin 1871-74; regent of the University of Wisconsin in 1866-74, and president of Wesleyan University in 1874-75. He became rector of Saint Paul's Reformed Episcopal Church in Chicago in 1875 and bishop in 1876. He was chairman of the Educational Congress of the World's Colum-

bian Exposition 1893; president of the board of managers of the Illinois State Reformatory 1891-1912; chaplain-in-chief of the Grand Army of the Republic 1907-08, and its national patriotic instructor 1908-09; commander Military Order of the Loyal Legion of the United States for Illinois 1907; department commander for Illinois of the Grand Army of the Republic 1914-15; president of the State Illinois Commission for the International Celebration of the 50th Anniversary of Negro Freedom and Conduct of the Lincoln Jubilee 1913-16. He is the author of numerous works, including 'Handbook of Abbreviations and Contractions'; 'Life of Samuel Adams'; 'Students' Biblical Dictionary'; 'Past Noon'; 'Splendid Deeds'; 'Supplemental Dictionary of the English Language'; 'Popular and Critical Biblical Encyclopedia' (1901); 'Health and Happiness' (1908).

**FALLS CITY, Neb.**, city, county-seat of Richardson County, on the Chicago, Burlington and Quincy and the Missouri Pacific railroads, about 85 miles southeast of Lincoln. Its chief manufactures are flour, canned goods, cigars, foundry products, furniture, cement, stock powder, cider, vinegar and beer. The trade is chiefly in wheat, corn, cattle and manufactured articles. It has railroad shops, grain elevators and a poultry-packing plant. The electric-light and waterworks plants are owned by the city. It has a good public library. Pop. 3,500.

**FALMOUTH**, fal'muth, England, municipal borough and seaport in the county of Cornwall, at the mouth of the Fal River, 11 miles from Truro, and is an important point of call for steamer lines. It has a good harbor, the docks extending to 100 acres, and a fine and spacious roadstead. There are two castles on the coast, one of which, Pendennis, commands the entrance of the harbor on the west, and the other, on the opposite side, is Saint Mawes Castle. Its trade consists chiefly in engineering, shipbuilding and ropemaking. Great improvements have been made on the sea front, and Falmouth has risen into favor, owing to its beautiful surroundings and mild and equable climate, as a wintering resort. The borough forms part of the parliamentary borough of Penryn and Falmouth. Pop. 13,132.

**FALMOUTH, Ky.**, city and county-seat of Pendleton County, 59 miles northeast of Lexington, on the Licking River and on the Louisville and Nashville Railroad. It is in an agricultural and dairying region, with a trade in tobacco, grain, clover seed and live stock, and has flour, lumber and woolen mills, tobacco warehouses, a creamery, distillery and cannery. It contains two banks with resources of \$600,000 and the value of the taxable property is placed at \$750,000. The waterworks and electric-light plant are owned by the municipality. The government is vested in a mayor and six councilmen. Pop. 1,600.

**FALMOUTH, Mass.**, town in Barnstable County, on Buzzard's Bay, Vineyard Sound and on the New York, New Haven and Hartford Railroad, at the extreme west end of Cape Cod, 50 miles northwest of Boston. It is the centre of an agricultural and cranberry region. It is best known as containing the Wood's Hole (q.v.) Station of the United States Fish Com-

mission. It has a public library and is a popular summer resort. Falmouth was settled in 1636 and incorporated in 1686. The town owns the waterworks. Pop. 3,144.

**FALSE ACACIA.** See LOCUST TREE.

**FALSE BAY**, an inlet on the coast of Cape Colony, South Africa, circular in form, about 24 miles long, and so well protected from storms as to render it a good shelter harbor. Simonstown, a British naval base, is in the northwest angle.

**FALSE CADENCE**, a musical term. When the last chord of a phrase is other than the tonic chord and is preceded by that of the dominant, the cadence is said to be interrupted, false or deceptive. See CADENCE.

**FALSE CHINCH-BUG.** See WHEAT INSECT PESTS.

**FALSE DECRETALS.** See DECRETALS, FALSE OR PSEUDO-ISIDORIAN.

**FALSE DEMETRIUS**, The. See DEMETRIUS.

**FALSE IMPRISONMENT**, the unlawful detention of a person, whether in a common prison or a private house, or even by forcibly detaining one in the streets or highways. The law punishes false imprisonment as a crime, besides giving reparation to the party injured through an action in tort.

**FALSE INDIGO**, a common name for some American species of the genus *Amorpha* of the pea family. The most widely known plant called by this name is *A. fruticosa*, a shrub growing from 5 to 20 feet in height along streams in Ohio, Minnesota and Manitoba, south to Florida, Colorado and Mexico. When found in the Middle States it is an escape from cultivation, its spike of purple flowers making an exceedingly ornamental shrub.

**FALSE PERSONATION**, for the purpose of obtaining property of others, was formerly a misdemeanor punishable by a fine or imprisonment, but is now made penal by special statute. The penalties for personation are frequently heavy. Thus to personate the owner of any share, stock or annuity, etc., is felony, and liable to a term of imprisonment. The false personation of voters at an election is a misdemeanor punishable with imprisonment.

**FALSE POINT**, a cape (with lighthouse) and harbor of Bengal, 43 miles east of Cuttack. The roadway in which ships anchor is somewhat exposed and loading and unloading can only be carried on in comparatively fair weather. Large rice shipments are made. The name was given because frequently this projection was mistaken for Point Palmyras.

**FALSE POSITION**, Rule of. An ancient method of reckoning indirectly, now superseded by the method of equations. In the ancient method a number for the unknown quantity was assumed; next a trial was made to see if the assumed number filled the conditions; it was then corrected by the method of simple propor-

tion. For example, what number is that whose third exceeds its quarter by 5? Assuming 72 to be the number, we get  $24 > 18 = 6$ , which is too great. Now, by means of proportion we have  $6:5::72:60$ . Hence 60 is the number whose third (20) exceeds its quarter (15) by 5.

**FALSE PRETENSES**, for the purpose of obtaining property, is a misdemeanor at common law, and punishable by fine or imprisonment. Some kinds of it are now punishable by imprisonment not exceeding five years, the statutes, however, varying in different States.

**FALSE SCORPION**, or **BOOK SCORPION**, a diminutive spider-like creature of the order *Pseudoscorpionida* (see ARACHNIDA), allied to the "harvestmen" and "false spiders." They occur in all the warmer parts of the world, under bark, stones and rubbish, or hidden in deep moss; and one typical species, the "book scorpion" (*Chelifer cancelloides*), infests museums, old libraries and dusty corners generally. Unlike the spiders these have no constricted "waist" separating the abdomen from the foreparts; and like the true scorpions the pedipalps are developed into relatively enormous chelate arms. The book scorpion thus resembles a minute crab. They are slow in their motions, feeling their way along with their pincers; and several blind species inhabit caverns. They have spinning glands, situated in the cephalothorax, but use the silk only for making small protective cells or cases into which they retreat when laying eggs (afterward carried about by the female), or molting, or during hibernation.

**FALSE SPIDER.** See SCORPION SPIDER.

**FALSE SWEARING.** See PERJURY.

**FALSE WEIGHTS AND MEASURES.** See WEIGHTS AND MEASURES.

**FALSEN**, fal'sen, Christian Magnus, Norwegian historian and statesman: b. Oslo, near Christiania, 1782; d. 1830. He entered the legal profession and in 1808 was appointed circuit judge at Follo. He became interested in politics about 1814 and helped draw up a constitution for Norway after the separation of the latter from Denmark. He divided honors with Sverdrup in parliamentary leadership, became attorney-general in 1822, but lost much of his support among the liberal element through his administration of this office. He was made bailiff for Bergen in 1825 and two years later became chief of the Supreme Court. He wrote 'Norges Historie' (1824). Consult the lives by Daa (Christiania 1860) and Vullum (ib., 1881).

**FALSETTO** (Ital.), in singing, a term applied to the notes above the natural compass of the voice. It is also called a head or throat voice, in contradistinction to the chest voice, which is the natural one. The falsetto voice is produced by tightening the ligaments of the glottis. Its thin, constrained effect is most noticeable in men with deep-set voices the register of which it frequently extends more than an octave above the pure chest voice.





